

Model ZW218

Slow Closed Check Valve
Globe and Angle Pattern Bodies

1 1/4", 1 1/2", 2", 2-1/2", 3", 4", 6", 8", 10", 12", 14" & 16"

*Contains a weighted average lead content less than 0.25% for wetted surfaces

LEAD-FREE*



- Installation
- Troubleshooting
- Maintenance Instructions

Installation / Start-up

NOTE: Flushing of all pipe lines is to be performed to remove all debris prior to installing valve.

CAUTION: The recommended installation orientation for ACVs is horizontal, with the valve cover up. 6" and larger valves should only be installed horizontally, with the valve cover up, due to the difficulty of properly bleeding air out of the cover on valves installed in the vertical orientation. In addition, the horizontal positioning of the larger valves avoids premature wear due to the mass of plunger assemblies as well as allows for greater accessibility during annual inspections, and maintenance.

1. For making adjustments and servicing allow for adequate space around the valve before installing valve.
2. When installing a ZW218, gate valves installed on both inlet and outlet are recommended for maintenance allowing for isolation of valve.
3. Position the valve in line matching the direction of flow as indicated on the valve model tag with the proper direction of flow in the system. Once attached to line, double check all fasteners/bolts in the pilot system and on main valve are tight and there is no damage prior to pressurizing system.

NOTE: Pressure in some applications can be very high so be thorough in checking and inspecting for proper installation and makeup.

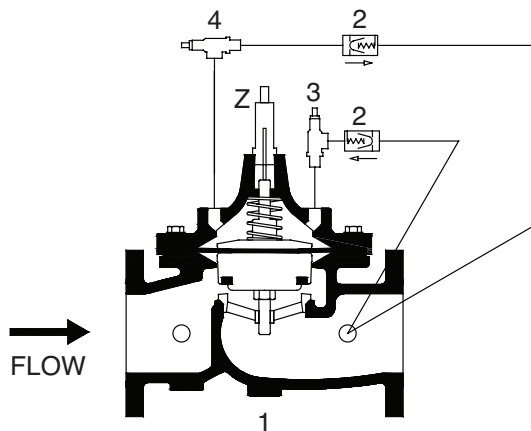

ZW218 SCHEMATIC STANDARD COMPONENTS

1. Main Valve
2. Check Valve
3. Closing Speed Control
4. Opening Speed Control

⚠ **WARNING:** Cancer and Reproductive Harm - www.P65Warnings.ca.gov
⚠ **ADVERTENCIA:** Cáncer y daño reproductivo - www.P65Warnings.ca.gov
⚠ **AVERTISSEMENT:** Cancer et néfastes sur la reproduction - www.P65Warnings.ca.gov

START-UP

CAUTION: To prevent personnel injury and damage to equipment check that downstream venting is adequate prior to start-up and test procedures. **All adjustments under pressure should be made slowly while under flowing conditions.** If the main valve closes too fast it may cause surging in upstream piping.

1. Slowly open the upstream supply shutoff valve only enough to fill main valve assembly and pilot system. Prior to pressurizing the valve assembly it is also recommended that a ZPI valve position indicator be installed to aid in verifying proper valve movement.

2. As the valve is filling with water, it is necessary to bleed the main valve and pilot system of air. To vent air, partially open or loosen the highest plugs or fittings in the system. **Use caution when loosening plugs.** The ZPI valve position indicator is a great location, as it has a test cock at the top to vent air pressure. It may be necessary to bleed system more than once. After removal of air in the system tighten all loose fittings.

NOTE: If valve is installed vertically, it will be necessary to loosen some upper cover bolts until you have vented all the air from the cover chamber.

3. Back out the adjusting screw or handle a minimum of 3 turns from closed position, on both speed controls.

4. At this point with the upstream supply shutoff valve partially open, slowly open the downstream system shut off valve. Flow will begin to occur and pressure should build up in valve and eventually stabilize.

5. Next it is advisable to flow water through the valve to ensure all air has escaped from system. High flow may be needed to flush all air.

6. After valve has been flushed the main valve opening and closing speed controls (3 or 4) can be adjusted as needed. If downstream pressure changes rapidly upon valve opening because of pump start-up or similar scenario, adjust the opening speed control clockwise until operation is acceptable. The valve will open slower. Adjust the closing speed control counterclockwise if check valve does not close quickly enough when there is a back flow condition. The valve will close quicker. Tighten the locknuts on the speed controls.

Troubleshooting

The following troubleshooting information deals strictly with the ZW218 valve and pilot systems. It is recommended to verify that the pilot system is properly functioning before troubleshooting the main valve.

PILOT SYSTEM FUNCTION CHECK

1. If pressure surges occur, adjust speed controls until pressure is stable.
2. If valve does not open or close verify water flows through the pilot tubes. Clear obstruction if found.
3. After checking for flow through pilot tubes if the valve still does not open or close, open the main valve and check for obstructions by the seat or on the valve stem.

DIAGNOSIS CHECKS

CAUTION: Do not service valve while under pressure. When performing diagnosis checks on the ZW218 when the valve is fully open, high flow rates and high downstream pressures can occur. In order to prevent harm to personnel, equipment, and downstream piping be sure a downstream valve is closed before performing checks.

DIAPHRAGM CHECK

1. Slowly close upstream shut off valve and relieve all pressure downstream.
2. With all pressure relieved in the main valve, disconnect the tube connected to the outlet port of the main valve. Install pipe plugs in outlet port so water can not flow out of valve. Remove plug on cover and leave off.
3. Then open upstream shut off valve partially, allowing water to flow through the valve. While flowing water monitor the opening on the cover. Water will flow from the cover as the plunger assembly rises, if water continues to flow once main valve is fully open then there is most likely damage to the diaphragm or fluid is leaking past the diaphragm assembly due to loose assembly. It is recommended that the valve cover be removed to investigate the leakage (To remove cover see "Maintenance" section for procedures). If water stops flowing out of cover then the diaphragm is good and you may proceed to the diaphragm movement check.

DIAPHRAGM MOVEMENT CHECK

1. The diaphragm movement check can be determined during the diaphragm check by removing the top center plug.

1. TABLE VALVE STEM TRAVEL

VALVE SIZE (in)	VALVE SIZE (mm)	STEM TRAVEL (in)	STEM TRAVEL (mm)
1-1/4" - 1-1/2"	38	0.4	10.2
2"	50	0.7	18.0
2-1/2"	65	0.8	21.3
3"	80	0.9	23.4
4"	100	1.1	28.8
6"	150	1.7	43.4
8"	200	2.4	59.7
10"	250	2.8	71.1
12"	300	3.4	86.4
14"	350	3.8	96.5
16"	400	4.3	109.2

2. For smaller valves (6" and below) diaphragm checks can be performed by hand with the use of a valve stem tool. The valve stem tool can be made using Table 2 to create a "T" bar handle with the appropriate threads on the opposite end of the "T" handle.

TABLE 2. VALVE STEM THREAD SIZE

VALVE SIZE (in)	THREAD SIZE UNF INTERNAL
1-1/4" - 1-1/2"	10-32
2"	10 - 32
2-1/2"	10 - 32
3"	1/4 - 20
4"	1/4 - 20
6"	1/4 - 20
8"	3/8 - 16
10"	3/8-16
12"	3/8-16
14"	3/8-16
16"	3/8-16

3. To perform the diaphragm check using the valve stem tool, first remove all pressure in the system and vent the cover. Then remove the center plug on the cover and insert tool into the top of the stem threads. Once the tool is inserted, the valve can be lifted up and the valve movement can be measured by creating marks on the tool in the opened and closed positions. The distance between marks is the valve stem travel. Replace or repair any parts as necessary.

CAUTION: water will squirt from center hole or can be vented from extra plug on cover when lifting.

Maintenance Instructions

PREVENTATIVE MAINTENANCE

The Zurn Wilkins ZW200 models require minimal maintenance. However, it is highly recommended to schedule annual inspections and to have a repair kit on hand before work begins. Valves used often may be inspected on an annual basis, but at least every five years. Valves that rarely open, should be inspected every six months to one year for water deposits, debris, or corrosion.

DISASSEMBLY

Warning: Because of the ability to perform inspections and maintenance without removal from the system, it is very important that all shut off valves be closed and all pressure relieved in the valve before beginning disassembly. Failure to do so can result in personnel injury or equipment damage.

1. Verify that all pressure sources are closed up and downstream of valve.
2. Remove pressure in pilot system by loosening the tube fittings to the valve body and cover. When all pressure has been vented, continue to disassemble the pilot control valve and cover tubing. **NOTE:** Taking a picture before tear down can help with re-assembly of pilot system.
3. Next remove the cover by loosening and removing the cover bolts. If the cover does not come off easily it may be necessary to loosen the cover using a brass chisel and rubber mallet. Apply the chisel under the cover pointing upward away from valve body and tap bottom of cover with the chisel and mallet to loosen the cover. Once the cover is loose, pull cover straight up to avoid damaging the stem and stem bearing in the cover. On larger valves 8" and up, eye bolts and a hoist are recommended due to the weight of these larger covers.
4. With the cover removed the diaphragm assembly can be removed. To avoid damaging the seat bushing, grab the stem and lift straight up. For larger valves 8" and up it is recommended that an eye bolt with the proper stem threads be used with a hoist to lift the assembly out of the valve (see Table 4 for appropriate stem threads).
5. Next it is recommended that the diaphragm assembly be placed in a vise with the bottom hex secured. Once secured remove the spring and stem nut.
6. After inspecting the stem and removing the nut the diaphragm assembly can be dismantled. If the valve has not been serviced in awhile it is possible that the assembly will require the use of a rubber mallet or pry bars to dismantle the assembly. If this is the case gently tap or pry the components until the components are free to move. When disassembling be sure to clean, inspect, and save all components. Replace any damaged components as necessary.
7. The last component to inspect is the seat which is in the body of the main valve. During inspection of the seat, clean and polish as necessary with fine grit wet/dry sandpaper (400 grit or higher). Typically, if after cleaning there is no visual damage or excessive wear the seat should not require removal. If damage is present or the seat is excessively worn the seat should be replaced.
8. To remove the seat, on valves 6" and smaller the seat is threaded into the body and will require a seat removal tool. Care should be taken when removing the seat to avoid damaging. On 8" and larger valves, the seat is held in place with flat head hex screws. For larger valves a seat puller may be required to remove the seat from the body. A seat tool may be made by grinding three notches for the spokes in the end of a pipe. Turn with a pipe wrench.

INSPECTION OF COMPONENTS

Cleaning of components is required for proper inspection. Lime deposits are common in systems that use water. To remove deposits, fine grit wet/dry sandpaper (400 grit or higher) can be used. If deposits cannot be removed, off the shelf lime deposit remover can be used. Prepare a solution following the lime deposit remover instructions and soak components (excluding rubber components) until lime deposits are removed.

CAUTION: When handling chemicals (acids) be sure to use proper safety equipment (gloves and eye protection) and practices. After soaking components, be sure to thoroughly rinse all components before handling and re-assembling valve.

Once all valve components have been cleaned, inspect each component looking for damage, abnormal wear & corrosion, and replace all components that look questionable. Replace all rubber components including the diaphragm, o-rings and disc each time the valve is serviced or inspected (rubber components are standard in ZW200 repair kits).

REASSEMBLY

1. First reinstall seat into body. Be sure to use lube around seat o-ring before tightening. Tighten seat according to torque values in Table 5 using seat tool.
2. Next place valve stem in a vise clamping on the hex portion of the stem. Then assemble the diaphragm assembly as shown in Figure. When assembling be sure that the diaphragm is centered on the raised step of the disc retainer. It is also recommended to apply lube to stem threads and o-rings before tightening. Then tighten the stem nut according to Table 5 for torque values.
3. Lower diaphragm assembly carefully into the seat bushing. Be careful not to damage the seat or stem while installing assembly. Rotate the assembly as needed until the bolt holes on the diaphragm line up with the body bolt holes.
4. Place lower spring disc on the diaphragm disc and place spring on top of the assembly. Then install cover, aligning the bolt holes and insuring that the cover is not pinching the diaphragm between the bolt holes. Position cover so plug holes and pilot connection are in original position.
5. Install cover bolts and tighten in a star pattern to the torque values in Table 5.
6. Before installing center cover plug manually check that assembly has full operating travel before installing the pilot assembly (refer to "Diaphragm Movement" in the diagnosis checks section).
7. Once full operation range of the main valve is verified, begin reinstalling pilot system.
8. After installing pilot system double check that all plugs, bolts, and fittings are sealed and tight before applying pressure.
9. Slowly open upstream supply isolation valve to pressurize the system and check for any leaks.
10. Stop leaks as needed and proceed to "Start-Up" and "Diagnosis Check" sections for returning valve to proper system operations.

TABLE 5. VALVE TORQUE SETTINGS

VALVE SIZE (in)	COVER (ft-lbs)	DIAPHRAGM ASSEMBLY (ft-lbs)	THREADED SEAT (ft-lbs)	SEAT BOLTS (ft-lbs)
1-1/4"	3.5	7.5	11	N/A
1-1/2"	3.5	7.5	11	N/A
2"	15	20-25	30	N/A
2-1/2"	25	25-35	60	N/A
3"	25	35-45	70	N/A
4"	55	40-50	85	N/A
6"	110	50-60	95	N/A
8"	120	60-70	N/A	7.4
10"	184	70-75	N/A	7.4
12"	200	110-115	N/A	7.4
14"	275	170-175	N/A	7.4
16"	360	230-240	N/A	7.4

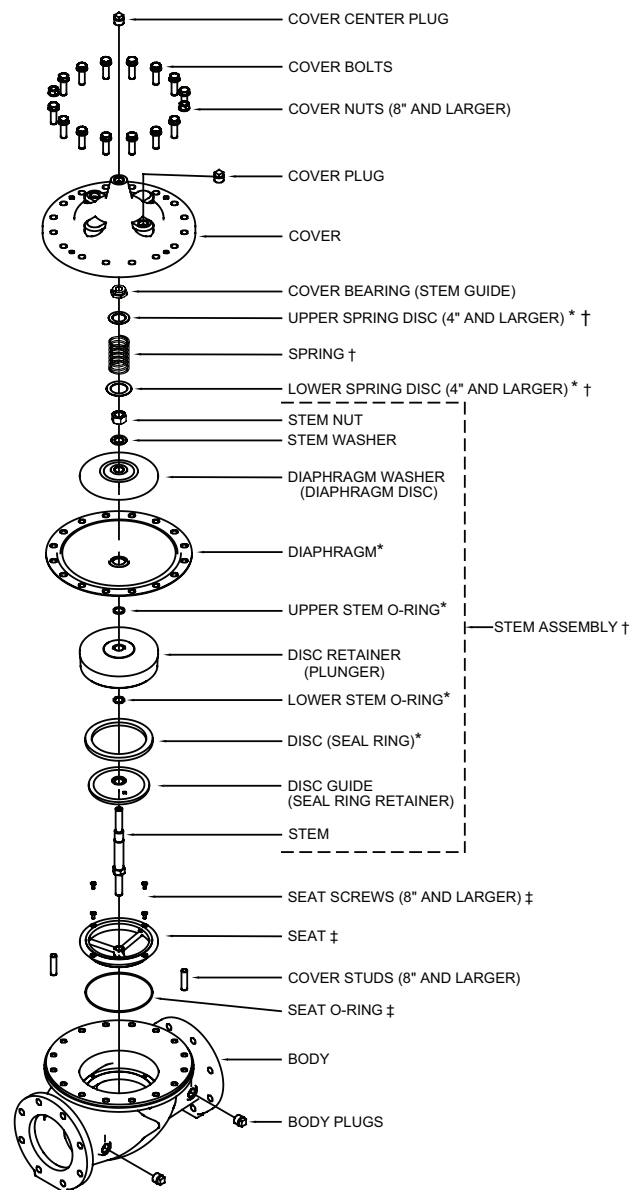

* RUBBER REPAIR KIT ITEMS

† COMPLETE REPAIR KIT ITEMS

‡ SEAT REPAIR KIT