

Model ZW205

LEAD-FREE*



Pressure Relief / Pressure Sustaining Valve
Globe and Angle Pattern Bodies

1-1/4", 1-1/2", 2", 2-1/2", 3", 4", 6", 8", 10", 12", 14" & 16"

*Contains a weighted average lead content less than 0.25% for wetted surfaces

□ Installation □ Troubleshooting □ Maintenance Instructions

Installation / Start-up

NOTE: Flushing of all pipe lines is to be performed to remove all debris prior to installing valve.

CAUTION: The recommended installation orientation for ACVs is horizontal, with the valve cover up. 6" and larger valves should only be installed horizontally, with the valve cover up, due to the difficulty of properly bleeding air out of the cover on valves installed in the vertical orientation. In addition, the horizontal positioning of the larger valves avoids premature wear due to the mass of plunger assemblies as well as allows for greater accessibility during annual inspections, and maintenance.

NOTE: When installing a valve, make sure there is adequate space around the valve for adjustments and servicing.

1. When installing a ZW205, gate valves are recommended on both the inlet and outlet of the valve for maintenance, allowing for isolation of valve.
2. Position the ZW205 in line matching the direction of flow as indicated on the valve model tag with the proper direction of flow in the system. Once attached in-line, double check all fasteners/bolts in the pilot system and on the main valve are tight and there is no damage prior to pressurizing the system.

NOTE: Pressure in some applications can be very high so be thorough in checking and inspecting for proper installation and makeup.

START-UP

CAUTION: To prevent personnel injury and damage to equipment check that downstream venting is adequate prior to start-up and test procedures. **All adjustments under pressure should be made slowly while under flowing conditions.**

1. Open the pilot ball valves (2) in the pilot system (see ZW205 schematic).
2. Loosen the pilot adjusting screw jam nut and turn the pilot adjustment screw clockwise until the spring is completely compressed. Do not over tighten to prevent damage to the valve.
3. Then slowly open the upstream shutoff valve only enough to slowly fill the main valve assembly and pilot system. Prior to pressurizing the valve assembly it is also recommended that a ZPI valve position indicator be installed to aid in verifying proper valve movement.
4. As the valve is filling with water, it is necessary to bleed the main valve and pilot system of air. To vent air, partially open or loosen the highest plugs or fittings in the system. The ZPI valve position indicator is a great location, as it has a test cock at the top to vent air pressure. It may be necessary to bleed system more than once. After removal of air in the system tighten all loose fittings. **NOTE: If valve is installed vertically, it will be necessary to loosen some upper cover bolts until you have vented all the air from the cover chamber.**
5. Before setting pilot valve, if valve is equipped with SC1 speed controls (O or L on ZW205 schematic) it is necessary to back out the adjusting screw a minimum of 3 turns from closed position.
6. Fully open the outlet gate valve if one is installed.
7. At this point, with the upstream shut-off valve partially open, it is advisable to flow water through the valve to ensure all air has escaped from the system. Slowly turn the pilot adjustment screw counterclockwise until flow starts to occur. Flow will begin to occur when the pressure set-point of the pilot decreases below the inlet pressure.
8. Allow a sufficient amount of water to flow, then turn the adjustment screw clockwise until flow stops. Fully open the up stream shut-off valve.

9. Once the system has been thoroughly bled of air, set the relief pressure by slowly turning the adjustment screw counterclockwise until water starts to flow through the ACV. Now the relief valve is set to the current inlet pressure. Use the table below to set the relief pressure if desired set point is different than the current inlet pressure. Turn the adjustment screw clockwise to increase set pressure or counterclockwise to decrease set pressure. Add or subtract from the current inlet pressure by turning the adjustment screw the number of turns required to reach the desired set pressure based on the adjustment table.

Note: The relief valve is designed for quick closing speeds. A small amount of water will dribble from the valve when the inlet pressure is as low as 80% of the set pressure during normal operation.

Relief Pilot Adjustment Range	Pressure Change per Turn (PSI)*
150-300	28.5
50-200	23
30-90	11.5
10-35	2.8
5-15	2.5

***Note: Pressure change per turn is approximate. Use a gauge at the inlet of ACV to set /check relief pressure.**

10. To verify proper operation of the ZW205, view the valve during normal operation and check the valve for relief settings. Adjustments can be made at anytime.

11. After the pilot system has been adjusted and the valve is properly operating the main valve opening and closing speed controls (O or L) can be adjusted as needed.

12. When setting speed controls, turning the adjustment screw into the speed control will restrict the amount of flow through the the needle valve. Depending on whether the control is for opening or closing (refer to ZW205 schematic) the control will either slow the opening or closing of the main valve when the adjustment screw is turned into the speed control. Adjust as needed and tighten jam nut. In general an opening speed control on a ZW205 should be at least 3 turns in from the furthest closed position to prevent high pressure surges upstream.

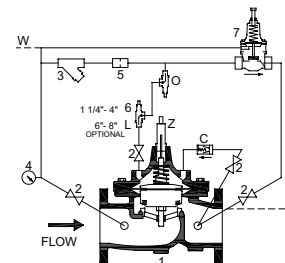

ZW205 SCHEMATIC STANDARD COMPONENTS

- Item
1. Main Valve
 2. 850XL Isolation Valve
 3. SXL "Wye" Type Strainer
 4. Pressure Gauge
 5. Restriction Fitting
 6. Closing Speed Control
 7. PV-RLF Pressure Relief Valve

OPTIONAL FEATURES

- C 40XL Hydraulic Check w/ Isolation Valve
- L SC1 Closing Speed Control (Standard 1 1/4" - 4")
- O SC1 Opening Speed Control

⚠ **WARNING:** Cancer and Reproductive Harm - www.P65Warnings.ca.gov

⚠ **ADVERTENCIA:** Cáncer y daño reproductivo - www.P65Warnings.ca.gov

⚠ **AVERTISSEMENT:** Cancer et néfastes sur la reproduction - www.P65Warnings.ca.gov

Troubleshooting

The following troubleshooting information deals strictly with the ZW205 valve and pilot systems. It is recommended to verify that the pilot system is properly functioning before troubleshooting the main valve. All troubleshooting can be performed without removing the cover. It is also recommended to permanently install a model ZPI valve position indicator.

PILOT SYSTEM FUNCTION CHECK

CAUTION: To prevent personnel injury and damage to equipment check that downstream venting is adequate prior to start-up and test procedures.

1. Turn the pilot adjustment screw clockwise all the way in.
2. Close the downstream pilot ball valve. If installed, verify the valve position indicator (model ZPI) is closed.

3. If there is continuous flow, the main valve is not sealing properly. It is recommended that the main valve be disassembled and inspected (Refer to "Disassembly" section).
4. Open the downstream pilot ball valve. If there was no flow during the previous step, but there is now continuous flow, the pilot valve is not sealing properly. It is recommended that the pilot valve be disassembled and inspected.
5. Turn the adjustment screw counter-clock wise until water starts to flow. If no water starts to flow and there is inlet pressure, then the pilot is not functioning correctly. It is recommended that the pilot valve be disassembled and inspected.
7. If the main valve and pilot valve are working properly refer to Start-Up procedures to reset the desired relief pressure and proceed with diagnosis checks for the main valve.

TABLE 1. PILOT SYSTEM TROUBLESHOOTING

<u>PROBLEM</u>	<u>POSSIBLE CAUSES</u>	<u>CORRECTIVE ACTION</u>
1. Pilot Valve not opening (relief pressure too high)	<ol style="list-style-type: none"> 1. Over compressed spring 2. Small pilot sense line clogged 3. Closed isolation ball valve 4. Worn diaphragm or stem o-ring 	<ol style="list-style-type: none"> 1. Loosen adjusting screw 2. Disassemble and clean or replace 3. Open isolation ball valve 4. Disassemble and replace diaphragm or o-ring
2. "Wye" Strainer plugged	<ol style="list-style-type: none"> 1. Clogged with debris or mineral deposits 	<ol style="list-style-type: none"> 1. Disassemble and remove obstruction
3. Pilot Valve not closing (relief pressure too low)	<ol style="list-style-type: none"> 1. Insufficient spring compression 2. Damaged spring 3. Worn seat seal or seat 4. Obstruction on seat 5. Obstruction around diaphragm 6. Worn seat o-ring 	<ol style="list-style-type: none"> 1. Tighten adjusting screw 2. Disassemble and replace parts as necessary 3. Disassemble and replace seat seal or seat 4. Disassemble and remove obstruction 5. Disassemble and remove obstruction 6. Disassemble and replace as needed

TABLE 2. MAIN VALVE TROUBLESHOOTING

<u>PROBLEM</u>	<u>POSSIBLE CAUSES</u>	<u>CORRECTIVE ACTION</u>
1. Main Valve fails to close	<ol style="list-style-type: none"> 1. No pressure at valve Inlet 2. Main valve diaphragm ruptured 3. Pilot Valve not closing 4. "Wye" Strainer plugged 5. Ball valves closed 6. Foreign matter between disc and seat or worn disc 	<ol style="list-style-type: none"> 1. Check Inlet pressure 2. Disassemble, clean, and replace defective parts 3. See pilot system troubleshooting 4. Remove, clean, and/or replace 5. Open ball valves 6. Disassemble the main valve, remove debris, clean parts, and replaced defective parts
2. Main Valve fails to open	<ol style="list-style-type: none"> 1. Scale on stem or diaphragm assembly inoperative 2. Ball valves closed 3. Pilot Valve fails to open 4. Obstruction in cover 5. Worn stem o-rings 	<ol style="list-style-type: none"> 1. Clean parts, and replace defective parts 2. Open ball valves 3. See pilot system troubleshooting 4. Disassemble and remove obstruction 5. Remove and replace as needed

When performing troubleshooting and diagnosis checks it is recommended that the following steps be performed in sequential order for best results.

DIAGNOSIS CHECKS

CAUTION: Do not service valve while under pressure. Performing diagnosis checks on the ZW205 when the valve is fully open, high flow rates and high downstream pressures can occur. In order to prevent harm to personnel, equipment, and downstream piping be sure that there are no blocked valves in the system before performing checks.

DIAPHRAGM CHECK

1. Slowly close upstream shut off valve and relieve all pressure downstream.
2. With all pressure relieved in the main valve, close both upstream and downstream pilot ball valves. Remove side plug on cover and leave off.

3. Then open upstream shut off valve partially, allowing water to flow through the valve. While flowing water monitor the opening on the cover. Water will flow from the cover as the plunger assembly rises, if water continues to flow once fully open then there is most likely damage to the diaphragm or fluid is leaking past the diaphragm assembly due to loose assembly. It is recommended that the valve cover be removed to investigate the leakage (To remove cover see "Maintenance" section for procedures). If water stops flowing out of cover then the diaphragm is good and you may proceed to the diaphragm movement check.

Note: At the beginning of this check a small amount of water coming out of the cover is normal.



DIAPHRAGM MOVEMENT CHECK

1. The diaphragm movement check can be determined during the diaphragm check by removing the top center plug or it can be performed with the use of a valve position indicator model ZPI.
2. Replace cover plugs and open pilot ball valves on upstream and cover.
3. Closing the downstream pilot ball valves will direct the flow to the cover causing it to close. **NOTE: Slow or delayed closing of main valve is normal and is due to the time requirements to fill and pressurize cover, pushing the diaphragm into the closed position. This normal delay is not mechanical binding of the valve assembly.**
4. Using the valve position indicator, make note of the closed position on the indicator. Compare distance of the open mark to the close mark and compare to Table 3. (Or by measuring to the top of the stem under center plug before and after diaphragm check)
5. Verify that the main valve is closed, by opening a downstream source. If water continuously flows, then the main valve is not sealing properly. Double check the valve movement matches the values in Table 3 and refer to the disassembly procedures section if it does not. This is an indication that the main valve is not sealing due to an obstruction between the seat and the seal, stem or a damaged seal. If water does stop flowing and the measured valve movement does not match Table 3, then there is possible damage under the cover. Remove cover to identify obstruction and replace parts as necessary.

TABLE 3. VALVE STEM TRAVEL

VALVE SIZE (in)	VALVE SIZE (mm)	STEM TRAVEL (in)	STEM TRAVEL (mm)
1-1/4" - 1-1/2"	38	0.4	10.2
2"	50	0.7	18.0
2-1/2"	65	0.8	21.3
3"	80	0.9	23.4
4"	100	1.1	28.8
6"	150	1.7	43.4
8"	200	2.4	59.7
10"	250	2.8	71.1
12"	300	3.4	86.4
14"	350	3.8	96.5
16"	400	4.3	109.2

6. For smaller valves (6" and below) diaphragm checks can be performed by hand with the use of a valve stem tool. The valve stem tool can be made using Table 4 to create a "T" bar handle with the appropriate threads on the opposite end of the "T" handle.

TABLE 4. VALVE STEM THREAD SIZE

VALVE SIZE (in)	THREAD SIZE UNF INTERNAL
1-1/4" - 1-1/2"	10-32
2"	10 - 32
2-1/2"	10 - 32
3"	1/4 - 20
4"	1/4 - 20
6"	1/4 - 20
8"	3/8 -16
10"	3/8-16
12"	3/8-16
14"	3/8-16
16"	3/8-16

7. To perform the diaphragm check using the valve stem tool, first remove all pressure in the system and vent the cover. Then remove the center plug on the cover and insert tool into the top of the stem threads. Once the tool is inserted, the valve can be lifted up and the valve movement can be measured by creating marks on the tool in the opened and closed positions. The distance between marks is the valve stem travel. Replace or repair any parts as necessary. **Caution:** water will squirt from center hole or can be vented from extra plug on cover when lifting.

SEAL RING CHECK

1. To check the seal of the valve disc, an additional pressure gauge will be needed downstream of main valve. Also isolate low flow bypass line if equipped.
2. With the valve flowing, slowly, close downstream pilot ball valves to apply pressure to cover and allow to close.
3. Open downstream source to relieve all downstream pressure and then completely close downstream shutoff valve or downstream source to close downstream system. Monitor the pressure on the inlet and installed outlet gauge, for one min. The pressure on the outlet side should remain zero. If the pressure matches inlet pressure or increases, the main valve is leaking or the outlet ball valve on the pilot system is allowing pressure to creep by. Either way it is recommended that the valve be disassembled and inspected (refer to "Disassembly" section).

Maintenance Instructions

PREVENTATIVE MAINTENANCE

The Zurn Wilkins ZW200 models require minimal maintenance. However, it is highly recommended to schedule annual inspections and to have a repair kit on hand before work begins. Valves used often may be inspected on an annual basis, but at least every five years. Valves that rarely open, should be inspected every six months to one year for water deposits, debris, or corrosion.

DISASSEMBLY

Warning: Because of the ability to perform inspections and maintenance without removal from the system, it is very important that all shut off valves be closed and all pressure relieved in the valve before beginning disassembly. Failure to do so can result in personnel injury or equipment damage.

1. Verify that all pressure sources are closed up and downstream of valve.
2. Remove pressure in pilot system by loosening the tube fittings to the valve body and cover. When all pressure has been vented, continue to disassemble the pilot control valve and cover tubing. **NOTE:** Taking a picture before tear down can help with re-assembly of pilot system.
3. Next remove the cover by loosening and removing the cover bolts. If the cover does not come off easily it may be necessary to loosen the cover using a brass chisel and rubber mallet. Apply the chisel under the cover pointing upward away from valve body and tap bottom of cover with the chisel and mallet to loosen the cover. Once the cover is loose, pull cover straight up to avoid damaging

the stem and stem bearing in the cover. On larger valves 8" and up, eye bolts and a hoist are recommended due to the weight of these larger covers.

4. With the cover removed the diaphragm assembly can be removed. To avoid damaging the seat bushing, grab the stem and lift straight up. For larger valves 8" and up it is recommended that an eye bolt with the proper stem threads be used with a hoist to lift the assembly out of the valve (see Table 4 for appropriate stem threads).
5. Next it is recommended that the diaphragm assembly be placed in a vise with the bottom hex secured. Once secured remove the spring and stem nut.
6. After inspecting the stem and removing the nut the diaphragm assembly can be dismantled. If the valve has not been serviced in awhile it is possible that the assembly will require the use of a rubber mallet or pry bars to dismantle the assembly. If this is the case gently tap or pry the components until the components are free to move. When disassembling be sure to clean, inspect, and save all components. Replace any damaged components as necessary.
7. The last component to inspect is the seat which is in the body of the main valve. During inspection of the seat, clean and polish as necessary with fine grit wet/dry sandpaper (400 grit or higher). Typically, if after cleaning there is no visual damage or excessive wear the seat should not require removal. If damage is present or the seat is excessively worn the seat should be replaced.



8. To remove the seat, on valves 6" and smaller the seat is threaded into the body and will require a seat removal tool. Care should be taken when removing the seat to avoid damaging. On 8" and larger valves, the seat is held in place with flat head hex screws. For larger valves a seat puller may be required to remove the seat from the body. A seat tool may be made by grinding three notches for the spokes in the end of a pipe. Turn with a pipe wrench.

INSPECTION OF COMPONENTS

Cleaning of components is required for proper inspection. Lime deposits are common in systems that use water. To remove deposits, fine grit wet/dry sandpaper (400 grit or higher) can be used. If deposits cannot be removed, off the shelf lime deposit remover can be used. Prepare a solution following the lime deposit remover instructions and soak components (excluding rubber components) until lime deposits are removed.

CAUTION: When handling chemicals (acids) be sure to use proper safety equipment (gloves and eye protection) and practices. After soaking components, be sure to thoroughly rinse all components before handling and re-assembling valve.

Once all valve components have been cleaned, inspect each component looking for damage, abnormal wear & corrosion, and replace all components that look questionable. Replace all rubber components including the diaphragm, o-rings and disc each time the valve is serviced or inspected (rubber components are standard in ZW200 repair kits).

REASSEMBLY

1. First reinstall seat into body. Be sure to use lube around seat o-ring before tightening. Tighten seat according to torque values in Table 5 using seat tool.
2. Next place valve stem in a vise clamping on the hex portion of the stem. Then assemble the diaphragm assembly as shown in Figure. When assembling be sure that the diaphragm is centered on the raised step of the disc retainer. It is also recommended to apply lube to stem threads and o-rings before tightening. Then tighten the stem nut according to Table 5 for torque values.
3. Lower diaphragm assembly carefully into the seat bushing. Be careful not to damage the seat or stem while installing assembly. Rotate the assembly as needed until the bolt holes on the diaphragm line up with the body bolt holes.
4. Place lower spring disc on the diaphragm disc and place spring on top of the assembly. Then install cover, aligning the bolt holes and insuring that the cover is not pinching the diaphragm between the bolt holes. Position cover so plug holes are in original position.
5. Install cover bolts and tighten in a star pattern to the torque values in Table 5.
6. Before installing center cover plug manually check that assembly has full operating travel before installing the pilot assembly (refer to "Diaphragm Movement" in the diagnosis checks section).
7. Once full operation range of the main valve is verified, begin reinstalling pilot system.
8. After installing pilot system double check that all plugs, bolts, and fittings are sealed and tight before applying pressure.
9. Slowly open upstream isolation valve to pressurize the system and check for any leaks.

10. Stop leaks as needed and proceed to "Start-Up" and "Diagnosis Check" sections for returning valve to proper system operations.

TABLE 5. VALVE TORQUE SETTINGS

VALVE SIZE (in)	COVER (ft-lbs)	DIAPHRAGM ASSEMBLY (ft-lbs)	THREADED SEAT (ft-lbs)	SEAT BOLTS (ft-lbs)
1-1/4"	3.5	7.5	11	N/A
1-1/2"	3.5	7.5	11	N/A
2"	15	20-25	30	N/A
2-1/2"	25	25-35	60	N/A
3"	25	35-45	70	N/A
4"	55	40-50	85	N/A
6"	110	50-60	95	N/A
8"	120	60-70	N/A	7.4
10"	184	70-75	N/A	7.4
12"	200	110-115	N/A	7.4
14"	275	170-175	N/A	7.4
16"	360	230-240	N/A	7.4

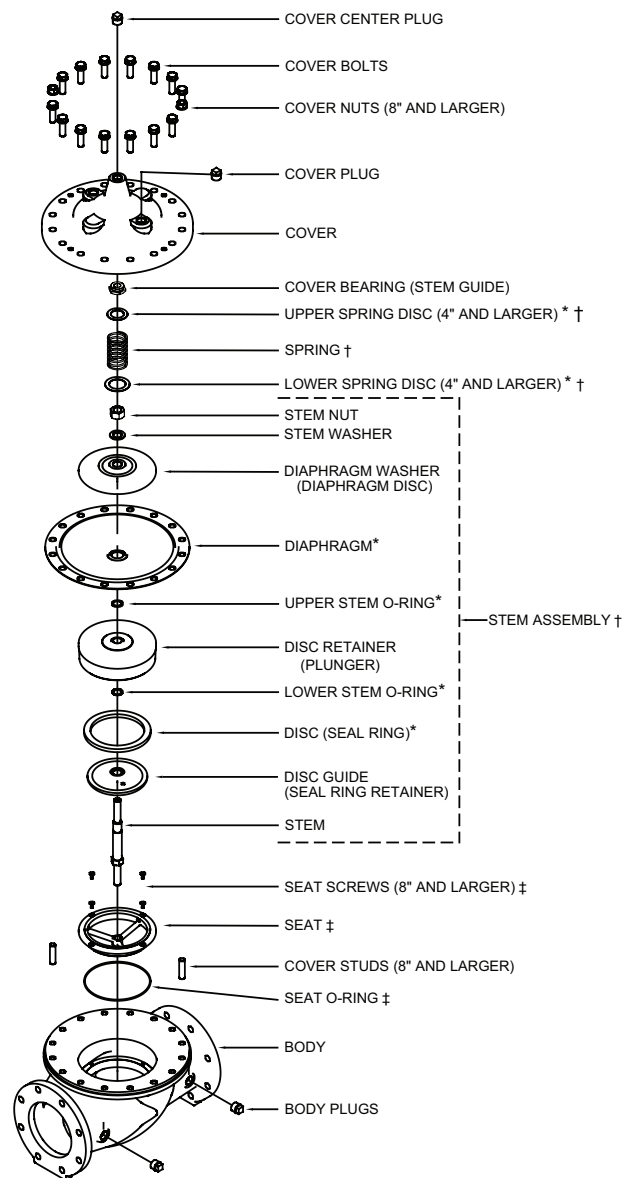

* RUBBER REPAIR KIT ITEMS
 † COMPLETE REPAIR KIT ITEMS
 ‡ SEAT REPAIR KIT



Maintenance (PV-RLF Valve)

The PV-RLF Pressure Relief Valve may be installed in any position. The flow direction is shown below. Flow goes from the narrow side to the wide side of the cast body.

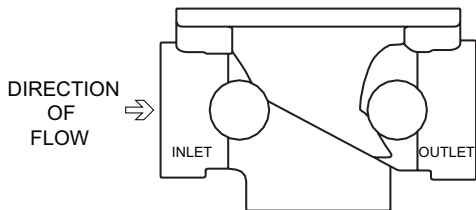

Disassembly

Prior to disassembly, relieve all pressure in pilot system and then remove the PV-RLF.

1. Secure valve body and turn the adjustment screw all the way out.
2. Next remove 8 socket head screws around the pilot bell using a 5/32" hex key. Remove the bell, the spring, and 2 spring discs.
3. Remove the spacer and remove small gasket from the bottom of the spacer. Use a 12mm socket or adjustable wrench on the diaphragm and plunger nuts to disassemble the plunger/diaphragm assembly. Unscrew one end of the stem.
4. At this point slide the plunger/diaphragm assembly out of the valve spacer.
5. Use soft jaws or a towel and pliers to clamp the stem. Be careful not to scratch the stem as this is an o-ring surface. Use an adjustable wrench on the opposite nut to remove the remaining plunger/diaphragm assembly.
6. The parts removed from the disassembled diaphragm and plunger assembly are a plunger, small washer, 2 o-rings, 2 nuts, a medium washer, a large washer, diaphragm, and lock washer.
7. Use a small pin or pick to carefully remove the o-ring on the inside through hole of the spacer. Do not scratch brass surface.
8. After complete disassembly thoroughly clean and inspect all components before reassembly. Replace parts as necessary after inspection.
9. The pilot seat generally does not need to be removed, but if after inspection it requires replacement it can be removed with a 1-1/16" socket.

PV-RLF Valve Reassembly

Reassembly of the PV-RLF is the reverse of disassembly.

1. Carefully install a new o-ring in the through hole of the spacer.
2. Place the medium washer (with round outer edge toward the diaphragm) on the side of the stem with the chamfered tip.
3. Follow the washer by putting on a new o-ring, new diaphragm, large washer (with the inner step against the diaphragm), lock washer, and 5/16" (chamfered side away from diaphragm) nut then hand tighten.
4. Slide the stem through the spacer with the diaphragm assembly on the spacer side with a circular groove on the top surface.
5. On the other side of the stem place the small washer, o-ring, plunger (with the rubber facing away from the spacer), and nut.

6. Use adjustable wrenches to tighten the plunger and diaphragm nuts, on stem through spacer.
7. Place small gasket on bottom of valve spacer.
8. Install the plunger assembly on to the body with the plunger sitting on the valve seat. The small rubber gasket on the plunger side of the spacer must cover the sensing hole on the pilot body.
9. Place a spring disk on the stem, then the spring, another spring disk and bell.
10. Insert socket head cap screws into pilot bell holes and thread into valve body. Place model tag on the four screws that straddle the body inlet. Tighten all screws in a cross pattern.
11. Install adjusting screw by hand with jam nut. Set valve once reinstalled into pilotry system. Refer to "Start-up" section on page one for proper setting of relief pilot. For further assistance or ordering replacement parts go to www.zurn.com or call product support 855-663-9876.

Table 1

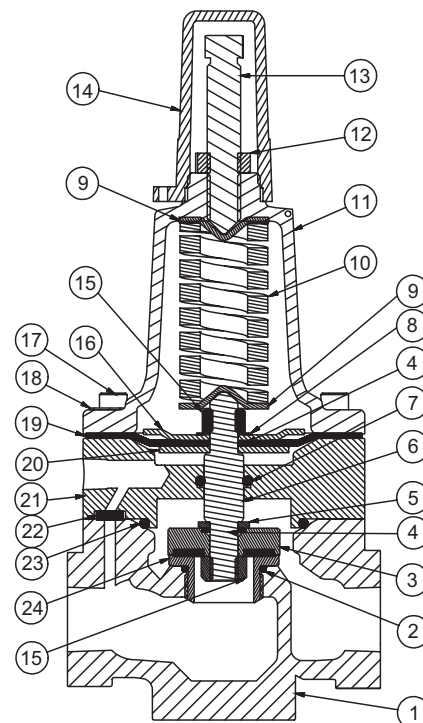

ITEM	DESCRIPTION
1	1/2" Relief Body
2	O-ring Buna Nitrile, NSF Listed
3	Relief Plunger Assy.
4	Diaphragm O-ring
5	5/16" Flat Washer
6	Relief Pilot Stem
7	O-ring, Buna Nitrile, NSF Listed
8	5/16" Internal Tooth Lock Washer
9	Spring Disc
10	Spring
11	Pilot Bell
12	3x8-16 Jam Hex Nut

ITEM	DESCRIPTION
13	3/8-16 Adjustment Bolt
14	Adjustment Cover
15	5/16-18 Diaphragm Nut
16	Relief Pilot Upper Diaphragm Disc, SS
17	10-32 X 1-1/2" Skt Hd Cap Screw, SS
18	Tag
19	Diaphragm
20	Relief Pilot Lower Diaphragm Washer
21	Relief Pilot Spacer
22	Sensing Hole Gasket
23	O-ring, Buna Nitrile, NSF Listed
24	Relief Pilot Seat

Flow Characteristics

BODY MINIMUM FRICTION LOSS

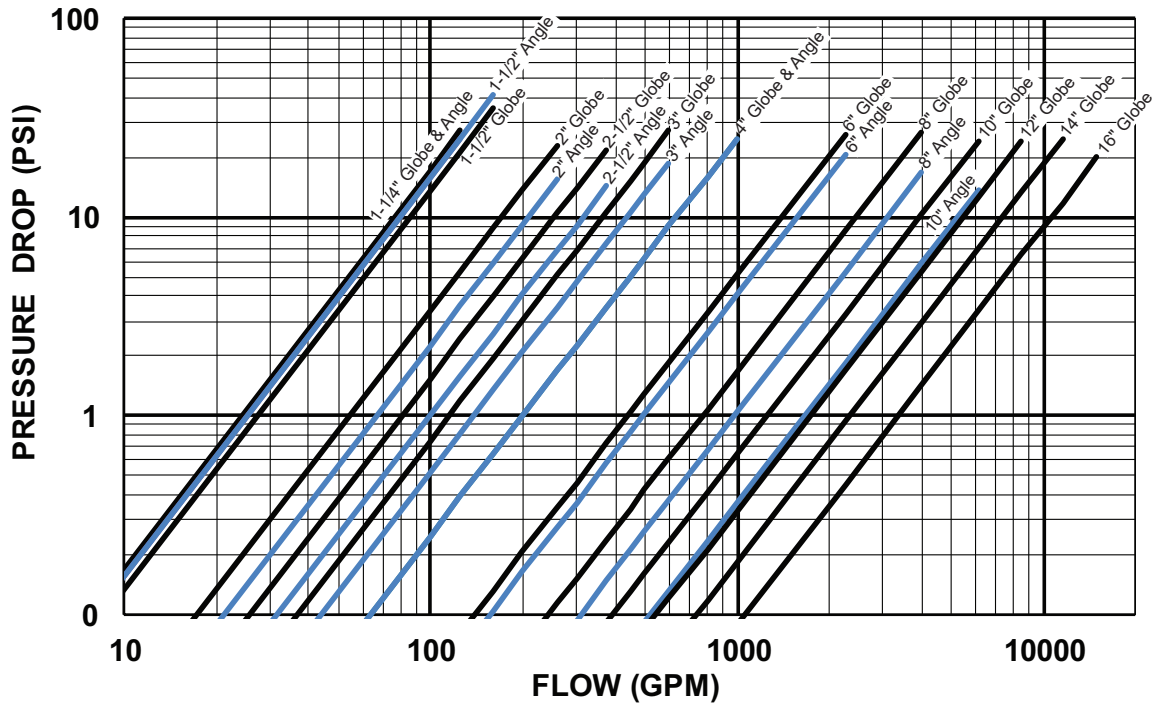

Note: If the valve discharges to atmosphere regularly adequate back pressure is very important to prevent damage to valve, throttle discharge from valve with a gate or butterfly valve.