



# AquaSense®

## ZTR Series

### Automatic Sensor-Operated Piston Type Flushometer for Water Closets and Urinals

### Installation, Operation, Maintenance and Parts Manual



#### Water Closet Models:

ZTR6200-ONE	1.1 gpf
ZTR6200EV	1.28 gpf
ZTR6200-WS1	1.6 gpf
ZTR6200-WS1-DF	1.6/1.1 gpf

#### Urinal Models:

ZTR6203-ULF	0.125 gpf
ZTR6203-QRT	0.25 gpf
ZTR6203-EWS	0.5 gpf
ZTR6203-WS1	1.0 gpf

#### Power Options:

- Battery (Standard)
- LL (Long Life Battery)
- HW (Hardwired using 7.6 VDC Power Supply Input)

#### Compliance:

- ADA Compliant - Operational Controls
- WaterSense Compliant

⚠ **WARNING:** Cancer and Reproductive Harm - [www.P65Warnings.ca.gov](http://www.P65Warnings.ca.gov)

⚠ **ADVERTENCIA:** Cáncer y daño reproductivo - [www.P65Warnings.ca.gov](http://www.P65Warnings.ca.gov)

⚠ **AVERTISSEMENT:** Cancer et effets néfastes sur la reproduction - [www.P65Warnings.ca.gov](http://www.P65Warnings.ca.gov)

#### LIMITED WARRANTY

All goods sold hereunder are warranted to be free from defects in material and factory workmanship for a period of three years from the date of purchase. Decorative finishes warranted for one year. We will replace at no costs goods that prove defective provided we are notified in writing of such defect and the goods are returned to us prepaid at Sanford, NC, with evidence that they have been properly maintained and used in accordance with instructions. We shall not be responsible for any labor charges or any loss, injury or damages whatsoever, including incidental or consequential damages. The sole and exclusive remedy shall be limited to the replacement of the defective goods. Before installation and use, the purchaser shall determine the suitability of the product for his intended use and the purchaser assumes all risk and liability whatever in connection therewith. Where permitted by law, the implied warranty of merchantability is expressly excluded. If the products sold hereunder are "consumer products," the implied warranty of merchantability is limited to a period of three years and shall be limited solely to the replacement of the defective goods. All weights stated in our catalogs and lists are approximate and are not guaranteed.

**NOTICE: READ ENTIRE MANUAL PRIOR TO INSTALLING PRODUCT**

# ZTR Series Flush Valve Package Contents

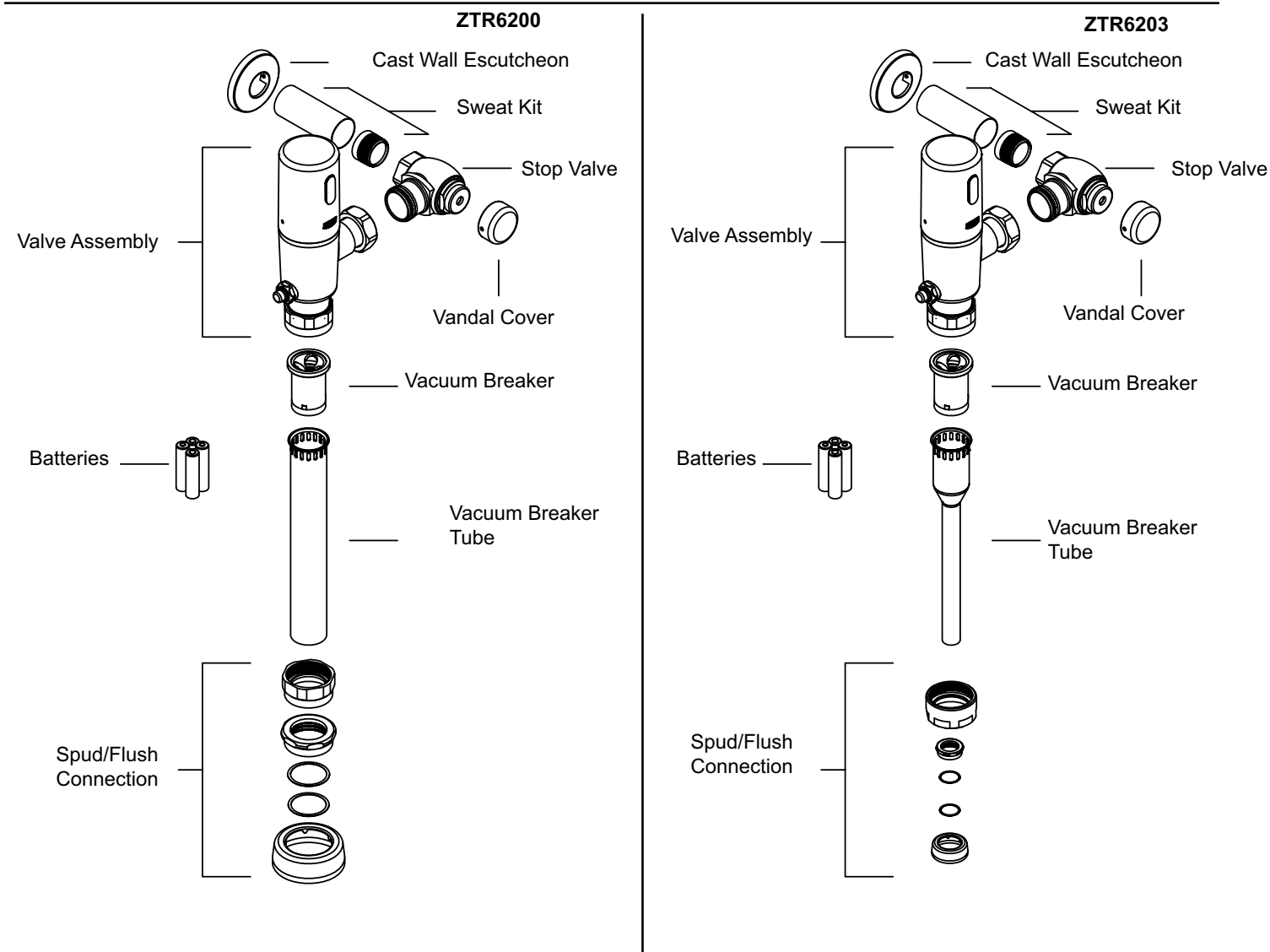

## Overview:

Zurn Aqua-Sense® ZTR Series Flushometer offers two models (closet/urinal) in a variety of flow rates. The ZTR design is a chrome plated brass body with an automatic sensor-operated piston-type valve. The flushometer incorporates a filtered bypass, high back pressure vacuum breaker, adjustable tailpiece, spud coupling, flange for top spud connection and a mechanical override pushbutton (MOB) for alternative flushing methods. The control stop has internal siphon-guard protection, vandal resistant stop cap, sweat solder kit, and cast wall flange with set screw. All internal and external gaskets and seals are chloramine resistant.

## Specifications:

Voltage: 6 VDC Series [4 "AA" (Alkaline or Lithium) and/or external power option]

Sensor Range: Factory set for user at end of elongated bowl or field adjustable by installer

## Important Safety Information:

- Installer is responsible for ensuring the product is installed and conforms to all plumbing codes and ordinances.
- Do not convert or modify this Zurn product yourself. All warranties will be voided.
- Water supply lines must be sized according to building designer in order to provide adequate water supply for each fixture.
- Flush all water lines prior to making connections.

## Prior to Installation:

- The ZTR flushometer is designed to operate optimally between 25 psi (running) to 80 psi (static) water pressure (172 to 552 kPa). Higher running pressure may be required for some fixtures. Consult fixture manufacturer for details.
- When installing a flushometer, it is important that the flush volume matches the requirements of the plumbing fixture.
- To protect chrome finish, do not use toothed tools to install or service the flushometer.
- Before installing your Zurn® Aqua-FIT® Faucet: the items listed below should already be installed on site.
  - Closet
  - Fixture carrier
  - Drain line
  - Water supply line

## Required Tools

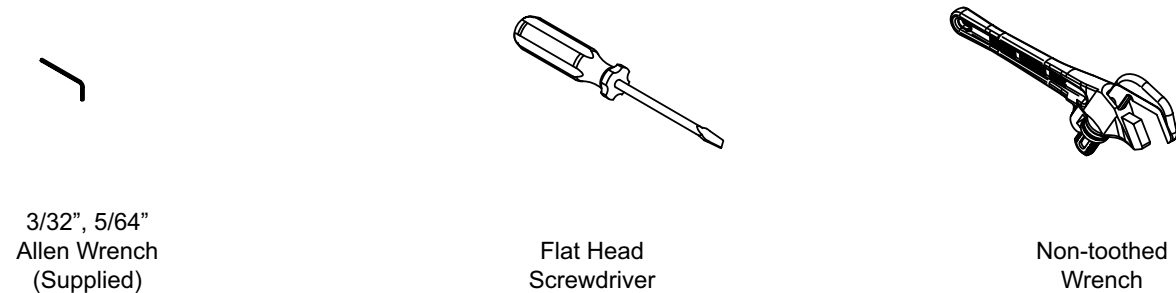

## Optional Accessories



**NOTE:** The information in this manual is subject to change at any time without notice. Installations may be performed at different times of construction by different individuals. For this reason, these instructions should be left on-site with the facility or maintenance manager.

## Sweat Solder Adapter Installation Instructions - STEP 1

**NOTE:** Before installation, turn off water supplies to existing fixture and remove flushometer if replacing an existing device.

### STEP 1.1

Measure distance from finished wall to the center line of the fixture spud. If necessary, cut water supply pipe 1-1/4" shorter than this measurement. Deburr by chamfering O.D. and I.D of end of water supply pipe.

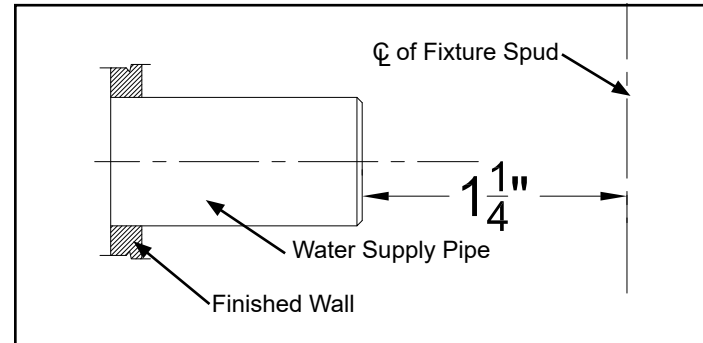

### STEP 1.3

Measure distance from finished wall to first thread of sweat solder adapter. If necessary, cut chrome cover tube this length.

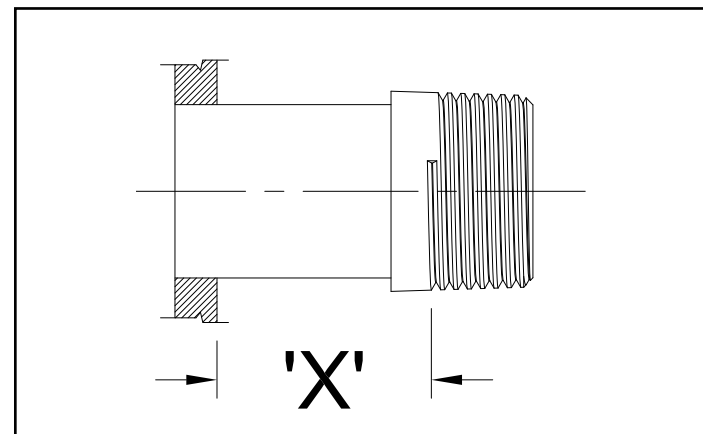

## Control Stop Installation Instructions - STEP 2

### STEP 2.1

Install control stop assembly by threading it to the water supply pipe and tightening with a smooth jawed wrench. Apply thread sealing compound or pipe tape to male NPT thread on sweat solder adapter. This is the only area where use of tape/compound is approved.

**⚠ THIS IS THE ONLY USE OF TAPE OR COMPOUND DURING FLUSHOMETER INSTALLATION.**

Prior to turning on main water supply line ensure all stop valves are closed off tight by using a flathead screwdriver and turning the stop valve adjustment screw clockwise.

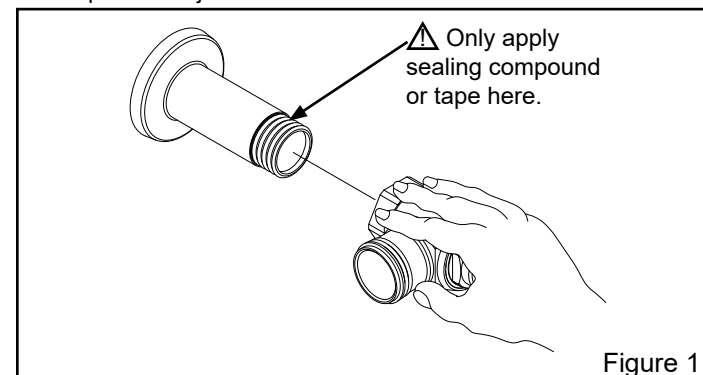
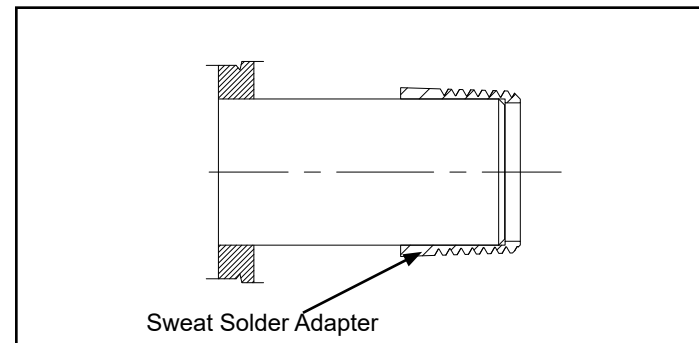

Figure 1

### STEP 1.2

Slide threaded sweat solder adapter onto water supply pipe until shoulder stops on end of pipe. Then sweat-solder the adapter to water supply pipe.



### STEP 1.4

Slide wall escutcheon over chrome cover tube and slide both items over water supply pipe. Press wall escutcheon flush against finished wall and tighten set screw with hex wrench (supplied) to secure it in place.

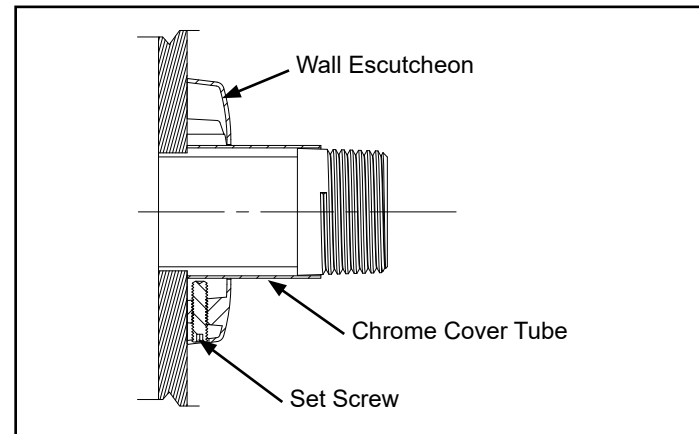

### STEP 2.2

When the stop valve is properly connected and water pressure is available, open the control stop with a flathead screwdriver by turning the stop valve adjustment screw counterclockwise. Allow the water supply line to flush any debris or sediment that may be present in the line. Close the control stop once the lines are completely flushed.

**⚠ ALL DEBRIS MUST BE PURGED FROM WATER SUPPLY LINE PRIOR TO FLUSHOMETER INSTALLATION**

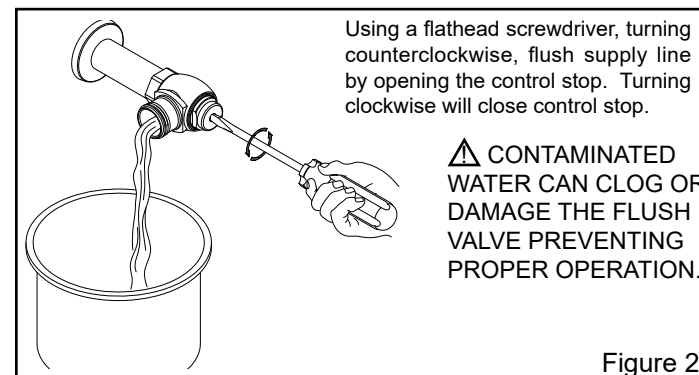

Figure 2

## Flush Valve Installation - STEP 3

### STEP 3.1

Prior to attaching flush valve to control stop(A), inspect the tailpiece and verify the locking nut (D) and locking snap ring (E) are present and O-ring (C) properly sits in the O-ring groove. Next, grip the shipping plug handle (F) and slowly pull downward to remove and discard from the valve body. This positions the piston for initial start. See Figure 3.

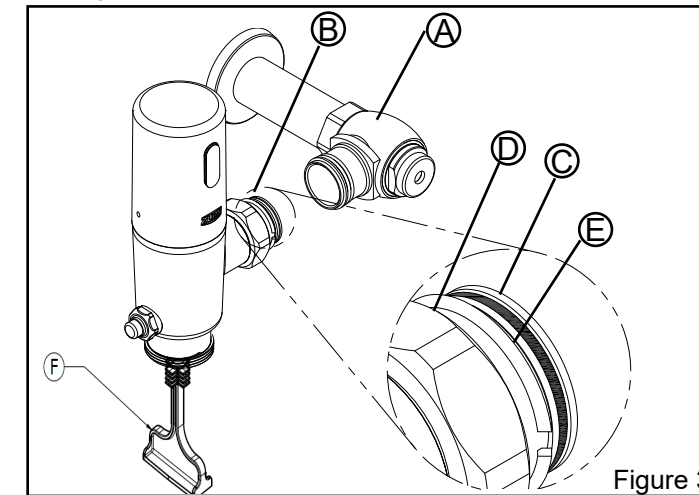

Figure 3

### STEP 3.3

Determine the length of vacuum breaker tube required to join the flush valve and fixture spud, and cut if necessary. See Figure 5.

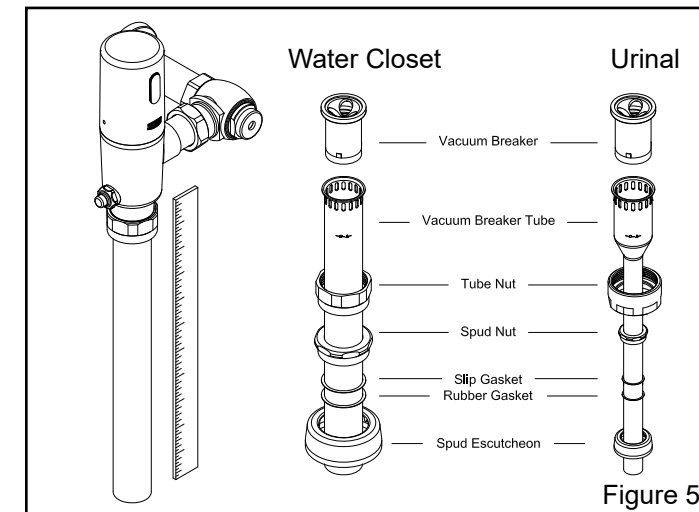

Figure 5

## Remove Sensor Cap (Applies to all versions) - STEP 4

### STEP 4.1

Use the 3/32" Allen Wrench to loosen the internal set screw until it stops. Screw will retract into the base to eliminate loss.

### STEP 4.2

Rotate cap clockwise and pull cap up to remove.

### STEP 4.3

Disconnect black solenoid plug before accessing batteries.

### STEP 3.2

Lubricate O-ring with water if necessary and carefully insert flush valve tailpiece into the control stop valve to ensure O-ring remains seated. Tighten locking nut using a smooth jawed wrench. See Figure 4.

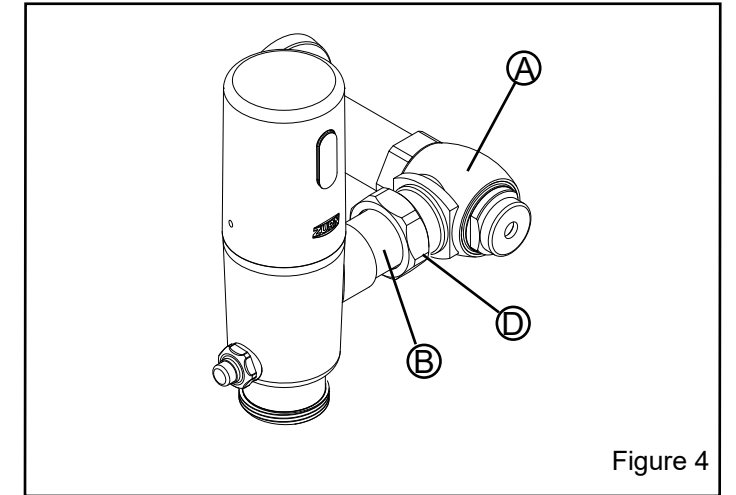

Figure 4

**⚠ DO NOT use pipe sealant or plumbing grease on any valve component or coupling with the exception of the Control Stop Inlet! Ensure Vacuum Breaker does not twist or warp when tightening Vacuum Breaker Tube Nut.**

### STEP 3.4

Assemble and secure the vacuum breaker tube assembly and spud nut assembly to the flush valve and fixture spud by hand tightening the spud nut and vacuum breaker tube nut.

Adjust and plumb the valve assembly. Tighten all connections with smooth jawed wrench and turn on water supply at the control stop. See Figure 5.

**⚠ DO NOT cut vacuum breaker tube shorter than 6" below the -C-L- indicator mark, as vacuum breaker must be 6" above the fixture. Consult plumbing Codes & Regulations for specific details.**

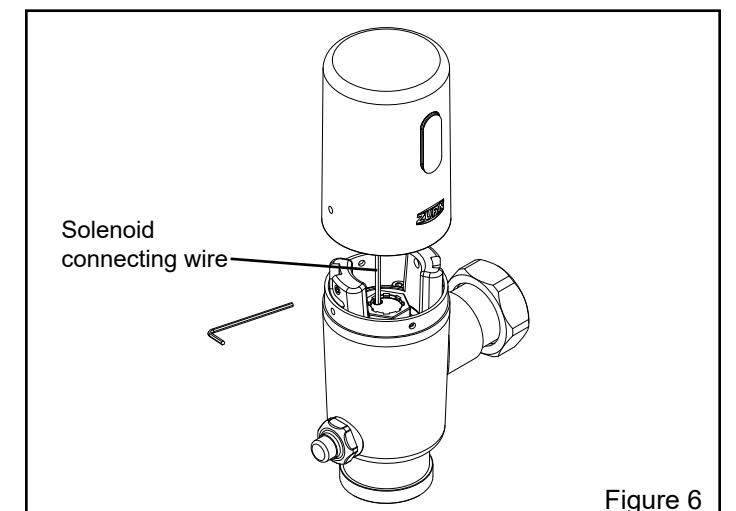

Figure 6

## Battery Installation (Applies to battery and -LL versions only) - STEP 5A

### STEP 5A.1

Carefully remove the sealed battery housing from the sensor cap (do not pull wires). Unscrew the knurled screw to open the lid for access the battery area. Insert four batteries (supplied) into the sealed battery housing noting the correct orientation by the + inside the housing base. Reattach the housing top lid by aligning the arrows on the side and tightening the knurled screw.

#### Wire Connection Order

1. The **90° Black Solenoid Connector** and the **Black Sensor Lens Connector** should be connected first.
2. The **Straight Red Battery Connector** to the **Straight Red Sensor Lens Connector** should be connected second.

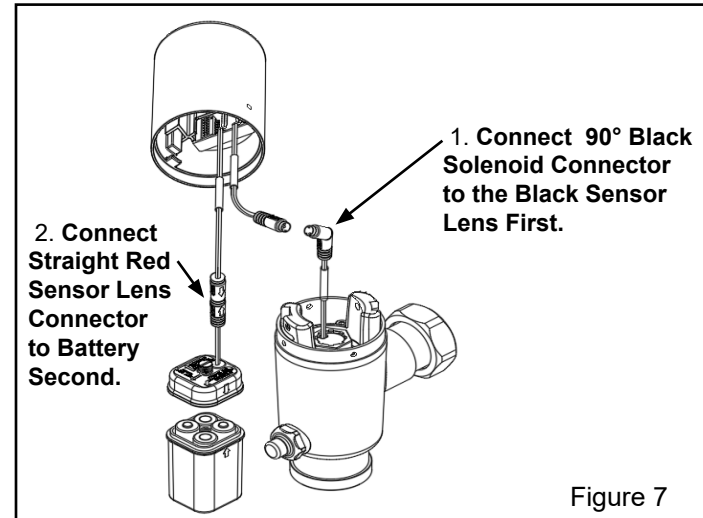

Figure 7

⚠ Only use one battery type for installation. **DO NOT** mix and match Standard (Alkaline) and Long Life (Lithium) Batteries.

## Hardwire Installation (Applies to -HW versions only) - STEP 5B

### STEP 5B.1

Route 10' power supply cable (supplied) through the wall escutcheon (supplied), wire supply tube (supplied) and the opening on the back of sensor cap.

Connect power supply cable to sensor lens via **RED** connectors by aligning arrows and pressing together.

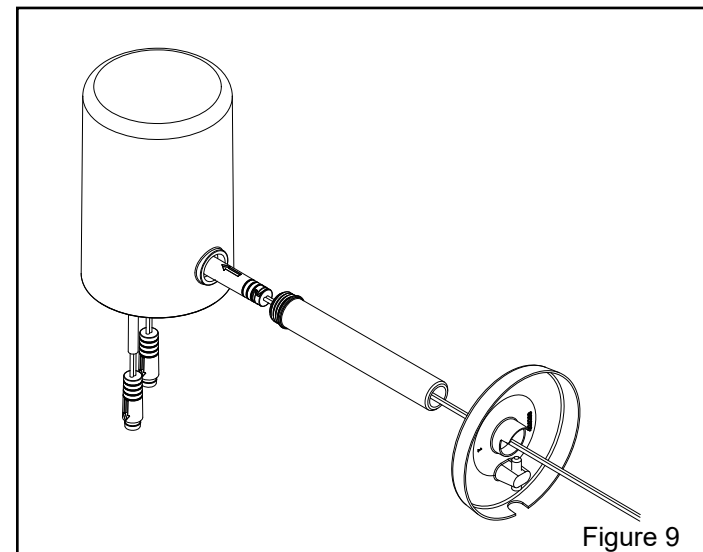

Figure 9

### STEP 5A.2

On the black connectors, align the female 90° solenoid connector holes and alignment slot with the pins in the straight sensor connector and lock together

Then, align the 2 arrows on the side of each red connector and then push to lock together. See Figure 8.1.

Stow the connectors per the directional arrows on the battery's top lid. The straight red connector pair is designed to be inserted vertically down the side of the battery housing. The 90° black pair lays on top of the cap sensor per the black arrow. See Figure 8.2.

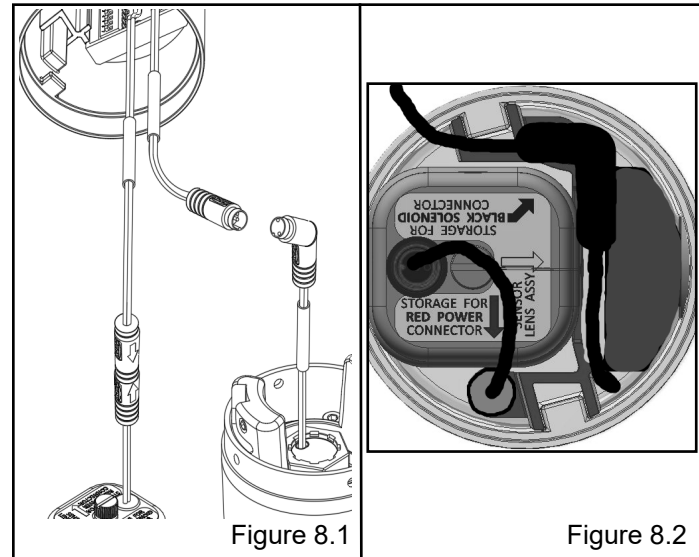

Figure 8.1

Figure 8.2

### STEP 5A.3

Reattach the sensor cap and tighten cap screws.

Hand-tighten wire supply tube into the back of the sensor cap. Slide wall escutcheon along wire supply tube until it is against the sensor cap.

Reattach the sensor cap to the flushometer valve body while ensuring wire supply tube is properly inserted into thru-hole in wall.

Tighten the set screw using 3/32" Allen wrench to secure sensor cap. Slide wall escutcheon flush with wall and secure using set screw and Allen wrench (supplied).

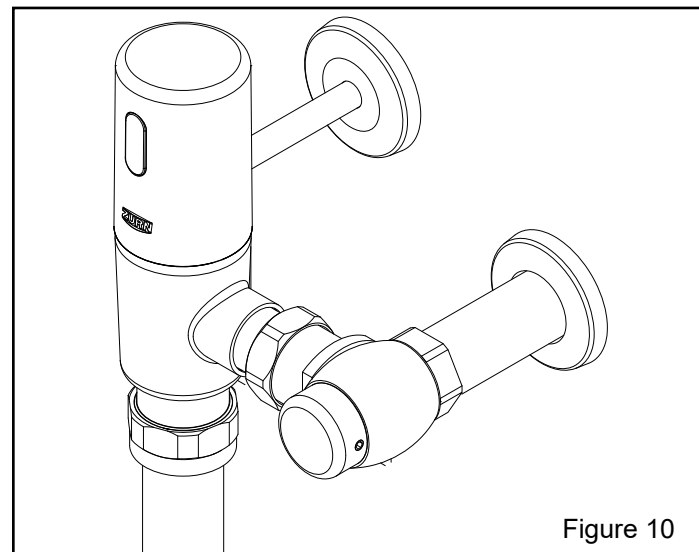

Figure 10

Connect ZTR-HW directly to HW6 Power Converter. (Recommended if one to two ZTR flush valves are powered by one HW6.)

### STEP 5B.2

Cut **RED** power connector from end of power supply cable not connected to the Sensor Cap and strip back the wire insulation by minimum of 1/4".

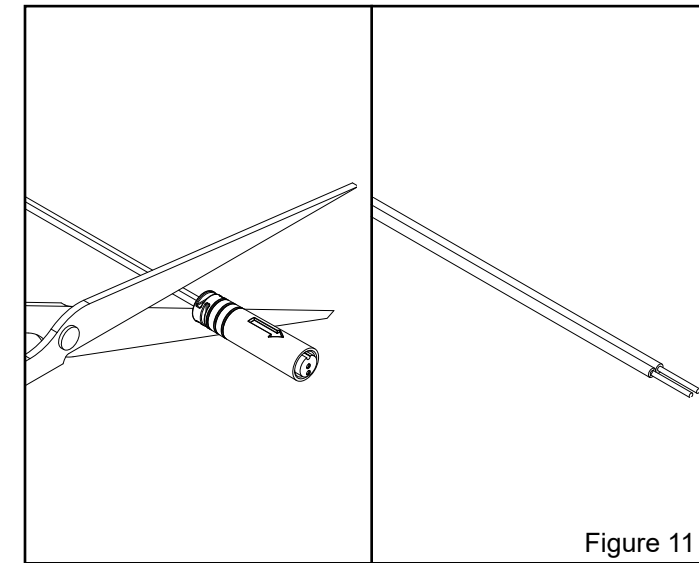

Figure 11

### STEP 5B.3

Secure **RED** wire to Positive (+) and **BLACK** wire to Negative (-) screw terminals on HW6.

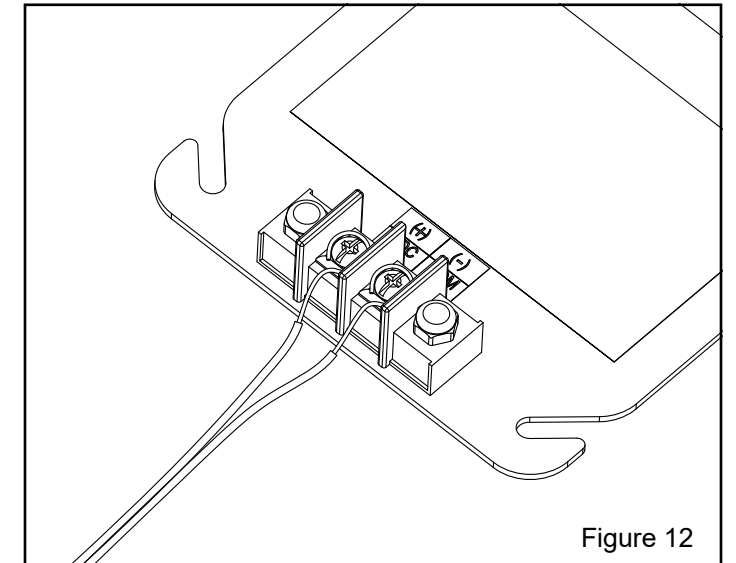

Figure 12

Optional Junction Box (recommended when three or more ZTR flush valves utilize one HW6)

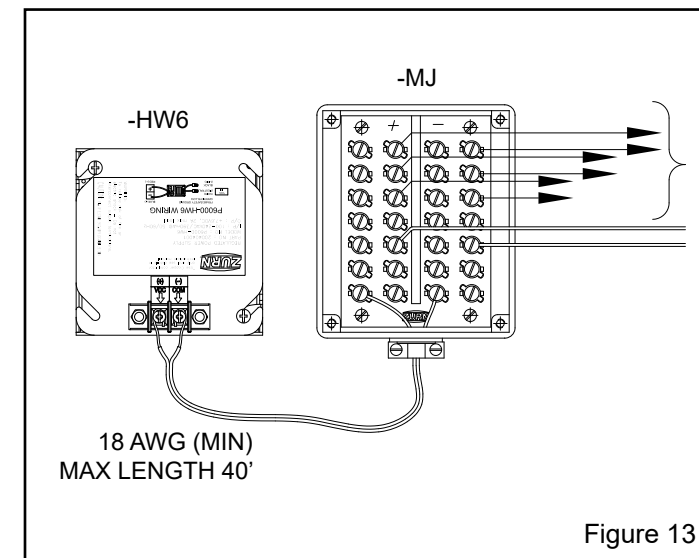

Figure 13

# Metal Sensor Cap Retrofit Installation Instructions

## STEP 6.1

Remove vandal-resistant cover with allen wrench from control stop (if present) and turn control stop clockwise to turn off the water supply.

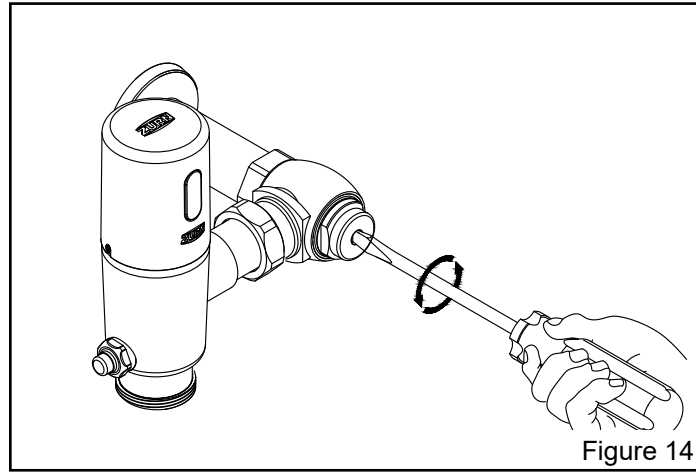

Figure 14

## STEP 6.3 (For Hardwired Only)

Loosen set screw in wall escutcheon and slide escutcheon against the sensor cap

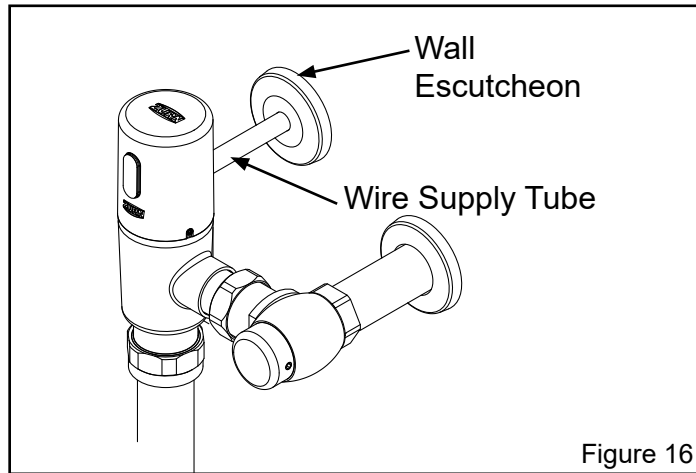

Figure 16

## STEP 6.5 (For Hardwired Only)

Disconnect the red sensor plug and loosen the wire supply tube. Remove both the wire supply tube and escutcheon. Keep for metal sensor cap installation.

## STEP 6.6

Remove the 4 socket screws shown in Figure 18 using a M3 allen wrench and discard the screws

## STEP 6.2

Press and hold the manual override button for 3 seconds to release any residual pressure.

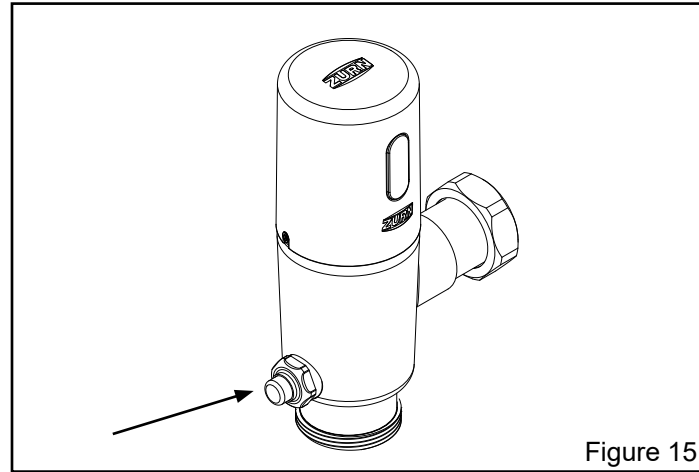

Figure 15

## STEP 6.4

Use a 5/64" allen wrench to remove the two cap screws from the sensor cap and remove the sensor cap. See Figure 17. Disconnect black solenoid plug.

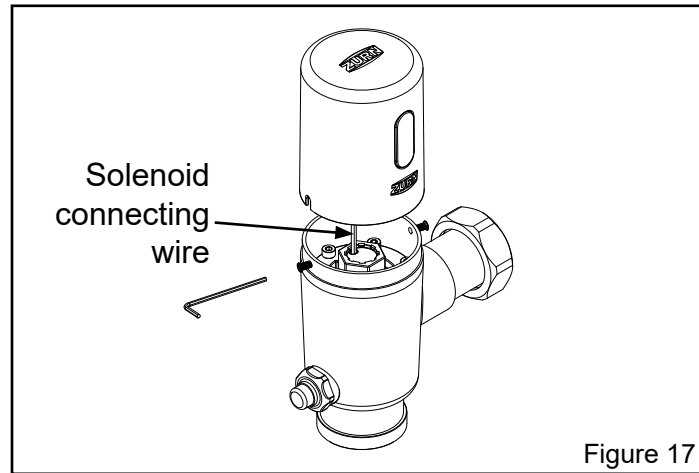

Figure 17

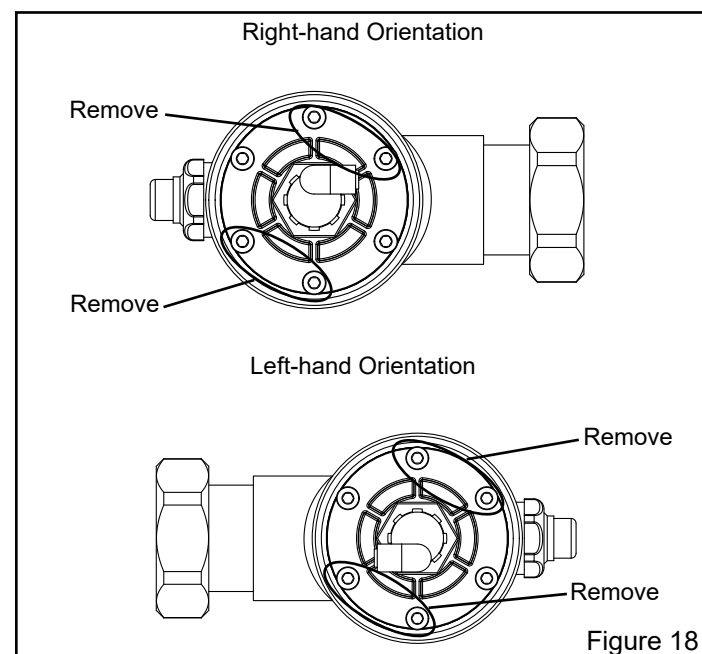

Figure 18

## STEP 6.7

Note socket screw pockets in the ring insert and place over remaining 2 socket screws See Figure 19.

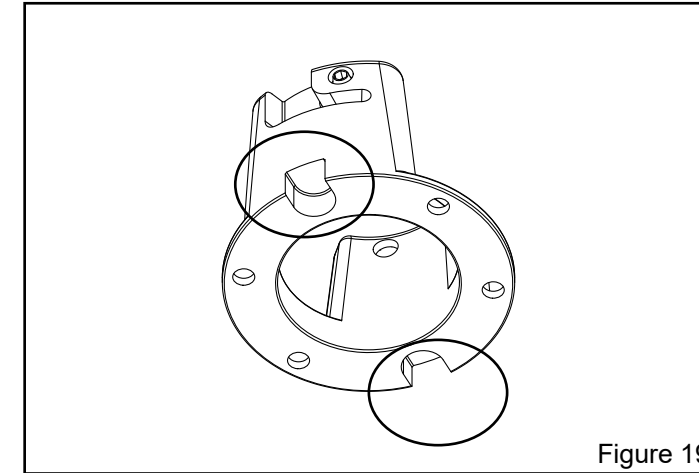

Figure 19

## STEP 6.9

Carefully remove the sealed battery housing from the sensor cap (do not pull wires). Unscrew the knurled screw to open the lid for access the battery area. Insert four batteries (supplied) into the sealed battery housing noting the correct orientation by the script inside the housing base indicating + (plate) and - (spring). Reattach the housing top lid by aligning the arrows on the side and tightening the knurled screw.

## STEP 6.10

Insert sealed battery housing into sensor cap. Ensure sticker on top of sealed battery housing is oriented properly with the **WHITE** arrow pointing toward the sensor lens. See Figure 23 and 24.

### Wire Connection Order

1. Confirm the connection of the **90° Black Solenoid Connector** and the **Black Sensor Lens Connector** First.
2. Insert the **Straight Red Battery Connector** to the **Straight Red Sensor Lens Connector** by aligning the arrows. See step 5A.2 for wire connection information.

Stow the connectors per the directional arrows on the battery's top lid. The straight red connector pair is designed to be inserted vertically down the side of the battery housing. The 90° black pair lays on top of the cap sensor per the black arrow. See Figure 24.

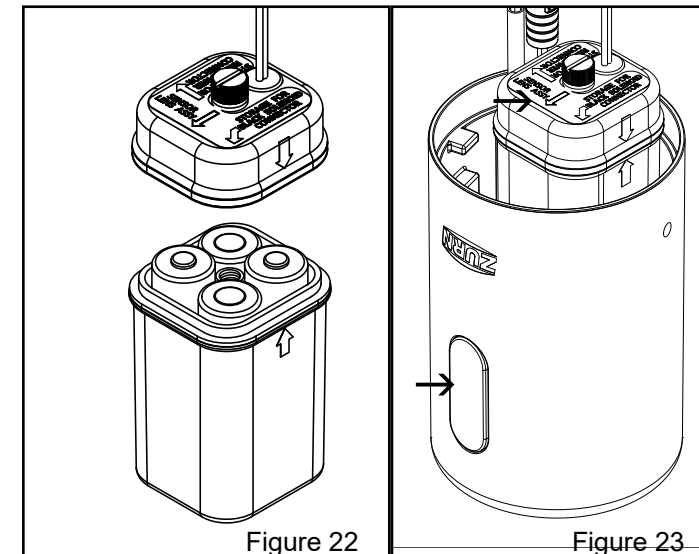

Figure 22

Figure 23

## STEP 6.8

Ensure ring insert set screws align with valve body holes shown in Figure 20. Hand start the 4 new sockets screws (included) into the ring insert. Tighten screws in the torque sequence shown on Figure 21.

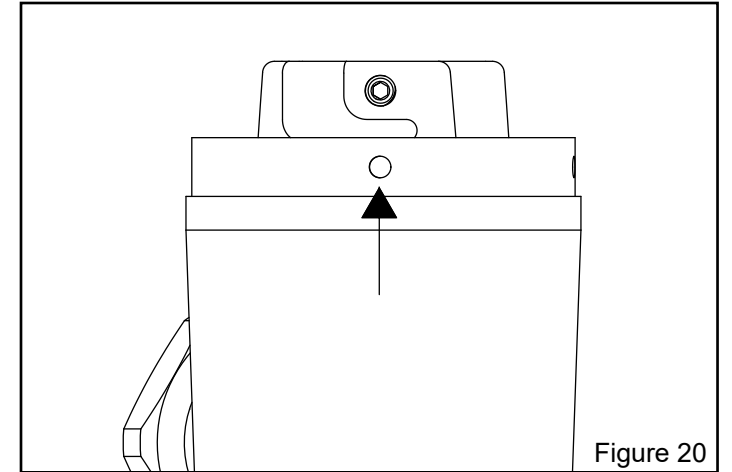

Figure 20

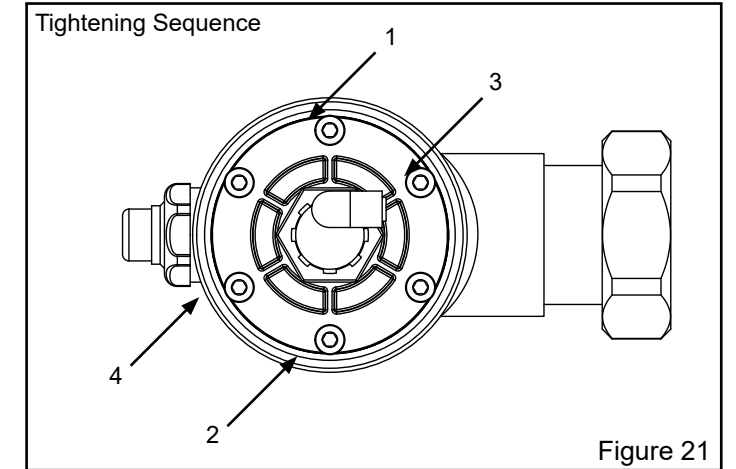

Figure 21

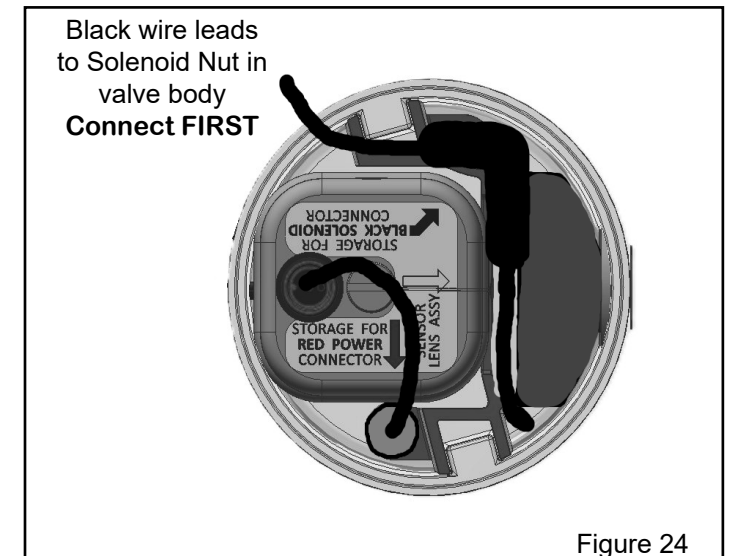

Figure 24

### STEP 6.11 (For Hardwired Only)

Route 10' power supply cable through the wall escutcheon, wire supply tube, and the opening on the back of the metal sensor cap.

Connect the power supply cable to the sensor lens via the **RED** connectors by aligning the arrows and pressing together.

Hand-tighten wire supply tube into the back of the sensor cap. Slide wall escutcheon along wire supply tube until it is against the sensor cap.

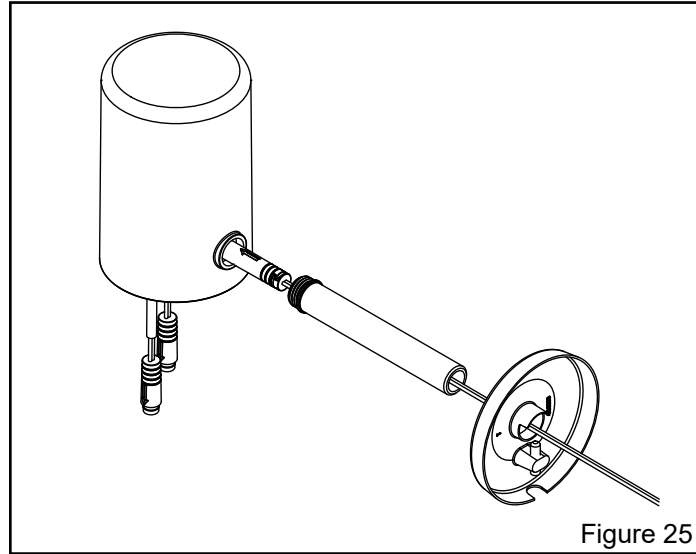

Figure 25

### STEP 6.12

Align set screw hole in sensor cap with key way in ring insert and place sensor cap on valve body.

Rotate sensor cap counter clockwise until the set screw is visible in the sensor cap hole and the sensor is facing forward. Using the 3/32" allen wrench (provided) rotate the set screw clockwise to secure the cap.

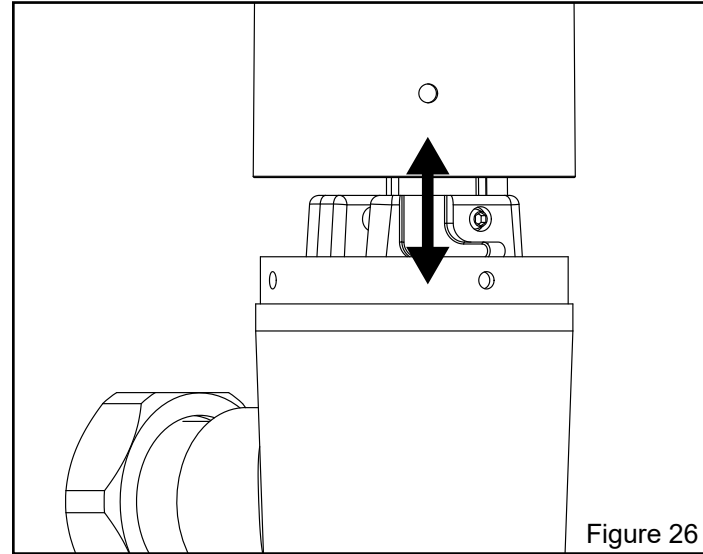

Figure 26

## Dip Switch Settings (when necessary)

### Courtesy Flush

A courtesy flush can be enabled for the ZTR flushometer where the valve will automatically flush at a specified interval based on customer preference. Simply manipulate Dips witches #2 and #3 located on the Sensor Lens found on the inside of the Sensor Cap to change the courtesy flush interval.

Courtesy Flush Interval	Dipswitch #2	Dipswitch #3
Disabled (Default Setting)	ON	ON
24 hours	ON	OFF
48 hours	OFF	ON
72 hours	OFF	OFF

### Dual Flush Option (If Equipped)

The dual flush option can be enabled by turning switch #1 to the **ON** position.

Note: The ZTR Dual Flush must be originally ordered with the dual flush option. Regular single flush valves will not function in dual flush mode.

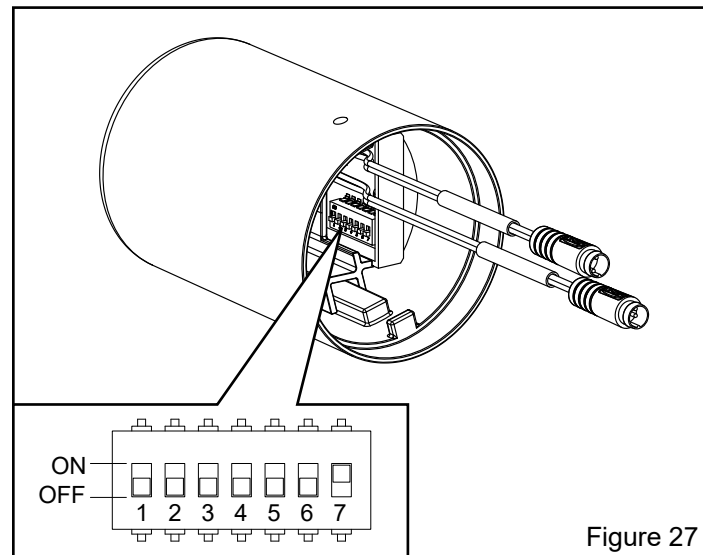

Figure 27

## Sensor Range Adjustment (when necessary)

### STEP 1.1

Place the Zurn Magic Magnet (optional accessory: P6900-AT-MAG) against the cap at the lower right corner of the Zurn logo under the sensor lens. Hold in place until the valve automatically flushes and the red LED light flashes two (2) times. Remove Magic Magnet from flush valve. The valve has entered calibrate mode.

### STEP 1.2

Place light-colored target at desired detection range away from sensor. After 10 more LED flashes followed by a double flash and/or flush the new detection range will be calibrated and set.

**⚠** Test new calibrated sensor range using targets of various material types/textures to ensure calibration accuracy. Verify that sensor range does not detect stall doors or other reflective surfaces.

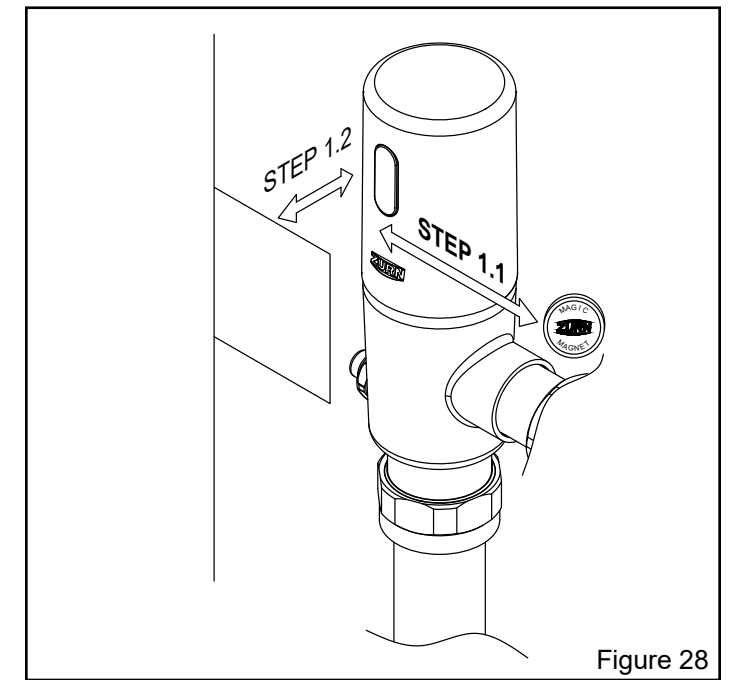

Figure 28

## Care and Cleaning Instruction

- Do not use any abrasive or chemical cleaners to clean the flushometer.
- **ONLY** use warm water with mild soap. Wipe the device dry with a clean/soft towel or cloth.
- Be sure sensor lenses are protected from other cleaning chemicals or solvents to prevent potential damage.

### Accessing Piston Kit

- 1.) Turn off water supply and press manual override button to relieve all water pressure.
- 2.) Remove valve cap by loosening side set screws and lifting off cap. Or on a Vandel Resistant cap, loosen one set screw with 3/32" hex wrench and twist the cap off by turning clockwise.
- 3.) Using the M3 Allen Wrench, remove 6 hex screws on the standard cap. On the Vandel Resistant cap, remove the 4 exposed screws and the ring insert, followed by the remaining 2 screws. and the solenoid flange. See Figures 17-20, and 26 in Step 6.
- 4.) Remove the piston kit from the valve body by lifting the solenoid nut upward - not the wire. It may hesitate due to water vacuum or come out attached to the flange kit. Separate by pulling Piston Body from Solenoid Flange.

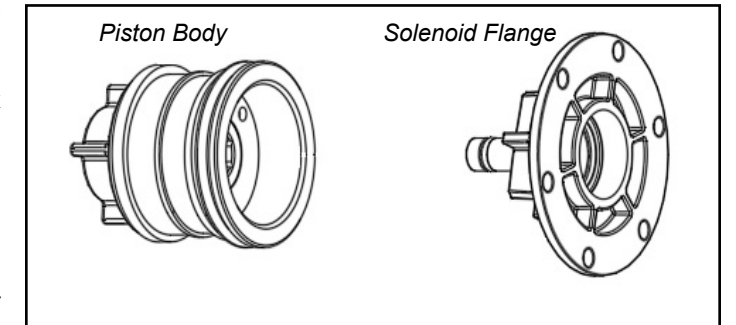

### Cleaning and Inspecting

- 1.) Inspect for damage to the seals or debris in the orifice. Excessive build up of debris may occur on filter screen.
- 2.) Clean the cup seal and face seal by wiping them with a soft cloth or rinse under water being careful not to damage the seals.
- 3.) Check the filter screen for debris buildup. Clean with a cloth or rinse under water or use light air pressure. Do not use sharp or abrasive tools.
- 4.) Check the orifice in the cup of the Piston Body, there are two round indentations, but only the orifice has a thru hole. Use a flashlight to shine light through the hole to confirm it is clear of debris.

**⚠ DO NOT ENLARGE THE ORIFICE WITH AGGRESSIVE CLEANING. PERMANENT DAMAGE MAY RESULT**

- 5.) If the orifice is blocked, a 26 AWG wire can be used as a cleaning tool. Carefully push the wire into the orifice until it stops; pull directly out to restore water flow. Do not attempt to use anything else, otherwise a "short flush" may result.
- 6.) Clean the exterior of the Solenoid body and the seals. Disassembly of the solenoid is not recommend for a novice. Call Zurn Customer Care for assistance.
- 7.) Reassemble and test by blocking sensor for 10 seconds and removing for a flush. Call Zurn Customer Care if it fails to operate.

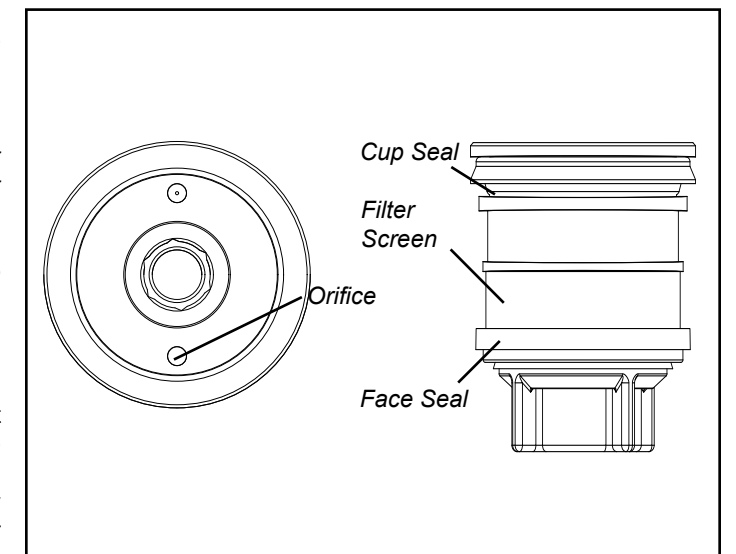

## TROUBLE SHOOTING GUIDE

PROBLEM	INDICATOR	POTENTIAL CAUSE	SOLUTION	
Valve does not flush	No lights on sensor board	Batteries not making contact	Remove and reinstall batteries correctly	
		Batteries reversed polarity	- See step 5A for reference	
	Sensor flashes (red) every 10 seconds	Low battery voltage indication	Replace batteries - see Step 5A for reference	
		Sensor flashes (red) every 30 seconds	Continuous target detection of object within sensor range	#1 Inspect and clean lens #2 Identify and remove any target from sensor field #3 Reduce sensor range distance (see page 10 for Sensor Range Adjustment instructions).
	Batter power level too low to activate full flush - sensor board automatically shuts down to avoid open flush		Dirty sensor lens	Clean lens until free of debris
			Loose or damaged solenoid connection	Inspect connection between solenoid and sensor for proper insertion - step 4
	No target detected	Install environment may require adjustment of the sensor range from the factory settings	Re-calibrate sensor range - see Sensor Range Adjustment (Figure 28) page 10	
Valve does not shut off water (continuous flow)	Valve continuously flows, even after a normal target acquisition and flush sequence	Water pressure either too high or too low	Adjust water pressure to recommended range: 35 to 80 psi running water pressure	
		Piston and / or solenoid plugged or damaged	Remove Piston and / or Solenoid to examine for damage or plugging. Clean piston / solenoid orifice if plugged. Replace solenoid kit if solenoid diaphragm is damaged.	
	Look for LED (double blink) and listen for solenoid click	Low or no power allowing solenoid to move to open position but not enough power to return to closed position.	Replace batteries or restore power if hardwired.	
		MOB (mechanical override button) sticking in open position	Replace MOB.	
Valve flows low (short flushing)	Valve does not evacuate fixture	Tailpiece filter is clogged with debris	#1 Turn stop off #2 Remove valve from stop and fixture #3 Inspect/clean filter (see parts breakdown - Part number 10)	
		Piston orifice is enlarged	Replace piston	
		Flush valve rating does not match fixture flush rating	Replace flush valve to match fixture flush rating	
Ghost flushing	Flush valve activates without target present.	Highly reflective environment	Re-calibrate sensor range - see Sensor Range Adjustment	
		Sensor range set too far, picking up other objects.		
Continuous flushing	Valve flushes every 30 seconds.	Magnet stored in sensor cap.	Remove magnet from sensor cap. Do not store magnet in flush valve.	
Electronic Control Board	Cannot adjust sensor range	Processor latched	Reset electronics module by removing cap, disconnect power connector and shorting terminals together. Reconnect power, allowing 30 seconds to complete power up sequence.	
	DIP switch settings	Configuration changes to DIP switches	Remove cap from valve and disconnect power. Move DIP switch to desired position. Reconnect power, allowing 30 seconds to complete power up sequence.	

For further assistance with troubleshooting, visit <http://www.zurn.com/>

## ZTR6200 Series Parts Breakdown (Plastic Cap)

### Parts Identification

- Cover screw
- Valve Cap/Sensor Assembly
- Solenoid
- Piston Cover Screws
- Solenoid Kit
- Flange O-rings
- Piston Kit
- Valve Housing
- Manual Override Button
- Filter
- Valve Assembly
- Vacuum Breaker
- Vacuum Breaker Tube
- Vacuum Breaker Tube Nut
- Spud Nut
- Spud Friction Washer
- Spud Sleeve
- Spud Escutcheon
- Setscrew for Control Stop Cover
- Vandal-Resistant Control Stop Cover
- Stop Cap Bonnet
- Stop Internals
- Piston Seal
- Stop Body
- Sweat Solder Adapter
- Supply Cover Tube
- Setscrew for Cast Wall Escutcheon
- Cast Wall Escutcheon
- Hex Wrench
- Top Valve Cap/Sensor Assembly
- Battery Housing
- Hardwired Top Valve Cap/Sensor Assembly
- Wire Supply Tube and Escutcheon

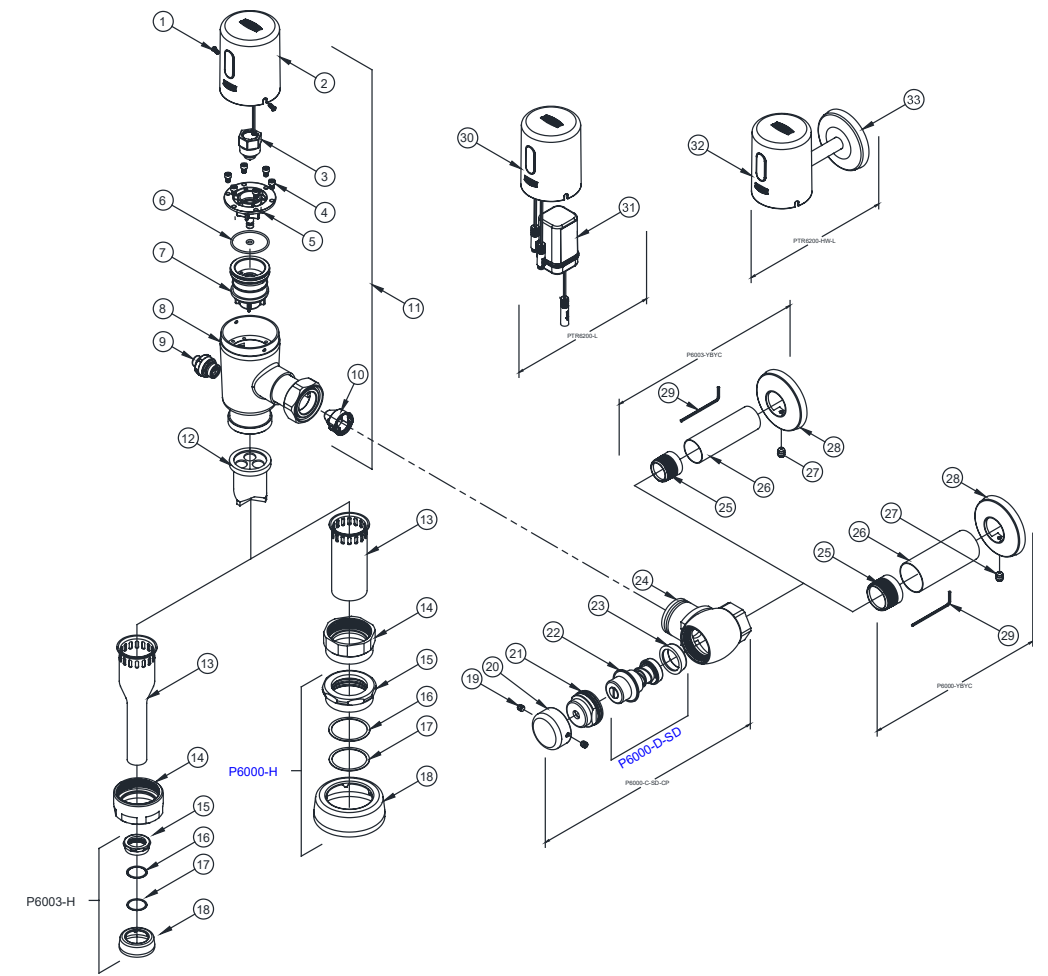

Battery Cap	Product No.
Valve Cap, (1.1 gpf), Item 2	PTR6200-L-1.1
Valve Cap, (1.28 gpf), Item 2	PTR6200-L-1.28
Valve Cap, (1.6 gpf), Item 2	PTR6200-L-1.6
Valve Cap, (1.0 gpf), Item 2	PTR6200-L-1.0
Valve Cap, (0.5 gpf), Item 2	PTR6200-L-0.5
Valve Cap, (0.25 gpf), Item 2	PTR6200-L-0.25
Valve Cap, (0.125 gpf), Item 2	PTR6200-L-0.125

Valve and Components	Product No.
Valve Housing, Items 8 & 9	PTR6200-HSA
Solenoid Replacement Kit, Item 3-5	PTR6200-M
Piston Kit (1.1/1.28/1.6 GPF), Item 7	PTR6200-EC
Piston Kit (0.5/1.0 GPF), Item 7	PTR6203-EU
Piston Kit (0.125/0.25 GPF), Item 7	PTR6203-EU-ULF
Manual Override Button Assy, Item 9	PTR6200-24
Flange O-Ring, Item 6	PTR6200-M-RING
Flange Screws, Item 4	PTR6200-M-S
Filter, (1.28/1.6 gpf), Item 10	P6000-FA
Filter, (1.0/0.5 gpf), Item 10	PTR6203-FA
Sealed Battery Housing, Item 31	PTR6200-BATT

Hardwired Cap	Product No.
Valve Cap, (1.1 gpf), Item 32	PTR6200-HW-L-1.1
Valve Cap, (1.28 gpf), Item 32	PTR6200-HW-L-1.28
Valve Cap, (1.6 gpf), Item 32	PTR6200-HW-L-1.6
Valve Cap, (1.0 gpf), Item 32	PTR6200-HW-L-1.0
Valve Cap, (0.5 gpf), Item 32	PTR6200-HW-L-0.5
Valve Cap, (0.25 gpf), Item 32	PTR6200-HW-L-0.25
Valve Cap, (0.125 gpf), Item 32	PTR6200-HW-L-0.125

Flush Connections and Spud Coupling Kits	Product No.
Flush Connection and Spud Coupling, Items 15-18	P6000-H P6003-H
Vacuum Breaker Repair Kit, Items 12	P6000-B-HP P6003-B-HP
Vacuum Breaker Tube, Item 13	P6000-A-CP
Vacuum Breaker Tube Nut, Item 14	P6000-AA-CP

Control Stop Repair Kit and Parts	Product No.
Control Stop Repair Kit for 1" and 3/4", Includes Items 14-20	P6000-C-SD-CP
Seal Seat for 1" and 3/4", Includes Item 23	P6000-D42
Sweat Solder Adapter, Includes Item 25	P6000-YBA
Vandal resistant control stop cover Items 19-20	P6000-VC
Sweat solder kit, Items 25-29	P6000-YBYC P6003-YBYC

# ZTR6200 Series Parts Breakdown (Metal Cap)

## Parts Identification

1. Ring Insert Assembly
2. Valve Cap/Sensor Assembly
3. Solenoid
4. Piston Cover Screws
5. Solenoid Kit
6. Flange O-rings
7. Piston Kit
8. Valve Housing
9. Manual Override Button
10. Filter
11. Valve Assembly
12. Vacuum Breaker
13. Vacuum Breaker Tube
14. Vacuum Breaker Tube Nut
15. Spud Nut
16. Spud Friction Washer
17. Spud Sleeve
18. Spud Escutcheon
19. Setscrew for Control Stop Cover
20. Vandal-Resistant Control Stop Cover
21. Stop Cap Bonnet
22. Stop Internals
23. Piston Seal
24. Stop Body
25. Sweat Solder Adapter
26. Supply Cover Tube
27. Setscrew for Cast Wall Escutcheon
28. Cast Wall Escutcheon
29. Hex Wrench
30. Vandal Resistant Top Valve Cap/Sensor Assembly
31. Battery Housing
32. Vandal Resistant Hardwired Top Valve Cap/Sensor Assembly
33. Wire Supply Tube and Escutcheon

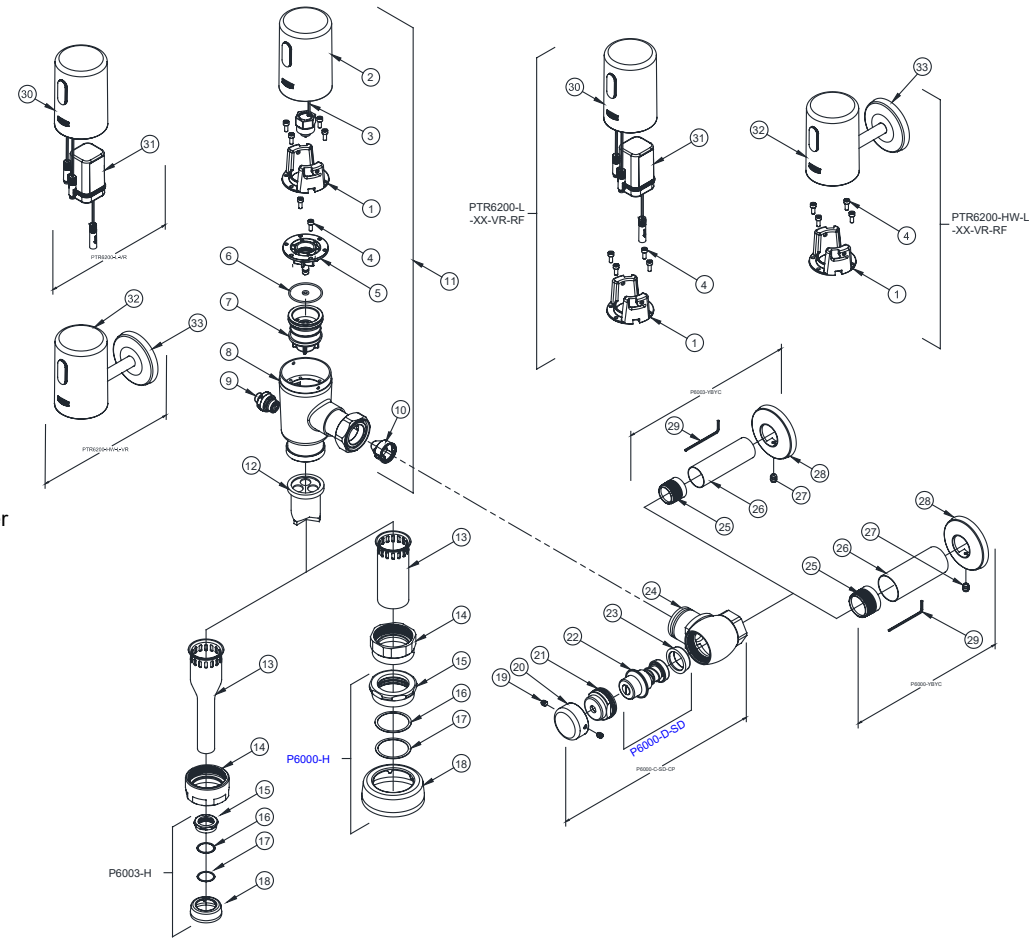

This Page Intentionally Left Blank

Battery Cap	Product No.
Metal Valve Cap, (1.1 gpf), Item 2	PTR6200-L-1.1-VR
Metal Valve Cap, (1.28 gpf), Item 2	PTR6200-L-1.28-VR
Metal Valve Cap, (1.6 gpf), Item 2	PTR6200-L-1.6-VR
Metal Valve Cap, (1.0 gpf), Item 2	PTR6200-L-1.0-VR
Metal Valve Cap, (0.5 gpf), Item 2	PTR6200-L-0.5-VR
Metal Valve Cap, (0.25 gpf), Item 2	PTR6200-L-0.25-VR
Metal Valve Cap, (0.125 gpf), Item 2	PTR6200-L-0.125-VR
Metal Valve Cap Retrofit Kit, Item 1, 4, 30 & 31	PTR6200-L-XX-VR-RF
Metal Valve Cap, (1.6/1.1 gpf), Item 2	PTR6200-L-WS1-DF-VR

Hardwired Cap	Product No.
Metal Valve Cap, (1.1 gpf), Item 32	PTR6200-HW-L-1.1-VR
Metal Valve Cap, (1.28 gpf), Item 32	PTR6200-HW-L-1.28-VR
Metal Valve Cap, (1.6 gpf), Item 32	PTR6200-HW-L-1.6-VR
Metal Valve Cap, (1.0 gpf), Item 32	PTR6200-HW-L-1.0-VR
Metal Valve Cap, (0.5 gpf), Item 32	PTR6200-HW-L-0.5-VR
Metal Valve Cap, (0.25 gpf), Item 32	PTR6200-HW-L-0.25-VR
Metal Valve Cap, (0.125 gpf), Item 32	PTR6200-HW-L-0.125-VR
Metal Valve Cap Retrofit Kit, Item 1, 4, 32 & 33	PTR6200-HW-L-XX-VR-RF
Metal Valve Cap, (1.6/1.1 gpf), Item 32	PTR6200-HW-L-WS1-DF-VR

Valve and Components	Product No.
Valve Housing, Items 8 & 9	PTR6200-HSA
Solenoid Replacement Kit for Valves with Metal Caps, Item 3-5	PTR6200-M
Piston Kit (1.1/1.28/1.6 GPF), Item 7	PTR6200-EC
Piston Kit (0.5/1.0 GPF), Item 7	PTR6203-EU
Piston Kit (0.125/0.25 GPF), Item 7	PTR6203-EU-ULF
Manual Override Button Assy, Item 9	<a href="#">PTR6200-24</a>
Flange O-Ring, Item 6	PTR6200-M-RING
Flange Screws for Valves with Metal Caps, Item 4	PTR6200-M-S-VR
Filter, (1.1/1.28/1.6 gpf), Item 10	P6000-FA
Filter, (1.0/0.5 gpf), Item 10	PTR6203-FA
Filter, (0.25/0.125 gpf), Item 10	PTR6203-FA-LF
Sealed Battery Housing, Item 31	PTR6200-BATT

Flush Connections and Spud Coupling Kits	Product No.
Flush Connection and Spud Coupling, Items 15-18	<a href="#">P6000-H</a> P6003-H
Vacuum Breaker Repair Kit, Items 12	<a href="#">P6000-B-HP</a> P6003-B-HP
Vacuum Breaker Tube, Item 13	P6000-A-CP
Vacuum Breaker Tube Nut, Item 14	P6000-AA-CP

Control Stop Repair Kit and Parts	Product No.
Control Stop Repair Kit for 1" and 3/4", Includes Items 14-20	P6000-C-SD-CP
Seal Seat for 1" and 3/4", Includes Item 23	P6000-D42
Sweat Solder Adapter, Includes Item 25	P6000-YBA
Vandal resistant control stop cover Items 19-20	P6000-VC
Sweat solder kit, Items 25-29	P6000-YBYC P6003-YBYC

Rev. AE | Date: 5/15/25 | C.N. No. 146884 | Prod./Dwg. No. FV541

---

Patent [zurn.com/patents](http://zurn.com/patents)

US 1.855.0NE.ZURN CANADA 1.877.892.5216

**ZURN.COM**

by **zurn ELKAY** Water Solutions