

**ZURN** *Linear Drainage*

*ZF806 · ZF812*  
*Fiberglass Trench*



**Installation Instructions**

---

## ZF806 Accessories 6" [152mm] Wide Fiberglass Trench Drain System

Below are some of the ZF806 trench drain components typical to an installation. Double check your order to ensure that you have all components particular to your job before beginning your installation.

Contact Zurn at 855-ONE-ZURN (855-663-9876) should additional material be required.

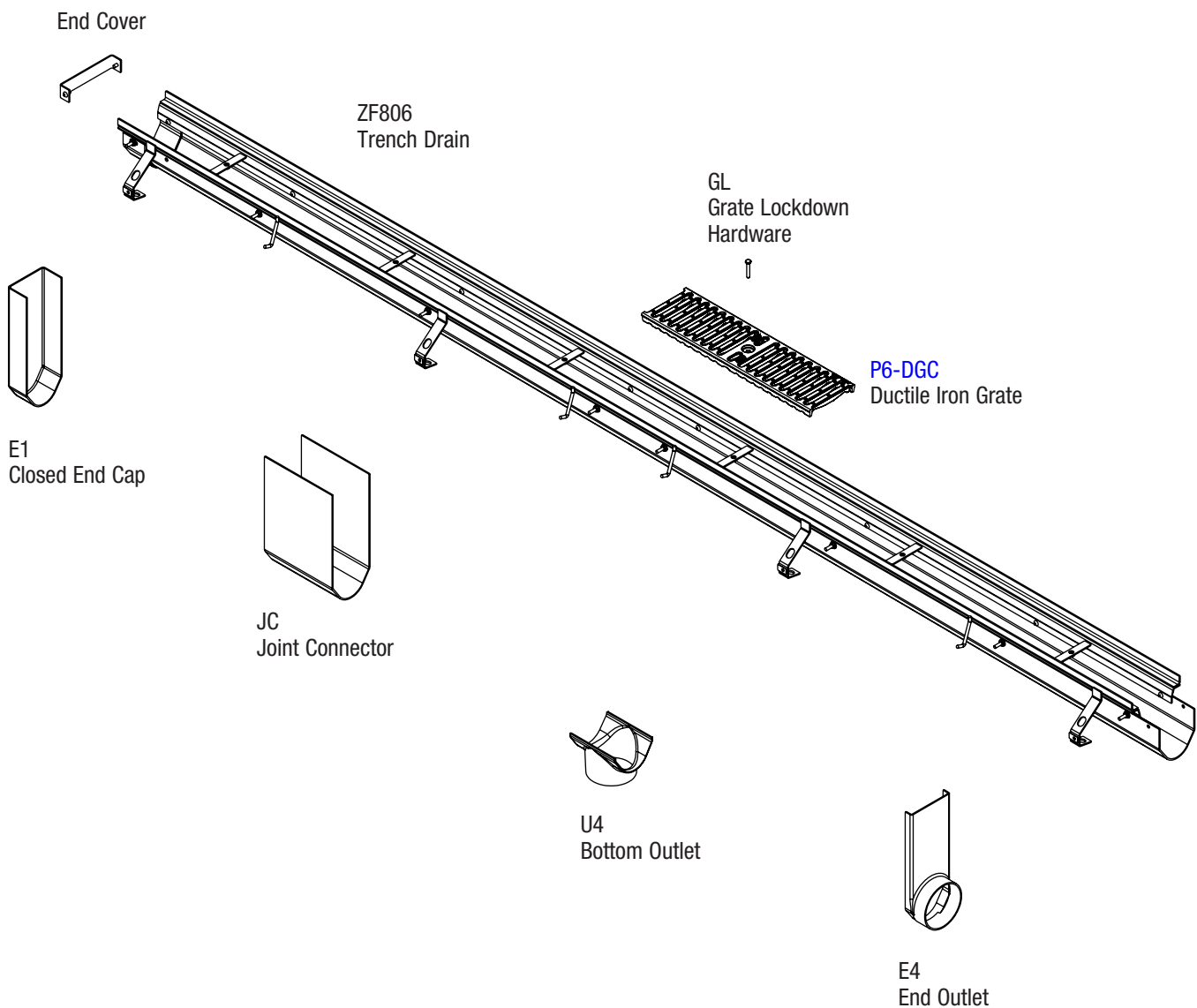

## ZF812 Accessories 12" [304mm] Wide Fiberglass Trench Drain System

Below are some of the ZF812 trench drain components typical to an installation. Double check your order to ensure that you have all components particular to your job before beginning your installation.

Contact Zurn at 855-ONE-ZURN (855-663-9876) should additional material be required.

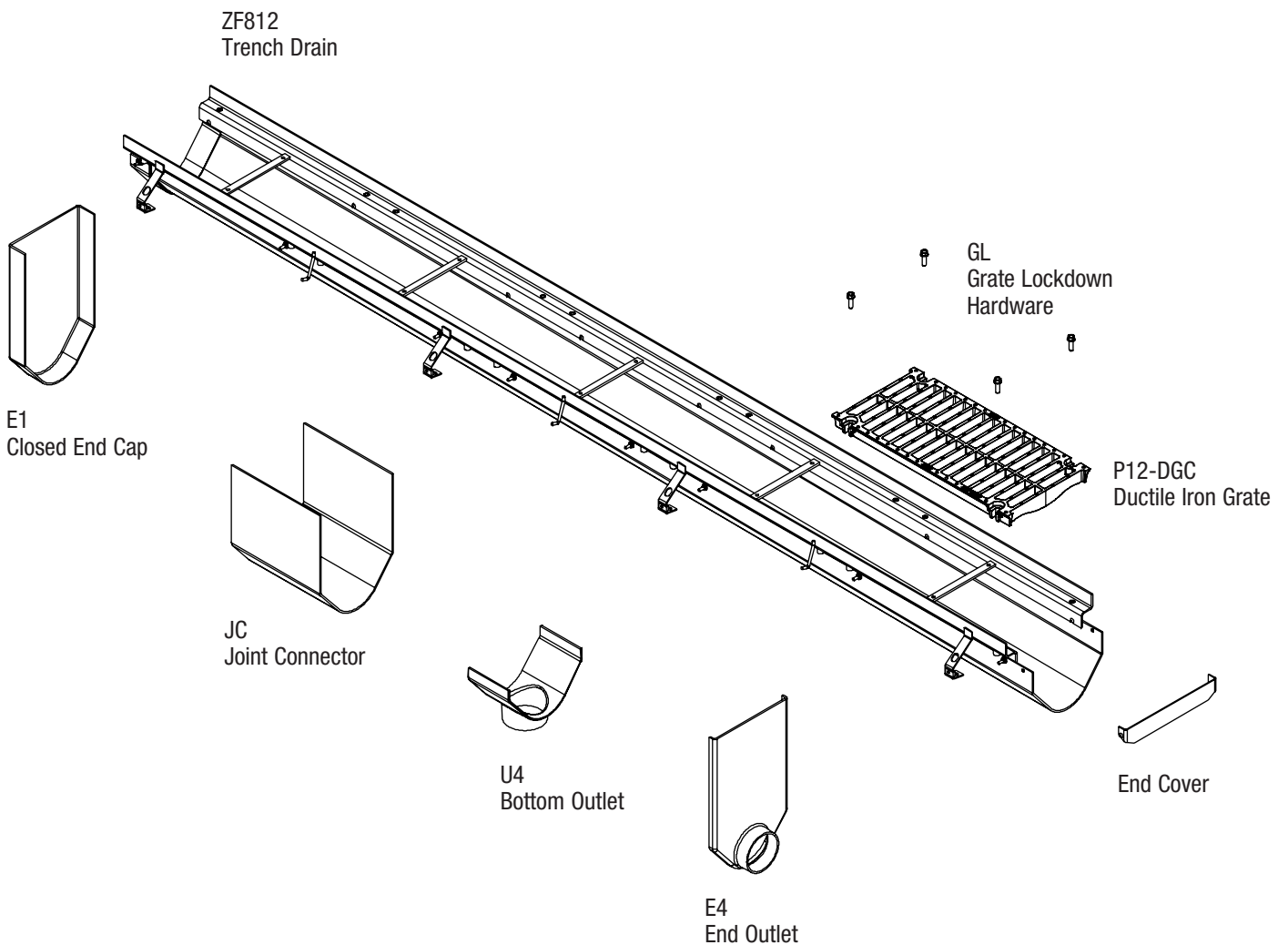

## ZF817 Accessories

Below are some of the ZF817 catch basin components typical to an installation. Double check your order to ensure that you have all components particular to your job before beginning your installation.

Contact Zurn at 855-ONE-ZURN (855-663-9876) should additional material be required.

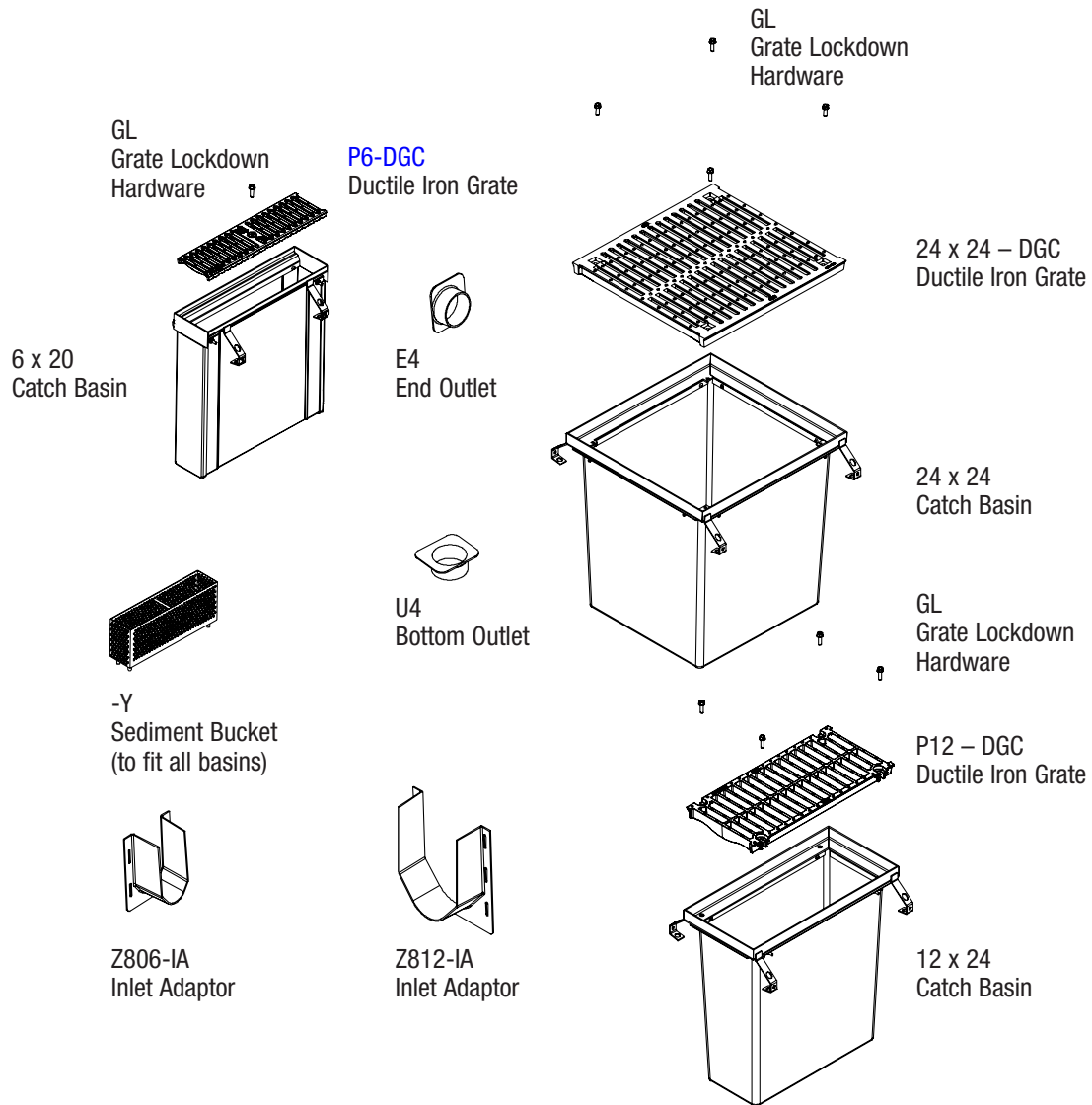

## Encasement

Regardless of how light the load carrying capacity is intended to be, 4 inch concrete encasement is a minimum. Always consult local codes and the specifying engineer for concrete encasement dimensions and reinforcement requirements for your specific job. Guidelines for reinforcing and encasement would be to use the same thickness and reinforcing used in the surrounding concrete slab. Concrete must be vibrated to remove air voids in encasement, especially under the frame rails.

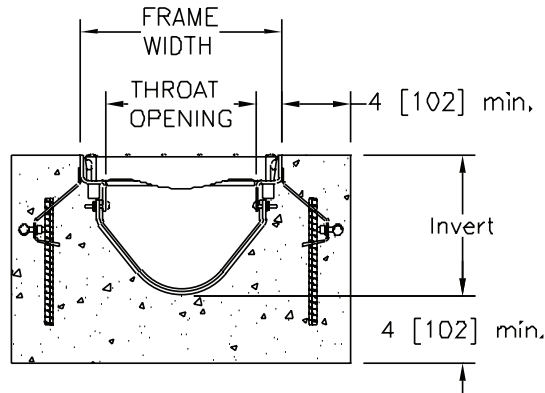

## Excavation

Trench excavation must include the minimum of 4 inches, or the slab thickness, surrounding the trench on both sides and underneath. Soft and/or shifting soil substrates may cause cracking of the concrete and consequent movement of the trench. It is critical that the concrete be poured on an adequate foundation. Verify depth of trench excavation to allow for the same thickness of concrete as the surrounding slab thickness, under and beside the trench.

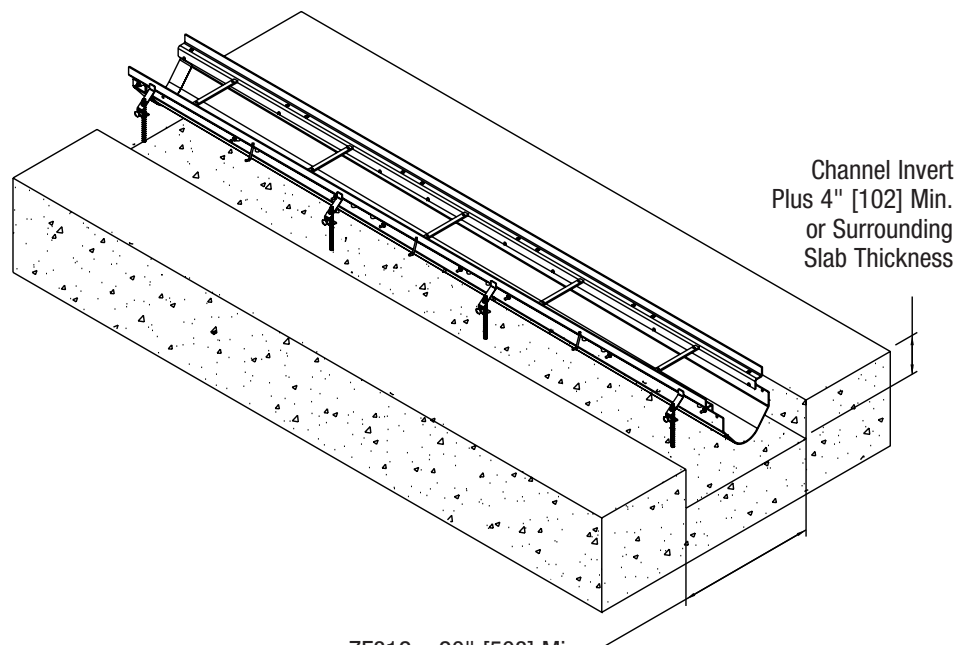

ZF812 – 20" [508] Min.  
12" [305] + Twice Surrounding  
Slab Thickness

ZF806 – 14" [356] Min.  
6" [152] + Twice Surrounding  
Slab Thickness

## Job Layout

Upon completion of the excavation, the channel should be placed in numeric order alongside the excavation and according to the job layout. Each trench section has a trench identification number and flow direction arrow indicating its sequence within the system. It is easier to work from the deep end to the shallow end. Grates are not installed at this time.

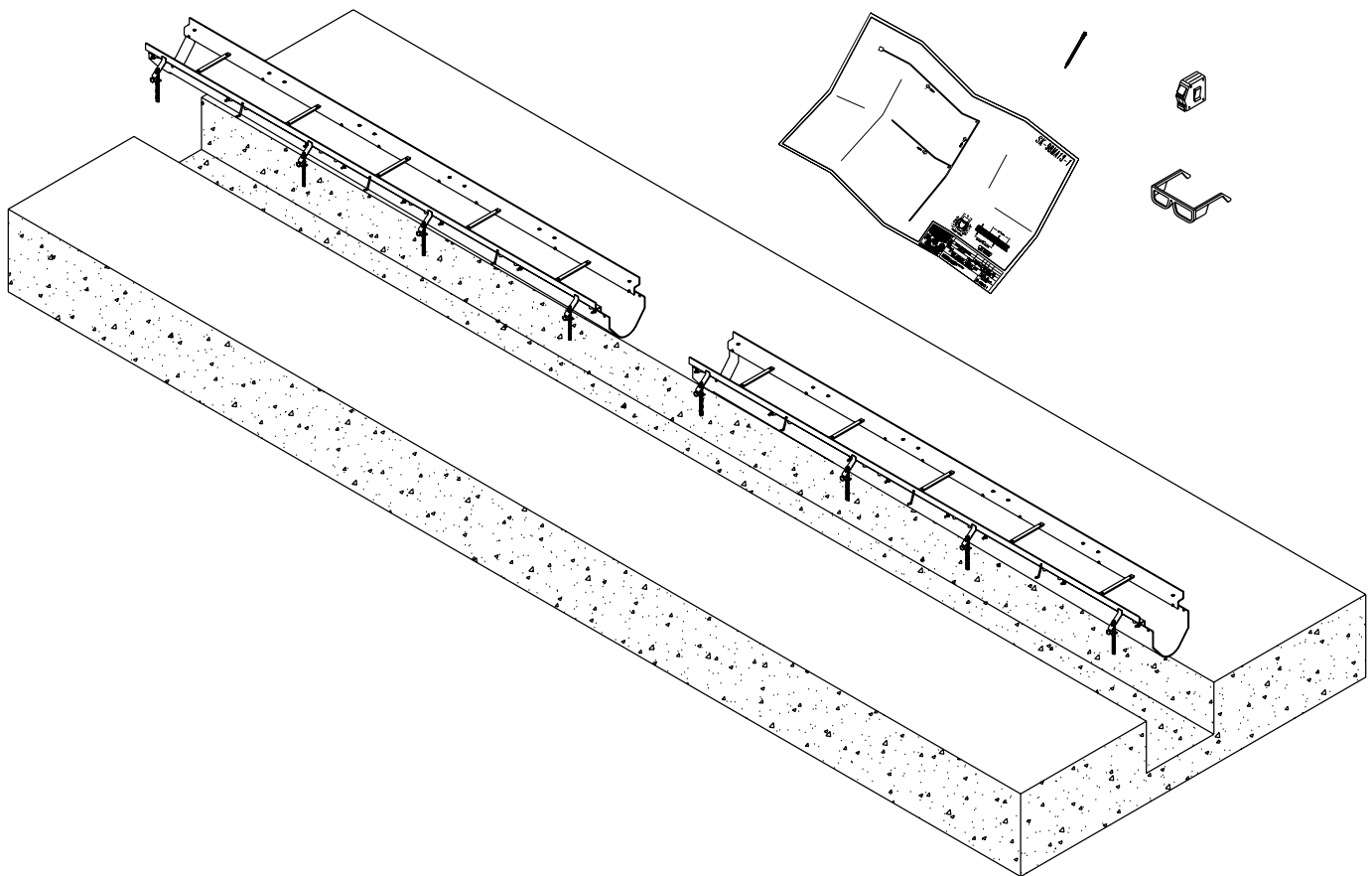

## Connecting Frame to Channel

When connecting frame to channel, be sure the heads of the screws are inside the throat of the channel.

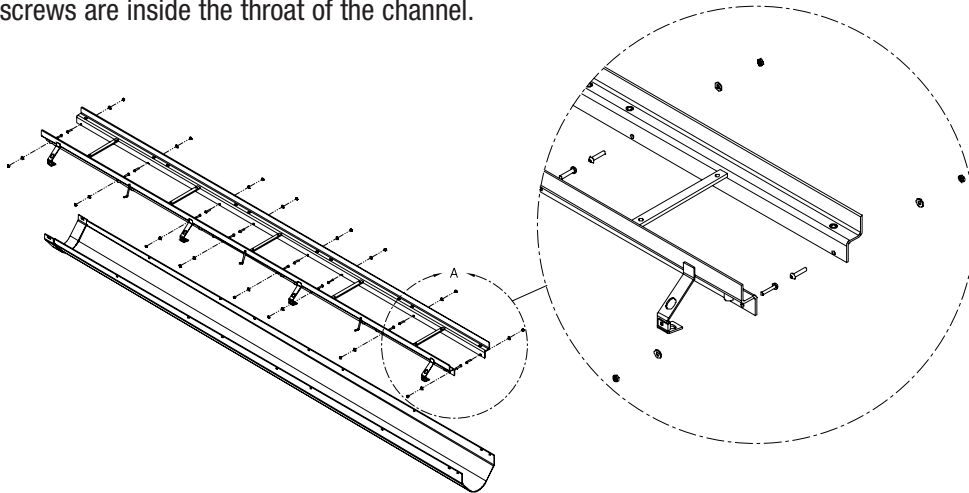

## Connecting Channel to Sidewall, and Sidewall to Frame

When connecting channel to sidewall, be sure:

1. Flange of sidewall is not in throat of channel.
2. Bell end of sidewall aligns with bell end of channel.
3. Heads of the screws are inside the throat of channel.

When connecting sidewall to frame, be sure the heads of the screws are inside the throat of the channel.

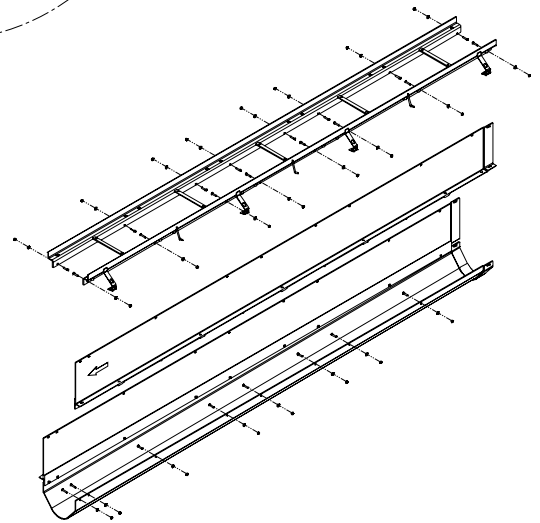

## Connecting Channel to Channel

Channels should be installed from deep to shallow. This allows the next shallower channel's male connection to easily slide into the previous channel's bell. Slide in place and attach with the provided connection hardware.

### Sealing:

- Channel connections are designed to be a good seal. Concrete aggregate shall not intrude into the trench.
- Silicone sealant or concrete adhesive may be used as a gasket between the channels for a better seal.

### Connections:

Minimum overlap of 3/4" is acceptable in the overlap connection, frames shall be flush.

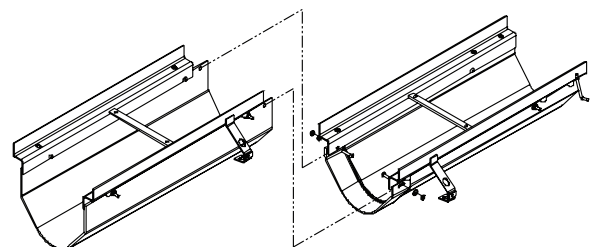

## End Outlet Options

### Step 1

When installing end cap or end outlet, cut the channel connection (if needed) so the channel is flush with the end of the frame.

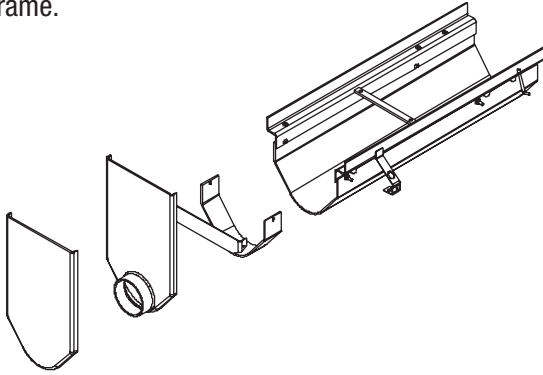

### Step 2

Attach the frame end plate with screws.

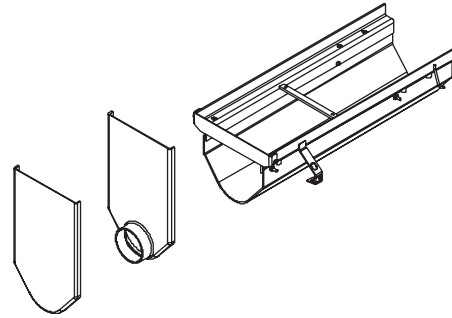

### Step 3

Cut end outlet or end cap excess height to just below the frame end plate.

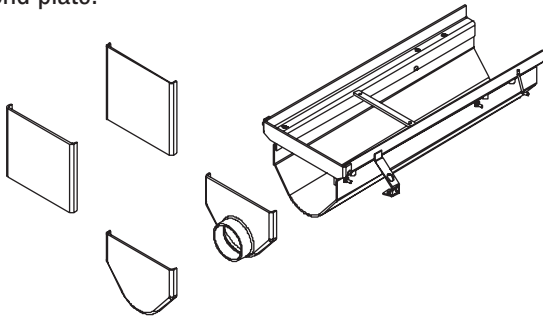

### Step 4

Attach end outlet or end cap with silicone caulk or construction adhesive.

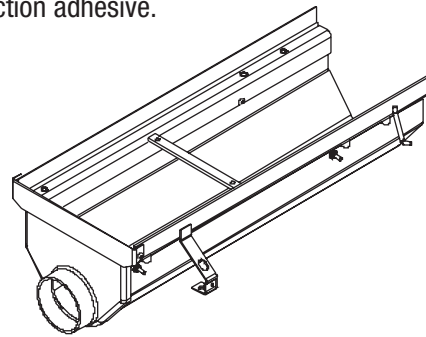

Make sure all overlaps on trench are trimmed off prior to installing the end caps to ensure the finish installation has a frame above the trench channel. This ensures each trench will have a grate on it.

## Bottom Outlet Options

A bottom outlet is attached to the bottom of the trench drain with silicone caulk or construction adhesive as shown below. A hole saw can be used to cut the appropriate size hole through the bottom of the trench.

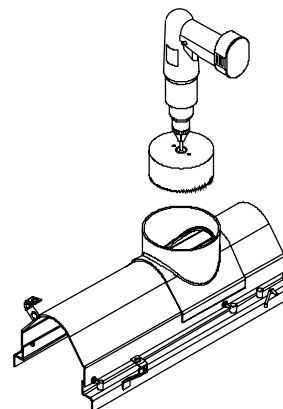
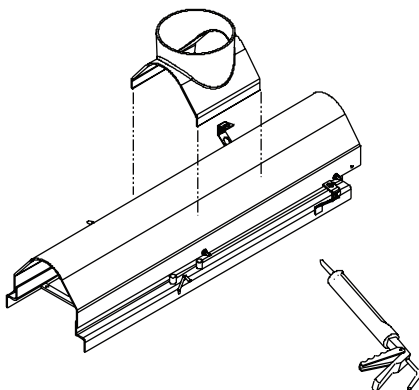

## Female to Female Connection

When job layout calls for female to female channel connection, contact engineering at 855-ONE-ZURN (855-663-9876).

## Joint Connection

A joint connector (JC) is available for both the ZF806 and the ZF812 to join two trench sections without the interlocking joint, such as sections that may be flowing in opposite

directions. Cut the lengths and place the JC as shown, using silicone caulk or a construction adhesive as sealant.

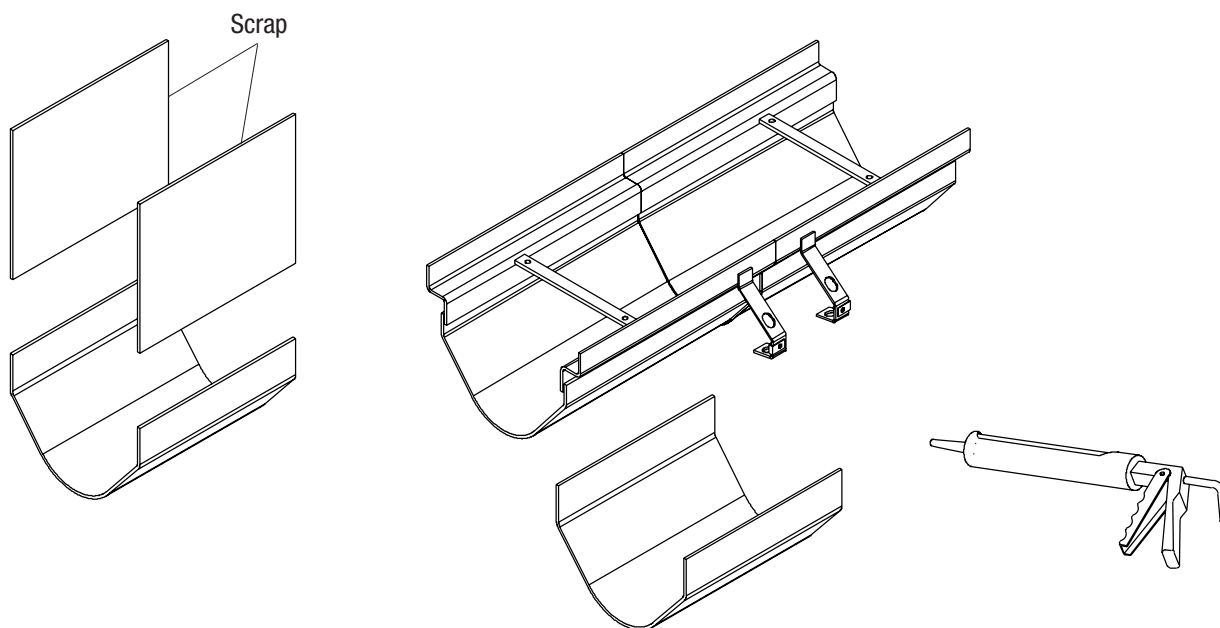

## Catch Basins 6" x 20"

### Step 1

To make a catch basin connection, simply invert the catch basin and channel, and trace the outline of the channel onto the basin. Cutting the hole in the basin is easily accomplished using a hand saw or power reciprocating saw. Cut out all material inside of the traced area. **Do not cut the frame.**

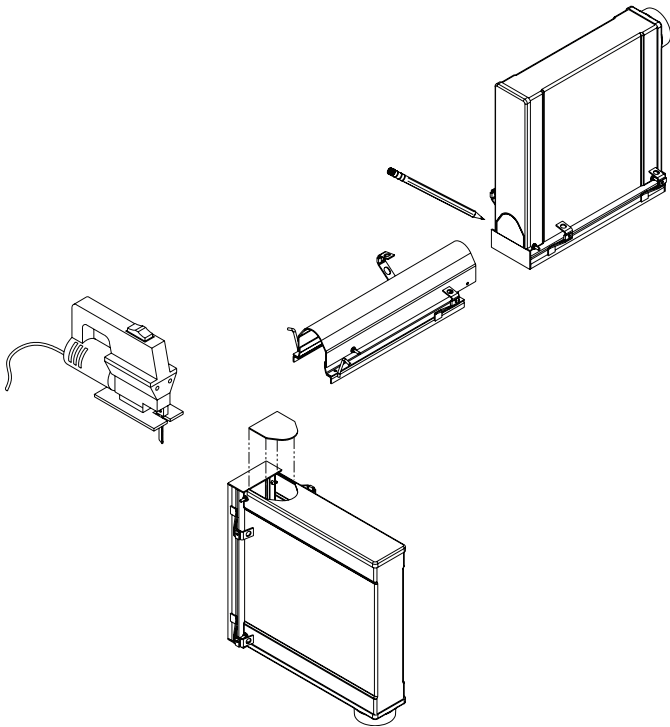

### Step 2

After the channel outline is removed from the catch basin, slide the male end of the channel into the basin underneath the frame and secure it with the hardware provided. After the connection is complete and the channel leveled, a silicone caulk or a construction adhesive is recommended around the connection.

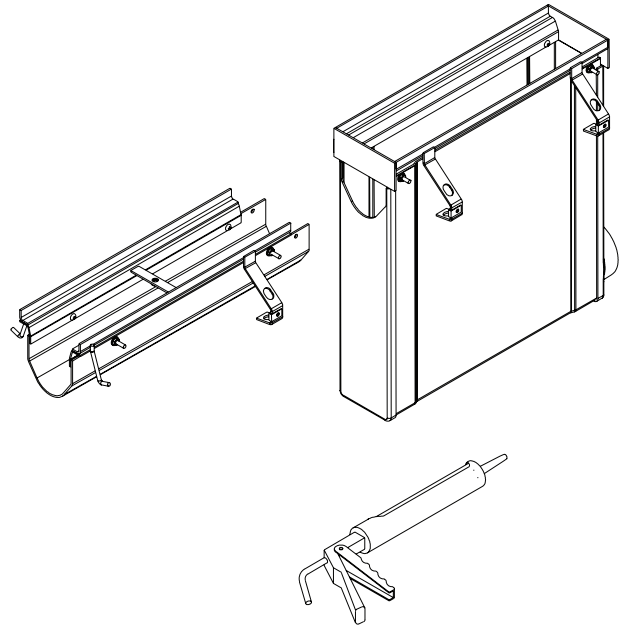

## Catch Basins 12" x 24"

### ZF806 to 12" x 24", or 24" x 24"

#### Step 1

Invert the catch basin and channel and trace the outline of the outside of the channel onto the basin. Cut the hole in the basin with a hand saw or power reciprocating saw. Remove all material inside of traced area.

**Do not cut the frame.**

#### Step 2

Temporarily insert the channel into the hole cut in the basin. Observe the interference between the channel and the basin frame. Cut notches into the channel to allow the channel frame to butt against the basin frame.

#### Step 3

Butt channel frame against basin frame. Trace a line on the channel indicating the profile of the hole in the catch basin. Cut channel so that the end of the channel is flush with the inside surface of the catch basin.

#### Step 4

Cut the inlet adaptor such that: 1) the interior profile of the inlet adaptor matches the profile of the hole in the basin and, 2) the height of the inlet adaptor matches the height of the hole in the basin.

#### Step 5

Temporarily insert the channel into the basin again. Attempt to attach the inlet adaptor to the basin and channel. Notice the possible interference between the inlet adaptor and a bolt sticking out of the channel. Scribe lines on the inlet adaptor and cut notches in it that will allow the channel to slide into the inlet adaptor once the inlet adaptor is attached to the catch basin.

#### Step 6

Seal the inlet adaptor to the basin using silicone caulk or construction adhesive and fasten with the hardware provided. Slide the male end of the channel into the inlet adaptor, securing them together with silicone caulk or construction adhesive.

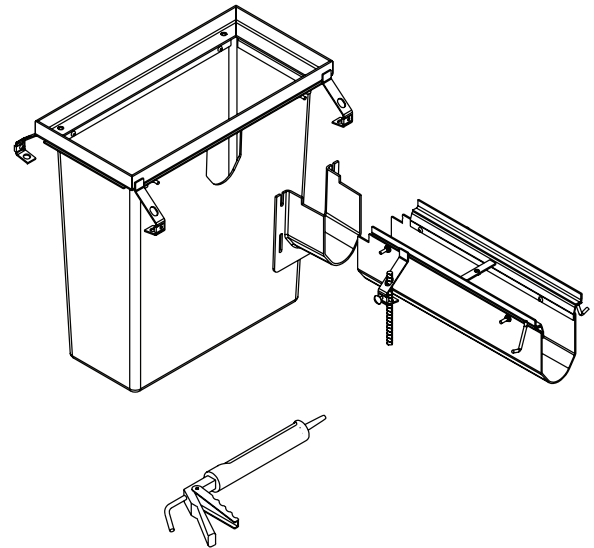

### ZF812 to 12" x 24", 24" Side

#### Step 1

Invert the catch basin and channel and trace the outline of the outside of the channel onto the basin. Cut the hole in the basin with a hand saw or power reciprocating saw. Remove all material inside of traced area.

**Do not cut the frame.**

#### Step 2

Temporarily insert channel into basin such that the channel frame butts against the basin frame. Trace a line on the channel indicating the profile of the hole in the catch basin. Cut channel so that the end of the channel is flush with the inside surface of the catch basin.

#### Step 3

Cut the inlet adaptor such that: 1) the interior profile of the inlet adaptor matches the profile of the hole in the basin and, 2) the cut surfaces of the inlet adaptor fit snugly against the bottom surface of the basin frame.

#### Step 4

Temporarily insert the channel into the basin again. Attempt to attach the inlet adaptor to the basin and channel. Notice the possible interference between the inlet adaptor and a boss on the channel frame. Scribe lines on the inlet adaptor and cut notches in it that will allow the channel to slide into the inlet adaptor once the inlet adaptor is attached to the catch basin.

#### Step 5

Seal the inlet adaptor to the basin using silicone caulk or construction adhesive and fasten with the hardware provided. Slide the male end of the channel into the inlet adaptor, securing them together with silicone caulk or construction adhesive.

### ZF812 to 12" x 24", 12" Side

Due to the fact that the width of the ZF812 is the same width as the 12" side of the 12" x 24" basin, this connection must be done in the factory. If this connection is needed, please send a sketch to Flo-Thru so a layout using our system can be done.

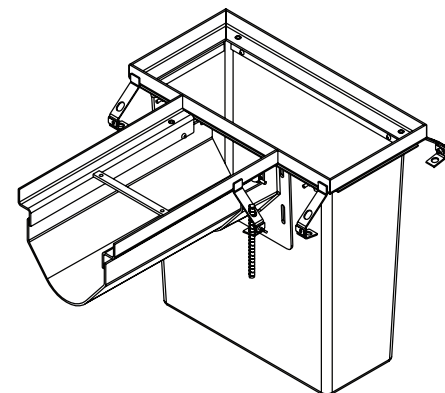
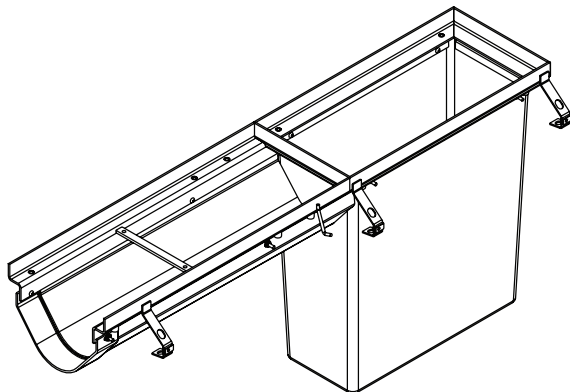

## Catch Basins 24" x 24"

### ZF812 to 24" x 24"

#### Step 1

Invert the catch basin and channel and trace the outline of the outside of the channel onto the basin. Cut the hole in the basin with a hand saw or power reciprocating saw. Remove all material inside of traced area. **Do not cut the frame.**

#### Step 2

Temporarily insert channel into basin such that the channel frame butts against the basin frame. Trace a line on the channel indicating the profile of the hole in the catch basin. Cut channel so that the end of the channel is flush with the inside surface of the catch basin.

#### Step 3

Cut the inlet adaptor such that: 1) the interior profile of the inlet adaptor matches the profile of the hole in the basin and, 2) the cut surfaces of the inlet adaptor fit snugly against the bottom surface of the basin frame.

#### Step 4

Temporarily insert the channel into the basin again. Attempt to attach the inlet adaptor to the basin and channel. Notice the possible interference between the inlet adaptor and a boss on the channel frame. Scribe lines on the inlet adaptor and cut notches in it that will allow the channel to slide into the inlet adaptor once the inlet adaptor is attached to the catch basin.

#### Step 5

Seal the inlet adaptor to the basin using silicone caulk or construction adhesive and fasten with the hardware provided. Slide the male end of the channel into the inlet adaptor, securing them together with silicone caulk or construction adhesive.

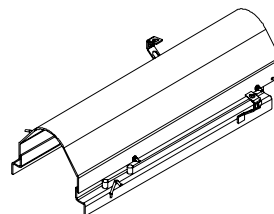
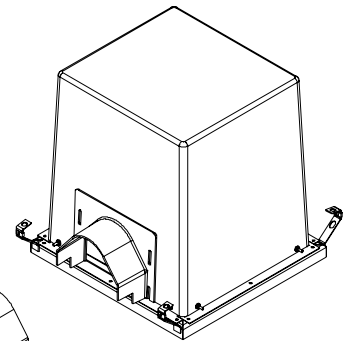
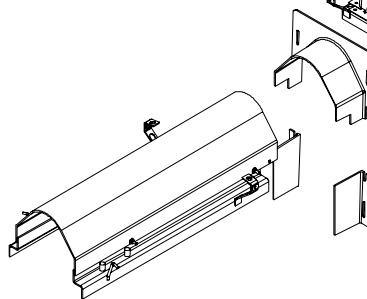
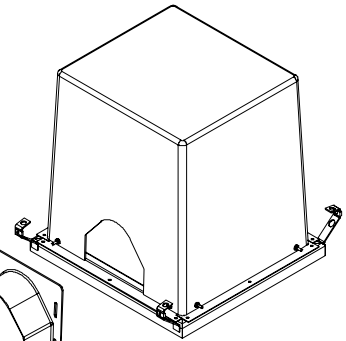
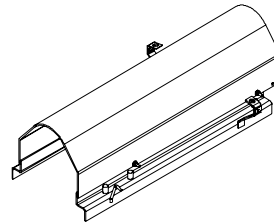
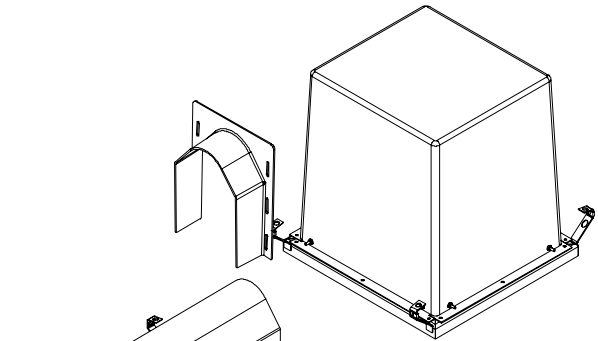

## Setting the Trench *New Construction*

Typically, a trench system is assembled from deep to shallow. Starting with the deepest section or catch basin, set the first channel utilizing the unique rebar anchoring system. Rebar is used on both sides of the length of each trench drain for easy attachment to #4 rebar stakes (use a minimum of 4 sets per 10' section of ZF806, a minimum of 4 sets per 10' section of ZF812). Simply attach the rebar to the anchor straps then drive the stakes into the ground. Adjust the trench to the desired elevation and secure the trench drain to the rebar stakes by tightening the screws against the rebar. Continue with the adjacent section. If a catch basin is included within your layout refer to CATCH BASIN INSTALLATION for further details on catch basin preparation.

### Setting The Trench

Set trench on rebar 1" above final grade, this allows final elevation adjustment with a hammer prior to pouring concrete.

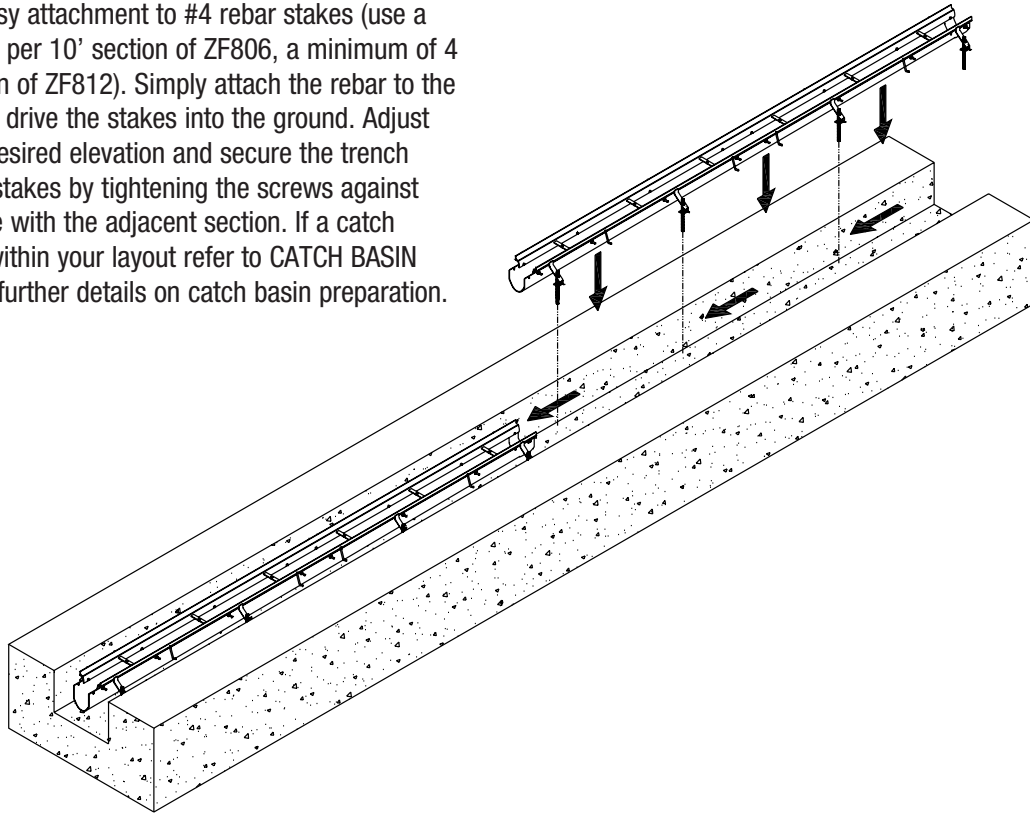

## Setting the Trench *Retrofit*

An alternative means of installation is to suspend the trench drain as shown. Wooden braces to hang the trench run can be attached to the drain body through the grate lock down bars as illustrated below.

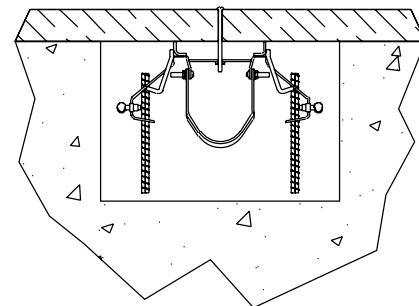
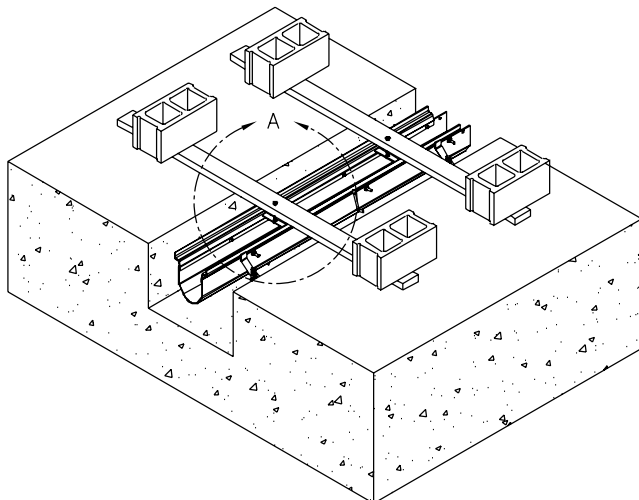

## Internal Bracing

### Channel Installation Without Sidewalls

Does not require internal bracing.

### ZF806 and ZF812 Channel Installation With Sidewalls

Once channel is assembled and in position, provide internal bracing underneath frame every 10" prior to concrete pour.

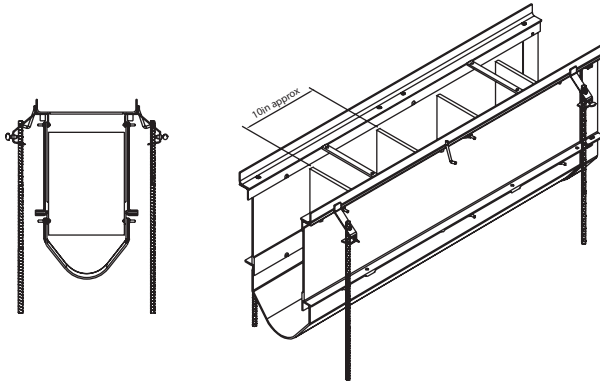

### ZF817 Catch Basin Installation

Provide internal bracing underneath frame prior to concrete pour.

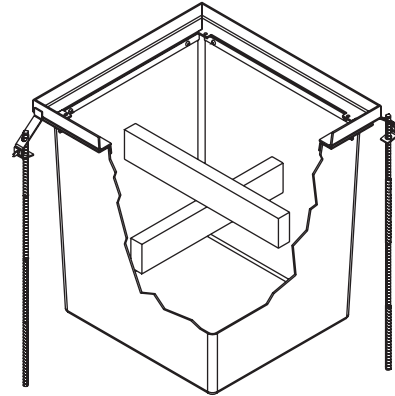

## Pouring the Concrete

Verify layout is correct prior to pouring concrete.

Pour the concrete around the three sides of the trench drain. Be certain to adequately VIBRATE the concrete as it is being poured. Proper vibration will eliminate any unwanted voids within the concrete pour.

If sidewalls are used, a first and second pour are recommended.

Finish troweling should be done to set the top edge of the trench drain about 1/16" below the floor grade. Remember to compensate for concrete shrink that may occur during cure so that the edge of the trench drain does not protrude above the finished floor grade.

### Placing Concrete

- Check that the trench drain is in the location required per the layout drawings prior to pouring concrete.
- Standard concrete practices with expansion and crack induction joints shall be followed based upon local codes and standards.
- The trench drain shall not be used as an expansion joint.
- Be sure to keep debris out of the lock down holes during concrete pour

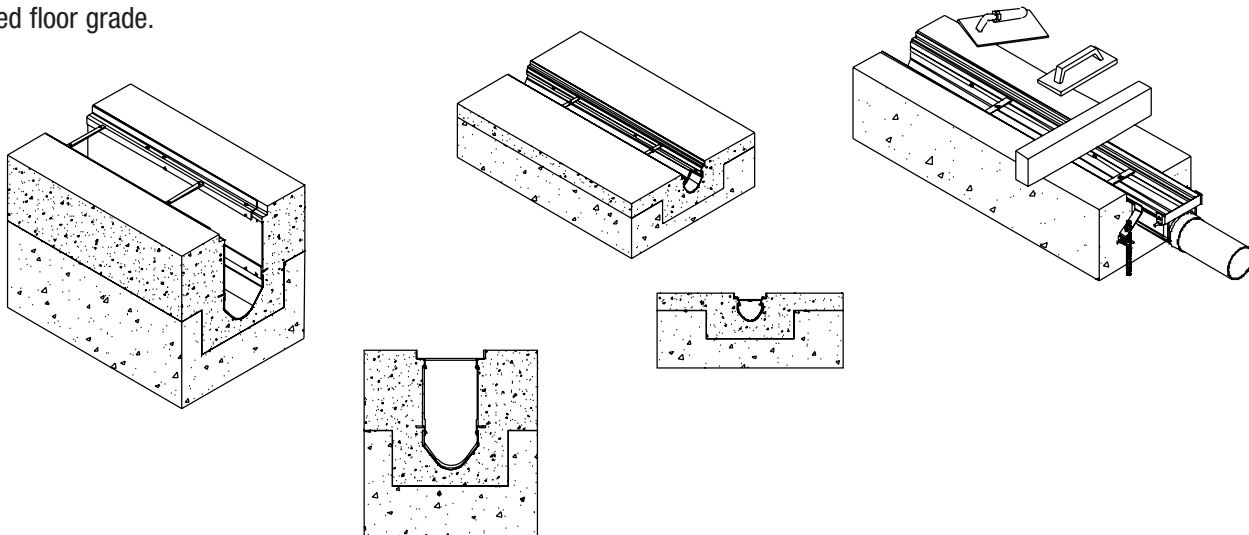

## Z886 Installing Grates

After the concrete has been poured, vibrated, and given sufficient time to dry, both the grates and grate lockdown bolts must be installed. For both the ZF806 and ZF812 the center of the grate should straddle the tie strap that spans the frame. The exception is when both channel and frames are cut. To place these grates, line up the lockdown hole in the grate with the lockdown hole in the frame. Grates with a length of under 12" for the ZF806 and 14" for the ZF812 will not be able to be locked down. Lockdown bolts can be installed using a 7/16" socket for the ZF806 and a 9/16" socket for the ZF812.

### Locking Down Grates

Start all bolts on each grate prior to tightening them down.

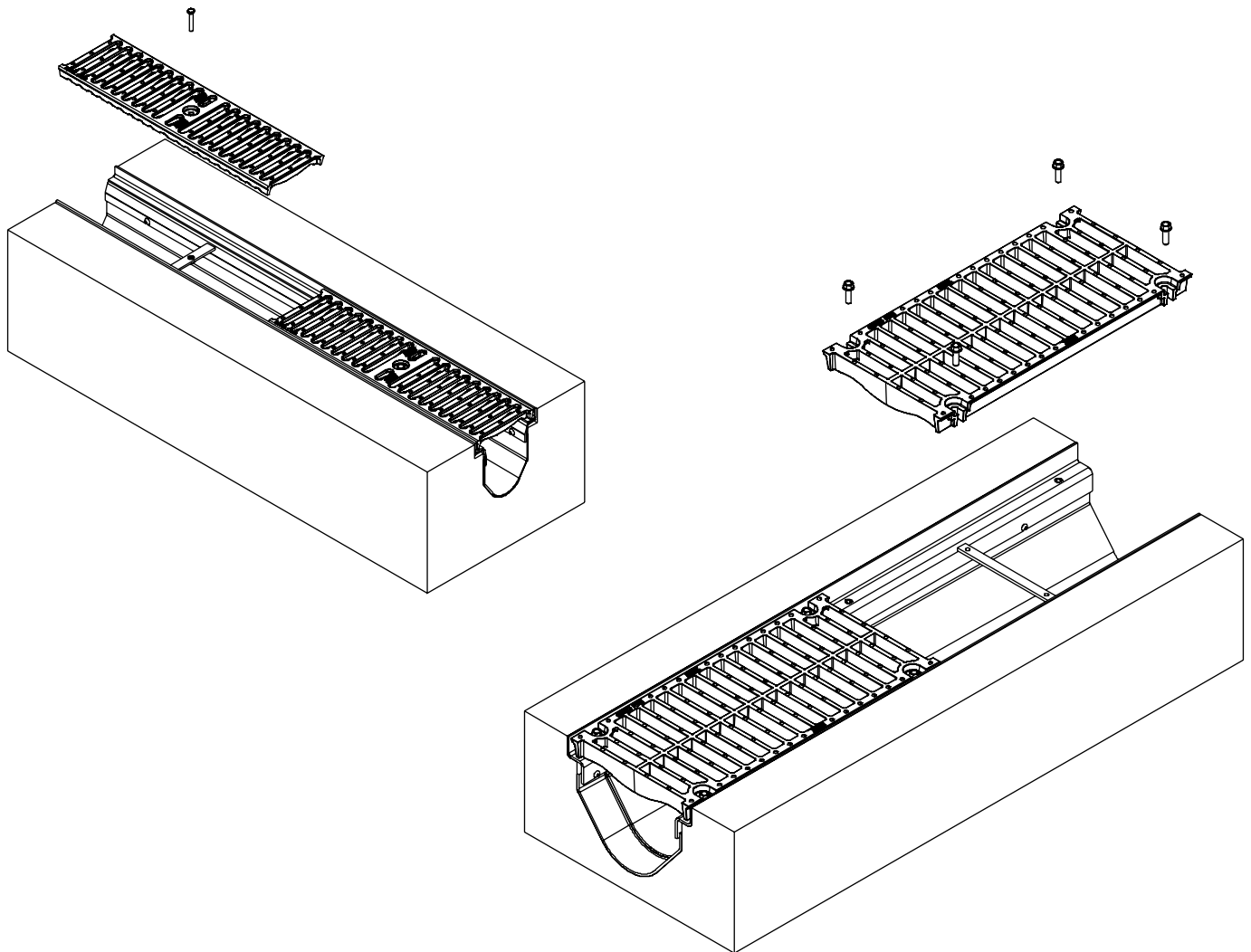

⚠ **WARNING:** Cancer and Reproductive Harm - [www.P65Warnings.ca.gov](http://www.P65Warnings.ca.gov)  
⚠ **ADVERTENCIA:** Cáncer y daño reproductivo - [www.P65Warnings.ca.gov](http://www.P65Warnings.ca.gov)  
⚠ **AVERTISSEMENT:** Cancer et effets néfastes sur la reproduction -  
[www.P65Warnings.ca.gov](http://www.P65Warnings.ca.gov)

**ZURN INDUSTRIES, LLC** Trench Drainage Operation  
1801 Pittsburgh Avenue, Erie, PA 16502, 855.663.9876

In Canada: **ZURN INDUSTRIES LIMITED** 7900 Goreway Drive, Unit 10, Brampton, Ontario L6T 5W6, 877.892.5216

Form No. ZMKTG220-02, 5/18



US 1.855.ONE.ZURN CANADA 1.877.892.5216 [ZURN.COM](http://ZURN.COM)