



AquaVantage® AV

ZER6100AV Series

AquaVantage Concealed Flushometer Installation, Operation, Maintenance and Parts Manual

Patented and Patents Pending

ZER6140AV



AquaVantage Concealed Closet Systems

ZER6140AV	ZER6152AV
ZER6142AV	ZER6153AV
ZER6143AV	ZER6154AV
ZER6144AV	ZER6196AV

AquaVantage Concealed Service Sink/Urinal Systems

ZER6150AV	ZER6195AV
ZER6155AV	ZER6197AV
ZER6190AV	

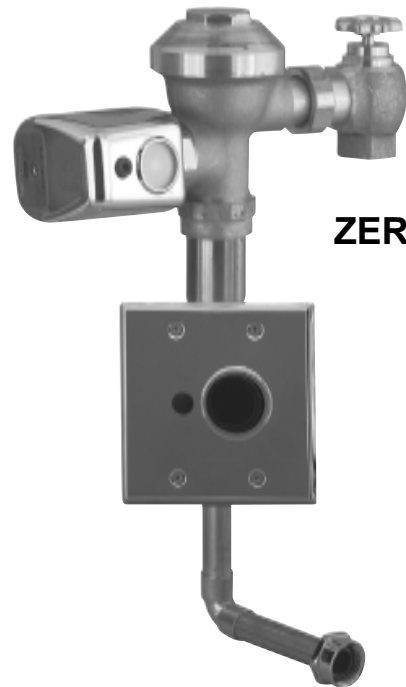

ZER6195AV

⚠ WARNING: Cancer and Reproductive Harm - www.P65Warnings.ca.gov

⚠ ADVERTENCIA: Cáncer y daño reproductivo - www.P65Warnings.ca.gov

⚠ AVERTISSEMENT: Cancer et effets néfastes sur la reproduction - www.P65Warnings.ca.gov

LIMITED WARRANTY

All goods sold hereunder are warranted to be free from defects in material and factory workmanship for a period of three years from the date of purchase. Decorative finishes warranted for one year. We will replace at no costs goods that prove defective provided we are notified in writing of such defect and the goods are returned to us prepaid at Sanford, NC, with evidence that they have been properly maintained and used in accordance with instructions. We shall not be responsible for any labor charges or any loss, injury or damages whatsoever, including incidental or consequential damages. The sole and exclusive remedy shall be limited to the replacement of the defective goods. Before installation and use, the purchaser shall determine the suitability of the product for his intended use and the purchaser assume all risk and liability whatever in connection therewith. Where permitted by law, the implied warranty of merchantability is expressly excluded. If the products sold hereunder are "consumer products," the implied warranty of merchantability is limited to a period of three years and shall be limited solely to the replacement of the defective goods. All weights stated in our catalogs and listed are approximate and are not guaranteed.

AquaVantage™ Rough-In, Product Specification, Models and Options.

ENGINEERING SPECIFICATION: ZURN AquaVantage® 'AV' Concealed Closet/Urinal Flush Valve- Concealed, quiet diaphragm type, rough brass, flushometer valve with Zurn's AquaVantage TPE, chloramine resistant, dual seal diaphragm with surface optimization and a clog resistant dynamic orifice. The valve is ADA compliant with a non-hold open and no leak handle feature, high pressure vacuum breaker, hex coupling nut and adjustable tailpiece. Spud coupling and flange for spud connection. Control stop has internal siphon-guard protection, vandal resistant cap, sweat solder kit, and a cast wall flange with set screw. Internal seals are made of chloramine resistant materials.

FLOWS:

- FF Full Flow
3.0 Gal for Urinal, 4.5 Gal for Water Closet
- WS1 Low Consumption
1.0 Gal for Urinal, 1.6 Gal for Water Closet
- WS Water Saver
1.5 Gal for Urinal, 3.5 Gal for Water Closet
(Standard Flow)

OPTIONS:

- -1 15" Tube
- -2 24" Tube
- Other

MODELS:

- ZER6140AV - 1-1/2" Water Closet valve with top spud connection.
- ZER6142AV - 1-1/2" Water Closet valve with back spud connection.
- ZER6190AV - 1-1/4" Urinal Valve with top spud connection.
- ZER6195AV - 3/4" Urinal Valve with top spud connection

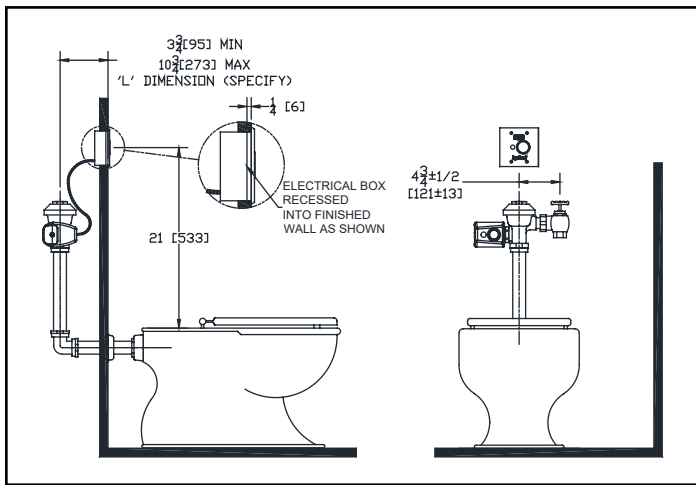

MODELS: ZER6140AV
-WS1 (WATER SAVER) 1.6 Gal. Low Consumption

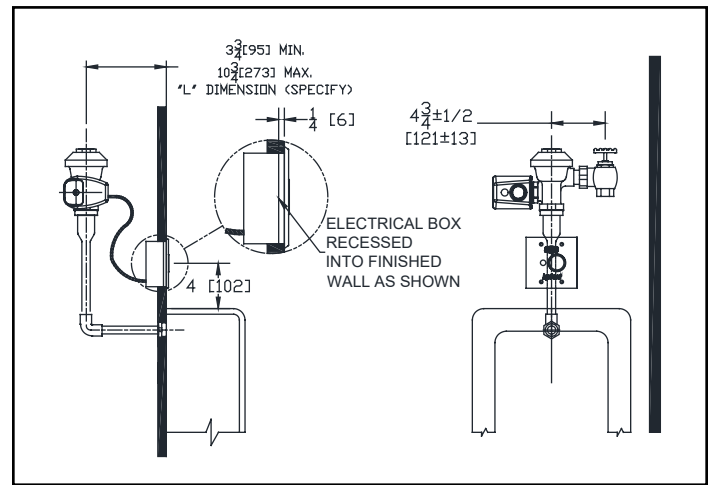

MODELS: ZER6195AV (3.4" urinal flush valve) shown, ZER6190AV (1-1/4" urinal flush valve)
-WS1 (water saver) 1.0 Gal Low Consumption

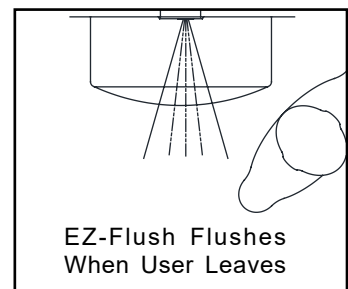
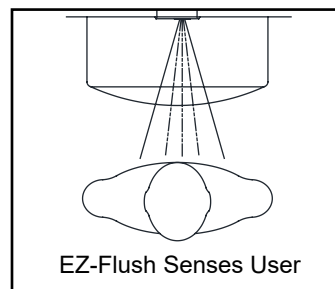
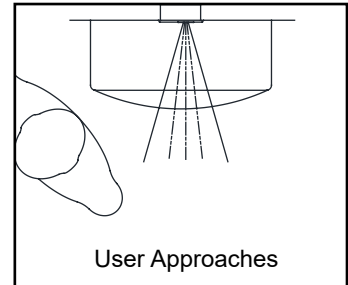
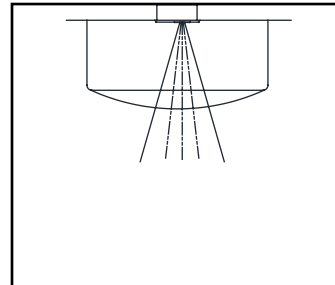
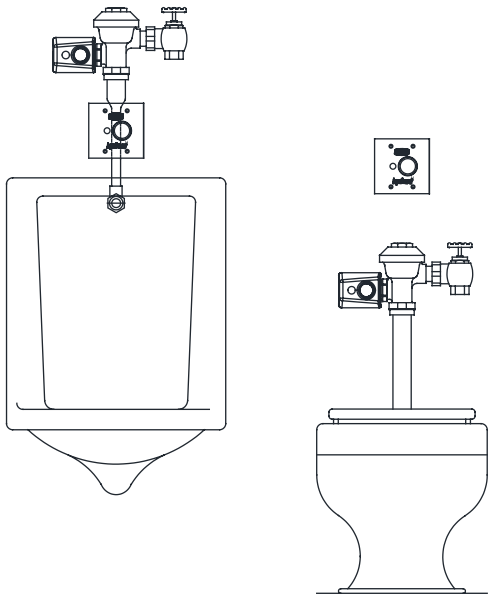

The EZ-Flush™ sends out a continuous infrared beam that is reflected back by the presence of a person in front of the urinal or toilet. The technology differentiates between someone walking past the unit or actually using the fixture. EZ-Flush models ZERK-CP and ZERK-CPM retrofit Zurn and Sloan valves. For Delaney valves, order model ZERK-CP-LY or ZERK-CPM-LY.



AquaVantage Installation Instructions

Important:

- All Plumbing is to be installed according to state and local codes and regulations.
- Water supply lines need to allow proper water flow for each fixture.
- Flush all lines of any **debris** before making connections.
- Do not use pipe sealant or plumbing grease on any fitting other than the control stop inlet.

The Aquaflush valve is designed to operate under several varieties of water pressure. The pressures fall between 10 and 100 psi (69 to 689 kPa). Each valve is tested at the lowest and highest pressures before being shipped. The minimum pressure is determined by the type of valve purchased and the Flush Flow requested. Consult your catalog for flow options.

Most Low Consumption Valves (1.6 gallon) require a minimum of 25 psi flow pressure.

When installing your quality ZURN valve it is recommended that a smooth jawed wrench is used. This will prevent gouges and scratches on your valve.

1. Install the Zurn Control Stop to the supply line with water outlet positioned as needed. If using a sweat solder adaptor, sweat the adaptor to the copper tubing before installing the control stop.

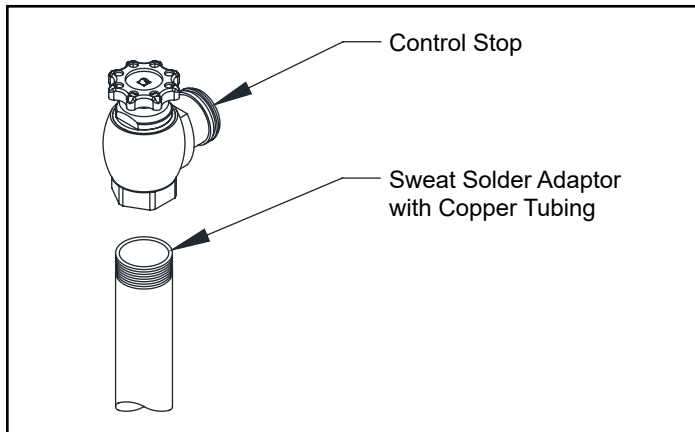

2. Attach vacuum breaker tube and elbows to fixture with spud nut.

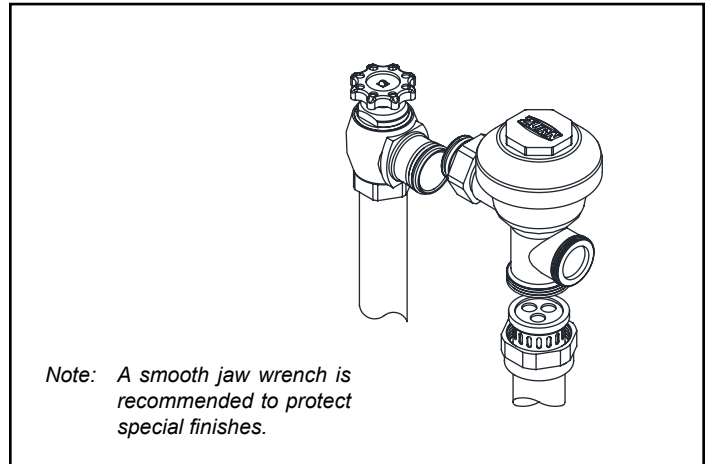
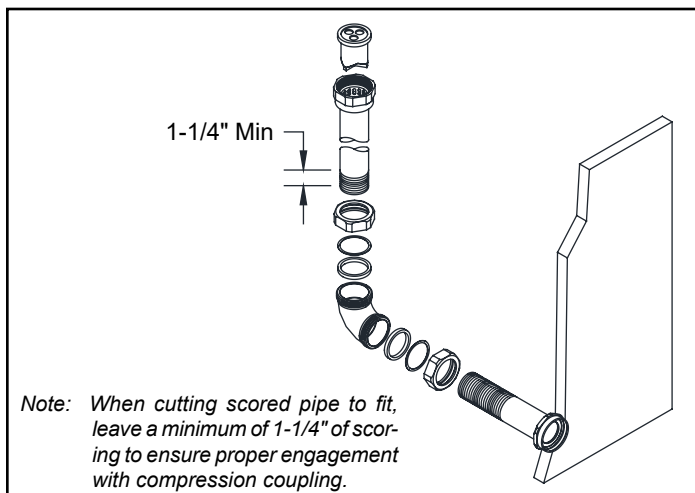

3. Insert the adjustable tailpiece into the control stop while installing the valve. Lubricate O-ring on adjustable tail piece with water if needed for installation. Secure the valve by hand tightening the actuation coupling nut. After aligning the valve securely tighten the actuator assembly, control stop and the flush tube with a wrench.

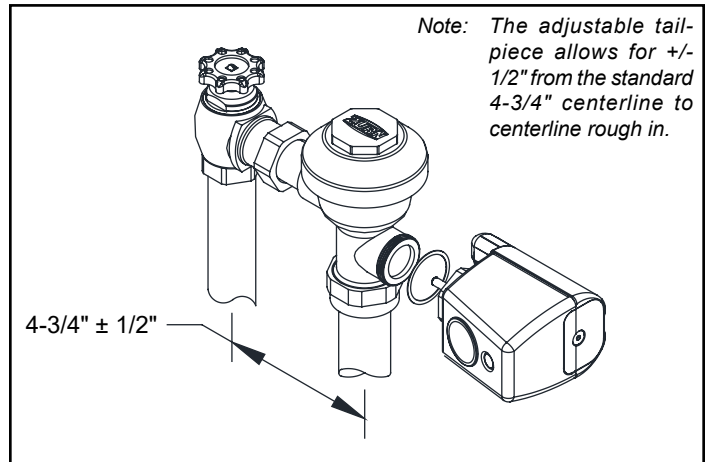

4. Before turning on water, remove the valve cover and trip mechanism. Reinstall the valve cover and open control stop to flush lines of debris. After the lines are clear, remove the cover and reinstall the trip mechanism. Tighten the cover back on and adjust flush flow using the control stop.

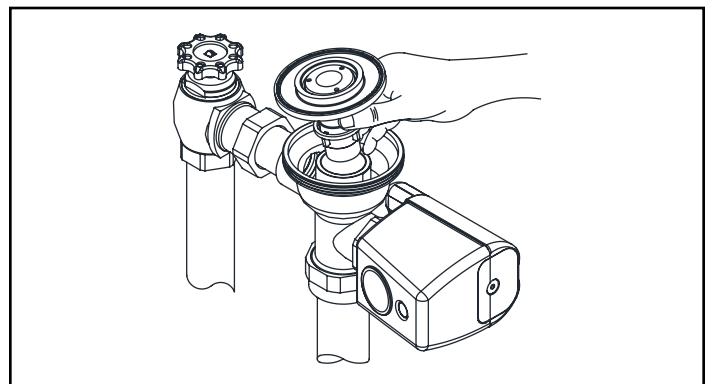

5. Activation

Using supplied battery compartment wrench, remove battery compartment from the E-Z Flush™ unit.

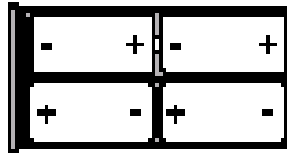

Load batteries into compartment tray (note position of batteries in tray), and reinstall battery tray into the E-Z Flush unit.

Secure tray with battery compartment wrench. The last three turns of the wrench will activate the E-Z Flush unit. The E-Z Flush System is now operational.

Your E-Z Flush unit comes preset from the factory. If special circumstances require adjustment of the activation distance, see Section 8 – “Adjusting Your E-Z Flush.”

The E-Z Flush unit has a 10-minute start-up sequence in which the sensor will flash the User-In-View yellow L.E.D. continuously as long as a user is in view. After the start-up sequence is completed and when the sensor has a user in view, the User-In-View yellow L.E.D. will flash only 3 times after a 5-second delay. This delay prevents needless flushes when someone walks by.

Sensor units should not be located across from each other or in close proximity to highly reflective surfaces.

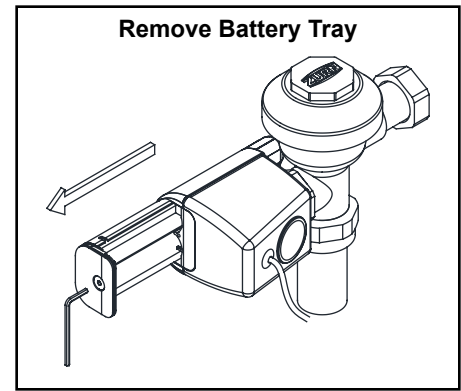

Load Batteries as illustrated.

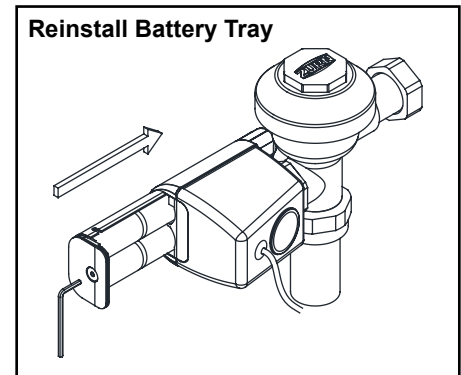

6. Visual Indicator Guide

USER-IN-VIEW L.E.D. Yellow light flashes 3 times – after 5-second delay – when a user is in view. The yellow light flashes constantly when a user is in view during the 10-minute start-up sequence.

OBJECT LOCK SENSOR

BATTERY L.E.D. Red light flashes indicating it is time to replace batteries with 4 new “C” batteries.

Sensor Connection Cable

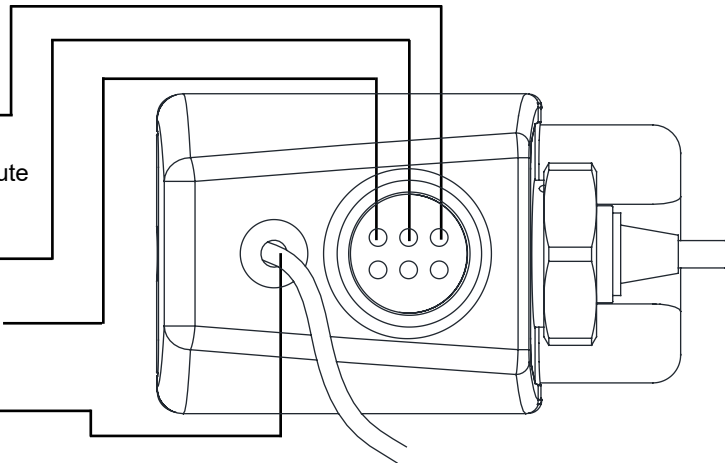

8. Adjusting your E-Z Flush

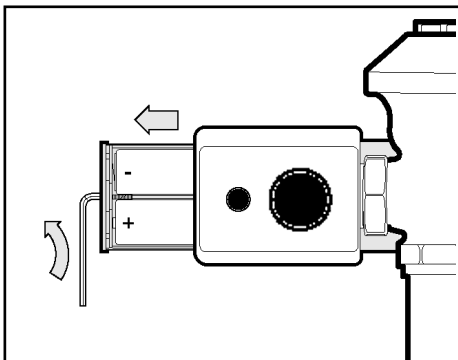

Use battery compartment wrench to remove battery compartment tray.

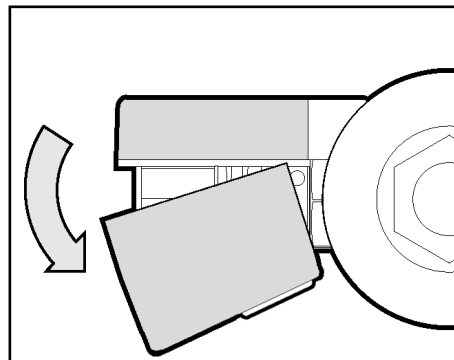

Pull cover off by rotating battery side forward and out.

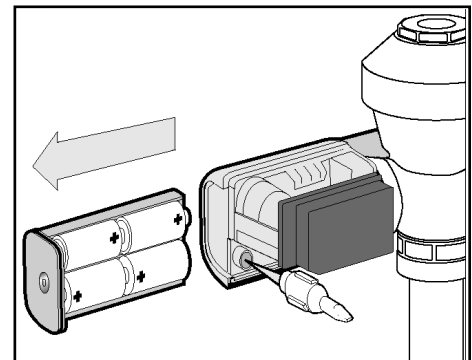

Sensor Adjustor Tool comes in a built-in storage pocket. Replace after use.

9. To Change Activation Distance for the Sensor

1. Remove screws attaching coverplate to wall and remove coverplate.
2. Have an individual stand at desired activation distance. Yellow L.E.D. will flash continuously when it has an object in view for the 10 minute reset period. See Step 5, "Activation".
3. Use sensor adjustor tool and turn **Sensor Range Adjustment Screw** all the way down and then turn slowly up until **yellow L.E.D.** begins to flash.
4. Ensure sensor is not detecting stall door or wall by closing door, stepping out of sensor path and making sure **yellow L.E.D.** is not flashing. If sensor lo'ttch with screws.
6. After 10-minute start-up sequence, the **yellow L.E.D.** will flash only 3 times when a user is in view (after a 5-second delay).

10. Wiring Diagram

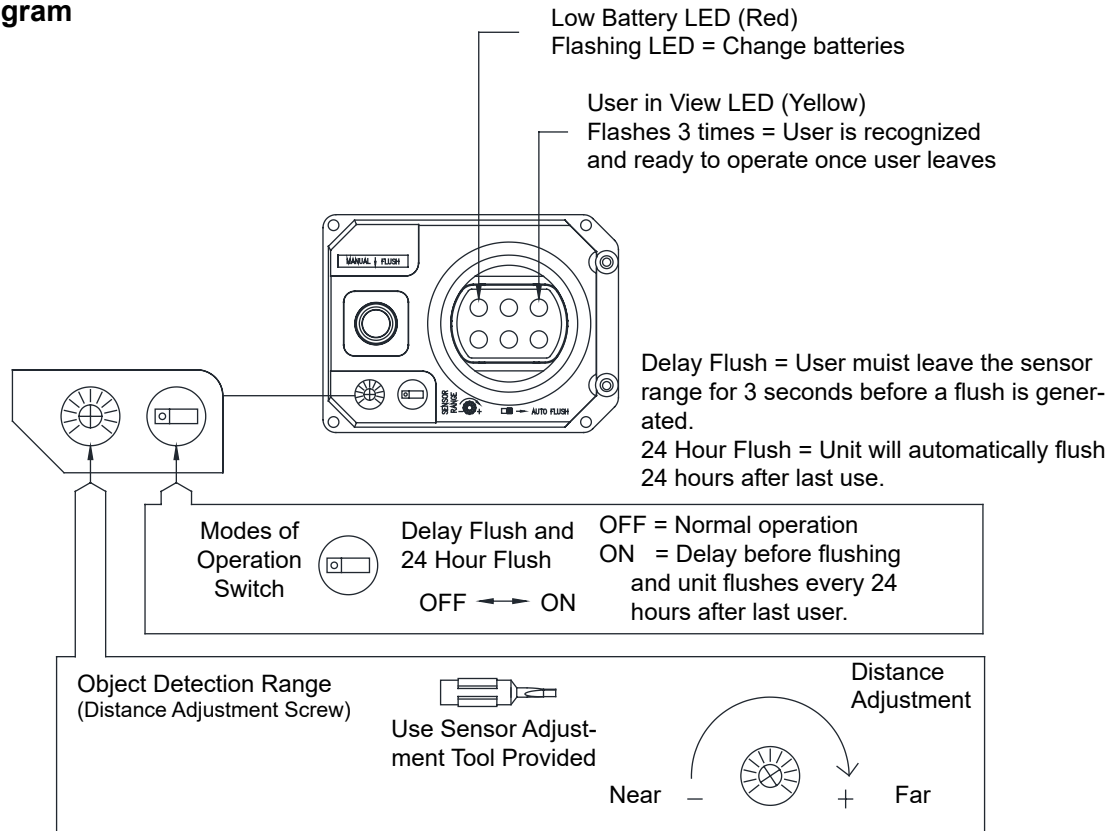

EZ Flush Troubleshooting Guide

PROBLEM	CAUSE	SOLUTION
Yellow L.E.D. light flashes 3 times when there are no users.	Front of Object Lock Sensor is covered or Object Lock Sensor is set too far out, registering the opposite wall or door as a user.	Remove item covering sensor or adjust Object Lock Sensor activation distance. (See Appendix B – Adjusting the E-Z Flush.)
Yellow L.E.D. light flashes continuously when Object Lock Sensor is activated by a user.	E-Z Flush unit is in 10-minute start-up mode (when first activated), or Sensor Range Reset Button has been depressed.	Yellow L.E.D. light will flash only 3 times, acknowledging a user is in view after the 10-minute start-up mode.
Red L.E.D. light flashes.	Batteries need replacing.	Replace batteries and wait 10 minutes for unit to boot up
Not enough water to fixture or too much water to fixture.	Diaphragm damaged or valve control stop improperly adjusted.	Replace diaphragm and/or adjust valve control stop.
Valve will not operate.	Object Lock Sensor range set too close to E-Z Flush, batteries are dead, or water supply is turned off.	Adjust Object Lock Sensor, replace batteries, or turn water on. If the E-Z Flush does not begin to function, call Customer Service at 1-800-997-3876.
Valve does not shut off.	Dirt or debris preventing diaphragm from functioning properly.	Remove dirt or debris, check by-pass hole in diaphragm.
Valve does not flush even after Object Lock Sensor has been adjusted.	Batteries are dead.	Replace batteries and wait 10 minutes for unit to boot up. If the E-Z Flush does not begin to function, call Customer Service at 1-800-997-3876.



AquaVantage™ Concealed Repair Kits

Parts Identification

1. Wheel Handle Screw
2. Wheel Handle
3. Stop Cap
4. Adjusting Screw
5. Guide Holder
6. Piston Guide
7. Guide O-Ring
8. Stop Spring
9. Piston
10. Piston Seal
11. Stop Body
12. Locking Nut
13. Tailpiece O-Ring
14. Snap Ring
15. Tailpiece
16. Valve Body Cover
17. Plastic Cover
18. Trip Mechanism
19. Diaphragm Repair Kit
20. Valve Body
21. EZ handle Nut Wrench
22. Vacuum Breaker Insert
23. Vacuum Breaker Duckbill
24. Vacuum Breaker Tube
25. Vacuum Breaker Tube Nut
26. Coupling Nut
27. Spud Friction Washer
28. Spud Rubber Gasket
29. 90 Degree Elbow
30. Spud Nut
31. Flanged/Scored Horizontal Tube
32. P30 Flat Gasket
33. 3/4" 90 Degree Elbow
34. 3/4" Horizontal Tube
35. 3/4" Spud Nut
36. Spud Friction Washer
37. Spud Rubber Gasket
38. Gasket
39. EZ Flush Unit
40. Sensor connection cable (PERK6000-CONC-CW)
41. 4x4 electrical box
42. Sensor mounting plate
43. EZ Flush Sensor
44. Sensor Cover plate (PERK6000-CONC-22)
45. Sensor mounting screws
46. Sensor plate mounting screws (PH6000-HY35)
47. EZ Battery Tray Hex Wrench

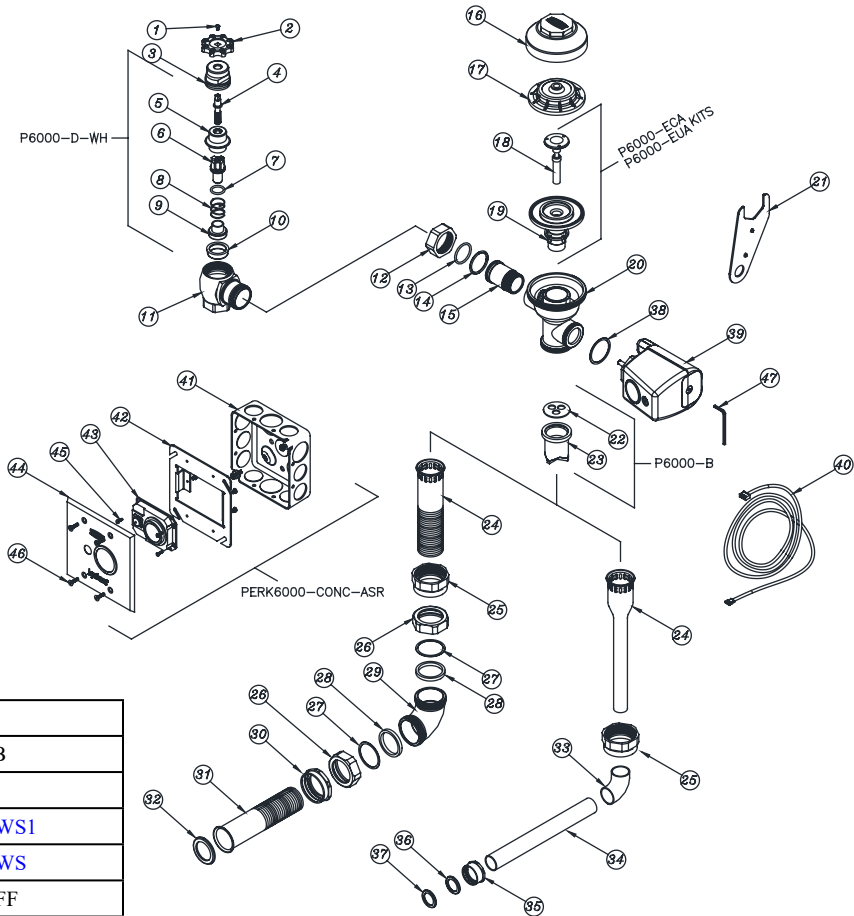

Covers and Repair Kits	Product No.
Outside Cover - RB - Item 16	P6000-LL-RB
Inside Cover - Item 17	P6000-L
Low Consumption Closet Kit - 1.6 gal. flush	P6000-ECA-WS1
Water Saving Closet Kit - 3.5 gal. flush	P6000-ECA-WS
Full Flow Closet Kit - 4.5 gal. flush	P6000-ECA-FF
Low Consumption Urinal Kit - 1.0 gal. flush	P6000-EUA-WS1
Water Saving Urinal Kit - 1.5 gal flush	P6000-EUA-WS
Full Flush Urinal Kit - 3.0 gal. flush	P6000-EUA-FF

EZ Flush Repair Kits	Product No.
Sensor Connection Cable, Item 40	PERK6000-CONC-CW
Sensor and Connection Cable, Items 40, 43	PERK6000-SR-CONC
EZ Flush Unit	PERK6000-MO
Concealed Sensor and Box Kit, Items 41-46	PERK6000-CONC-ASR

AquaVantage Rebuild Kits	Product No.
Closet and Urinal Rebuild Kits Include Items 13, 18, 19, 22, 23	P6000-ECA-WS-RK
	P6000-ECA-WS1-RK
	P6000-ECA-WS1-RK
	P6000-EUA-WS-RK
	P6000-EUA-WS1-RK

Control Stop Repair Kit and Parts	Product No.
Control Stop Repair Kit for 1" and 3/4", Includes Items 5-10	P6000-D-SD
Seal Seat for 1" and 3/4", Includes Item 10	P6000-D42
Sweat Solder Connection	P6000-YBA

Adjustable Tailpieces	Product No.
Adjustable Tailpiece for Standard Flush Valve	P6000-J1-RB
Includes Items 13-15	
Tailpiece Locking Ring Includes Item 14	P6000-C30
Tailpiece O-Ring Includes Items 15	P6000-C31
Coupling Nut Includes Item 12	P6000-C32-RB

Flush Connections and Spud Coupling Kits	Product No.
Flush Tube Assembly for Concealed Flush Valves	P6000-Q_ _
Refer to Section Q in Aqua Parts Guide	
Specify 'L' Dim. and Valve Used	
Vacuum Breaker Repair Kit Includes Items 22-23	P6000-B
Spud Coupling Assembly (Specify Size)	P6000-HN

Repair Parts - Inside Parts	Product No.
Urinal Relief Valve - Item 18	P6000-EU13
Closet Relief Valve - Item 18	P6000-EC13



AQUAVANTAGE TROUBLE SHOOTING

Problem	Cause*	Corrective Action*
Valve will not operate.	1.) Stop valve is closed 2.) Supply valve is closed.	1.) Open Stop valve. 2.) Open supply valve.
Insufficient volume of water to adequately siphon fixture.	1.) Stop valve not open enough. 2.) Urinal trip mechanism installed in wrong kit, urinal or closet. 3.) Insufficient volume or pressure at supply.	1.) Open stop valve for desired volume of water. 2.) Replace urinal part with proper closet valve part. 3.) If gauges are not available to measure supply pressure or volume of water at the valve, completely remove the working parts and open the stop valve to allow water to pass through the empty valve. If the supply is adequate to siphon the fixture the Guide Ring may be removed from the guide assembly to provide additional flow. Should this prove unsatisfactory, steps should be taken to increase the pressure and/or supply.
Flush valve shuts off too quick.	1.) Damaged or punctured diaphragm. 2.) Enlarged bypass orifice.	1.) Install new Z6000-EU replacement kit to remedy the problem. 2.) Install new Z6000-EC, Z6000-EU replacement kit to remedy the problem.
Valve is short flushing.	1.) Cylinder guide assembly and diaphragm assembly are not tight. 2.) Enlarged bypass orifice. 3.) Urinal trip mechanism in closet flush valves.	1.) Screw the two assemblies hand tight. 2.) Install new Z6000-EC, Z6000-EU replacement kit to remedy the problem. 3.) Install closet trip mechanism (white#13).
Valve is flushing too long or not shutting off.	1.) Trip mechanism not seating properly due to foreign material between trip mechanism and retainer disc. 2.) Bypass orifice is plugged or partially plugged. 3.) Line pressure is not adequate to force trip mechanism to seal. 4.) Cracked cover.	1.) Disassemble parts and rinse thoroughly. 2.) Examine bypass orifice and clean if necessary being certain not to enlarge orifice opening. 3.) Pressure is inadequate or has dropped below minimum operating range. Steps should be taken to increase the line pressure. 4.) Replace cover with new one.
Water splashes out of fixture.	1.) Supply volume is more than is necessary. 2.) Lime accumulation on vortex or spreader holes of fixture.	1.) Adjust downward on control stop. 2.) Remove the lime build up.
Flush is not considered quiet.	1.) Control stop may not be adjusted for quiet operation 2.) Fixture may be contributing to noise 3.) Piping system may be source of noise.	1.) Adjust the control stop for quiet operation keeping in mind the fixture evacuation requirements. 2.) Check noise created by fixture by placing a cover over the bowl opening to separate valve noise from bowl noise. If it is determined the fixture is too noisy consult with fixture manufacturer. 3.) High pressure in the system can sometimes be controlled by the stop valve. Other sources of noise may be the absence of air chambers and shock arrestor, loose pipes, improper size pipes, etc. In these cases the building engineer should be consulted.
Chattering noise in flush valve.	1.) Segment diaphragm has been installed upside down. 2.) The inside cover has been distorted by freezing or abuse.	1.) Reposition segment diaphragm as instructed by the markings on the diaphragm (this side down). 2.) Replace both inside plastic cover and outside chrome plated brass cover.

Care of Chrome plated surfaces.

The suggested cleaning of chrome plated surfaces is simply to clean them with soap and water then dry. Commercial cleaning compounds are never recommended.

Seasonal use.

Valves used in installations subject to shut down because of cold and freezing conditions should be maintained in the following manner. After the main supply has been shut off and the water drained from the system, remove the stop valve cap and stop internals to allow the water to drain from the flush valve itself.

Printed in the U.S.A.

