



AquaSense®

ZER-TM Series

Automatic Sensor-Operated Gear Driven Type Flushometer for Water Closets and Urinals

Installation, Operation, Maintenance and Parts Manual



Water Closet Models:

ZER6000AV-ONE-TM	1.1 gpf
ZER6000AV-HET-TM	1.28 gpf
ZER6000AV-WS1-TM	1.6 gpf
ZER6000AV-DF-TM	1.1/1.6 gpf

Power Options:

Battery (Standard)

Urinal Models:

ZER6003AV-ULF-TM	0.125 gpf
ZER6003AV-EWS-TM	0.5 gpf
ZER6003AV-WS1-TM	1.0 gpf

Compliance:

- ADA Compliant
- ASSE 1037/ASME A112.1037/CSA B125.37
- cUPC
- Texas Accessibility Standard (TAS)
- WaterSense Compliant

⚠ **WARNING:** Cancer and Reproductive Harm - www.P65Warnings.ca.gov

⚠ **ADVERTENCIA:** Cáncer y daño reproductivo - www.P65Warnings.ca.gov

⚠ **AVERTISSEMENT:** Cancer et effets néfastes sur la reproduction - www.P65Warnings.ca.gov

LIMITED WARRANTY

All goods sold hereunder are warranted to be free from defects in material and factory workmanship for a period of three years from the date of purchase. Decorative finishes warranted for one year. We will replace at no costs goods that prove defective provided we are notified in writing of such defect and the goods are returned to us prepaid at Sanford, NC, with evidence that they have been properly maintained and used in accordance with instructions. We shall not be responsible for any labor charges or any loss, injury or damages whatsoever, including incidental or consequential damages. The sole and exclusive remedy shall be limited to the replacement of the defective goods. Before installation and use, the purchaser shall determine the suitability of the product for his intended use and the purchaser assumes all risk and liability whatever in connection therewith. Where permitted by law, the implied warranty of merchantability is expressly excluded. If the products sold hereunder are "consumer products," the implied warranty of merchantability is limited to a period of three years and shall be limited solely to the replacement of the defective goods. All weights stated in our catalogs and lists are approximate and are not guaranteed.

NOTICE: READ ENTIRE MANUAL PRIOR TO INSTALLING PRODUCT

ZER-TM Series Flush Valve Package Contents

ZER6000AV-TM

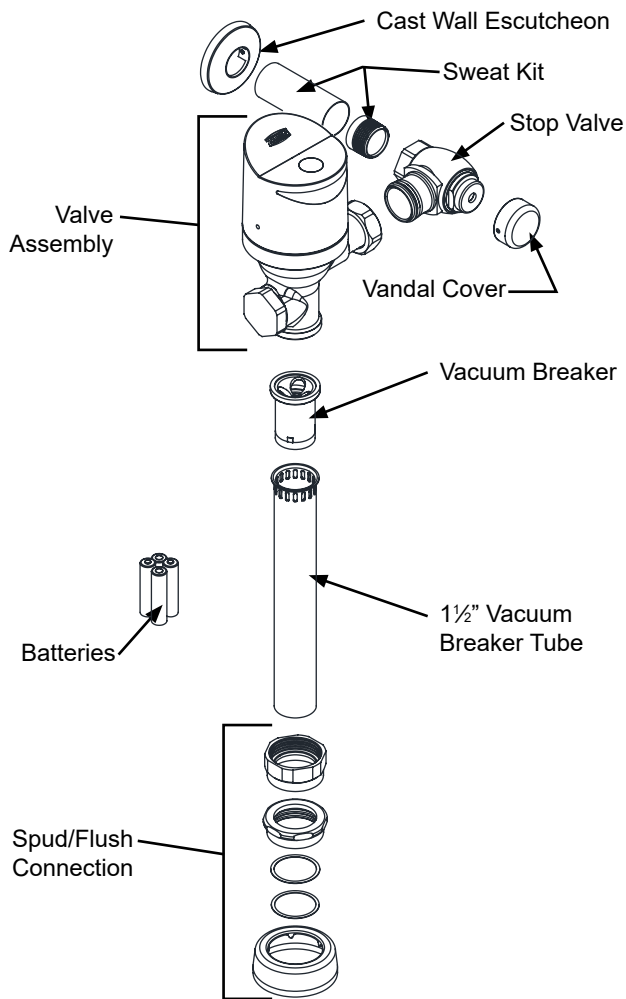

ZER6003AV-TM

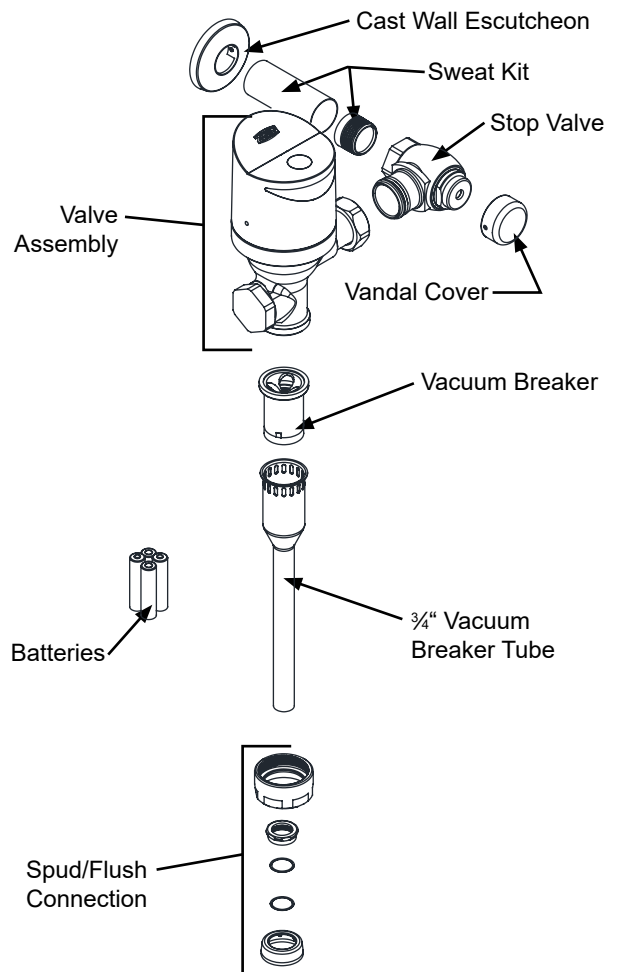

Required Tools



3/32", 5/64"
Allen Wrench
(Supplied)

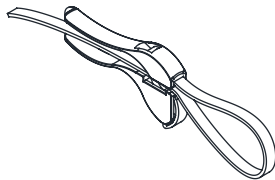

Strap Wrench
(Supplied)

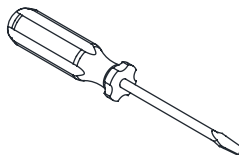

Flat Head
Screwdriver

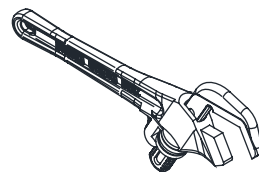

Smooth Jawed
Wrench

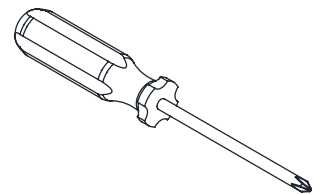

Phillips Head
Screwdriver

Optional Accessories



Magic Magnet
P6900-AT-MAG

Overview:

Zurn Aqua-Sense® ZER-TM Series Flushometer offers two models (closet/urinal) in a variety of flow rates. The ZER-TM design is a chrome plated brass body with an automatic sensor-operated gear driven valve. The flushometer incorporates a filtered bypass, high back pressure vacuum breaker, adjustable tailpiece, spud coupling, flange for top spud connection and an electronic override pushbutton (MOB) for alternative flushing method. The control stop has internal siphon-guard protection, vandal resistant stop cap, sweat solder kit, and cast wall flange with set screw. All internal and external gaskets and seals are chloramine resistant.

Specifications:

Voltage: 6 VDC Series [4 "AA" 1.5V Lithium Cells] or 6 VDC Series [4 "AA" 1.5V Alkaline Cells]

Sensor Range: Factory set for user at end of elongated bowl or field adjustable by installer

Important Safety Information:

- Installer is responsible for ensuring the product is installed and conforms to all plumbing codes and ordinances.
- Do not convert or modify this Zurn product yourself. All warranties will be voided.
- Water supply lines must be sized according to building designer in order to provide adequate water supply for each fixture.
- Flush all water lines prior to making connections.

Prior to Installation:

- The ZER-TM flushometer is designed to operate optimally between 25 psi (running) to 80 psi (static) water pressure (172 to 552 kPa). Higher running pressure may be required for some fixtures. Consult fixture manufacturer for details.
- When installing a flushometer, it is important that the flush volume matches the requirements of the plumbing fixture.
- To protect chrome finish, do not use toothed tools to install or service the flushometer.
- Before installing your Zurn® Gear Driven Flush valve, the items listed below should already be installed on site:
 - Closet or urinal fixture
 - Fixture carrier
 - Drain line
 - Water supply line

NOTE: The information in this manual is subject to change at any time without notice. Installations may be performed at different times of construction by different individuals. For this reason, these instructions should be left on-site with the facility or maintenance manager.

Sweat Solder Adapter Installation Instructions - STEP 1

NOTE: Before installation, turn off water supplies to existing fixture and remove flushometer if replacing an existing device.

1. Measure distance from finished wall to the center line of the fixture spud. If necessary, cut water supply pipe 1-1/4" shorter than this measurement. Deburr by chamfering O.D. and I.D of end of water supply pipe.

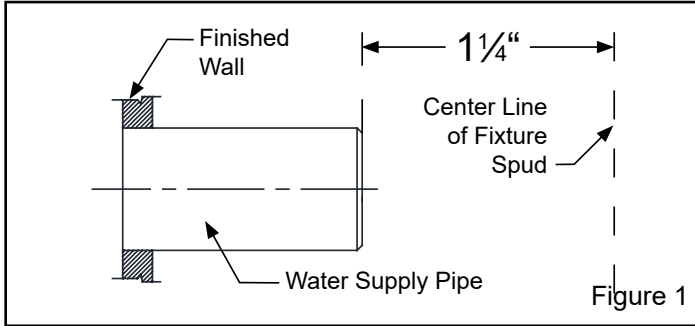

2. Slide threaded sweat solder adapter onto water supply pipe until shoulder stops on end of pipe. Then sweat-solder the adapter to water supply pipe.

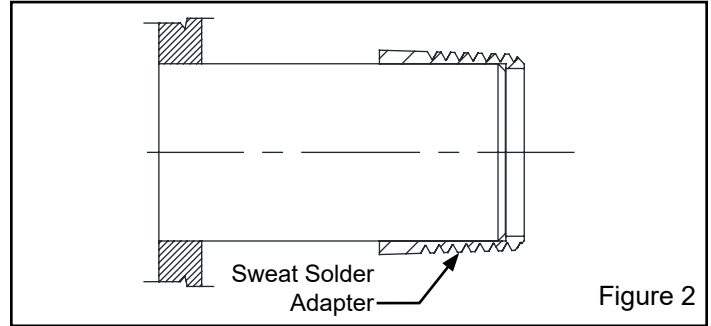

3. Measure distance from finished wall to first thread of sweat solder adapter. If necessary, cut chrome cover tube this length.

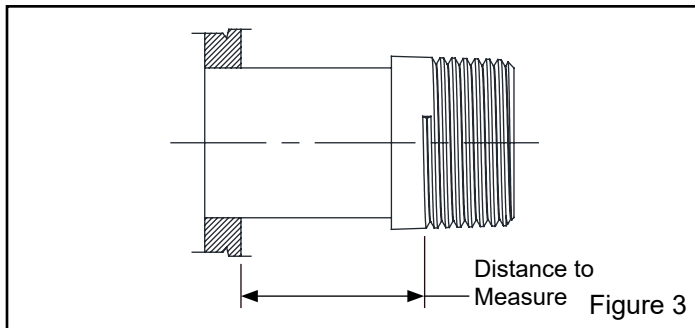

4. Slide wall escutcheon over chrome cover tube and slide both items over water supply pipe. Press wall escutcheon flush against finished wall and tighten set screw with hex wrench (supplied) to secure it in place.

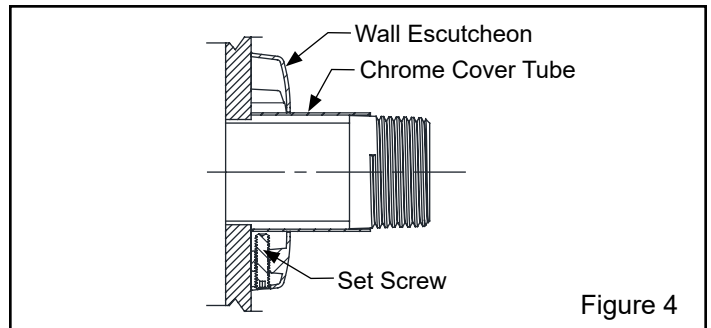

Control Stop Installation Instructions - STEP 2

1. Install control stop assembly by threading it onto water supply pipe and tightening with a smooth jawed wrench. Apply thread sealing compound or pipe tape to male NPT thread on sweat solder adapter only. Prior to turning on main water supply line ensure all stop valves are closed off tight by using a flathead screwdriver and turning the stop valve adjustment screw clockwise.

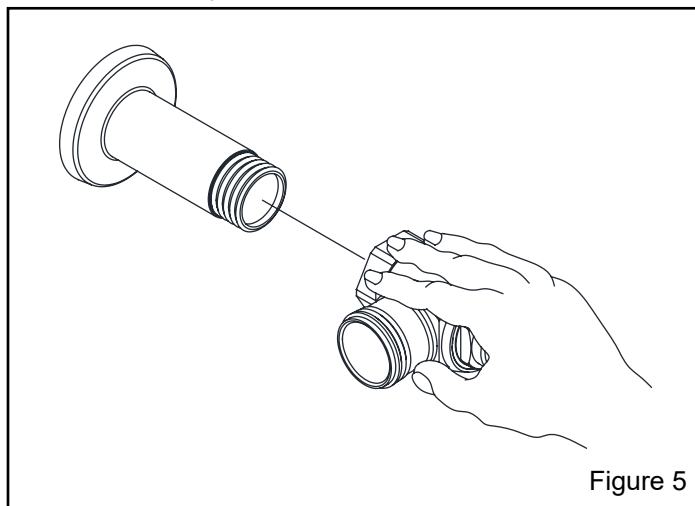

2. When all stop valves are properly connected to the water supply line and water pressure is available open the control stop using a flathead screwdriver and turning the stop valve adjustment screw counterclockwise. Allow the water supply line to flush any debris or sediment that may be present in the line. Close the control stop once the lines are completely flushed.

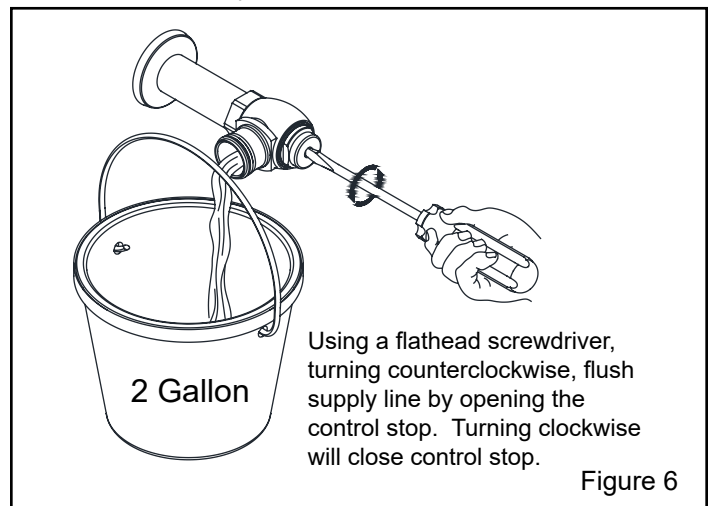

Flush Valve Installation - STEP 3

STEP 3.1

Prior to attaching flush valve to control stop(A) inspect and verify that the O-ring (C) is located within the O-ring groove at the tailpiece. Ensure the locking nut (D) and locking snap ring (E) are also present on the tailpiece. See Figure 7.

When installing the valve with the control stop on left side of the valve, continue to install with the sensor facing the wall. After Step 3.4, go to the Sensor Angle Adjustment Section before advancing to Step 4 - Battery Installation.

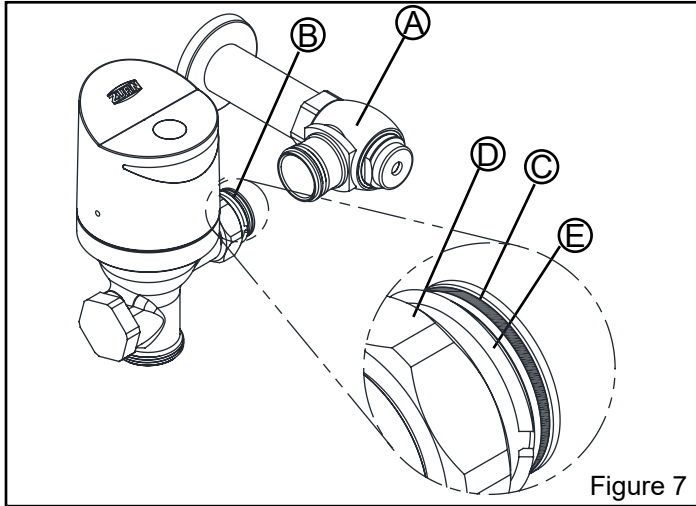

Figure 7

STEP 3.2

Lubricate O-ring with water and carefully insert flush valve tailpiece into the control stop valve to ensure O-ring remains seated. Tighten locking nut using a smooth jawed wrench. See Figure 8.

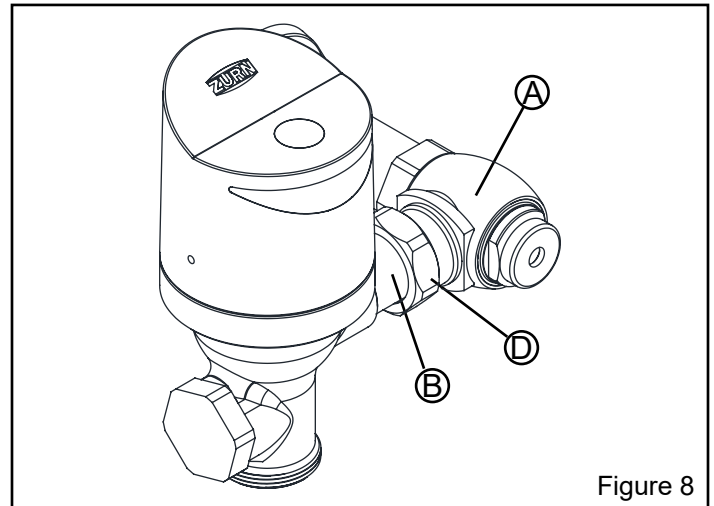

Figure 8

STEP 3.3

Determine the length of vacuum breaker tube required to join the flush valve and fixture spud, and cut if necessary.

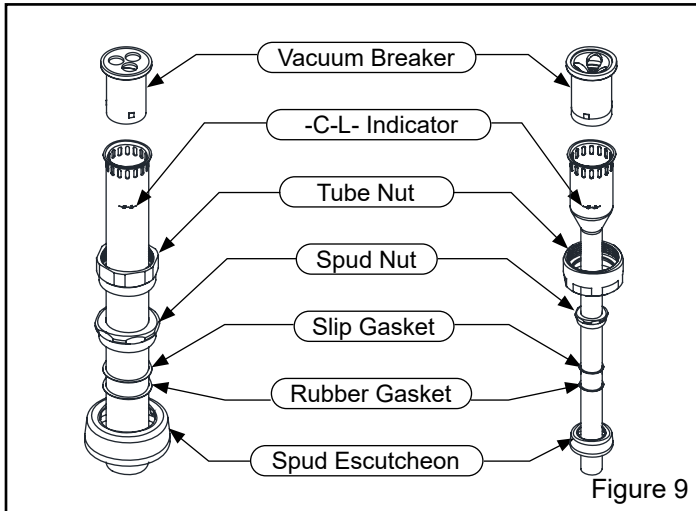

Figure 9

⚠ DO NOT use pipe sealant or plumbing grease on any valve component or coupling with the exception of the Control Stop Inlet! Ensure Vacuum Breaker does not twist or warp when tightening Vacuum Breaker Tube Nut.

STEP 3.4

Slide the tube nut, spud nut, slip gasket, rubber gasket and spud escutcheon over the vacuum breaker tube and insert tube into fixture spud. Hand tighten tube nut to valve body and hand tighten spud nut onto fixture spud. Adjust the valve assembly for plumb. Tighten fixture spud nut, vacuum breaker tube nut and lock nut with a wrench.

Adjust and plumb the valve assembly. Tighten all connections with smooth jawed wrench and turn on water supply at the control stop. See Figure 9.

⚠ DO NOT cut vacuum breaker tube shorter than 6" below the -C-L- indicator mark, as vacuum breaker must be 6" above the fixture. Consult plumbing Codes & Regulations for specific details.

Battery Installation - STEP 4

STEP 4.1

Use the 3/32" Allen Wrench to loosen the internal set screw counter-clockwise until it stops. Screw will retract into the shell.

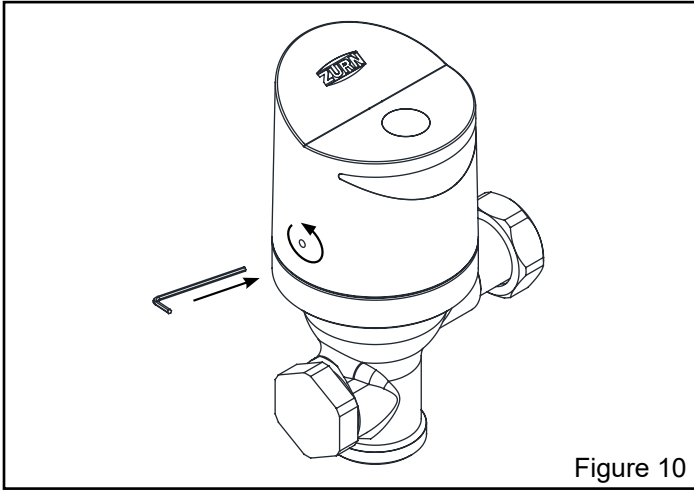

Figure 10

STEP 4.2

Remove the valve cap by turning it counter-clockwise and lifting gently. Disconnect the wire harness before fully removing valve cap.

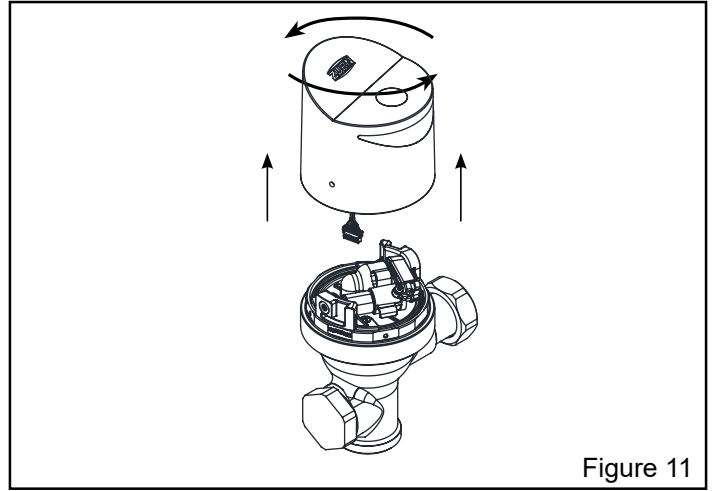

Figure 11

STEP 4.3

Flip the valve cap upside down on a flat, soft surface. Loosen the knurled screw by hand to remove the battery cap. Use flat head screwdriver to loosen knurled screw if necessary.

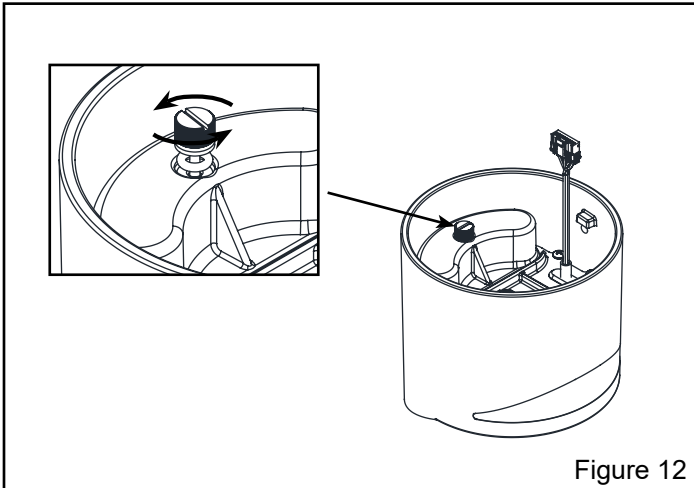

Figure 12

STEP 4.4

Remove the battery cap from the battery housing.

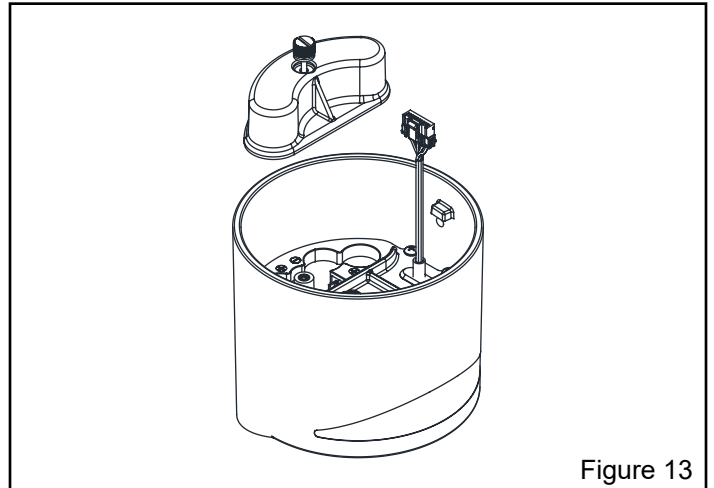

Figure 13

STEP 4.5

Insert four batteries (supplied) into battery housing and ensure the batteries are inserted in the correct orientation. Use AA Lithium Batteries or AA Alkaline batteries, but do not mix Lithium with Alkaline.

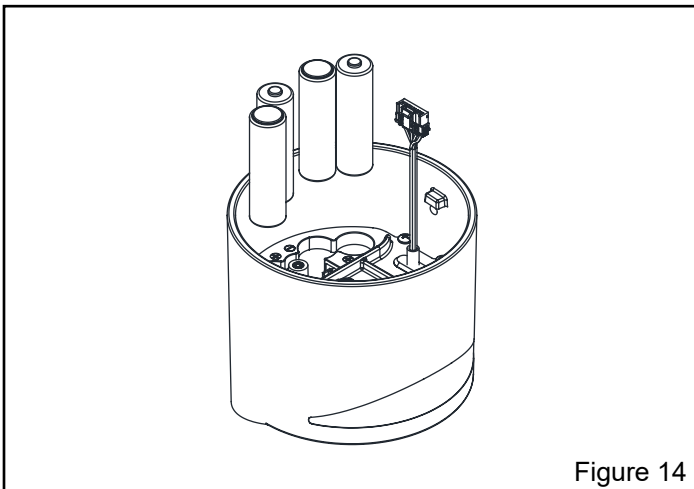

Figure 14

STEP 4.6

See notes below and reverse steps 4.1 - 4.4 to reinstall battery cap and valve cap onto valve body. Then, turn control stop back on by turning counter-clockwise using a flat head screw driver.

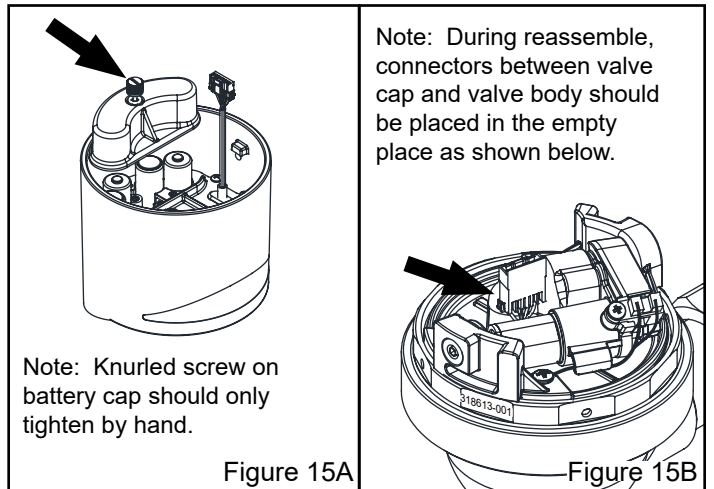

Figure 15A

Figure 15B

Sensor Angle Adjustment (when necessary)

STEP 1

Turn off control stop using a flat head screw driver turning clockwise (See Figure 16). Then, use the electronic override button to flush the water out of the flush valve.

STEP 2

Before loosening the locking ring, make sure the strap wrench and locking ring are completely dry so that the strap wrench has the best grip possible on the locking ring.

Mark down Locking ring original position relative to valve body with tape or marker. Loosen locking ring (See Figure 16) on valve head using strap wrench (supplied) turning counter-clockwise. If unable to loosen the locking ring with the strap wrench. Then remove the valve cap from the valve head shown in Step 4.1 & 4.2 of the Battery Installation Section. The supplied strap wrench or a large wrench may be used on the flats of the locking ring to loosen it.

STEP 3

Rotate flush valve head to adjust sensor angle. If the valve cap was removed to loosen the locking ring, rotate the manifold to have the location mark pointing perpendicular to the wall (Figure 16B).

STEP 4

Before tightening the locking ring, make sure the strap wrench and locking ring are completely dry so that the strap wrench has the best grip possible on the locking ring.

Tighten locking ring back to original position with strap wrench (supplied) by turning clockwise.

STEP 5

Turn control stop back on by turning counter-clockwise using a flat head screw driver.

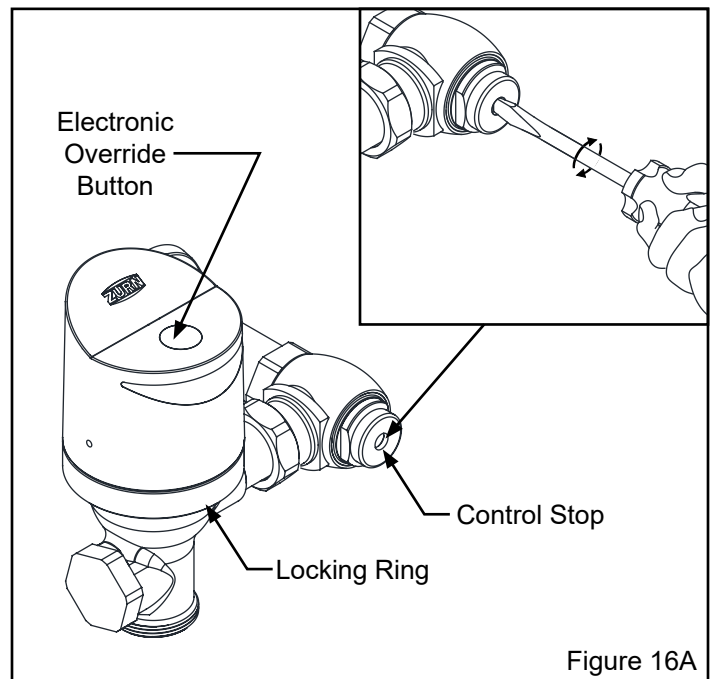

Figure 16A

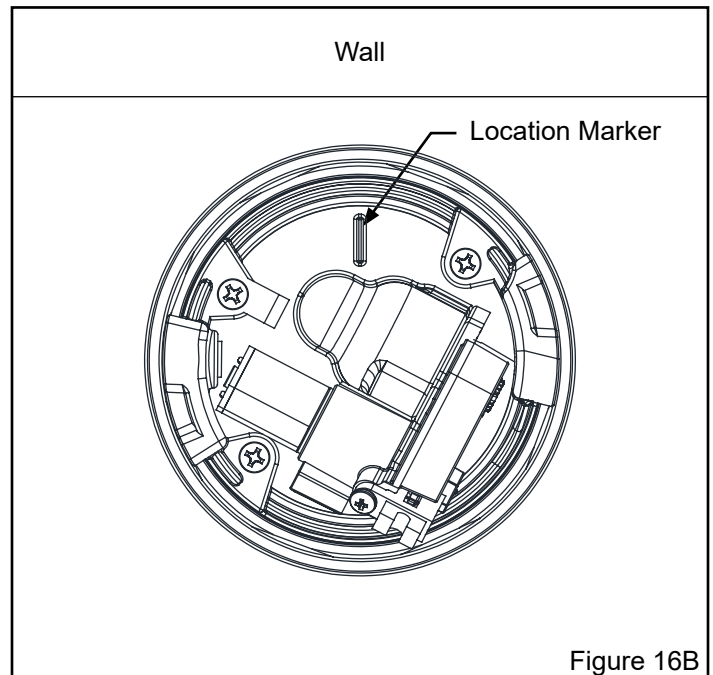

Figure 16B

Diaphragm Replacement and Cleaning (when necessary)

STEP 1

Turn off control stop using a flat head screw driver turning clockwise (See Figure 16 above). Then, use the electronic override button to flush the water out of the flush valve.

STEP 2

Before loosening the locking ring, make sure the strap wrench and locking ring are completely dry so that the strap wrench has the best grip possible on the locking ring.

Mark down Locking ring original position relative to valve body with tape or marker. Uninstall valve head by loosening locking ring (See Figure 16 above) using strap wrench (supplied) turning counter-clockwise.

STEP 3A - Cleaning Diaphragm Kit

Slide out existing diaphragm kit off manifold stem. Wash diaphragm and orifice thoroughly with water. Slide cleaned diaphragm back on to manifold stem orienting the orifice opposite of the control stop. If cleaning diaphragm and orifice do not resolve issue, follow step 3B.

⚠ Do not to damage or enlarge orifice. Doing so will result in incorrect flush rate.

STEP 3B - Replace Diaphragm Kit

Slide out existing diaphragm kit off manifold stem. If the o-rings are worn, replace them with the new o-rings provided in the diaphragm repair kit. Then replace the old diaphragm kit with a new diaphragm kit (of the same flow rate) into the valve body, carefully orienting the orifice opposite of the control stop. (There is no need to replace the Volume Control Ring unless it is missing or broken)

STEP 4

Place valve head with diaphragm kit back onto valve body. Before tightening the locking ring, make sure the strap wrench and locking ring are completely dry so that the strap wrench has the best grip possible on the locking ring. Tighten locking ring back to original position with strap wrench (supplied) by turning clockwise.

STEP 5

Turn control stop back on by turning counter-clockwise using a flat head screw driver.

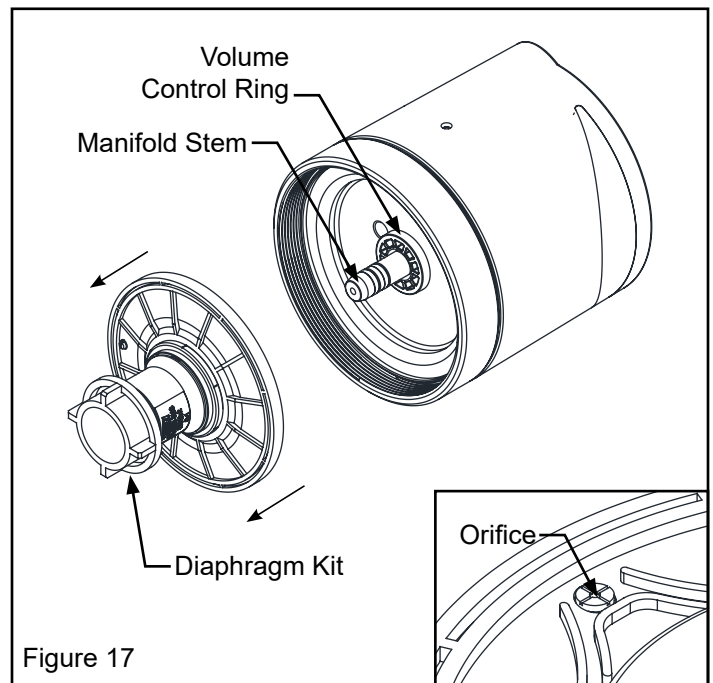

Figure 17

Retrofit Installation Instruction

STEP 1

Turn off control stop using a flat head screw driver turning clockwise. Then, use the electronic or manual override button or manual handle to flush the water out of the flush valve.

STEP 2

Remove the existing valve cap/head and diaphragm kit from the valve body to get the valve to either state shown in Figure 18A.

STEP 3

FOR ULF UNIVERSAL KIT ONLY: Loosen tailpiece nut from control stop and slide tailpiece out of control stop. Locate tailpiece tabs. If the valve body does not have tailpiece tabs matching those in Figure 18B, then carefully insert the tailpiece into the control stop, tighten the tailpiece nut, and proceed to Step 4.

If tailpiece tabs are present, then press the Flow Restrictor into the tailpiece, being sure to align the tabs with the pockets on the Flow Restrictor. Carefully insert the tailpiece into the control stop and tighten the tailpiece nut.

STEP 4

Ensure the Volume Control Ring is installed on the manifold stem. Slide the diaphragm kit into the valve body, orienting the orifice opposite of the control stop. See Figure 18C.

STEP 5

Install valve head and diaphragm kit onto the valve body. Rotate the valve head so the sensor window is facing outward. See Sensor Angle Adjustment section if more detail is needed.

STEP 6

Before tightening the locking ring, make sure the strap wrench and locking ring are completely dry so that the strap wrench has the best grip possible on the locking ring.

Hand tighten the locking ring onto the valve body. If the locking ring will not thread onto the valve body go to the Locking Ring Change Section. Finish tightening the locking ring using the strap wrench. Turn the locking ring at least 1/3 of a turn with the strap wrench.

STEP 7 (if applicable)

Remove the Manual Handle. Place the Handle Cap Seal in the Handle Cap and torque the handle cap in place.

STEP 8

Slowly turn on the control stop using a flat head screw driver turning counter-clockwise and check for leaks. If leaks occur, tighten locking ring further. Go to Battery Installation section to power on the unit and check for leaks once more after flushing the valve. If you find leaks are still present. Then remove the valve cap from the valve head shown in Step 4.1 & 4.2 of the Battery Installation Section. Use the supplied strap wrench or a large wrench on the flats of the locking ring to tighten it.

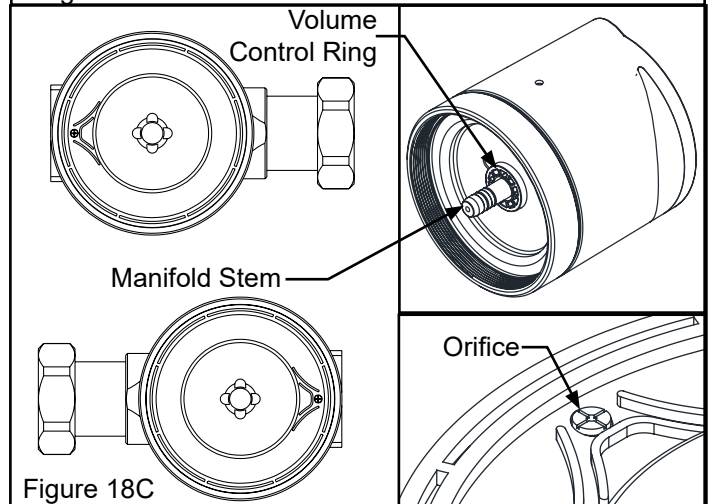
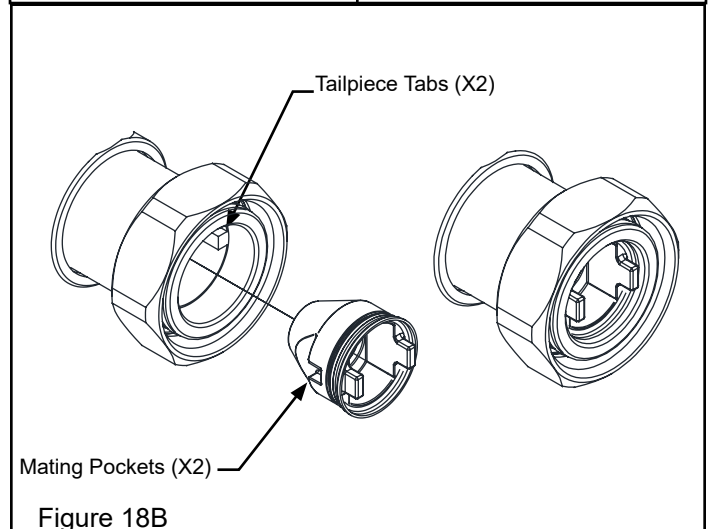
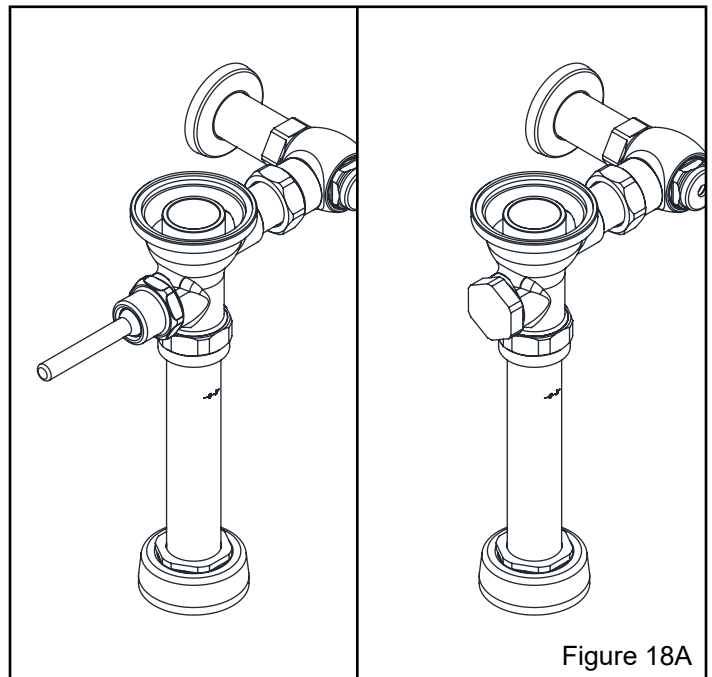

Locking Ring Change Instruction

STEP 1

Take the additional locking ring from the retrofit kit box and thread it onto the valve body to ensure the threads match. If the additional locking ring will not thread onto the valve contact customer service for further instructions

STEP 2

Remove the diaphragm kit from the valve head if attached. Then remove the valve cap from the valve head following Steps 4.1 & 4.2 of the Battery Installation Section.

STEP 3

Using a Phillips head screwdriver, turning counter clockwise remove the 3 mounting screws shown in Figure 19 and remove the ring insert from the manifold. Then remove the existing locking ring from the manifold and install the new locking ring onto the manifold.

STEP 4

Install the removed ring insert and using a Phillips head screwdriver, turning clockwise tighten all 3 mounting screws. Reassemble the valve cap to the manifold assembly following Step 2 in reverse order.

STEP 5

Resume step 4 of the Retrofit Installation Section.

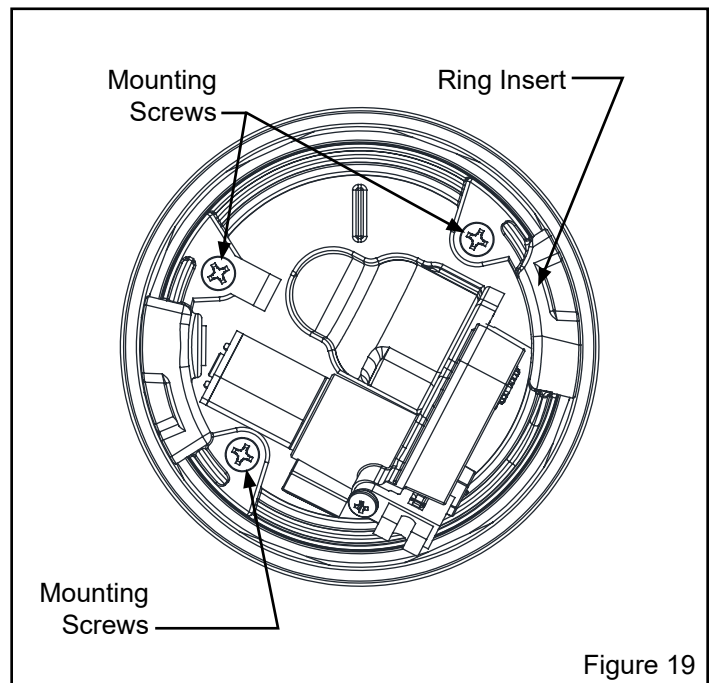

Sensor Range Adjustment (when necessary)

STEP 1

Place a piece of cardboard or a light-colored target at desired detection range away from sensor.

Note: When placing the target for a water closet consider that when standing at the front of the bowl the sensor is focused on the right upper thigh area.

STEP 2

Place the Zurn Magic Magnet (optional accessory: P6900-AT-MAG) on top flat surface (see Figure 20). Once magnet is placed in the general area shown, the red status LED illuminates continuously on for 5 seconds. The status LED will quickly flash and then begin flashing once a second. The valve will then have entered Calibration Mode and the magnet should be left in place to automatically enter verification mode at the end of calibration.

Note: The target must be in position no later than the end of the 2nd flash after the first quick flashes. The last 8 of 10 flashes will determine the new detection range.

STEP 3

After 10 LED flashes followed by a double flash the new detection range will be calibrated and set. If the Magnet was not removed the range verification mode will automatically commence.

STEP 4

During range verification mode repeatedly move the target away and toward the sensor. When the target is within range the status LED continuously illuminates. When the target is out of range the status LED turns off. If range is satisfactory remove the magnet and sensor resumes normal operation. If the range is not satisfactory remove the magnet and repeat sensor range adjustment at step 1

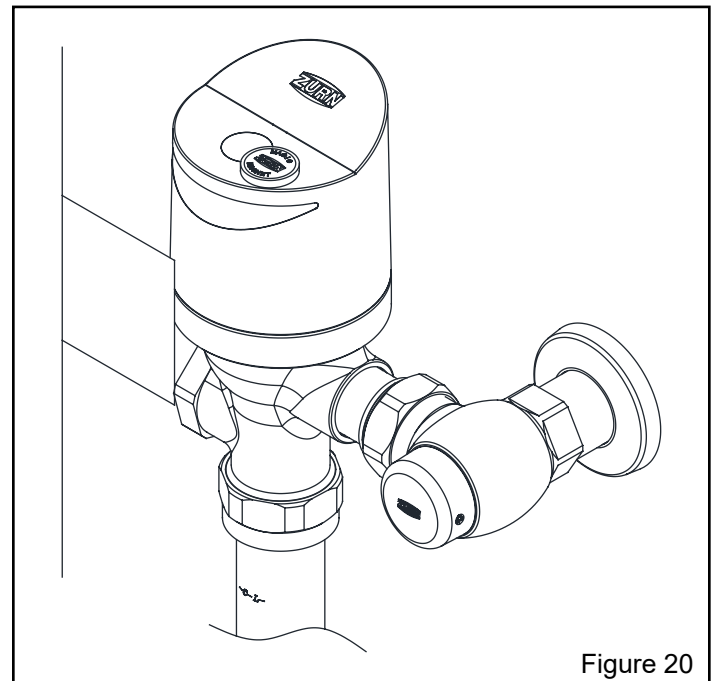

⚠ While in range verification mode, test calibrated sensor range using targets of various material types/textures to ensure calibration accuracy. Verify that sensor range does not detect stall doors or other reflective surfaces.

Courtesy Flush Settings (when necessary)

A courtesy flush can be enabled for the ZER-TM flushometer where the valve will automatically flush at a specified interval based on customer preference.

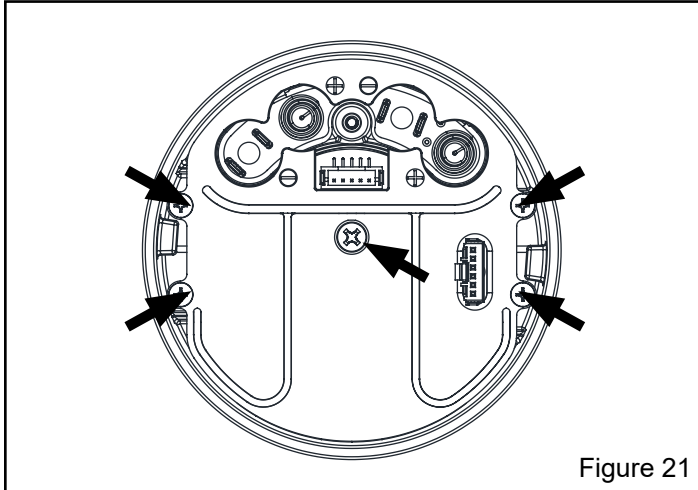

Figure 21

STEP 1

Reference Step 4 Battery installation section on page 6 to remove battery cap.

STEP 2

Remove 4 small screws on two sides and 1 long screw in the center (See figure 21) with cross head screwdriver.

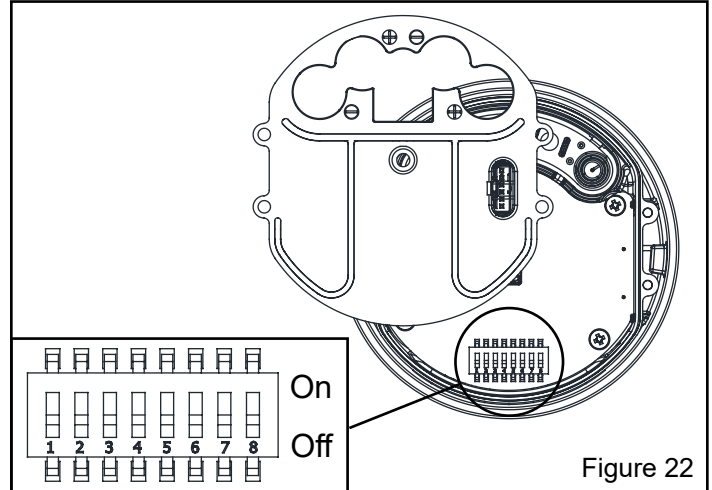

Figure 22

STEP 3

Detach electronic housing cover slowly without disconnect connector within electronic housing.

STEP 4

Manipulate DIP switches #2 and #3 (See table below) located inside the electronic housing to change the courtesy flush interval.

Courtesy Flush Interval	DIP switch #2	DIP switch #3
Disabled (Default Setting)	OFF	OFF
24 hours	OFF	ON
48 hours	ON	OFF
72 hours	ON	ON

Dual Flush User Guide (For ZER6000AV-DF-TM Only)

- The Dual Flush model supplies flush volumes of 1.1 and 1.6 gallons per flush. When a user is present for less than 60 seconds, the valve will flush with 1.1 gallons of water. When a user is present for over 60 seconds, the valve consumes 1.6 gallons of water. If the manual override button is pressed, the valve will always flush 1.6 gallons of water. A user must be present for a minimum of 8 seconds in order to trigger a flush.
- The Dual Flush model must be paired with a fixture with a flush volume range that includes 1.1 to 1.6 gallons per flush. For a list of recommended bowls, please refer to our website, www.zurn.com, or speak with your local Zurn rep.

Care and Cleaning Instruction

- Do not use any abrasive or chemical cleaners to clean the flushometer.
- The suggested cleaning of chrome plated surfaces is simply to clean them with mild soap and water, then dry. Commercial cleaning compounds are never recommended.
- Upon cleaning other areas of the restroom, be sure the sensor lenses are protected from other cleaning chemicals/solvents to prevent potential damages to the sensor and/or electronics.
- Valves used in installations subject to shut down because of cold and freezing conditions should be maintained in the following manner. After the main supply has been shut off and the water drained from the system, remove the stop valve cap and stop valve internals to allow the water to drain from the flush valve itself.

Trouble Shooting Guide

Problem	Indicator	Cause	Corrective Action	
Flush valve does not flush.	No water flushed.	Stop valve is closed	Open stop valve	
	Sensor flashes every half a second	Complete flush cycle not detected	Contact Customer Service for further instruction	
	No sensor light	Batteries not making contact	Remove and reinstall batteries correctly, or replace batteries. See Battery installation step 4 for reference.	
	Sensor flashes every 3 seconds	Critically low battery voltage indication		
	Sensor flashes every 10 seconds	Low battery voltage indication		
	Sensor flashes every 30 seconds	Continuous user detection of object within sensor range		
	Sensor detects user but fail to flush upon exiting sensor range	User/object still in sensor field		Identify and remove any user from sensor field
				Reduce sensor range distance (see Sensor Range Adjustment instructions)
		Battery power level too low to activate flush valve		Replace batteries. See Battery Installation step 4 for reference.
		Dirty sensor lens		Clean sensor lens with warm water and mild soap until free of debris
		Loose or damaged wire harness		Inspect wire harness and connection between electronics and motor
		User not detected.	Sensor range may need to be adjusted	
Flush valve is aimed at an angle.			Rotate flush valve head to be perpendicular to wall. See Sensor Angle Adjustment section for adjusting the flush valve head.	
Manual override button does not initiate a flush.	Battery power level too low to activate flush		Replace batteries. See Battery Installation for reference.	
Valve does not evacuate fixture	Insufficient volume of water to adequately siphon fixture.	Stop valve is not open enough.	Open stop valve for desired volume of water.	
		Insufficient volume or pressure at supply.	Increase incoming water supply pressure to minimum 25psi.	
	Valve shuts off too quickly or short flushes.	Damaged or punctured diaphragm.		Install new diaphragm replacement kit. (See Diaphragm Replacement and Cleaning Section for replacement instruction)
		Enlarged by-pass orifice.		Install new diaphragm replacement. (See Diaphragm Replacement and Cleaning Section for replacement instruction)
		Diaphragm kit is not matched to the fixture.		Install new diaphragm replacement kit. (See Diaphragm Replacement and Cleaning Section for replacement instruction)

Trouble Shooting Guide

Problem	Indicator	Cause	Corrective Action
Valve is flushing too long or not shutting off.	High water delivery or continuous flow.	By-pass orifice is plugged or partially plugged.	Examine by-pass orifice and clean if necessary being certain not to enlarge orifice opening. (See Diaphragm Replacement and Cleaning Section for cleaning instruction)
Water splashes out of fixture.	Water splashes onto floor during flush cycle.	Supply volume is too high.	Slowly close the control stop to lower water pressure.
		Mineral accumulation on vortex or spreader holes of fixture.	Remove the mineral build up.
Flush is not considered quiet.	Flush is loud.	Control stop may not be adjusted for quiet operation.	Adjust the control stop for quiet operation keeping in mind the fixture evacuation requirements.
		Fixture may be contributing to noise.	Check noise created by fixture by placing a cover over the bowl opening to separate valve noise from bowl noise. If it is determined the fixture is too noisy, consult with fixture manufacturer.
		Piping system may be source of noise.	High pressure in the system can sometimes be controlled by the stop valve. Other sources of noise may be the absence of air chambers and shock arrestors, loose pipes, improper size pipes, etc. In these cases, the building engineer should be consulted.
Valve leaking near valve head.	Water droplets seen between valve head and valve body.	Locking ring not tight.	Tighten locking ring. See Sensor Angle Adjustment section for reference.
Valve flushed with no user present	Valve flushed with no user present	Highly reflective environment	Re-calibrate sensor range - see Sensor Range Adjustment section
		Sensor range set too far; picking up other objects	
		Flush valve may be configured to exchange the water in the trap-way at every [24 / 48 / 72] hours after no usage (default is OFF).	See Courtesy Flush Settings step 4 for instructions on changing dipswitch settings to achieve desired trap exchange timing.

For further assistance with troubleshooting, visit <http://www.zurn.com/>

ZER-TM Series Repair Kits

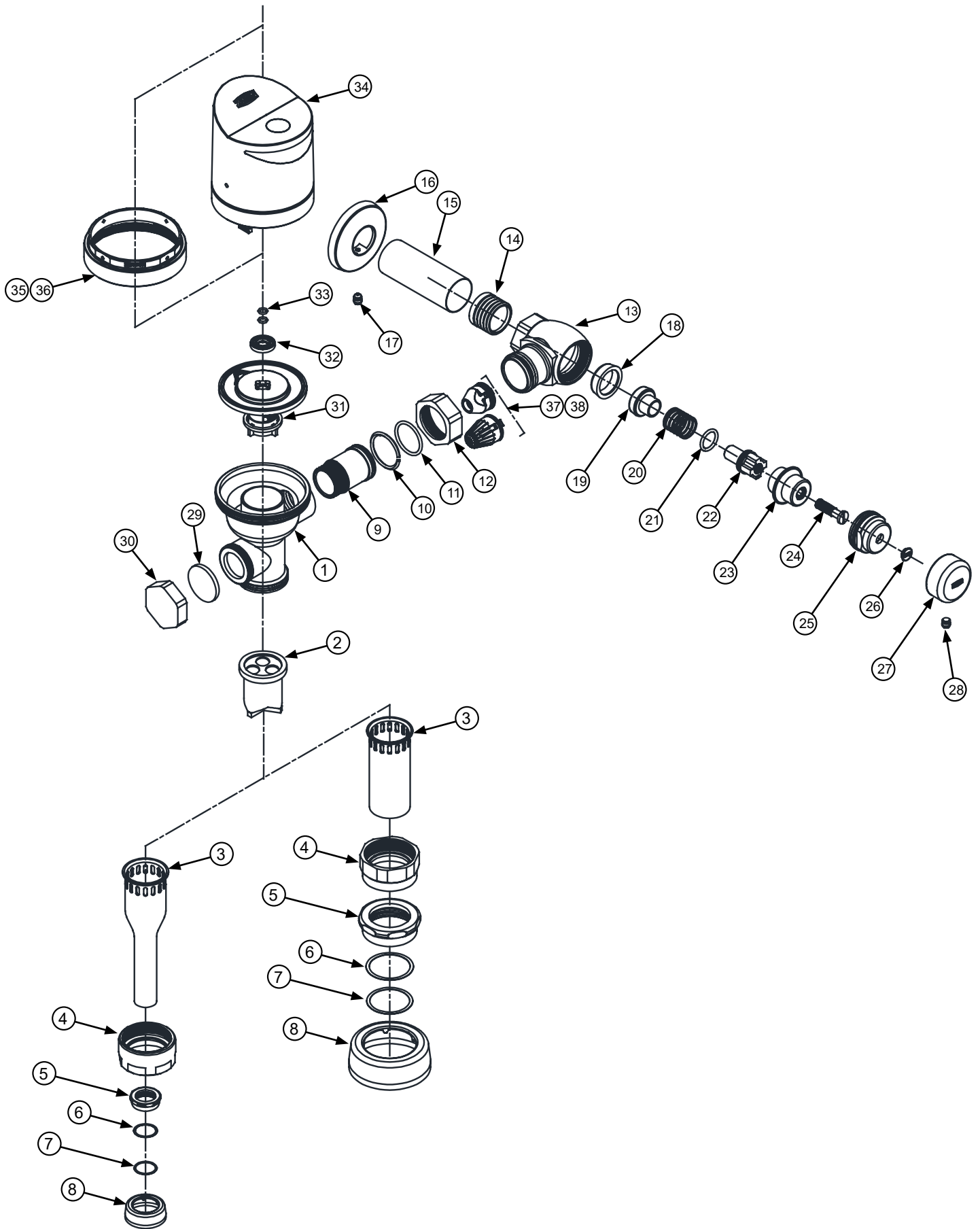

Part Identification

- | | | |
|----------------------------|---|--------------------------|
| 1. Valve Body | 16. Cast Wall Escutcheon | 31. Diaphragm Kit |
| 2. Vacuum Breaker Duckbill | 17. Setscrew for Cast Wall Flange | 32. Volume Control Ring |
| 3. Vacuum Breaker Tube | 18. Piston Seal | 33. Manifold Stem O-Ring |
| 4. Vacuum Breaker Tube Nut | 19. Piston | 34. ZER-TM Valve Head |
| 5. Spud Nut | 20. Stop Spring | 35. Locking Ring |
| 6. Spud Friction Washer | 21. Guide O-Ring | 36. Sloan Locking Ring |
| 7. Spud Sleeve | 22. Piston Guide | 37. Filter |
| 8. Spud Escutcheon | 23. Guide Holder | 38. Flow Restrictor |
| 9. Tailpiece | 24. Adjusting Screw | |
| 10. Snap Ring | 25. Stop Cap | |
| 11. Tailpiece O-Ring | 26. Snap Cap Screw Cover | |
| 12. Locking Nut | 27. Vandal Resistant Control Stop Cover | |
| 13. Stop Body | 28. Setscrew for Control Stop Cover | |
| 14. Sweat Solder Adapter | 29. Handle Cap Seal | |
| 15. Supply Cover Tube | 30. Handle Nut | |

Service Parts

Control Stop Repair Kit and Parts	Product No.
Control Stop Repair Kit for 1" and 3/4", Items 18-24	P6000-D-SD
Seal Seat for 1" and 3/4", Item 18	P6000-D42
VP Control Stop Repair Kit for 1" and 3/4", Items 18-24	P6000-D-VP
Sweat Solder Connection with Cast Wall Flange, Items 14-16	P6000-YBYC

Adjustable Tailpieces	Product No.
Adjustable Tailpiece for Standard Flush Valve, Items 9-11	P6000-J1
Tailpiece Coupling Assembly, Items 10-12	P6000-K
Tailpiece Locking Ring, Item 10	P6000-C30
Tailpiece O-Ring, Item 11	P6000-C31
Coupling Nut, Item 12	P6000-C32
Filter, (Full Valve Only), Item 37	P6000-FA
Flow Restrictor, (Universal ULF PERK6203-FA Kit Only), Item 38	PERK6203-FA

Flush Connections and Spud Coupling Kits	Product No.
Vacuum Breaker Repair Kit, Item 2	P6000-B
Spud Coupling Assembly for Water Closet, Items 5-8. Specify size.	P6000-H
Spud Coupling Assembly for Urinal, Items 5-8. Specify size.	P6003-H

ZER-TM Valve Head Repair Kit and Parts	Product No.
Locking Ring, Item 35	PER6000-M-RING
Sloan Locking Ring, Item 36	PER6000-M-RING-S
Valve Head, (1.1 gpf), Item 34	PERK6000-L-1.1
Valve Head, (1.28 gpf), Item 34	PERK6000-L-1.28
Valve Head, (1.6 gpf), Item 34	PERK6000-L-1.6
Valve Head, (1.6/1.1 gpf), Item 34	PERK6000-L-1.6/1.1
Valve Head, (0.125gpf), Item 34	PERK6003-L-0.125
Valve Head, (0.5 gpf), Item 34	PERK6003-L-0.5
Valve Head, (1.0 gpf), Item 34	PERK6003-L-1.0
Valve Head for Sloan, (1.1 gpf), Item 34	PERK6000-L-1.1-S
Valve Head for Sloan, (1.28 gpf), Item 34	PERK6000-L-1.28-S
Valve Head for Sloan, (1.6 gpf), Item 34	PERK6000-L-1.6-S
Valve Head for Sloan, (1.6/1.1 gpf), Item 34	PERK6000-L-1.6/1.1-S
Valve Head for Sloan, (0.125 gpf), Item 34	PERK6003-L-0.125-S
Valve Head for Sloan, (0.5 gpf), Item 34	PERK6003-L-0.5-S
Valve Head for Sloan, (1.0 gpf), Item 34	PERK6003-L-1.0-S

ZER-TM Diaphragm Repair Kit	Product No.
Closet Repair Kit - (1.1, 1.28, 1.6, 1.6/1.1 gpf), Item 31-33	PER6000-EC
Urinal Repair Kit - (0.125 gpf), Item 31-33	PER6003-EU-ULF
Urinal Repair Kit - (0.5, 1.0 gpf), Item 31-33	PER6003-EU

