



Hydro•X Power®

ZER-HYD Series

Hydro•X Power Gear-Driven Flush Valves for Water Closets and Urinals

Installation, Operation, and Maintenance Manual



Water Closet Models:

ZER6000AV-ONE-HYD	1.1 gpf
ZER6000AV-HET-HYD	1.28 gpf
ZER6000AV-WS1-HYD	1.6 gpf
ZER6000AV-WS1-DF-HYD	1.1/1.6 gpf
ZER6000AV-HET-DF-HYD	1.1/1.28 gpf

Urinal Models:

ZER6003AV-ULF-HYD	0.125 gpf
ZER6003AV-EWS-HYD	0.5 gpf
ZER6003AV-WS1-HYD	1.0 gpf

⚠ WARNING: Cancer and Reproductive Harm - www.P65Warnings.ca.gov

⚠ ADVERTENCIA: Cáncer y daño reproductivo - www.P65Warnings.ca.gov

⚠ AVERTISSEMENT: Cancer et effets néfastes sur la reproduction - www.P65Warnings.ca.gov

LIMITED WARRANTY

All goods sold hereunder are warranted to be free from defects in material and factory workmanship for a period of three years from the date of purchase. Decorative finishes warranted for one year. We will replace at no costs goods that prove defective provided we are notified in writing of such defect and the goods are returned to us prepaid at Sanford, NC, with evidence that they have been properly maintained and used in accordance with instructions. We shall not be responsible for any labor charges or any loss, injury or damages whatsoever, including incidental or consequential damages. The sole and exclusive remedy shall be limited to the replacement of the defective goods. Before installation and use, the purchaser shall determine the suitability of the product for his intended use and the purchaser assumes all risk and liability whatever in connection therewith. Where permitted by law, the implied warranty of merchantability is expressly excluded. If the products sold hereunder are "consumer products," the implied warranty of merchantability is limited to a period of three years and shall be limited solely to the replacement of the defective goods. All weights stated in our catalogs and lists are approximate and are not guaranteed.

NOTICE: READ ENTIRE MANUAL PRIOR TO INSTALLING PRODUCT

AVIS : LIRE L'ENSEMBLE DU MANUEL AVANT D'INSTALLER LE PRODUIT

Specifications

Sensor Range	12" to 60"
Voltage	3.12V Lithium Ion (Primary), 3.2V Alkaline (Backup)
Operating Water Pressure	25 psi (Running) to 80 psi (Static)
Operating Water Temperature	35 deg. F to 104 deg. F

Important Safety Information

- Do not convert or modify this Zurn product. All warranties will be voided.
- All plumbing is to be installed in accordance with applicable codes and regulations.
- Water supply lines must be sized to provide an adequate volume of water for each fixture.
- Flush all water lines prior to making connections.
- Do not use pipe sealant or plumbing grease on any fitting other than the control stop inlet.
- Sensor units should not be located across from each other or in close proximity to highly reflective surfaces.
- Control stop should never be opened to allow flow greater than fixture is capable of evacuating. In the event of valve failure, fixture must be able to handle a continuous flow.

Prior to Installation

Before installing your flush valve, the items listed below should already be installed on-site:

- Water closet or urinal fixture
- Fixture carrier
- Drain line
- Water supply line

Package Contents

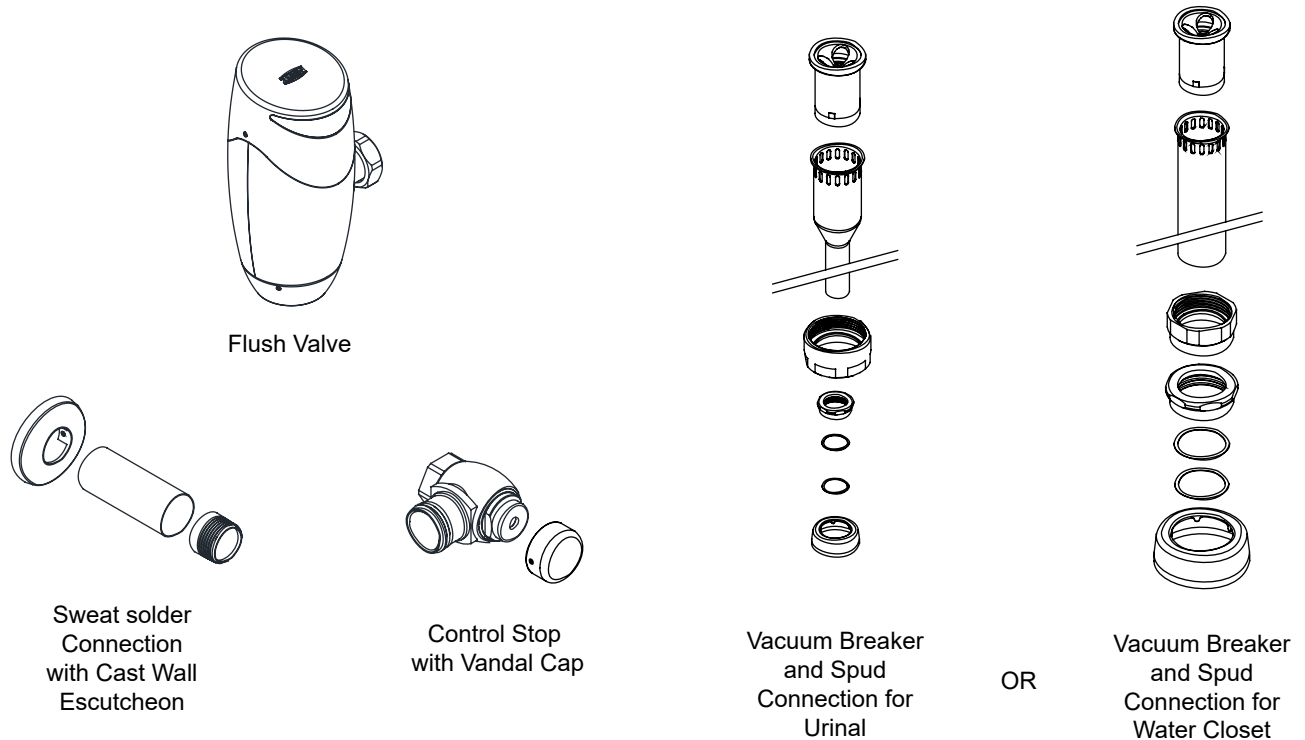

Required Tools

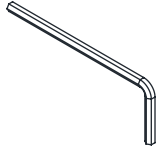

3/32", 5/64"
Hex Key
(Supplied)

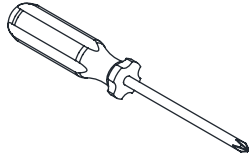

Phillips Head
Screwdriver

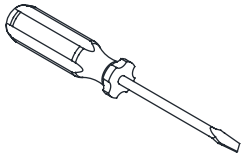

Flat Head
Screwdriver

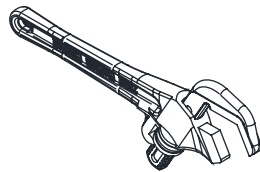

Smooth Jawed
Wrench

Optional Accessories

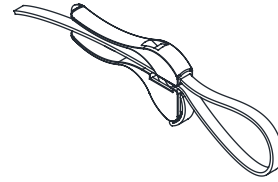

Strap Wrench



Magic Magnet
(P6900-AT-MAG)

Sweat Solder Adapter Installation

NOTE: Before installation, turn off the water supply to the fixture and remove flushometer if replacing an existing device.

1. Measure the distance from finished wall to the center line of the fixture spud. Cut the water supply pipe 1-1/4" shorter than this measurement.

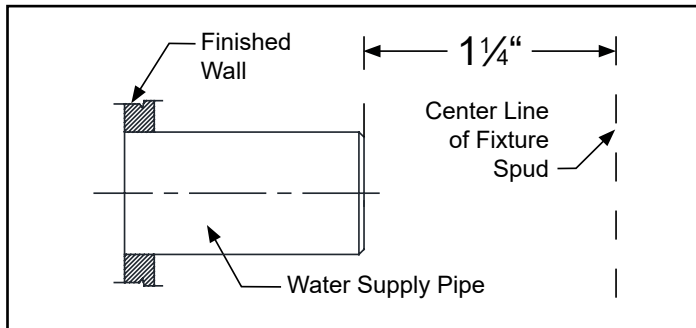

2. Slide the threaded sweat solder adapter onto the water supply pipe. Sweat solder the adapter to water supply pipe.

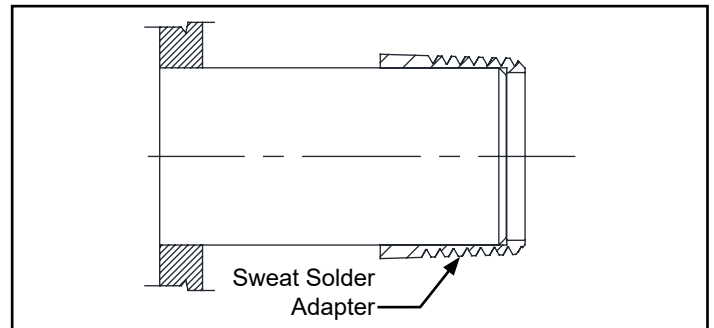

3. Measure the distance from finished wall to first thread of sweat solder adapter. Cut the cover tube to this length.

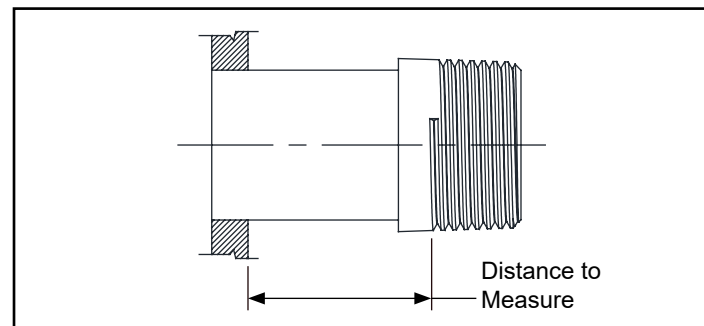

4. Slide the wall escutcheon over chrome cover tube and slide both over the water supply pipe. Press the wall escutcheon flush against finished wall and tighten the set screw with the hex key.

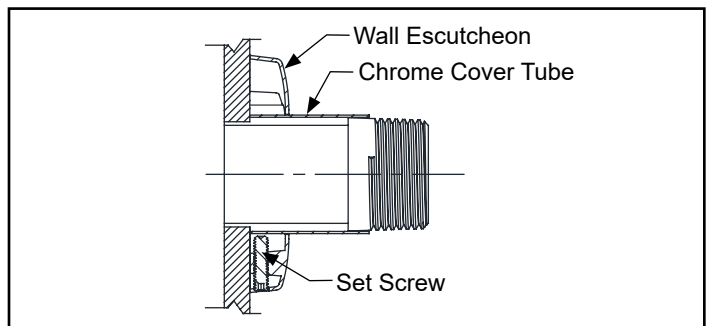

Control Stop Installation

1. Apply sealing compound and thread the control stop onto the supply adapter and tighten it with a smooth-jawed wrench.

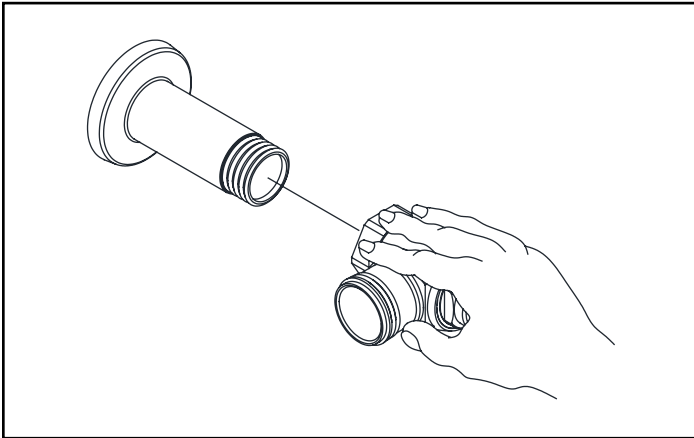

2. Open the control stop using a flathead screwdriver. Flush approximately 2 gallons to clear any debris from the line.

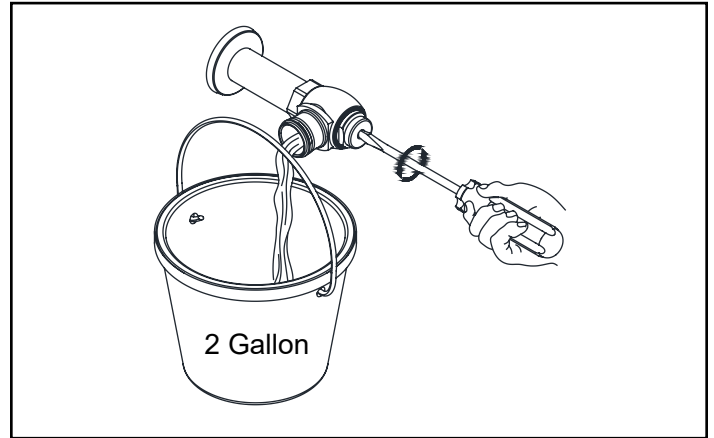

Flush Valve Installation

1. Insert the flush valve tailpiece into the control stop. Make sure the tailpiece o-ring is not pinched in the process. Lubricate the tailpiece o-ring with water if necessary.

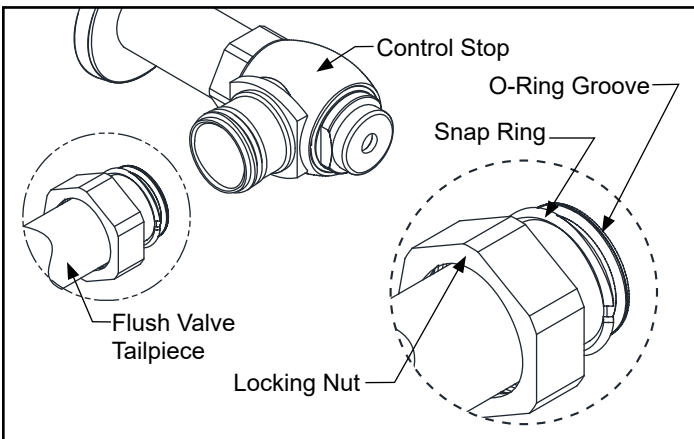

2. Loosen the set screws through two small holes on the shroud escutcheon by turning them counter-clockwise. Lower the shroud escutcheon from the valve body.

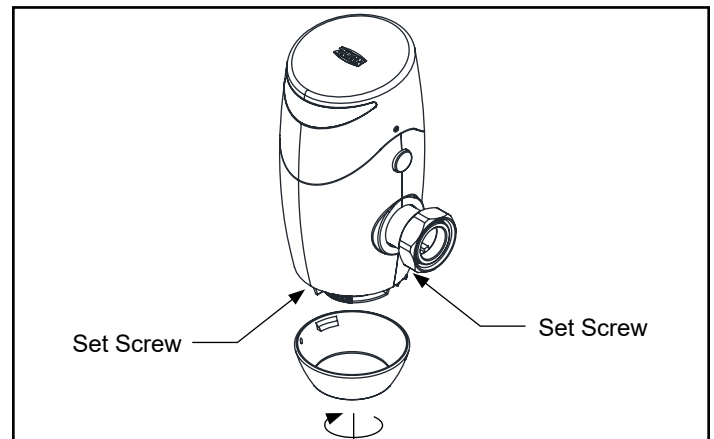

3. Determine the length of vacuum breaker tube required to join the flush valve and fixture spud and cut if necessary. **DO NOT** cut vacuum breaker tube shorter than 6" (below the -C-L- indicator mark).

4. Slide the tube nut, spud nut, slip gasket, rubber gasket, spud escutcheon and shroud escutcheon over the vacuum breaker tube and insert the tube into fixture spud. Hand tighten tube nut to valve body and the spud nut onto fixture spud. Fully tighten with smooth-jawed wrench.

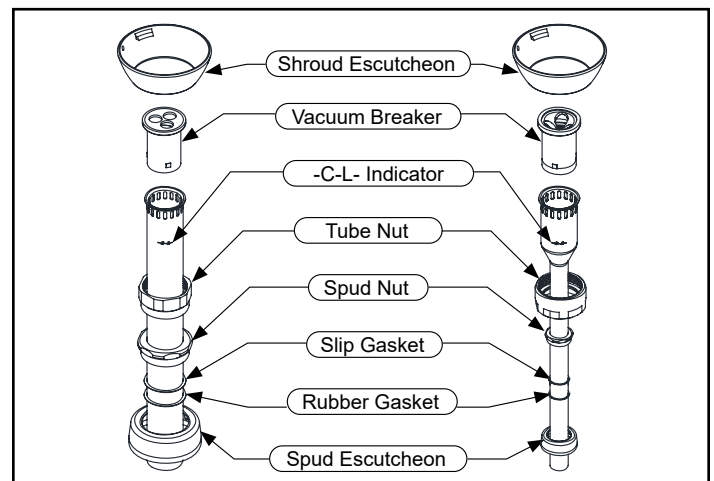

Backup Battery Installation

1. Remove the valve head by turning both set screws through the small holes in the side of the valve head counterclockwise with the 3/32" hex key. Lift the valve head off of the body.

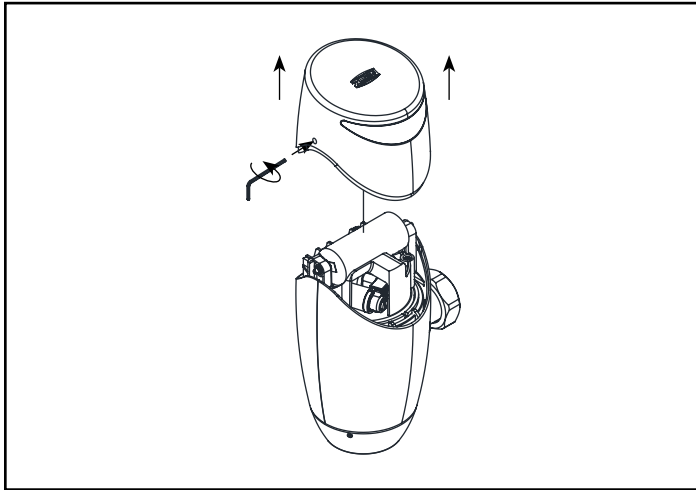

2. Insert the 2 AA backup Alkaline batteries into the battery tray.

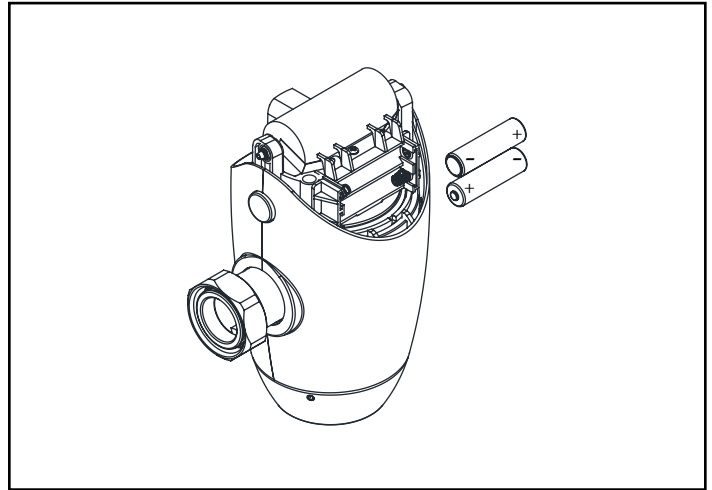

Valve Head and Wire Harness Installation

1. Identify the correct orientation for the valve head. This will depend on whether the control stop is installed on the left or right side of the valve. The correct orientation will result in the sensor lens facing the user.

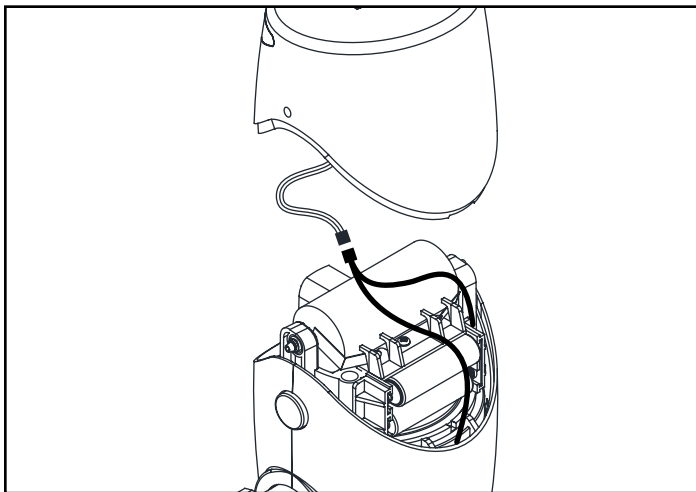

2. For installations where the control stop is installed on the left side of the valve, lay the wire harness flat over the rechargeable battery. Place the valve head over the body and re-tighten the set screws to secure it. Open the control stop to turn on the water.

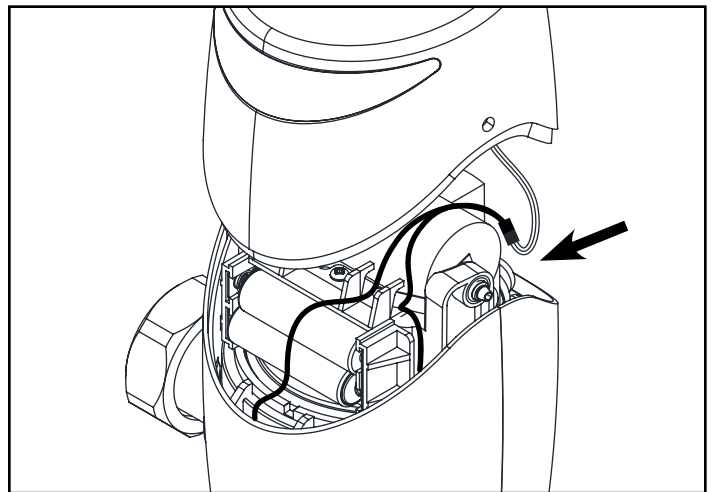

Care and Cleaning Instructions

- Do not use any abrasive or harsh chemical cleaners to clean the flushometer.
- Simply to clean chrome plated surfaces them with mild soap and water, then dry
- Valves installed in environments subject to shut down due to cold and freezing conditions should be maintained in the following manner: After the main supply has been shut off and the water drained from the system, remove the stop valve cap and stop valve internals to allow the water to drain from the flush valve itself.

Dual Flush User Guide (For -DF Models Only)

- The Dual Flush model supplies a high volume and low volume flush. When a user is present for less than 60 seconds, the valve will flush with 1.1 gallons of water. When a user is present for over 60 seconds, the valve consumes 1.6 or 1.28 gallons of water, depending on the model.
- The Dual Flush model must be paired with a fixture with a flush volume range that covers both volumes. For a list of recommended bowls, please refer to our website, www.zurn.com, or speak with your local Zurn rep.

Diaphragm Kit Replacement

1. If present, remove the control stop cover with the 3/32" hex key. Turn the control stop clockwise with a flat head screwdriver to turn off the water. Press the MOB to verify it has been turned off.

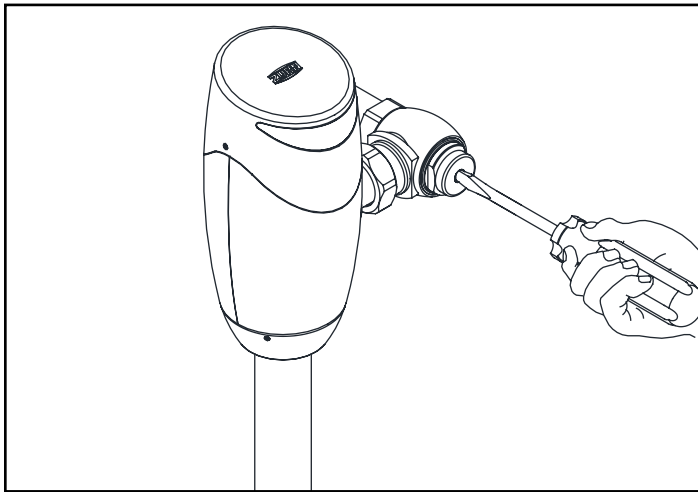

2. Loosen the set screws through two small holes in the shroud escutcheon by turning them counter-clockwise. Twist and lower the shroud escutcheon from the valve body.

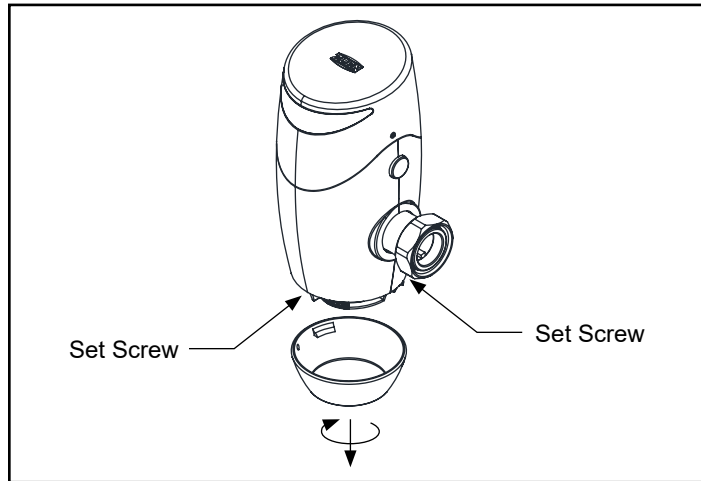

3. Remove the valve head by turning both set screws through the small holes in the side of the valve head counterclockwise with the 3/32" hex key. Lift the valve head off of the body and disconnect the wire harness

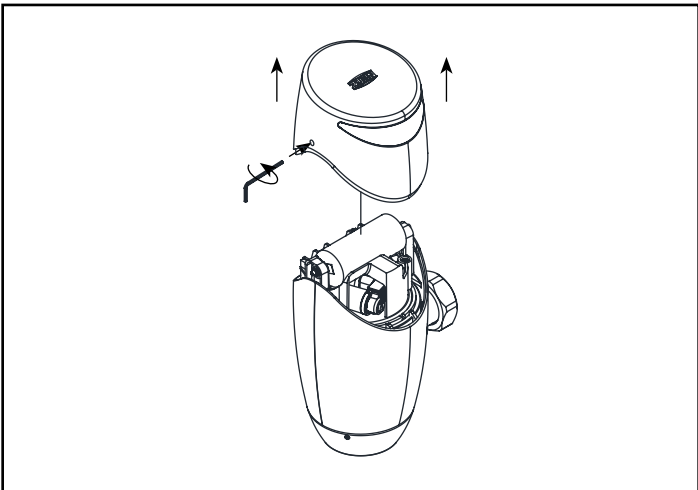

4. Locate the small screws holding the two halves of the shroud together and remove them. Remove the shrouds from the valve body.

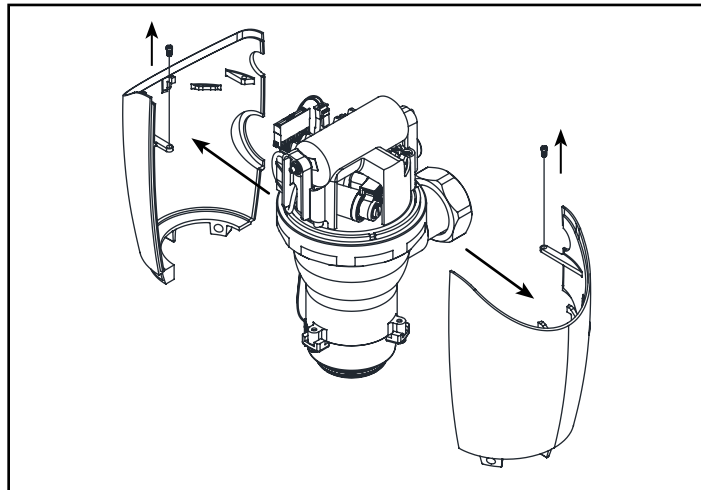

5. Loosen the locking ring by turning it counterclockwise with a strap wrench. Remove the manifold assembly from the lower valve assembly.

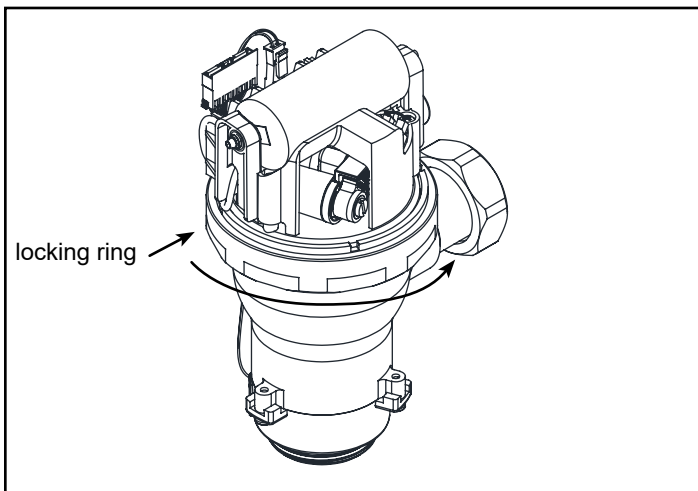

6. Remove and replace the diaphragm kit and the manifold stem o-rings. Reverse the process to re-assemble.

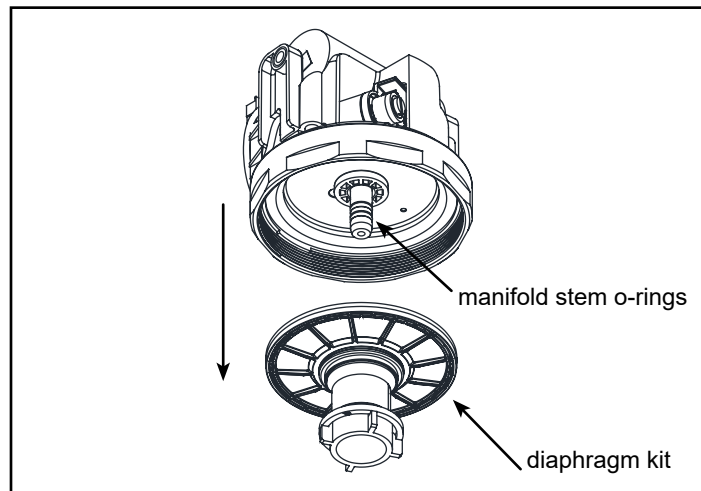

Sensor Range Adjustments

Each Hydro X Power flush valve sensor is calibrated at the factory. However, in situations where there is low light or high reflectivity, it might be necessary to adjust to the calibration distance. This can be done using a Zurn Magic Magnet following the steps below:

1. Stand at the desired the calibration distance:
 - ~28" from the sensor in a water closet application.
 - ~22" from the sensor in a urinal application.
2. Place a Magic Magnet on the right side of the lens within indicated area and hold until the user LED lights up
3. Hold the Magic Magnet in this position until the user LED beings to blink and remove it. After 10 blinks, a rapid double-blink will indicate that the re-calibration is complete.
4. Step away from the unit for 5 seconds and return to the same position. If the user LED blinks, the new calibration distance has been susccesfully set. Note that for water closet applications, re-calibrating to too far from the sensor can result in the sensor detecing the stall door. Check for this by making sure the valve does not flush when the door is opened after being closed for 15 seconds.

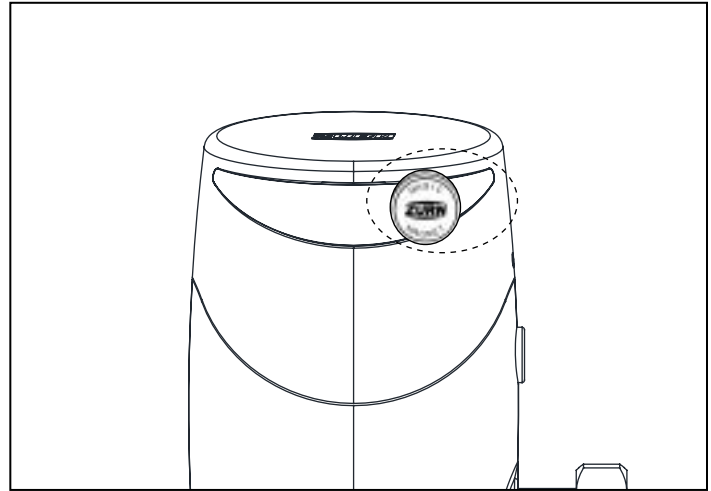

Custom Setting Adjustments

1. Remove the valve head by turning both set screws through the small holes in the side of the valve head counterclockwise with the 3/32" hex key. Lift the valve head off of the body and disconnect the wire harness

2. Remove the electronics access cover located on the underside of the electronics housing to reveal the DIP switches.

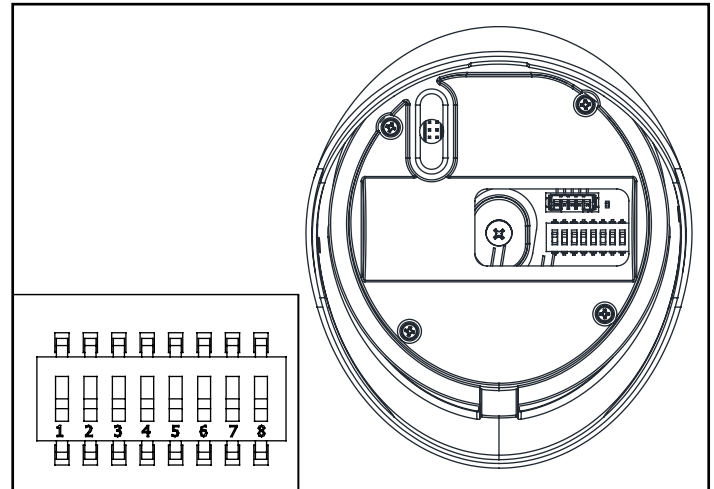
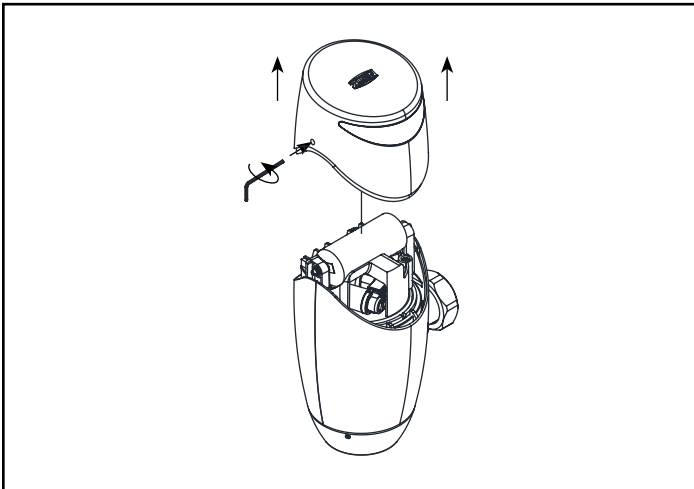

3. Adjust the courtesy flush interval by manipulating DIP switches #2 and #3 according to the table provided below:

4. Toggle the low/missing battery detection function by manipulating DIP switches #8 according to the table below:

Courtesy Flush Interval	DIP switch #2	DIP switch #3
Disabled (Default Setting)	OFF	OFF
24 hours	OFF	ON
48 hours	ON	OFF
72 hours	ON	ON

Battery detection	DIP switch #8
Enabled (Default Setting)	OFF
Disabled	ON

5. Reinstall the electronics access cover and position the wire harness in a vacant area over the battery tray. Reverse the earlier steps to re-assemble.

Troubleshooting Guide

Problem	Indicator	Cause	Corrective Action
Flush valve does not flush.	No water flushed.	Stop valve is closed	Open stop valve
	Sensor flashes 5 times in quick succession	Flush cycle did not complete	Contact Customer Service for further instruction
	No sensor light	Batteries not making contact	Remove and reinstall batteries correctly, or replace batteries. See Battery installation for reference.
		Critically low battery voltage	
	Sensor flashes once every 5 seconds	Low battery voltage indication	
	Sensor flashes every 30 seconds	Continuous user detection of object within sensor range	Recalibrate. See Sensor Range adjustment section for reference.
	Sensor flashes rapidly	Battery Powered: Batteries installed incorrectly.	Remove and reinstall batteries correctly. See Battery installation for reference.
	Sensor detects user, three slow flashes & two quick flashes, but fail to flush upon exiting sensor range	User/object still in sensor field	Identify and remove any user from sensor field
			Reduce sensor range distance (see Sensor Range Adjustment instructions)
		Battery power level too low to activate flush valve	Replace batteries. See Battery Installation for reference.
		Dirty sensor lens	Clean sensor lens with warm water and mild soap until free of debris
		Loose or damaged wire harness	Inspect wire harness and connection between electronics and motor
	User not detected; no LED flashes.	Sensor range may need to be adjusted	Increase sensor range distance (see Sensor Range Adjustment instructions)
Manual override button does not initiate a flush.	Stop valve is closed / turned off.	Turn on stop valve.	
	MOB does not depress	Contact Customer Service.	
Valve does not evacuate fixture	Insufficient volume of water to adequately siphon fixture.	Stop valve is not open enough.	Open stop valve for desired volume of water.
		Insufficient volume or pressure at supply.	Increase incoming water supply pressure to minimum 25psi.
		Insufficient volume for installed fixture	Contact Customer Service.
	Valve shuts off too quickly or short flushes.	Damaged or punctured diaphragm.	Install new diaphragm replacement kit. (See Diaphragm Replacement and Cleaning Section for replacement instruction)
		Enlarged by-pass orifice.	Install new diaphragm replacement. (See Diaphragm Replacement and Cleaning Section for replacement instruction)
		Diaphragm kit is not matched to the fixture.	Install new diaphragm replacement kit. (See Diaphragm Replacement and Cleaning Section for replacement instruction)

Troubleshooting Guide

Problem	Indicator	Cause	Corrective Action
Valve is flushing too long or not shutting off.	High water delivery or continuous flow.	By-pass orifice is plugged or partially plugged.	Examine by-pass orifice and clean if necessary being certain not to enlarge orifice opening. (See Diaphragm Replacement and Cleaning Section for cleaning instruction)
Water splashes out of fixture.	Water splashes onto floor during flush cycle.	Supply volume is too high.	Slowly close the control stop to lower water pressure.
		Mineral accumulation on vortex or spreader holes of fixture.	Remove the mineral build up.
Flush is not considered quiet.	Flush is loud.	Control stop may not be adjusted for quiet operation.	Adjust the control stop for quiet operation keeping in mind the fixture evacuation requirements.
		Fixture may be contributing to noise.	Check noise created by fixture by placing a cover over the bowl opening to separate valve noise from bowl noise. If it is determined the fixture is too noisy, consult with fixture manufacturer.
		Piping system may be source of noise.	High pressure in the system can sometimes be controlled by the stop valve. Other sources of noise may be the absence of air chambers and shock arrestors, loose pipes, improper size pipes, etc. In these cases, the building engineer should be consulted.
Valve leaking near valve head.	Water droplets seen between valve head and valve body.	Locking ring not tight.	Tighten locking ring. See Sensor Angle Adjustment section for reference.
Valve flushed with no user present	Valve flushed with no user present	Highly reflective environment	Re-calibrate sensor range - see Sensor Range Adjustment section
		Sensor range set too far; picking up other objects	
		Flush valve may be configured to exchange the water in the trap-way at every [24 / 48 / 72] hours after no usage (default is OFF).	See Courtesy Flush Battery Detection Settings for instructions on changing dipswitch settings to achieve desired trap exchange timing.

Repair Parts and Kits

Item List:

1. Valve body
2. Shroud escutcheon
3. Duckbill
4. Vacuum breaker tube nut
5. Vacuum breaker tube (water closet)
6. Spud nut (water closet)
7. Spud friction washer (water closet)
8. Spud gasket (water closet)
9. Spud escutcheon (water closet)
10. Vacuum breaker tube (urinal)
11. Spud nut (urinal)
12. Spud friction washer (urinal)
13. Spud gasket (urinal)
14. Spud escutcheon (urinal)
15. Diaphragm kit

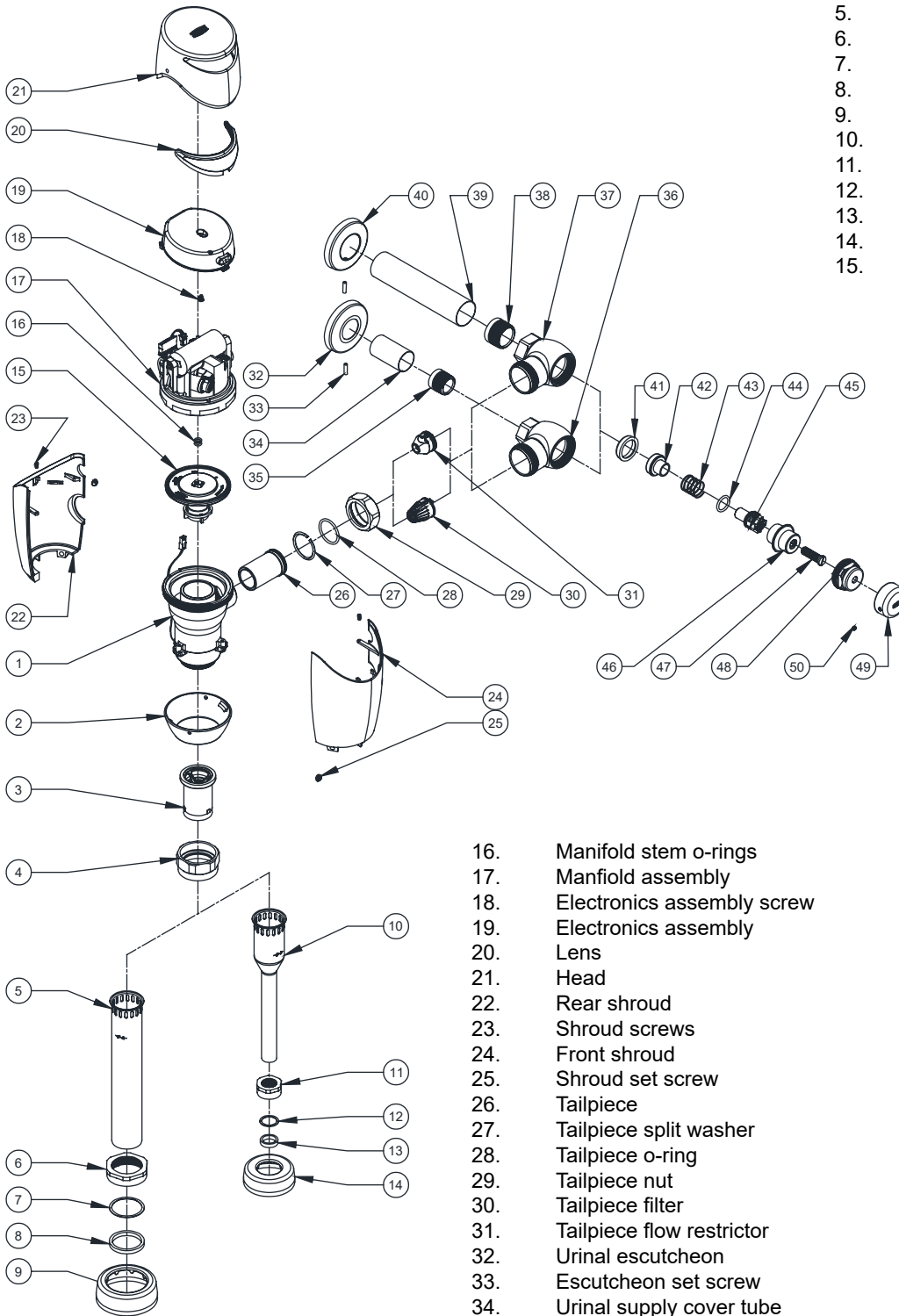

- | | |
|---------------------------------|---------------------------------------|
| 16. Manifold stem o-rings | 36. Urinal stop valve |
| 17. Manifold assembly | 37. Water closet stop valve |
| 18. Electronics assembly screw | 38. Water closet sweat solder adapter |
| 19. Electronics assembly | 39. Water closet supply cover tube |
| 20. Lens | 40. Water closet escutcheon |
| 21. Head | 41. Piston seal |
| 22. Rear shroud | 42. Piston |
| 23. Shroud screws | 43. Spring |
| 24. Front shroud | 44. Guide o-ring |
| 25. Shroud set screw | 45. Guide |
| 26. Tailpiece | 46. Guide holder |
| 27. Tailpiece split washer | 47. Adjusting screw |
| 28. Tailpiece o-ring | 48. Stop cap |
| 29. Tailpiece nut | 49. Stop cover |
| 30. Tailpiece filter | 50. Stop cover set screw |
| 31. Tailpiece flow restrictor | |
| 32. Urinal escutcheon | |
| 33. Escutcheon set screw | |
| 34. Urinal supply cover tube | |
| 35. Urinal sweat solder adapter | |

Repair Kits

Control Stop and Sweat Adapter

Description	Item(s)	SKU
Piston Seal	41	P6000-D42
Control Stop Kit	41-47	P6000-D-SD
1" Supply Kit	33, 38-40	P6000-YBYC
3/4" Supply Kit	32-35	P6003-YBYC

Tailpiece

Description	Item(s)	SKU
Tailpiece Assembly	26-28	P6000-J1
Tailpiece Coupling Assembly	27-29	P6000-K
Snap Clip	27	P6000-C30
O-Ring	28	P6000-C31
Locking Nut	29	P6000-C32-CP
Tailpiece Filter	30	P6000-FA
Tailpiece Flow Regulator for Urinals	31	PERK6203-FA

Vacuum Breaker and Spud Connection

Description	Item(s)	SKU
Vacuum Breaker	3	P6000-B-HP
Vacuum Breaker Tube Kit for Water Closets	3-5	P6000-A-AA-CP
Vacuum Breaker Tube Kit for Urinals	3, 4, 10	P6003-A-AA-CP
Spud Coupling Assembly for Water Closets	6-9	P6000-H
Spud Coupling Assembly for Urinals	11-14	P6003-H

Flush Valve

Description	Item(s)	SKU
Diaphragm Kit	15, 16, 23	PER6000-E-HYD
Head Kit	18-21	PER6000-L-HYD-CAP
Lens	20	PER6000-L-HYD-SL
Shroud Kit	2, 22-25	PER6000-L-HYD-SHDKIT
Magic Magnet (Not Included)	(Not Shown)	P6900-AT-MAG

