



AquaSense® AV ZEMS-IS Series

Automatic Sensor-Operated
Exposed Flushometer

Installation, Operation,
Maintenance, and Parts Manual

Patented and Patents Pending



AquaSense Hardwired
Flush Valves



ZEMS6000AV-IS



ZEMS6003AV-IS



Sensor-Operated Exposed Flushometer

ZEMS6000AV-IS Closet

ZEMS6003AV-IS Urinal

LIMITED WARRANTY

All goods sold hereunder are warranted to be free from defects in material and factory workmanship for a period of three years from the date of purchase. Decorative finishes warranted for one year. We will replace at no cost goods that prove defective provided we are notified in writing of such defect and the goods are returned to us prepaid at Sanford, NC, with evidence that they have been properly maintained and used in accordance with instructions. We shall not be responsible for any labor charges or any loss, injury or damages whatsoever, including incidental or consequential damages. The sole and exclusive remedy shall be limited to the replacement of the defective goods. Before installation and use, the purchaser shall determine the suitability of the product for his intended use and the purchaser assumes all risk and liability whatever in connection therewith. Where permitted by law, the implied warranty of merchantability is expressly excluded. If the products sold hereunder are "consumer products," the implied warranty of merchantability is limited to a period of three years and shall be limited solely to the replacement of the defective goods. All weights stated in our catalogs and lists are approximate and are not guaranteed.



Metroflush® Z6200 Series

Metroflush Piston-Operated
Flush Valve

Installation, Operation,
Maintenance, and Parts Manual

Patented and Patents Pending

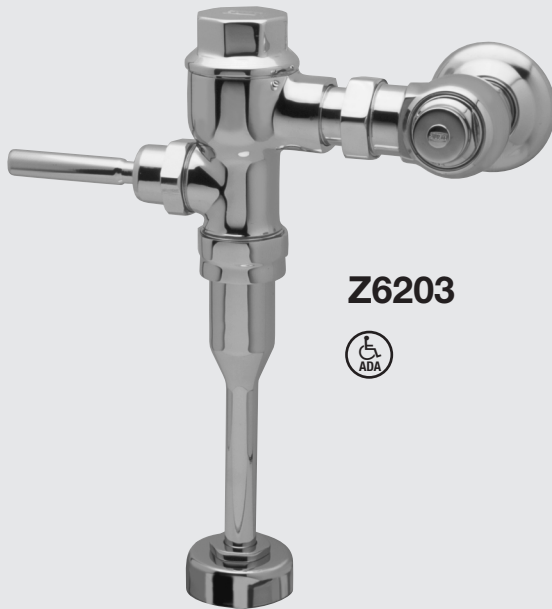

Z6203

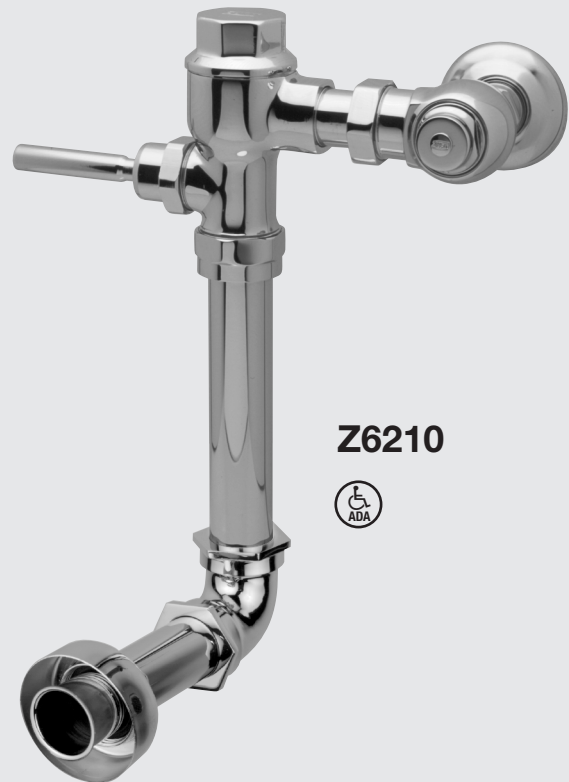

Z6210



**Metroflush
Piston-Operated Flush Valve**

Z6200

Z6201

Z6203

Z6210

Metroflush
Piston-Operated
Flush Valves

LIMITED WARRANTY

All goods sold hereunder are warranted to be free from defects in material and factory workmanship for a period of three years from the date of purchase. Decorative finishes warranted for one year. We will replace at no cost goods that prove defective provided we are notified in writing of such defect and the goods are returned to us prepaid at Sanford, NC, with evidence that they have been properly maintained and used in accordance with instructions. We shall not be responsible for any labor charges or any loss, injury or damages whatsoever, including incidental or consequential damages. The sole and exclusive remedy shall be limited to the replacement of the defective goods. Before installation and use, the purchaser shall determine the suitability of the product for his intended use and the purchaser assumes all risk and liability whatever in connection therewith. Where permitted by law, the implied warranty of merchantability is expressly excluded. If the products sold hereunder are "consumer products," the implied warranty of merchantability is limited to a period of three years and shall be limited solely to the replacement of the defective goods. All weights stated in our catalogs and lists are approximate and are not guaranteed.

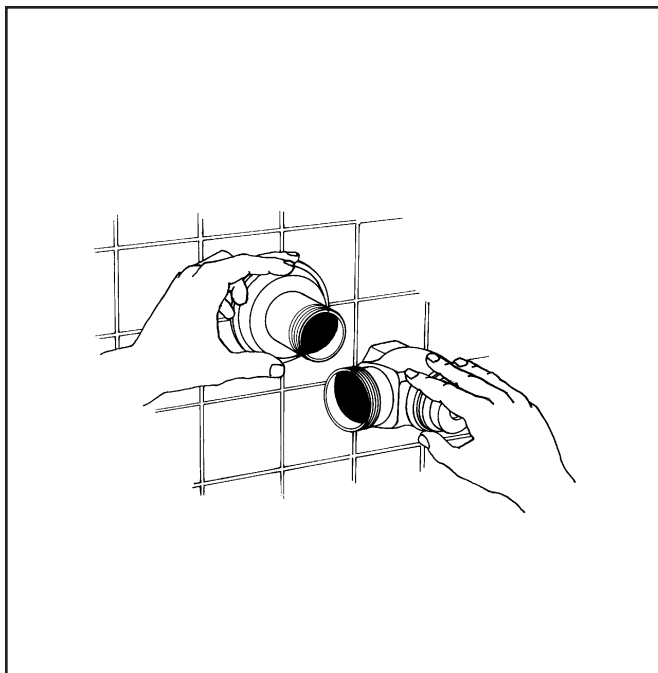

1 Install stop valve using proper supply escutcheon and sweat solder kit if applicable.

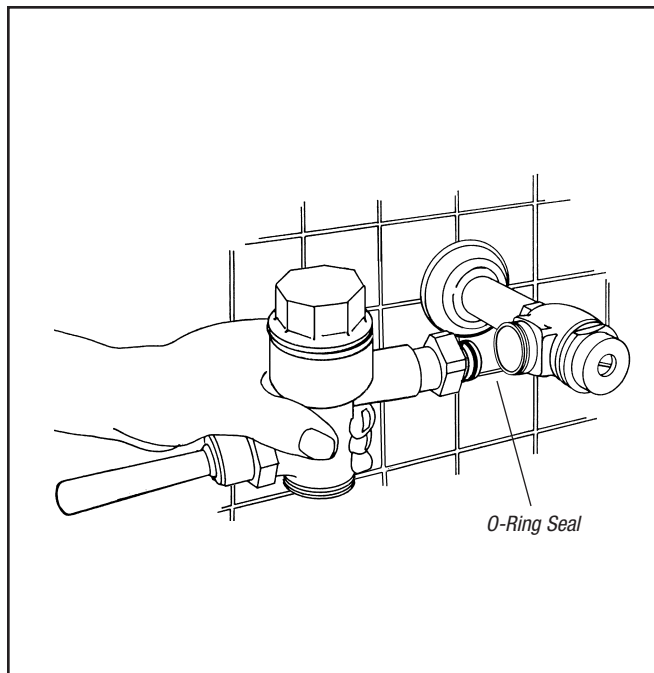

2 Insert flush valve tailpiece into stop valve, being certain O-ring seal is in place. Wet seal with water to lubricate. Hand tighten locknut. Determine length of vacuum breaker tube required and cut as necessary. Assemble vacuum breaker tube assembly between flush valve and fixture spud.

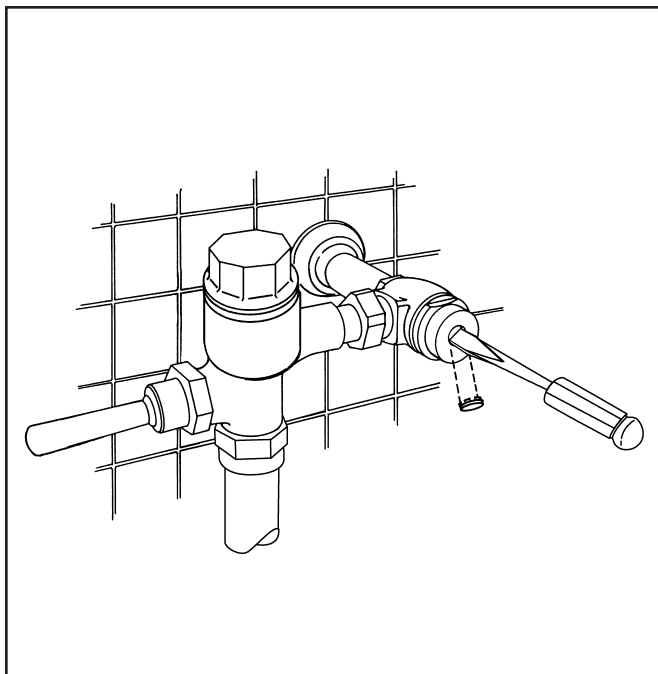

3 Flushing of supply lines by using the following procedure is recommended, after installation of all valves.

- Close stop valves by using adjusting screw behind adjusting screw cover. Do not remove stop valve cap.
- Remove main valve body cover and working part from flush valve.
- Replace only main valve body cover. Tighten main valve body cover.
- Open the stop valve, by using the adjusting screw, until debris is purged.
- Shut the stop valve, replace working part and retighten cover.

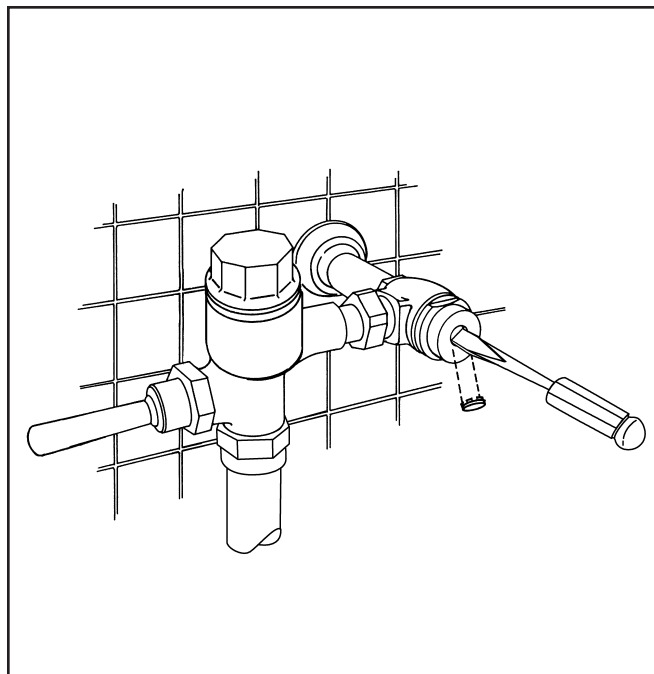

4 Set flush valve for proper operation by adjusting stop valve. Stop valve adjustments can only be made by using the adjusting screw located behind the adjusting screw cover. (Water must be shut off at main supply valve if stop cap is to be removed.) Final setting should provide enough water flow to evacuate a closet fixture and should be such that a urinal fixture will not overflow when continually flushed. Secure adjusting screw cover.

Metroflush® Parts Replacement and Repair Guide

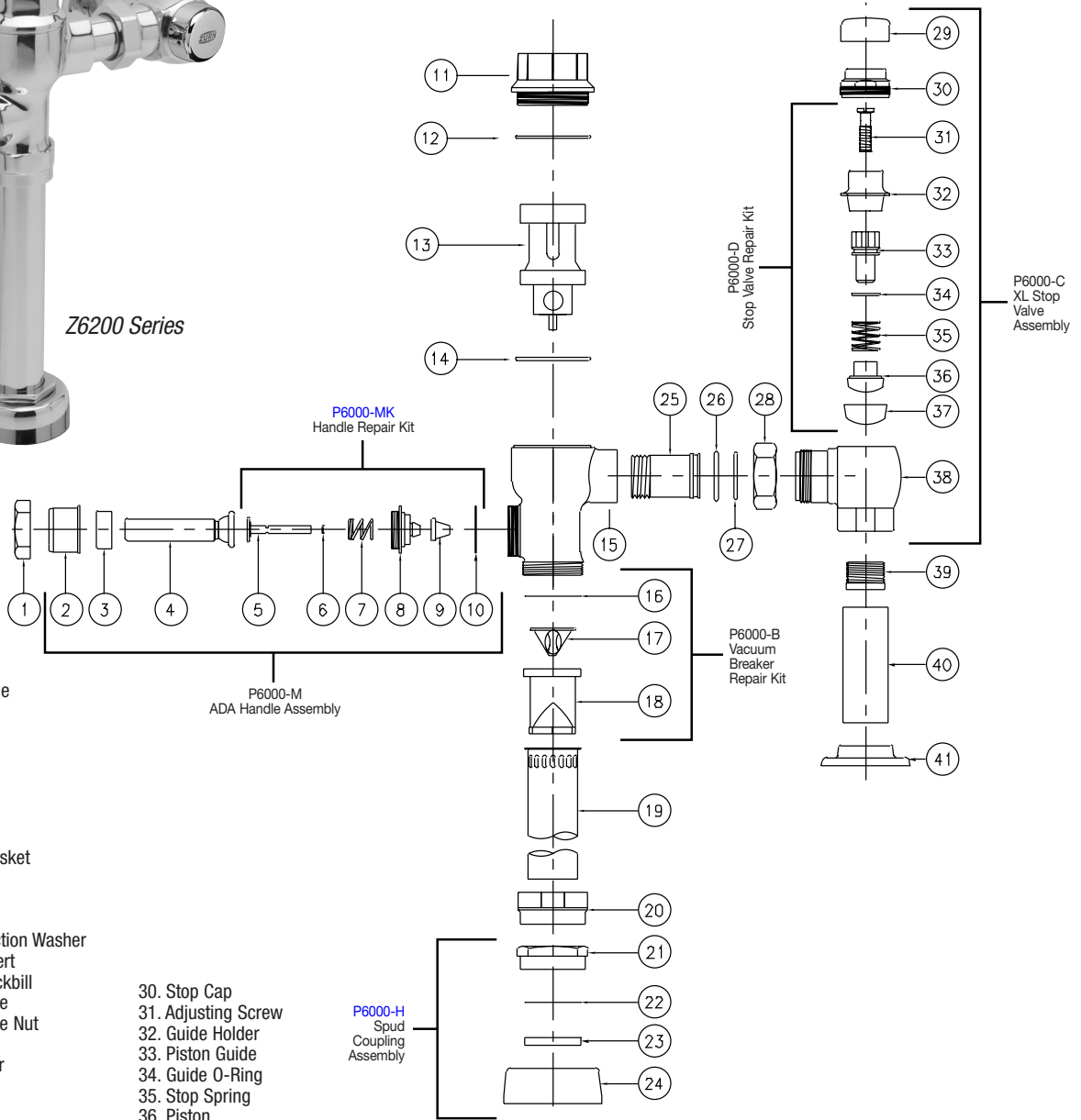

Parts Identification

1. Handle Nut
2. Handle Sleeve
3. Handle Insert
4. Low Force/ADA Compliant Handle
5. Actuator Rod
6. Handle O-Ring
7. Handle Spring
8. Handle Seal Retainer
9. Handle Seal
10. Gasket
11. Valve Body Cover
12. Valve Body Cover Gasket
13. Internal Kit
14. Main Seat
15. Valve Body
16. Vacuum Breaker Friction Washer
17. Vacuum Breaker Insert
18. Vacuum Breaker Duckbill
19. Vacuum Breaker Tube
20. Vacuum Breaker Tube Nut
21. Spud Nut
22. Spud Friction Washer
23. Spud Sleeve
24. Spud Escutcheon
25. Tailpiece
26. Snap Ring
27. Tailpiece O-Ring
28. Locking Nut
29. Vandal-Resistant Control Stop Cover
30. Stop Cap
31. Adjusting Screw
32. Guide Holder
33. Piston Guide
34. Guide O-Ring
35. Stop Spring
36. Piston
37. Piston Seal
38. Stop Body
39. Sweat Solder Adaptor
40. Supply Cover Tube
41. Cast Wall Escutcheon

Covers and Repair Kits	Product No.
Outside Cover - CP - Item 11	P6200-LL
Outside Cover O-Ring - Item 12	P6200-L12
Closet Repair Kit - Item 13	P6200-EC
Urinal Repair Kit - Item 13	P6200-EU
Low Consumption Closet Kit - Item 13	P6200-EC-WS1
Low Consumption Urinal Kit - Item 13	P6200-EU-WS1
Main Seat - Item 14	P6200-E14

Handle Assembly and Repair Kits	Product No.
ADA Handle Assembly (Side), Includes Items 2-10	P6000-M
Handle Repair Kit (Side), Includes Items 5-10	P6000-MK
Handle Seal, Includes Item 9	P6000-M9
Handle Gasket, Includes Item 10	P6000-M10
Control Stop Repair Kit and Parts	Product No.
Control Stop Repair Kit for 1" and 3/4", Includes Items 31-37	P6000-D-SD
Seal Seat for 1" and 3/4", Includes Item 37	P6000-D42
VP Control Stop Repair Kit for 1" and 3/4", Includes Items 31-37	P6000-D-VP
Vandal-Resistant Cover, Includes Item 29	P6000-VC

Adjustable Tailpieces	Product No.
Adjustable Tailpiece for Standard Flush Valve, Includes Items 25-27	P6000-J1
Tailpiece Coupling Assembly, Includes Items 26-28	P6000-K
Tailpiece Locking Ring, Includes Item 26	P6000-C30
Tailpiece O-Ring, Includes Item 26	P6000-C31
Coupling Nut, Includes Item 28	P6000-C32
Flush Connections and Spud Coupling Kits	Product No.
Flush Tube Assembly for Flush Valves, Includes Items 16-20	P6000-A
Specify diameter and length: 1-1/2", 1-1/4", 3/4"	
Vacuum Breaker Repair Kit, Includes Items 16-18	P6000-B
Spud Coupling Assembly, Includes Items 21-24	
Specify size: 1-1/2", 1-1/4", 3/4"	P6000-H

Metroflush
Piston-Operated
Flush Valves



Metroflush® Service Instructions

PROBLEM	CAUSE*	CORRECTIVE ACTION
Valve will not operate.	1.) Stop valve is closed. 2.) Supply valve is closed.	1.) Open stop valve. 2.) Open supply valve.
Insufficient volume of water to adequately siphon fixture.	1.) Stop valve is not open enough. 2.) Urinal piston installed in closet valve. 3.) Insufficient volume or pressure at supply.	1.) Open stop valve for desired volume of water. 2.) Replace urinal piston with proper closet piston. 3.) Consult fixture guide for minimum gallons per minute flow and running pressure for satisfactory fixture performance.
Flush valve shuts off too quick.	1.) Damaged piston. 2.) Enlarged by-pass orifice.	1.) Install new P6200-EC, P6200-EU replacement kit to remedy the problem. 2.) Install new P6200-EC, P6200-EU replacement kit to remedy the problem.
Valve is short flushing.	1.) Enlarged by-pass orifice. 2.) Urinal piston in closet flush valves.	1.) Install new P6200-EC, P6200-EU replacement kit to remedy the problem. 2.) Install closet piston (Item #13).
Valve is flushing too long or not shutting off.	1.) Trip mechanism not seating properly due to foreign material between trip mechanism and seat. 2.) By-pass orifice is plugged or partially plugged. 3.) Line pressure is not adequate to force trip mechanism to seal.	1.) Disassemble parts and rinse thoroughly. 2.) Examine by-pass orifice and clean if necessary being certain not to enlarge orifice opening. 3.) Pressure is inadequate or has dropped below minimum operating range. Steps should be taken to increase the line pressure.
Water splashes out of fixture.	1.) Supply volume is more than is necessary. 2.) Lime accumulation on vortex or spreader holes of fixture.	1.) Adjust downward on control stop. 2.) Remove the lime build up.
Flush is not considered quiet.	1.) Control stop may not be adjusted for quiet operation. 2.) Fixture may be contributing to noise. 3.) Piping system may be source of noise.	1.) Adjust the control stop for quiet operation keeping in mind the fixture evacuation requirements. 2.) Check noise created by fixture by placing a cover over the bowl opening to separate valve noise from bowl noise. If it is determined the fixture is too noisy consult with fixture manufacturer. 3.) High pressure in the system can sometimes be controlled by the stop valve. Other sources of noise may be the absence of air chambers and shock arrestors, loose pipes, improper size pipes, etc. In these cases the building engineer should be consulted.
Handle assembly leaking.	1.) Handle assembly is not tight.	1.) Tighten handle assembly.

Metroflush
Piston-Operated
Flush Valves

Care of Chrome-Plated Surfaces

The suggested cleaning of chrome-plated surfaces is simply to clean them with mild soap and water, then dry. Commercial cleaning compounds are never recommended.

Seasonal Use

Valves used in installations subject to shut down because of cold and freezing conditions should be maintained in the following manner. After the main supply has been shut off and the water drained from the system, remove the stop valve cap and stop valve internals to allow the water to drain from the flush valve itself.



ZURN INDUSTRIES, INC. COMMERCIAL BRASS OPERATION

5900 ELWIN BUCHANAN DRIVE, SANFORD, NC, U.S.A. 27330 PHONE: 1-800-997-3876 FAX: 919/775-3541 WEBSITE: www.zurn.com

In Canada:

ZURN INDUSTRIES LIMITED 3544 NASHUA DRIVE, MISSISSAUGA, ONTARIO L4V 1L2 PHONE: 905/405-8272 FAX: 905/405-1292



PRIOR TO INSTALLATION

Prior to installing the Zurn Automatic Sensor-equipped Flushometer, install the items listed below.

- Single-gang electrical outlet for plug-in power converter.
- Electrical wiring to the power converter outlet (120VAC, 35 watts service required for each power converter used).

IMPORTANT:

- All electrical wiring is to be installed in accordance with National/Local codes and regulations.
- All plumbing is to be installed in accordance with applicable codes and regulations.
- Water supply lines must be sized to supply an adequate volume of water for each fixture.
- Flush all water lines prior to making connections.
- Sensor Units should not be located across from each other or in close proximity to highly reflective surfaces.

The Zurn AquaVantage® valve is designed to operate over the entire pressure range recommended by plumbing fixture manufacturers and will produce a metered flush when activated.

Protect the chrome or special finish of this AquaVantage® valve. **Do not use toothed tools to install or service the valve.** Also, see "Care and Cleaning" section of this manual.

ZEMS6000AV-IS Closet

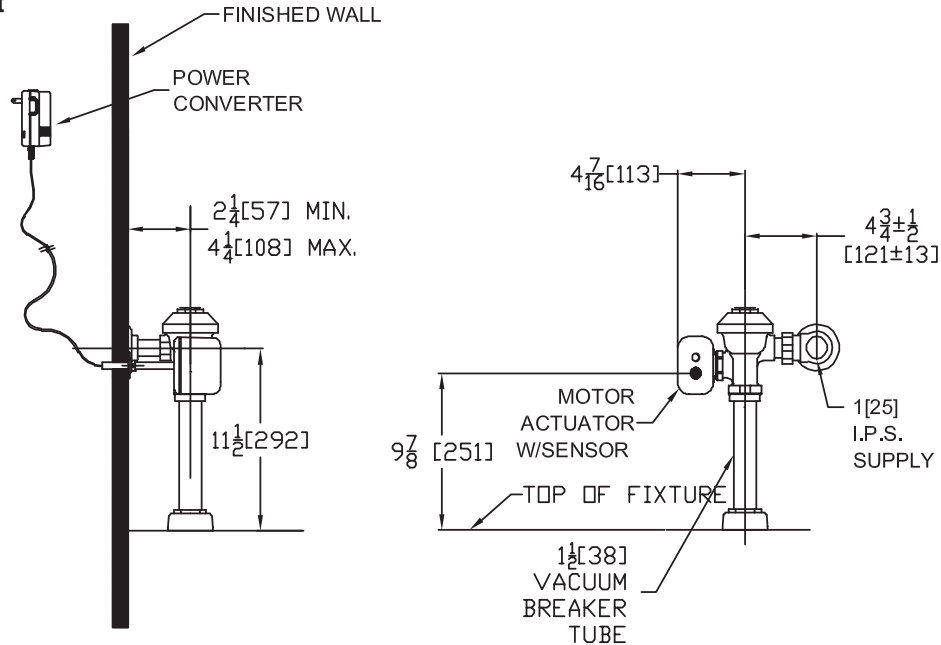

ZEMS6000AV-IS Urinal

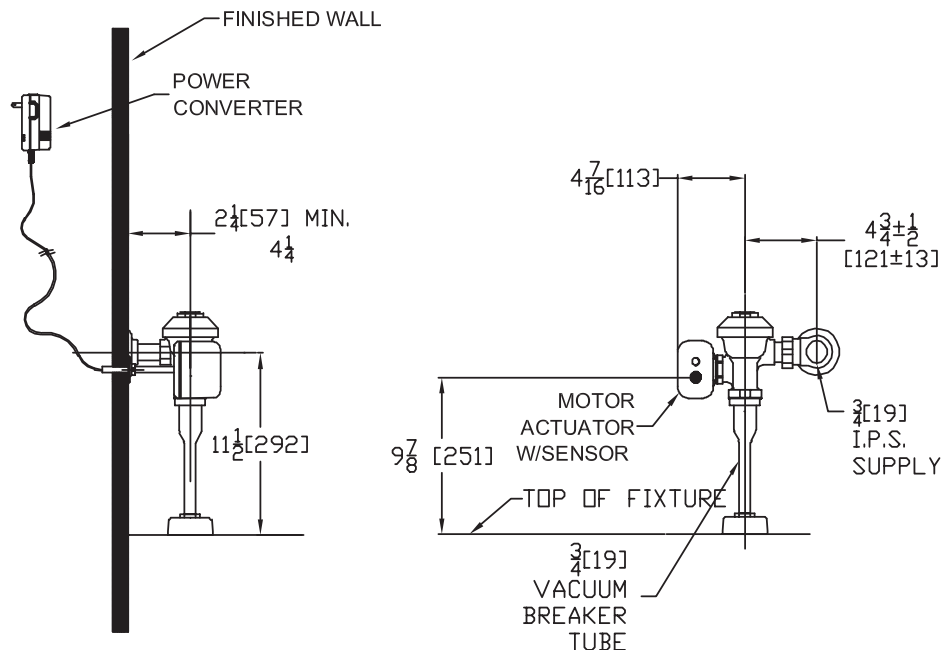

INSTALLATION

STEP 1 – Install Receptacle (Figure 1)

Install receptacle for the Zurn Power Converter in a convenient location near the flush valve. If optional power converter (P6000-HW6) is used, install 4 x 4 electrical box in accordance with local electrical codes. An optional mini junction box (P6000-MJ) is recommended to distribute power to each sensor location.

NOTE: One Power Converter can operate up to eight Automatic Sensor-equipped Flushometers. The Power Converter is supplied with a six-foot cord. If additional wire is needed from the Power Converter to the Flushometer(s), use #18 AWG (by others). **Do not supply power** to the Power Converter until installation of actuator, sensor and Flushometer is completed and checked.

Proper polarity must be observed or damage to one or all components will result.

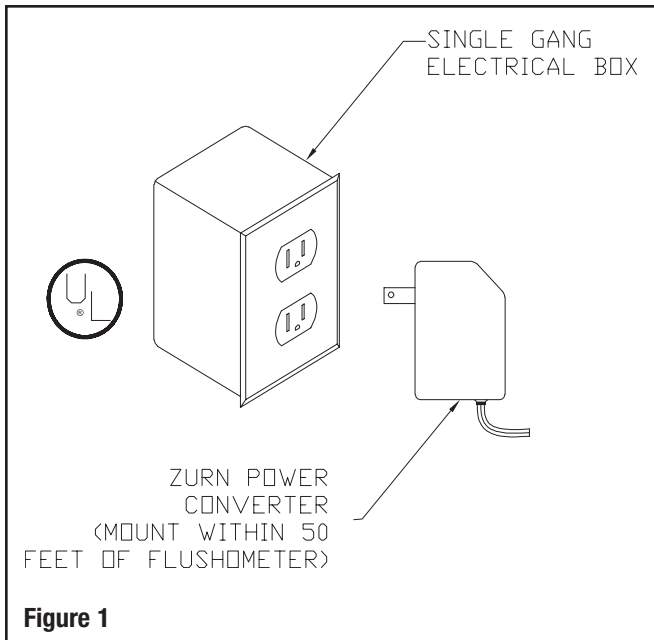

STEP 2 – Electrical Hook-up (Figure 2)

Be certain power is off to prevent damage to electrical components. Connect wires per schematic. Black wire is negative and black wire w/white stripe is positive. **Do not reverse polarity.** Multiple actuator wiring shown.

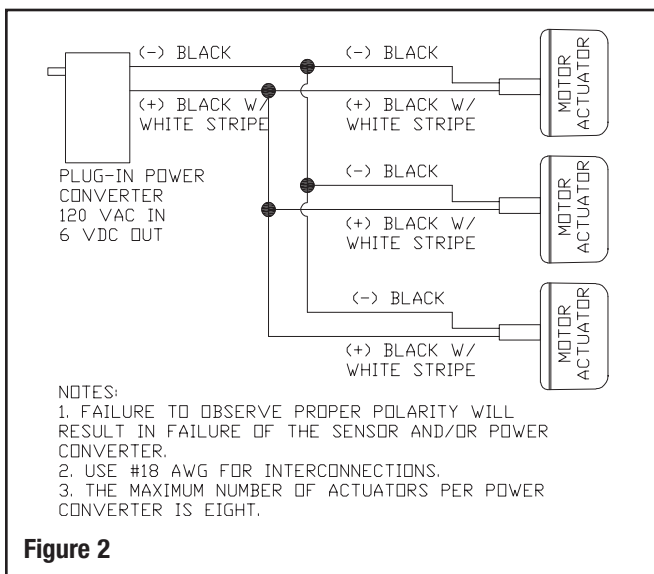

STEP 3 – Optional Mini Junction Box (Figure 3)

When using optional mini junction box, be certain power is off while making wire connections to prevent damage to electrical components. The maximum number of actuators per converter is 8.

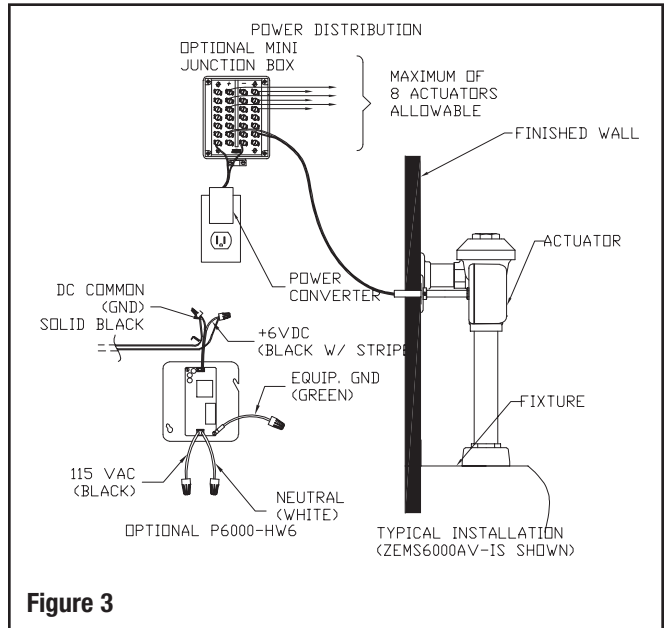

STEP 4 – Verify Plumbing Location (Figure 4)

Confirm the ZEMS-IS sensor hole is located properly per template. The 6VDC power chord (Part #PEMS6000-CW) should already be in place.

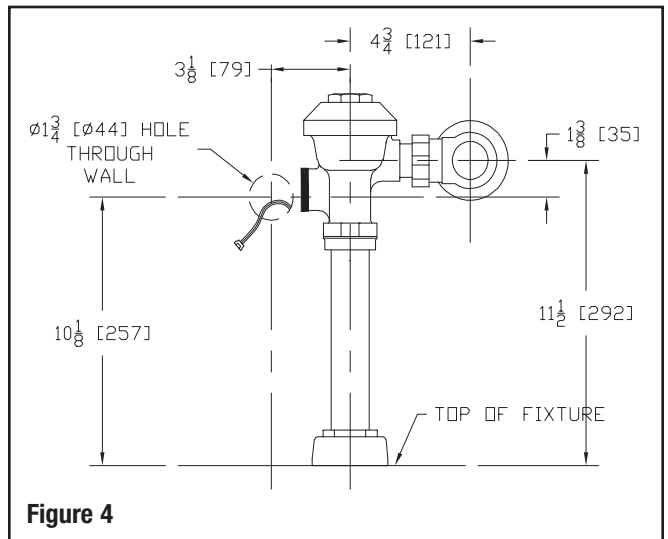



STEP 5 – Control Stop Installation (Figure 5)

Install the Zurn control stop valve and wall escutcheon to the water supply line with the outlet positioned as required.

NOTE: For sweat solder applications, see recommended instructions included in the Zurn sweat solder kit.

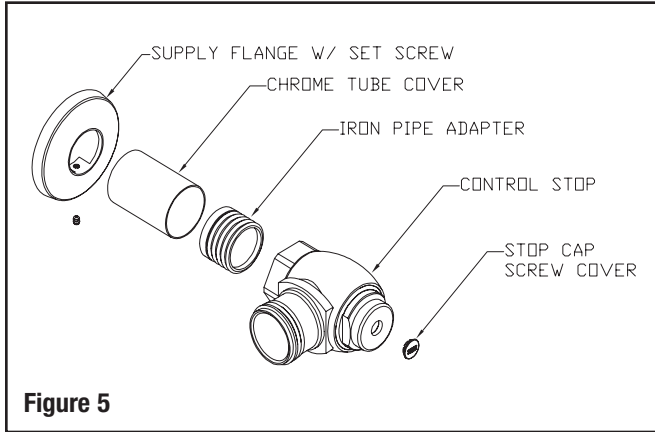

Figure 5

STEP 6 – Vacuum Breaker Flush Connection (Figure 6)

Slide the tube nut, slip washer, rubber gasket and spud escutcheon over the vacuum breaker tube and insert tube into fixture spud. Hand tighten spud coupling into fixture spud.

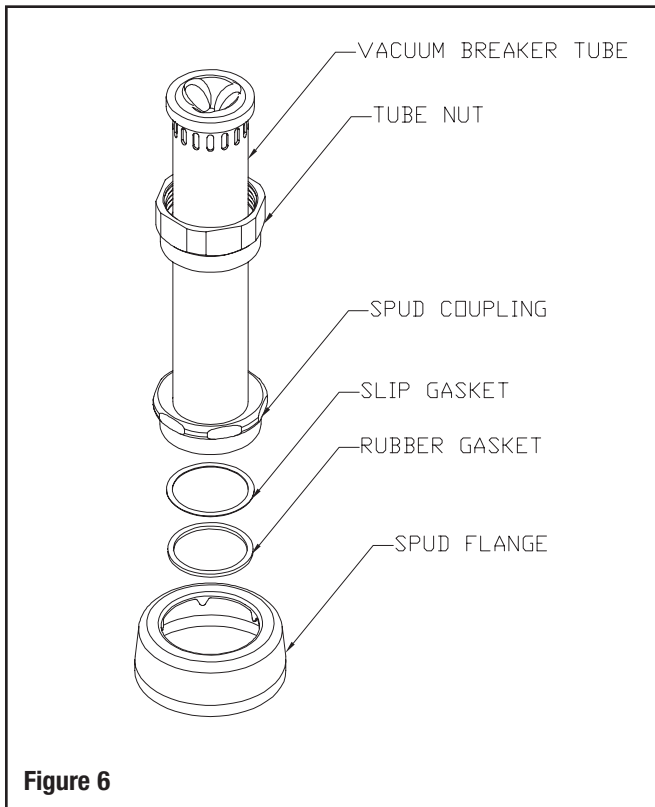

Figure 6

STEP 7 – Valve Installation (Figure 7)

Install valve to control stop with the bottom of the valve tilted slightly up toward you and leave the valve nut loose. Make sure not to damage O-ring on valve. Install vacuum breaker into vacuum tube and place slip gasket between vacuum breaker and valve. Then rotate valve down over vacuum breaker tube and tighten tube nut to valve. After tube nut is tight, tighten valve nut to control stop.

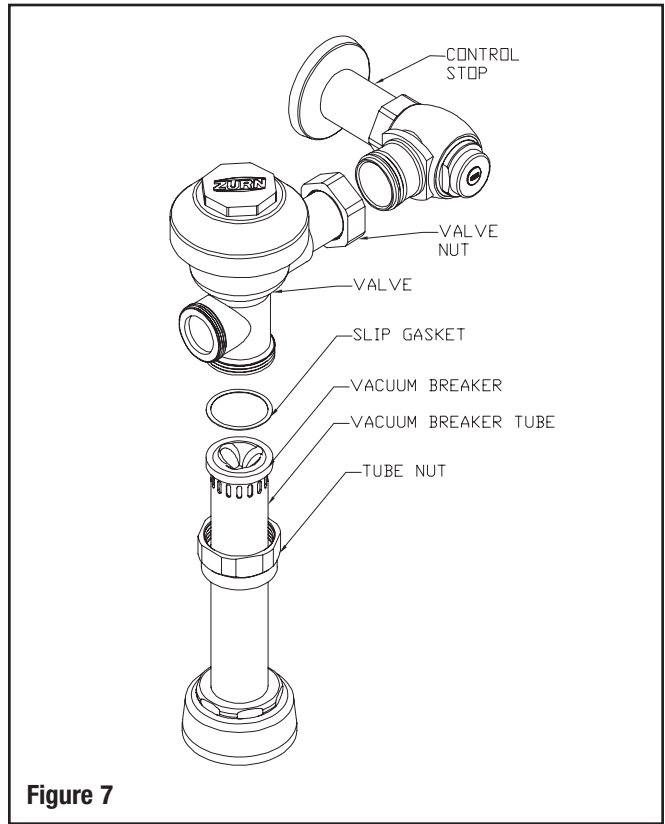

Figure 7

STEP 8 – Actuator Installation (Figure 8)

Run wires and rod through hole in wall. Install handle gasket into actuator nut and tighten actuator to valve. Push wall flange against wall and tighten setscrew.

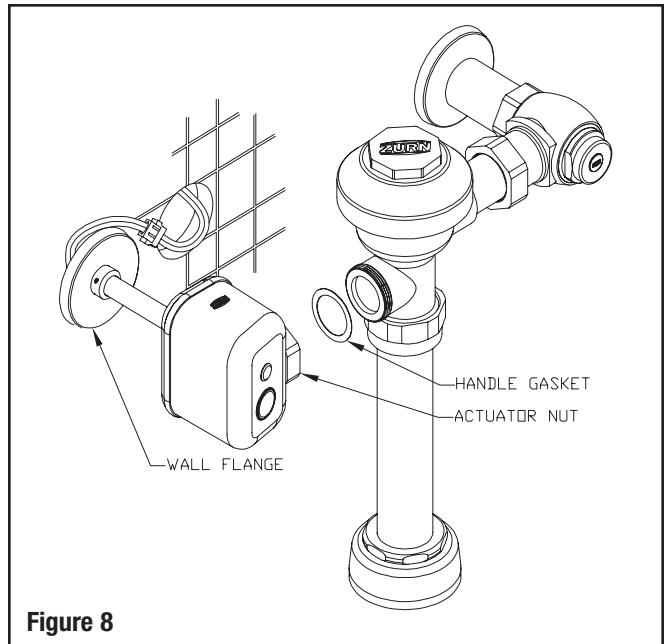

Figure 8

STEP 9 – Flush Out Supply Line (Figure 9)

Close control stop. Remove valve body cover and lift out trip mechanism. Re-install internal cap and valve body cover. Turn on water supply to flush line of any debris or sediment.

After completion, shut off control stop, remove cover and re-install the trip mechanism. Install the internal cap and valve body cover wrench tight.

STEP 10 – SENSOR CALIBRATION

Factory Setting

The Zurn ZEMS-IS sensor module is factory set to accommodate closet and urinal installations. Wiring the unit per the enclosed wiring diagram (Figure 2) with 6VDC power recalls the factory setting. The ZEMS-IS unit is ready for operation. **Note:** During the first 30 minutes of power up, a red flashing light (Figure 10) will illuminate to indicate an optional customized sensor range setting is available if desired.

Customized Sensor Range Setting

To customize the sensor range for a particular installation, simply set a dummy target (stall door or light colored piece of cardboard) at the desired sensor range distance as illustrated in Figure 11. Disrupt the 6VDC power source for two minutes then restore power. PRESS and HOLD the manual override button for ten seconds anytime during the first 30 minutes of power up (red light blinks during the first 30 minutes of power up to help identify this time period). Pressing the override button activates the motor actuator. Continue to HOLD the override button until the flashing red light stops. This indicates that a ten second HOLD was achieved. Step back away from the valve so as not to be in the view of the sensor. The ZEMS-IS unit will self-calibrate to the given target over the next 45 seconds. A series of lights will follow (3 flashes, 16 flashes, 1 flash, a solid 16-second red light followed by 2 more flashes). This pattern of flashing lights indicates the sensor has self-adjusted to the given environment and is now calibrated to the new target.

STEP 11 – Activating the Motor Actuator with the Sensor

To activate the motor actuator with the sensor, simply place a target in front of the sensor. A single red light will flash indicating the sensor has recognized the target. If the target stays in view for eight seconds, two flashing red lights will occur. This indicates that the target has been in view for the required time and upon leaving the view, a signal will be sent to the motor actuator to flush the flush valve. **Note:** If the target does not stay in view for the required eight seconds, a flush will not occur.

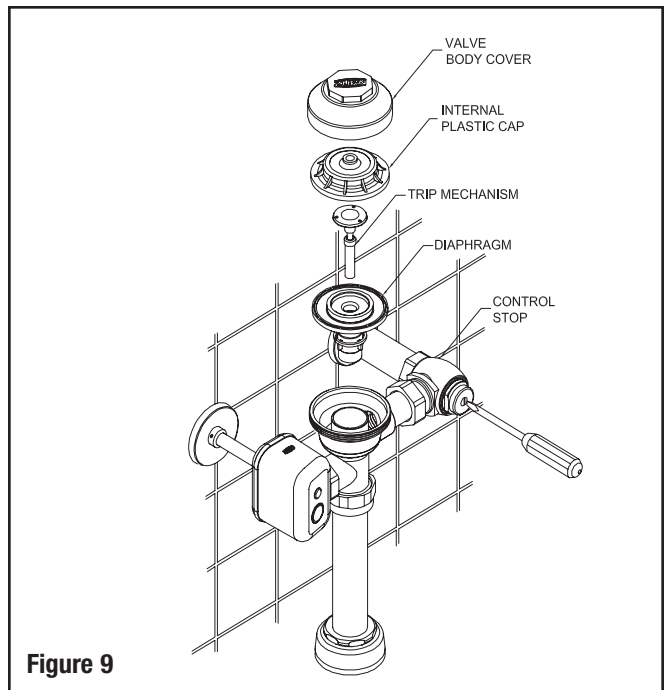

Figure 9

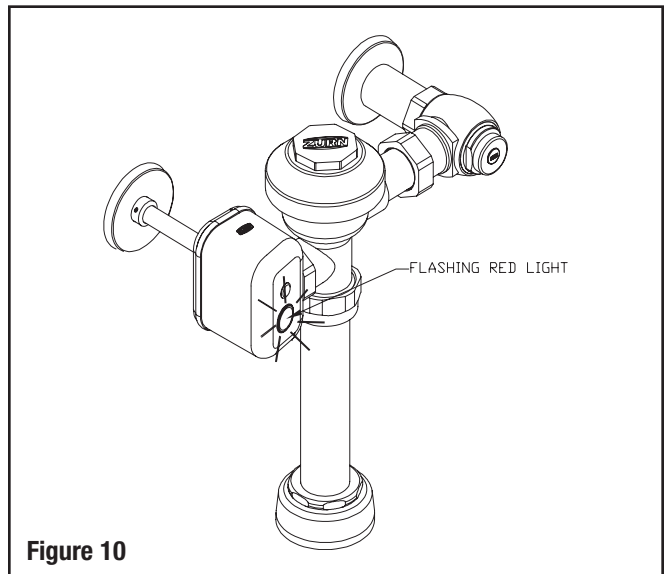

Figure 10

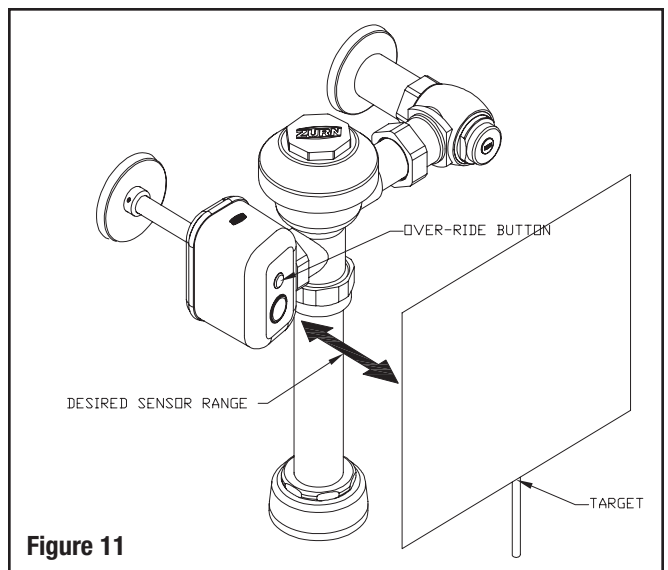

Figure 11





AquaVantage® ZEMS-IS Parts Breakdown

Part Identification

1. Cast Wall Escutcheon
2. Setscrew for Cast Wall Escutcheon
3. Supply Cover Tube
4. Sweat Solder Adapter
5. Stop Body
6. Piston Seal
7. Piston
8. Stop Spring
9. Guide O-Ring
10. Piston Guide
11. Guide Holder
12. Adjusting Screw
13. Stop Cap
14. Snap Cap Screw Cover
15. Vandal-Resistant Control Stop Cover
16. Setscrew for Control Stop Cover
17. Locking Nut
18. Tailpiece O-Ring
19. Snap Ring
20. Tailpiece
21. Valve Body Cover
22. Plastic Cover
23. Trip Mechanism
24. Diaphragm Repair Kit
25. Valve Body
26. Gasket
27. ZEMS-IS Actuator Assembly
28. Vacuum Breaker Friction Washer
29. Vacuum Breaker Insert
30. Vacuum Breaker Duckbill
31. Vacuum Breaker Tube
32. Vacuum Breaker Tube Nut
33. 1-1/2" Spud Nut
34. 1-1/2" Spud Friction Washer
35. 1-1/2" Spud Sleeve
36. Spud Escutcheon
37. 3/4" Spud Nut
38. 3/4" Spud Friction Washer
39. 3/4" Spud Sleeve
40. 3/4" Spud Escutcheon
41. 10' Power Cord
42. 120VAC/6VDC Plug-in Power Converter

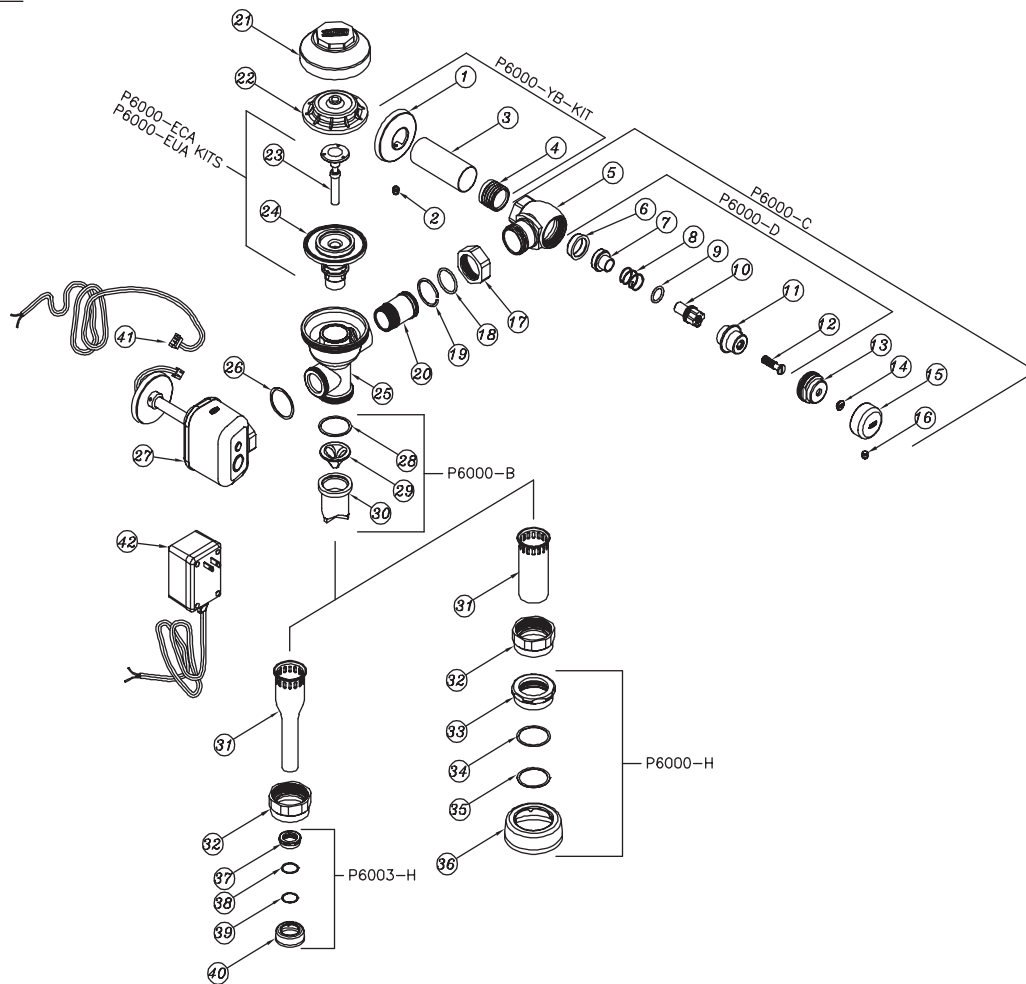

Covers and Repair Kits	Product No.
Outside Cover – Item 21	P6000-LL
Inside Cover – Item 22	P6000-L
Low Consumption Closet Kit - 1.6 gal. flush	P6000-ECA-WS1
Water Saving Closet Kit - 3.5 gal. flush	P6000-ECA-WS
Full Flow Closet Kit - 4.5 gal. flush	P6000-ECA-FF
Low Consumption Urinal Kit - 1.0 gal. flush	P6000-EUA-WS1
Water Saving Urinal Kit - 1.5 gal flush	P6000-EUA-WS
Full Flush Urinal Kit - 3.0 gal. flush	P6000-EUA-FF

Repair Parts – Inside Parts	Product No.
Urinal Trip Mechanism – Item 23	P6000-EUA13
Closet Trip Mechanism – Item 23	P6000-ECA13

AquaVantage Rebuild Kits	Product No.
Closet and Urinal Rebuild Kits Include Items 18, 23, 24, 26, 28-30	P6000-ECA-WS-RK P6000-ECA-WS1-RK P6000-EUA-WS-RK P6000-EUA-WS1-RK

Actuator Assembly and Repair Kits	Product No.
Motor Actuator/Sensor – Item 27	PEMS6000-HYM-IS
10-Foot Length of Power Cord – Item 41	PEMS6000-CW
120VAC/6VDC Plug-in Power Converter – Item 42	P6000-PC6
Handle Gasket Includes – Item 26	P6000-M10

Control Stop Repair Kit and Parts	Product No.
Control Stop Repair Kit for 1" and 3/4", Includes Items 6-12	P6000-D-SD
Seal Seat for 1" and 3/4", Includes Item 6	P6000-D42
Sweat Solder Adapter	P6000-YBA

Adjustable Tailpieces	Product No.
Adjustable Tailpiece for Standard Flush Valve, Includes Items 18-20	P6000-J1
Tailpiece Locking Ring, Include Item 19	P6000-C30
Tailpiece O-Ring, Includes Item 18	P6000-C31
Coupling Nut, Includes Item 17	P6000-C32

Flush Connections and Spud Coupling Kits	Product No.
1-1/2" Flush Connection and Spud Coupling	P6000-H
3/4" Flush Connection and Spud Coupling	P6003-H
Vacuum Breaker Repair Kit, Includes Items 28-30	P6000-B
Spud Coupling Assembly (Specify Size)	P6000-HN

AquaVantage® ZEMS-IS Trouble-Shooting Guide



Problem	Cause*	Corrective Action*
Valve will not operate.	<ol style="list-style-type: none"> 1.) Stop valve is closed. 2.) Supply valve is closed. 	<ol style="list-style-type: none"> 1.) Open stop valve. 2.) Open supply valve.
Insufficient volume of water to adequately flush fixture.	<ol style="list-style-type: none"> 1.) Stop valve is not open enough. 2.) Urinal trip mechanism installed in closet kit. Urinal kit installed in closet valve, or 1.0 gal. urinal kit installed in place of 1.5 gal. urinal kit. 3.) Insufficient volume or pressure at supply. 	<ol style="list-style-type: none"> 1.) Open stop valve for desired volume of water. 2.) Install appropriate parts or kit. 3.) If gauges are not available to measure supply pressure or volume of water at the valve, completely remove the working parts and open the stop valve to allow water to pass through the empty valve. If the water supply proves unsatisfactory, steps should be taken to increase the pressure and/or supply.
Flush valve does not activate after user leaves.	<ol style="list-style-type: none"> 1.) Sensor does not recognize a user. 2.) Power supply may be disrupted. 	<ol style="list-style-type: none"> 1.) Shut off the 6VDC power supply for 2 minutes and recalibrate sensor per step 10. 2.) Check available voltage where escutcheon is attached to wall. 6-9VDC is required.
Flush valve shuts off too quickly.	<ol style="list-style-type: none"> 1.) Damaged or punctured diaphragm. 2.) Enlarged by-pass orifice. 3.) Cylinder guide assembly and diaphragm assembly are not tight. 4.) Enlarged by-pass orifice. 5.) Urinal trip mechanism (black) in closet flush valves. 	<ol style="list-style-type: none"> 1.) Install new replacement kit to remedy the problem. 2.) Install new replacement kit to remedy the problem. 3.) Screw the two assemblies hand tight. 4.) Install new Z6000-ECA, Z6000-EUA replacement kit to remedy the problem. 5.) Install closet trip mechanism (white).
Valve is flushing too long or not shutting off.	<ol style="list-style-type: none"> 1.) Trip mechanism not seating properly due to foreign material between trip mechanism and retainer disc. 2.) By-pass orifice is plugged or partially plugged. 3.) Line pressure is not adequate to force trip mechanism to seal. 4.) Cracked cover. 	<ol style="list-style-type: none"> 1.) Disassemble parts and rinse thoroughly. 2.) Examine by-pass orifice and clean if necessary being certain not to enlarge orifice opening. 3.) Pressure is inadequate or has dropped below minimum operating range. Steps should be taken to increase the line pressure. 4.) Replace cover with new one.
Water splashes out of fixture.	<ol style="list-style-type: none"> 1.) Supply volume is more than is necessary. 2.) Lime accumulation on vortex or spreader holes of fixture. 	<ol style="list-style-type: none"> 1.) Adjust downward on control stop. 2.) Remove the lime buildup within the fixture.
Flush is not considered quiet.	<ol style="list-style-type: none"> 1.) Control stop may not be adjusted for quiet operation. 2.) Fixture may be contributing to noise. 3.) Piping system may be source of noise. 	<ol style="list-style-type: none"> 1.) Adjust the control stop for quiet operation keeping in mind the fixture evacuation requirements. 2.) Check noise created by fixture by placing a cover over the bowl opening to separate valve noise from bowl noise. If it is determined the fixture is too noisy, consult with fixture manufacturer. 3.) High pressure in the system can sometimes be controlled by the stop valve. Other sources of noise may be the absence of air chambers and shock arrestors, loose pipes, improper size pipes, etc. In these cases the building engineer should be consulted.
Chattering noise in flush valve.	<ol style="list-style-type: none"> 1.) Diaphragm has been installed upside down. 2.) The inside cover has been distorted by freezing 	<ol style="list-style-type: none"> 1.) Reposition diaphragm as instructed by the markings on the diaphragm (this side up) 2.) Replace both inside plastic cover and outside chrome-plated brass cover.
Sensor assembly leaking.	<ol style="list-style-type: none"> 1.) Sensor assembly is not tight. 	<ol style="list-style-type: none"> 1.) Tighten sensor assembly.

Care of Chrome-Plated Surfaces

The suggested cleaning of chrome-plated surfaces is simply to clean them with soap and water then dry. Commercial cleaning compounds are never recommended.

Seasonal Use

Valves used in installations subject to shutdown because of cold and freezing conditions should be maintained in the following manner. After the main supply has been shut off and the water drained from the system, remove the stop valve cap and stop valve internals to allow the water to drain from the flush valve itself.



AquaSense Hardwired
Flush Valves



ZURN PLUMBING PRODUCTS GROUP, COMMERCIAL BRASS OPERATION, 5900 ELWIN BUCHANAN DRIVE, SANFORD, NC 27330
PHONE: 800/997-3876 FAX: 919/775-354 WEBSITE: www.zurn.com

ZURN INDUSTRIES LIMITED, 3544 NASHUA DRIVE, MISSISSAUGA, ONTARIO L4V 1L2 PHONE: 905/405-8272 FAX: 905/405-1292