



Serio Series™ Faucet

Sensor-Operated Lavatory Faucets
for Battery or Plug-In Installations.

Installation, Operation, Maintenance,
and Parts Manual



Z6950-XL-S



Z6950-XL-IM-S*



Z6955-XL-S

Sensor-Operated Battery-Powered Lavatory Faucets

NOTICE: READ ENTIRE MANUAL PRIOR TO INSTALLING PRODUCT.

⚠ WARNING: Cancer and Reproductive Harm - www.P65Warnings.ca.gov

⚠ ADVERTENCIA: Cáncer y daño reproductivo - www.P65Warnings.ca.gov

⚠ AVERTISSEMENT: Cancer et effets néfastes sur la reproduction - www.P65Warnings.ca.gov

LIMITED WARRANTY

All goods sold hereunder are warranted to be free from defects in material and factory workmanship for a period of three years from the date of purchase. Decorative finishes warranted for one year. We will replace at no costs goods that prove defective provided we are notified in writing of such defect and the goods are returned to us prepaid at Sanford, NC, with evidence that they have been properly maintained and used in accordance with instructions. We shall not be responsible for any labor charges or any loss, injury or damages whatsoever, including incidental or consequential damages. The sole and exclusive remedy shall be limited to the replacement of the defective goods. Before installation and use, the purchaser shall determine the suitability of the product for his intended use and the purchaser assume all risk and liability whatever in connection therewith. Where permitted by law, the implied warranty of merchantability is expressly excluded. If the products sold hereunder are "consumer products," the implied warranty of merchantability is limited to a period of three years and shall be limited solely to the replacement of the defective goods. All weights stated in our catalogs and listed are approximate and are not guaranteed.

NOTE: The information in this manual is subject to change at any time without notice. Installations may be performed at different times of construction by different individuals. For this reason, these instructions should be left on-site with the facility or maintenance manager.

*HYDRO-X Power not included with integral mixer (IM) faucets.

Rev. B | Date: 12/05/22 | C.N. No. 144945 | Prod./Dwg. No. FV794

Patent zurn.com/patents

US 1.855.0NE.ZURN CANADA 1.877.892.5216

ZURN.COM

by **ZURN ELKAY** Water Solutions

This Page Intentionally Left Blank

Serio Series™ Faucets Package Contents

Z6950-XL-S

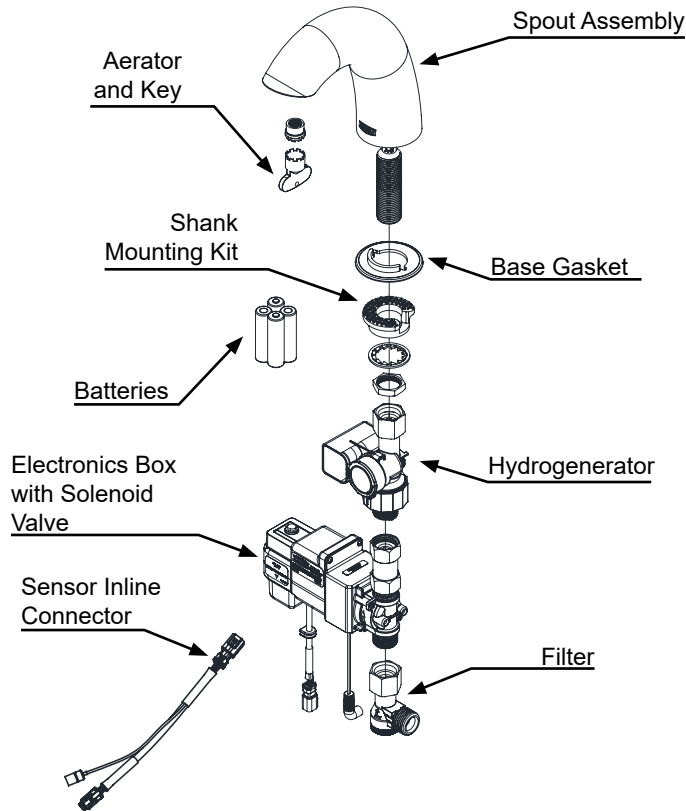

Z6955-XL-S

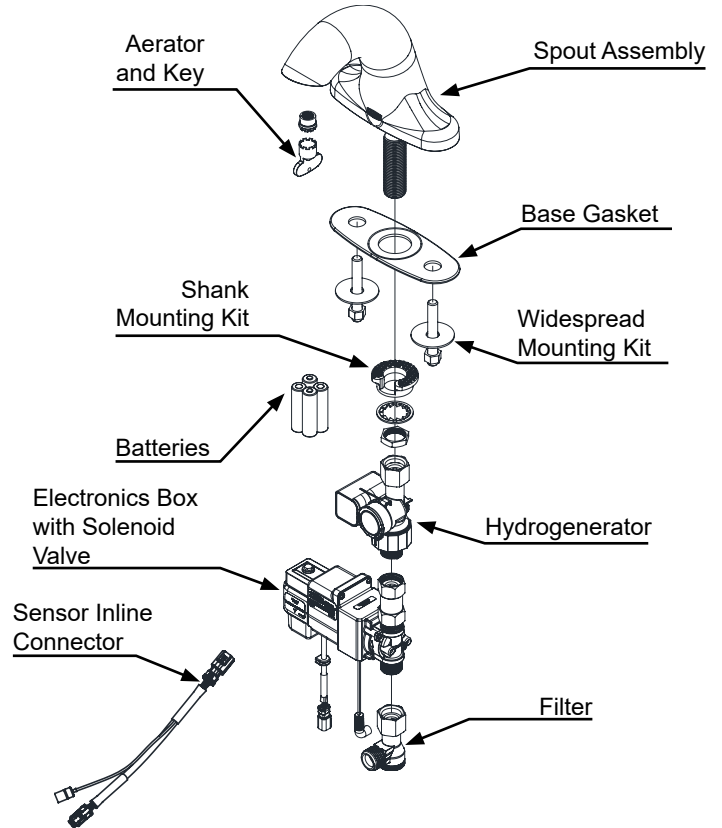

Z6950-XL-IM-S

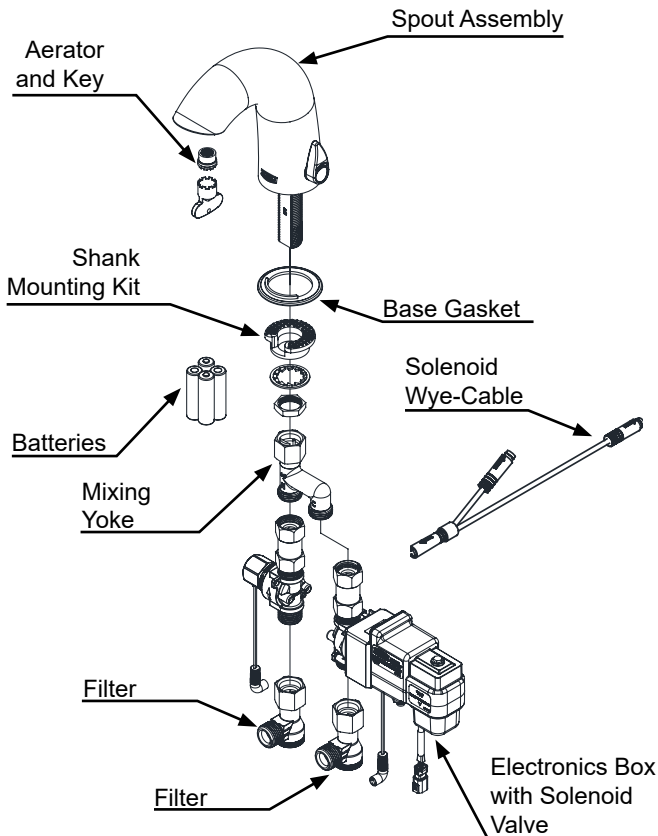

Required Tools:

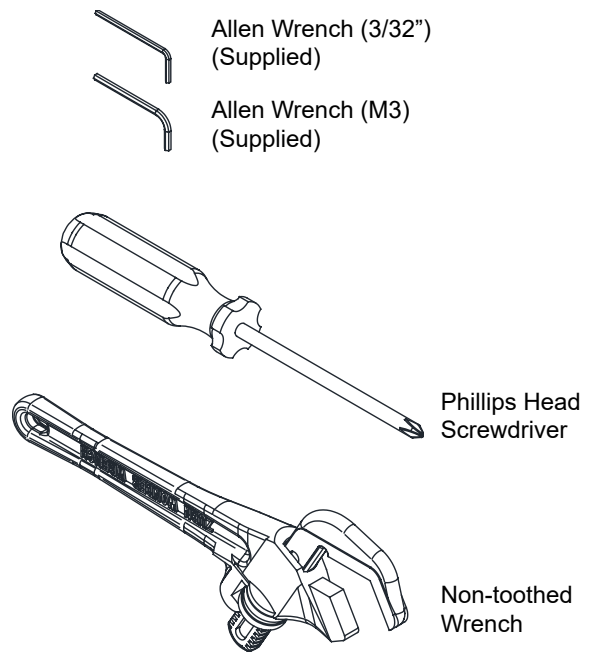

Overview:

Zurn® Serio Series™ Faucets features multiple spout designs in a standard polished chrome finish with one piece heavy duty cast brass spouts and advanced electronic components and feature sets. Sophisticated automatic user detection and self-calibration ensures the user does not need to touch the faucet and helps deliver optimum water savings.

Specifications:

Voltage:	6 VDC Series [4 "AA" (Alkaline or Lithium) and/or external power option]
Sensor Range:	Self-calibrated, dependent upon sink depth and finish.
Operating Water Pressure:	10-125 psi
Operational Water Temperature:	33°F to 140°F (1°C to 60°C)
Aerator:	0.5 GPM Vandal-Resistant (Standard)

Important Safety Information:

- Installer is responsible for ensuring the product is installed and conforms to all plumbing codes and ordinances.
- Do not convert or modify this Zurn product yourself. All warranties will be voided.
- Water supply lines must be sized according to building designer in order to provide adequate water supply for each fixture.
- Flush all water lines prior to making connections.

 *Warning: Do not connect an external power supply to the hydrogenerator's barrel jack connector. Doing so could reduce product performance or pose a fire hazard*

Prior to Installation:

Before installing your Zurn® Serio Series™ Faucet: the items listed below should already be installed on site.

- Lavatory/sink
- Drain Line
- Hot and cold water supply line or pre-tempered water supply line.
- Installer/Service should not use pipe dope or teflon/thread sealant anywhere on this product, most notably threads and connection points.
- Care shall be taken when installing this product to prevent marring of any exposed or decorative surfaces.

 *Be sure the sink/lavatory/basin is clear from any objects upon making the sensor to electronics connection initiating the self-calibration feature. The sink must be clear of any and all objects in order to calibrate appropriately (calibration time approx 30-60sec).*

NOTE: The information in this manual is subject to change at any time without notice. Installations may be performed at different times of construction by different individuals. For this reason, these instructions should be left on-site with the facility or maintenance manager.

NOTE: Before installation, turn off water supplies to existing faucet and remove faucet if replacing an existing device. Clean the faucet basin and clear away debris. Flush all supply lines before connecting the faucet. Failure to do so may result in debris clogging the inlets and/or internal control and mixing valve

Spout Installation - Step 1

1.1. Carefully screw aerator into spout using included tool.

⚠ Take care to not pinch blue o-ring, it may help to wet the o-ring.

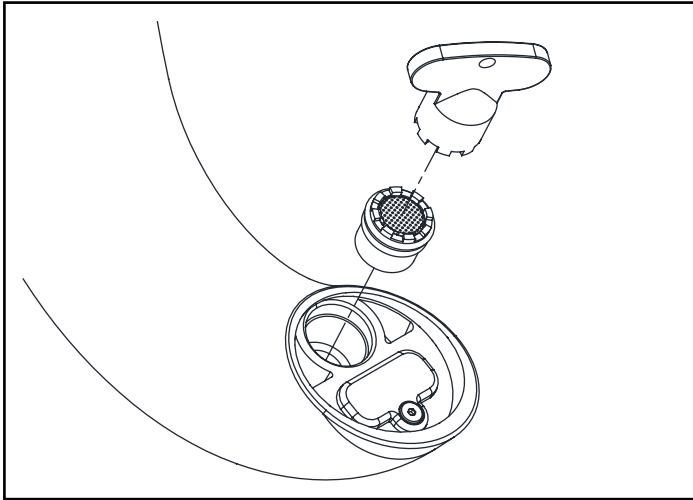

1.3. Ensure that slot in plastic washer is facing forward.

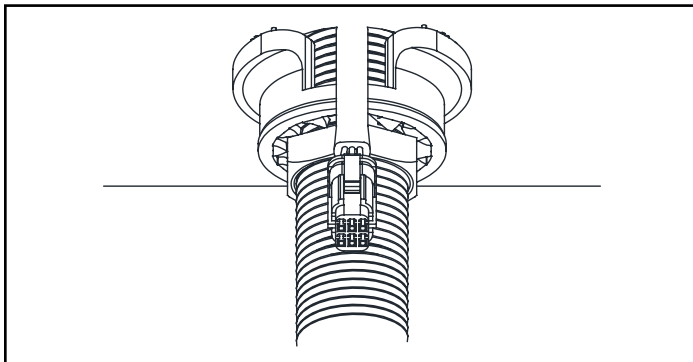

⚠ Sensor cable should not pass through plastic mounting washer.

1.2. Install spout to sink using spout base gasket, plastic mounting washer, star washer and mounting nut (and cover plate for versions that are included).

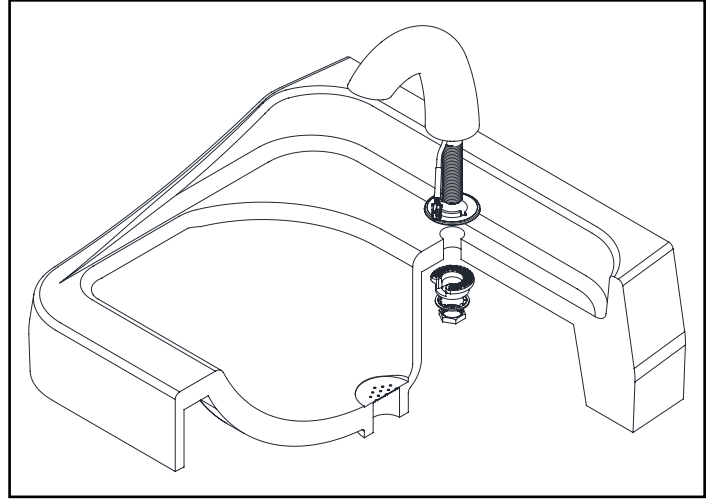

1.2a. Z6955 version – secure two additional bolts using the provided washers and nuts.

Electronics Module Installation - Step 2

2.1. Assemble the electronics module

2.1a. For non-IM assembly, connect hydrogenerator(A) downstream of electronics module(B) and filter(C) to bottom of electronics module.

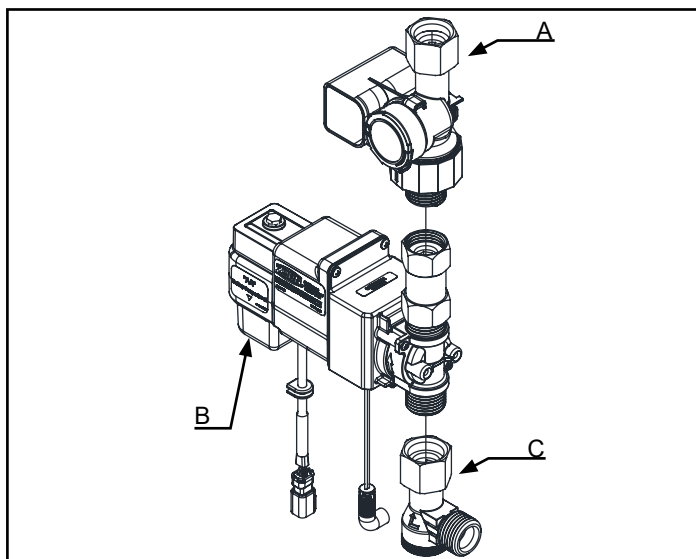

2.1b. For IM assembly, connect mixing yoke(A) and two filters(B) to the electronics modules(C)(D). Electronics module(C) should be on hot line and electronics module (D) should be on cold line.

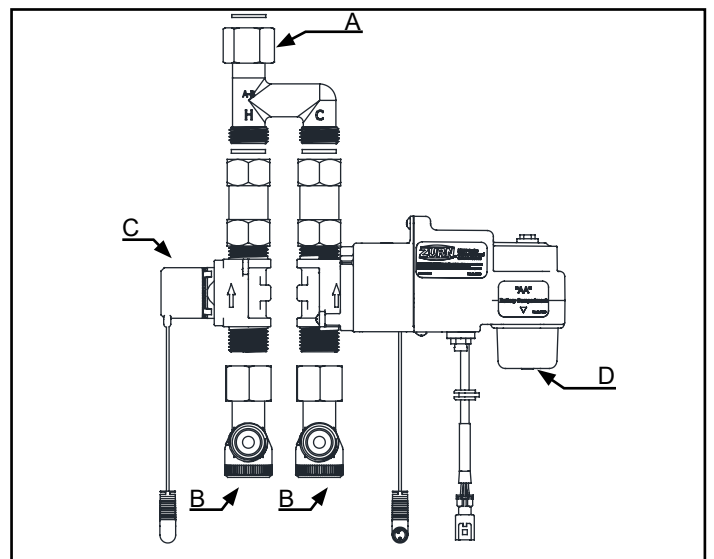

2.2. IM assembly only: Connect wye-cable to electronics modules.

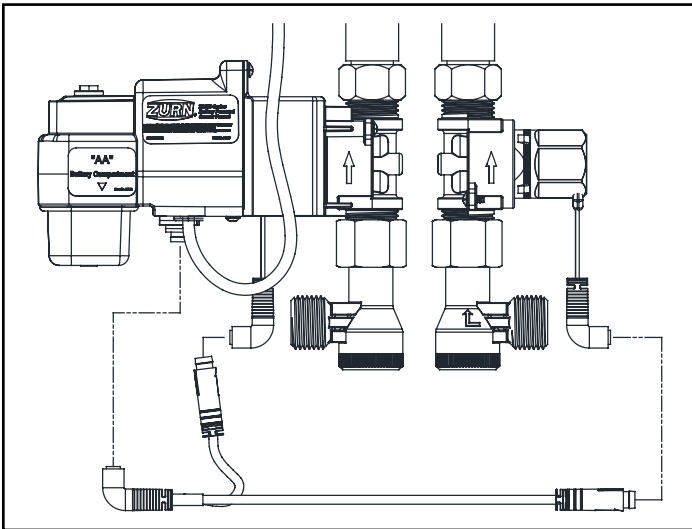

2.3. For battery-powered, non-IM version, connect sensor inline connector to electronics module and hydrogenerator.

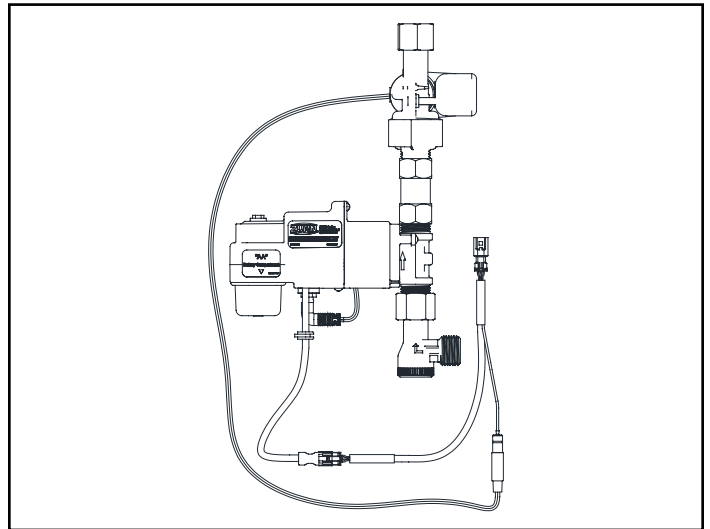

2.4. Open battery module using supplied Allen wrench and install supplied batteries in the electronics module.

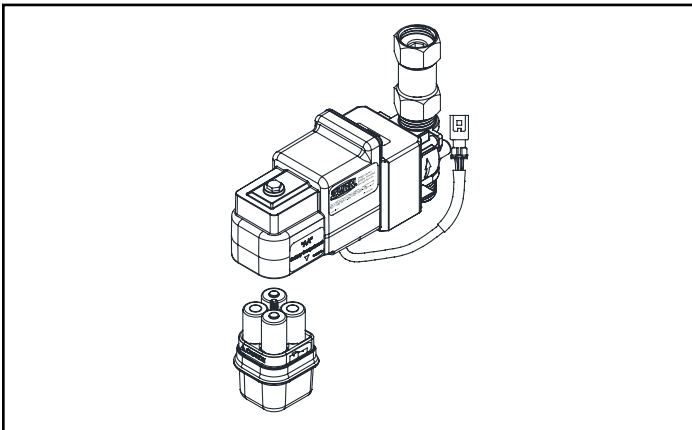

2.4a. Optional ACA version: Connect supplied inline connector and AC adapter.

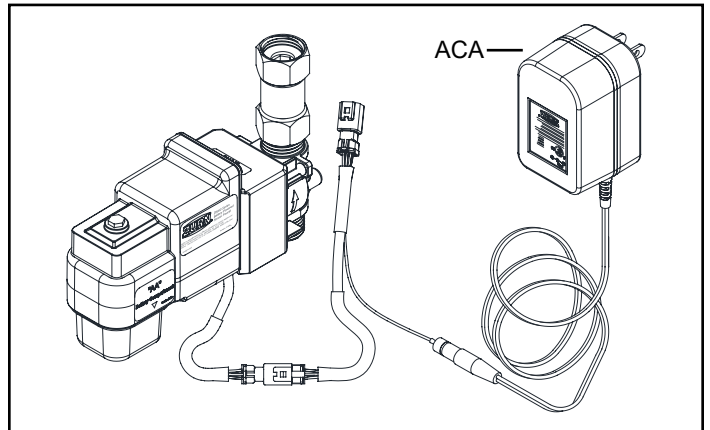

2.4b. Optional HW6 (Hardwired 6V) version: Connect supplied inline connector and hardwire adapter. When securing the wire terminals on HW6 unit, the BLACK WITH DASHED MARKINGS should be connected to the Positive (+) terminal, and the SOLID BLACK wire should be connected to the Negative (-) terminal.

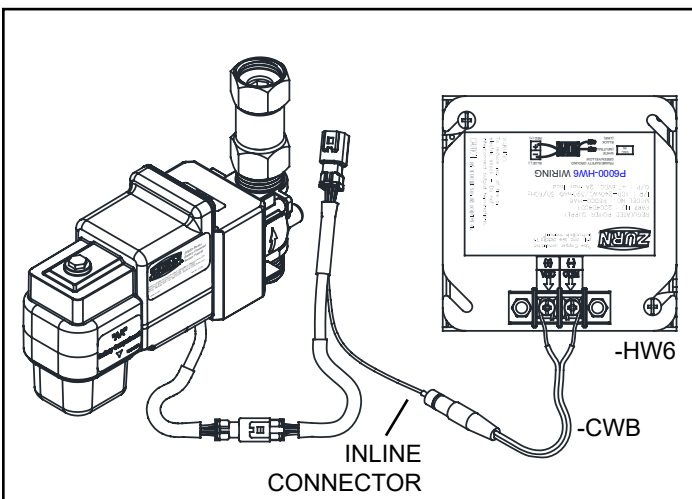

MJ unit (sold separately)

Note: Do not connect more than 8 solenoids to a single transformer

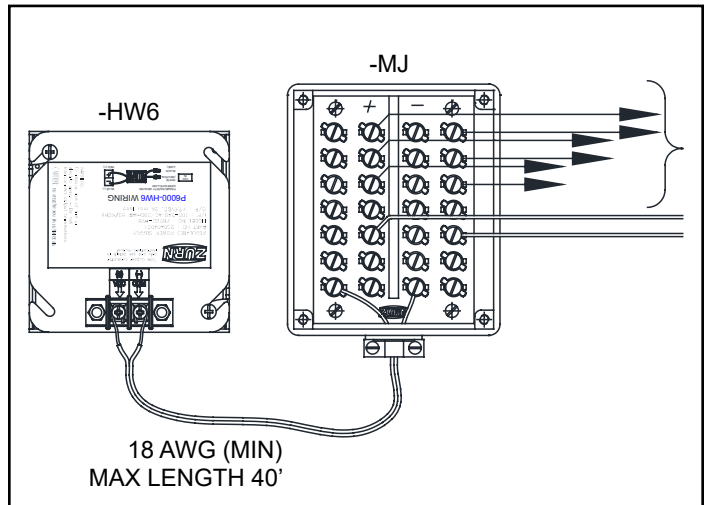

2.5. Tighten electronics module assembly with hydrogenerator to shank and connect water line(s).

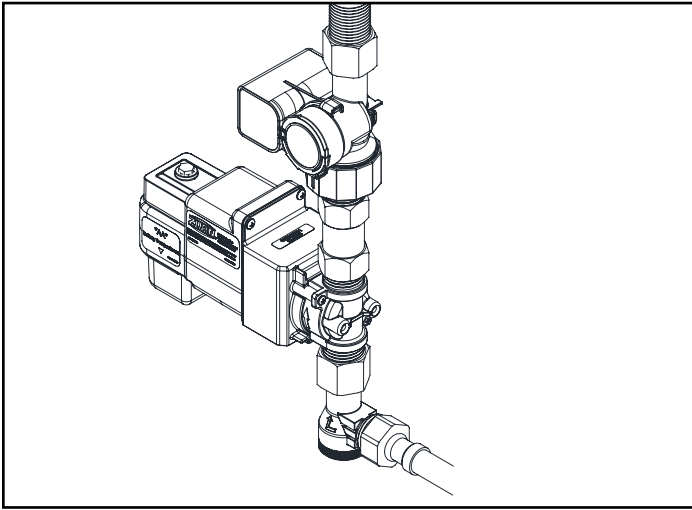

2.5.a. For IM assembly, tighten mixing yoke with electronics module and hydrogenerator assembly to shank and connect water line(s).

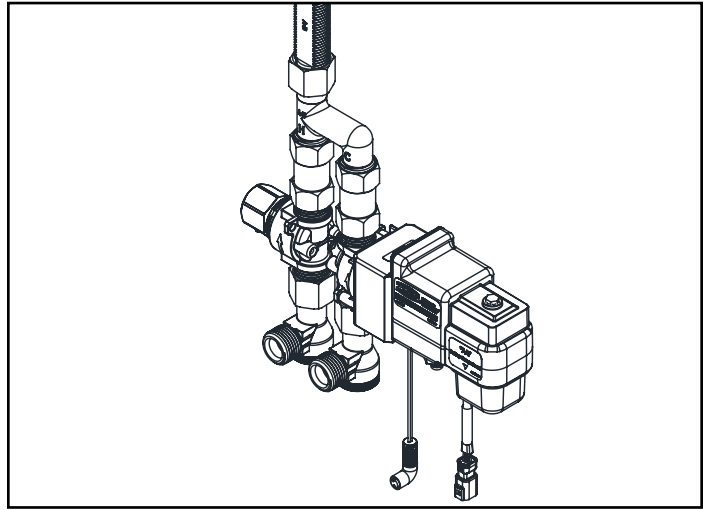

2.6. Turn on water supply(ies).

2.7. Ensure that sink is clear of tools/debris and is in normal operating condition.

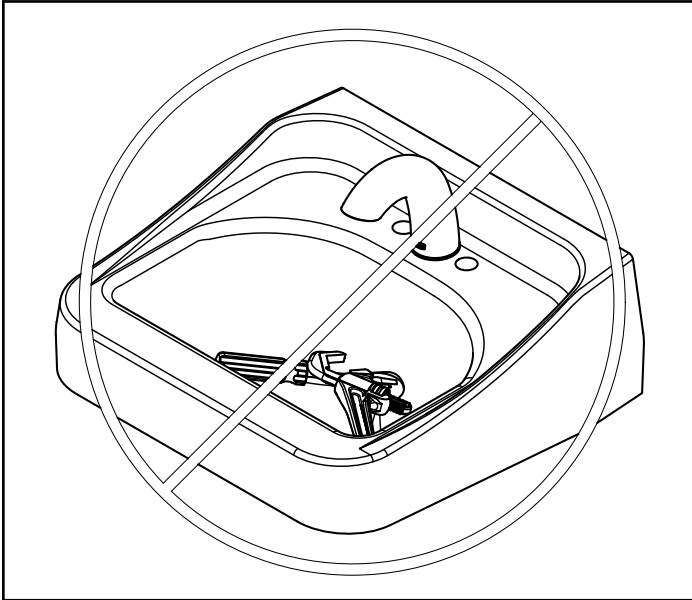

2.8. Connect sensor inline connector or electronics module (for battery-powered, IM installations) to sensor cable from spout.

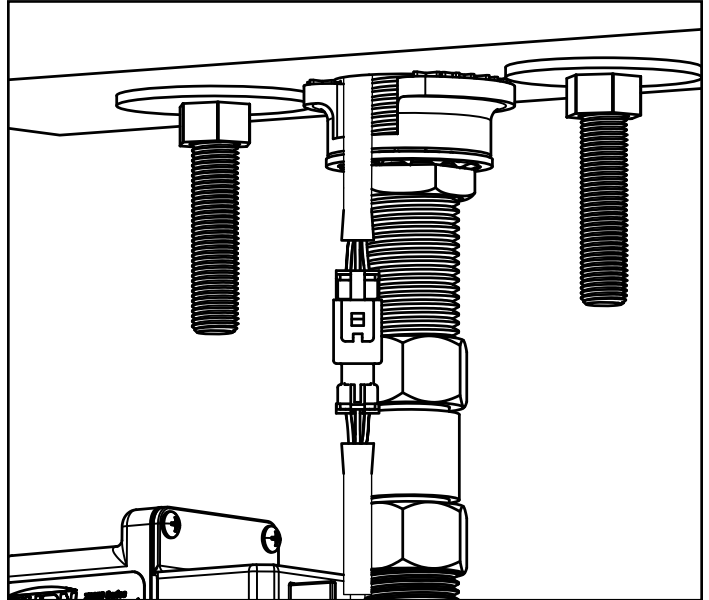

! After the connection is made, do not engage the sensor until its self-calibration is complete. The sensor's self-calibration is complete once the faucet stops flowing water. The sensor's self-calibration can take up to one (1) minute after the connection is made.

Adjustable modes and features selection:

To adjust features from default configuration, you must remove the battery tray. Once battery tray is removed you will see the switches.

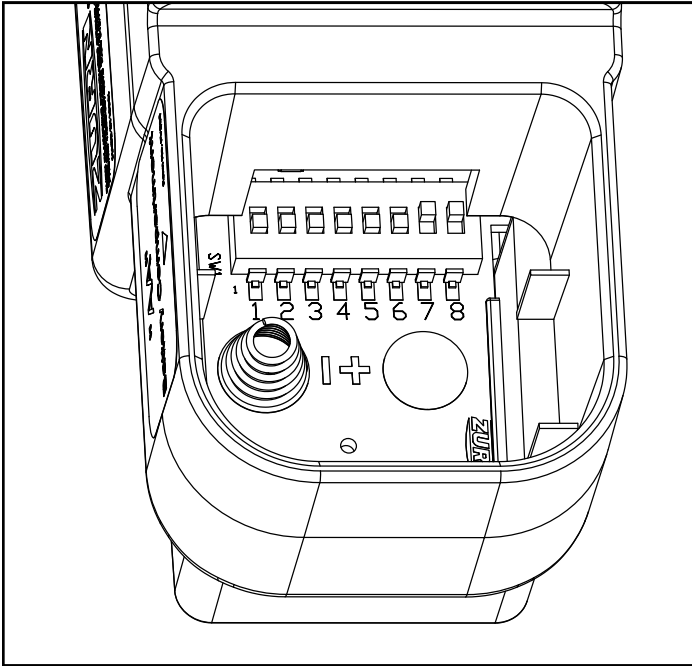

All switches shown in default mode.



Switch Position:	1	2	3	4	5	6	7	8
Purge (Hours)								
Disable:	Off	Off						
12:	On	Off						
24:	Off	On						
48:	On	On						
Time (Seconds)								
30:			Off	Off	Off			
5:			On	Off	Off			
10:			Off	On	Off			
15:			On	On	Off			
60:			Off	Off	On			
Less Time-out:			On	Off	On			
Mode Select								
Sensing Mode:						Off		
Metering Mode:						On		
Sensor Sensitivity								
Low:							Off	Off
Normal:							On	Off
Mode A:							Off	On
Mode B:							On	On

Purge Features:

The purge switches can be configured for 4 modes of operation: Disabled (standard configuration), 12 hour, 24 hours, or 48 hours. Purge water flow duration is 2 minutes. Note: Purge activation occurs every switch selected time (0, 12, 24, or 48 hours) after last activation.

Flow Time:

There are 6 optional time configurations: 30 seconds (standard), 5s, 10s, 15s, 60s, & "Less Time-out". The "Less Time-out" option actually ceases water flow (turns off) after 20 minutes to limit chance of water damage in the event a sink drain becomes blocked.

Sensing Mode (DEFAULT):

During this mode the valve will shut off after hands are removed. If hands are not removed the time out delay will turn off the faucet (ex: standard configuration is 30 seconds) (See Switch Position Diagram shown above)

Metering Mode:

When hands are detected by the sensor, water will run for 'X' seconds (standard configuration is 30 seconds) before turning off. (See Switch Position Diagram shown above)

Sensor Sensitivity: (Default setting: Low):

The 4 sensor sensitivity options are used for varied sink and environmental conditions. The factory default setting should be ideal for most general applications. However, sensor performance can be optimized to adjust for unusual sink finish, material, shape, or unusually bright or dark lighting conditions.

Switch 7 controls the sensitivity

- On (default) is normal sensitivity for most sinks providing max range.
- Off set the sensor to a lower sensitivity level for sinks that cause false activation. The detection range maybe less for all hands.

Switch 8 controls sensor mode

- On (default) enables the mode that filters the effects of flowing in the bottom of problematic sinks. Detection maybe less for some hands.
- Off disable the filter mode, so detection is expanded deeper into the sink for max detection range for all hands. Some sinks may only be able to operate in this mode.

NOTE: After a configuration switch change has been made, disconnect sensor cable from electronics box, wait 30 seconds, then reconnect sensor cable and wait 30 seconds to allow the sensor to tune-in the sink characteristics.

TROUBLESHOOTING GUIDE:

POTENTIAL SITUATIONS	POSSIBLE CAUSES	SUGGESTED SOLUTION TIPS
Faucet is non-responsive	Battery voltage low or no power	Change out batteries or verify power provided by HW6 or ACA
	Sensor and electronic connector cable has bent or broken pins	Check to see if pins are missing, bent, or broken. If yes, then the electronic box needs replaced
	Sensor lens could have surface damage, scratches, or deposit build ups	Inspect the sensor lens underneath the spout tip. May require cleaning with a damp cloth or sensor replacement
	Sensor lens could be obstructed by environmental factors such as high reflective surfaces or bright lighting conditions	If this is the case, then adjust the dip switch settings for sensor sensitivity per the diagram on previous page (switches 7 and 8). Direct sunlight into bowl may make the unit inoperable. Do not allow direct sunlight into bowl
Faucet does not activate after initial installation	Sensor may not have had enough time to calibrate prior to a user or target trying to initiate activation	Disconnect the sensor and electronic box cables and wait for 30 seconds. Reconnect the cables, then wait until the water stops flowing water (up to one (1) minute) before placing hands or a target within the sensor range. You should hear a click of the solenoid once calibration is complete.
Water does not stop	Electronics box cable connector has bent pins that are shorted	Check to see if pins are missing, bent, or broken. If yes, then the electronic box needs replaced.
Ghost Activation	Sensor lens could be obstructed or environmental factors such as high reflective surfaces and/or bright sunlight conditions	"Check/clean sensor lens of any debris or buildup If sunlight or IR interference is a factor, refer to page 7 ""Sensor Sensitivity"" and adjust faucet for Mode B operation."
Sensor faucet is leaking underneath the sink or counter	Mounting hardware is not tightened sufficiently (faucet shank, electronic box, supply hoses, etc)	Check and ensure the nuts and joints are tight and secure from the supply stop all the way to the faucet shank.
	Missing the washer located in the solenoid box nut where it assembles to the faucet shank.	Make sure the water supply stops are shut off. Check to ensure the washer is installed or damaged. If not, install washer. If a washer is installed replace with new.

For further assistance with troubleshooting visit <http://www.zurn.com>

Care and Cleaning Instructions:

- Do not use any abrasive or chemical cleaners to clean the faucets.
- If abrasives or chemicals are used it can lead to dulling of luster, attacking of chrome plating or decorative finishes.
- ONLY use mildly warm soapy water, and then wipe the device dry with a clean/soft towel or cloth.
- Upon cleaning other areas of the restroom be sure the sensor lenses are protected from other cleaning chemicals/solvents to prevent potential damages to the sensor and/or electronics.

Spout Replacement

To replace spout body, you must first turn water off, then remove spout with sensor cable.

Before removing the spout, disconnect the sensor cable below the deck so that the cable head can be pulled up through the deck.

*Take care to press the locking mechanism in prior to disconnecting sensor cable. PULLING APART WITHOUT PRESSING IN THE LOCK MAY DAMAGE THE SENSOR OR CONTROLLER CABLES.

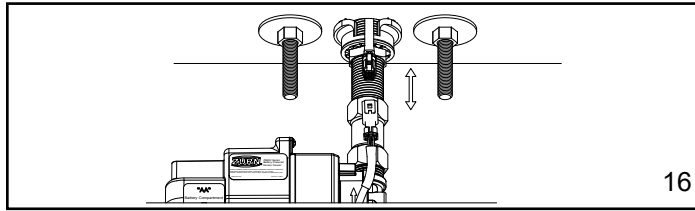

Use supplied 3/32" hex wrench to loosen set screw. Screw will retract into the base to eliminate loss. Using the same hex wrench, depress the ball detent to release spout from base.

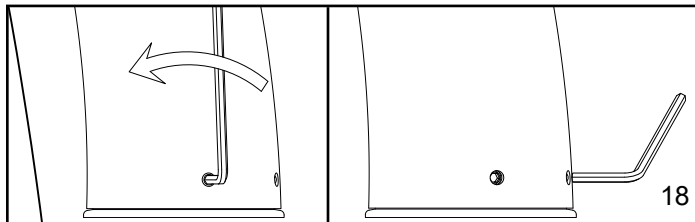

To reinstall faucet, first drop sensor cable of new spout through the front of the base. Lower spout onto base inserting base nipple into spout port.

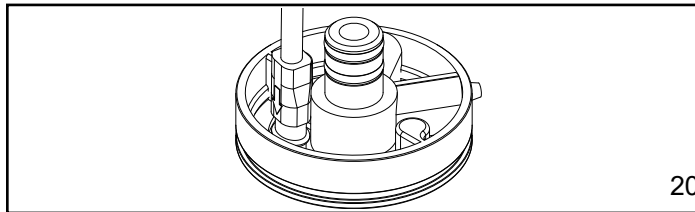

Sensor Assembly Replacement

With spout disengaged, sensor assembly can now be removed by loosening the center screw with supplied M3 Allen wrench. With assembly removed, you can now install new assembly and reassemble your spout.

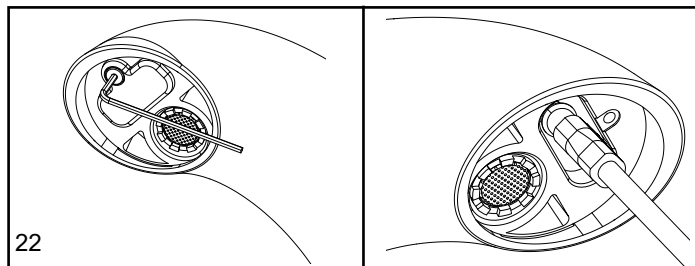

Note location of set screw and spring lock.

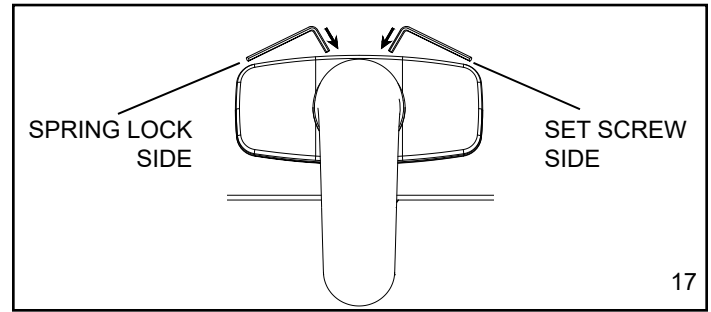

Lift spout and pull sensor cable through deck and base.

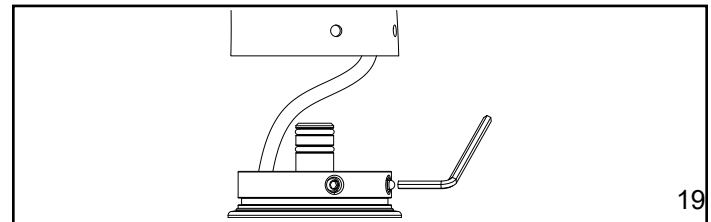

Align spout so that the ball detent is between the 2 holes. Press down and turn clockwise. Use hex wrench to back set screw out to secure spout.

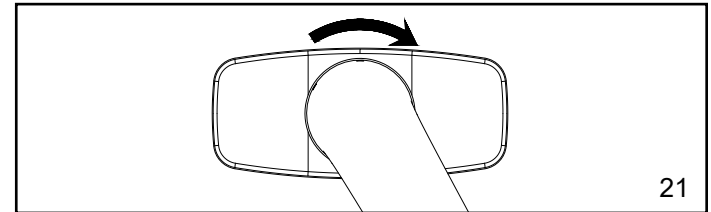

Loosening screw will cause sensor assembly to back out of spout body. It may be necessary to push cable from connector end to aid in sensor assembly removal. Firmly press into pocket and tighten screw. Sensor connector may need to be turned horizontally when first inserting into the spout.

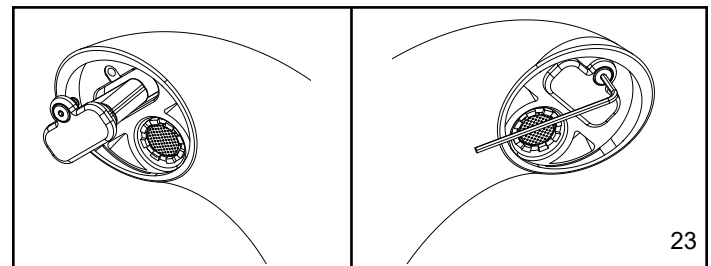

Z6950-XL-S, Z6955-XL-S & Z6950-XL-IM-S Parts List

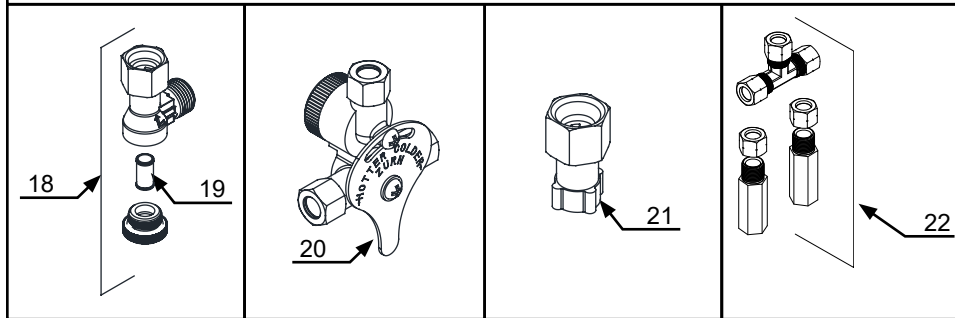
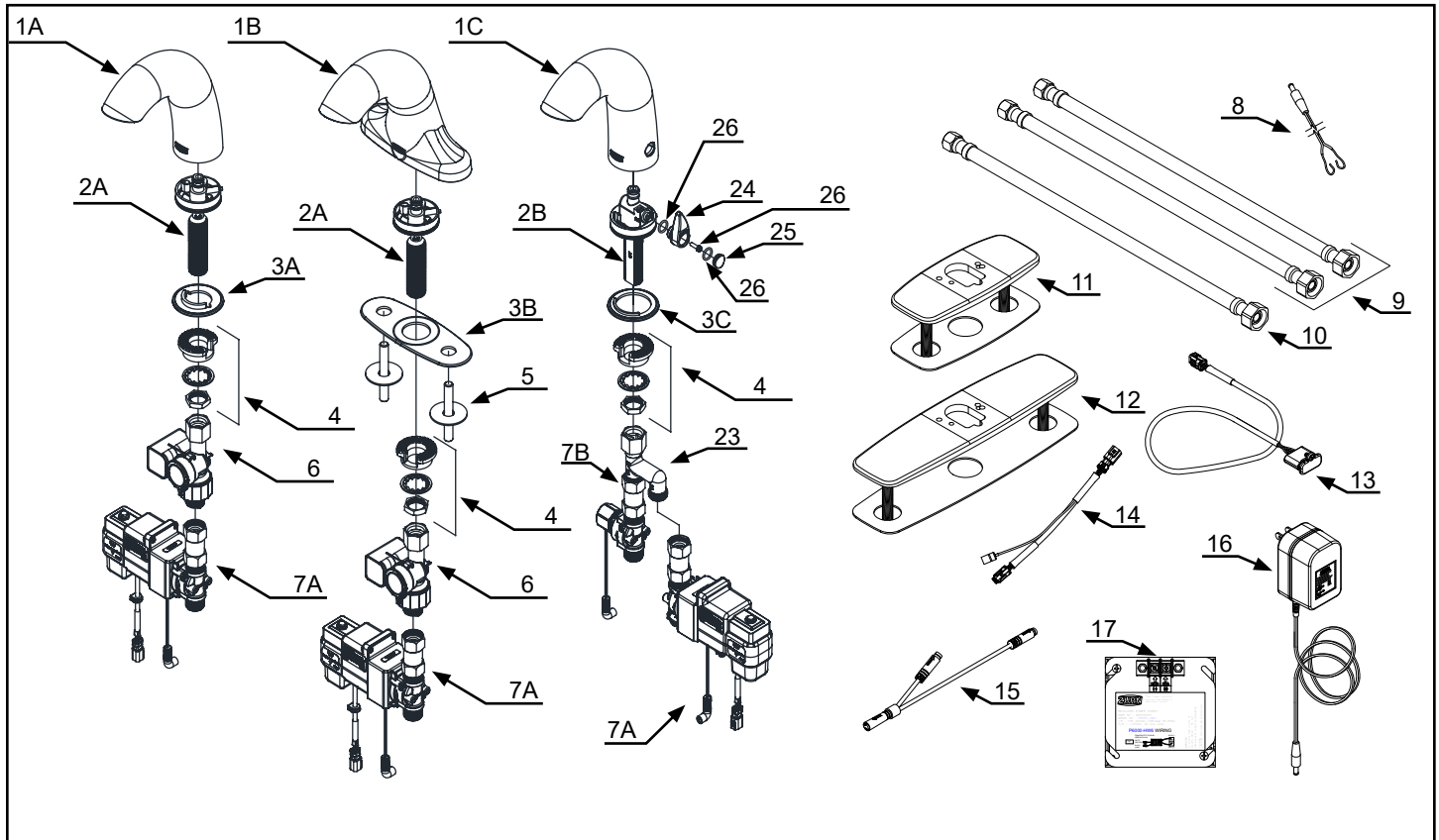

Description	Product No.	Description	Product No.
Z6950 Spout Assembly with Sensor, Item 1A	P6950-XL-S-1	8" Cast Cover Plate w/Gasket, Item 12	P6950-CP8
Z6955 Spout Assembly with Sensor, Item 1B	P6955-XL-S-1	Z6950 Sensor Assembly, Item 13	P6950-XL-EL
Z6950-IM Spout Assembly with Sensor, Item 1C	P6950-XL-S-IM-1	Sensor Inline Connector, Item 14	P6950-XL-DC
Spout shank base for Z6950/Z6955-XL, Item 2A	P6950-XL-B	IM Solenoid Y Connector, Item 15	P6950-XL-YC
Spout shank base for Z6950-XL-IM, Item 2B	P6900-XL-IM-B	Optional Plug-in Power Converter, Item 16	P6900-ACA
Z6950 Spout Base Gasket , Item 3A	P6950-XL-42	-HW6 Power Supply, Item 17	P6900-HW6
Z6955 Spout Base Gasket , Item 3B	P6950-XL-44	Filter Kit, Item 18	P6900-120BC
Z6950-IM Spout Base Gasket , Item 3C	P6950-XL-IM-43	Filter Screen, Item 19	P6900-MV-7
Mounting Kit, Item 4	P6900-43	Mixing Valve with Filter, Item 20	P6900-XL-MV
Widespread Mounting Kit, Item 5	P6912-43M	Composite Mixing Valve Adapter, Item 21	P6900-MV-ADAP
Hydrogenerator Assembly, Item 6	P6900-HYD	Mixing Tee w/Filters and Back Checks, Item 22	P6900-XL-MT
Electronics Box with Solenoid - Z6950/55-XL, Item 7A	P6950-XL-B-L-V2	Y Pipe Adapter for Z6950-XL-IM, Item 23	P6950-XL-Y
Electronics Box with Solenoid - Z6950-XL-IM, Item 7B	P6950-XL-IM-B-L-V2	Mixing Handle for Z6950-XL-IM, Item 24	P6950-XL-H
-CWB Pigtail, Item 8	P6900-CWB	Mixing Handle Plug/Cap for Z6950-XL-IM, Item 25	P6950-XL-C
Stainless Supply Hoses (XL), Item 9	P6900-SH	Handle O-ring and Handle Screw for Z6950-XL-IM, Item 26	P6950-XL-OS
Single Stainless Steel Hose (XL), Item 10	P6900-SSH		
4" Cast Cover Plate w/Gasket, Item 11	P6950-CP4		

