



# Connected Aqua-FIT<sup>®</sup> Battery Powered Faucets Serio Series<sup>™</sup> -W2 Installation, Operation, Maintenance and Parts Manual



Z6955-XL-S-W2



Z6950-XL-S-W2

## Sensor-Operated Lavatory Faucets with Smart Connected Features

- ⚠ **WARNING:** Cancer and Reproductive Harm - [www.P65Warnings.ca.gov](http://www.P65Warnings.ca.gov)
- ⚠ **ADVERTENCIA:** Cáncer y daño reproductivo - [www.P65Warnings.ca.gov](http://www.P65Warnings.ca.gov)
- ⚠ **AVERTISSEMENT:** Cancer et effets néfastes sur la reproduction - [www.P65Warnings.ca.gov](http://www.P65Warnings.ca.gov)

### LIMITED WARRANTY

All goods sold hereunder are warranted to be free from defects in material and factory workmanship for a period of three years from the date of purchase. Decorative finishes warranted for one year. We will replace at no costs goods that prove defective provided we are notified in writing of such defect and the goods are returned to us prepaid at Sanford, NC, with evidence that they have been properly maintained and used in accordance with instructions. We shall not be responsible for any labor charges or any loss, injury or damages whatsoever, including incidental or consequential damages. The sole and exclusive remedy shall be limited to the replacement of the defective goods. Before installation and use, the purchaser shall determine the suitability of the product for his intended use and the purchaser assumes all risk and liability whatever in connection therewith. Where permitted by law, the implied warranty of merchantability is expressly excluded. If the products sold hereunder are "consumer products," the implied warranty of merchantability is limited to a period of three years and shall be limited solely to the replacement of the defective goods. All weights stated in our catalogs and lists are approximate and are not guaranteed.

**NOTICE: READ ENTIRE MANUAL PRIOR TO INSTALLING PRODUCT.**

Rev. F | Date: 03/06/24 | C.N. No. 145900 | Prod./Dwg. No. FV723

Patent [zurn.com/patents](http://zurn.com/patents)

US 1.855.ONE.ZURN CANADA 1.877.892.5216

[ZURN.COM](http://ZURN.COM)

by **ZURN ELKAY** Water Solutions

# Serio Series™ Package Contents

## Z6955-XL-S-W2

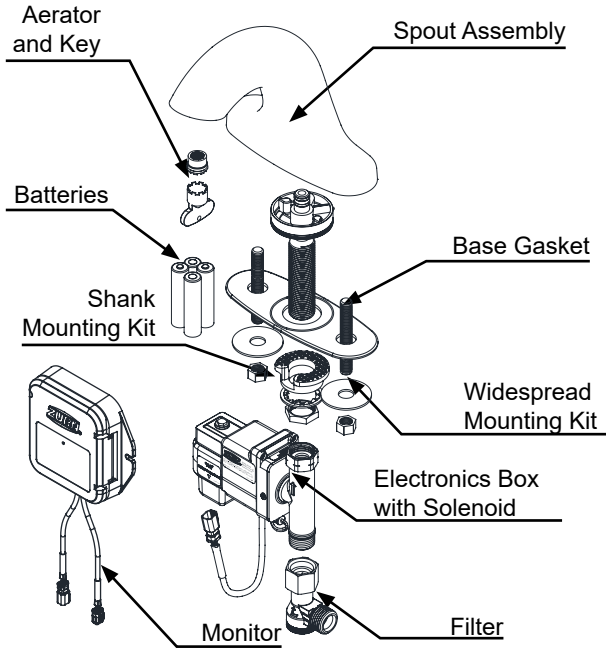

## Z6950-XL-S-W2

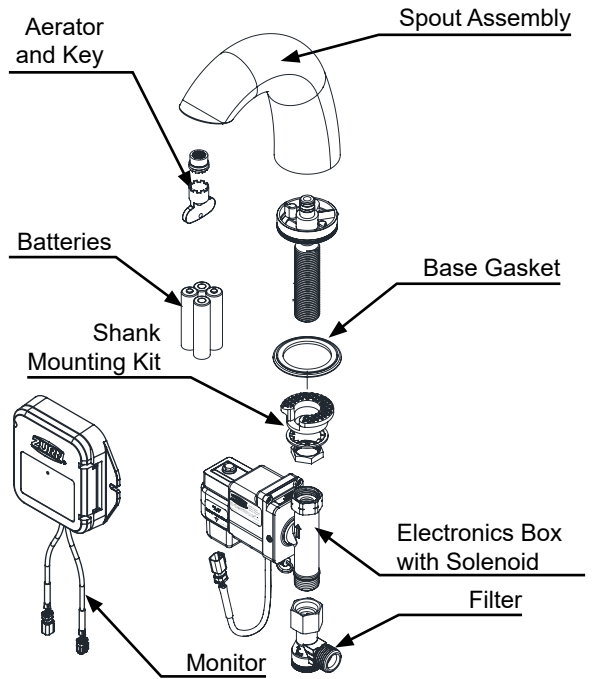

## Required Tools

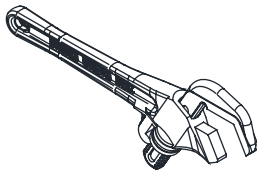

Smooth Jawed  
Wrench

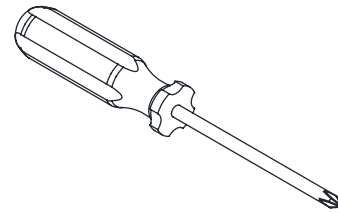

Phillips Head  
Screwdriver

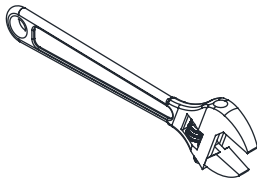

Adjustable Wrench  
(Optional)

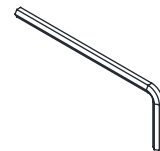

3/32", M3  
Allen Wrenches

## Overview:

Zurn connected faucets transmit data 24/7 to the Zurn plumbSMART™\* web portal and mobile app. Proactively monitor your faucet activations and water usage, receive real-time alerts for preset high and low usage parameters, and access system data for trends and predictive maintenance anytime and anywhere.

AquaSense® sensor faucets are ideal for high-use applications where durability and hands-free operation are necessary. ADA compliant, battery powered, polished chrome-plated cast brass sensor faucet with infrared proximity sensor for retrofit and new construction. Unit is furnished with a standard 1.5 GPM aerator, and mounting hardware.

Zurn Lead Free products (-XL) are designed and manufactured to comply with Section 1417 of the Safe Drinking Water Act (SDWA) which mandates the weighted average lead content of no more than 0.25% of the wetted surface

## Specifications:

Voltage:	6 VDC Series [4 "AA" (Alkaline or Lithium)] for faucet 6 VDC Series [4 "AA" (Alkaline or Lithium)] for monitor
Sensor Range:	Self-calibrated, dependent upon sink depth and finish.
Operating Water Pressure:	10-125 psi
Operational Water Temperature:	33°F to 140°F (1°C to 60°C)
Aerator:	0.5 GPM Vandal-Resistant (Standard)

## Important Safety Information:

- Installer is responsible for ensuring the product is installed and conforms to all plumbing codes and ordinances.
- Do not convert or modify this Zurn product yourself. All warranties will be voided.
- Water supply lines must be sized according to building designer in order to provide adequate water supply for each fixture.
- Flush all water lines prior to making connections.

## Prior to Installation:

Before installing your Zurn® Aqua-FIT® Faucet: the items listed below should already be installed on site.

- Lavatory/sink
- Drain Line
- Hot and cold water supply line or pre-tempered water supply line.
- Installer/Service should not use pipe dope or teflon/thread sealant anywhere on this product, most notably threads and connection points.
- Care shall be taken when installing this product to prevent marring of any exposed or decorative surfaces.

**⚠** *Be sure the water supply is turned on and the sink/lavatory/basin is clear from any objects upon making the sensor to electronics connection initiating the self-calibration feature. The sink must be clear of any and all objects and water supply is turned on in order to calibrate appropriately (calibration time approx 30-60sec) (the system will perform both a wet & dry calibration).*

**NOTE:** The information in this manual is subject to change at any time without notice. Installations may be performed at different times of construction by different individuals. For this reason, these instructions should be left on-site with the facility or maintenance manager.



## Electronic emission notices

This device complies with Part 15 of the FCC Rules. Operation is subject to the following two conditions: (1) this device may not cause harmful interference, and (2) this device must accept any interference received, including interference that may cause undesired operation.

The following information refers to Zurn Smart Connected Products, types: -W1. This equipment has been tested and found to comply with the limits for a Class A digital device, pursuant to Part 15 of the FCC Rules. These limits are designed to provide reasonable protection against harmful interference intended for use in non-residential/non-domestic environments. This equipment generates, uses, and can radiate radio frequency energy and, if not installed and used in accordance with the instructions, may cause harmful interference to radio communications. However, there is no guarantee that interference will not occur in a particular installation. If this equipment does cause harmful interference to radio or television reception, which can be determined by turning the equipment off and on, the user is encouraged to try to correct the interference by one or more of the following measures:

- Reorient or relocate the receiving antenna.
- Increase the separation between the equipment and receiver.
- Connect the equipment into an outlet on a circuit different from that to which the receiver is connected.
- Consult an authorized dealer or service representative for help.

Zurn is not responsible for any radio or television interference caused by using other than specified or recommended cables and connectors or by unauthorized changes or modifications to this equipment. Unauthorized changes or modifications could void the user's authority to operate the equipment.

Responsible party: ZURN INDUSTRIES, LLC 511 W. Freshwater Way, Milwaukee, WI  
U.S.A. 53204 · Ph. 1-855-ONE-ZURN, Fax 919-775-3541

# Spout Installation Instructions

**NOTE:** Before installation, turn off water supplies to existing faucet and remove faucet if replacing an existing device. Clean the faucet basin and clear away debris. Flush all supply lines before connecting the faucet. Failure to do so may result in debris clogging the inlets and/or internal control and mixing valve

1. Carefully screw aerator into spout using included tool.

⚠ Take care to not pinch blue o-ring

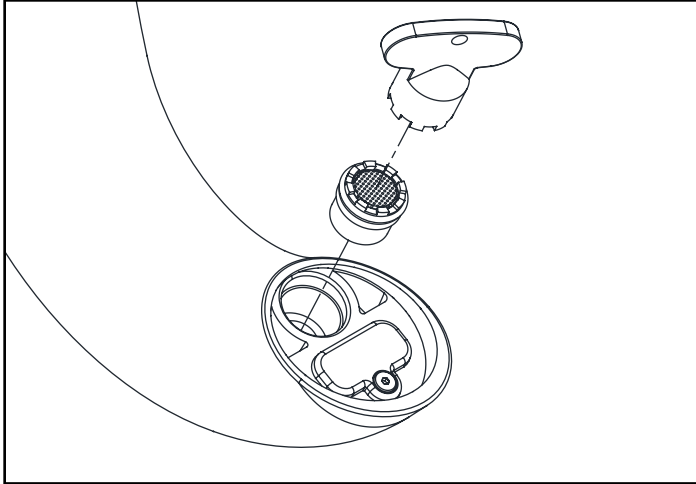

2. Install spout to sink using spout base gasket, plastic mounting washer, star washer and mounting nut.

Note: Faucet location needs to be within 3 feet radius above electrical outlet for ACA configurations.

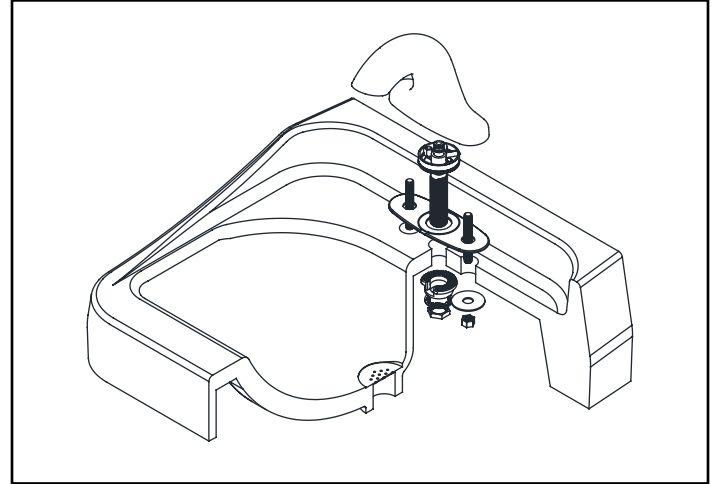

3. Ensure that slot in plastic washer is facing forward.

⚠ Sensor cable should not pass through plastic mounting washer.

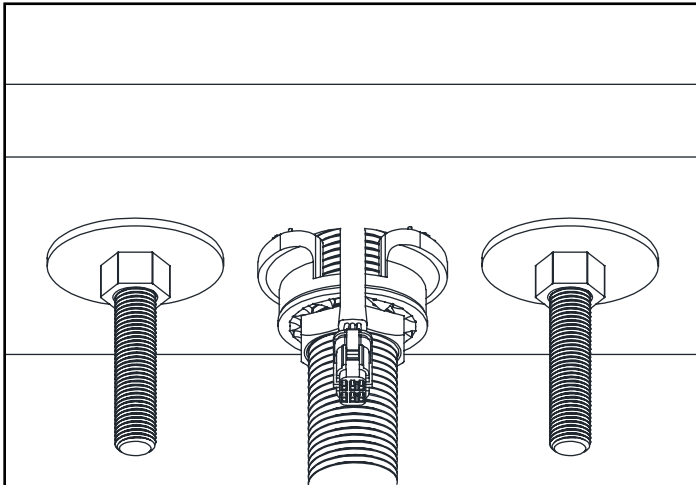

4. Assemble the electronics module

⚠ Do not connect the electronic module to spout

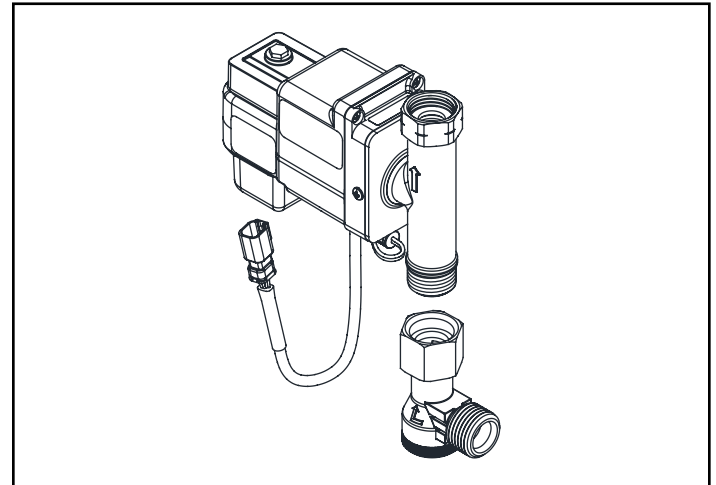

# Monitor & Electronic Module Installation Instructions

1. Install Monitor on wall surface within 2 feet radius of faucet with dry wall anchors & screws or doubled sided VHB tape

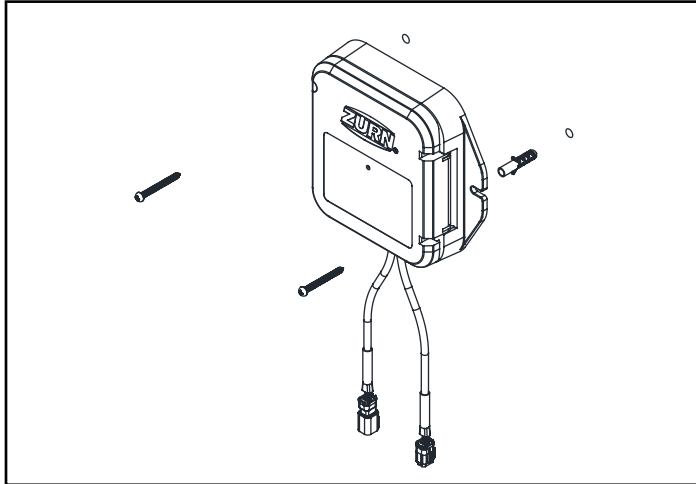

2. Loosen lid screw with supplied 3mm Allen wrench. Open lid and install supplied batteries. Close lid and secure by pressing on the lid tab until it snaps into place. Then tighten lid screw.

Use AA Lithium Batteries or AA Alkaline batteries, but do not mix Lithium with Alkaline.

During servicing or changing of batteries, wipe down Monitor to ensure water does not enter the housing when the lid is opened.

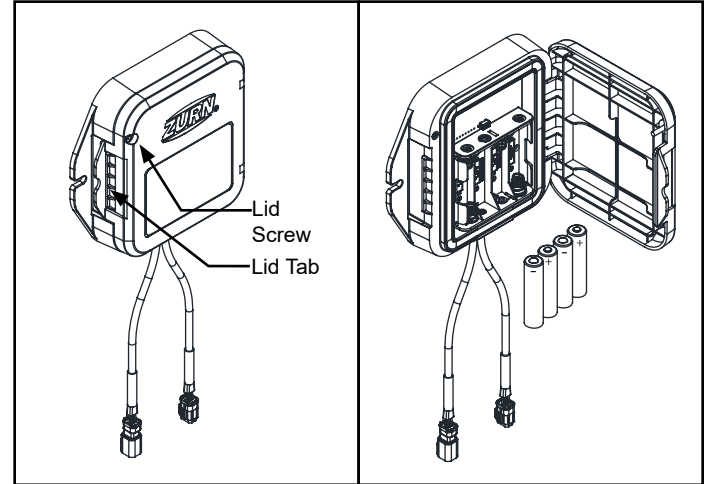

3. Connect monitor and electronics module assembly.  
**⚠ Do not connect cable to the spout at this step.**

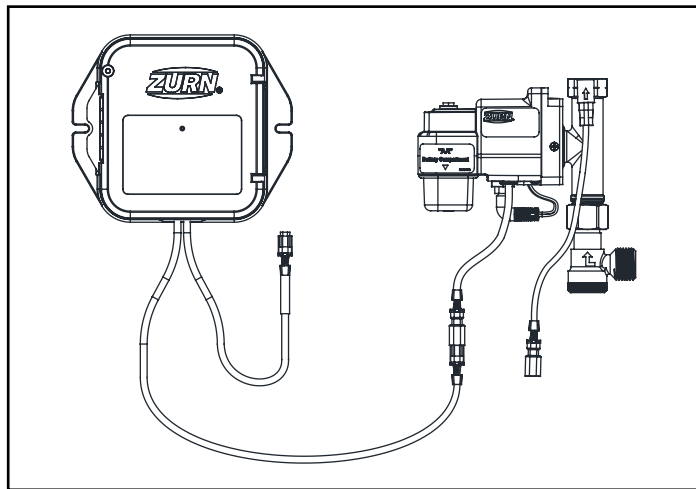

4. Open battery module using supplied 3mm Allen wrench and install supplied batteries in the electronics module. Then close and tighten battery module..

Use AA Lithium Batteries or AA Alkaline batteries, but do not mix Lithium with Alkaline.

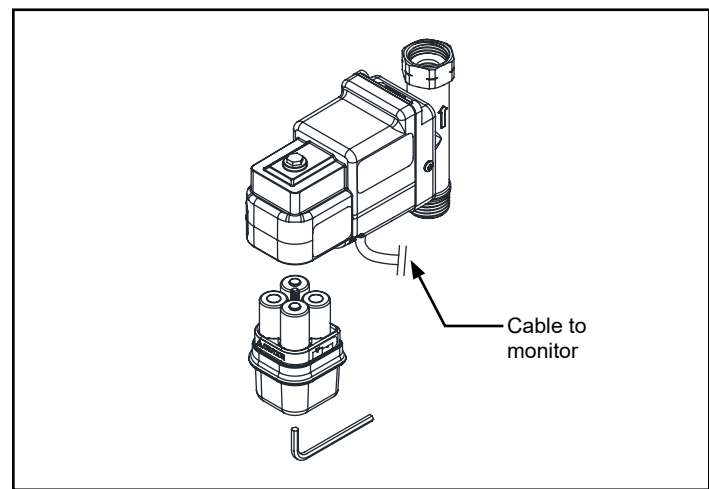

5. Tighten electronics module assembly to shank and connect water line(s).

6. Ensure that sink is clear of tools/debris and is in normal operating condition, and remove protective film from sensor lens has been removed.

7. Turn on water supply(ies).

\*\*\* Water supply must be turned on in order for sensor to perform wet calibration step \*\*\*

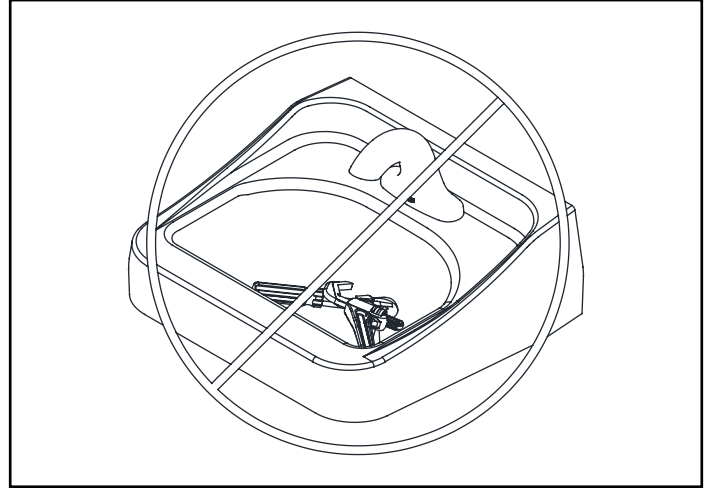
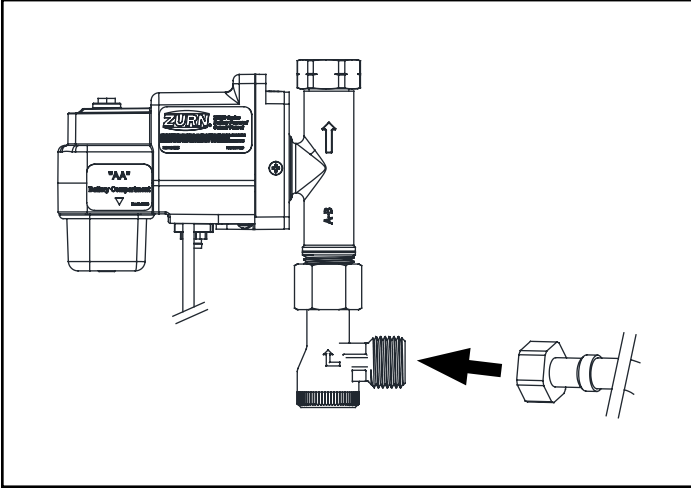

8. Connect sensor cable from spout to monitor.

**⚠** Do not engage the sensor after the connection is made. The sensor will perform automatic calibration, which could flow water for up to 60 seconds. Once the flow of water has stopped, the faucet is calibrated and can be used normally.

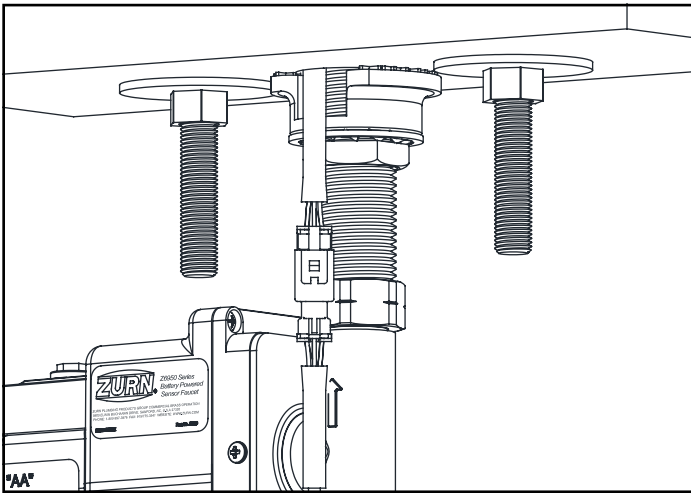

## Care and Cleaning Instructions

---

- Do not use any abrasive or chemical cleaners to clean the faucets.
- If abrasives or chemicals are used it can lead to dulling of luster, attacking of chrome plating or decorative finishes.
- ONLY use mildly warm soapy water, and then wipe the device dry with a clean/soft towel or cloth.
- Upon cleaning other areas of the restroom be sure the sensor lenses are protected from other cleaning chemicals/solvents to prevent potential damages to the sensor and/or electronics.

## Gateway Instruction

---

### Step 1. Request Gateway:

You can request your Ethernet or LTE gateway by visiting

[Zurn.com/plumbsmart-gateway-request](https://www.zurn.com/plumbsmart-gateway-request)

or call Zurn Customer Care at 1-844-987-6737

### Step 2. Cabling, Powering and Connecting Your Device:

1. Connect one end of the RJ45 Ethernet cable (supplied) to the gateway's Ethernet port and plug the cable's other end into the nearest wall port of the building's Ethernet network.
2. Connect the power supply to the power jack.
3. Wait for status LED to go from ON to double flash every second, the LoRa LED to turn ON solid, and the cell LED (if LTE enabled) to flash once every 3 seconds. Should take around 1-2 minutes depending on location. Your gateway is now ready to transmit data from your Zurn connected product.
4. Zurn Gateways have been set to DHCP by default. Please consult local IT support for possible additional access requirements for your network.

### Step 3. Determining general Location for the Zurn Gateway:

- Select a location central to all devices to be connected to this gateway. Place the gateway as high as possible, such as near the top of a wall.
- Avoid obstructions. Thick walls and reflective surfaces, such as metal, weaken the signal between the gateway and other devices.
- The LoRa antenna is an omni-directional antenna, but for best results, mount the device so the LoRa antenna is in a vertical position near the top of a wall. We recommend conducting a site survey to test the signal strength in different locations before you mount the device.

### Step 4. Mounting the Zurn Gateway:

The device ships with a mounting bracket. You will also need:

- Four #6 screws with anchors
  - Screwdriver
  - Drill
1. Determine where you want to mount the device.
  2. Mark where you want the screws to go.
  3. Drill holes for the screws and insert anchors.
  4. Place the mounting bracket and secure it with screws.
  5. Attach the device to the bracket and rotate to lock into place.

## Register in plumbSMART

---

NOTE: Instructions below are duplicated from registration card supplied with monitor

1. Install Zurn Connected Product(s)
2. Install Zurn Gateway per the Gateway Instructions Manual
3. Request plumbSMART Administrator Account at 844-987-6737
4. Zurn creates your Enterprise Account for you! (You will be required to identify your building location, number of floors, and number of rooms.)
5. Log in to [plumbsmart.zurn.com](https://plumbsmart.zurn.com)
6. Register each Connected Product in plumbSMART (Watch How-To Videos to Get Started. Located in the support section inside the portal.)
7. Now, Relax. You're Connected.

# Adjustable modes and features selection

To adjust features from default configuration, you must remove the battery tray. Once battery tray is removed you will see the switches.

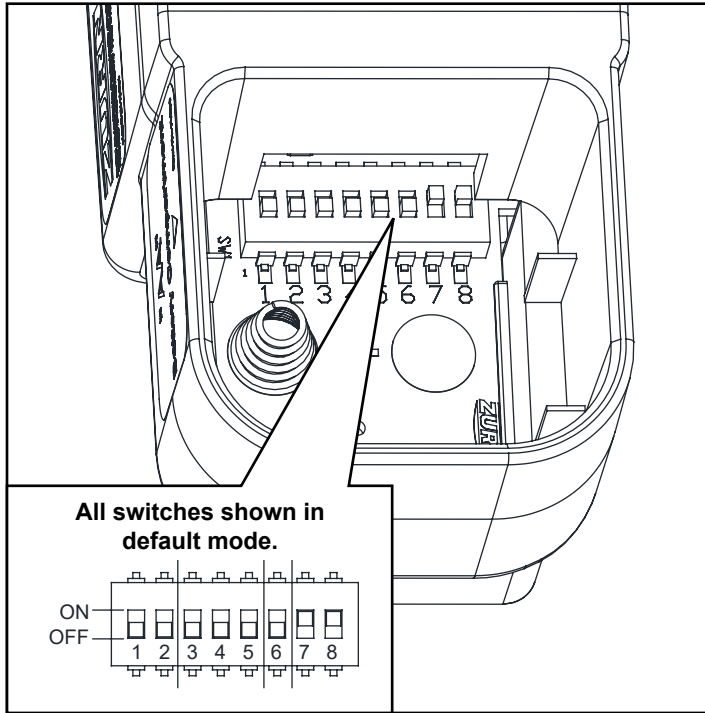

Switch Position:	1	2	3	4	5	6	7	8
<b>Purge (Hours)</b>								
Disable:	Off	Off						
12:	On	Off						
24:	Off	On						
48:	On	On						
<b>Time (Seconds)</b>								
30:			Off	Off	Off			
5:			On	Off	Off			
10:			Off	On	Off			
15:			On	On	On			
60:			Off	Off	On			
Less Time-out			On	Off	On			
<b>Mode Select</b>								
Sensing Mode:						Off		
Metering Mode:						On		
<b>Sensor Sensitivity</b>								
Low:							Off	
Normal:							On	
Mode A:								Off
Mode B:								On

### Purge Features:

The purge switches can be configured for 4 modes of operation: Disabled (standard configuration), 12 hour, 24 hours, or 48 hours. Purge water flow duration is 2 minutes. Note: Purge activation occurs every switch selected time (0, 12, 24, or 48 hours) after last activation.

### Flow Time:

There are 6 optional time configurations: 30 seconds (standard), 5s, 10s, 15s, 60s, & "Less Time-out". The "Less Time-out" option actually ceases water flow (turns off) after 20 minutes to limit chance of water damage in the event a sink drain becomes blocked.

### Sensing Mode (DEFAULT):

During this mode the valve will shut off after hands are removed. If hands are not removed the time out delay will turn off the faucet (ex: standard configuration is 30 seconds) (See Sensing & Metering Mode flow chart above page)

### Metering Mode:

When hands are detected by the sensor, water will run for 'X' seconds (standard configuration is 30 seconds) before turning off. (See Sensing & Metering Mode flow chart on following page)

### Sensor Sensitivity: (Default setting: Low):

There are 4 sensitivity options, which can be selected to achieve the optimal detection performance related to the sink material, shape, & finish. The faucet sensor sensitivity is configured during pack-out but the mode can be changed upon installation to optimize the performance within the sink. Sensor sensitivity and sensor detection Modes A & B may be tried for various lighting conditions, sink materials and shape.

Switch 7 controls the sensitivity

- On (default) is normal sensitivity for most sinks providing max range.
- Off set the sensor to a lower sensitivity level for sinks that cause false activation. The detection range maybe less for all hands.

Switch 8 controls sensor mode

- On (default) enables the mode that filters the effects of flowing in the bottom of problematic sinks. Detection maybe less for some hands.
- Off disable the filter mode, so detection is expanded deeper into the sink for max detection range for all hands. Some sinks may only be able to operate in this mode.



**NOTE:** After a configuration switch change has been made. Disconnect sensor cable from electronics box, wait 30 seconds, then reconnect sensor cable and wait 30 additional seconds to allow the sensor to tune-in the sink characteristics. Calibration includes characterizing the sink with water running into the bowl. This could be 5 to 60 seconds depending on configuration.

## Trouble Shooting: Faucet

Problem	Possible Cause	Corrective Action
Faucet is non-responsive	Battery voltage low or no power.	Change out batteries or verify power provided by ACA
	Sensor and electronic connector cable has bent or broken pins.	Check to see if pins are missing, bent, or broken. If yes, then the electronic box needs to be replaced
	Sensor lens could have surface damage, scratches, or deposit build ups.	Inspect the sensor lens underneath the spout tip. May require cleaning with a damp cloth or sensor replacement
	Sensor lens could be obstructed by environmental factors such as highly reflective surfaces or bright lighting conditions.	<p>If this is the case, then adjust the dip switch settings for sensor sensitivity per the diagram on previous page (switches 7 and 8). Direct sunlight into sink may make the unit inoperable. Do not allow direct sunlight into sink.</p> <p>If one mode does not help try one of the following:                      -switching 7 to Off to set the sensor to the lowest sensitivity level (detection range may be less for all hand types).                      -switching to alternate mode using switch 8; mode A or B depending on current configuration</p> <p>Reset sensor after dip switch changes.</p>
Faucet does not activate after initial installation	Sensor may not have had enough time to calibrate prior to a user or target trying to initiate activation.	Disconnect the sensor and electronic box cables and wait for 30 seconds. Reconnect the cables, but allow for another 30 seconds before placing hands or a target within the sensor range. You should hear a click of the solenoid once calibration is complete.
	Check if protective film was removed from lens.	
Water does not stop	Electronics box cable connector has bent pins that are shorted	Check to see if pins are missing, bent, or broken. If yes, then the electronic box needs to be replaced.
Ghost Activation	Sensor lens could be obstructed or environmental factors such as highly reflective surfaces and/or bright sunlight conditions.	<p>Check/clean sensor lens of any debris or buildup. If sunlight or IR interference is a factor, refer to page 7 "Sensor Sensitivity" and adjust faucet for Mode B operation. Also, decreasing the sensitivity setting (switch 7) may help.</p> <p>Reset sensor after dip switch changes.</p>
Sensor faucet is leaking underneath the sink or counter	Mounting hardware is not tightened sufficiently (faucet shank, electronic box, supply hoses, etc)	Check and ensure the nuts and joints are tight and secure from the supply stop all the way to the faucet shank.
	Missing the washer located in the solenoid box nut where it assembles to the faucet shank.	Make sure the water supply stops are shut off. Check to ensure the washer is installed or damaged. If not, install washer. If a washer is damaged, replace with new.

For further assistance with troubleshooting visit <http://www.zurn.com>

# Trouble Shooting: LoRa Monitor

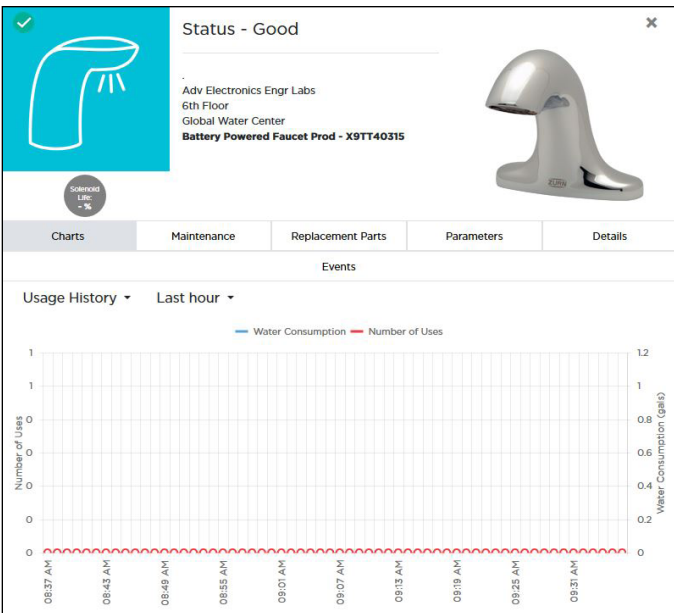
Problem	Corrective Action
<p>“Device Not Communicating” posted in plumbSMART</p> 	<p><b>Step 1</b> Verify batteries installed in LoRa Monitor electronics and have sufficient charge. Install new batteries, as needed. Alert on product’s page in plumbSMART should clear within 1 hour or on next faucet activation. (Refresh web page by clicking on reload icon in the browser to clear the alert.)</p> <p><b>Step 2</b> If problem still present, verify gateway is within range of LoRa Monitor and functioning (see Gateway Troubleshooting section)</p> <p><b>Step 3</b> If problem still present, verify plumbSMART subscription status on product page’s Details tab listed as “Activated”</p> <p><b>NETWORK:</b> Senet <b>SUBSCRIPTION STATUS:</b> <i>Activated</i> <b>LAST HEARD FROM:</b> 07/14/2020, 04:29 PM CDT</p> <p>If listed as “Deactivated”, contact Zurn Custom Service at 1.855.ONE.ZURN (1.855.663.9876) for assistance.</p>
<p>“Status – Good” posted in plumbSMART and faucet not actuating</p> 	<p><b>Step 1</b> Verify LoRa Monitor’s cables are connected to IR sensor and Faucet actuator electronics. Restore proper electrical connection, as needed.</p> <p><b>Step 2</b> Test activate the faucet.</p> <p>If problem persists, see Faucet Troubleshooting section in this guide for other steps.</p>
<p>“Status – Good” posted in plumbSMART and faucet actuates but usage event data not appearing in plumbSMART Charts</p> 	<p><b>Step 1</b> Verify gateway is powered and LoRa Status LED is ON. If not, apply power per Zurn Gateway Installation Guide or see Gateway Troubleshooting section in this guide of other steps.</p> <p><b>Step 2</b> If problem still present, verify plumbSMART subscription status on product page’s Details tab listed as “Activated”</p> <p><b>NETWORK:</b> Senet <b>SUBSCRIPTION STATUS:</b> <i>Activated</i> <b>LAST HEARD FROM:</b> 07/14/2020, 04:29 PM CDT</p> <p>If listed as “Deactivated”, contact Zurn Customer Service at 1.855.ONE.ZURN (1.855.663.9876) for assistance.</p> <p><b>Step 3</b> If problem still present, the LoRa Monitor electronics may be faulty. Contact Zurn Customer Service at 1.855.ONE.ZURN (1.855.663.9876) for assistance with additional troubleshooting steps and, if needed, unit replacement.</p>

For further assistance with troubleshooting, visit <https://plumbsmart.zurn.com/app/training>

# Trouble Shooting: Gateway

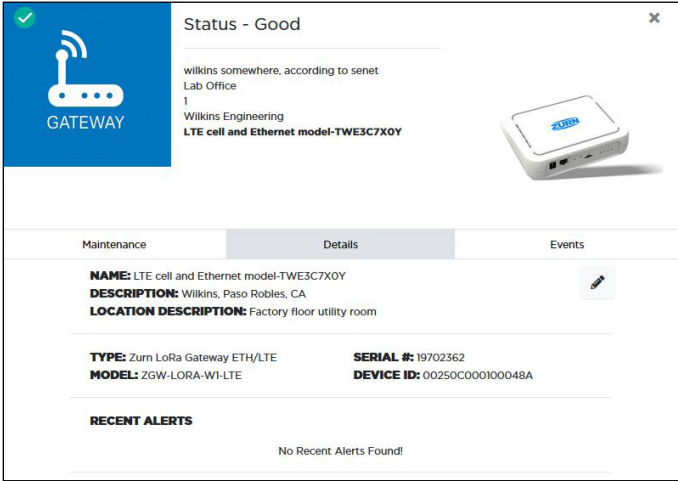
Problem	Corrective Action
<p>“Status – Good” posted in plumbSMART and faucet actuation event data not appearing in plumbSMART (&lt; 2 hours) or “Device Not Communicating” warning or severe alert posted in plumbSMART for all devices (&gt; 3 hours)</p> 	<p><b>Step 1</b> Verify gateway Status LED flashes twice every 2 seconds. If LED is OFF or ON solid, power cycle the gateway and wait for no more than 5 minutes for unit to initialize and connect.</p> <p><b>Step 2</b> After initialization is finished, LORA LED should turn ON solid within an additional minute.</p> <p><b>Step 3</b> If LORA LED does not turn ON solid and ethernet cable connected, contact facility IT administrator to modify port rules to allow Zurn gateway to access the internet via local router.</p> <p>If gateway model is ETH/LTE, visually verify SIM card is installed in designated slot on the side of gateway. If unit has a SIM card, then disconnect ethernet cable and power cycle the gateway and wait for unit to initialize and connect. LORA LED should turn ON solid after initialization.</p> <p><b>Step 4</b> If problem still present, move gateway closer to LoRa monitors and/or verify gateway mounting, orientation and connections comply with requirements listed in Zurn Gateway Installation Guide.</p> <p>Contact Zurn Customer Service at 1.855.ONE.ZURN (1.855.663.9876) for assistance with additional troubleshooting steps.</p>

For further assistance with troubleshooting, visit <https://plumbsmart.zurn.com/app/training>

# Trouble Shooting: plumbSMART

Problem	Corrective Action
<p>Usage data presented in Water Usage Chart does not match expected usage.</p>	<p><b>Step 1</b> Confirm installed aerator model's gallons/minute specification matches parameter setting in plumbSMART product page "Parameters" tab. If factory-original aerator is installed, reset parameter value to factory default and click Update.</p> <div data-bbox="829 352 1505 512" style="border: 1px solid black; padding: 5px;"> <p><b>AERATOR FLOW RATE</b> ⓘ</p> <p>Aerator Flow Rate ⓘ <span style="float: right;">0.5</span></p> <p style="text-align: right; font-size: small;">gpm (Default: 0.5)</p> <p style="text-align: right;"> <input type="button" value="Reset to Defaults"/> <input type="button" value="Update"/> </p> </div> <p><b>Step 2</b> Test activate the faucet and confirm single usage event data is properly presented in Chart</p> <p><b>Step 3</b> If problem still present, contact building maintenance to verify sufficient water pressure in lines.</p> <p><b>Step 4</b> If problem persists, the LoRa Monitor may be paired to the incorrect fixture model. Verify product image and model number from plumbSMART product page "Details" tab against model number cited on product literature and packaging.</p> <p>If incorrect, contact Zurn Custom Service at 1.855.ONE.ZURN (1.855.663.9876) for assistance.</p>
<p>"High Daily Faucet Activate Rate" posted in plumbSMART</p> <div data-bbox="115 1045 789 1262" style="border: 1px solid black; padding: 5px;">  </div>	<p><b>Step 1</b> Verify faucet is not falsely triggering. See Faucet Troubleshooting section for appropriate diagnostic steps.</p> <p><b>Step 2</b> Test activate the faucet and confirm single usage event data is properly presented in Chart.</p> <p>If problem persists, see Faucet Troubleshooting section in this guide for additional steps.</p>
<p>LoRa Monitor not listed in plumbSMART.</p>	<p><b>Step 1</b> Follow registration steps in plumbSMART to activate the connected product.</p>

For further assistance with troubleshooting, visit <https://plumbsmart.zurn.com/app/training>

## Spout Replacement

To replace spout body, you must first turn water off, then remove spout with sensor cable.

Before removing the spout, disconnect the sensor cable below the deck so that the cable head can be pulled up through the deck.

\*Take care to press the locking mechanism in prior to disconnecting sensor cable. PULLING APART WITHOUT PRESSING IN THE LOCK MAY DAMAGE THE SENSOR OR CONTROLLER CABLES.

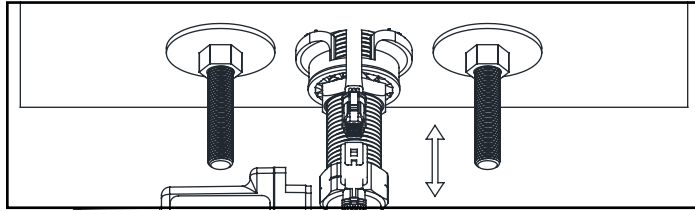

Use supplied 3/32" hex wrench to loosen set screw. Screw will retract into the base to eliminate loss. Using the same hex wrench, depress the ball detent to release spout from base.

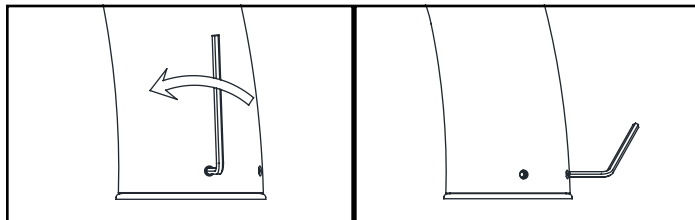

To reinstall faucet, first drop sensor cable of new spout through the front of the base. Lower spout onto base inserting base nipple into spout port.

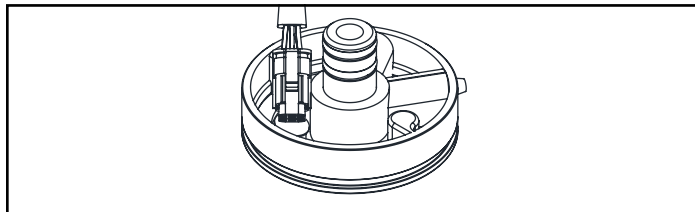

## Sensor Assembly Replacement

With spout disengaged, sensor assembly can now be removed by loosening the center screw with supplied M3 Allen wrench. With assembly removed, you can now install new assembly and reassemble your spout.

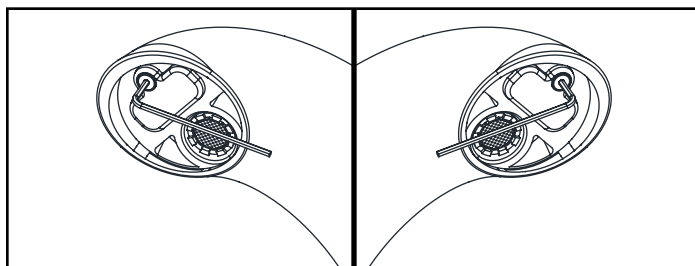

## Accessing the Solenoid

To service solenoid use Phillips head screw driver to remove the screws on both sides of the electronics box.

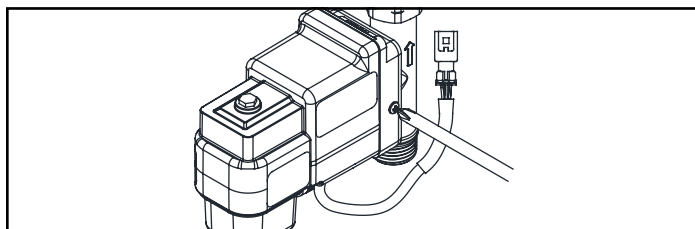

Note location of set screw and spring lock.

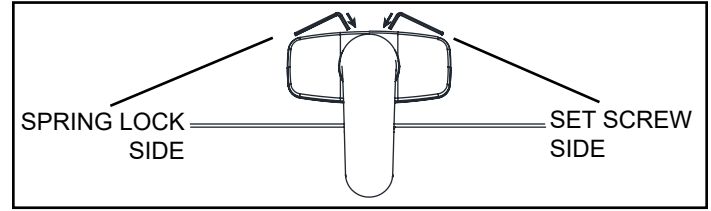

Lift spout and pull sensor cable through deck and base.

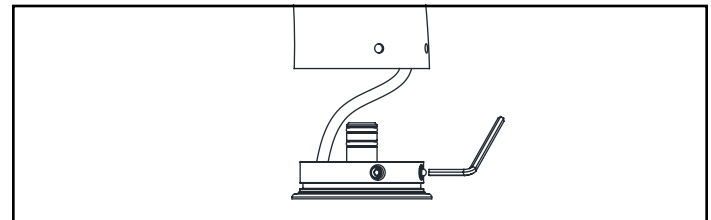

Align spout so that the ball detent is between the 2 holes. Press down and turn clockwise. Use hex wrench to back set screw into to secure spout.

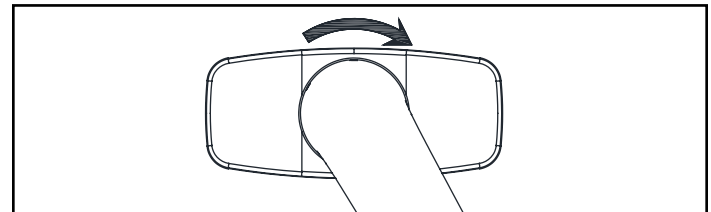

Loosening screw will cause sensor assembly to back out of spout body. It may be necessary to push cable from connector end to aid in sensor assembly removal. Firmly press into pocket and tighten screw. Sensor connector may need to be turned horizontally when first inserting into the spout.

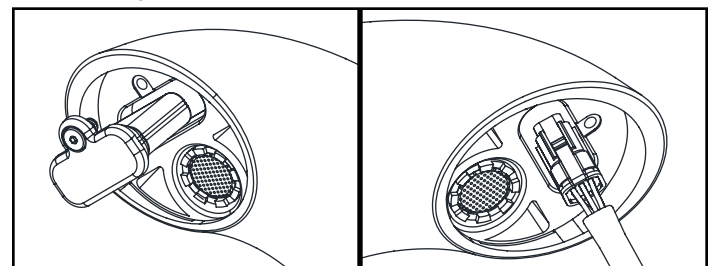

With screws removed, the electronics box can slide off and allow access to the solenoid for service.

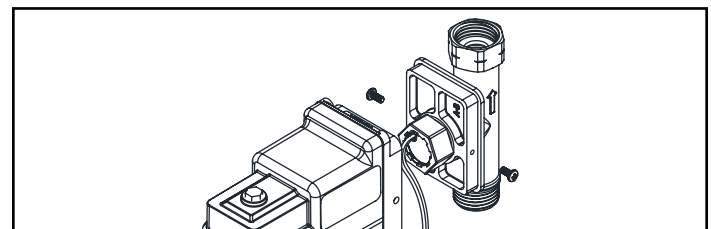

# Filter and Mixing Valve Installation

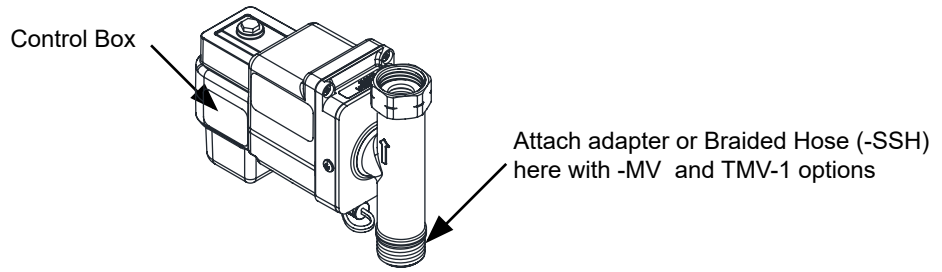

## P6900-120BC, Filter in standard faucet installation

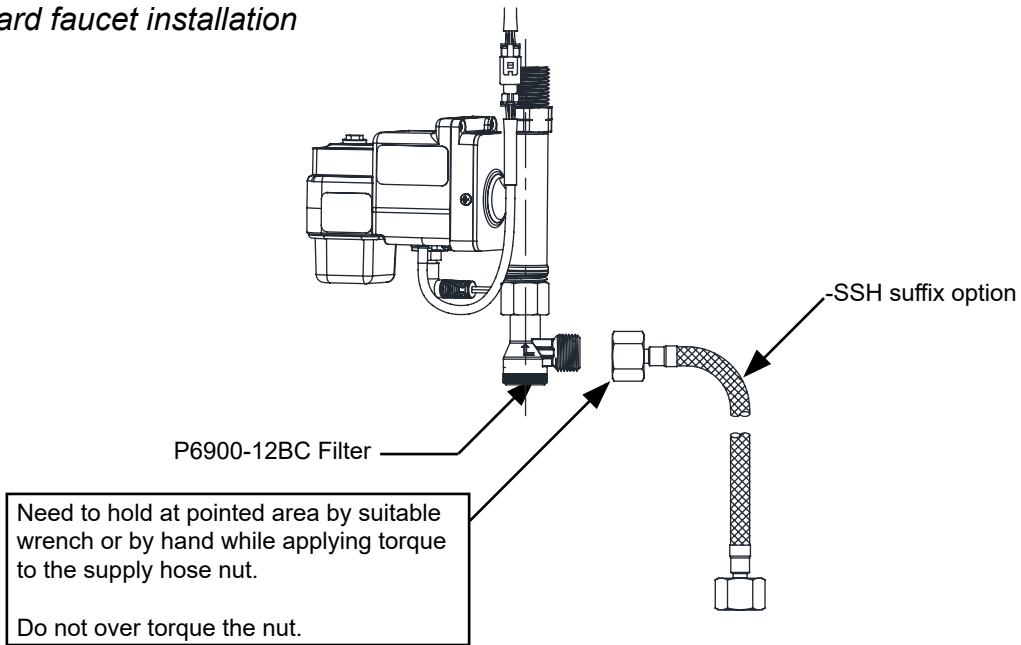

## P6900-MV-ADAP [Supplied Adapter] with -MV, and -TMV-1 Options

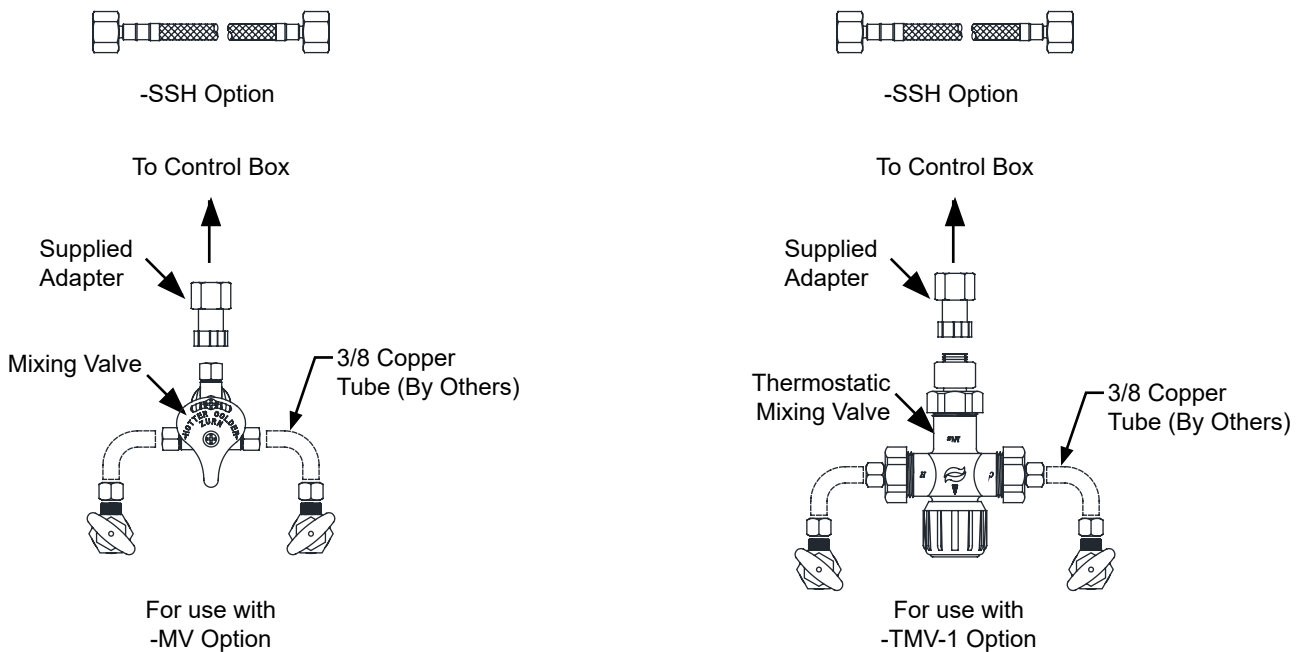

## Z6950-XL & Z6955-XL Parts List

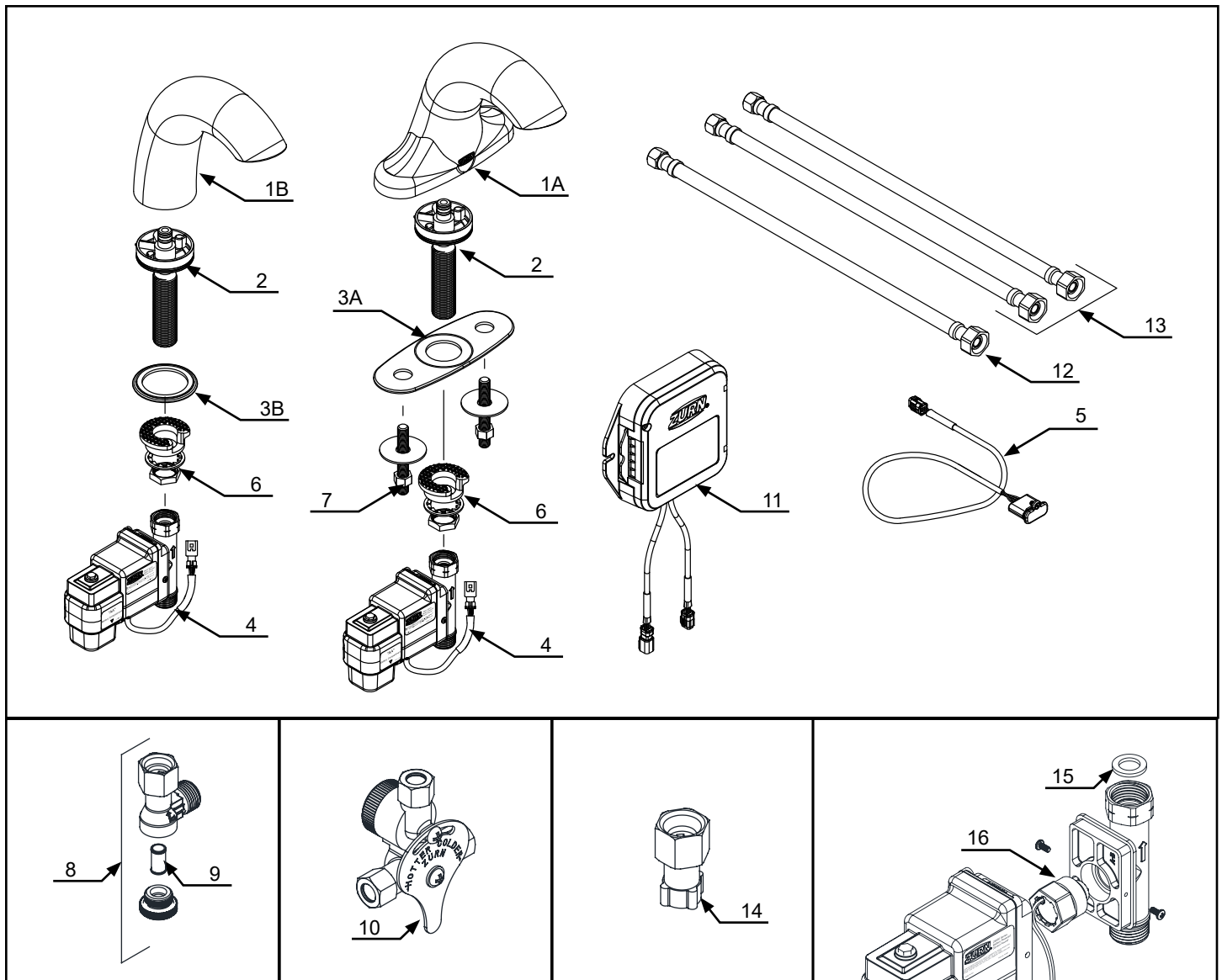

Description	Product No.
Z6955 Spout Assembly with Sensor, Item 1A	P6955-XL-S-1
Z6950 Spout Assembly with Sensor, Item 1B	P6950-XL-S-1
Spout shank base, Item 2	P6950-XL-B
Z6955 Spout base gasket, Item 3A	P6950-XL-44
Z6950 Spout base gasket, Item 3B	P6950-XL-42
Electronics Box with Solenoid, Item 4	<a href="#">P6950-XL-B-L-V2</a>
Z6955 Sensor Assembly, Item 5	P6950-XL-EL
Mounting Kit, Item 6	P6950-43
Widespread Mounting Kit, Item 7	P6912-43M
Filter Kit, Item 8	<a href="#">P6900-120BC</a>
Filter Screen, Item 9	P6900-MV-7
Mixing Valve with Filter, Item 10	<a href="#">P6900-MV-XL</a>

Description	Product No.
Single Stainless Supply Hose (XL), Item 12	P6900-SSH
Stainless Supply Hose (XL), Item 13	P6900-SH-XL
Composite Mixing Valve Adapter, Item 14	P6900-MV-ADAP
Shank Connection Gasket, Item 15	P6900-SG
Solenoid Rebuilt Kit (Diaphragm, Plunger and Plunger spring), Item 16	<a href="#">P6950-SRK-V2</a>
Smart Connected Faucet Retrofit Kit, Item 11	P6900-RK-W1/W2

Rev. F | Date: 03/06/24 | C.N. No. 145900 | Prod./Dwg. No. FV723

Patent zum.com/patents

US 1.855.ONE.ZURN CANADA 1.877.892.5216

[ZURN.COM](http://ZURN.COM)

by **ZURN ELKAY** Water Solutions