



Aquaflush[®] Z6100 Series

Aquaflush Concealed Flushometer

Installation, Operation, Maintenance
and Parts Manual

Patented and Patents Pending



Z6140



Z6195

Aquaflush Concealed Closet/Urinal Systems

Z6140	Z6154
Z6142	Z6155
Z6143	Z6190
Z6144	Z6195
Z6150	Z6196
Z6152	

⚠ **WARNING:** Cancer and Reproductive Harm - www.P65Warnings.ca.gov

⚠ **ADVERTENCIA:** Cáncer y daño reproductivo - www.P65Warnings.ca.gov

⚠ **AVERTISSEMENT:** Cancer et effets néfastes sur la reproduction - www.P65Warnings.ca.gov

LIMITED WARRANTY

All goods sold hereunder are warranted to be free from defects in material and factory workmanship for a period of three years from the date of purchase. Decorative finishes warranted for one year. We will replace at no costs goods that prove defective provided we are notified in writing of such defect and the goods are returned to us prepaid at Sanford, NC, with evidence that they have been properly maintained and used in accordance with instructions. We shall not be responsible for any labor charges or any loss, injury or damages whatsoever, including incidental or consequential damages. The sole and exclusive remedy shall be limited to the replacement of the defective goods. Before installation and use, the purchaser shall determine the suitability of the product for his intended use and the purchaser assume all risk and liability whatever in connection therewith. Where permitted by law, the implied warranty of merchantability is expressly excluded. If the products sold hereunder are "consumer products," the implied warranty of merchantability is limited to a period of three years and shall be limited solely to the replacement of the defective goods. All weights stated in our catalogs and listed are approximate and are not guaranteed.

Aquaflush Rough-In, Product Specification, Models and Options

ENGINEERING SPECIFICATION: ZURN Aquaflush Concealed

Closet Flush Valve – Concealed, quiet diaphragm-type, rough brass flushometer valve with chloramine resistant, dual seal diaphragm with a clog resistant by-pass. Complete with a non-hold-open and no leak handle feature, high back pressure vacuum breaker, flush tube, elbow flush connections, wall escutcheon, fixture spud escutcheon, and fixture spud securing nut. Control stop has internal siphon-guard protection. Internal seals are made of chloramine resistant materials.

MODELS

- Z6140 – 1-1/2" Water Closet valve with back spud connection
- Z6152 – 1-1/2" Water Closet valve with back spud connection
- Z6190 – 1-1/4" Urinal Valve with top spud connection
- Z6195 – 3/4" Urinal Valve with top spud connection

FLOWS

- WS1 Low Consumption
1.0 Gal. for Urinal, 1.6 Gal. for Water Closet
- WS Water Saver
1.5 Gal. for Urinal, 3.5 Gal. for Water Closet (Standard Flow)
- FF Full Flow
3.0 Gal. for Urinal, 4.5 Gal. for Water Closet

OPTIONS

- _____ -BG BioCare ADA Handle
- _____ -J Metal Oscillating ADA Handle
- _____ -L 1" [25] Metal Push Button
- _____ -L3 3" [76] Metal Push Button
- _____ -YB Sweat Solder Kit
- _____ Other

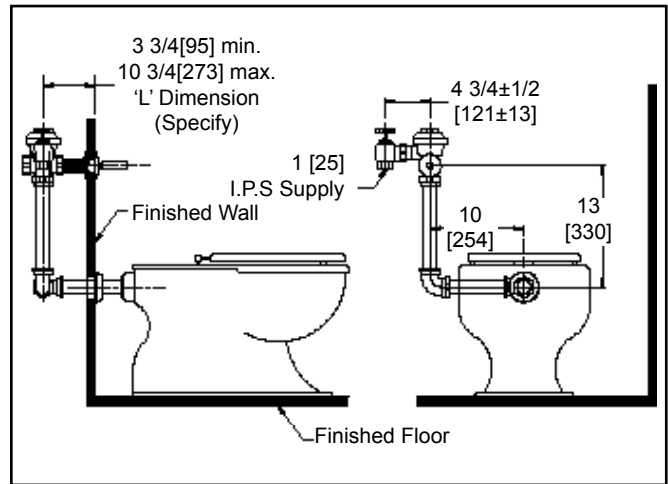

Models: Z6140AV
-WS1 (water saver) 1.6 Gal. Low Consumption

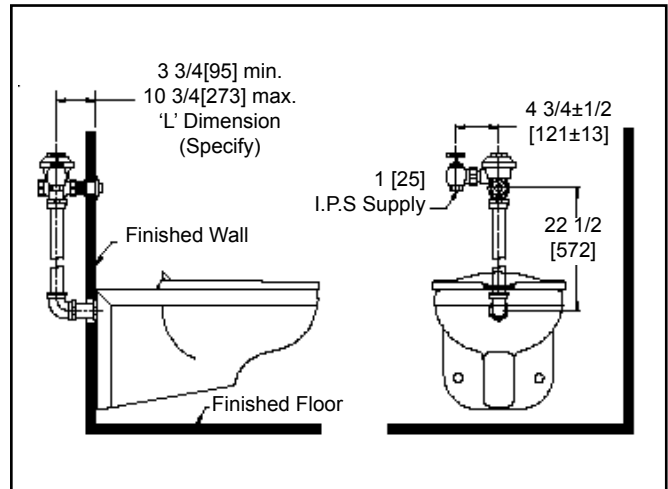

Models: Z6152AV
-WS1 (water saver) 1.6 Gal. Low Consumption

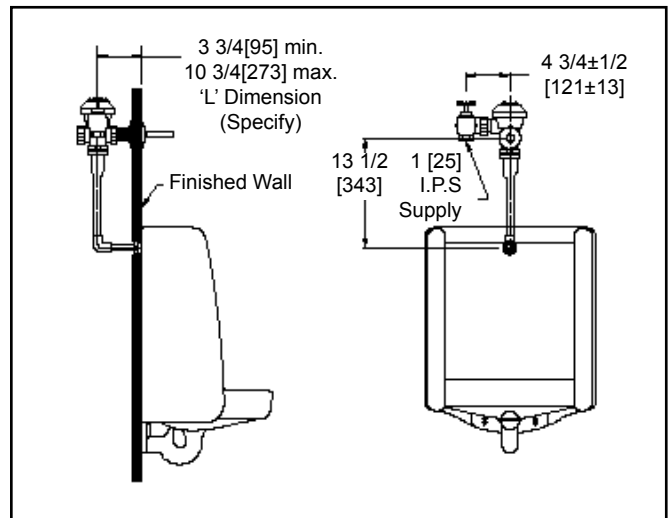

Models: Z6190AV (1-1/4" urinal flush valve)
Z6195AV (3/4" urinal flush valve)
-WS1 (water saver) 1.0 Gal Low Consumption

Aquaflush Installation Instructions

Important:

- All Plumbing is to be installed according to state and local codes and regulations.
- Water supply lines need to allow proper water flow for each fixture.
- Flush all lines of any **debris** before making connections.
- Do not use pipe sealant or plumbing grease on any fitting other than the control stop inlet.

The Aquaflush valve is designed to operate under various water pressures with a recommended range between 10 and 100 psi (69 to 689 kPa). Each Zurn valve is tested for proper performance at the factory before being shipped. Consult the product pages of the catalog for available flow options.

Most low consumption valves (1.6 gallon) require a minimum of 25 psi running pressure through the valve to obtain proper evacuation.

When installing your quality Zurn valve, it is recommended that a smooth jawed wrench be used. This will prevent gouges and scratches on your valve.

All scored tubing connections should be assembled with loctite (see page 5)

Before starting the installation process, bore a 1-1/2" hole in wall for actuator, and a 2" hole for piping if required.

1. Install the Zurn Control Stop to the supply line with water outlet positioned as needed. If using a sweat solder adaptor, sweat the adaptor to the copper tubing before installing the control stop.

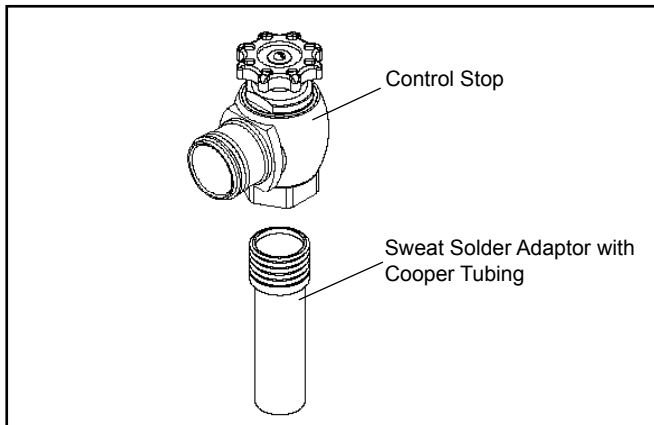

2. Attach vacuum breaker tube and elbows to fixture with spud nut. *Note: When cutting scored pipe to fit, leave a minimum of 1-1/4" of scoring to ensure proper engagement with compression coupling, and follow scored tubing loctite instruction. (See page 5)*

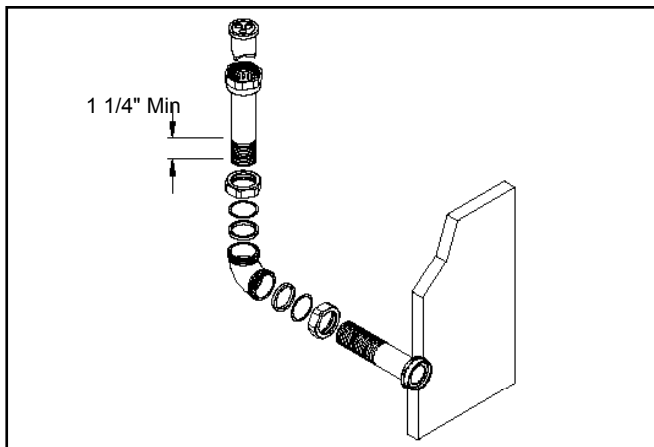

3. Remove the actuator end, coupling and mounting nut from the actuator sleeve and insert the sleeve through the 1-1/2" hole from the fixture side. Reinstall the mounting nut (hand tight), coupling and actuator end to the sleeve.
4. Insert the adjustable tail piece into the control stop while installing

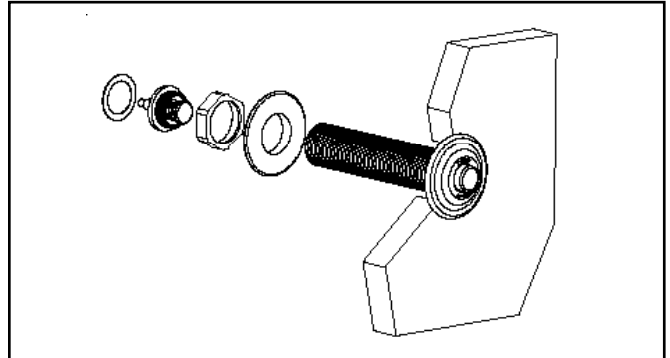

the valve. *Note: The adjustable tail piece allows for +/- 1/2" from the standard 4-3/4" centerline to centerline rough in. Lubricate O-ring on adjustable tail piece with water if needed for installation. Secure the valve by hand tightening the actuation coupling nut. After aligning the valve securely tighten the actuator assembly, control stop and the flush tube with a wrench. A smooth jaw wrench is recommended to protect special finishes.*

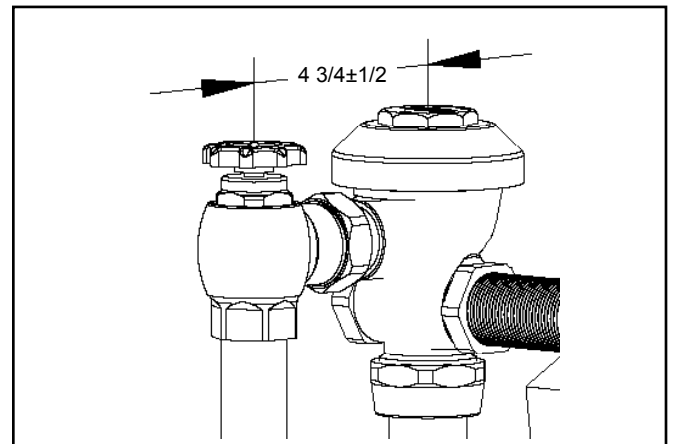

5. Shut off the control stop, remove the valve cover and remove the trip mechanism. Reinstall the valve cover and open control stop to flush lines of debris. After the lines are clear, remove the cover and reinstall the trip mechanism. Tighten the cover back on and adjust flush flow using the control stop.

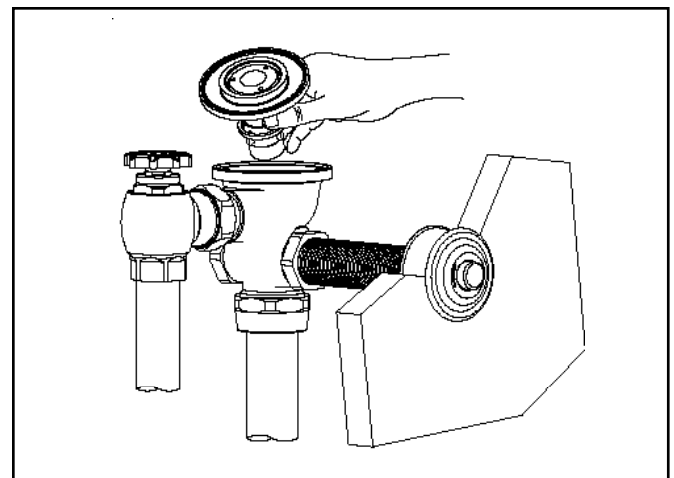

Specifying "L" Dimension for Concealed Manual-Operated Flush Valves

- Step 1: **Determine the applicable column** by locating the valve's 4-digit model number.
- Step 2: **Determine the applicable row** by locating the correct wall thickness.
NOTE: For wall thicknesses not listed, locate and use the next largest size.
- Step 3: **Order the applicable suffix** shown at the intersection of the row and column.
- Example: For closet valve model number Z6152 and a wall thickness of 6", order: Z6152-LDIM9

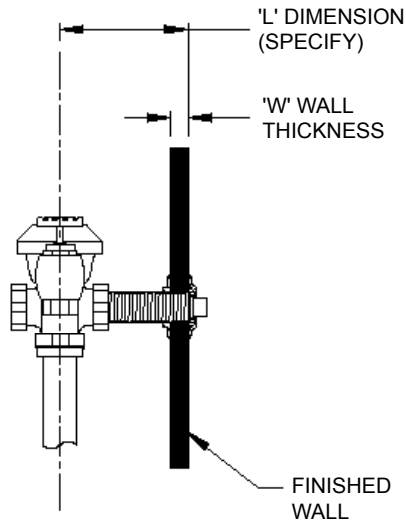

	Closets			Urinals		Combination Fixtures
Wall Thickness "W"	6140	6152	6681			
	6142	6154		6602		
	6143	6155		6609	6601	
	6144	6605		6190	6613	6603
	6150	6611		6195	6615	6616
1/4"	LDIM4	LDIM7	LDIM4	LDIM5		
1"	LDIM4	LDIM7	LDIM4	LDIM5		
2"	LDIM5	LDIM8	LDIM5	LDIM6		
3"	LDIM6	LDIM9	LDIM6	LDIM7		
4"	LDIM7	LDIM10	LDIM7	LDIM8		
5"	LDIM8	LDIM11	LDIM8	LDIM9		
6"	LDIM9	LDIM12	LDIM9	LDIM10		
7"	LDIM10	LDIM13	LDIM10	LDIM11		
8"	LDIM11	LDIM14	LDIM11	LDIM12		
9"	LDIM12	LDIM15	LDIM12	LDIM13		
10"	LDIM13	LDIM16	LDIM13	LDIM14		

Z6199 Model Access Panel and Frame for Manual-Operated Concealed Flush Valves

Z6199-BX12

Z6199-BX15

Z6199-BX17

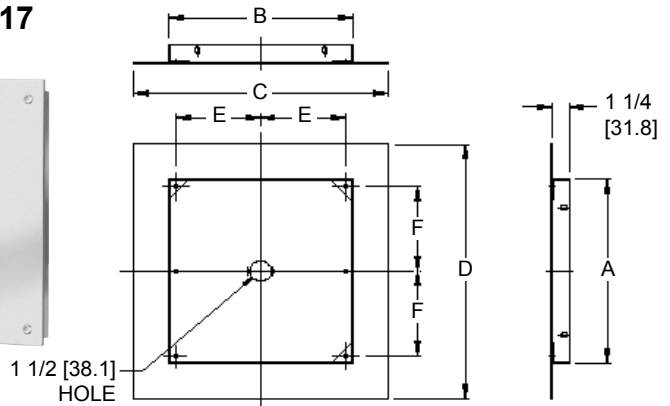
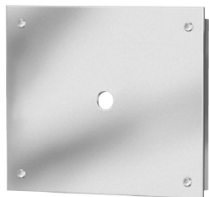

Engineering Specification: Zurn Z6199 Access Panel and Frame for Manual-Operated Concealed Flush Valves –

The access panel and frame provide quick and simple access to in-wall concealed flush valves when a mechanical chase of adequate size is not available. The panel is #14 gage stainless steel and the frame is #18 gage stainless steel. Both have a satin finish. The assembly comes complete with (4) 1" [25 mm] vandal-proof screws. Specify Z6199-BX12 for 12" x 12", Z6199-BX15 for 15" x 15", or Z6199-BX17 for 13" x 17".

Product No.	Size	A	B	C	D	E	F
Z6199-BX12	12 x 12 [305 x 305]	12 [305]	12 [305]	13-1/2 [343]	13-1/2 [343]	5-1/2 [140]	5-1/2 [140]
Z6199-BX15	15 x 15 [368 x 368]	15 [368]	15 [368]	16-1/2 [419]	16-1/2 [419]	7 [178]	7 [178]
Z6199-BX17	13 x 17 [330 x 432]	17 [432]	13 [330]	14-1/2 [368]	18-1/2 [470]	6 [152]	8 [203]

"SUFFIX OPTIONS (Check/specify appropriate options.)"	
-SP	Solid Panel
-2VPS	"2" [51mm] Long Vandal-Proof Screws"

Scored Tubing Installaion Instructions

Note: Due to the high back pressures that can be created by concealed fixtures, this procedure must be followed when installing scored flush tubes. Failure to follow these instructions can result in plumbing separation at the elbow.

For all Zurn concealed and concealed penal fixture valves with 1 1/2" flush connections.

When cutting scored vacuum breaker and horizontal connection tubes to fit, always leave at least 1 3/4" (32mm) of scoring to insure proper engagement with the compression coupling.

Install fixture flush connection. (Figure 1) Zurn penal flushometers are designed to connect to the stainless steel fixture in a chase behind the wall. A 1 1/2" pipe connection (not supplied by Zurn) must be used to connect the fixture inlet to the flanged/scored horizontal tube.

Loosely assemble the concealed plumbing after placing all of the nuts, friction washers, and gaskets in place. This will locate the gaskets prior to applying the Loctite adhesive.

Disassemble the plumbing and put a 1/8" wide bead of the adhesive around the scoring between the gasket and the end of both tubes. (Figure 2) Make sure the tubes and elbow are clean and dry before using the adhesive. DO NOT use any other pipe sealant or lubrication on these points.

Assemble the horizontal tube to the fixture and tighten securely. Slip the elbow onto the horizontal tube rotating it as pushing in to the gasket to spread the adhesive. Leave the elbow at an angle so the vacuum breaker tube can be inserted. Insert the vacuum breaker into the vacuum tube and the tube into the elbow, rotating it to spread the adhesive. Screw all nuts into place and tighten. The adhesive has a limited (2 minute) working time so tighten the connections immediately.

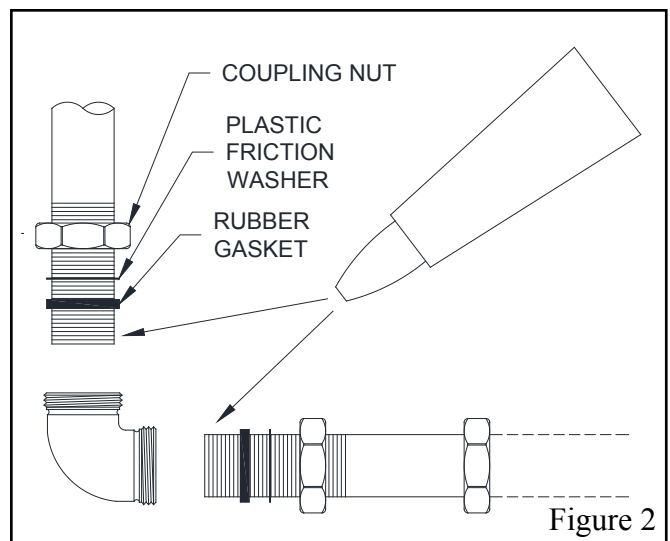
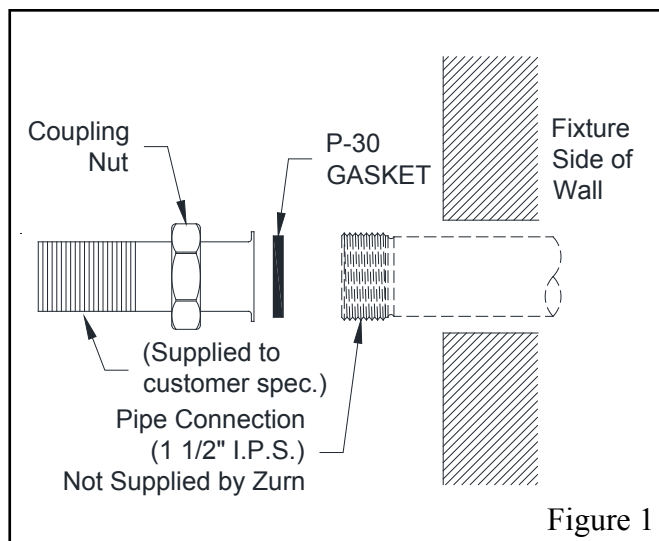

Aquaflush Trouble Shooting Guide

Problem	Cause*	Corrective Action*
Valve will not operate.	<ol style="list-style-type: none"> 1.) Stop valve is closed. 2.) Supply valve is closed. 	<ol style="list-style-type: none"> 1.) Open stop valve. 2.) Open supply valve.
Insufficient volume of water to adequately siphon fixture.	<ol style="list-style-type: none"> 1.) Stop valve is not open enough. 2.) Urinal trip mechanism installed in wrong kit, urinal or closet 3.) Insufficient volume or pressure at supply. 	<ol style="list-style-type: none"> 1.) Open stop valve for desired volume of water. 2.) Replace urinal part with proper closet valve part. 3.) If gauges are not available to measure supply pressure or volume of water at the valve, completely remove the working parts and open the stop valve to allow water to pass through the empty valve. If the supply is adequate to siphon the fixture, the guide ring (#16) may be removed from the guide assembly to provide additional flow. Should this prove unsatisfactory, steps should be taken to increase the pressure and/or supply.
Flush valve shuts off too quickly.	<ol style="list-style-type: none"> 1.) Damaged or punctured diaphragm. 2.) Enlarged by-pass orifice. 	<ol style="list-style-type: none"> 1.) Install new P6000-EUR replacement kit to remedy the problem. 2.) Install new P6000-ECR, P6000-EUR replacement kit to remedy the problem.
Valve is short flushing.	<ol style="list-style-type: none"> 1.) Cylinder guide assembly and diaphragm assembly are not tight. 2.) Enlarged by-pass orifice. 3.) Urinal trip mechanism (black #12) in closet flush valves. 	<ol style="list-style-type: none"> 1.) Screw the two assemblies hand tight. 2.) Install new P6000-ECR, P6000-EUR replacement kit to remedy the problem 3.) Install closet trip mechanism(white) .
Valve is flushing too long or not shutting off.	<ol style="list-style-type: none"> 1.) Trip mechanism not seating properly due to foreign material between trip mechanism and retainer disc. 2.) By-pass orifice is plugged or partially plugged. 3.) Line pressure is not adequate to force trip mechanism to seal. 4.) Cracked cover. 	<ol style="list-style-type: none"> 1.) Disassemble parts and rinse thoroughly. 2.) Examine by-pass orifice and clean if necessary being certain not to enlarge orifice opening. 3.) Pressure is inadequate or has dropped below minimum operating range. Steps should be taken to increase the line pressure. 4.) Replace cover with new one.
Water splashes out of fixture.	<ol style="list-style-type: none"> 1.) Supply volume is more than is necessary. 2.) Lime accumulation on vortex or spreader holes of fixture. 	<ol style="list-style-type: none"> 1.) Adjust downward on control stop. 2.) Remove the lime build up.
Flush is not considered quiet.	<ol style="list-style-type: none"> 1.) Control stop may not be adjusted for quiet operation. 2.) Fixture may be contributing to noise. 3.) Piping system may be source of noise 	<ol style="list-style-type: none"> 1.) Adjust the control stop for quiet operation keeping in mind the fixture evacuation requirements. 2.) Check noise created by fixture by placing a cover over the bowl opening to separate valve noise from bowl noise. If it is determined the fixture is too noisy consult with fixture manufacturer. 3.) High pressure in the system can sometimes be controlled by the stop valve. Other sources of noise may be the absence of air chambers and shock arrestors, loose pipes, improper size pipes, etc. In these cases the building engineer should be consulted.
Chattering noise in flush valve.	<ol style="list-style-type: none"> 1.) Segment diaphragm (#14) has been installed upside down. 2.) The inside cover has been distorted by freezing or abuse. 	<ol style="list-style-type: none"> 1.) Reposition segment diaphragm as instructed by the markings on the diaphragm ("this side down"). 2.) Replace both inside plastic cover and outside brass cover.
Handle assembly leaking.	<ol style="list-style-type: none"> 1.) Handle assembly is not tight. 	<ol style="list-style-type: none"> 1.) Tighten handle assembly.

Care of Chrome plated surfaces.

The suggested cleaning of chrome plated surfaces is simply to clean them with soap and water then dry. Commercial cleaning compounds are never recommended.

Seasonal use.

Valves used in installations subject to shut down because of cold and freezing conditions should be maintained in the following manner. After the main supply has been shut off and the water drained from the system, remove the stop valve cap and stop internals to allow the water to drain from the flush valve itself.

*see previous for numerical references.



Aquaflush Concealed Repair Kits

Parts Identification

1. Wall Escutcheon
2. Optional 1" Metal Push Button
3. Handle
4. Optional 3" Metal Push Button
5. Sleeve/Socket
6. Adjusting Nut
7. Optional Bell Nut
8. Handle Nut
9. Push Rod/Filler Rod
10. Actuator Rod
11. Handle O-Ring
12. Handle Spring
13. Handle Seal Retainer
14. Handle Seal
15. Gasket
16. Valve Body Cover
17. Plastic Cover
18. Trip Mechanism
19. Diaphragm Kit
20. Valve Body
21. Solid Gasket
22. Solid Handle Nut
23. Wheel Handle Screw
24. Wheel Handle
25. Stop Cap
26. Adjusting Screw
27. Guide Holder
28. Piston Guide
29. Guide O-Ring
30. Stop Spring
31. Piston
32. Piston Seal
33. Stop Body
34. Locking Nut
35. Tailpiece O-Ring
36. Snap Ring
37. Tailpiece
38. Vacuum Breaker Insert
39. Vacuum Breaker Duckbill
40. Vacuum Breaker Tube
41. Vacuum Breaker Tube Nut
42. Coupling Nut
43. Spud Friction Washer
44. Spud Rubber Gasket
45. 90 Degree Elbow
46. Spud Nut
47. Flanged/Scored Horizontal Tube
48. P30 Flat Gasket
49. 3/4" 90 Degree Elbow
50. 3/4" Horizontal Tube
51. 3/4" Spud Nut
52. Spud Friction Gasket
53. Spud Rubber Gasket

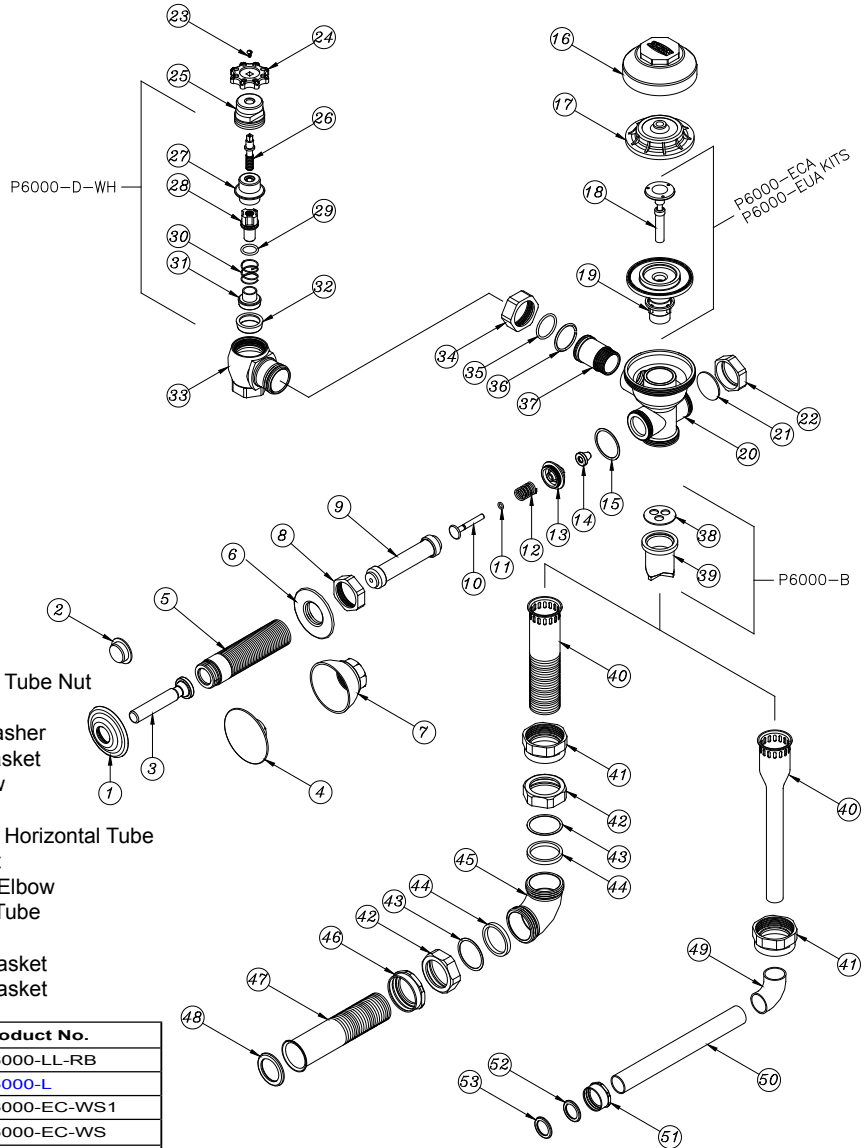

Covers and Repair Kits	Product No.
Outside Cover - RB - Item 16	P6000-LL-RB
Inside Cover - Item 17	P6000-L
Low Consumption Closet Kit - 1.6 gal. flush	P6000-EC-WS1
Water Saving Closet Kit - 3.5 gal. flush	P6000-EC-WS
Full Flow Closet Kit - 4.5 gal. flush	P6000-EC-FF
Low Consumption Urinal Kit - 1.0 gal. flush	P6000-EU-WS1
Water Saving Urinal Kit - 1.5 gal flush	P6000-EU-WS
Full Flush Urinal Kit - 3.0 gal. flush	P6000-EU-FF

Repair Parts - Inside Parts	Product No.
Urinal Relief Valve - Item 18	P6000-EU13
Closet Relief Valve - Item 18	P6000-EC13

Aquaflush Rebuild Kits	Product No.
Closet and Urinal Rebuild Kits Include Items 10-15, 18, 19, 35, 38, 39	P6000-EC-WS-RK P6000-EC-WS1-RK P6000-EU-WS-RK P6000-EU-WS1-RK

Handle Assembly and Repair Kits	Product No.
Concealed Valve Actuator (Spec. Type and 'L' Dim.)	P6000-N- P6000-NL- P6000-NL3-
Handle Repair Kit Includes Items 10-15	P6000-NK
Handle Seal Includes Item 14	P6000-M9
Handle Gasket Includes Item 15	P6000-M10

Control Stop Repair Kit and Parts	Product No.
Control Stop Repair Kit for 1" and 3/4", Includes Items 26-32	P6000-D-SD
Seal Seat for 1" and 3/4", Includes Item 26	P6000-D42
Sweat Solder Connection	P6000-YBA

Adjustable Tailpieces	Product No.
Adjustable Tailpiece for Standard Flush Valve	P6000-J1-RB
Includes Items 28-31	
Tailpiece Locking Ring Includes Item 29	P6000-C30
Tailpiece O-Ring Includes Items 30	P6000-C31
Coupling Nut Includes Item 31	P6000-C32-RB

Flush Connections and Spud Coupling Kits	Product No.
Flush Tube Assembly for Concealed Flush Valves	P6000-Q_ _
Refer to Section Q in Aqua Parts Guide	
Specify 'L' Dim. and Valve Used	
Vacuum Breaker Repair Kit Includes Items 19-21	P6000-B
Spud Coupling Assembly (Specify Size)	P6000-HN