

Model MS & XLMS Series

Integral Relief Valve Monitor Switch (3/4" thru 10")

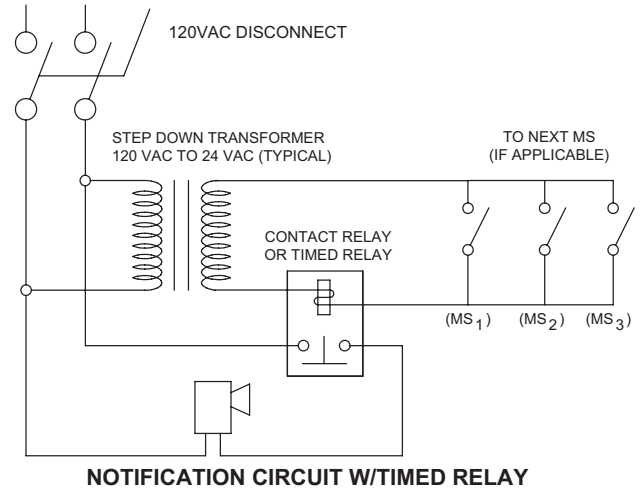

Installation Maintenance Instructions

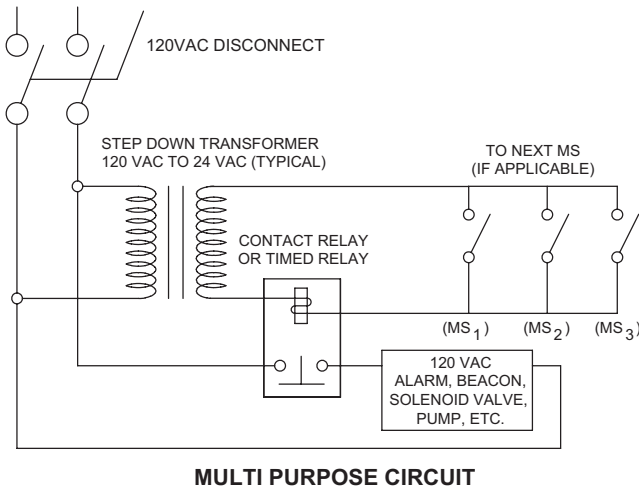

FEATURES

- Supplied with normally open contacts
- Weather resistant housing & wiring leads
- Switch contact rating: 3A @ 24VAC
- Switch is factory installed and ready for immediate installation to appropriate electric circuit

APPLICATION

The Integral Relief Valve Monitor Switch, when connected to a low voltage alarm circuit, electrically supervises the relief valve in the closed position. In the event of a backflow condition, the relief valve closes an electrical contact thereby completing an electrical circuit to signal that a possible relief valve discharge may be occurring. A timed relay can be used with a 10 second delay to prevent water hammer or inlet pressure fluctuations from causing an alarm. In addition to being used for notification, the Integral Relief Valve Monitor Switch can be use for the following:

- Pump actuation.
- Solenoid valve actuation for closure of inlet or outlet piping
- System equipment shutdown
- Initiation of system equipment when installed in point-of-use applications

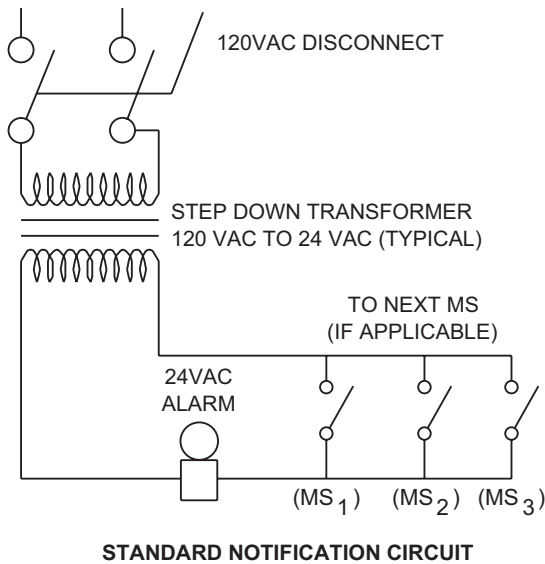

CAUTION

In all applications, the Integral Relief Valve Monitor Switch should only be used in low voltage circuits. Be certain to consult local and national electrical codes regarding fusing, grounding and proper electrical etiquette.

WARRANTY: ZURN WILKINS Valves are guaranteed against defects of material or workmanship when used for the services recommended. If in any recommended service, a defect develops due to material or workmanship, and the device is returned, freight prepaid, to ZURN WILKINS within 12 months from date of purchase, it will be repaired or replaced free of charge. ZURN WILKINS' liability shall be limited to our agreement to repair or replace the valve only.

⚠ **WARNING:** Cancer and Reproductive Harm - www.P65Warnings.ca.gov
 ⚠ **ADVERTENCIA:** Cáncer y daño reproductivo - www.P65Warnings.ca.gov
 ⚠ **AVERTISSEMENT:** Cancer et néfastes sur la reproduction - www.P65Warnings.ca.gov



ZURN WILKINS

1747 Commerce Way, Paso Robles, CA 93446 Phone:855-663-9876 Fax:805-238-5766