



AquaSense AV™

ZER Series

Automatic Sensor-Operated,
Battery-Powered Flushometer
Installation, Operation, Maintenance
and Parts Manual

Patented and Patents Pending



ZER6000AV-CP
ZER6000AV-CPM

**Sensor-Operated, Battery-Powered
Closet/Urinal Systems**

ZER6000AV-CPM
ZER6000AV-WS1-CPM
ZER6001AV-CPM
ZER6001AV-WS1-CPM
ZER6003AV-CPM
ZER6003AV-WS1-CPM



ZER6003AV-CP
ZER6003AV-CPM

⚠ WARNING: Cancer and Reproductive Harm - www.P65Warnings.ca.gov

⚠ ADVERTENCIA: Cáncer y daño reproductivo - www.P65Warnings.ca.gov

⚠ AVERTISSEMENT: Cancer et effets néfastes sur la reproduction - www.P65Warnings.ca.gov

LIMITED WARRANTY

All goods sold hereunder are warranted to be free from defects in material and factory workmanship for a period of three years from the date of purchase. Decorative finishes warranted for one year. We will replace at no costs goods that prove defective provided we are notified in writing of such defect and the goods are returned to us prepaid at Sanford, NC, with evidence that they have been properly maintained and used in accordance with instructions. We shall not be responsible for any labor charges or any loss, injury or damages whatsoever, including incidental or consequential damages. The sole and exclusive remedy shall be limited to the replacement of the defective goods. Before installation and use, the purchaser shall determine the suitability of the product for his intended use and the purchaser assumes all risk and liability whatever in connection therewith. Where permitted by law, the implied warranty of merchantability is expressly excluded. If the products sold hereunder are "consumer products," the implied warranty of merchantability is limited to a period of three years and shall be limited solely to the replacement of the defective goods. All weights stated in our catalogs and lists are approximate and are not guaranteed.

PRIOR TO INSTALLATION

Prior to installing the ZER Flushometer, install the items listed below:

- Closet or urinal fixture
- Drain line
- Water supply line

The ZER is designed to operate with 20 to 80 psi (138 to 552 kPa) of water pressure. THE MINIMUM PRESSURE REQUIRED TO THE VALVE IS DETERMINED BY THE TYPE OF FIXTURE SELECTED. Consult fixture manufacturer for pressure requirements. Protect the chrome or special finish of this flushometer. DO NOT USE TOOTHED TOOLS TO INSTALL OR SERVICE THE VALVE.

IMPORTANT:

- ALL PLUMBING IS TO BE INSTALLED IN ACCORDANCE WITH APPLICABLE CODES AND REGULATIONS.
- WATER SUPPLY LINES MUST BE SIZED TO PROVIDE AN ADEQUATE VOLUME OF WATER FOR EACH FIXTURE.
- FLUSH ALL WATER LINES PRIOR TO OPERATION (See Step 9).
- DIRT AND DEBRIS CAN CAUSE FLUSH VALVE TO RUN CONTINUOUSLY.

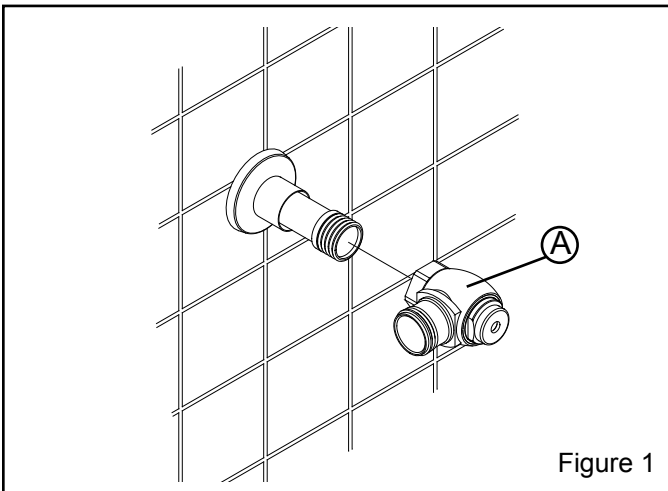

Figure 1

1.) Install stop valve assembly (A) using proper size supply escutcheon and sweat solder adapter kit if applicable. Thread sealing compounds should be used on male NPT threads only.

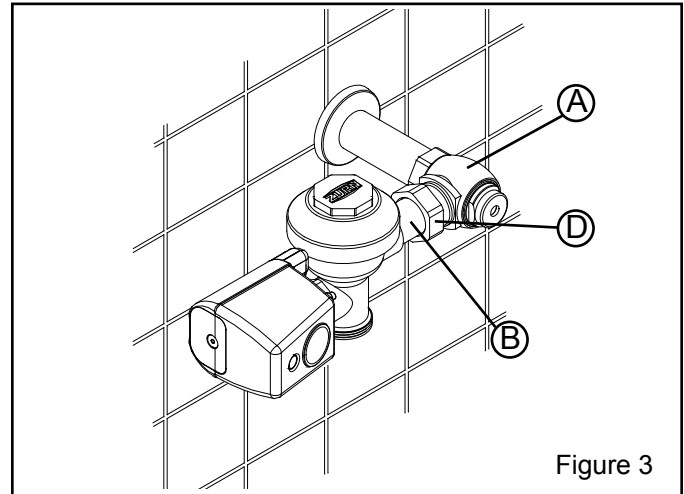

Figure 3

3.) Insert the flush valve tailpiece (B) into the stop valve (A) and hand tighten the lock nut (D) to the stop valve. Plumb the entire unit.

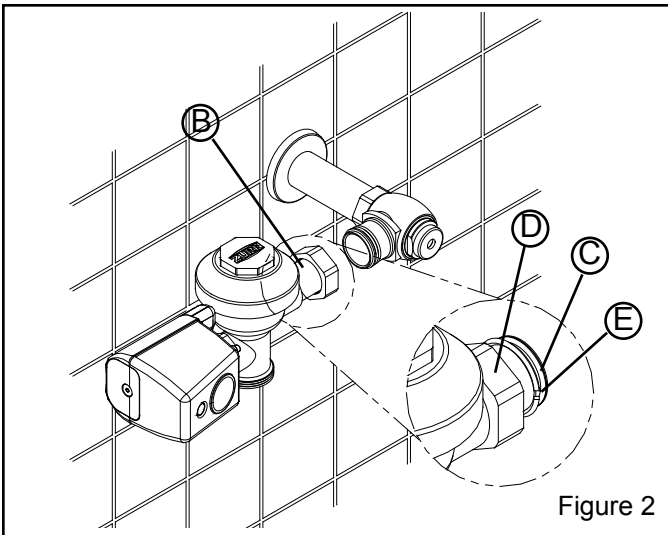

Figure 2

2.) Prior to inserting the flush valve tailpiece (B) into stop valve, be certain that the O-ring seal (C) is located in O-ring seal groove at the end of the tailpiece and the locking nut (D) and locking snap ring (E) are located as shown. Care should be taken not to damage the O-ring when inserting the tailpiece into the stop valve. If lubrication is needed, wetting the O-ring with water will be sufficient.

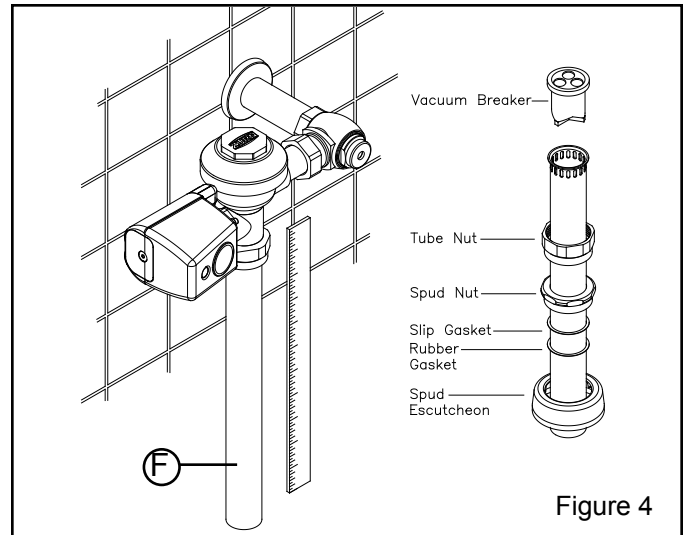

Figure 4

4.) Determine the length of vacuum breaker tube (F) required to join the flush valve and fixture spud. Cut the vacuum breaker tube, if required, to this length. Assemble the vacuum breaker tube assembly and spud nut assembly to the flush valve and fixture spud.

5.) Hand tighten spud nut and vacuum breaker tube nut to fixture and flush valve. Adjust the valve assembly for plumb. Tighten fixture spud nut, vacuum breaker tube nut and lock nut with a wrench. **Do not turn water on until batteries are inserted – see 6.**

6.) ACTIVATION

Using supplied battery compartment wrench, remove battery compartment from the E-Z Flush™ unit.

Load batteries into compartment tray (note position of batteries in tray), and reinstall battery tray into the E-Z Flush unit.

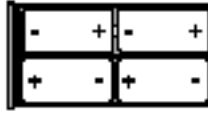

Secure tray with battery compartment wrench. The last three turns of the wrench will activate the E-Z Flush unit. The E-Z Flush System is now operational.

Your E-Z Flush unit comes preset from the factory. If special circumstances require adjustment of the activation distance, see Appendix A – Adjusting Your E-Z Flush.

The E-Z Flush unit has a 10-minute start-up sequence in which the Object Lock Sensor will flash the User-In-View **yellow L.E.D.** continuously as long as a user is in view. After the start-up sequence is completed and when the Object Lock Sensor has a user in view, the User-In-View **yellow L.E.D.** will flash only 3 times after a 5-second delay. This delay prevents needless flushes when someone walks by. Sensor units should not be located across from each other or in close proximity to highly reflective surfaces.

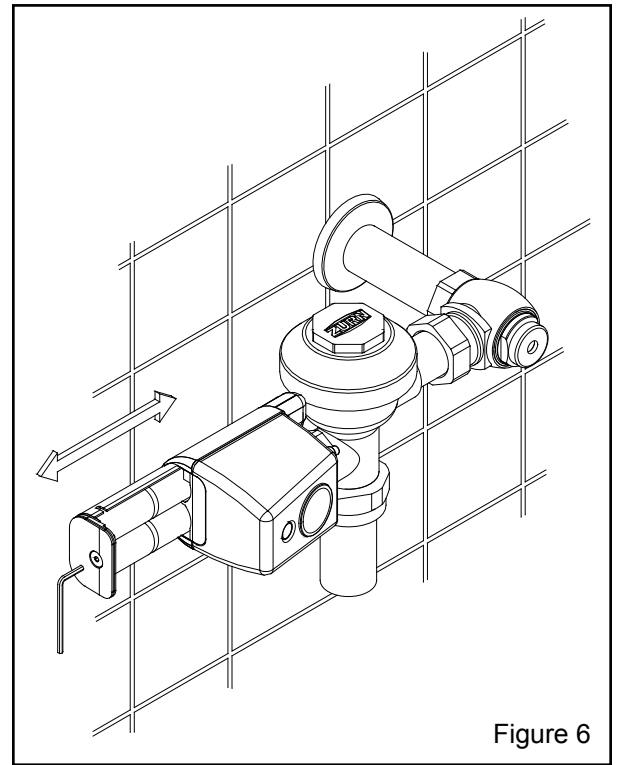

Figure 6

7.) VISUAL INDICATOR GUIDE

USER-IN-VIEW L.E.D. Yellow light flashes 3 times – after 5-second delay – when a user is in view. The yellow light flashes constantly when a user is in view during the 10-minute start-up sequence.

OBJECT LOCK SENSOR

BATTERY L.E.D. Red light flashes indicating it is time to replace batteries with 4 new “C” batteries.

COURTESY MANUAL FLUSH BUTTON Allows manual activation of flush when needed.

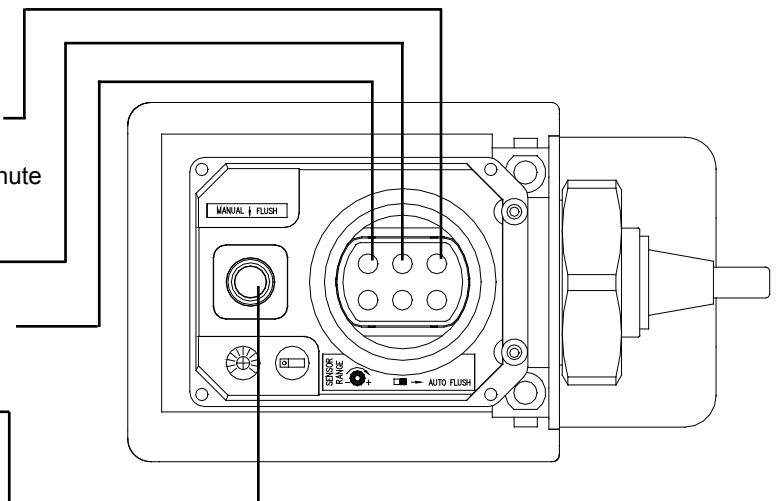

8.) ADJUSTING YOUR E-Z FLUSH

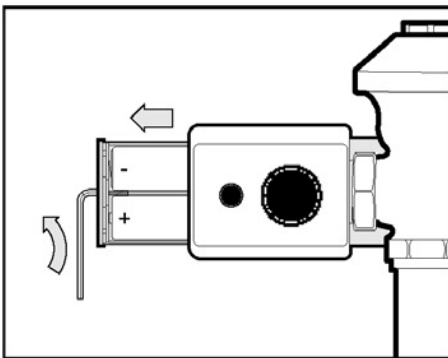

STEP A Use battery compartment wrench to remove battery compartment tray.

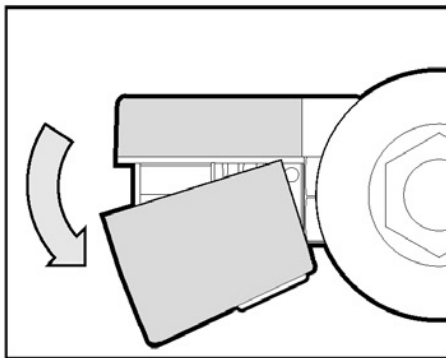

STEP B Pull cover off by rotating battery side forward and out.

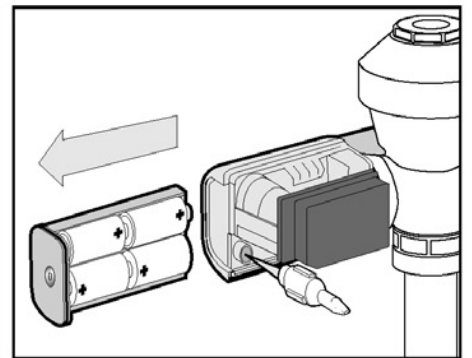

STEP C Sensor Adjustor Tool comes in a built-in storage pocket. Replace after use.

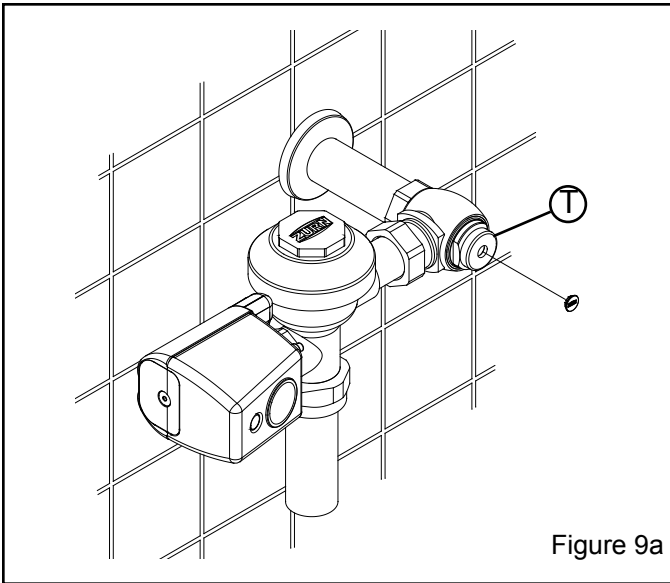

Figure 9a

Before the supply water is turned on, be sure all stop valves to the flush valves are closed off tight. The stop valves can be opened and closed by using the adjusting screw located at the center of the stop valve cap (T), behind the adjusting screw cover if already installed. Stop valve adjustments can only be made by using the adjusting screw. **It is not necessary to remove the stop valve cap when making adjustments. If for any reason it becomes necessary to remove the stop valve cap, be certain the water is shut off at the main supply valve.**

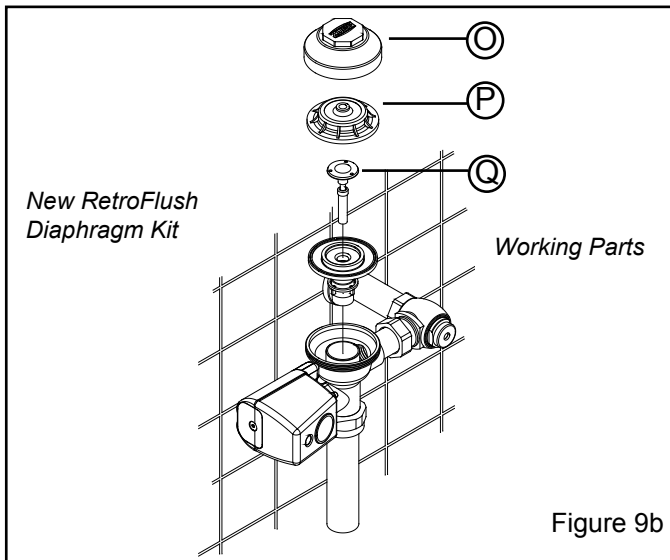

Figure 9b

9.) When all flush valves are connected to the fixtures and water pressure is available, it is recommended that the supply piping be flushed to remove dirt, pipe chips, etc., from system.

Use the following procedure to flush out the supply piping:

- A. Remove the main valve body cover (O)
- B. Remove the working parts from the flush valve (P) and (Q) (shown in 9b).
- C. Replace the plastic cover (P) and main body cover (O) without reinstalling the working parts.
- D. Open the stop valve by using the stop adjusting screw and flush out all debris from pipe and connections.
- E. Shut stop, open cover, reinstall the working parts, replace both covers and tighten.

This procedure should also be repeated when the system is drained for seasonal use, as occurs in athletic fields, recreation parks, etc.

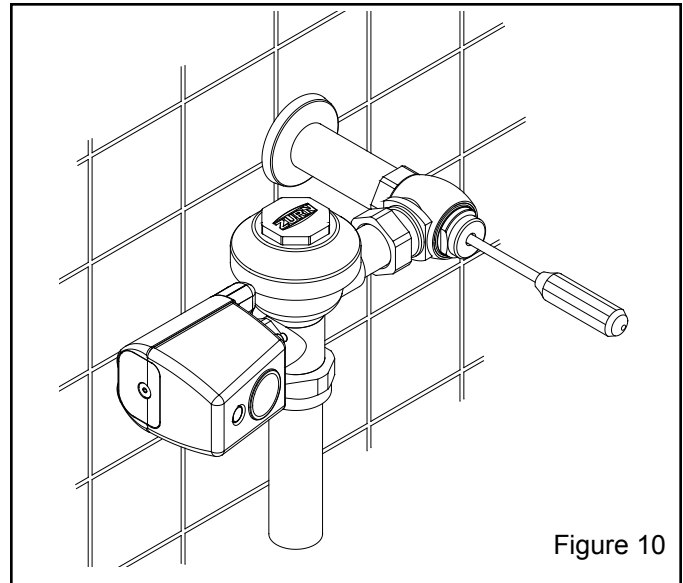

Figure 10

10.) The ZER flush valves are preset for fixture volume as marked on the valve cartons. The valve does not require regulation for variation in water pressure within its operating range. To set the flush valve for proper operation, gradually adjust the stop valve open, using the adjusting screw, while actuating the valve until the rate of water flow into the fixture is not excessive, yet is sufficient to adequately evacuate the waste. The final setting for urinals should be such that the fixture will not overflow when the valve is actuated in succession. The stop cap screw cover should be replaced after final adjustments have been made.

APPENDIX A TO CHANGE ACTIVATION DISTANCE FOR THE OBJECT LOCK SENSOR

1. Remove battery compartment tray as shown in Step 6.
2. Remove cover and sensor adjustor tool as shown in Step 6.
3. Replace battery compartment in E-Z Flush to activate unit.
4. Press sensor range reset button (the yellow L.E.D. will flash continuously when it has an object in view for the 10-minute reset period).
5. Stand at desired activation distance.
6. Use sensor adjustor tool and turn **Distance Adjustment Screw** all the way down and then turn slowly up until **yellow L.E.D.** begins to flash.
7. Ensure Object Lock Sensor is not detecting stall door or wall by closing door, stepping out of sensor path and making sure **yellow L.E.D.** is not flashing. If sensor locks onto door or wall, unit will not flush properly. Shorten activation distance.
8. Remove battery compartment, replace sensor adjustor tool and cover. Replace battery compartment tray to reactivate E-Z Flush unit.
9. After 10-minute start-up sequence, the **yellow L.E.D.** will flash only 3 times when a user is in view (after a 5-second delay).

WIRING DIAGRAM

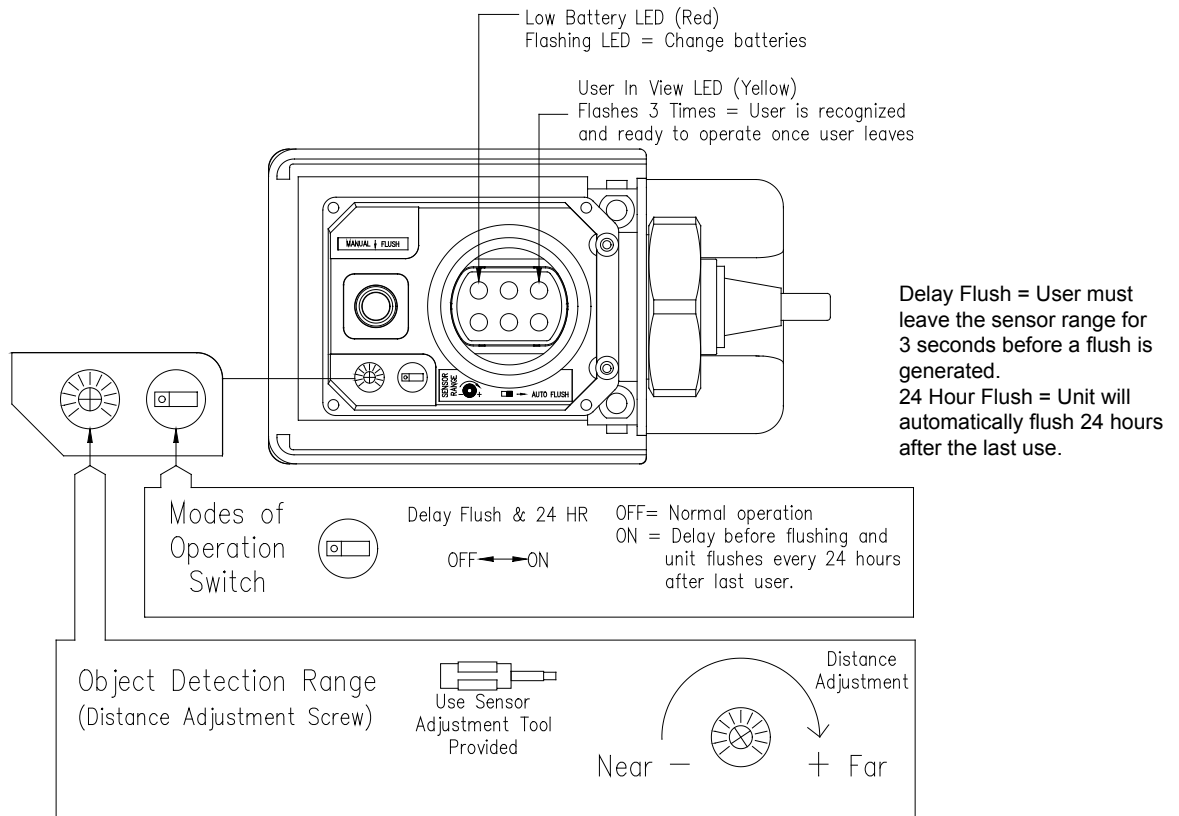

TROUBLE SHOOTING GUIDE

PROBLEM	CAUSE	SOLUTION
Yellow L.E.D. light flashes 3 times when there are no users.	Front of Object Lock Sensor is covered or Object Lock Sensor is set too far out, registering the opposite wall or door as a user.	Remove item covering sensor or adjust Object Lock Sensor activation distance. (See Appendix B – Adjusting the E-Z Flush.)
Yellow L.E.D. light flashes continuously when Object Lock Sensor is activated by a user.	E-Z Flush unit is in 10-minute start-up mode (when first activated), or Sensor Range Reset Button has been depressed.	Yellow L.E.D. light will flash only 3 times, acknowledging a user is in view after the 10-minute start-up mode.
Red L.E.D. light flashes.	Batteries need replacing.	Replace batteries.
Not enough water to fixture or too much water to fixture.	Diaphragm damaged or valve control stop improperly adjusted.	Replace diaphragm and/or adjust valve control stop.
Valve will not operate.	Object Lock Sensor range set too close to E-Z Flush, batteries are dead, or water supply is turned off.	Adjust Object Lock Sensor, replace batteries, or turn water on. If the E-Z Flush does not begin to function, call Customer Service at 1-800-997-3876.
Valve does not shut off.	Dirt or debris preventing diaphragm from functioning properly.	Remove dirt or debris, check by-pass hole in diaphragm.
Valve does not flush even after Object Lock Sensor has been adjusted.	Batteries are dead.	Replace batteries. If the E-Z Flush does not begin to function, call Customer Service at 1-800-997-3876.



AquaVantage® Exposed E-Z Flush Repair Kits

Part Identification

1. Seal
2. Collar Gasket
3. Sensor Module
4. Manual Override Push Button
5. Replacement Sensor Lens
6. Chrome Plastic Cover
7. Chrome Metal Cover
8. Battery Drawer
9. O-Ring
10. Allen Wrench
11. Handle Nut Wrench
12. Valve Body Cover
13. Plastic Cover
14. Trip Mechanism
15. Diaphragm Repair Kit
16. Valve Body
17. Vacuum Breaker Duckbill
18. Vacuum Breaker Tube
19. Vacuum Breaker Tube Nut
20. Spud Nut
21. Spud Friction Washer
22. Spud Sleeve
23. Spud Escutcheon
24. Tailpiece
25. Snap Ring
26. Tailpiece O-Ring
27. Locking Nut
28. Setscrew for Cast Wall Flange
29. Cast Wall Escutcheon
30. Supply Cover Tube
31. Sweat Solder Adapter
32. Stop Body
33. Piston Seal
34. Piston
35. Stop Spring
36. Guide O-Ring
37. Piston Guide
38. Guide Holder
39. Adjusting Screw
40. Stop Cap
41. Snap Cap Screw Cover
42. Vandal - Resistant Control Stop Cover
43. Setscrew for Control Stop Cover

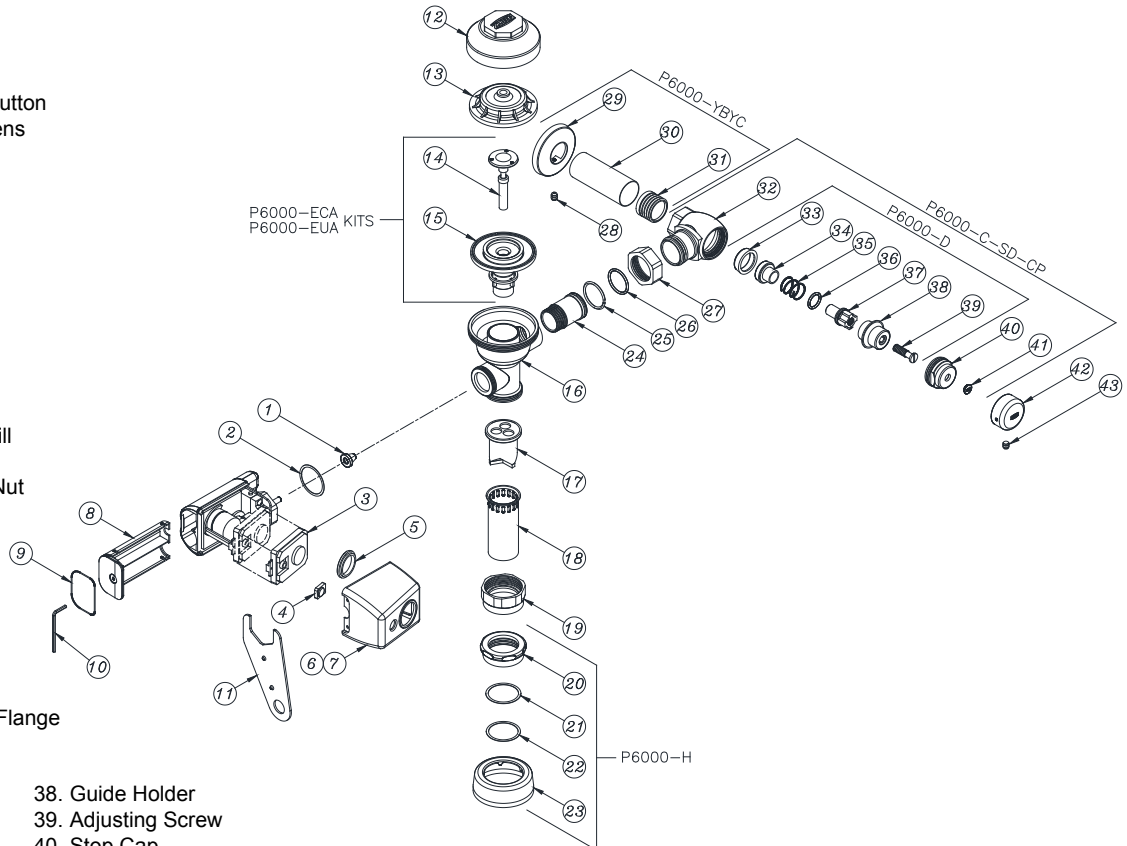

Covers and Repair Kits	Product No.
Outside Cover - CP - Item 10	P6000-LL-CP
Inside Cover - Item 11	P6000-L
Low Consumption Closet Kit - 1.28 gal. flush	P6000-ECA-HET
Low Consumption Closet Kit - 1.6 gal. flush	P6000-ECA-WS1
Water Saving Closet Kit - 3.5 gal. flush	P6000-ECA-WS
Full Flow Closet Kit - 4.5 gal. flush	P6000-ECA-FF
Ultra Low Flush Urinal Kit - 0.125 gal. flush	P6000-EUA-ULF
Extra Water Saver Urinal Kit - 0.5 gal. flush	P6000-EUA-EWS
Low Consumption Urinal Kit - 1.0 gal. flush	P6000-EUA-WS1
Water Saving Urinal Kit - 1.5 gal flush	P6000-EUA-WS
Full Flush Urinal Kit - 3.0 gal. flush	P6000-EUA-FF

Repair Parts - Inside Parts	Product No.
Urinal Relief Valve - Item 12	P6000-EU13
Closet Relief Valve - Item 12	P6000-EC13

Flush Connections and Spud Coupling Kits	Product No.
Flush Tube Assembly for Flush Valves Includes Items 15-19, Specify Diameter and Length	P6000-A
Vacuum Breaker Repair Kit, Item 17	P6000-B
Spud Coupling Assembly Includes Items 20-23 Specify Size.	P6000-H

Control Stop Repair Kit and Parts	Product No.
Control Stop Repair Kit for 1" and 3/4", Includes Items 33-39	P6000-D-SD
Seal Seat for 1" and 3/4", Includes Item 33	P6000-D42
VP Control Stop Repair Kit for 1" and 3/4", Includes Items 33-39	P6000-D-VP
Sweat Solder Connection with Cast Wall Flange, Includes Items 29-31	P6000-YBYC

Adjustable Tailpieces	Product No.
Adjustable Tailpiece for Standard Flush Valve Includes Items 24-26	P6000-J1
Tailpiece Coupling Assembly Includes Items 25-27	P6000-K
Tailpiece Locking Ring Includes Item 25	P6000-C30
Tailpiece O-Ring Includes Items 26	P6000-C31
Coupling Nut Includes Item 27	P6000-C32

Handle Assembly and Repair Kits	Product No.
Chrome Plastic Cover, Item 6	PERK6000-L-CPCR
Chrome Metal Cover, Item 7	PERK6000-L-CP-MCR
Replacement Sensor Lens Item 5	PERK6000-SCR
Battery Drawer, Item 8	PERK6000-BD
Repair Kit Includes Items 1, 2, 4, and 9	PERK6000-RK
Repair Kit Includes Items 1, 2, Retainer and Cup Seal	PERK6000-MRK
Sensor Module	PERK6000-SR

