



AquaVantage™ AV™ Z6100AV Series

AquaVantage Concealed Flushometer

Installation, Operation,
Maintenance and Parts Manual

Patented and Patents Pending



Z6140AV

**AquaVantage Concealed
Closet/Urinal Systems**

**Z6140AV
Z6142AV
Z6143AV
Z6144AV
Z6150AV
Z6152AV
Z6154AV
Z6155AV
Z6190AV
Z6195AV
Z6196AV**



Z6195AV

LIMITED WARRANTY

All goods sold hereunder are warranted to be free from defects in material and factory workmanship for a period of three years from the date of purchase. Decorative finishes warranted for one year. We will replace at no cost goods that prove defective provided we are notified in writing of such defect and the goods are returned to us prepaid at Sanford, NC, with evidence that they have been properly maintained and used in accordance with instructions. We shall not be responsible for any labor charges or any loss, injury or damages whatsoever, including incidental or consequential damages. The sole and exclusive remedy shall be limited to the replacement of the defective goods. Before installation and use, the purchaser shall determine the suitability of the product for his intended use and the purchaser assumes all risk and liability whatever in connection therewith. Where permitted by law, the implied warranty of merchantability is expressly excluded. If the products sold hereunder are "consumer products," the implied warranty of merchantability is limited to a period of three years and shall be limited solely to the replacement of the defective goods. All weights stated in our catalogs and lists are approximate and are not guaranteed.



AquaVantage™ Rough-In, Product Specification, Models and Options

ENGINEERING SPECIFICATION: ZURN AquaVantage™ 'AV' Concealed Closet Flush Valve – Concealed, quiet diaphragm-type, rough brass, flushometer valve with Zurn's AquaVantage TPE, chloramine resistant, dual seal diaphragm with a clog resistant, triple filtered by-pass. The valve is complete with a non-hold open and no leak handle feature, high back pressure vacuum breaker, one piece hex coupling nut, adjustable tailpiece, spud coupling and flange for back spud connection. Control stop has internal siphon-guard protection, and a sweat solder kit. Internal seals are made of chloramine resistant materials.

Models:

- Z6140AV- 1-1/2" Water Closet valve with top spud connection
- Z6152AV- 1-1/2" Water Closet valve with back spud connection
- Z6190AV- 1-1/4" Urinal Valve with top spud connection
- Z6195AV- 3/4" Urinal Valve with top spud connection

Flows:

- FF Full Flow
3.0 Gal. for Urinal, 4.5 Gal. for Water Closet
- WS1 Low Consumption
1.0 Gal. for Urinal, 1.6 Gal. for Water Closet
- WS Water Saver
1.5 Gal. for Urinal, 3.5 Gal. for Water Closet
(Standard Flow)

Options:

- -BG BioCare Handle
- -J Oscillating Handle
- -L 1" [25] Metal Push Button
- -L3 3" [76] Metal Push Button
- -YBA Sweat Solder Adaptor
- Other

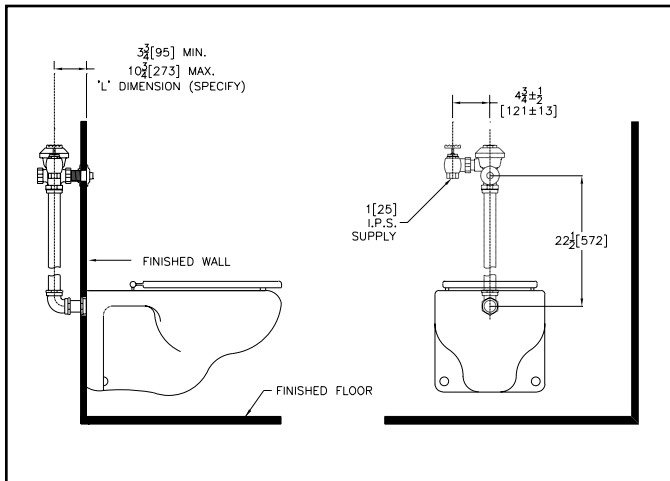

Models: Z6152AV
-WS1 (water saver) 1.6 Gal. Low Consumption

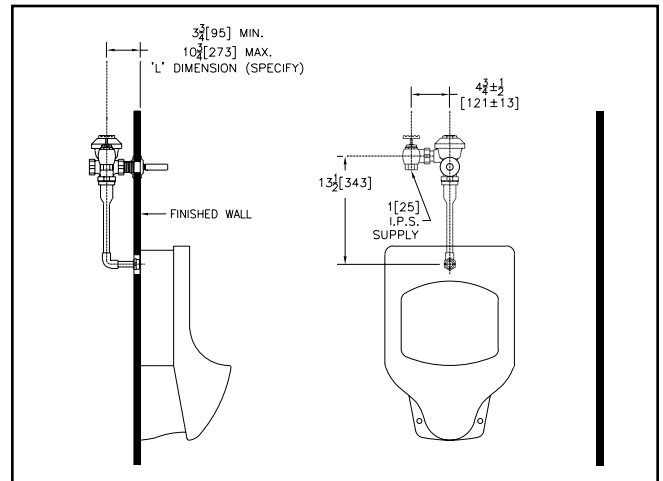

Models: Z6195AV (3/4" urinal flush valve) shown, Z6190AV (1-1/4" urinal flush valve) -WS1 (water saver) 1.0 Gal Low Consumption

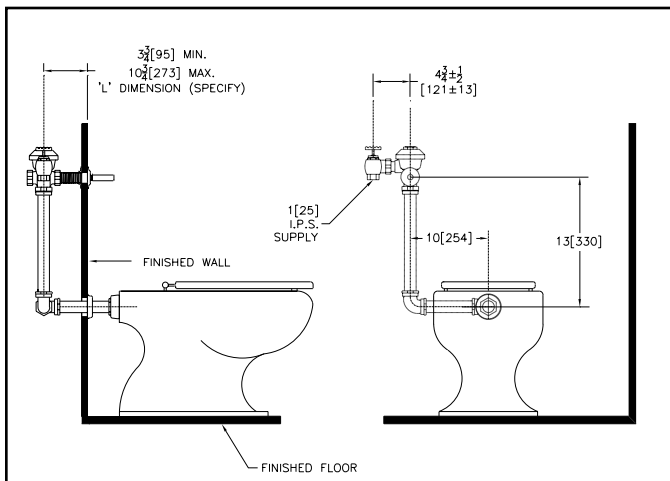

Models: Z6140AV
-WS1 (water saver) 1.6 Gal Low Consumption



AquaVantage™ Installation Instructions

Important:

- All plumbing is to be installed according to state and local codes and regulations.
- Water supply lines need to allow proper water flow for each fixture.
- Flush all lines of any **debris** before making connections.
- Do not use pipe sealant or plumbing grease on any fitting other than the control stop inlet.

The AquaVantage valve is designed to operate under various water pressures with a recommended range between 10 and 100 psi (69 to 689 kPa). Each Zurn valve is tested for proper performance at the factory before being shipped. Consult the product pages of the catalog for available flow options.

Most low consumption valves (1.6 gallon) require a minimum of 25 psi running pressure through the valve to obtain proper evacuation.

When installing your quality Zurn valve, it is recommended that a smooth jawed wrench be used. This will prevent gouges and scratches on your valve.

Before starting the installation process, bore a 1-1/2" hole in wall for actuator, and a 2" hole for piping if required.

1. Install the Zurn Control Stop to the supply line with the water outlet positioned as needed. If using a sweat solder adaptor, sweat the adaptor to copper tubing before installing control stop.

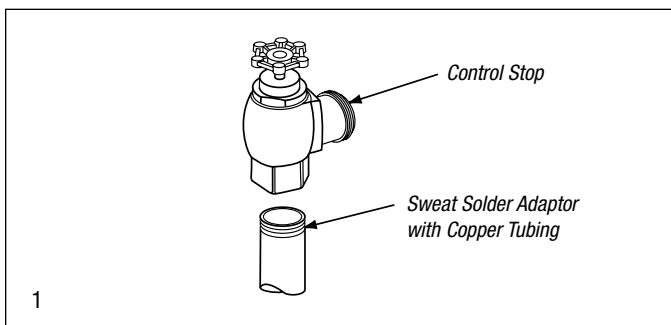

2. Attach vacuum breaker tube and elbows to fixture with spud nut. *Note: When cutting scored pipe to fit, leave a minimum of 1-1/4" of scoring to ensure proper engagement with compression coupling.*

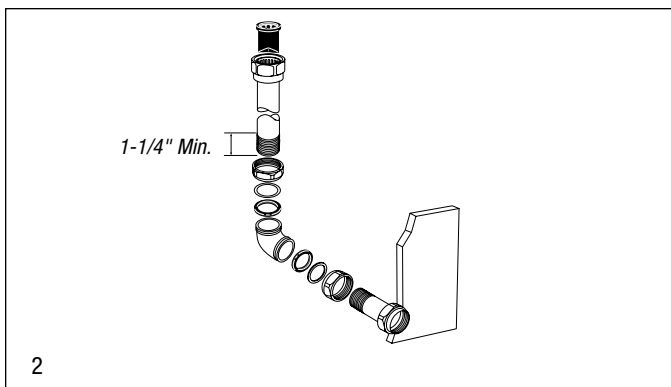

3. Remove the actuator end, coupling and mounting nut from the actuator sleeve and insert the sleeve through the 1-1/2" hole from the fixture side. Reinstall the mounting nut (hand tight), coupling and actuator end to the sleeve.

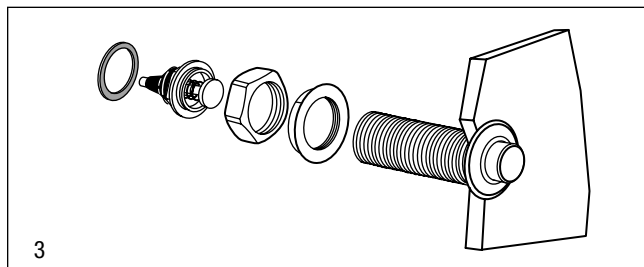

4. Insert the adjustable tail piece into the control stop while installing the valve. *Note: The adjustable tail piece allows for +/- 1/2" from the standard 4-3/4" centerline to centerline rough in.* Lubricate O-ring on adjustable tail piece with water if needed for installation. Secure the valve by hand tightening the actuation coupling nut and tail piece coupling nut. Position valve over flush tube and secure with the flush tube coupling nut. After aligning the valve securely tighten the actuator assembly, control stop and the flush tube with a wrench. *A smooth jaw wrench is recommended to protect special finishes.*

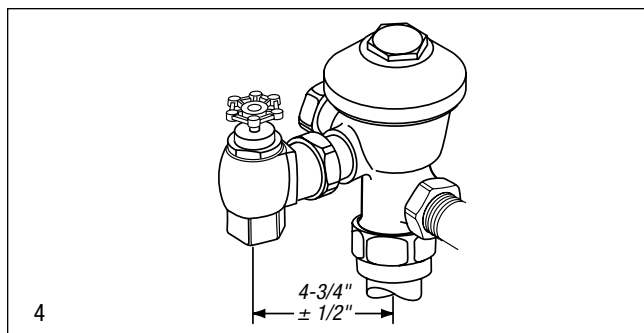

5. Shut off the control stop, remove the valve cover, internal plastic cap and remove the internal diaphragm kit. Reinstall the internal plastic cap and valve cover and open control stop to flush lines of debris. After the lines are clear, remove the cover and reinstall the internal diaphragm kit. Tighten the cover back on and adjust flush flow using the control stop. The stop cap screw cover should be replaced after final adjustments have been made.

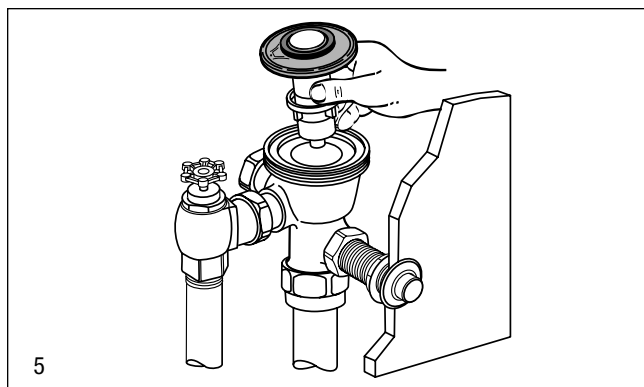



Specifying "L" Dimension for Concealed Manual-Operated Flush Valves

Step 1: **Determine the applicable column** by locating the valve's 4-digit model number.

Step 2: **Determine the applicable row** by locating the correct wall thickness.
NOTE: For wall thicknesses not listed, locate and use the next largest size.

Step 3: **Order the applicable suffix** shown at the intersection of the row and column.

Example: For closet valve model number Z6152AV and a wall thickness of 6", order: Z6152AV-LDIM9.

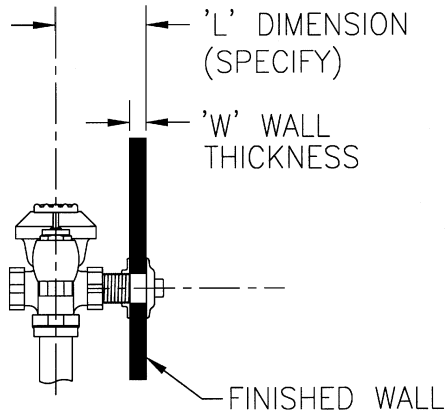

Wall Thickness "W"	Closets		Urinals		Combination Fixtures
	6140AV 6142AV 6143AV 6144AV 6150AV	6152AV 6154AV 6155AV 6605AV 6611AV	6681AV	6190AV 6195AV	6602AV 6609AV 6613AV 6615AV
1/4"	LDIM4	LDIM7	LDIM4	LDIM5	LDIM5
1"	LDIM4	LDIM7	LDIM4	LDIM5	LDIM5
2"	LDIM5	LDIM8	LDIM5	LDIM6	LDIM6
3"	LDIM6	LDIM9	LDIM6	LDIM7	LDIM7
4"	LDIM7	LDIM10	LDIM7	LDIM8	LDIM8
5"	LDIM8	LDIM11	LDIM8	LDIM9	LDIM9
6"	LDIM9	LDIM12	LDIM9	LDIM10	LDIM10
7"	LDIM10	LDIM13	LDIM10	LDIM11	LDIM11
8"	LDIM11	LDIM14	LDIM11	LDIM12	LDIM12
9"	LDIM12	LDIM15	LDIM12	LDIM13	LDIM13
10"	LDIM13	LDIM16	LDIM13	LDIM14	LDIM14

Z6199 Model Access Panel and Frame for Manual-Operated Concealed Flush Valves

Z6199-BX12

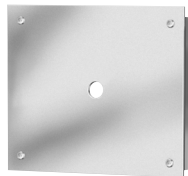

Z6199-BX15

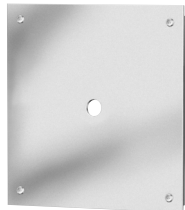

Z6199-BX17

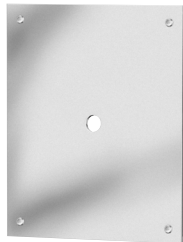

Z6199

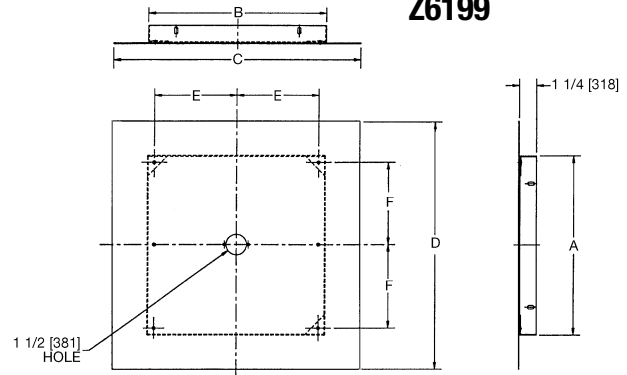

Engineering Specification: Zurn Z6199 Access Panel and Frame for Manual-Operated Concealed Flush Valves

– The access panel and frame provide quick and simple access to in-wall concealed flush valves when a mechanical chase of adequate size is not available. The panel is #14 gage stainless steel and the frame is #18 gage stainless steel. Both have a satin finish. The assembly comes complete with (4) 1" [25mm] vandal-proof screws. Specify Z6199-BX12 for 12" x 12", Z6199-BX15 for 15" x 15", or Z6199-BX17 for 13" x 17".

Product No.	Size	A	B	C	D	E	F
Z6199-BX12	12x12 [305x305]	12 [305]	12 [305]	13-1/2 [343]	13-1/2 [343]	5-1/2 [140]	5-1/2 [140]
Z6199-BX15	15x15 [368x368]	15 [368]	15 [368]	16-1/2 [419]	16-1/2 [419]	7 [178]	7 [178]
Z6199-BX17	13x17 [330x432]	17 [432]	13 [330]	14-1/2 [368]	18-1/2 [470]	6 [152]	8 [203]

SUFFIX OPTIONS

(Check/specify appropriate options.)

-SP Solid Panel

-2VPS 2" [51mm] Long
Vandal-Proof Screws



AquaVantage™ Repair Kits

Parts Identification

1. Optional 1" Metal Push Button
2. Optional 3" Metal Push Button
3. Handle
4. Actuator Rod
5. Handle O-Ring
6. Handle Spring
7. Handle Seal Retainer
8. Handle Seal
9. Gasket
10. Valve Body Cover
11. Plastic Cover
12. Trip Mechanism
13. Diaphragm Repair Kit
14. Valve Body
15. Vacuum Breaker Friction Washer
16. Vacuum Breaker Insert
17. Vacuum Breaker Duckbill
18. Vacuum Breaker Tube
19. Vacuum Breaker Tube Nut
20. Coupling Nut
21. Spud Friction Washer
22. Spud Rubber Gasket
23. 90° Elbow
24. Tailpiece
25. Snap Ring
26. Tailpiece O-Ring
27. Locking Nut
32. Stop Body
33. Piston Seal
34. Piston
35. Stop Spring
36. Guide O-Ring
37. Piston Guide
38. Guide Holder
39. Adjusting Screw
40. Stop Cap
41. Wheel Handle
42. Wheel Handle Screw
43. Solid Gasket
44. Solid Handle Nut
45. Flanged/Scored Horizontal Tube
46. P30 Flat Gasket
47. Wall Escutcheon
258. Sleeve/Socket
249. Adjusting Nut
250. Optional Bell Nut
251. Handle Nut
252. Push Rod/Filler Rod
253. Spud Nut
254. 3/4" 90° Elbow
255. 3/4" Horizontal Tube
256. 3/4" Spud Nut
257. Spud Friction Washer
258. Spud Rubber Gasket

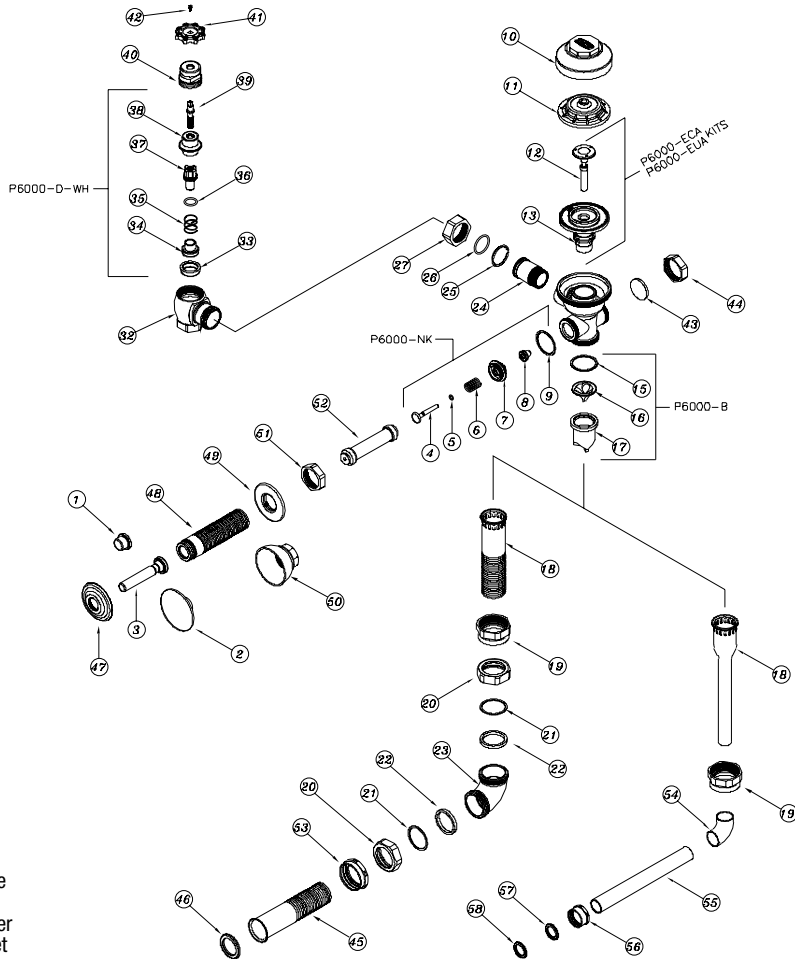

Covers and Repair Kits	Product No.
Outside Cover - RB - Item 10	P6000-LL-RB
Inside Cover - Item 11	P6000-L
Low Consumption Closet Kit - 1.6 gal. flush	P6000-ECA-WS1
Water Saving Closet Kit - 3.5 gal. flush	P6000-ECA-WS
Full Flow Closet Kit - 4.5 gal. flush	P6000-ECA-FF
Low Consumption Urinal Kit - 1.0 gal. flush	P6000-EUA-WS1
Water Saving Urinal Kit - 1.5 gal. flush	P6000-EUA-WS
Full Flush Urinal Kit - 3.0 gal. flush	P6000-EUA-FF

Repair Parts - Inside Parts	Product No.
Urinal Relief Valve - Item 12	P6000-EU13
Closet Relief Valve - Item 12	P6000-EC13

Aquaflush Rebuild Kits	Product No.
Closet and Urinal Rebuild Kits Include Items 4-9, 12, 13, 15-17, 26	P6000-ECA-WS-RK
	P6000-ECA-WS1-RK
	P6000-EUA-WS-RK
	P6000-EUA-WS1-RK

Handle Assembly and Repair Kits	Product No.
Concealed Valve Actuator (Spec. Type and 'L' Dim.)	P6000-N-
	P6000-NL-
	P6000-NL3-
Handle Repair Kit (Side) Includes Items 4-9	P6000-NK
Handle Seal Includes Item 8	P6000-M9
Handle Gasket Includes Item 9	P6000-M10

Control Stop Repair Kit and Parts	Product No.
Control Stop Repair Kit for 1" and 3/4", Includes Items 33-39	P6000-D-SD
Seal Seat for 1" and 3/4", Includes Item 33	P6000-D42
Sweat Solder Connection	P6000-YBA

Adjustable Tailpieces	Product No.
Adjustable Tailpiece for Standard Flush Valve Includes Items 24-26	P6000-J1-RB
Tailpiece Locking Ring Includes Item 25	P6000-C30
Tailpiece O-Ring Includes Item 26	P6000-C31
Coupling Nut Includes Item 27	P6000-C32-RB

Flush Connections and Spud Coupling Kits	Product No.
Flush Tube Assembly for Concealed Flush Valves Refer to Section Q in AquaParts Guide. Specify 'L' Dim. and valve used.	P6000-Q _ _ -
Vacuum Breaker Repair Kit Includes Items 15-17	P6000-B
Spud Coupling Assembly Includes Items 56-58 Specify size.	P6000-HN



AquaVantage™ Trouble Shooting Guide

Problem	Cause*	Corrective Action*
Valve will not operate.	<ol style="list-style-type: none"> 1.) Stop valve is closed. 2.) Supply valve is closed. 	<ol style="list-style-type: none"> 1.) Open stop valve. 2.) Open supply valve.
Insufficient volume of water to adequately siphon fixture.	<ol style="list-style-type: none"> 1.) Stop valve is not open enough. 2.) Urinal trip mechanism installed in wrong kit, urinal or closet. 3.) Insufficient volume or pressure at supply. 	<ol style="list-style-type: none"> 1.) Open stop valve for desired volume of water. 2.) Replace urinal part with proper closet valve part. 3.) If gauges are not available to measure supply pressure or volume of water at the valve, completely remove the working parts and open the stop valve to allow water to pass through the empty valve. If the supply is adequate to siphon the fixture, the guide ring may be removed from the guide assembly to provide additional flow. Should this prove unsatisfactory, steps should be taken to increase the pressure and/or supply.
Flush valve shuts off too quickly.	<ol style="list-style-type: none"> 1.) Damaged or punctured diaphragm. 	<ol style="list-style-type: none"> 1.) Install new P6000-EUA replacement kit to remedy the problem. (#12 thru #13)
Valve is short flushing.	<ol style="list-style-type: none"> 1.) Cylinder guide assembly and diaphragm assembly are not tight. 2.) Urinal trip mechanism (black #12) in closet flush valves. 	<ol style="list-style-type: none"> 1.) Screw the two assemblies hand tight. 2.) Install closet trip mechanism (white #12).
Valve is flushing too long or not shutting off.	<ol style="list-style-type: none"> 1.) Trip mechanism not seating properly due to foreign material between trip mechanism and retainer disc. 2.) By-pass orifice is plugged or partially plugged. 3.) Line pressure is not adequate to force trip mechanism to seal. 4.) Cracked cover. 	<ol style="list-style-type: none"> 1.) Disassemble parts and rinse thoroughly. 2.) Examine by-pass orifice and clean if necessary being certain not to enlarge orifice opening. 3.) Pressure is inadequate or has dropped below minimum operating range. Steps should be taken to increase the line pressure. 4.) Replace cover with new one (#11).
Water splashes out of fixture.	<ol style="list-style-type: none"> 1.) Supply volume is more than is necessary. 2.) Lime accumulation on vortex or spreader holes of fixture. 	<ol style="list-style-type: none"> 1.) Adjust downward on control stop. 2.) Remove the lime build up.
Flush is not considered quiet.	<ol style="list-style-type: none"> 1.) Control stop may not be adjusted for quiet operation. 2.) Fixture may be contributing to noise. 3.) Piping system may be source of noise. 	<ol style="list-style-type: none"> 1.) Adjust the control stop for quiet operation keeping in mind the fixture evacuation requirements. 2.) Check noise created by fixture by placing a cover over the bowl opening to separate valve noise from bowl noise. If it is determined the fixture is too noisy consult with fixture manufacturer. 3.) High pressure in the system can sometimes be controlled by the stop valve. Other sources of noise may be the absence of air chambers and shock arrestors, loose pipes, improper size pipes, etc. In these cases the building engineer should be consulted.
Chattering noise in flush valve.	<ol style="list-style-type: none"> 1.) The inside cover has been distorted by freezing or abuse. 	<ol style="list-style-type: none"> 1.) Replace both inside plastic cover and outside brass cover.
Handle assembly leaking.	<ol style="list-style-type: none"> 1.) Handle assembly is not tight. 	<ol style="list-style-type: none"> 1.) Tighten handle assembly.

Care of Chrome Plated Surfaces

The suggested cleaning of chrome plated surfaces is simply to clean them with mild soap and water, then dry. Commercial cleaning compounds are never recommended.

Seasonal Use

Valves used in installations subject to shut down because of cold and freezing conditions should be maintained in the following manner. After the main supply has been shut off and the water drained from the system, remove the stop valve cap and stop valve internals to allow the water to drain from the flush valve itself.

*See previous page for numerical references.

ZURN PLUMBING PRODUCTS GROUP COMMERCIAL BRASS OPERATION

5900 ELWIN BUCHANAN DRIVE, SANFORD, NC, U.S.A. 27330, PHONE: 1-800-997-3876, FAX: 919/775-3541, WEBSITE: www.zurn.com

IN CANADA: **ZURN INDUSTRIES LIMITED** 3544 NASHUA DRIVE, MISSISSAUGA, ONTARIO L4V 1L2, PHONE: 905/405-8272, FAX: 905/405-1292