

OWNER'S , SERVICE & INSTRUCTION  
M A N U A L

**ZESTO**

ELECTRIC CONVEYOR OVENS

<b>MODEL</b>	CE 2416 / 2418	X
	CE 3018 / 3018HD	X
	CE 4018	X
	CE 3624 / 3632	X
	CE 4824 / 4832	X
	CE 6024 / 6032	X

IMPORTANT INSTRUCTIONS FOR  
OVEN INSTALLATION, OPERATION AND  
MAINTENANCE

**ZESTO**

FOOD EQUIPMENT MANUFACTURING INC.

MANUFACTURIER D'EQUIPEMENT EN ALIMENTATION INC.

6450 HUTCHISON, MONTREAL, QUEBEC, H2V 4C8 TEL(514)278-4621 FAX(514)278-4622

e-mail: info@zesto.ca

www.zesto.ca

**NOTICE**

A permanently connected appliance provided with casters or wheels on all legs of the appliance shall be provided with a means for securing the appliance to the building structure to limit the movement of the appliance so that stress is not transmitted to the electrical supply conduit complying with either UL 197 or ISBN 0-7629-0856-4

**IMPORTANT FOR YOUR SAFETY**

Improper installation, adjustment, service or maintenance can cause property damage, injury or death. Read the installation, operating and maintenance instructions thoroughly before installing this equipment.

**FOR YOUR SAFETY**

Do not store or use gasoline or flammable vapors or liquids in the vicinity of this or any other appliance.

**CAUTION**

Risk of electric shock. Do Not Obstruct Access to this Panelboard. No Storage in this Area

**CAUTION**

Electical disconnect breaker should be installed on each oven section with a minimum 3mm spaced contact. Disconnect the power supply before any repairs or maintainance work is perfomed on oven.

**IN THE EVENT OF A POWER FAILURE DO NOT ATTEMPT TO OPERATE THIS DEVICE. SHUT OFF POWER.**

# TABLE OF CONTENTS

<b>GENERAL .....</b>	<b>4</b>
Purchaser's Responsibility .....	4
<b>INSTALLATION.....</b>	<b>4</b>
Ventilation .....	4
Receiving .....	5
Location .....	5
Installation Codes and Standards .....	5
Stacking Ovens .....	5
Installing Basic Oven .....	5 - 6
<b>OPERATION .....</b>	<b>7 - 8</b>
Temperature Control .....	7
Speed Control .....	8
<b>MAINTENANCE .....</b>	<b>9 - 11</b>
Cleaning .....	9 - 10
Belt removal for cleaning .....	11
<b>ADJUSTMENTS - AIR &amp; THERMOCOUPLE .....</b>	<b>12 - 15</b>
Adjustment of Air Distribution .....	12 - 15
Thermocouple .....	15
<b>TECHNICAL SERVICE .....</b>	<b>16 - 20</b>
Electrical heating system.....	16 - 17
Gear Motor .....	18
Heat Circulating Blower Motor .....	19
Cooling Fan (Axial) .....	20
<b>WIRING DIAGRAMS .....</b>	<b>21a - 21b</b>
<b>TROUBLESHOOTING .....</b>	<b>22</b>
<b>COOKING CHART .....</b>	<b>23</b>
<b>WARRANTY .....</b>	<b>24</b>

**SAVE THESE INSTRUCTIONS FOR FUTURE USE**

**GENERAL:** Read these instructions and keep them for future reference. Before installing the oven, consult your local building authority and obtain a building permit if necessary. Do not modify or alter the construction of the oven or any of its components. Install the oven as described in these instructions. Use only **ZESTO** components. Failure to do so will void the Certification approvals and the warranty of this oven.

**PURCHASER'S RESPONSIBILITY**

1. To see that the electric services for the oven are installed on site in accordance with the manufacturer's specifications.
2. To unload, uncrate and install the oven in its proper location in accordance with the Installation Operation Manual.
3. To see that the electric services are connected properly by a qualified licensed **ELECTRICIEN** or installer of your choice. All such connections must be in accordance with applicable Code requirements.
4. **Do not** attempt to operate the oven until connection of utility service has been fully inspected by an authorized service technician.

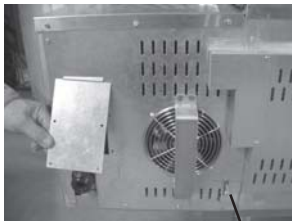
**INSTALLATION WARNING:**

**Input voltage and phasing must match the units voltage & phasing.**

**Remove back panel and pass the service line through the rear of the unit and connect to the terminal block.**

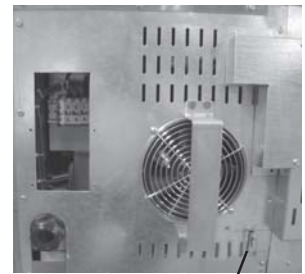

**WARNING: ADEQUATE MEANS MUST BE PROVIDED TO LIMIT THE MOVEMENT OF CASTERED APPLIANCES. A RESTRAINING DEVICE IS REQUIRED FOR ALL TYPES OF MOVEABLE APPLIANCES.**

**WARNING:**

- \* **INSTALLATION AND REPAIR SHOULD BE DONE BY A QUALIFIED SERVICE PERSON. THE APPLIANCE SHOULD BE INSPECTED BEFORE USE AND AT LEAST ANNUALLY BY A QUALIFIED SERVICE TECHNICIAN. MORE FREQUENT CLEANING MAY BE REQUIRED DUE TO OVEN GREASE VAPORS, DUST, ETC. IT IS IMPERATIVE THAT CONTROL COMPARTMENTS, BURNERS AND CIRCULATING AIR PASSAGEWAYS OF THE OVEN BE KEPT CLEAN.**
- \* **DO NOT MODIFY THIS APPLIANCE.**
- \* **DO NOT BLOCK THE AIR REGISTERS ON THE OVEN AS THIS WILL CAUSE THE OVEN TO OVERHEAT.**

**WARNING: DO NOT USE THIS APPLIANCE IF ITS CONTROL HAS BEEN UNDER WATER. IMMEDIATELY CALL A QUALIFIED SERVICE TECHNICIAN TO INSPECT THE APPLIANCE AND TO REPLACE ANY PART OF THE CONTROL SYSTEM WHICH HAS BEEN UNDER WATER.**

**VENTILATION:**

1. Ventilation hood should extend 6" (15cm) minimum past the oven on the front and back and 6" (15cm) minimum past each side of the conveyor belt and hung 6'6" (198cm) above the floor surface.
2. Exhaust - Approximately 2000 CFM required for double stacked ovens.  
Approximately 1500 CFM required for single oven.  
Make-up air should be 65% - 80% of the exhaust air rating.

**RECEIVING:**

Immediately after receiving the oven, check for possible shipping damages. If this oven is found to be damaged, save the packaging material and contact the carrier within 15 days of delivery. Prior to installation, verify that the electrical service and type of gas (natural or propane) agree with the specifications on the oven data plate, located on right front side service panel. Do not use the door or the handle to lift oven.

**LOCATION:**

Verify that the doors and access routes into kitchen area are checked for clearance. (When crate is turned on its side, the oven will pass through a 864mm [34"] door opening). The equipment area must be kept free and clear of combustibles. Maintain clearances from combustible or noncombustible construction of at least 76mm (3") from the side and 76mm (3") from the back of the oven. The installation location must allow adequate clearances for servicing and proper operation.

**INSTALLATION CODES AND STANDARDS:**

This oven complies with the National Standards of Canada and the United States and is certified by the Warnock Hersey Inchcape Services and ETL under the standards of UL 197 (ANSI / UL STD.) and National Sanitation Foundation (NSF). In Canada the installation must conform with local codes or, in the absence of local codes, with the current CAN/CGA B149 Installation Code.

The oven, when installed, must be electrically grounded in accordance with the local codes or, in the absence of local codes, with the current Canadian Electrical Code: CSA C22.2 Number 109. In the United States, installations must conform with local codes, with the current UL 197 (ANSI / UL STD.).

The oven, when installed, must be electrically grounded in accordance with local codes or, in the absence of local codes, with the American National Electrical Code; ANSI/NFPA 70 (latest edition).

**A separate electrical switch box must be provided for each oven. For stacked ovens, each oven must be considered as a separate oven.**

**INSTALLING BASIC OVEN:**

- 1) Tilt oven on back side
- 2) Place oven on 4 wheel dolly
- 3) Direct oven to location
- 4) Remove oven from dolly and place on 2 pieces of 4" (100mm) x 4" (100mm) wood
- 5) Undo crate
- 6) Fasten front legs to oven
- 7) Tilt oven forward resting on front legs
- 8) Lift oven from rear
- 9) Once oven is lifted fasten back legs to oven
- 10) Oven is now ready to be placed in operating location

**STACKING OVENS:**

Follow same procedure as above to uncrate and then lift and place oven on top of bottom one.

No fasteners are required, the weight of the oven will keep it in place.

**MODELLE CG/CE 3018, 3018HD, 4018**

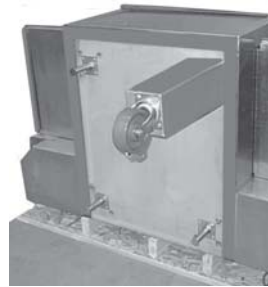
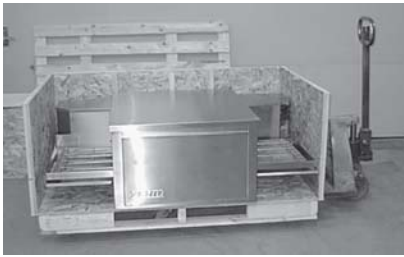

**MODELLE CG/CE 3624, 3632, 4824, 4832, 6024, 6032**



1)



2)



3)



4)



5)



6)



7)



8)



9)



10)

## TEMPERATURE CONTROLLER:

REF #0907-53

**NOTE: \* DON'T TOUCH THESE ADJUSTMENTS, IT'S ALREADY CALIBRATED**

**#VD 2001 / 2601 INITIAL POWER-UP:** (Part #ZDIVD2001TRIDNA) When power is applied to the control it will begin operating using the factory set point. The process temperature as measured by the thermocouple will appear in the digital display and the **LOAD (PV)** will indicate if the control output (load) is on.

**Key pad:**

 - Parameter display / set-point programming.











































 - Press to Raise Temperature of Oven.

 - Press to Lower Temperature of Oven.



**⚠ WARNING:**

**To program Controller follow the following steps:(adjustments to be done only by qualified technician)**

- 1) Press and hold  for 5 seconds till *Pb* appears, then keep pressing toggling  till *LoCt* appears. Press  till you find 0 100 this unlocks the program.
- 2) Press  till *Pb* appears press  or  till you find 0.0.
- 3) Press  till *HYS* appears press  or  till you find 2.
- 4) Press  till *R IHY* appears press  or  till you find 0.
- 5) Press and hold  for 5 seconds till *Pb* appears, then keep pressing toggling  till *TYPE* appears press  or  till you find *E* (K thermocouple)
- 6) Press  till *Unit* appears press  or  till you find *F*<sup>0</sup> or *C*<sup>0</sup>
- 7) Press  till *dP* appears press  or  till you find 0000.
- 8) Press  till *Act* appears press  or  till you find *rE*
- 9) Press  till *LoL* appears press  or  till you find 0.
- 10) Press  till *H iL* appears press  or  till you find 625F<sup>0</sup> or 330C<sup>0</sup>.
- 11) Press  till *F iL* appears press  or  till you find 5.0.
- 12) Press  and  holding both to exit program.
- 13) Press and hold  for 5 seconds till *Pb* appears, then keep pressing toggling  till *LoCt* appears. Press  or  till you find 0 001 this locks the program.
- 14) Press  and  holding both to exit program.

### WIRING CONNECTION

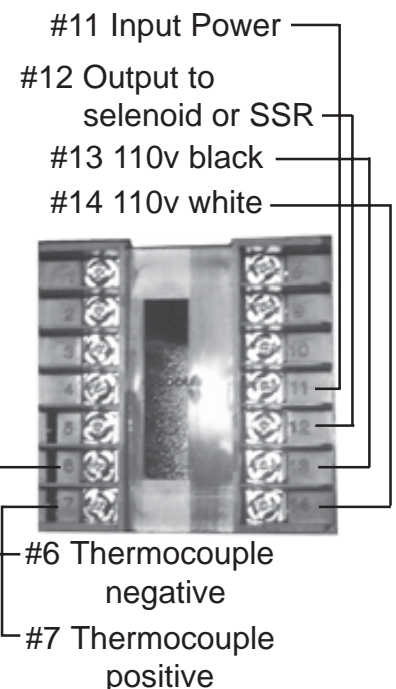

**SPEED CONTROL:** Model **ZRA620**

Speed control is made of three different parts: a digital time panel, a reverse switch for belt direction (for use by serviceman only) and an electronic pcb board.

This control is connected to a tachometer on the back of the gear drive motor which controls the amount of pulses to regulate the speed. This is a closed loop system.

**TO REGULATE SPEED OF BELT (1 - 20 minutes)**

Press for slower rotation of belt (time)



Press for faster rotation of belt (time)

**REVERSAL OF ROTATION:**

You can reverse the rotation of the belt simply by removing the back panel on the control side of oven, locate the tippette switch and push the switch to the desired rotation (to be done by serviceman only).

**NOTE: IF DIRECTION IS CHANGED BE SURE THAT BELT LINKS ARE CHANGED, LINKS SHOULD ALWAYS BE IN PULLING DIRECTION (see page 12)**

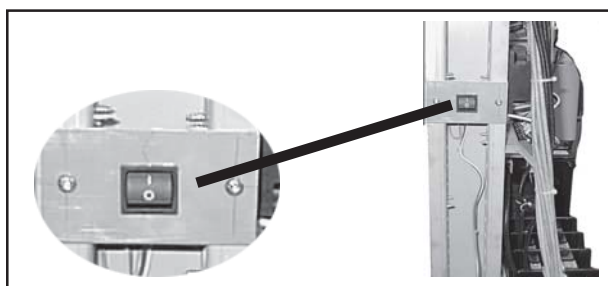
**CAUTION:**

In case of breakage of the electronic board do not touch any component; do not attempt to repair it. Service and calibration of the electronic board require special instruments and must be performed by the factory only. Failure to do so would void the warranty and the replacement of the defective electronic board.

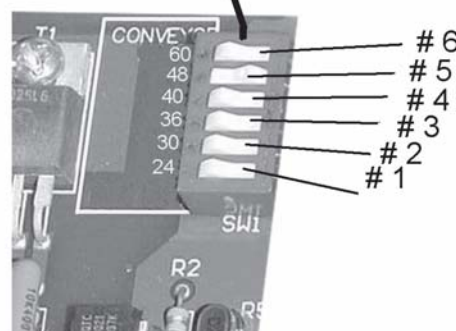
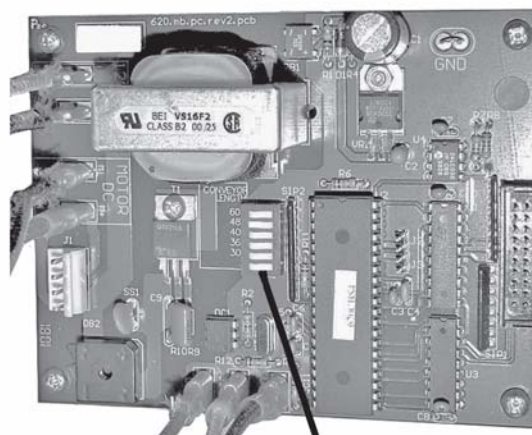

Settings to program different models

Models	Length of belt	Dip switch setting
CE 2416, 2418	48"	#1 (24" chamber)
CG & CE 3018	56"	#2 (30" chamber)
CG & CE 4018	66"	#4 (40" chamber)
CG & CE 3624, 3632	72"	#3 (36" chamber)
CG & CE 4824, 4832	84"	#5 (48" chamber)
CG & CE 6024, 6032	96"	#6 (60" chamber)
CG 4032 DD	72"	#4 (40" chamber)
CG 6532 DD	96"	#6 (60" chamber)

## MAINTENANCE:

REF #0907-53

Periodically, depending on the amount of use and product you are cooking, the oven belt and cavity of the oven must be cleaned.

STEP # 1 Remove both exterior crumb trays daily and wash with soap & water.



STEP # 2 Remove chain cover panel.



STEP # 3 Lift belt and move forward thus loosening chain from belt shaft sprocket.

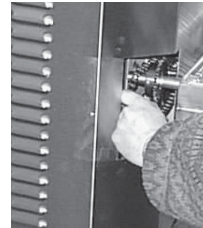

STEP # 4 Now you can remove the belt by carefully pulling back towards you.



STEP # 5 Remove bottom crumb tray first, then bottom air distribution panel and then the top air distribution panel. Cavity is now empty.



To clean interior of oven cavity wash with soap and water. If residue is hard or difficult to clean use a degreaser or abrasive cloth.

**STEP # 6**

It is imperative that the wire netting be kept clean and free of obstructions as this could cause the fan to stop which would result in serious damages to the air circulating motor inside the oven and would void the warranty of this product.

**CLEAN WEEKLY THIS SHOULD BE DONE BY PASSING A DAMP CLOTH OVER WIRE NETTING.**

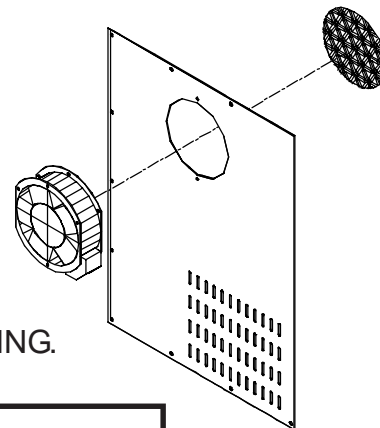
**ATTENTION**

Never use pressure water hose (Jet Spay) to clean oven to prevent any electrical hazards

**REMOVING AND CLEANING WIRE BELT & FRAME:****STEP # 1**

Rotate belt until you find chain link fasteners.

**STEP # 2**

Undo chain link fasteners.

**STEP # 3**

Roll belt and clean. Now you may clean stainless steel frame with soap and water, if residue is hard you may use a degreaser or abrasive cloth.

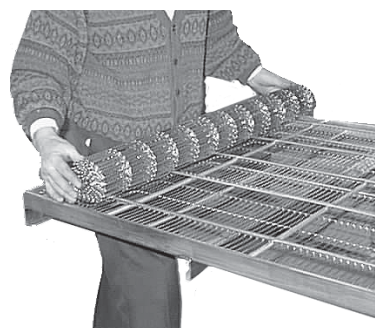

**CONVEYOR BELT ASSEMBLING AND DISASSEMBLING INSTRUCTIONS:**

Install belt so it always runs in the direction indicated by this arrow.  
Closed end of loop towards direction of travel.

The arrows in the belt illustrate the movement of the splicing strand between steps.

When bending the splicing strand, try to limit bending to straight portions of the strand rather than in the "Z" bend area.

Splice one side completely before starting the other side.

After completely splicing the belt, it is advisable to go along the width of the belt straightening the spliced-in strand.

**NOTE: DEPENDING ON WIDTH OF BELT THERE MIGHT BE ONE, TWO OR THREE SPLICING STRANDS.**

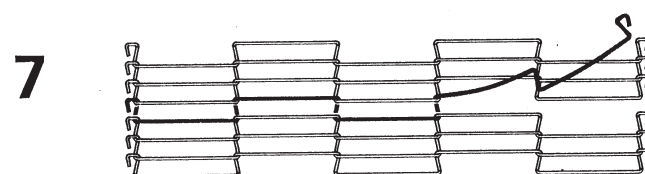
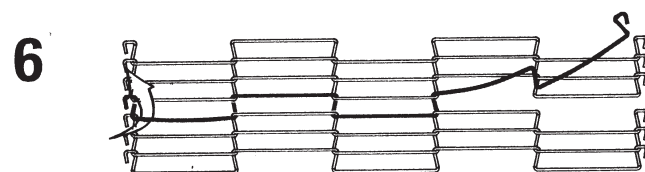
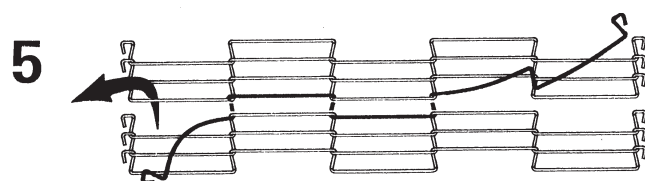
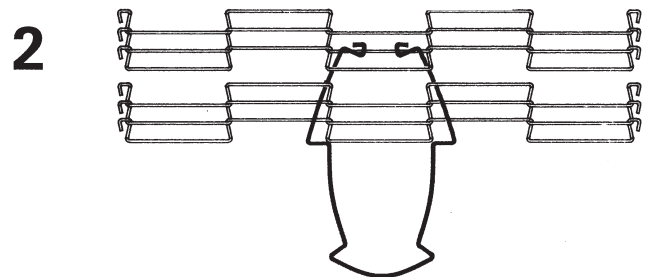
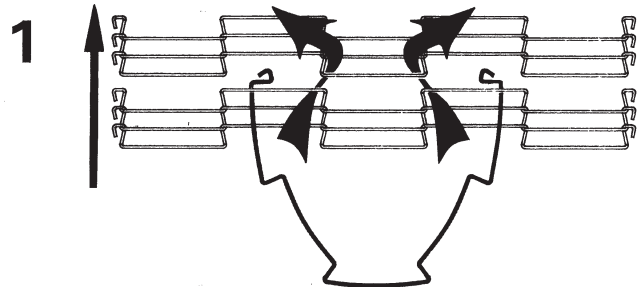



**ADJUSTABLE AIR DISTRIBUTION PANELS:**

**REF #0907-53**

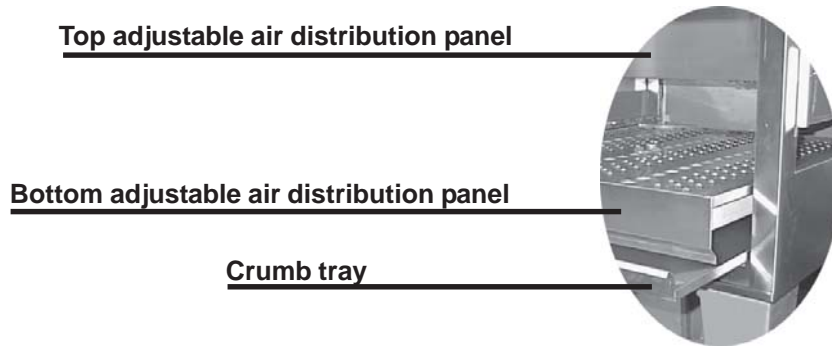

Ovens have a top adjustable air distribution panel, bottom adjustable air distribution panel and crumb tray.



**TOP AIR DISTRIBUTION PANEL**

 Top	MODEL	NUMBER OF CONDUITS	 Top underside
	CE 2416/2418	2	
	CE 3018	2	
	CE 4018	2	
	CE 3632 / 3624	2	
	CE 4832 / 4824	3	
	CE 6032 / 6024	4	
	CE 4032 DD	4	
CE 6532 DD	6		

**BOTTOM AIR DISTRIBUTION PANEL**

 Bottom	MODEL	NUMBER OF CONDUITS	 Bottom underside
	CE 2416/2418	3	
	CE 3018	3	
	CE 4018	4	
	CE 3632 / 3624	4	
	CE 4832 / 4824	5	
	CE 6032 / 6024	6	
	CE 4032 DD	4	
CE 6532 DD	6		



- 1) Lift and pull out front panel with access door.
- 2) Pull out crumb tray.
- 3) Pull out bottom air distribution panel.
- 4) Pull out top air distribution panel.



**AIR DISTRIBUTION PANEL ADJUSTMENT:**

**IMPORTANT NOTICE:** All adjustments on conduits must be set to the same opening. Failing to set the same openings on all conduits will result in uneven cooking and air flow distribution.

Top Air Distribution panel has two adjustments, one for the quantity of air over product and the other to control the distribution of air front to back for even cooking.

**To increase or decrease quantity of air (heat flow) on top of product:**

- (1) Loosen bolts on top of conduits.  
 Pushing top large lever towards the front of the conduit increases the quantity of air on top.  
 Pushing top large lever towards the back of the conduit decreases the quantity of air on top.

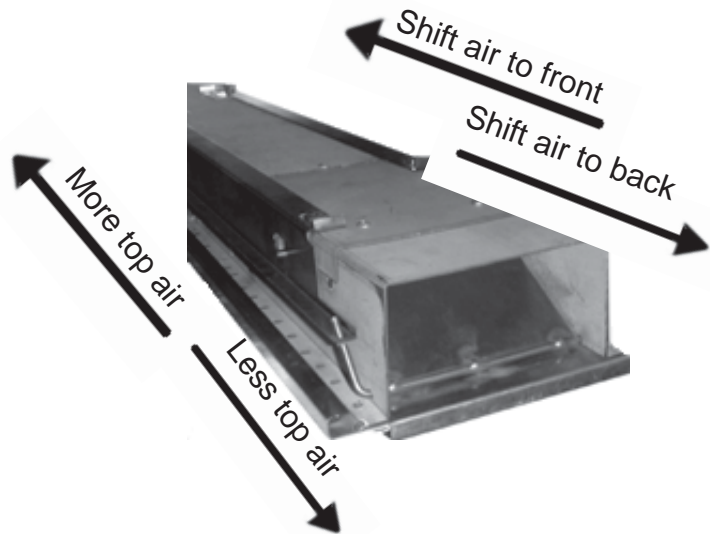

**To shift air in top conduits:**

- (2) Loosen bolts on top of conduits.  
 Pushing top small lever towards the front of the conduit shifts the air to the front.  
 Pushing top small lever towards the back of the conduit shifts the air to the back.

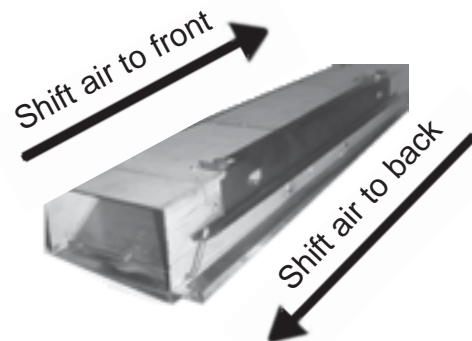

**Bottom Air Distribution panel has one adjustment in each conduit to control the distribution of air from front to back for even cooking.**

Loosen bolts on top of conduits.  
 Pushing top small lever towards the front of the conduit shifts the air to the front.  
 Pushing top small lever towards the back of the conduit shifts the air to the back.

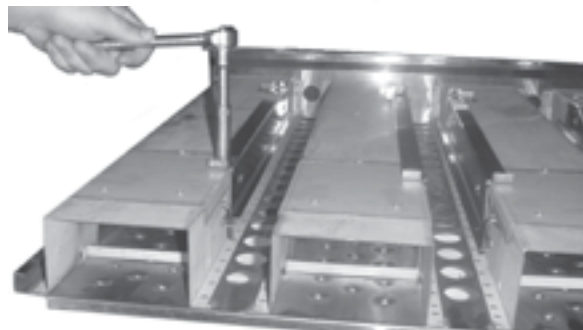

**SEE DIAGRAM PAGE 14**

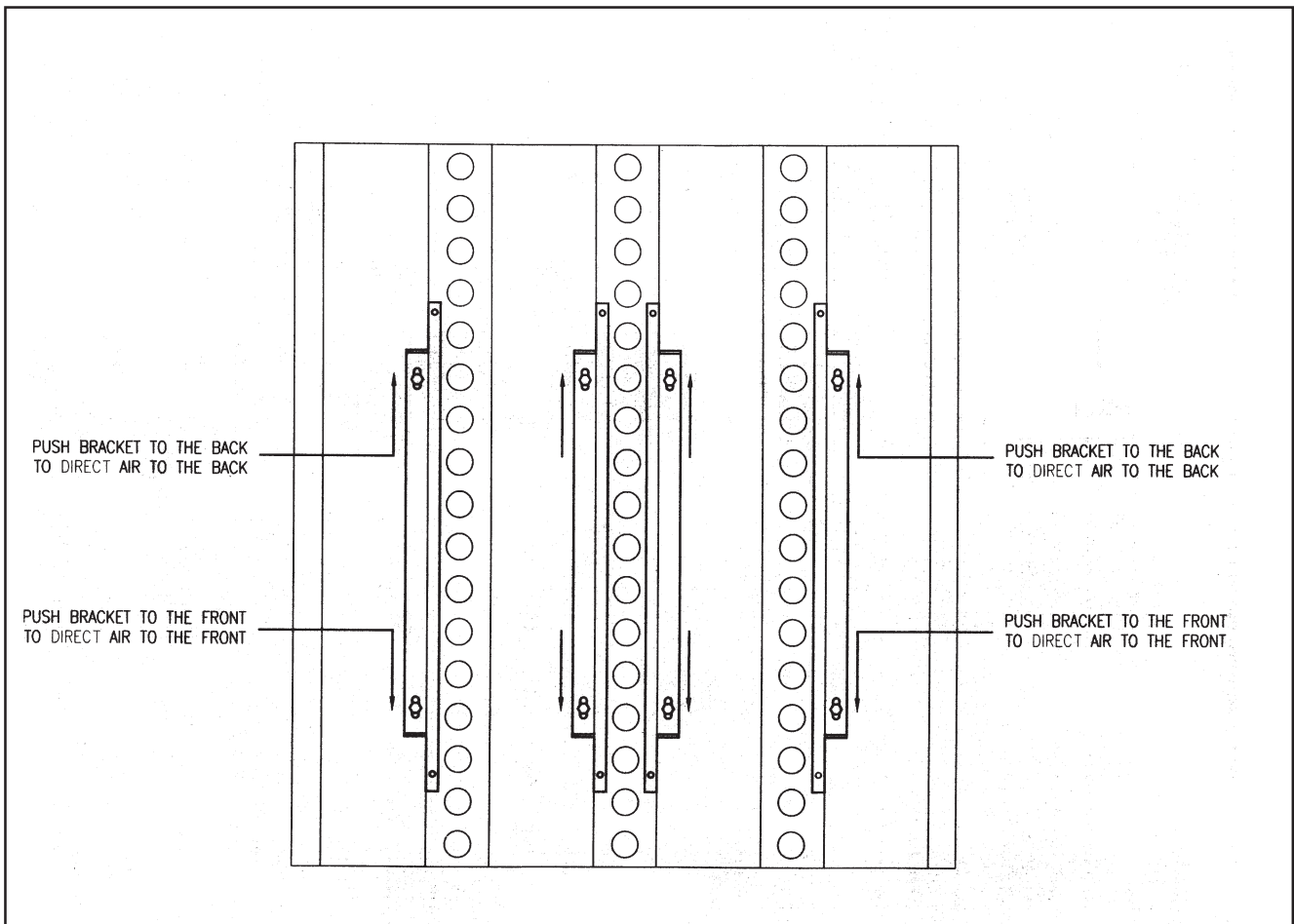
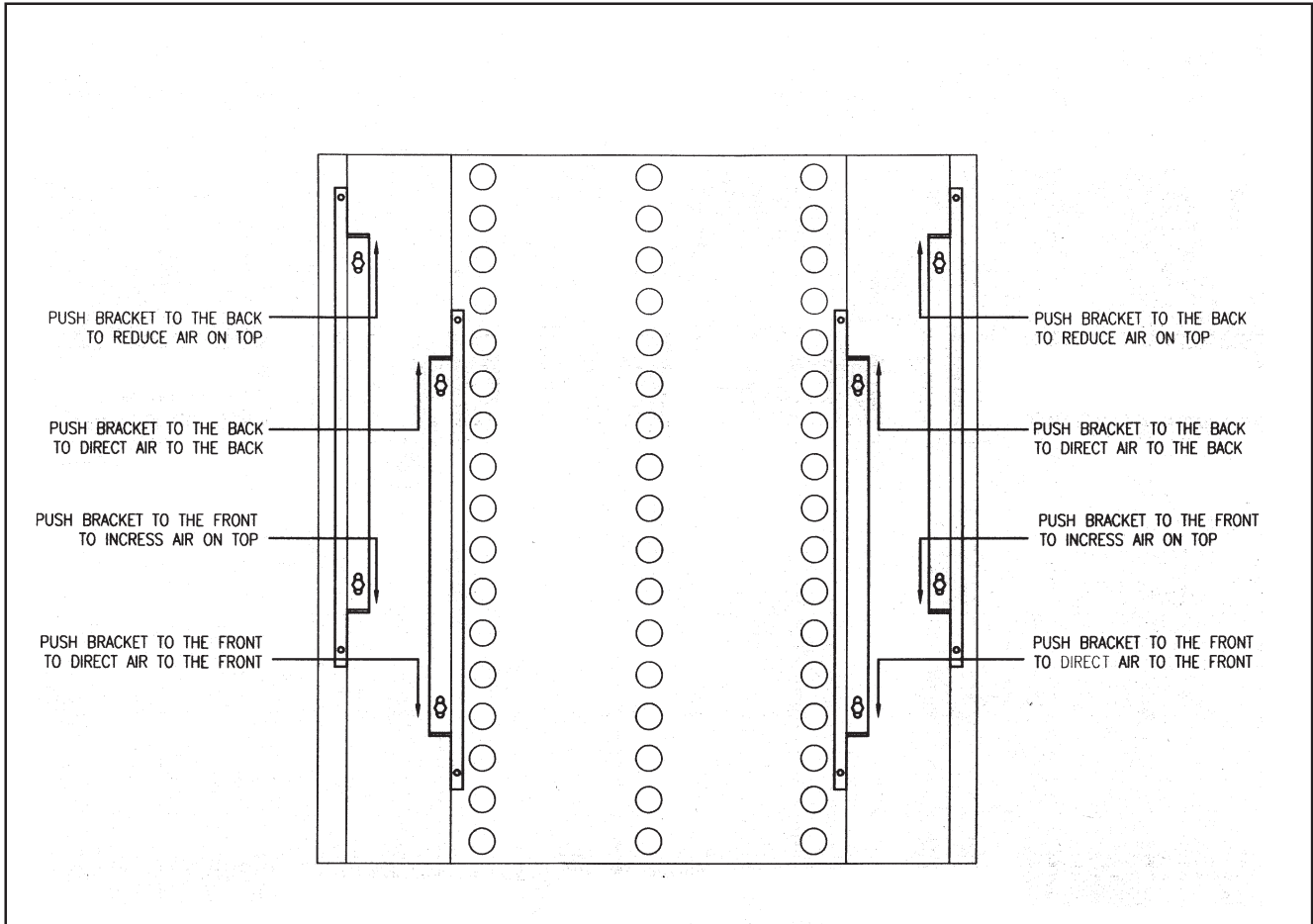

### FACTORY SETTINGS FOR AIR DISTRIBUTION PANELS

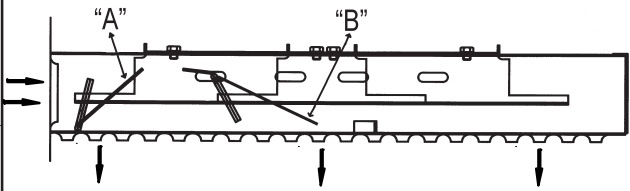
TOP DISTRIBUTION PANEL	<p>"A" Damper to adjust quantity of air distributed on top conduits.</p> <p>"B" Damper to adjust air flow from front to back and back to front.</p> 	MODELS	AIR FLOW SETTINGS	AIR SHIFT SETTINGS
		2416 / 2418	(A) 1/2" (13mm)	(B) 3/8" (9.5mm)
		3018 / 4018	(A) 1/2" (13mm)	(B) 3/8" (9.5mm)
		3624 / 3632	(A) 3/4" (19mm)	(B) 3/8" (9.5mm)
		4824 / 4832	(A) 1/2" (13mm)	(B) 3/8" (9.5mm)
		6024 / 6032	(A) 1/2" (13mm)	(B) 3/8" (9.5mm)

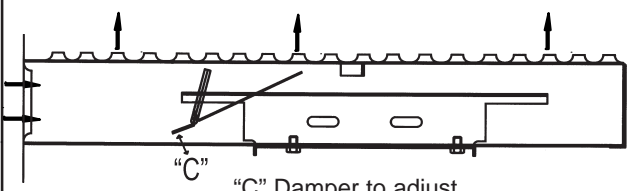
BOTTOM DISTRIBUTION PANEL	<p>"C" Damper to adjust air flow from front to back and back to front.</p> 	MODELS	AIR FLOW SETTINGS	AIR SHIFT SETTINGS
		2416 / 2418	NONE	(C) 3/8" (9.5mm)
		3018 / 4018	NONE	(C) 3/8" (9.5mm)
		3624 / 3632	NONE	(C) 3/8" (9.5mm)
		4824 / 4832	NONE	(C) 3/8" (9.5mm)
		6024 / 6032	NONE	(C) 3/8" (9.5mm)

### THERMOCOUPLE FOR TEMPERATURE CONTROLLER:

The thermocouple placement is very important as the bulb on the end is what directs the temperature controller to signal the burner to give more or less heat in the combustion chamber

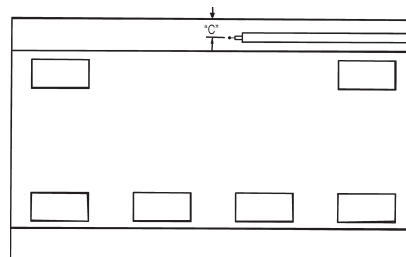
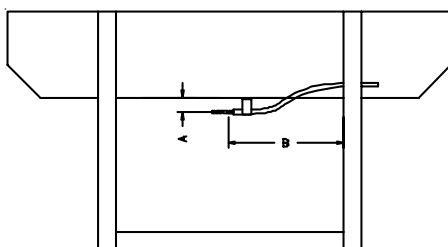

TOP VIEW

FRONT VIEW

MODEL	DIMENSIONS "A"	DIMENSIONS "B"	DIMENSIONS "C"
2416 / 2418	2 1/4" (57mm)	7 1/16" (180mm)	1/2" (13mm)
3018	2 1/4" (57mm)	9 5/8" (245mm)	1/2" (13mm)
4018	2 1/4" (57mm)	10 3/4" (273mm)	1/2" (13mm)
3632 / 3624	1 3/4" (45mm)	16" (407mm)	1 3/16" (30mm)
4832 / 4824	1 3/4" (45mm)	17 3/16" (436mm)	1 3/16" (30mm)
6032 / 6024	1 3/4" (45mm)	19 1/16" (484mm)	1 3/16" (30mm)

**THERMOCOUPLE TEST:** With your Ohmmeter test the thermocouple to see if you have continuity. If continuity your thermocouple should be good. Then test the one wire of your thermocouple against the body of the oven and if you have continuity the thermocouple is defective. The thermocouple should have +/- 1.1 ohms between terminals.

# TECHNICAL SECTION FOR SERVICE

## ELECTRICAL HEATING SYSTEM:

The system used to heat the oven and transfer the heat to the product to be cooked is by having the return air of the cavity circulate over hot open element coils. This is controlled by a thermostat set to your desired temperature.

MODEL	QUANTITY CLOSED COILS
CE 2416 / 2418	3
CE 3018 / 4018	3
CE 3624 / 3632	6
CE 4824 / 4832	9
CE 6024 / 6032	9
CE 4032 DD	12
CE 6532 DD	15

## To remove elements follow the steps below.

**STEP # 1:** Disconnect from power source. Remove side panel carefully by first removing screws holding temperature and speed control and then remaining screws.



**STEP # 2:** Remove wires, components and screws holding hinged panel.

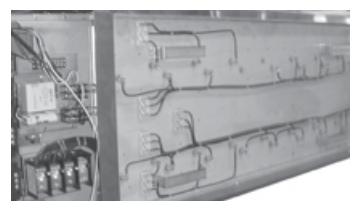
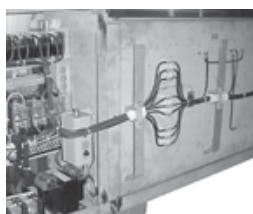

Closed coil type

**STEP # 3:** Remove screws & wires from element box and proceed to remove complete box from oven.

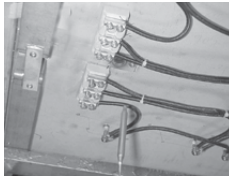
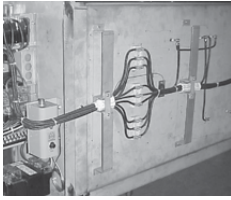

**STEP # 4:** Once removed you can clean with a vacuum the interior of heat chamber if necessary.



Closed coil type



Open back

**STEP # 5:** With element box removed you can now change elements.



### **HI-LIMIT CUT-OFF & TIME DELAY:**

This unit has a Hi-Limit cut-off protection and time delay control card. The Hi-limit cut off and shutdown the heating elements in the oven if the interior heat rises above the permitted level. This control also verifies at the beginning of the cycle that all the components are properly functioning. Any failure the system shuts down a red light appears on the front panel and must then be reset. Reset by depressing the reset button in front panel.



Hi-Limit light.

Reset button.

When the oven is shut off the **TIME DELAY** option starts allowing the belt and fans to remain on (without the heat source) for about 10 minutes to allow the oven components to cool down,

**GEAR MOTOR:**



2416, 2418, 3018 & 4018

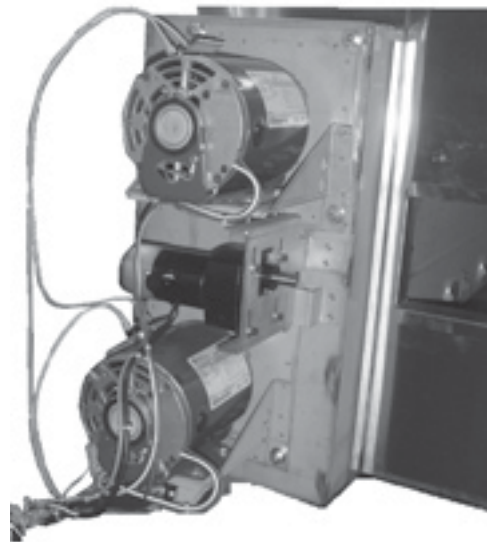

3624, 3632, 4824, 4832, 6024, 6032  
4032DD & 653DD

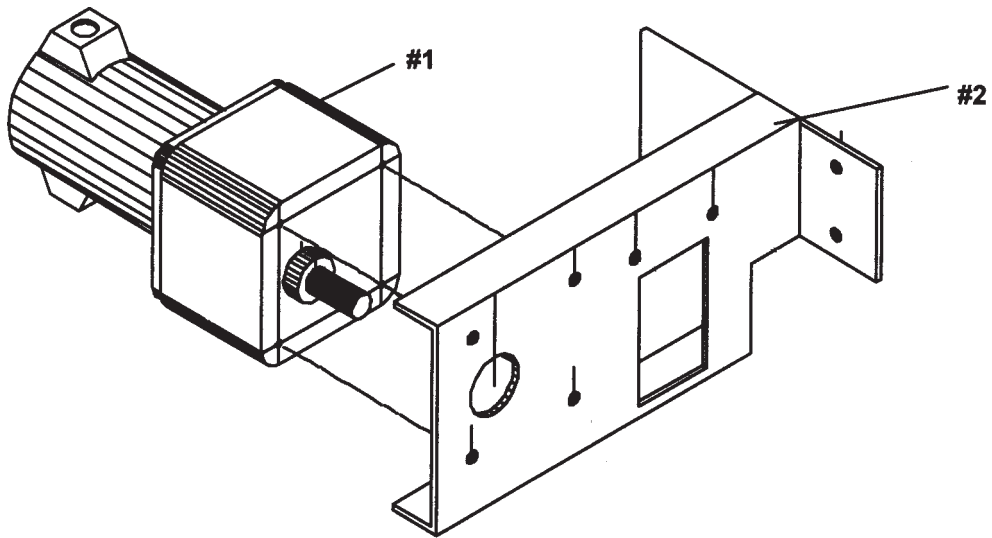

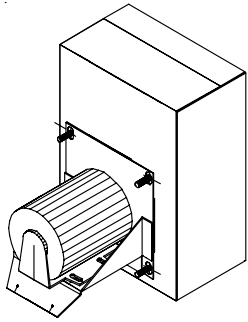

## STEP #1

2416, 2418, 3018 & 4018

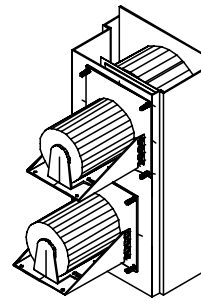

3624, 3632, 4824, 4832, 6024, 6032  
4032DD & 653DD

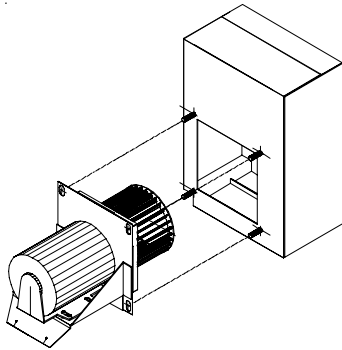

## STEP #2

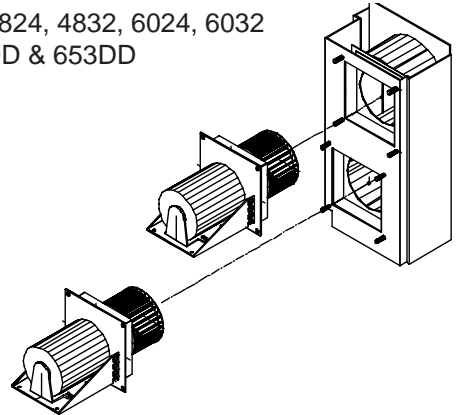

## STEP #3

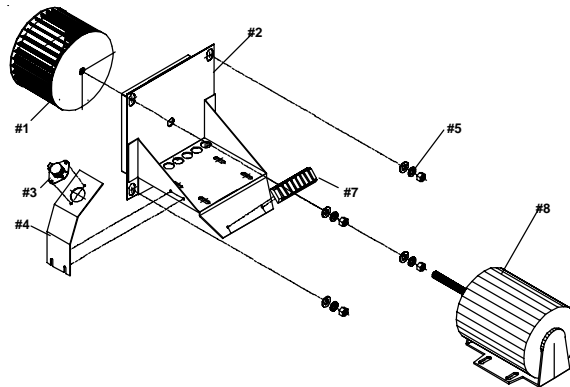

### *Vibrations and noises generated by the Heat Circulating Blower Motors*

1. Make sure the bolts and nuts on the motor bracket are correctly fixed.
2. If everything is in place as indicated and the motor is still noisy, you will have to disassemble the motor to be able to check the blower cage: if the blower cage is not properly balanced, this could generate vibrations and noises.

### *Disassembling the motor:*

1. Remove the chain guard of the belt.
2. Remove the chain from the gear sprocket.
3. Remove the back panel.
4. Remove the stainless steel panel.
5. Remove the locking nuts holding the blower assembly.
6. Press down on the back of the motor to disengage the bracket from the slot and pull out the blower assembly towards you.
7. Start the motor to verify the blower balance; make sure nothing will come in contact with the blower cage. If the blower cage is defective, remove it taking care to verify the exact position of the hub on the motor shaft in order to install correctly the new blower cage.

**Note:** An improper installation of the new blower cage which could come in contact with the outer casing would result in the immediate breakage of the blower cage.

**Important:** When following the procedure in reverse to reassemble the motor, ensure that all the parts are in place before using the oven.

A cooling fan is installed on the left side, at the back of the unit. The function of this fan is to maintain the ambient temperature surrounding the motors at the proper level as recommended in the standard. It is imperative that the wire netting be kept clean and free of obstructions as this could cause the fan to stop which would result in serious damages to the air circulating motor inside the oven and would void the warranty of this product.

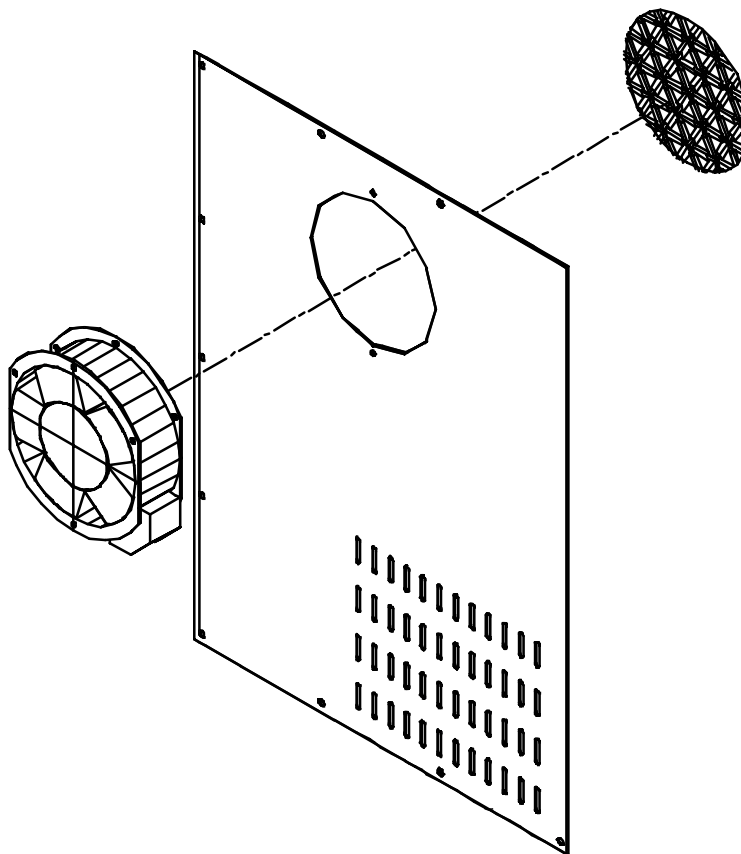
**WARNING**

INTAKE FANS AND SLOTS ON REAR PANELS MUST BE CLEANED WEEKLY.  
ANY OBSTRUCTIONS WILL CAUSE MOTORS TO SEIZE.

**AVERTISSEMENT**

LES PRISES D'AIR ET LES OUVERTURES DANS LES PANNEAUX ARRIÈRES DOIVENT ÊTRE  
NETTOYÉS À TOUTES LES SEMAINES.  
TOUT BLOCAGE DE CES OUVERTURES PEUT FAIRE SAISIR LES MOTEURS.

ELECTRICAL DIAGRAM: 208V, 220V, 240V - 1 PHASES

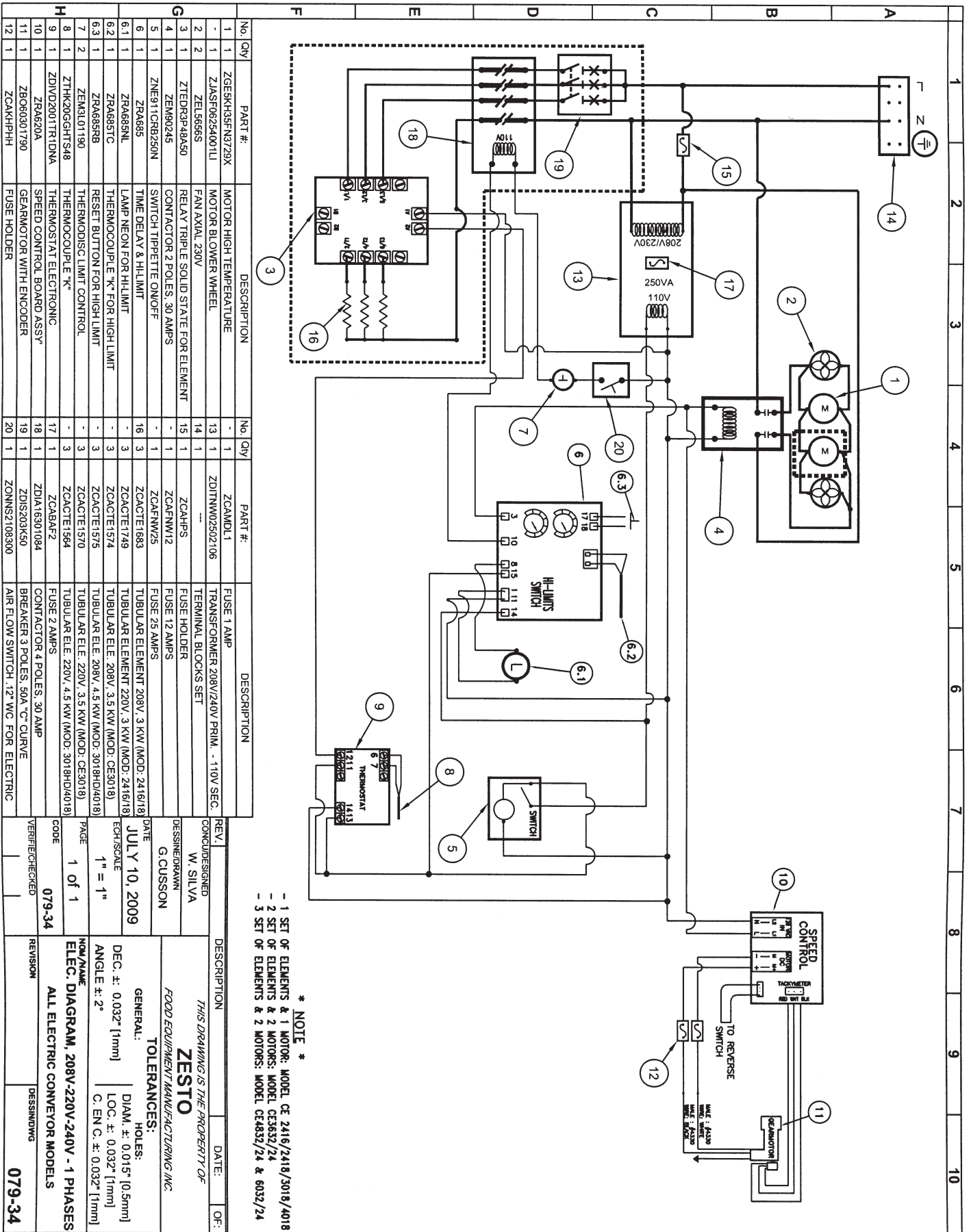

ELECTRICAL DIAGRAM: 208V, 220V, 240V - 3 PHASES

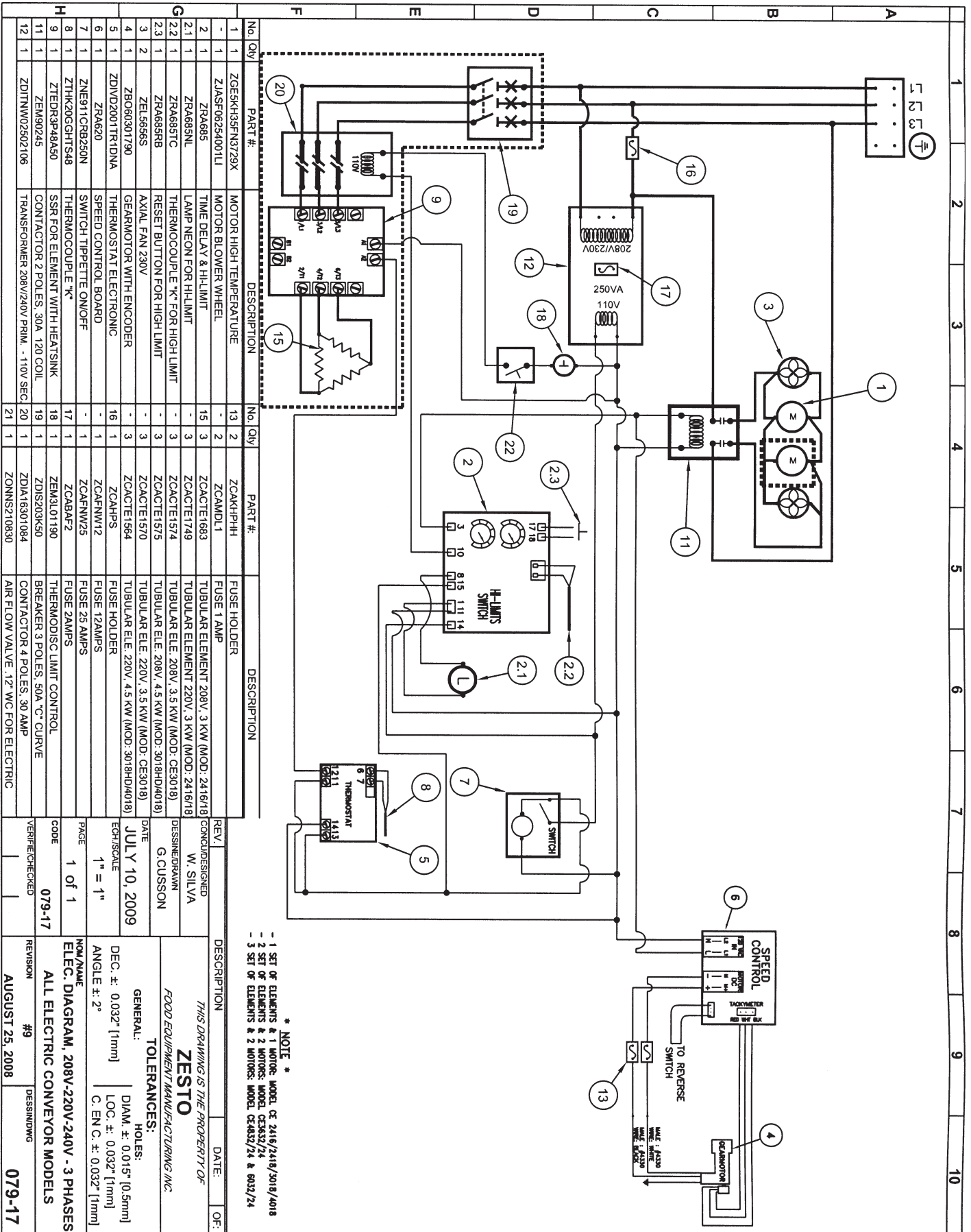

CONVEYOR MODEL: CE2416/18, CE3018, CE4018, CE3632/24, CE4832/24 & CE6032/24

REV.: 1, 2008-11-13

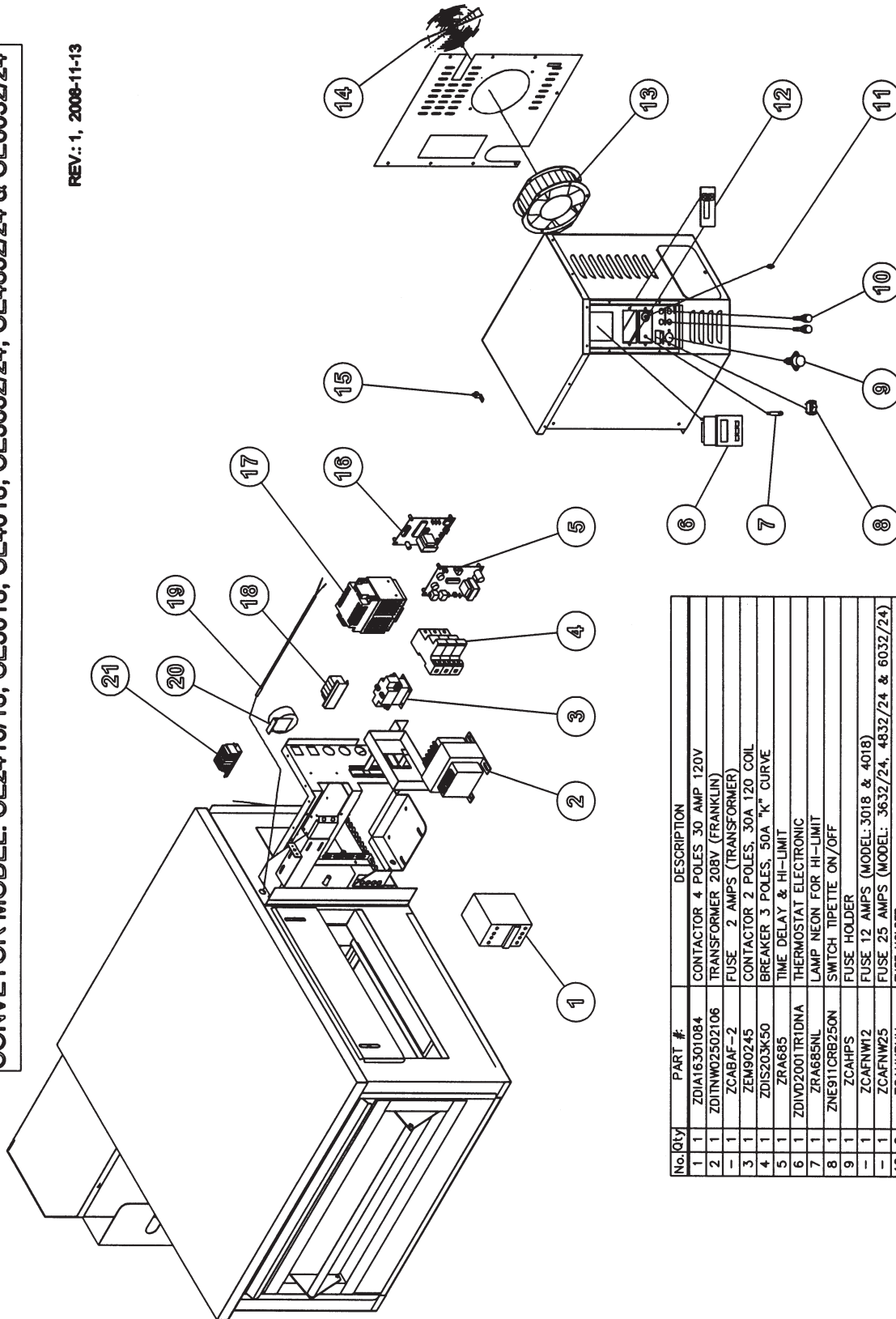

No. Qty	PART #	DESCRIPTION
1	ZDIA16301084	CONTACTOR 4 POLES 30 AMP 120V
2	ZDITN02502106	TRANSFORMER 208V (FRANKLIN)
-	ZCABAF-2	FUSE 2 AMPS (TRANSFORMER)
3	ZEM90245	CONTACTOR 2 POLES, 30A 120 COIL
4	ZDIS203K50	BREAKER 3 POLES, 50A "K" CURVE
5	ZRA685	TIME DELAY & HI-LIMIT
6	ZDIVD2001TRIDNA	THERMOSTAT ELECTRONIC
7	ZRA685NL	LAMP NEON FOR HI-LIMIT
8	ZNE911CRB250N	SWITCH TIPETTE ON/OFF
9	ZCAHPS	FUSE HOLDER
-	ZCAFNW12	FUSE 12 AMPS (MODEL: 3018 & 4018)
-	ZCAFNW25	FUSE 25 AMPS (MODEL: 3632/24, 4832/24 & 6032/24)
10	ZCAHPPHH	FUSE HOLDER
-	ZCAMDL1	FUSE 1 AMP
11	ZRA685RB	RESET BUTTON FOR HIGHT LIMIT
12	ZRA620KD	SPEED BOARD DISPLAY PAD
13	ZEL5656S	AXIAL FAN 230V
14	ZGR4YD91	FAN AXIAL COVER GUARD 6"
15	ZLUSLU70S	LUG CONNECTOR (SOLDERLESS) (FOR ELECTRIC)
16	ZRA620	SPEED CONTROL BOARD
17	ZTEDR3R48A50	SSR FOR ELEMENT WITH HEATSINK
18	-	JUNCTION BLOCKS ASS'Y (W/GROUND)
19	ZTHK206GHTS48	THERMOCOUPLE "K"
20	ZONNS2108300	AIR FLOW SWITCH
21	-	JUNCTION BLOCKS ASS'Y

CONVEYOR MODEL: CE2416/2418, CG/E3018, CG/E4018, CG/E3632/24, CG/E4832/24, CG/E6032/24

REV.: 2, 2008-11-14

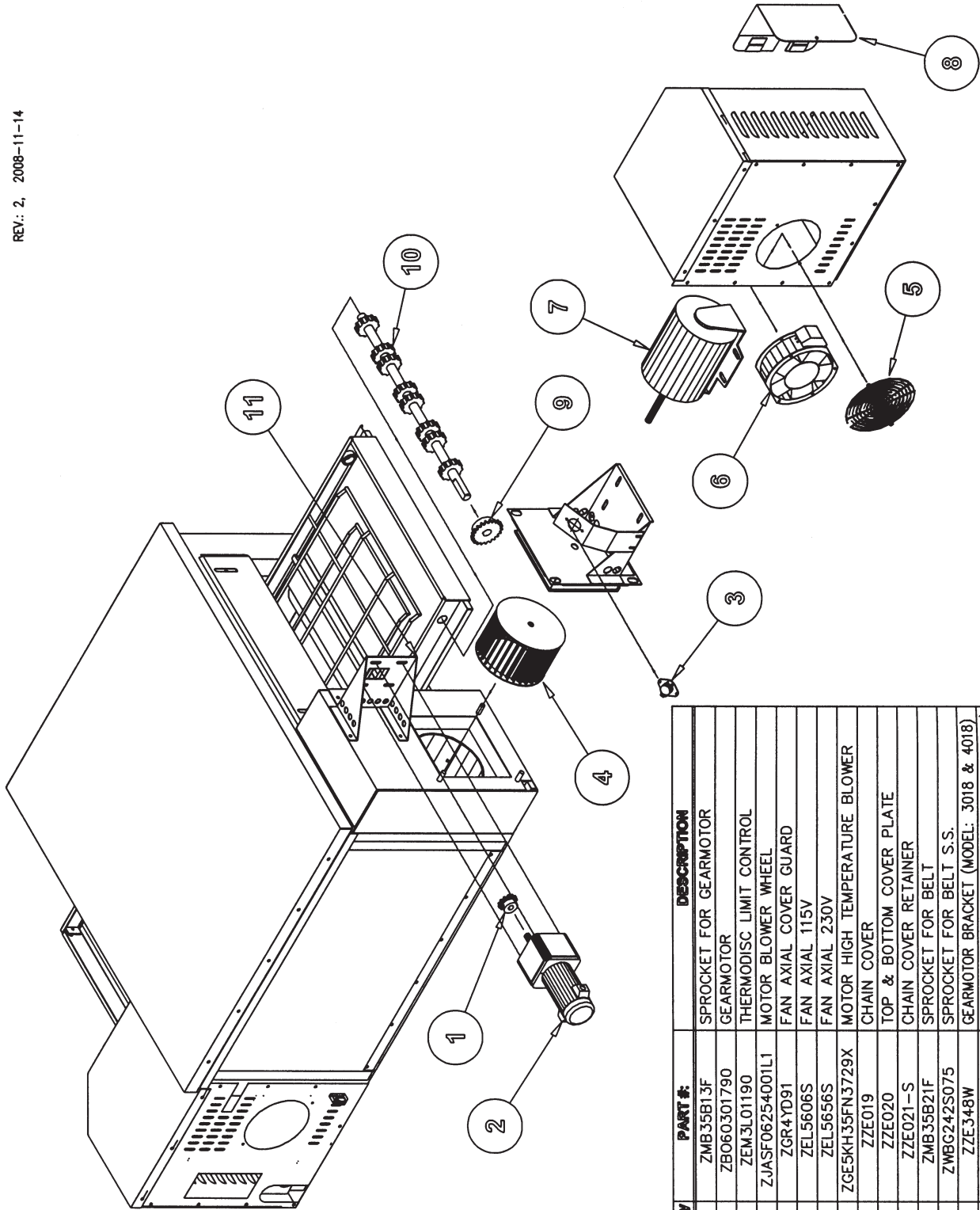

No. Qty	PART #:	DESCRIPTION
1	ZMB35B13F	SPROCKET FOR GEARMOTOR
2	ZB060301790	GEARMOTOR
3	ZEM3L01190	THERMIDISC LIMIT CONTROL
4	ZJASF06254001L1	MOTOR BLOWER WHEEL
5	ZGR4YD91	FAN AXIAL COVER GUARD
6	ZEL5606S	FAN AXIAL 115V
-	ZEL5656S	FAN AXIAL 230V
7	ZGE5KH35FN3729X	MOTOR HIGH TEMPERATURE BLOWER
8	ZZE019	CHAIN COVER
-	ZZE020	TOP & BOTTOM COVER PLATE
-	ZZE021-S	CHAIN COVER RETAINER
9	ZMB35B21F	SPROCKET FOR BELT
10	ZWBG242S075	SPROCKET FOR BELT S.S.
11	ZZE348W	GEARMOTOR BRACKET (MODEL: 3018 & 4018)
-	ZZEASY0191	GEARMOTOR BRACKET (MODEL: 36, 48 & 60)
-	ZZEASY0541	GEARMOTOR BRACKET (MODEL: 2416 & 2418)

# TROUBLE SHOOTING CHART

PROBLEM	POSSIBLE CAUSE	CORRECTIVE ACTION
The main switch is on and unit will not operate.	120 volts power supply or fuses defective.	Replace the fuses.
Problem remains with 120 volts power supply at terminal strip.	Defective connectors at main switch (bad connection).	Replace defective connectors.
	Defective switch.	Replace switch.
The switch is « ON » but the oven doesn't start.	Check power supply for Solid State relay.	Replace.
Speed control shows «OL».	The belt is stuck.	Check the belt.
	The D.C. motor is overloaded.	Replace the motor.
Belt does not turn.	Problem with D.C. voltage supply of the Zesto speed control.	Replace the speed control.
	Gear too loose.	Tighten the allen screw of the gear.
Belt jumps.	Chain too loose.	Adjust tension of the chain.
Cooking is not even.	Improper adjustment of the fingers.	See instructions in the manual.
Oven is operating and there is no heat.	Check hi-limit switch light if on (red light) in control panel.	If red push reset button. If it does not reset and starts heating verify that axial fans are working. Verify axial fan, if functioning verify air flow switch.
Oven is operating, temperature controller is « ON » and the heating elements go off.	Axial fan has stopped.	Replace axial fan.
	Fan circulating motor is overloaded or overheating.	Replace motor.
	Axial fan installed the wrong side (airflow going the wrong way).	Change the direction of airflow.
	Oven installed too close to the wall.	Relocate the oven.
	Defective elements.	Replace elements.
Excessive vibrations of the circulating motor.	The blower cage is unbalanced.	Replace the blower cage.

**COOKING CHART**

(time &amp; temperature will vary according to your product)

	PRODUCT	TIME approx. minutes	TEMP. (F°)/(C°)
<b>ITALIAN</b>	PIZZA (par baked dough)	4 to 4.5 min	510 / 265
	PIZZA (fresh dough)	5.5 to 6.5 min	510 / 265
	PIZZA (thick pan type)	7.5 to 8.5 min	510 / 265
	CALZONE (fresh dough)	5 to 6 min	510 / 265
	PASTAS (pre-cooked to gratine)	5 to 6 min	510 / 265
<b>BREADS &amp; SUBS</b>	GARLIC BREAD	2.5 to 3.5 min	510 / 265
	BREAD STICKS	2.5 to 3.5 min	510 / 265
	SUBMARINE SANDWICHES	2.5 to 3.5 min	510 / 265
<b>BAKERY</b>	DINNER ROLLS (par baked)	4 to 4.5 min	390 / 199
	DINNER ROLLS (fresh)	7.5 to 8.5 min	390 / 199
	BAGELS (fresh)	12 to 13 min	390 / 199
	CROISSANTS (par baked)	4 to 4.5 min	390 / 199
	CROISSANTS (fresh)	9 to 10 min	390 / 199
	MUFFINS (fresh)	12 to 13 min	390 / 199
	BISCUITS & COOKIES (fresh)	4.5 to 6.5 min	390 / 199
<b>MEAT &amp; POULTRY</b>	CHICKEN WINGS (pre-cooked)	5.5 to 6.5 min	510 / 265
	CHICKEN WINGS (fresh)	18 to 20 min	390 / 199
	CHICKEN BREASTS (boneless)	5.5 to 6.5 min	510 / 265
	B.B.Q. RIBS (fresh)	18 to 20 min	390 / 199
	HAMBURGER PATTIES (fresh)	5.5 to 6.5 min	510 / 265
<b>FISH &amp; SEAFOOD</b>	SHRIMP (fresh)	4.5 to 5.5 min	510 / 265
	FISH FILETS (fresh)	6.5 to 7.5 min	510 / 265
	TUNA STEAK (fresh)	8.5 to 9.5 min	510 / 265
	SALMON STEAK (fresh)	6 to 7.5 min	510 / 265
<b>MEXICAN</b>	BURRITOS & ENCHILADAS	2.5 to 3.5 min	475 / 246
	NACHOS ASSORTED STYLES	2.5 to 3.5 min	475 / 246
<b>EGGS</b>	SOUFFLES & OMELETTES	5.5 to 6.5 min	510 / 265
	QUICHES	9 to 10 min	390 / 199

# WARRANTY

## LIMITED WARRANTY

*(CANADA AND CONTINENTAL UNITED STATES OF AMERICA ONLY)*

*WARRANTOR WARRANTS TO THE ORIGINAL CONSUMER PURCHASER THAT THE EQUIPMENT WILL BE FREE FROM DEFECTS IN MATERIALS AND WORKMANSHIP, UNDER NORMAL USE AND SERVICE FOR A PERIOD OF ONE YEAR FROM THE DATE OF PURCHASE.*

*THIS WARRANTY SHALL BE VOID AND HAVE NO EFFECT IF THE EQUIPMENT IS NOT PROPERLY INSTALLED AND MAINTAINED IN ACCORDANCE WITH THE INSTALLATION INSTRUCTIONS MANUAL PROVIDED WITH THE PRODUCT.*

### WARRANTY LIMITATIONS

*DURING THE FIRST YEAR OF THE LIMITED WARRANTY (CANADA & CONTINENTAL U.S.A. ONLY) ZESTO WILL PROVIDE REPLACEMENT PARTS AT NO CHARGE AND WILL ALSO PAY FOR REASONABLE LABOUR COSTS FOR REPAIR WORK (EXCEPT FOR REFRIGERATION, 90 DAYS LABOUR ONLY) DURING REGULAR WORKING HOURS. ALL WARRANTY REPAIRS MUST BE APPROVED BY AN AUTHORIZED COMPANY OFFICIAL BEFORE ANY WORK IS DONE. LABOUR COSTS TO BE BORNE BY ZESTO MUST NOT EXCEED THE RETAIL PRICE OF THE PARTS REPLACED.*

*ALL REQUESTS FOR RE-IMBURSEMENT OF CHARGES MUST BE ACCOMPANIED BY THE MODEL AND SERIAL NUMBER OF THE OVEN UNDER WARRANTY.*

*THE REMEDY FOR DAMAGES AS THE RESULT OF ANY DEFECTS IN THE PRODUCT WHICH HAVE BEEN WARRANTED HEREIN IS LIMITED TO REPLACEMENT PARTS AND DOES NOT INCLUDE ANY INCIDENTAL OR CONSEQUENTIAL DAMAGES OR EXPENSES SUSTAINED IN CONNECTION WITH THE PRODUCT, INCLUDING DAMAGES TO PROPERTY.*

### EXCEPTIONS TO WARRANTY

*THIS WARRANTY DOES NOT APPLY TO DAMAGES IN TRANSIT OR DAMAGES DUE TO INCORRECT WIRING, VOLTAGE OR GAS PRESSURE; MISUSE OR ABUSE OF EQUIPMENT; FIRE; OR FAILURE TO CLEAN ACCORDING TO OUR INSTRUCTIONS.*

*WARRANTY VALID ONLY TO ORIGINAL PURCHASER.*

## **ZESTO**

**FOOD EQUIPMENT MANUFACTURING INC.**

**MANUFACTURIER D'EQUIPEMENT EN ALIMENTATION INC.**

6450 HUTCHISON, MONTREAL, QUEBEC, H2V 4C8 TEL(514)278-4621 FAX(514)278-4622

e-mail: [info@zesto.ca](mailto:info@zesto.ca)

[www.zesto.ca](http://www.zesto.ca)