

# INSTALLATION MANUAL

## SINGLE PACKAGE AIR CONDITIONER / GAS HEAT MODELS: PCG4 Series 3 THRU 5 TONS – 208/230V - 3 PHASE



### LIST OF SECTIONS

GENERAL INFORMATION . . . . .	1	AIRFLOW PERFORMANCE . . . . .	11
SAFETY . . . . .	1	OPERATION . . . . .	14
MODEL NUMBER NOMENCLATURE . . . . .	2	TYPICAL WIRING DIAGRAMS . . . . .	20
INSTALLATION . . . . .	2	START UP SHEET . . . . .	23

### LIST OF FIGURES

Component Location . . . . .	3	Flue Vent Outlet Air Hood . . . . .	10
Center of Gravity Location . . . . .	4	Gas Valve . . . . .	17
Unit Dimensions . . . . .	5	Reading Gas Pressure . . . . .	17
Bottom Duct Dimensions (inches) . . . . .	6	Measuring External Static Pressure . . . . .	18
Rear Duct Dimensions (inches) . . . . .	6	Connection Wiring Diagram . . . . .	20
Typical Field Control Wiring Diagram For Gas Heat - AC Models . . . . .	7	Ladder Wiring Diagram . . . . .	21
Typical Field Power Wiring Diagram . . . . .	7	R-410A Quick Reference Guide . . . . .	22

### LIST OF TABLES

Unit Limitations . . . . .	3	Natural Gas Application Data . . . . .	10
Weights and Dimensions . . . . .	4	Propane (LP) Gas Application Data . . . . .	11
Unit Dimensions . . . . .	5	Airflow Performance - Side Duct Application . . . . .	11
Unit Clearances, . . . . .	5	Airflow Performance - Bottom Duct Application . . . . .	12
Electrical Data . . . . .	7	Additional Static Resistance . . . . .	14
Physical Data . . . . .	8	Ignition Control Board Flash Codes . . . . .	15
Natural Gas Pipe Sizing Chart . . . . .	9	Inlet Gas Pressure Range . . . . .	16
Propane (LP) Gas Pipe Sizing Chart . . . . .	9	Nominal Manifold Pressure . . . . .	17
High Altitude Gas Orifice Sizing . . . . .	10	Gas Rate Cubic Feet Per Hour . . . . .	19

## SECTION I: GENERAL INFORMATION

These are electric cooling/gas heating units designed for outdoor installation. Only gas piping, electric power and duct connections are required at the point of installation.

The gas-fired heaters have spark ignition.

The refrigerant system is fully charged with R-410A Refrigerant, and is tested and factory sealed.

## SECTION II: SAFETY



This is a safety alert symbol. When you see this symbol on labels or in manuals, be alert to the potential for personal injury.

Understand and pay particular attention to the signal words **DANGER**, **WARNING**, or **CAUTION**.

**DANGER** indicates an **imminently** hazardous situation, which, if not avoided, **will result in death or serious injury**.

**WARNING** indicates a **potentially** hazardous situation, which, if not avoided, **could result in death or serious injury**.

**CAUTION** indicates a potentially hazardous situation, which, if not avoided **may result in minor or moderate injury**. It is also used to alert against unsafe practices and hazards involving only property damage.

## ▲ WARNING

*Improper installation may create a condition where the operation of the product could cause personal injury or property damage. Improper installation, adjustment, alteration, service or maintenance can cause injury or property damage. **Failure to carefully read and follow all instructions in this manual can result in furnace malfunction, death, personal injury and/or property damage.** Only a qualified contractor, installer or service agency should install this product.*

## ▲ CAUTION

*This product must be installed in strict compliance with the installation instructions and any applicable local, state, and national codes including, but not limited to building, electrical, and mechanical codes.*

**⚠ WARNING**

Before performing service or maintenance operations on unit, turn off main power switch to unit. Electrical shock could cause personal injury. Improper installation, adjustment, alteration, service or maintenance can cause injury or property damage. Refer to this manual. For assistance or additional information consult a qualified installer, service agency or the gas supplier.

**⚠ CAUTION**

This system uses R-410A Refrigerant which operates at higher pressures than R-22. No other refrigerant may be used in this system. Gage sets, hoses, refrigerant containers and recovery systems must be designed to handle R-410A. If you are unsure, consult the equipment manufacturer. Failure to use R-410A compatible servicing equipment may result in property damage or injury.

**⚠ WARNING**

If the information in this manual is not followed exactly, a fire or explosion may result causing property damage, personal injury or loss of life.

Do not store or use gasoline or other flammable vapors and liquids in the vicinity of this or any other appliance.

**WHAT TO DO IF YOU SMELL GAS:**

1. Do not try to light any appliance.
2. Do not touch any electrical switch; do not use any phone in your building.
3. Immediately call your gas supplier from a neighbor's phone. Follow the gas supplier's instructions.
4. If you cannot reach your gas supplier, call the fire department.

Installation and service must be performed by a qualified installer, service agency or the gas supplier.

Due to system pressure, moving parts, and electrical components, installation and servicing of air conditioning equipment can be hazardous. Only qualified, trained service personnel should install, repair, or service this equipment. Untrained personnel can perform basic maintenance functions of cleaning coils and filters and replacing filters.

Observe all precautions in the literature, labels, and tags accompanying the equipment whenever working on air conditioning equipment. Be sure to follow all other applicable safety precautions and codes including ANSI Z223.1 or CSA-B149.1- latest edition.

Wear safety glasses and work gloves. Use quenching cloth and have a fire extinguisher available during brazing operations.

**SECTION III: MODEL NUMBER NOMENCLATURE**

PCG	4	A	24	050	3	X	1	A
1	2	3	4	5	6	7	8	9
<b>1. Model Family</b> PCG - packaged A/C with gas heat, PCE - packaged A/C with electric heat, PHE - packaged heat pump with electric heat <b>2. Nominal Cooling Efficiency</b> 4 = 14 SEER, 6 = 16 SEER, etc. <b>3. Cabinet Size</b> A = small 35 x 51, B = large 45 x 51 <b>4. Nominal Air Conditioning Cooling Capacity</b> 24 = Nominal Capacity, etc. <b>Examples:</b> PCG4B4210023X1A is a packaged A/C with gas heat, 14 SEER, 3-1/2 ton, large cabinet, three-stage heat, 100,000 BTU gas heat, 230 volt, three phase, low-NOx model (first generation, first release)	<b>5. Gas Heating Input BTU/Hr x 1000</b> 050 = 50,000 BTU/Hr. input, blank = electric heat <b>6. Voltage-Phase-Frequency</b> 2 = 208/230-1-60, 3=208/230-3-60, 4 = 460-3-60 <b>7. NOx Approval</b> X = low-NOx, blank = not low-NOx <b>8. Generation Level</b> 1 = first generation <b>9. Revision Level</b> A = original release, B = second release							

**SECTION IV: INSTALLATION****INSTALLATION SAFETY INFORMATION**

Read these instructions before continuing this appliance installation. This is an outdoor combination heating and cooling unit. The installer must assure that these instructions are made available to the consumer with instructions to retain them for future reference.

1. Refer to the unit rating plate for the approved type of gas for this product.
2. Install this unit only in a location and position as specified on Page 4 of these instructions.
3. Never test for gas leaks with an open flame. Use commercially available soap solution made specifically for the detection of leaks when checking all connections, as specified on Page 10 of these instructions.

4. Always install unit to operate within the unit's intended temperature-rise range with the duct system and within the allowable external static pressure range, as specified on the unit name/rating plate, specified in Table 6 of these instructions.
5. This equipment is not to be used for temporary heating of buildings or structures under construction.

**⚠ WARNING****FIRE OR EXPLOSION HAZARD**

Failure to follow the safety warning exactly could result in serious injury, death or property damage.

Never test for gas leaks with an open flame. use a commercially available soap solution made specifically for the detection of leaks to check all connections. A fire or explosion may result causing property damage, personal injury or loss of life.

## LIMITATIONS

These units must be installed in accordance with the following:

### In U.S.A.:

1. National Electrical Code, ANSI/NFPA No. 70 - Latest Edition
2. National Fuel Gas Code, ANSI Z223.1 - Latest Edition
3. Gas-Fired Central Furnace Standard, ANSI Z21.47a. - Latest Edition
4. Local building codes, and
5. Local gas utility requirements

### In Canada:

1. Canadian Electrical Code, CSA C22.1
2. Installation Codes, CSA - B149.1.
3. Local plumbing and waste water codes, and
4. Other applicable local codes.

Refer to unit application data found in this document.

After installation, gas fired units must be adjusted to obtain a temperature rise within the range specified on the unit rating plate.

If components are to be added to a unit to meet local codes, they are to be installed at the dealer's and/or customer's expense.

Size of unit for proposed installation should be based on heat loss/heat gain calculation made according to the methods of Air Conditioning Contractors of America (ACCA).

This furnace is not to be used for temporary heating of buildings or structures under construction.

**Table 1:** Unit Limitations

Model	Unit Voltage	Unit Limitations		
		Applied Voltage		Outdoor DB Temp
		Min	Max	Max (°F)
A36	208/230-3-60	187	252	125
A42	208/230-3-60	187	252	125
B48	208/230-3-60	187	252	125
B60	208/230-3-60	187	252	125

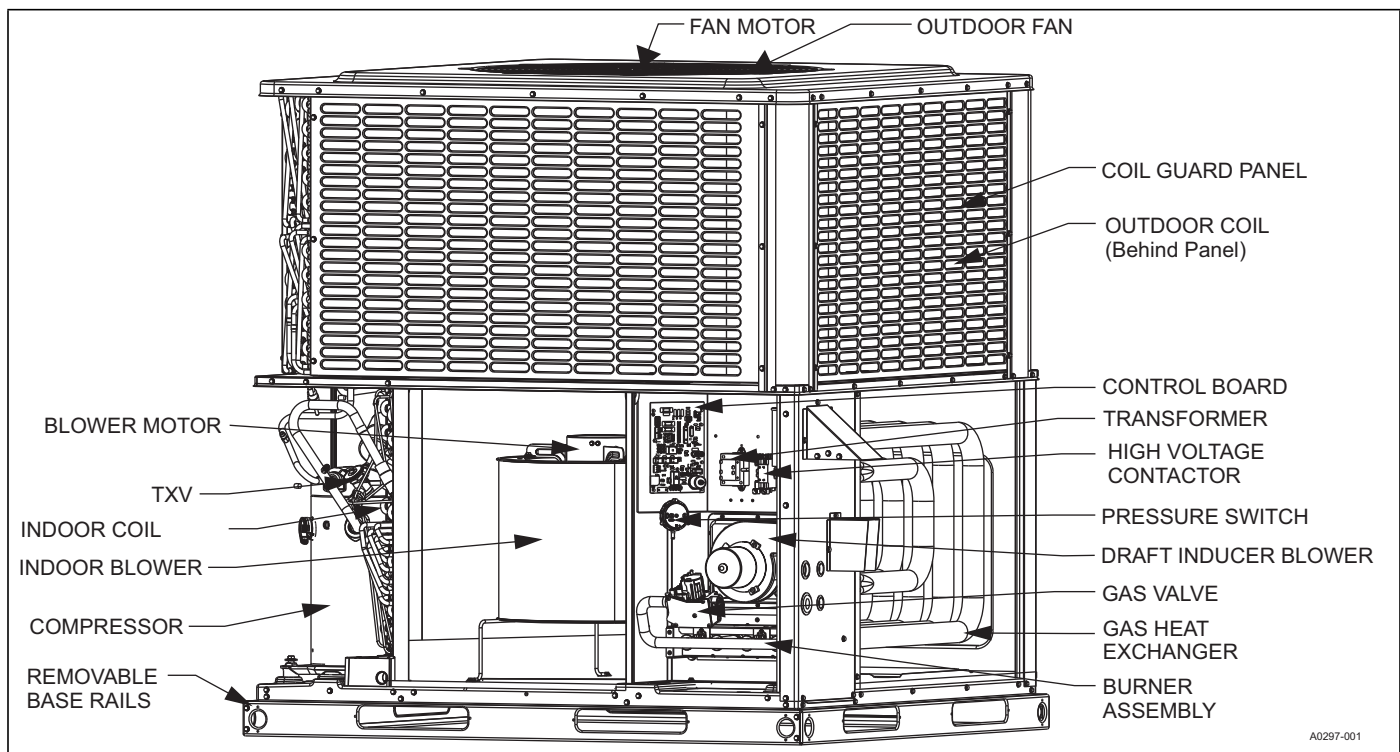

**FIGURE 1:** Component Location

## LOCATION

Use the following guidelines to select a suitable location for these units:

1. Unit is designed for **outdoor installation** only.
2. Condenser coils must have an unlimited supply of air. Where a choice of location is possible, position the unit on either north or east side of building.
3. Suitable for mounting on roof curb.

## ⚠ WARNING

*Do not attach supply and return duct work to the bottom of the unit base pan as the drain pan could be compromised.*

4. For ground level installation, a level pad or slab should be used. The thickness and size of the pad or slab used should meet local codes and unit weight. Do not tie the slab to the building foundation.
5. Roof structures must be able to support the weight of the unit and its options/accessories. Unit must be installed on a solid, level roof curb or appropriate angle iron frame.

6. Maintain level tolerance to 1/8" across the entire width and length of unit.

**⚠ WARNING**

*Excessive exposure of this unit to contaminated combustion air may result in equipment damage or personal injury. Typical contaminants include: permanent wave solution, chlorinated waxes and cleaners, chlorine based swimming pool chemicals, water softening chemicals, carbon tetrachloride, Halogen type refrigerants, cleaning solvents (e.g. perchloroethylene), printing inks, paint removers, varnishes, hydrochloric acid, cements and glues, anti-static fabric softeners for clothes dryers, masonry acid washing materials.*

**CLEARANCES**

All units require particular clearances for proper operation and service. Installer must make provisions for adequate combustion and ventilation air in accordance with section 5.3 of Air for Combustion and Ventilation of the National Fuel Gas Code, ANSI Z223.1 – Latest Edition (in U.S.A.), or Sections 7.2, 7.3, or 7.4 of Gas Installation Codes, CSA-B149.1 (in Canada) - Latest Edition, and/or applicable provisions of the local building codes. Refer to Table 4 for clearances required for combustible construction, servicing, and proper unit operation.

**⚠ WARNING**

*Do not permit overhanging structures or shrubs to obstruct condenser air discharge outlet, combustion air inlet or vent outlets.*

**Table 2:** Weights and Dimensions

Model	Weight (lbs.)		Center of Gravity		4 Point Load Location (lbs.)			
	Shipping	Operating	X	Y	A	B	C	D
36050	425	420	28	15	141	107	94	78
36075	432	427	28	15	135	115	103	74
36100	436	431	28	15	139	113	99	80
42075	446	441	28	15	145	112	99	85
42100	448	443	28	15	148	110	96	89
48065	520	515	28	15	189	116	93	117
48100	528	523	28	15	169	139	115	100
48125	533	528	28	15	164	145	124	95
60065	537	532	29	15	174	142	124	92
60100	541	536	28	15	177	140	117	102
60125	548	543	27	15	151	167	141	84

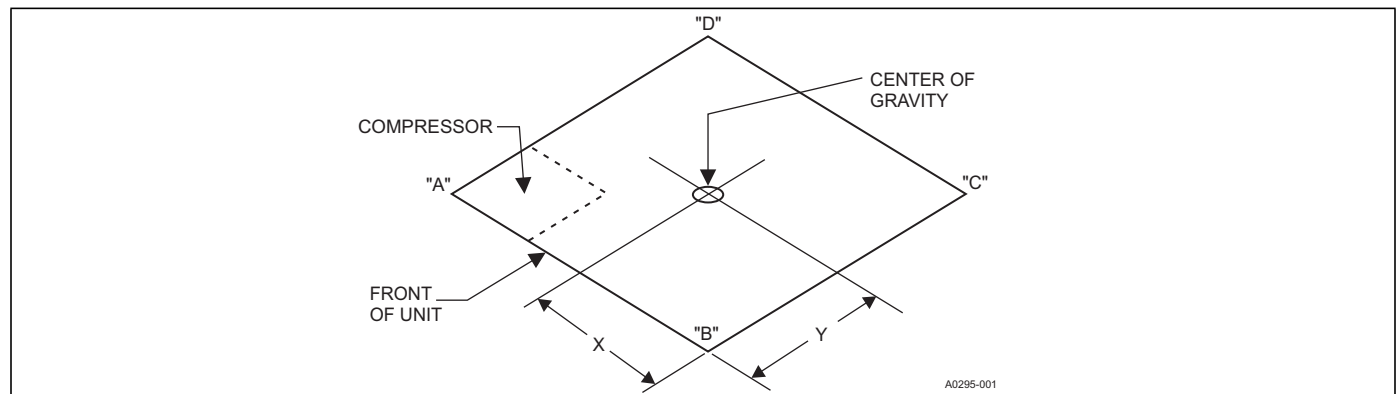

**FIGURE 2:** Center of Gravity Location

**RIGGING AND HANDLING**

**⚠ CAUTION**

*All panels must be secured in place when the unit is lifted. The condenser coils should be protected from rigging cable damage with plywood or other suitable material.*

**⚠ CAUTION**

*If a unit is to be installed on a roof curb other than a Unitary Products roof curb, gasket or sealant must be applied to all surfaces that come in contact with the unit underside.*

Exercise care when moving the unit. Do not remove any packaging until the unit is near the place of installation. Rig the unit by attaching chain or cable slings to the lifting holes provided in the base rails. Spreader bars, whose length exceeds the largest dimension across the unit, **MUST** be used across the top of the unit.

**⚠ CAUTION**

*Before lifting, make sure the unit weight is distributed equally on the rigging cables so it will lift evenly.*

Units may be moved or lifted with a forklift. Slotted openings in the base rails are provided for this purpose.

**Table 3:** Unit Dimensions

Model	Dimensions		
	A	B	C
A36	51-1/4	35-3/4	47
A42	51-1/4	35-3/4	49
B48	51-1/4	45-3/4	53
B60	51-1/4	45-3/4	55

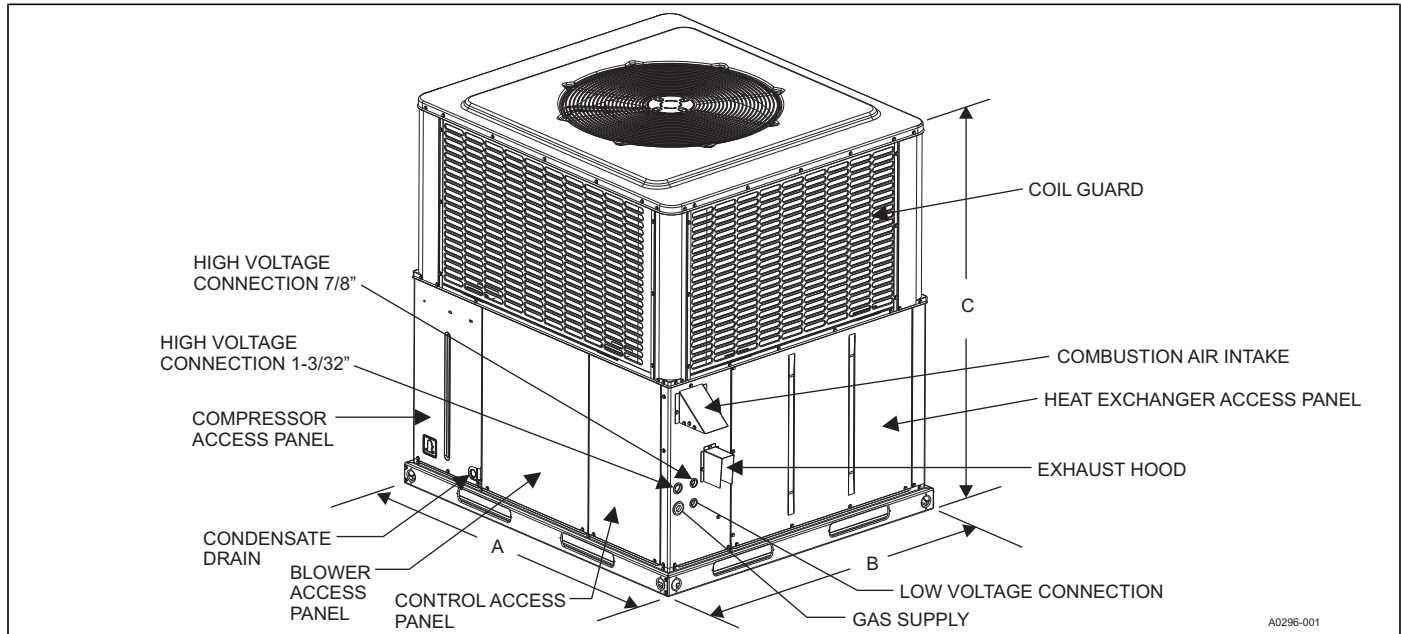

A0296-001

**FIGURE 3:** Unit Dimensions**Table 4:** Unit Clearances<sup>1,2</sup>

Direction	Distance (in.)	Direction	Distance (in.)
Top <sup>3</sup>	36	Power Entry (Right Side)	36
Side Opposite Ducts	36	Left Side	24
Duct Panel	0	Bottom <sup>4</sup>	1

1. A 1" clearance must be provided between any combustibile material and the supply air duct work.
2. The products of combustion must not be allowed to accumulate within a confined space and recirculate.
3. Units must be installed outdoors. Over hanging structure or shrubs should not obstruct condenser air discharge outlet.
4. Units may be installed on combustibile floors made from class A, B or C roof covering materials.

DUCTWORK

**NOTICE**

*All units are shipped in the horizontal supply/return configuration. It is important to reduce the possibility of any air leakage through the bottom duct covers (resulting from cut, torn, or rolled gasket) due to improper handling or shipping processes. To ensure a good tight seal, it is recommended that silicone caulk and/or foil tape be applied along the cover edges.*

These units are adaptable to downflow use as well as rear supply and return air duct openings. To convert to downflow, use the following steps:

1. Remove the duct covers found in the bottom return and supply air duct openings.
2. Install the duct covers (removed in step one) to the rear supply and return air duct openings.
3. Seal duct covers with silicone caulk.

Duct work should be designed and sized according to the methods of the Air Conditioning Contractors of America (ACCA), as set forth in their Manual D.

A closed return duct system shall be used. This shall not preclude use of economizers or ventilation air intake. Flexible joints are recommended to be used in the supply and return duct work to minimize the transmission of vibration and noise.

**NOTICE**

*Be sure to note supply and return openings.*

Refer to Figures 5 and 6 for information concerning rear and bottom supply and return air duct openings.

**FILTERS**

Proper filter size is very important. Filter size, type and pressure drop should always be considered during duct system design.

It is the responsibility of the installer to secure a filter in the return air ductwork or utilize the filter rack kit shipped with all three phase models.

A filter rack kit is included with all three phase units.

Filters must always be used and must be kept clean. When filters become dirt laden, insufficient air will be delivered by the blower, decreasing your units efficiency and increasing operating costs and wear-and-tear on the unit and controls.

Filters should be checked monthly; this is especially important since this unit is used for both heating and cooling.

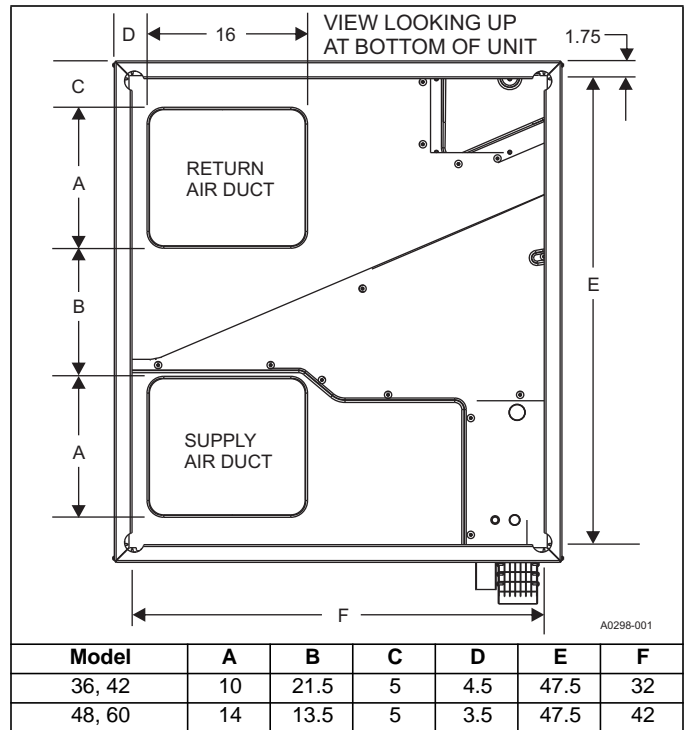

**FIGURE 4:** Bottom Duct Dimensions (inches)

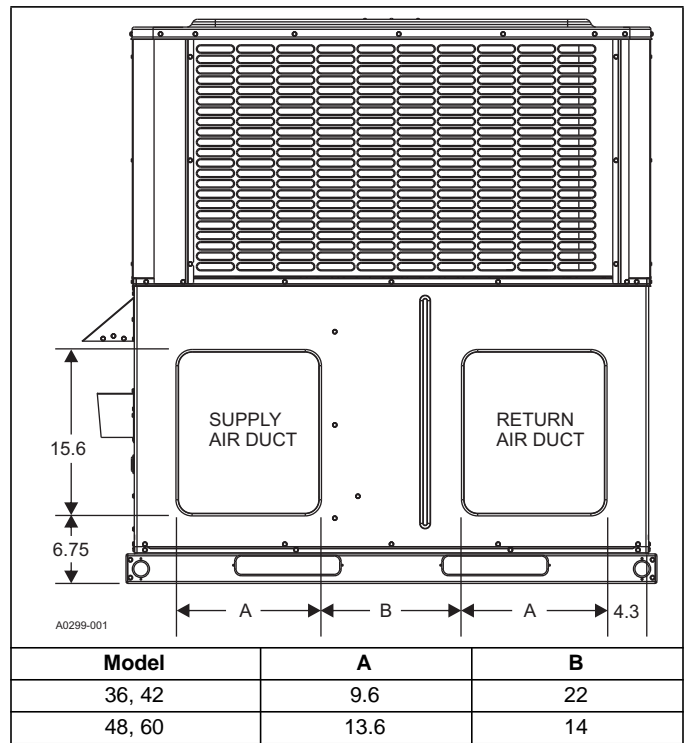

**FIGURE 5:** Rear Duct Dimensions (inches)

**CONDENSATE DRAIN**

A condensate trap must be installed in the condensate drain. The plumbing must conform to local codes.

Use Teflon tape or pipe thread compound if needed.

**⚠ CAUTION**

*Hand tighten only.*

**SERVICE ACCESS**

Access to all serviceable components is provided at the following locations:

- Coil guards
- Unit top panel
- Corner posts
- Blower access panel
- Control access panel
- Indoor coil access panel
- Compressor access panel
- Heat exchanger access panel

Refer to Figure 4 for location of these access locations and minimum clearances in Table 4.

**⚠ CAUTION**

*This system uses R-410A Refrigerant which operates at higher pressures than R-22. No other refrigerant may be used in this system. Gage sets, hoses, refrigerant containers and recovery systems must be designed to handle R-410A. If you are unsure, consult the equipment manufacturer. Failure to use R-410A compatible servicing equipment may result in property damage or injury.*

**⚠ WARNING**

*Wear safety glasses and gloves when handling refrigerants. Failure to follow this warning can cause serious personal injury.*

Refer to Figure 14 for the R-410A Quick Reference Guide.

**THERMOSTAT**

The room thermostat should be located on an inside wall approximately 60" above the floor where it will not be subject to drafts, sun exposure or heat from electrical fixtures or appliances. Sealant should be used behind thermostat to prevent air infiltration. Follow manufacturer's instructions enclosed with the thermostat for general installation procedure. Color coded insulated wires (minimum #18 AWG) should be used to connect thermostat to unit. See Figure 6. Do not use power stealing thermostats.

**POWER AND CONTROL WIRING**

Field wiring to the unit must conform to provisions of the current N.E.C. ANSI/NFPA No. 70 or C.E.C. and/or local ordinances. The unit must be electrically grounded in accordance with local codes or, in their absence, with the N.E.C./C.E.C. Voltage tolerances which must be maintained at the compressor terminals during starting and running conditions are indicated on the unit Rating Plate and Table 1.

The wiring entering the cabinet must be provided with mechanical strain relief.

A fused disconnect switch should be field provided for the unit. If any of the wire supplied with the unit must be replaced, replacement wire must be of the type shown on the wiring diagram.

Electrical service must be sized properly to carry the load. Each unit must be wired with a separate branch circuit fed directly from the main distribution panel and properly fused.

Refer to Figures 6 and 7 for typical field wiring and to the appropriate unit wiring diagram for control circuit and power wiring information.

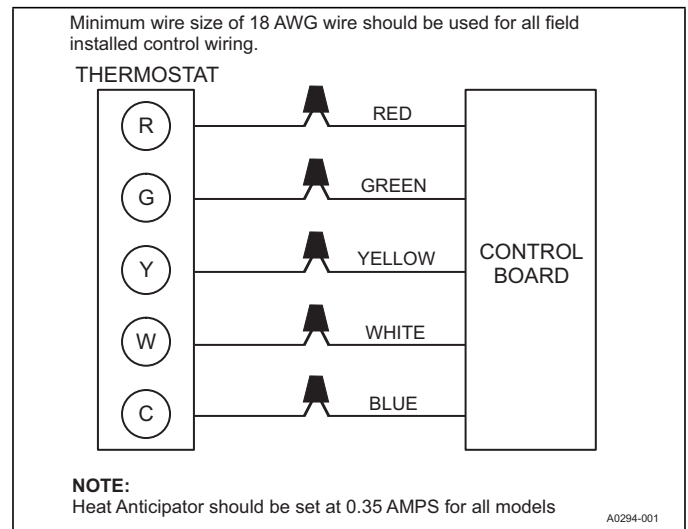

**FIGURE 6:** Typical Field Control Wiring Diagram For Gas Heat - AC Models

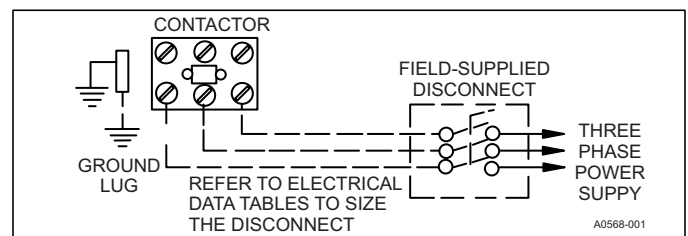

**FIGURE 7:** Typical Field Power Wiring Diagram

**Table 5:** Electrical Data

Model	Voltage	Compressor			Outdoor Fan Motor	Indoor Fan Blower Motor	MCA <sup>1</sup> (Amps)	Max Fuse <sup>2</sup> / Breaker <sup>3</sup> Size (Amps)
		RLA	LRA	MCC	FLA	FLA		
36050, 36075	208/230-3-60	8.3	68.0	14.5	1.3	3.8	15.5	20
36100	208/230-3-60	8.3	68.0	14.5	1.3	5.4	17.1	25
42075, 42100	208/230-3-60	13.5	88.0	21.1	1.3	5.4	23.6	35
48065, 48100, 48125	208/230-3-60	13.7	83.1	21.4	1.7	5.4	24.2	35
60065, 60100, 60125	208/230-3-60	16.0	110.0	24.9	1.7	7.0	28.7	40

1. Minimum Circuit Ampacity.
2. Maximum Over Current Protection per standard UL 1995.
3. Fuse or HACR circuit breaker size installed at factory or field installed.

Table 6: Physical Data

COMPONENT	MODELS											
	A36			A42			B48			B60		
NOMINAL TONNAGE	3.0			3.5			4.0			5.0		
<b>Filters</b>												
<b>AHRI Cooling Performance</b>												
Gross Capacity @ AHRI A point (MBH)	37.2			43.5			47.7			55.0		
AHRI net capacity (MBH)	34.6			41.0			45.5			52.5		
EER	11.0			11.0			11.0			11.0		
SEER	14.0			14.0			14.0			14.0		
Nominal CFM	1200			1400			1600			2000		
System power (KW)	3.2			3.8			4.2			4.8		
Refrigerant type	R410A			R410A			R410A			R410A		
Refrigerant charge (lb-oz)	8-3			9-4			14-4			14-2		
<b>AHRI Gas Heat Performance</b>												
Heating model	50	75	100	75	100	65	100	125	65	100	125	
Heat input (K BTU)	50.0	75.0	100.0	75.0	100.0	65.0	100.0	125.0	65.0	100.0	125.0	
Heat output (K BTU)	40	60	80	60	80	52	80	100	52	80	100	
AFUE%	81.0	81.0	81.0	81.0	81.0	81.0	81.0	81.0	81.0	81.0	81.0	
No. burners	2	3	4	3	4	2	3	4	2	3	4	
No. stages	1	1	1	1	1	1	1	1	1	1	1	
Temperature Rise Range (° F)	35-65	40-70		40-70		40-70			40-70			
Max. Static Pressure w.c.	0.5			0.5			0.5			0.5		
Max. Outlet Air Temp. (° F)	180			180			180			180		
Gas piping connection (in.)	1/2			1/2			1/2			1/2		
<b>Dimensions (inches)</b>												
Length	51-1/4			51-1/4			51-1/4			51-1/4		
Width	35-3/4			35-3/4			45-3/4			45-3/4		
Height	47			49			53			55		
Operating WT. (lbs.)	420	427	431	441	443	515	523	528	532	536	543	
<b>Compressors</b>												
Type	Recip			Scroll			Scroll			Scroll		
<b>Condenser Coil Data</b>												
Face area (Sq. Ft.)	15.1			16.9			23.8			25.9		
Rows	2			2			2			2		
Fins per inch	22			22			22			22		
Tube diameter	3/8			3/8			3/8			3/8		
Circuitry Type	Interlaced			Interlaced			Interlaced			Interlaced		
<b>Evaporator Coil Data</b>												
Face area (Sq. Ft.)	4.6			4.6			6.3			6.3		
Rows	3			3			3			3		
Fins per inch	16			16			16			16		
Tube diameter	3/8			3/8			3/8			3/8		
Circuitry Type	Interlaced			Interlaced			Interlaced			Interlaced		
Refrigerant control	TXV			TXV			TXV			TXV		
<b>Condenser Fan Data</b>												
Fan diameter (Inch)	24			24			26			26		
Type	Prop			Prop			Prop			Prop		
Drive type	Direct			Direct			Direct			Direct		
No. speeds	1			1			1			1		
Motor HP each	1/4			1/4			1/3			1/3		
RPM	850			850			850			850		
Nominal total CFM	2400			2400			3200			3200		
<b>Direct Drive Evaporator Fan Data</b>												
Fan Size (Inch)	11 x 10			11 x 10			11 x 10			11 x 10		
Type	Centrifugal			Centrifugal			Centrifugal			Centrifugal		
Motor HP each	1/2	3/4		3/4		3/4		3/4		1		
RPM	1200 Max			1200 Max			1200 Max			1200 Max		
Frame size	48			48			48			48		
Quantity - Size	Field-supplied external filters must be sized so as not to exceed 300 fpm air velocity through disposable filters. For internal filter use, a filter rack kit is included with all three phase models. Consult the instructions supplied with that kit for replacement filter sizes. Filter sizes: A=20x20, B=20x30.											

## COMPRESSORS

The compressor used in this product is specifically designed to operate with R-410A Refrigerant and cannot be interchanged.

### ⚠ CAUTION

*This system uses R-410A Refrigerant which operates at higher pressures than R-22. No other refrigerant may be used in this system.*

The compressor uses polyolester (POE oil), Mobile 3MA POE. This oil is extremely hygroscopic, meaning it absorbs water readily. POE oil can absorb 15 times as much water as other oils designed for HCFC and CFC refrigerants. If refrigerant circuit is opened, take all necessary precautions to avoid exposure of the oil to the atmosphere.

### ⚠ CAUTION

*Do not leave the system open to the atmosphere. Unit damage could occur due to moisture being absorbed by the POE oil in the system. This type of oil is highly susceptible to moisture absorption*

POE (polyolester) compressor lubricants are known to cause long term damage to some synthetic roofing materials.

### ⚠ CAUTION

*Exposure, even if immediately cleaned up, may cause embrittlement (leading to cracking) to occur in one year or more. When performing any service that may risk exposure of compressor oil to the roof, take precautions to protect roofing.*

Procedures which risk oil leakage include, but are not limited to, compressor replacement, repairing refrigerant leaks, replacing refrigerant components such as filter drier, pressure switch, metering device or coil.

Units are shipped with compressor mountings which are factory-adjusted and ready for operation.

### ⚠ CAUTION

*Do not loosen compressor mounting bolts.*

## PHASING

Three-phase, scroll compressors operate in only one direction. If the scroll is drawing low amperage, has similar suction and discharge pressures, or is producing a high noise level, the scroll is misphased. Change the incoming line connection phasing to obtain the proper rotation.

### ⚠ CAUTION

*Scroll compressors require proper rotation to operate properly. Failure to check and correct rotation may result in property damage.*

## GAS HEAT

These single stage gas-fired heat sections have direct spark ignition.

## GAS PIPING

Proper sizing of gas piping depends on the cubic feet per hour of gas flow required, specific gravity of the gas and the length of run. National Fuel Gas Code Z223.1 or CSA B149.1 should be followed in all cases unless superseded by local codes or gas company requirements. Refer to Tables 7 and 8.

The BTU content of the gas may differ with locality. The value should be checked with the local gas utility.

## NOTICE

*There may be a local gas utility requirement specifying a minimum diameter for gas piping. All units require a 1/2 inch pipe connection at the gas valve.*

## GAS CONNECTION

The gas supply line should be routed through the 1-5/8" hole located on the right side of the unit. See Figure 3 for the location. The unit is supplied with a rubber grommet that fits in this hole and is used to seal around the gas pipe. THIS GROMMET MUST BE INSTALLED IN ORDER TO PREVENT LEAKAGE OF AIR AND WATER INTO THE HEATING/CONTROLS COMPARTMENT.

### Gas piping requirements:

1. A drip leg and a ground joint union must be installed in the gas piping.
2. When required by local codes, a manual shut-off valve may have to be installed outside of the unit.
3. Use wrought iron or steel pipe for all gas lines. Pipe thread sealant should be applied sparingly to male threads only.

**Table 7: Natural Gas Pipe Sizing Chart<sup>1</sup>**

Length In Feet	Nominal Inches Iron Pipe Size			
	1/2"	3/4"	1"	1-1/4"
10	132	278	520	1,050
20	92	190	350	730
30	73	152	285	590
40	63	130	245	500
50	56	115	215	440
60	50	105	195	400
70	46	96	180	370
80	43	90	170	350
90	40	84	160	320
100	38	79	150	305

1. Maximum capacity of pipe in cubic feet of gas per hour (based upon a pressure drop of 0.3 inch water column and 0.6 specific gravity gas).

**Table 8: Propane (LP) Gas Pipe Sizing Chart<sup>1</sup>**

Length In Feet	Nominal Inches Iron Pipe Size			
	1/2"	3/4"	1"	1-1/4"
10	275	567	1071	2,205
20	189	393	732	1496
30	152	315	590	1212
40	129	267	504	1039
50	114	237	448	913
60	103	217	409	834
70	96	196	378	771
80	89	185	346	724
90	83	173	322	677
100	78	162	307	630

1. Maximum capacity of pipe in thousands of BTU per hour (based upon a pressure drop of 0.5 inch water column).

### ⚠ CAUTION

*If flexible stainless steel tubing is allowed by the authority having jurisdiction, wrought iron or steel pipe must be installed at the gas valve and extend a minimum of two (2) inches outside of the unit casing.*

### ⚠ WARNING

*Natural gas may contain some propane. Propane being an excellent solvent, will quickly dissolve white lead or most standard commercial compounds. Therefore, a special pipe thread sealant must be applied when wrought iron or steel pipe is used. Shellac base compounds such as gaskoloc or stalastic, and compounds such as Rectorseal # 5, Clyde's or John Crane may be used.*

- All piping should be cleaned of dirt and scale by hammering on the outside of the pipe and blowing out the loose dirt and scale. Before initial start-up, be sure that all of the gas lines external to the unit have been purged of air.
- The gas supply should be a separate line and installed in accordance with all applicable safety codes. After the gas connections have been completed, open the main shut-off valve admitting normal gas pressure to the gas valve. Check all joints for leaks with soap solution or other material suitable for the purpose. NEVER USE AN OPEN FLAME.

## ▲ WARNING

### FIRE OR EXPLOSION HAZARD

*Failure to follow the safety warning exactly could result in serious injury, death or property damage.*

*Never test for gas leaks with an open flame. Use a commercially available soap solution made specifically for the detection of leaks to check all connections. A fire or explosion may result causing property damage, personal injury or loss of life.*

**Table 9:** High Altitude Gas Orifice Sizing

GAS TYPE	ELEVATION ABOVE SEA LEVEL (FEET)								
	0-2000 (FACTORY)	2001-3000	3001-4000	4001-5000	5001-6000	6001-7000	7001-8000	8001-9000	9001-10000
NATURAL GAS ORIFICE SIZES	36	37	38	38	39	40	41	41	42
	42	42	43	43	43	44	44	45	46
LP GAS ORIFICE SIZES	51	51	52	52	52	52	53	53	53
	54	54	55	55	55	55	55	56	56

### FLUE VENT AND AIR INTAKE HOOD

## ▲ WARNING

*Flue hood surfaces may be hot.*

## ▲ CAUTION

*The flue exhaust hood must be properly installed and within the recommended clearances. Further communications and action must be given to the home or building owner(s) to eliminate any unauthorized human contact around this area during the heating cycle. Flue hood surfaces and the immediate area reach high temperatures during the heating cycle.*

The flue vent hood and air intake hoods are shipped loose. These hoods must be installed to assure proper unit operation. The hoods must be fastened to the outside of the side gas control/electrical compartment with the screws provided. See Figure 8.

**Table 10:** Natural Gas Application Data

Available On Models	Input (MBH) <sup>1</sup> High Fire	Output (MBH) High Fire	Gas Rate <sup>2</sup> Ft. <sup>3</sup> /Hr. High Fire/Low Fire	Number of Burners	Temp. Rise °F At Full Input <sup>3</sup>	
					Min.	Max.
3 Tons	50	41	46	2	35	65
4, 5 Tons	65	53	60	2	40	70
3, 3-1/2 Tons	75	61	70	3	40	70
3, 3-1/2 Tons	100	81	93	4	40	70
4, 5 Tons	100	81	93	3	40	70
4, 5 Tons	125	101	116	4	40	70

1. Heating capacity valid for elevations up to 2000 feet above sea level. For elevations above 2,000 feet, rated capacity should be reduced by 4% for each 1,000 feet above sea level.

2. Based on 1075 BTU/Ft.<sup>3</sup>.

3. The air flow must be adequate to obtain a temperature rise within the range shown. Continuous return air temperature should not be below 55° F.

- The unit and its equipment shutoff valve must be disconnected from the gas supply system during and pressure testing of that system at test pressures in excess of 1/2 psi (3.48 kPa)
- The unit must be isolated from the gas supply piping system by closing its individual manual shut-off valve before conducting any pressure testing of the gas supply piping system at test pressures equal to or less than 1/2 psig (3.48 kPa).

### HIGH ALTITUDE GAS CONVERSION

This furnace is constructed at the factory for natural gas-fired operation at altitudes up to 2,000 feet above sea level. For installations located above 2,000 feet, the gas input rate to the burners must be reduced by 4% per 1,000 feet above sea level. It may be necessary to change to smaller orifices at high altitude. Refer to the table below for the correct orifice size to use.

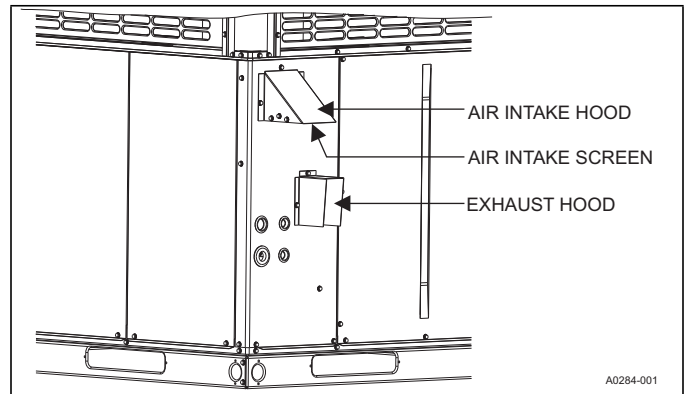

**FIGURE 8:** Flue Vent Outlet Air Hood

**Table 11:** Propane<sup>1</sup> (LP) Gas Application Data

Available On Models	Input Capacity (MBH) <sup>2</sup> High Fire/Low Fire	Output Capacity (MBH) High Fire/Low Fire	Gas Rate <sup>3</sup> Ft. <sup>3</sup> /Hr. High Fire/Low Fire	Number of Burners	Temp. Rise °F At Full Input <sup>4</sup>	
					Min.	Max.
3 Tons	50	41	20	2	35	65
4, 5 Tons	65	53	26	2	40	70
3, 3-1/2 Tons	75	61	30	3	40	70
3, 3-1/2 Tons	100	81	40	4	40	70
4, 5 Tons	100	81	40	3	40	70
4, 5 Tons	125	101	50	4	40	70

1. Propane applications are accomplished by field installation of a Propane Conversion Accessory Kit. For more information, see the Accessories section in the Technical Guide.
2. Heating capacity valid for elevations up to 2,000 feet above sea level. For elevations above 2,000 feet, rated capacity should be reduced by 4% for each 1,000 feet above sea level.
3. Based on 2500 BTU/Ft.<sup>3</sup>.
4. The air flow must be adequate to obtain a temperature rise within the range shown. Continuous return air temperature should not be below 55° F.

## SECTION V: AIRFLOW PERFORMANCE

**Table 12:** Airflow Performance - Side Duct Application

Model	Motor Speed	External Static Pressure (Inches WC)								
		0.1	0.2	0.3	0.4	0.5	0.6	0.7	0.8	1.0
		SCFM	SCFM	SCFM	SCFM	SCFM	SCFM	SCFM	SCFM	SCFM
36050	Low (1)	1003	952	904	851	790	730	674	633	551
	Low/Medium (2)	1180	1133	1085	1042	995	942	889	834	724
	Medium (3)	1259	1209	1166	1126	1084	1032	980	928	824
	Medium/High (4)	1314	1271	1229	1186	1144	1097	1049	998	896
	High (5)	1506	1471	1403	1389	1345	1305	1262	1216	1124
36075	Low (1)	1225	1174	1131	1090	1046	993	941	888	782
	Low/Medium (2)	1259	1209	1166	1126	1084	1032	980	928	824
	Medium (3)	1314	1271	1229	1186	1144	1097	1049	998	896
	Medium/High (4)	1348	1306	1259	1222	1179	1133	1086	1036	936
	High (5)	1506	1471	1403	1389	1345	1305	1262	1216	1124
36100	Low (1)	1342	1302	1260	1217	1178	1134	1082	1034	938
	Low/Medium (2)	1425	1368	1332	1293	1251	1208	1163	1113	1013
	Medium (3)	1554	1503	1465	1423	1386	1346	1302	1257	1167
	Medium/High (4)	1658	1599	1588	1530	1495	1454	1414	1373	1291
	High (5)	1966	1914	1862	1810	1757	1705	1653	1600	1496
42075	Low (1)	1315	1266	1229	1194	1156	1117	1080	1036	948
	Low/Medium (2)	1436	1382	1342	1304	1262	1220	1179	1131	1035
	Medium (3)	1458	1406	1365	1327	1286	1244	1203	1155	1059
	Medium/High (4)	1573	1523	1484	1445	1408	1367	1327	1279	1183
	High (5)	1966	1914	1862	1810	1757	1705	1653	1600	1496
42100	Low (1)	1436	1382	1342	1304	1262	1220	1179	1131	1035
	Low/Medium (2)	1544	1492	1455	1416	1376	1336	1294	1248	1156
	Medium (3)	1573	1523	1484	1445	1408	1367	1327	1279	1183
	Medium/High (4)	1681	1640	1599	1557	1517	1478	1436	1393	1307
	High (5)	1935	1887	1834	1788	1743	1701	1651	1591	1471
48065	Low (1)	1046	1009	980	946	915	878	844	779	649
	Low/Medium (2)	1295	1250	1213	1172	1133	1087	1045	964	802
	Medium (3)	1620	1564	1517	1466	1418	1360	1308	1206	1002
	Medium/High (4)	1798	1722	1669	1620	1572	1527	1480	1413	1280
	High (5)	2146	2085	2025	1960	1872	1862	1798	1735	1609
48100	Low (1)	1620	1564	1517	1466	1418	1360	1308	1206	1002
	Low/Medium (2)	1694	1630	1580	1530	1482	1430	1380	1292	1116
	Medium (3)	1798	1722	1669	1620	1572	1527	1480	1413	1280
	Medium/High (4)	1835	1758	1703	1653	1604	1558	1511	1442	1304
	High (5)	2146	2085	2025	1960	1872	1862	1798	1735	1609

Continued on next page.

**Table 12: Airflow Performance - Side Duct Application (Continued)**

Model	Motor Speed	External Static Pressure (Inches WC)								
		0.1	0.2	0.3	0.4	0.5	0.6	0.7	0.8	1.0
		SCFM	SCFM	SCFM	SCFM	SCFM	SCFM	SCFM	SCFM	SCFM
48125	Low (1)	1620	1564	1517	1466	1418	1360	1308	1206	1002
	Low/Medium (2)	1798	1722	1669	1620	1572	1527	1480	1413	1280
	Medium (3)	1922	1863	1804	1754	1724	1658	1612	1559	1453
	Medium/High (4)	2001	1952	1890	1839	1820	1742	1696	1651	1561
	High (5)	2146	2085	2025	1960	1872	1862	1798	1735	1609
60065	Low (1)	1073	1043	1009	988	963	941	917	892	842
	Low/Medium (2)	1329	1292	1250	1223	1192	1165	1136	1105	1043
	Medium (3)	2054	1998	1934	1890	1843	1801	1757	1710	1616
	Medium/High (4)	2195	2144	2098	2049	2003	1955	1883	1868	1838
	High (5)	2445	2388	2306	2293	2235	2178	2129	2077	1973
60100	Low (1)	1730	1682	1628	1592	1552	1517	1479	1439	1359
	Low/Medium (2)	1858	1807	1749	1710	1667	1629	1589	1546	1460
	Medium (3)	2054	1998	1934	1890	1843	1801	1757	1710	1616
	Medium/High (4)	2195	2144	2098	2049	2003	1955	1883	1868	1838
	High (5)	2445	2388	2306	2293	2235	2178	2129	2077	1973
60125	Low (1)	2063	2008	1943	1899	1851	1809	1763	1717	1625
	Low/Medium (2)	2130	2084	2032	1983	1927	1951	1860	1815	1725
	Medium (3)	2195	2144	2098	2049	2003	1955	1883	1868	1838
	Medium/High (4)	2275	2252	2169	2154	2112	2065	1989	1976	1950
	High (5)	2445	2388	2306	2293	2235	2178	2129	2077	1973

1. Airflow tested with dry coil conditions, without air filters, at 230 volts
2. Applications above 0.8" w.c. external static pressure are not recommended.
3. Brushless DC high efficiency standard ECM blower motor used for all indoor blower assemblies.
4. Minimal variations in airflow performance data results from operating at 208 volts. Data above may be used in those cases.
5. Heating applications tested at 0.50" w.c. esp, and cooling applications tested at 0.30" w.c. esp per standards.

**Table 13: Airflow Performance - Bottom Duct Application**

Model	Motor Speed	External Static Pressure (Inches WC)								
		0.1	0.2	0.3	0.4	0.5	0.6	0.7	0.8	1.0
		SCFM	SCFM	SCFM	SCFM	SCFM	SCFM	SCFM	SCFM	SCFM
36050	Low (1)	1008	962	916	861	807	757	700	650	550
	Low/Medium (2)	1190	1148	1106	1055	1008	955	914	863	761
	Medium (3)	1262	1223	1181	1137	1091	1044	994	952	868
	Medium/High (4)	1324	1282	1245	1202	1161	1112	1067	1018	920
	High (5)	1517	1475	1447	1400	1357	1318	1275	1232	1146
36075	Low (1)	1231	1186	1146	1103	1069	1030	977	912	781
	Low/Medium (2)	1270	1225	1189	1140	1098	1046	1008	960	866
	Medium (3)	1317	1286	1245	1198	1151	1110	1064	1024	943
	Medium/High (4)	1358	1317	1275	1238	1197	1148	1105	1057	961
	High (5)	1517	1475	1447	1400	1357	1318	1275	1232	1146
36100	Low (1)	1340	1299	1264	1224	1182	1182	1097	1049	953
	Low/Medium (2)	1409	1368	1334	1291	1253	1201	1173	1128	1038
	Medium (3)	1527	1492	1470	1419	1385	1343	1299	1250	1152
	Medium/High (4)	1663	1585	1594	1601	1521	1480	1440	1400	1320
	High (5)	1930	1892	1853	1805	1760	1696	1625	1553	1409
42075	Low (1)	1332	1295	1263	1222	1185	1148	1110	1063	967
	Low/Medium (2)	1457	1419	1376	1340	1299	1253	1215	1160	1051
	Medium (3)	1451	1412	1371	1339	1296	1257	1211	1165	1072
	Medium/High (4)	1568	1524	1491	1464	1425	1383	1345	1296	1200
	High (5)	1978	1937	1891	1837	1785	1725	1656	1604	1502
42100	Low (1)	1455	1414	1379	1335	1294	1254	1212	1160	1056
	Low/Medium (2)	1566	1532	1492	1455	1416	1372	1333	1280	1174
	Medium (3)	1565	1530	1491	1458	1419	1381	1336	1290	1198
	Medium/High (4)	1675	1641	1606	1578	1535	1495	1455	1412	1326
	High (5)	1946	1909	1863	1815	1771	1721	1654	1595	1477

Continued on next page.

**Table 13: Airflow Performance - Bottom Duct Application (Continued)**

Model	Motor Speed	External Static Pressure (Inches WC)								
		0.1	0.2	0.3	0.4	0.5	0.6	0.7	0.8	1.0
		SCFM	SCFM	SCFM	SCFM	SCFM	SCFM	SCFM	SCFM	SCFM
48065	Low (1)	1032	999	970	938	910	879	843	808	737
	Low/Medium (2)	1272	1236	1204	1165	1129	1081	1037	968	829
	Medium (3)	1611	1574	1518	1494	1439	1405	1357	1266	1083
	Medium/High (4)	1892	1777	1771	1701	1639	1617	1565	1489	1336
	High (5)	2131	2058	1998	1949	1892	1840	1788	1728	1608
48100	Low (1)	1598	1548	1502	1454	1410	1362	1307	1251	1139
	Low/Medium (2)	1663	1612	1568	1522	1476	1422	1370	1297	1152
	Medium (3)	1789	1733	1670	1650	1596	1578	1535	1483	1379
	Medium/High (4)	1931	1814	1808	1736	1673	1650	1597	1519	1362
	High (5)	2131	2058	1998	1949	1892	1840	1788	1728	1608
48125	Low (1)	1598	1548	1502	1454	1410	1362	1307	1251	1139
	Low/Medium (2)	1766	1703	1656	1611	1566	1518	1469	1419	1319
	Medium (3)	1912	1875	1805	1787	1750	1713	1672	1636	1564
	Medium/High (4)	2105	2014	2006	1931	1898	1845	1793	1739	1631
	High (5)	2131	2058	1998	1949	1892	1840	1788	1728	1608
60065	Low (1)	1026	999	989	950	907	907	886	862	816
	Low/Medium (2)	1263	1230	1192	1165	1167	1101	1099	1071	1015
	Medium (3)	1987	1933	1861	1817	1820	1715	1725	1651	1504
	Medium/High (4)	2114	2050	2047	1974	1899	1889	1920	1866	1758
	High (5)	2369	2308	2249	2183	2126	2088	2034	1990	1902
60100	Low (1)	1655	1612	1596	1531	1461	1462	1429	1391	1316
	Low/Medium (2)	1766	1720	1667	1629	1632	1539	1537	1498	1421
	Medium (3)	1987	1933	1861	1817	1820	1715	1725	1651	1504
	Medium/High (4)	2114	2050	2047	1974	1899	1889	1920	1866	1758
	High (5)	2369	2308	2249	2183	2126	2088	2034	1990	1902
60125	Low (1)	1973	1924	1905	1826	1743	1744	1703	1660	1574
	Low/Medium (2)	2024	1983	1937	1889	1886	1843	1799	1759	1679
	Medium (3)	2123	2075	2019	1970	1978	1862	1849	1804	1714
	Medium/High (4)	2191	2154	2117	2075	2002	1995	2028	1974	1866
	High (5)	2369	2308	2249	2183	2126	2088	2034	1990	1902

1. Airflow tested with dry coil conditions, without air filters, at 230 volts
2. Applications above 0.8" w.c. external static pressure are not recommended.
3. Brushless DC high efficiency standard ECM blower motor used for all indoor blower assemblies.
4. Minimal variations in airflow performance data results from operating at 208 volts. Data above may be used in those cases.
5. Heating applications tested at 0.50" w.c. esp, and cooling applications tested at 0.30" w.c. esp per standards.

## SECTION VI: OPERATION

**Table 14:** Additional Static Resistance

Size (Tons)	CFM	Wet Indoor Coil	Economizer <sup>1</sup>	Filter/Frame Kit
A36 (3.0)	700	0.01	0.00	0.04
	800	0.02	0.01	0.06
	900	0.03	0.01	0.08
	1000	0.04	0.01	0.10
	1100	0.05	0.01	0.13
	1200	0.06	0.02	0.16
	1300	0.07	0.03	0.17
	1400	0.08	0.04	0.18
A42 (3.5)	1100	0.02	0.02	0.04
	1200	0.03	0.02	0.04
	1300	0.04	0.02	0.05
	1400	0.05	0.03	0.05
	1500	0.06	0.04	0.06
	1600	0.07	0.04	0.07
	1700	0.07	0.04	0.08
	1800	0.08	0.04	0.09
	1900	0.09	0.05	0.10
	2000	0.09	0.05	0.11
B48 (4.0)	1100	0.02	0.02	0.04
	1200	0.03	0.02	0.04
	1300	0.04	0.02	0.05
	1400	0.05	0.03	0.05
	1500	0.06	0.04	0.06
	1600	0.07	0.04	0.07
	1700	0.07	0.04	0.08
	1800	0.08	0.04	0.09
	1900	0.09	0.05	0.10
	2000	0.09	0.05	0.11
B60 (5.0)	1100	0.02	0.02	0.04
	1200	0.03	0.02	0.04
	1300	0.04	0.02	0.05
	1400	0.05	0.03	0.05
	1500	0.06	0.04	0.06
	1600	0.07	0.04	0.07
	1700	0.07	0.04	0.08
	1800	0.08	0.04	0.09
	1900	0.09	0.05	0.10
	2000	0.09	0.05	0.11

1. The pressure drop through the economizer is greater for 100% outdoor air than for 100% return air. If the resistance of the return air duct is less than 0.25 IWG, the unit will deliver less CFM during full economizer operation. Filter pressure drop based on standard filter media tested at velocities not to exceed 300 ft/min.

The unit is controlled by a conventional heating/cooling thermostat. If an electronic thermostat is used, make sure it has a common connection. DO NOT use a power stealing thermostat.

## HEATING SEQUENCE OF OPERATION

**Heating**

The control board begins a call for heat when W is energized (connected to R).

The control checks to see if the pressure switch is open. If the pressure switch is closed, the control board flashes "2" on the LED and waits indefinitely for it to open. When the pressure switch is sensed as open, the control begins pressure switch proving period. If the call for heat is removed, the control goes back to Standby.

**Pressure Switch Proving**

The control board energizes the induced draft motor and waits for the pressure switch to close. When the pressure switch closes, the control begins Pre-purge period. If the call for heat is removed, the control de-energizes the inducer without post-purge and returns to standby.

If the pressure switch does not close within 5 seconds of inducer energizing, the control board flashes "3" on the LED. If the pressure switch does not close within 60 seconds of inducer energizing, the control shuts off the inducer for 60 seconds, then energizes the inducer for another 60 seconds in an attempt to close the pressure switch. This cycle continues indefinitely until either the pressure switch is proved closed, or the call for heat ends.

**Pre-purge**

The control board monitors the pressure switch and ensures it remains closed during pre-purge. If the pressure switch opens, the control goes back to pressure switch proving mode. The control waits for a 15 second pre-purge period, then begins the ignition trial.

**Ignition Trial Period**

The control board energizes the gas valve and spark outputs for a 5 second Ignition trial. The control de-energizes the spark when flame is sensed and enters a flame stabilization period.

If flame is not established within the ignition trial period, the control de-energizes the spark and gas valve and begins an inter-purge period before attempting another ignition trial.

If the call for heat is removed during an ignition trial period, the control immediately de-energizes spark and gas. The control runs the inducer motor through a post purge period before de-energizing.

If the pressure switch opens during an ignition trial period, the control immediately de-energizes spark and gas. The control begins pressure switch proving before an inter-purge and reignition attempt.

**Heat Blower On Delay**

The control board waits for 30 seconds and then energizes the indoor blower heat speed. Blower on delay time begins at the start of flame proving period in the trial for ignition.

If the thermostat demand for heat is removed, the control de-energizes the gas valve, energizes the blower on heat speed and initiates a post purge and heat blower off delay.

**Main Burner Operation**

The control board keeps the main gas valve and induced draft motor energized while continuously monitoring the call for heat, pressure switch, and flame status.

If the call for heat (W) is removed, the control de-energizes the gas valve, begins post purge and heat blower off delay.

If the pressure switch opens, the control de-energizes the gas valve and begins pressure switch proving mode.

If flame is removed, the control de-energizes the gas valve within 2.0 seconds and counts the flame loss. If flame has been lost less than 5 times, the control attempts re-ignition after a 15 second inter-purge period. If flame has been lost more than 5 times within the same call for heat, the control board locks out flashing "8" on the LED. Post Purge

The control board runs the induced draft motor for a 15 second post-purge period, and then de-energizes the inducer. If a call for heat occurs during post-purge, the control finishes the post-purge, and immediately begins the next ignition sequence.

**Heat Blower Off Delay**

After a heating sequence the control board de-energizes the indoor blower motor after a delay time as selected by a movable shunt (60, 90, 120 or 180 seconds). Blower off timing begins when the thermostat is satisfied and removes (W) the call for heat. The control returns to standby when the blower off delay is complete.

If the thermostat call for heat returns before the blower off delay is complete, the control begins an ignition sequence with prepurge while the blower off delay continues.

## Lockout

While in lockout, the control board keeps the main gas valve and induced draft motor de-energized.

Lockouts due to failed ignition or flame losses may be reset by removing the call for heat (W) for more than 1 second, or by removing power from the control for over 0.25 seconds. The control will automatically reset lockout after 60 minutes.

Lockouts due to detected internal control faults will reset after 60 minutes or power interruption. Cooling operations are available during a heating lockout.

## High Temperature Limit Switch

Any time the high temperature limit switch is open less than 5 minutes the control board will run the indoor blower motor on heat speed, run the inducer, de-energize the gas valve, and flash "4" on the LED. When the high temperature switch closes, the control will restart the ignition sequence beginning with pre-purge.

If the limit switch has been open more than 5 minutes the control will de-energize the inducer, continue to operate the indoor blower motor on heat speed, and flash "11" on the LED

## Rollout Switch

If the limit circuit is open for more than 15 minutes, the control board will flash "5" on the LED. The blower output will be energized during an open rollout condition.

If the rollout switch is reset, the control shall remain locked out until power is removed or a call for heat (W) is removed.

Rollout switch lockout shall not reset automatically.

## Power Interruptions

Power interruptions of any duration shall not cause lockout or any operation requiring manual intervention.

## Flame present with Gas off

If flame is sensed for longer than 4.0 seconds during a period when the gas valve should be closed, the control will enter lockout flashing "1" on the LED. The control will energize the inducer blower while the flame is sensed.

## GAS VALVE FAULT

If the main valve output is sensed to be energized for more than 1 second when commanded to be off, the control de-energizes the induced draft motor (if flame is not present) to attempt to open the pressure switch to de-energize the gas valve. If the main gas valve is still sensed as energized after the inducer has been off for 10 seconds, the control re-energizes the inducer to vent the unburned gas. The control enters a hard lockout flashing "10" on the LED.

The only way to recover from a hard lockout is to remove and reapply 24VAC power to the control board.

## Safety Controls

The control circuit includes the following safety controls:

1. Limit Switch (LS) - This control is located inside the blower compartment and protrudes into the heat exchanger compartment and is set to open at the temperature indicated in the Temperature Controls Table of the unit wiring diagram. It resets automatically. The limit switch operates when a high temperature condition occurs, thus shutting down the ignition control, closes the main gas valve and energizes the blower.
2. Pressure Switch (PS) - If the draft motor should fail, the pressure switch prevents the ignition control and gas valve from being energized.
3. Flame Sensor - The flame sensor is located on the left-most burner. If an ignition control fails to detect a signal from the flame sensor indicating the flame is properly ignited, then the main gas valve will close.
4. Rollout Switch (RS) - This switch is located on the burner assembly. In the event of a sustained main burner flame rollout, the control will close the main gas valve. This is a manual reset type switch.

## NOTICE

*The manual reset Rollout Switch (RS) must be reset before allowing furnace operation.*

**Table 15:** Ignition Control Board Flash Codes

Flash Code	Description
<b>Normal Operation</b>	
Green Heartbeat	Standby mode
Amber Heartbeat	Call for furnace heat active
<b>Operational Faults</b>	
Steady ON (any color)	Control failure
Rapid Amber Flash	Low flame current <1.5 VDC at test pad
1 Red Flash	Flame sensed with gas valve off
2 Red Flashes	Pressure switch closed with inducer off
3 Red Flashes	Pressure switch open with inducer on
4 Red Flashes	Limit switch or rollout switch open
5 Red Flashes	Limit switch or rollout switch open >15 minutes
6 Red Flashes	Pressure switch cycle lockout
7 Red Flashes	Lockout due to failed ignition
8 Red Flashes	Lockout due to too many flame dropouts
10 Red Flashes	Gas valve fault
11 Red Flashes	Limit/Rollout switch open between 5 and 15 minutes
<b>Wiring Related Faults</b>	
9 Red Flashes	Incorrect low voltage polarity
4 Amber Flashes	Y thermostat demand without a G

## COOLING SEQUENCE OF OPERATIONS

When the thermostat calls for COOL, the thermostat terminals G and Y are energized, which signals the compressor, outdoor fan and indoor blower to run.

With a call for Y, the circulating fan is energized at cooling speed.

When the thermostat is satisfied, terminals G and Y are de-energized, de-energizing the compressor and outdoor fan.

After a cool fan off delay timing of 30 seconds, the circulating fan is de-energized.

## Safety Controls

The control circuit includes the following safety controls:

High Pressure Switch (HP) - This switch protects against excessive discharge pressures due to a blocked condenser coil or a condenser motor failure (opens at  $650 \pm 25$  psig and closes at  $450 \pm 25$  psig).

The above pressure switches are specifically designed to operate with R-410A systems. R-22 pressure switches must not be used as replacements for the R-410A pressure switches.

## ⚠ WARNING

*The ability to properly perform maintenance on this equipment requires certain expertise, mechanical skills, tools and equipment. If you do not possess these, do not attempt to perform any maintenance other than those procedures recommended in this Installation Manual. Failure to heed this warning could result in serious injury and possible damage to this equipment.*

## Circulating Fan

When the thermostat calls for FAN, the thermostat terminal G is energized signaling the circulating fan to run at the G-Speed airflow.

If a call for COOL occurs (Y), the circulating fan switches to run at the Y-Speed airflow.

If a call for HEAT occurs (W), the circulating fan switches to W-Speed after a 30 second delay.

When the thermostat ends the call for FAN, the thermostat terminal G is de-energized, de-energizing the circulating fan.

## START-UP

### Prestart Check List

Complete the following checks before starting the unit.

1. Check the type of gas being supplied. Be sure that it is the same as listed on the unit nameplate.
2. Make sure that the vent outlet air hood and air intake hood has been properly installed.

### Operating Instructions

1. STOP! Read the information on the unit safety label.
2. Set the thermostat to the OFF position.
3. Turn off all electrical power to the unit.
4. DO NOT try to light the burners by hand. This appliance is equipped with an ignition device which automatically lights the burners.
5. Remove the access panel.
6. Turn the gas valve switch to the OFF position.
7. Wait five (5) minutes to clear out any gas. If you then smell gas, STOP! Follow B in the information on the unit safety label. If you don't smell gas, go to the next step.
8. Turn the gas valve switch to the ON position.
9. Replace the control access panel.
10. Turn on all electric power to the unit.
11. Set the thermostat to the desired setting.
12. If the unit will not operate, follow the instructions To Turn Off Gas To Appliance and call your service technician or gas supplier.

### To Turn Off Gas To Unit

1. Set the thermostat to the OFF position.
2. Turn off all electric power to the appliance if service is to be performed.
3. Remove the control access panel.
4. Turn the gas valve switch to the OFF position. DO NOT FORCE.
5. Replace the control access panel.

### Post Start Check List

After the entire control circuit has been energized and the heating section is operating, make the following checks:

1. Check for gas leaks in the unit piping as well as the supply piping.
2. Check for correct manifold gas pressures. See Checking Gas Input.
3. Check the supply gas pressure. It must be within the limits shown on rating nameplate. Supply pressure should be checked with all gas appliances in the building at full fire. At no time should the standby gas line pressure exceed 13.5", nor the operating pressure drop below 4.5" for natural gas units. If gas pressure is outside these limits, contact the local gas utility for corrective action.

### Compressor Rotation

## ▲ CAUTION

Scroll compressors require proper rotation to operate properly. Failure to check and correct rotation may result in property damage.

Three-phase, scroll compressors operate in only one direction. If the scroll is drawing low amperage, has similar suction and discharge pressures, or is producing a high noise level, the scroll is misphased. Change the incoming line connection phasing to obtain the proper rotation.

## ADJUSTMENT OF MANIFOLD GAS PRESSURE & INPUT RATE

Inlet and manifold gas pressure may be measured by connecting the "U" tube manometer to the gas valve with a piece of tubing. Follow the appropriate section in the instructions below. Refer to Figure 9 for the locations of the pressure ports on the gas valve.

### Turn gas off at the ball valve or gas cock on gas supply line before the gas valve. Find the pressure ports on the gas valve marked Out P and In P.

1. The manifold pressure must be taken at the port marked OUT P.
2. The gas line pressure must be taken at the port marked IN P.
3. Using a 3/32" (2.4 mm) hex head wrench, loosen the set screw by turning it 1 turn counter clockwise. DO NOT REMOVE THE SET SCREW FROM THE PRESSURE PORT.

### Read the inlet gas pressure

Connect the positive side of the manometer to the IN P Tap on the gas valve. Do not connect any tubing to the negative side of the manometer, as it will reference atmospheric pressure. Refer to Figures 9 and 10 for connection details.

1. Turn gas and electrical supplies on and follow the operating instructions to place the unit back in operation.

**Table 16:** Inlet Gas Pressure Range

INLET GAS PRESSURE RANGE		
	Natural Gas	Propane (LP)
Minimum	4.5" w.c. (1.12 kPa)	8.0" w.c. (1.99 kPa)
Maximum	10.5" w.c. (2.61 kPa)	13.0" w.c. (3.24 kPa)

## IMPORTANT

*The inlet gas pressure operating range table specifies what the minimum and maximum gas line pressures must be for the furnace to operate safely. The gas line pressure **MUST BE** a minimum of:*

- 7" w.c. (1.74 kPa) for Natural Gas
- 11" w.c. (2.74 kPa) for Propane (LP) Gas

*in order to obtain the BTU input specified on the rating plate and/or the nominal manifold pressure specified in these instructions and on the rating plate.*

2. Once the correct gas inlet pressure has been established, see Table 16, turn the gas valve to OFF and turn the electrical supply switch to OFF; then remove the flexible tubing from the gas valve pressure tap and tighten the pressure tap plug using the 3/32" (2.4 mm) hex head wrench.
3. Turn the electrical and gas supplies back on, and with the burners in operation, check for gas leakage around the gas valve pressure port for leakage using an approved non-corrosive gas leak detection fluid, or other non-flammable leak detection methods.

## Read the manifold gas pressure

Connect the positive side of the manometer to the OUT P Tap on the gas valve. Do not connect any tubing to the negative side of the manometer, as it will reference atmospheric pressure. Refer to Figures 9 and 10 for connection details.

## IMPORTANT

*The cap for the pressure regulator must be removed entirely to gain access to the adjustment screw. Loosening or tightening the cap does not adjust the flow of gas.*

## NOTICE

*The regulated outlet pressure has been calibrated at the factory. Additional pressure adjustment should not be necessary. If adjustment is necessary, set to the following specifications. After adjustment, check for gas leakage.*

1. Refer to Figure 9 for location of pressure regulator adjustment cap and adjustment screws on main gas valve.
2. Turn gas and electrical supplies on and follow the operating instructions to place the unit back in operation.
3. Adjust manifold pressure by adjusting gas valve regulator screw for the appropriate gas per Table 17.

**Table 17:** Nominal Manifold Pressure

NOMINAL MANIFOLD PRESSURE	
Natural Gas	3.5" w.c. (0.87 kPa)
Propane (LP) Gas	10.0" w.c. (2.488 kPa)

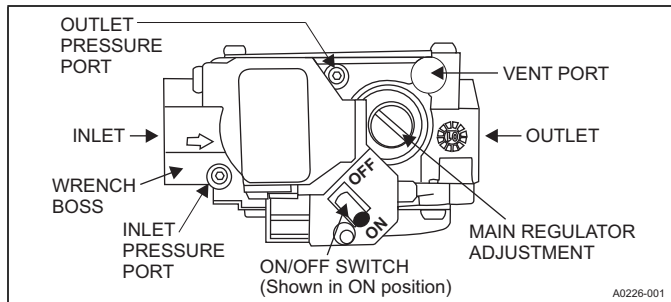

**FIGURE 9:** Gas Valve

## IMPORTANT

*If gas valve regulator is turned in (clockwise), manifold pressure is increased. If screw is turned out (counterclockwise), manifold pressure will decrease.*

4. After the manifold pressure has been adjusted, re-calculate the furnace input to make sure you have not exceeded the specified input on the rating plate. Refer to "CALCULATING THE FURNACE INPUT (NATURAL GAS)".

5. Once the correct BTU (kW) input has been established, turn the gas valve to OFF and turn the electrical supply switch to OFF; then remove the flexible tubing from the gas valve pressure tap and tighten the pressure tap plug using the 3/32" (2.4 mm) hex head wrench.
6. Turn the electrical and gas supplies back on, and with the burners in operation, check for gas leakage around the gas valve pressure port for leakage using an approved non-corrosive gas leak detection fluid, or other non-flammable leak detection methods.

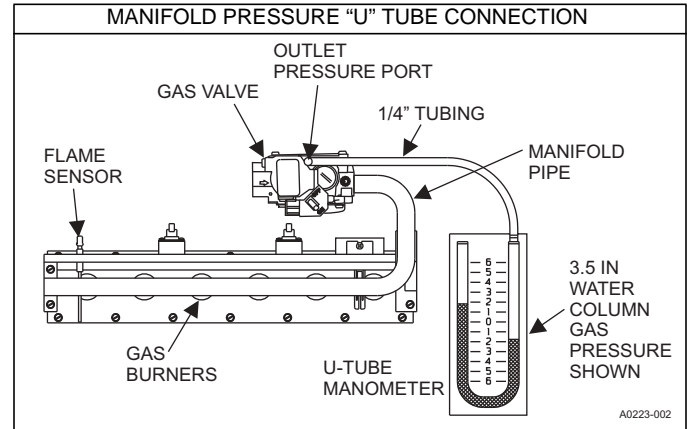

**FIGURE 10:** Reading Gas Pressure

## ADJUSTMENT OF TEMPERATURE RISE

### ⚠ DANGER

*The temperature rise, or temperature difference between the return air and the supply (heated) air from the furnace, must be within the range shown on the furnace rating plate and within the application limitations shown in Table 6.*

*The supply air temperature cannot exceed the "Maximum Supply Air Temperature" specified in these instructions and on the furnace rating plate. Under NO circumstances can the furnace be allowed to operate above the Maximum Supply Air Temperature. Operating the furnace above the Maximum Supply Air Temperature will cause premature heat exchanger failure, high levels of Carbon Monoxide, a fire hazard, personal injury, property damage, and/or death.*

After about 5 minutes of operation, determine the furnace temperature rise. Take readings of both the return air and the heated air in the ducts, about six feet (1.8 m) from the furnace where they will not be affected by radiant heat. Increase the blower speed to decrease the temperature rise; decrease the blower speed to increase the rise.

## DIRECT DRIVE BLOWER

All units have direct drive, multi speed standard ECM blower motors.

Connect manometer per "EXTERNAL STATIC PRESSURE SECTION". Place unit in cooling mode and adjust blower speed accordingly per Table 12 or 13.

## EXTERNAL STATIC PRESSURE SETUP

To measure external static pressure:

- Measure the supply air static pressure
- Record this positive number
- Measure the return air static pressure

- Record this negative number
- Treat the negative number as a positive and add the two numbers together
- This is total system static

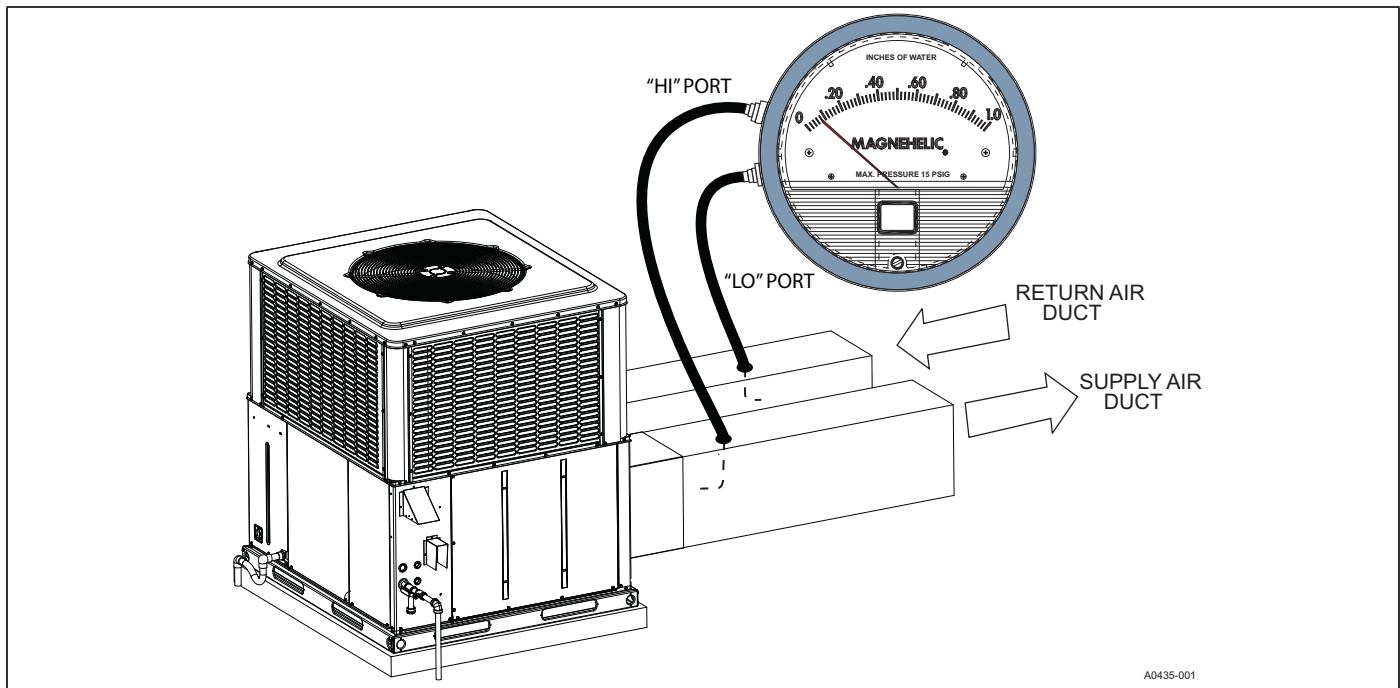

**FIGURE 11:** Measuring External Static Pressure

## CHECKING GAS HEAT INPUT

## Natural Gas

1. Turn off all other gas appliances connected to the gas meter.
2. With the unit turned on, measure the time needed for one revolution of the hand on the smallest dial on the meter. A typical gas meter usually has a 1/2 or a 1 cubic foot test dial.
3. Using the number of seconds for each revolution and the size of the test dial increment, find the cubic feet of gas consumed per hour from Table 18.

If the actual input is not within 5% of the unit heating rating with allowance being made for the permissible range of the regulator setting, replace the orifice spuds with spuds of the proper size.

## NOTICE

*To find the BTU input, multiply the number of cubic feet of gas consumed per hour by the BTU content of the gas in your particular locality. (Contact your gas company for this information since it varies widely from city to city.)*

**Table 18:** Gas Rate Cubic Feet Per Hour<sup>1</sup>

Seconds for One Rev.	Size of Test Dial	
	1/2 cu. ft.	1 cu. ft.
10	180	360
12	150	300
14	129	257
16	113	225
18	100	200
20	90	180
22	82	164
24	75	150
26	69	138
28	64	129
30	60	120
32	56	113
34	53	106
36	50	100
38	47	95
40	45	90
42	43	86
44	41	82
46	39	78
48	37	75
50	36	72
52	35	69
54	34	67
56	32	64
58	31	62
60	30	60

1. **EXAMPLE:** By actual measurement, it takes 38 seconds for the hand on the 1-cubic foot dial to make a revolution with just a 100,000 BTUH furnace running. Using this information, locate 38 seconds in the first column of Table 18. Read across to the column headed "1 Cubic Foot," where you will see that 95 cubic feet of gas per hour are consumed by the furnace at that rate. Multiply 95 x 1050 (the BTU rating of the gas obtained from the local gas company). The result is 99,750 BTUH, which is close to the 100,000 BTUH rating of the unit.



**CAUTION - OPEN ALL DISCONNECTS BEFORE SERVICING THIS UNIT**

**DSI Fault Codes**

**Normal Operation**

- Green Heartbeat Standby mode
- Amber Heartbeat Call for furnace heat active
- Rapid Green Flashes Control in Factory Test mode

**Operational Fault Codes**

Flashes	Fault Condition
None	Power Off or open fuse
Slow Green Flashes	Normal Operation
Slow Amber Flashes	Normal Operation with call for heat
Rapid Amber Flashes	Low flame sense current
4 Amber Flashes	No G from thermostat with Y call
Steady on Red	Control Failure
1 Red Flash	Flame present with gas off
2 Red Flashes	Check pressure switch wiring
3 Red Flashes	Vent OR termination problem
4 Red Flashes	Airflow problem
5 Red Flashes	Flame Rollout
6 Red Flashes	Repeated pressure switch cycles
7 Red Flashes	Failed to light burners
8 Red Flashes	Loss of flame during call for heat
9 Red Flashes	Improper ground OR incorrect 24V phasing
10 Red Flashes	Gas valve shorted "ON"
11 Red Flashes	Check blower motor/wiring

CONTROL BOARD SETTINGS:  
 COMBUSTION BLOWER POST PURGE: 60 SEC  
 INDOOR BLOWER HEAT ON DELAY: 30 SEC  
 INDOOR BLOWER COOL OFF DELAY: 60 SEC  
 INDOOR BLOWER HEAT OFF DELAY: FIELD SELECT

— LINE VOLTAGE  
 - - - FIELD INSTALLED POWER  
 — LOW VOLTAGE  
 ..... FIELD INSTALLED CONTROL

**NOTICE**  
 THIS UNIT IS WIRED FOR THREE-PHASE POWER. DO NOT CONNECT TO A SINGLE-PHASE SUPPLY.

**LADDER WIRING DIAGRAM**

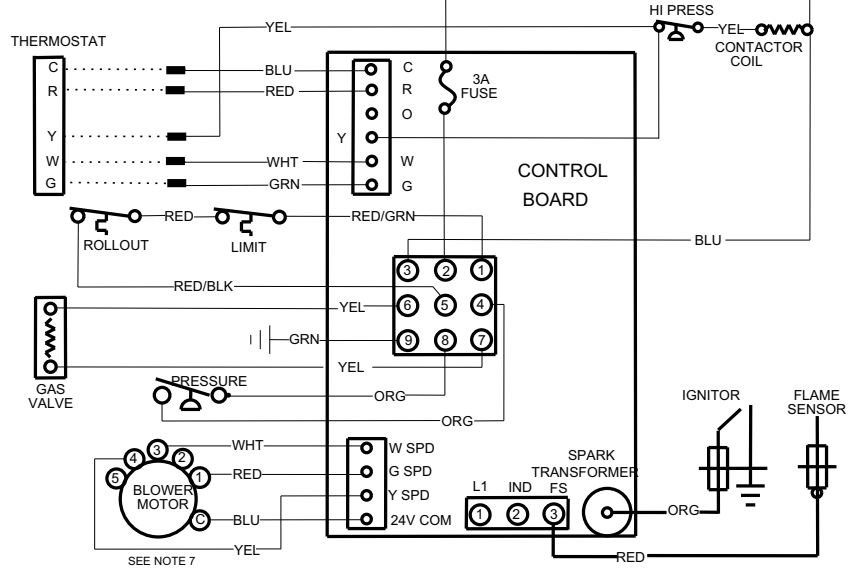
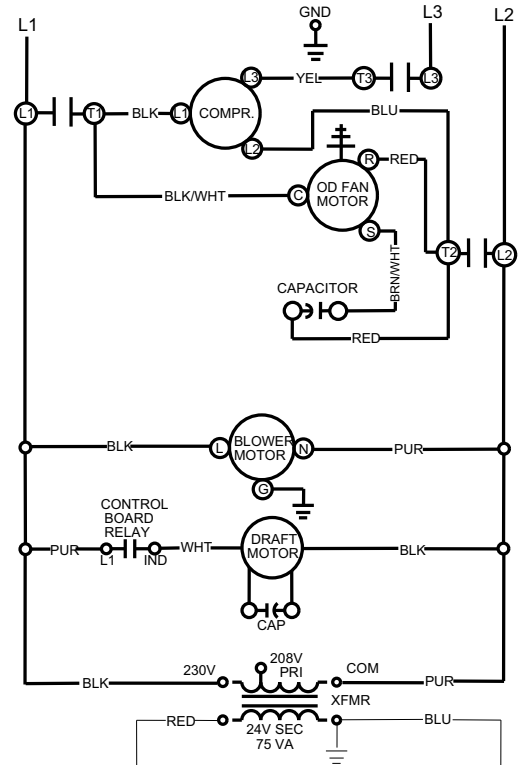

**NOTES:**

- ALL FIELD WIRING TO BE ACCOMPLISHED FOLLOWING CITY, LOCAL AND/OR NATIONAL CODES IN EFFECT AT THE TIME OF INSTALLATION OF THE UNIT.
- CAUTION - LABEL ALL WIRES PRIOR TO DISCONNECTION WHEN SERVICING CONTROLS. WIRING ERRORS CAN CAUSE IMPROPER AND DANGEROUS OPERATION. IF ANY OF THE WIRING, AS SUPPLIED WITH THE UNIT, MUST BE REMOVED, IT MUST BE REPLACED WITH TYPE 105 C. 600 VOLT WIRE OR EQUIVALENT CLEARLY RENUMBERED FOR IDENTIFICATION. VERIFY PROPER OPERATION AFTER SERVICING.
- FACTORY WIRED FOR 230 VOLT THREE PHASE SUPPLY POWER. FOR 208 VOLT, MOVE BLACK WIRES FROM THE 230 TO THE 208 VOLT TAP ON THE TRANSFORMER.
- MOTORS ARE INHERENTLY PROTECTED.
- SEE UNIT NAMEPLATE FOR MAXIMUM FUSE AND/OR CIRCUIT BREAKER SIZE AND MINIMUM CIRCUIT AMPACITY.
- SELECT INDOOR BLOWER SPEED TO REMAIN WITHIN THE TEMPERATURE RISE RANGE ON THE NAMEPLATE IN HEATING AND TO OBTAIN APPROX. 400 CFM/TON IN COOLING.
- BLOWER MOTOR SPEED CONNECTIONS SHOWN ARE TYPICAL, BUT MAY VARY BY MODEL AND APPLICATION.

**FIGURE 13: Ladder Wiring Diagram**

## R-410A QUICK REFERENCE GUIDE

### Refer to Installation Instructions for specific installation requirements

- R-410A refrigerant operates at 50 - 70 percent higher pressures than R-22. Be sure that servicing equipment and replacement components are designed to operate with R-410A.
- R-410A refrigerant cylinders are rose colored.
- Recovery cylinder service pressure rating must be 400 psig, DOT 4BA400, or DOT BW400.
- Recovery equipment must be rated for R-410A.
- **DO NOT** use R-410A service equipment on R-22 systems. All hoses, gages, recovery cylinders, charging cylinders and recovery equipment must be dedicated for use on R-410A systems only.
- Manifold sets must be at least 700 psig high side, and 180 psig low side, with 550 psig retard.
- All hoses must have a service pressure rating of 800 psig.
- Leak detectors must be designed to detect HFC refrigerants.
- Systems must be charged with liquid refrigerant. Use a commercial type metering device in the manifold hose.
- R-410A can only be used with POE type oils.
- POE type oils rapidly absorb moisture from the atmosphere.
- Vacuum pumps will **not** remove moisture from R-410A refrigerant oils.
- **Do not** use liquid line driers with a rated working pressure rating less than 600 psig.
- **Do not** install suction line driers in the liquid line.
- A liquid line drier is required on every unit.
- **Do not** use a R-22 TXV. If a TXV is to be used, it must be a R-410A TXV.
- Never open system to atmosphere when under a vacuum.
- If system must be opened for service, evacuate system then break the vacuum with dry nitrogen and replace all filter driers.

FIGURE 14: R-410A Quick Reference Guide

SECTION VIII: START UP SHEET

Residential Package Unit Cooling / Gas Heat Start-Up Sheet

Proper start-up is critical to customer comfort and equipment longevity

Print Form

Reset Form

Start-Up Date  Company Name  Start-Up Technician

**Owner Information**

Name  Address  Daytime Phone   
 City  State or Province  Zip or Postal Code

**Equipment Data**

Unit Model #  Unit Serial #

**General Information** (Check all that apply)

Residential  New Construction  Roof level  Down flow  
 Commercial  Retrofit  Grade level  Side flow

**Unit Location and Connections** (Check all that apply)

Unit is level and installed on:  Slab  Roof curb  Duct connections are complete:  Supply  Return  
 Condensate drain properly connected per the installation instructions  Condensate trap has been primed with water

**Filters**

Filters installed Number of filters  Filter size   Filter located inside  Filter located outside

**Additional Kits & Accessories Installed** (Check all that apply)

Refrigerant safety kit  Low ambient kit  Anti-recycle timer  Crank case heater  Filter frame kit  
 Transformer kit  Economizer  Roof curb kit  Base rail hole blockage kit   
 Manual fresh air damper kit  Motorized fresh air damper kit

**Electrical Connections & Inspection** (Check all that apply)

Single phase  Three phase  208 volts AC  230 volt AC  460 volts AC  575 volts AC  
 Inspect wires and electrical connections  Transformer wired properly for primary supply voltage  Ground connected  
 Low voltage present at control board "R & C" Measured voltage "R" and "C" outdoor unit control board   
 Line voltage present at disconnect Measured voltage "L1 to L2"  "L2 to L3"  "L1 to L3"   
 Compressor amperes "L1"  "L2"  "L3"  Total amperes "L1"  "L2"  "L3"   
 Single stage compressor  Two stage compressor

**Air Flow Setup / Cooling**

<b>Blower Type &amp; Set-Up</b>	<input type="radio"/> V.S. ECM	COOL <input type="radio"/> A <input type="radio"/> B <input type="radio"/> C <input type="radio"/> D
		ADJUST <input type="radio"/> A <input type="radio"/> B <input type="radio"/> C <input type="radio"/> D
		DELAY <input type="radio"/> A <input type="radio"/> B <input type="radio"/> C <input type="radio"/> D
	<input type="radio"/> ECM <input type="radio"/> 1 <input type="radio"/> 2 <input type="radio"/> 3 <input type="radio"/> 4 <input type="radio"/> 5	
<input type="radio"/> PSC <input type="radio"/> Low <input type="radio"/> Medium Low <input type="radio"/> Medium <input type="radio"/> Medium High <input type="radio"/> High		

Supply static (inches of water column)  Supply air dry bulb temperature  Outside air dry bulb temperature   
 Return static (inches of water column)  Return air dry bulb temperature  Return air wet bulb temperature   
 Total external static pressure  Temperature drop  Supply air wet bulb temperature

