

# INSTALLATION MANUAL

**SINGLE PACKAGE  
AIR CONDITIONER / ELECTRIC HEAT  
MODELS: PCE4 SERIES  
2 THRU 5 TONS – 208/230V - 1 PHASE**



## LIST OF SECTIONS

GENERAL INFORMATION .....	1	OPERATION .....	15
SAFETY .....	1	MAINTENANCE .....	16
MODEL NUMBER NOMENCLATURE .....	2	TYPICAL WIRING DIAGRAMS .....	17
INSTALLATION .....	2	START UP SHEET .....	23
AIRFLOW PERFORMANCE .....	13		

## LIST OF FIGURES

Component Location .....	3	Single Point Wiring Kits .....	11
Unit 4 Point Load Weight .....	4	Measuring External Static Pressure .....	16
Unit Dimensions .....	4	Connection Wiring Diagram - 2 to 3 Ton Models .....	17
Bottom Duct Dimensions (inches) .....	5	Ladder Wiring Diagram - 2 to 3 Ton Models .....	18
Rear Duct Dimensions (inches) .....	5	Connection Wiring Diagram - 3.5 to 5 Ton Models .....	19
Typical Field Control Wiring Diagram For Air Conditioner Models ...	6	Ladder Wiring Diagram - 3.5 to 5 Ton Models .....	20
Typical Field Power Wiring Diagram .....	6	R-410A Quick Reference Guide .....	21

## LIST OF TABLES

Unit Limitations .....	2	Physical Data .....	12
Weights and Dimensions .....	4	Airflow Performance - Side Duct Application .....	13
Unit Dimensions .....	4	Airflow Performance - Bottom Duct Application .....	14
Unit Clearances .....	5	Electric Heat Minimum Supply Air .....	14
Electrical Data - 208/230-1-60 Single Source Power .....	7	Electric Heat Multipliers .....	14
Electrical Data for 208-1-60 Multi Source Power .....	8	Additional Static Resistance .....	15
Electrical Data for 230-1-60 Multi Source Power .....	9	Thermostat Signals .....	15
Single-point Wiring Kits .....	11		

## SECTION I: GENERAL INFORMATION

PCE units are factory assembled air conditioners designed for outdoor installation on a roof top or a slab. Field-installed electric heater accessories are available to provide electric heat.

The units are completely assembled on rigid, removable base rails. All piping, refrigerant charge, and electrical wiring is factory installed and tested. The units require only electric power and duct connections at the point of installation.

## SECTION II: SAFETY



This is a safety alert symbol. When you see this symbol on labels or in manuals, be alert to the potential for personal injury.

Understand and pay particular attention to the signal words **DANGER**, **WARNING**, or **CAUTION**.

**DANGER** indicates an **imminently** hazardous situation, which, if not avoided, **will result in death or serious injury**.

**WARNING** indicates a **potentially** hazardous situation, which, if not avoided, **could result in death or serious injury**.

**CAUTION** indicates a potentially hazardous situation, which, if not avoided **may result in minor or moderate injury**. It is also used to alert against unsafe practices and hazards involving only property damage.

## WARNING

*Improper installation may create a condition where the operation of the product could cause personal injury or property damage. Improper installation, adjustment, alteration, service or maintenance can cause injury or property damage. **Failure to carefully read and follow all instructions in this manual can result in furnace malfunction, death, personal injury and/or property damage.** Only a qualified contractor, installer or service agency should install this product.*

## CAUTION

*This product must be installed in strict compliance with the installation instructions and any applicable local, state, and national codes including, but not limited to building, electrical, and mechanical codes.*

**⚠ WARNING**

Before performing service or maintenance operations on unit, turn off main power switch to unit. Electrical shock could cause personal injury. Improper installation, adjustment, alteration, service or maintenance can cause injury or property damage. Refer to this manual. For assistance or additional information consult a qualified installer, service agency or the gas supplier.

**⚠ CAUTION**

This system uses R-410A Refrigerant which operates at higher pressures than R-22. No other refrigerant may be used in this system. Gage sets, hoses, refrigerant containers and recovery systems must be designed to handle R-410A. If you are unsure, consult the equipment manufacturer. Failure to use R-410A compatible servicing equipment may result in property damage or injury.

Due to system pressure, moving parts, and electrical components, installation and servicing of air conditioning equipment can be hazardous. Only qualified, licensed service personnel should install, repair, or service this equipment. Unlicensed personnel can perform basic maintenance functions of cleaning coils and filters and replacing filters.

Observe all precautions in the literature, labels, and tags accompanying the equipment whenever working on air conditioning equipment. Be sure to follow all other applicable safety precautions and codes including.

Wear safety glasses and work gloves. Use quenching cloth and have a fire extinguisher available during brazing operations.

**INSPECTION**

As soon as a unit is received, it should be inspected for possible damage during transit. If damage is evident, the extent of the damage should be noted on the carrier's freight bill. A separate request for inspection by the carrier's agent should be made in writing.

**REPLACEMENT PARTS**

Contact your local Unitary Products parts distribution center for authorized replacement parts.

**SECTION III: MODEL NUMBER NOMENCLATURE**

PCE	4	A	24	50	2	X	1	A
1	2	3	4		6		8	9
<b>1. Model Family</b> PCE - packaged A/C with electric heat, PHE - packaged with electric heat, PCG - packaged A/C with gas heat, PHG - packaged with gas heat, <b>2. Nominal Cooling Efficiency</b> 4 = 14 SEER, 6 = 16 SEER, etc. <b>3. Cabinet Size</b> A = small 35 x 51, B = large 45 x 51 <b>4. Nominal Air Conditioning Cooling Capacity BTUx1000</b> 24 = 24,000 BTU, etc. <b>Examples:</b> PCE4B4221A is a packaged air conditioner, 14 SEER, 3-1/2 ton, large cabinet, 230 volt, single phase model, (first generation, first release)					<b>5. Gas Heating Input BTU/Hr x 1000</b> 050 = 50,000 BTU/Hr. input, blank = electric heat <b>6. Voltage-Phase-Frequency</b> 2 = 208/230-1-60, 3=208/230-3-60, 4 = 460-3-60 <b>7. NOx Approval</b> X = low-NOx, blank = not low-NOx <b>8. Generation Level</b> 1 = first generation <b>9. Revision Level</b> A = original release, B = second release			

**SECTION IV: INSTALLATION****LIMITATIONS**

These units must be installed in accordance with the following national and local safety codes.

- National Electrical Code ANSI/NFPA No. 70 or Canadian Electrical Code Part 1, C22.1 (latest editions).
- Local plumbing and waste water codes and other applicable local codes.

Refer to Table 9 for unit physical data and to Tables 5-7 for electrical data.

If components are to be added to a unit to meet local codes, they are to be installed at the dealer's and/or the customer's expense.

Size of unit for proposed installation should be based on heat loss/heat gain calculations made in accordance with industry recognized procedures such as the Air Conditioning Contractors of America (manual J).

**Table 1: Unit Limitations**

Model	Unit Voltage	Unit Limitations		
		Applied Voltage		Outdoor DB Temp
		Min	Max	Max (°F)
A24	208/230-1-60	187	252	125
A30	208/230-1-60	187	252	125
A36	208/230-1-60	187	252	125
A42	208/230-1-60	187	252	125
B48	208/230-1-60	187	252	125
B60	208/230-1-60	187	252	125

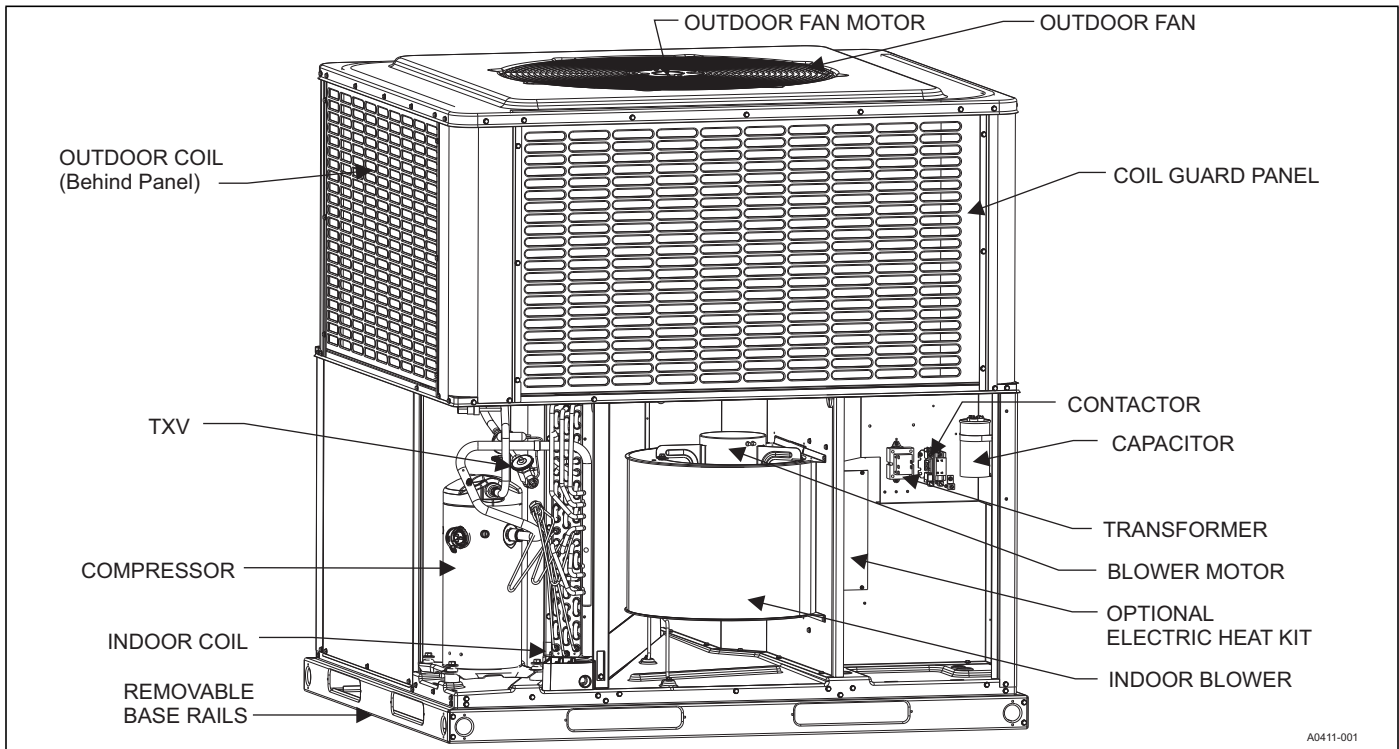

**FIGURE 1:** Component Location

#### LOCATION

Use the following guidelines to select a suitable location for these units:

### ⚠ WARNING

*Do not permit overhanging structures or shrubs to obstruct outdoor air discharge outlet.*

1. Unit is designed for **outdoor installation** only.
2. Outdoor coils must have an unlimited supply of air. Where a choice of location is possible, position the unit on either north or east side of building.
3. Suitable for mounting on roof curb.

### ⚠ WARNING

*Do not attach supply and return duct work to the bottom of the unit base pan as the drain pan could be compromised.*

4. For ground level installation, a level pad or slab should be used. The thickness and size of the pad or slab used should meet local codes and unit weight. Do not tie the slab to the building foundation.
5. Roof structures must be able to support the weight of the unit and its options/accessories. Unit must be installed on a solid, level roof curb or appropriate angle iron frame.
6. Maintain level tolerance to 1/8" across the entire width and length of unit.

#### CLEARANCES

All units require certain clearances for proper operation and service. Refer to Table 4 for the clearances required for construction, servicing and proper unit operation.

#### RIGGING AND HANDLING

### ⚠ CAUTION

*All panels must be secured in place when the unit is lifted. The outdoor coils should be protected from rigging cable damage with plywood or other suitable material.*

### ⚠ CAUTION

*If a unit is to be installed on a roof curb other than a Unitary Products roof curb, gasket or sealant must be applied to all surfaces that come in contact with the unit underside.*

Exercise care when moving the unit. Do not remove any packaging until the unit is near the place of installation. Rig the unit by attaching chain or cable slings to the lifting holes provided in the base rails. Spreader bars, whose length exceeds the largest dimension across the unit, **MUST** be used across the top of the unit.

### ⚠ CAUTION

*Before lifting, make sure the unit weight is distributed equally on the rigging cables so it will lift evenly.*

Units may be moved or lifted with a forklift. Slotted openings in the base rails are provided for this purpose.

**Table 2:** Weights and Dimensions

Model	Weight (lbs.)		Center of Gravity		4 Point Load Location (lbs.)			
	Shipping	Operating	X	Y	A	B	C	D
A24	348	343	30	15	96	105	107	40
A30	394	389	30	15	107	123	123	41
A36	400	395	30	15	112	123	120	45
A42	471	466	32	13	169	132	131	39
B48	488	483	30	19	158	125	130	75
B60	505	500	30	20	157	134	140	74

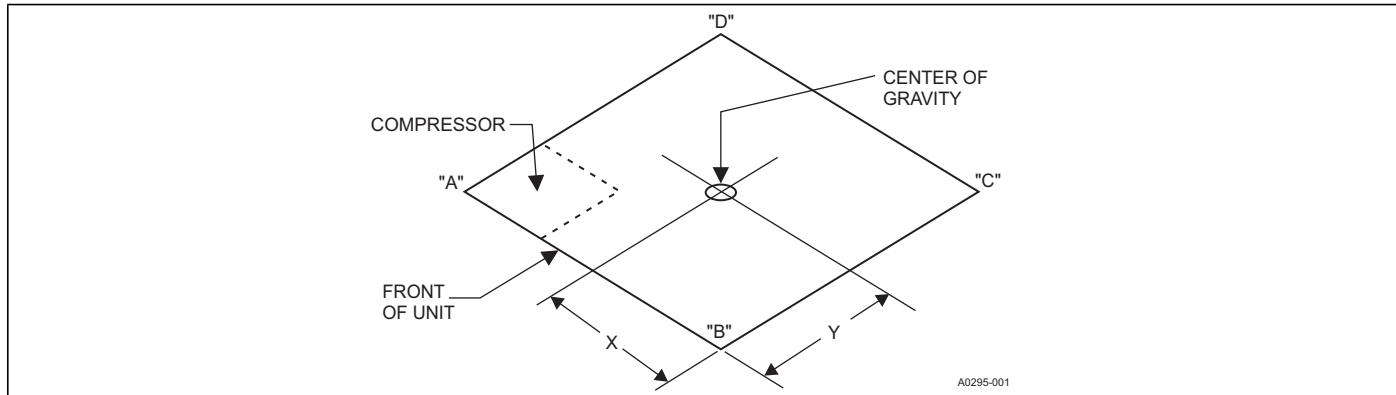

**FIGURE 2:** Unit 4 Point Load Weight

**Table 3:** Unit Dimensions

Model	Dimensions		
	A	B	C
A24	51-1/4	35-3/4	47
A30	51-1/4	35-3/4	47
A36	51-1/4	35-3/4	47
A42	51-1/4	35-3/4	49
B48	51-1/4	45-3/4	53
B60	51-1/4	45-3/4	55

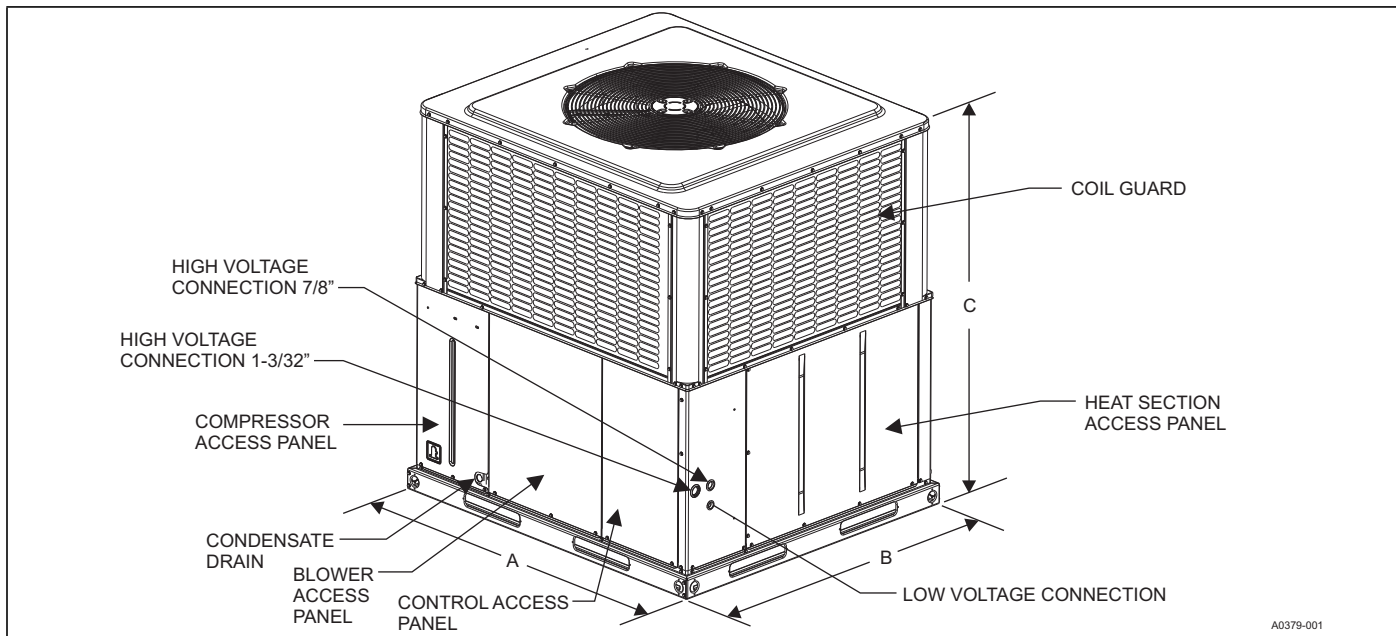

**FIGURE 3:** Unit Dimensions

**Table 4: Unit Clearances<sup>1,2</sup>**

Direction	Distance (in.)	Direction	Distance (in.)
Top <sup>3</sup>	36	Power Entry (Right Side)	36
Side Opposite Ducts	36	Left Side	24
Duct Panel	0	Bottom <sup>4</sup>	1

1. A 1" clearance must be provided between any combustible material and the supply air duct work.
2. The products of combustion must not be allowed to accumulate within a confined space and recirculate.
3. Units must be installed outdoors. Overhanging structures or shrubs must not obstruct condenser air discharge outlet.
4. Units may be installed on combustible materials made from wood or class A, B or C roof covering materials only if factory base rails are left in place as shipped.

**DUCTWORK**

NOTICE

*All units are shipped in the horizontal supply/return configuration. It is important to reduce the possibility of any air leakage through the bottom duct covers (resulting from cut, torn, or rolled gasket) due to improper handling or shipping processes. To ensure a good tight seal, it is recommended that silicone caulk and/or foil tape be applied along the cover edges.*

These units are adaptable to downflow use as well as rear supply and return air duct openings. To convert to downflow, use the following steps:

1. Remove the duct covers found in the bottom return and supply air duct openings. There are four (4) screws securing each duct cover (save these screws to use in Step 2).
2. Install the duct covers (removed in step one) to the rear supply and return air duct openings. Secure with the four (4) screws used in step one.
3. Seal duct covers with silicone caulk.

Duct work should be designed and sized according to the methods of the Air Conditioning Contractors of America (ACCA), as set forth in their Manual D.

A closed return duct system shall be used. This shall not preclude use of economizers or ventilation air intake. Flexible duct connectors are recommended in the supply and return duct work to minimize the transmission of vibration and noise.

⚠ CAUTION

*When fastening duct work to the side duct flanges on the unit, insert the screws through the duct flanges only. DO NOT insert the screws through the casing. Outdoor duct work must be insulated and water-proofed.*

NOTICE

*Be sure to note supply and return openings.*

Refer to Figures 4 and 5 for information concerning rear and bottom supply and return air duct openings.

**FILTERS**

Proper filter size is very important. Filter size, type and pressure drop should always be considered during duct system design.

Single phase units are shipped without a filter or filter racks. It is the responsibility of the installer to secure a filter in the return air ductwork or install a Filter/Frame Kit.

A filter rack and high velocity filters are standard on three phase units. Filters must always be used and must be kept clean. When filters become dirt laden, insufficient air will be delivered by the blower, decreasing your units efficiency and increasing operating costs and wear-and-tear on the unit and controls.

Filters should be checked monthly; this is especially important since this unit is used for both heating and cooling.

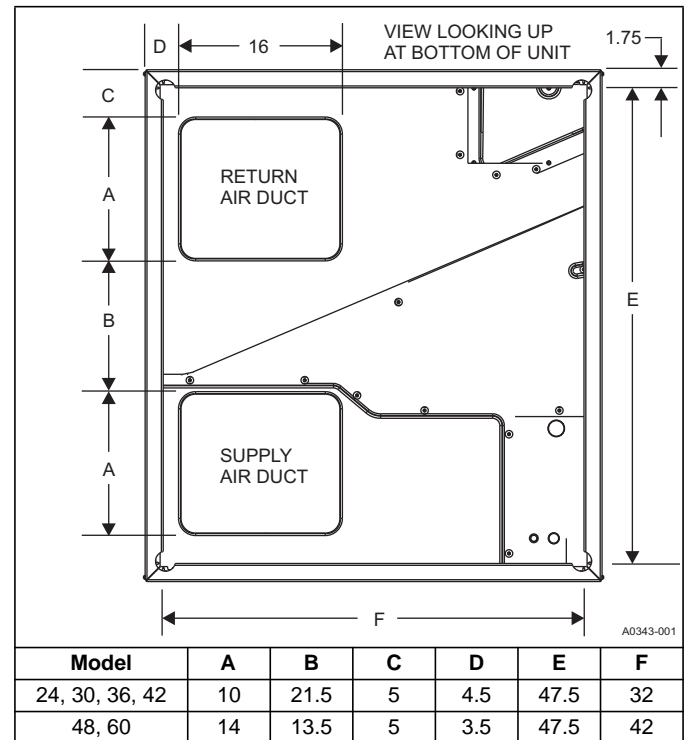

**FIGURE 4: Bottom Duct Dimensions (inches)**

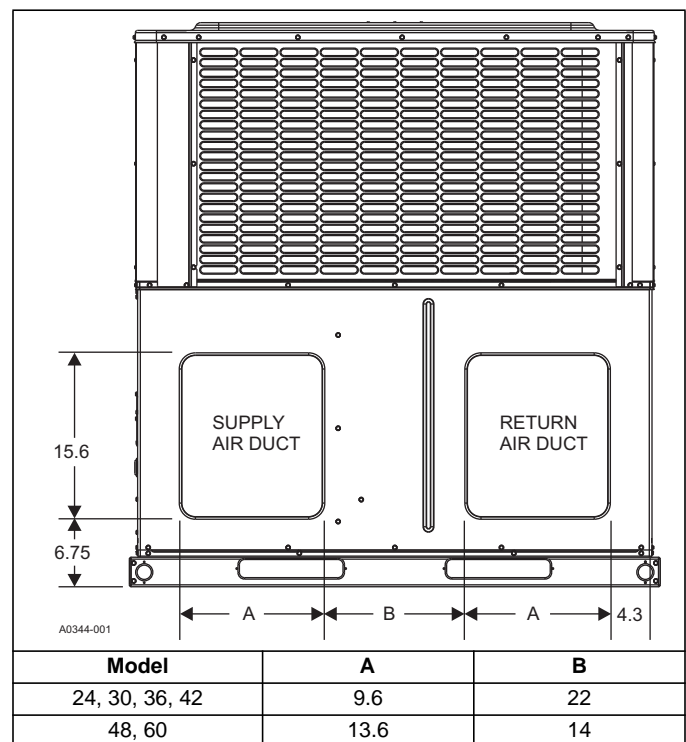

**FIGURE 5: Rear Duct Dimensions (inches)**

## CONDENSATE DRAIN

A condensate trap must be installed in the condensate drain. The plumbing must conform to local codes.

Use Teflon tape or pipe thread compound if needed.

### CAUTION

Hand tighten only.

## SERVICE ACCESS

Access to all serviceable components is provided at the following locations:

- Coil guards
- Unit top panel
- Corner posts
- Blower access panel
- Control access panel
- Indoor coil access panel
- Compressor access panel

Refer to Figure 3 for location of these access locations and minimum clearances in Table 4.

### CAUTION

This system uses R-410A Refrigerant which operates at higher pressures than R-22. No other refrigerant may be used in this system. Gage sets, hoses, refrigerant containers and recovery systems must be designed to handle R-410A. If you are unsure, consult the equipment manufacturer. Failure to use R-410A compatible servicing equipment may result in property damage or injury.

### WARNING

Wear safety glasses and gloves when handling refrigerants. Failure to follow this warning can cause serious personal injury.

Refer to Figure 14 for the R-410A Quick Reference Guide.

## THERMOSTAT

The room thermostat should be located on an inside wall approximately 60" above the floor where it will not be subject to drafts, sun exposure or heat from electrical fixtures or appliances. Sealant should be used behind thermostat to prevent air infiltration. Follow manufacturer's instructions enclosed with the thermostat for general installation procedure. Color coded insulated wires (minimum #18 AWG) should be used to connect thermostat to unit. See Figure 6. Do not use power stealing thermostats.

## POWER AND CONTROL WIRING

Field wiring to the unit must conform to provisions of the current N.E.C. ANSI/NFPA No. 70 or C.E.C. and/or local ordinances. The unit must be electrically grounded in accordance with local codes or, in their absence, with the N.E.C./C.E.C. Voltage tolerances which must be maintained at the compressor terminals during starting and running conditions are indicated on the unit Rating Plate and Table 1.

**The wiring entering the cabinet must be provided with mechanical strain relief.**

A fused disconnect switch should be field provided for the unit. If any of the wire supplied with the unit must be replaced, replacement wire must be of the type shown on the wiring diagram.

Electrical service must be sized properly to carry the load. Each unit must be wired with a separate branch circuit fed directly from the main distribution panel and properly fused.

Refer to Figures 6-8 for typical field wiring and to the appropriate unit wiring diagram for control circuit and power wiring information.

Unit comes wired for 230 volt power. If supply power is 208 volt, wires connected to the control transformer 230V tap must be moved to the 208V tap.

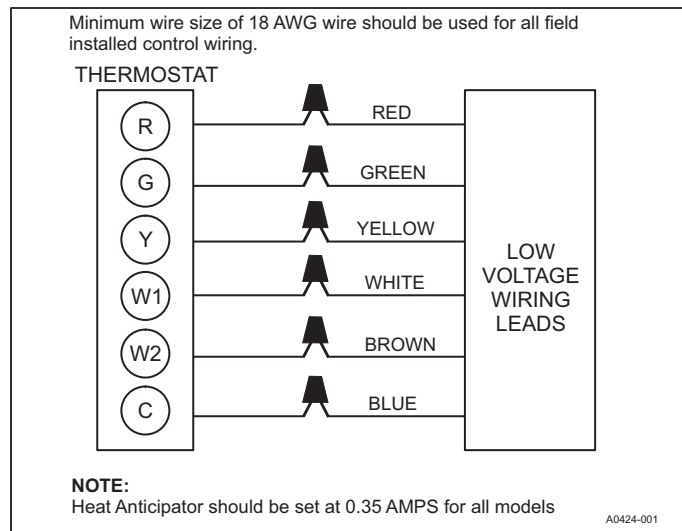

**FIGURE 6:** Typical Field Control Wiring Diagram For Air Conditioner Models

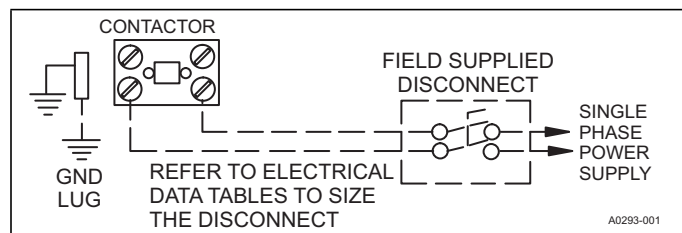

**FIGURE 7:** Typical Field Power Wiring Diagram

## NOTICE

In some applications, the service disconnects on the electric heat kits must be rotated 180° so the up position of the disconnect is the ON position. This service disconnect orientation change is required by UL 1995, Article 26.19 (in reference to all circuit breakers).

Table 5: Electrical Data - 208/230-1-60 Single Source Power

Model	Compressor			OD Fan Motor	Blower Motor	Electric Heat Option						MCA <sup>1</sup> (Amps)		Max Fuse <sup>2</sup> or Breaker <sup>3</sup> Size	
	RLA	LRA	MCC	FLA	FLA	Heater Kit <sup>4</sup>	Heater kW		Stages	Heater Amps		208	230	208	230
							208	230		208	230				
A24	9	45	14	1.3	3.8	none	--	--	--	--	--	16.0	16.0	20	20
						6HK16500206	1.8	2.2	1	8.7	9.6	16.0	16.7	20	20
						6HK16500506	3.6	4.4	1	17.3	19.1	25.4	27.7	30	30
						6HK16500806	5.8	7.1	1	27.9	30.9	38.7	42.4	40	45
						6HK16501006	7.2	8.8	1	34.6	38.3	47.1	51.6	50	60
						6HK16501306	9.4	11.5	2	45.2	50.0	60.1	66.3	70	70
A30	10	57	15	1.3	3.8	none	--	--	--	--	--	17.4	17.4	25	25
						6HK16500206	1.8	2.2	1	8.7	9.6	17.4	17.4	25	25
						6HK16500506	3.6	4.4	1	17.3	19.1	25.4	27.7	30	30
						6HK16500806	5.8	7.1	1	27.9	30.9	38.7	42.4	40	45
						6HK16501006	7.2	8.8	1	34.6	38.3	47.1	51.6	50	60
						6HK16501306	9.4	11.5	2	45.2	50.0	60.3	66.3	70	70
A36	13	78	23	1.3	3.8	none	--	--	--	--	--	21.4	21.4	30	30
						6HK16500206	1.8	2.2	1	8.7	9.6	21.4	21.4	30	30
						6HK16500506	3.6	4.4	1	17.3	19.1	25.4	27.7	30	30
						6HK16500806	5.8	7.1	1	27.9	30.9	38.7	42.4	40	45
						6HK16501006	7.2	8.8	1	34.6	38.3	47.1	51.6	50	60
						6HK16501306	9.4	11.5	2	45.2	50.0	60.3	66.3	70	70
A42	18	112	28	1.3	5.4	none	--	--	--	--	--	29.1	29.1	45	45
						6HK16500506	3.6	4.4	1	17.3	19.1	29.1	29.3	45	45
						6HK16500806	5.8	7.1	1	27.9	30.9	40.3	44.0	45	45
						6HK16501006	7.2	8.8	1	34.6	38.3	48.7	53.2	50	60
						6HK16501306	9.4	11.5	2	45.2	50.0	61.9	67.9	70	70
						6HK16501506	10.8	13.2	2	51.9	57.4	70.3	77.1	80	80
B48	22	117	34	1.7	5.4	none	--	--	--	--	--	34.4	34.4	50	50
						6HK16500506	3.6	4.4	1	17.3	19.1	34.4	34.4	50	50
						6HK16500806	5.8	7.1	1	27.9	30.9	40.3	44.0	50	50
						6HK16501006	7.2	8.8	1	34.6	38.3	48.7	53.2	50	60
						6HK16501306	9.4	11.5	2	45.2	50.0	61.9	67.9	70	70
						6HK16501506	10.8	13.2	2	51.9	57.4	70.3	77.1	80	80
B60	24	144	38	1.7	7.0	none	--	--	--	--	--	39.2	39.2	60	60
						6HK16500506	3.6	4.4	1	17.3	19.1	39.2	39.2	60	60
						6HK16500806	5.8	7.1	1	27.9	30.9	41.9	45.6	60	60
						6HK16501006	7.2	8.8	1	34.6	38.3	50.3	54.8	60	60
						6HK16501306	9.4	11.5	2	45.2	50.0	63.5	69.5	70	70
						6HK16501506	10.8	13.2	2	51.9	57.4	71.9	78.7	80	80
						6HK16501806	13.0	15.9	2	62.5	69.1	85.1	93.4	90	100
						6HK16502006	14.4	17.6	2	69.2	76.5	93.5	102.7	100	110

1. Minimum Circuit Ampacity.
2. Maximum Over Current Protection per standard UL 1995.
3. Fuse or HACR circuit breaker to be field installed.
4. Single Point Connection Kit required.

Table 6: Electrical Data for 208-1-60 Multi Source Power

Model	Compressor			OD Fan Motor	Blower Motor	Electric Heat Option				Multi Source								
	RLA	LRA	MCC			FLA	FLA	Heater Kit	Heater kW	Stages	Heater Amps	208	208	208	208	208	208	208
				208	208				MCA <sup>1</sup> Amps		MOP <sup>2</sup>							
Multi Source: Compressor Circuit and Heat Circuits						Multi Source:	Circuit #1 Compressor Circuit											
							Circuit #2 Heat				MCA <sup>1</sup> Amps	MOP <sup>2</sup>	MCA <sup>1</sup> Amps	MOP <sup>2</sup>	MCA <sup>1</sup> Amps	MOP <sup>2</sup>	MCA <sup>1</sup> Amps	MOP <sup>2</sup>
							Circuit #2 Heat				Circuit #1		Circuit #2		Circuit #3		Circuit #4	
							Circuit #3 Heat				Circuit #1		Circuit #2		Circuit #3		Circuit #4	
A24	9	45	14	1.3	3.8	none	--	--	--	16.0	20	--	--	--	--	--	--	
						6HK(0,1)6500206	1.8	1	8.7	16.0	20	10.8	15	--	--	--	--	
						6HK(0,1)6500506	3.6	1	17.3	16.0	20	21.6	25	--	--	--	--	
						6HK(0,1)6500806	5.8	1	27.9	16.0	20	34.9	40	--	--	--	--	
						6HK(0,1)6501006	7.2	1	34.6	16.0	20	43.3	45	--	--	--	--	
						6HK16501306	9.4	2	45.2	16.0	20	37.7	40	18.8	20	--	--	
A30	10	57	15	1.3	3.8	none	--	--	--	17.4	25	--	--	--	--	--	--	
						6HK(0,1)6500206	1.8	1	8.7	17.4	25	10.8	15	--	--	--	--	
						6HK(0,1)6500506	3.6	1	17.3	17.4	25	21.6	25	--	--	--	--	
						6HK(0,1)6500806	5.8	1	27.9	17.4	25	34.9	40	--	--	--	--	
						6HK(0,1)6501006	7.2	1	34.6	17.4	25	43.3	45	--	--	--	--	
						6HK16501306	9.4	2	45.2	17.4	25	37.7	40	18.8	20	--	--	
						6HK16501506	10.8	2	51.9	17.4	25	43.3	50	21.6	25	--	--	
						6HK26501306	9.4	1	45.2	17.4	25	56.5	60	--	--	--	--	
A36	13	78	23	1.3	3.8	none	--	--	--	21.4	30	--	--	--	--	--	--	
						6HK(0,1)6500206	1.8	1	8.7	21.4	30	10.8	15	--	--	--	--	
						6HK(0,1)6500506	3.6	1	17.3	21.4	30	21.6	25	--	--	--	--	
						6HK(0,1)6500806	5.8	1	27.9	21.4	30	34.9	40	--	--	--	--	
						6HK(0,1)6501006	7.2	1	34.6	21.4	30	43.3	45	--	--	--	--	
						6HK16501306	9.4	2	45.2	21.4	30	37.7	40	18.8	20	--	--	
						6HK16501506	10.8	2	51.9	21.4	30	43.3	50	21.6	25	--	--	
						6HK26501306	9.4	1	45.2	21.4	30	56.5	60	--	--	--	--	
A42	18	112	28	1.7	5.4	none	--	1	--	29.5	45	--	--	--	--	--	--	
						6HK(0,1)6500506	3.6	1	17.3	29.5	45	21.6	25	--	--	--	--	
						6HK(0,1)6500806	5.8	1	27.9	29.5	45	34.9	40	--	--	--	--	
						6HK(0,1)6501006	7.2	1	34.6	29.5	45	43.3	45	--	--	--	--	
						6HK16501306	9.4	2	45.2	29.5	45	56.5	40	21.6	20	--	--	
						6HK16501506	10.8	2	51.9	29.5	45	43.3	50	21.6	25	--	--	
						6HK16501806	13.0	2	62.5	29.5	45	52.1	40	26.0	40	--	--	
						6HK16502006	14.4	2	69.2	29.5	45	43.3	45	43.3	45	--	--	
						6HK26501306	9.4	1	45.2	29.5	45	56.5	60	--	--	--	--	
						6HK26501506	10.8	1	51.9	29.5	45	64.9	70	--	--	--	--	
						6HK26501806	13.0	1	62.5	29.5	45	78.1	80	--	--	--	--	
B48	22	117	34	1.7	5.4	none	--	--	--	34.4	50	--	--	--	--	--	--	
						6HK(0,1)6500506	3.6	1	17.3	34.4	50	21.6	25	--	--	--	--	
						6HK(0,1)6500806	5.8	1	27.9	34.4	50	34.9	40	--	--	--	--	
						6HK(0,1)6501006	7.2	1	34.6	34.4	50	43.3	45	--	--	--	--	
						6HK16501306	9.4	2	45.2	34.4	50	56.5	40	21.6	20	--	--	
						6HK16501506	10.8	2	51.9	34.4	50	43.3	50	21.6	25	--	--	
						6HK16501806	13.0	2	62.5	34.4	50	52.1	40	26.0	40	--	--	
						6HK16502006	14.4	2	69.2	34.4	50	43.3	45	43.3	45	--	--	
						6HK26501306	9.4	1	45.2	34.4	50	56.5	60	--	--	--	--	
						6HK26501506	10.8	1	51.9	34.4	50	64.9	70	--	--	--	--	
						6HK26501806	13.0	1	62.5	34.4	50	78.1	80	--	--	--	--	

For notes, see Page 10.

**Table 6:** Electrical Data for 208-1-60 Multi Source Power (Continued)

Model	Compressor			OD Fan Motor	Blower Motor	Electric Heat Option				Multi Source								
	RLA	LRA	MCC	FLA	FLA	Heater Kit	Heater kW	Stages	Heater Amps	208	208	208	208	208	208	208	208	
							208		208									
Multi Source: Compressor Circuit and Heat Circuits						Multi Source:	Circuit #1 Compressor Circuit				MCA <sup>1</sup> Amps	MOP <sup>2</sup>	MCA <sup>1</sup> Amps	MOP <sup>2</sup>	MCA <sup>1</sup> Amps	MOP <sup>2</sup>	MCA <sup>1</sup> Amps	MOP <sup>2</sup>
							Circuit #2 Heat											
							Circuit #2 Heat											
							Circuit #3 Heat											
B60	24	144	38	1.7	7.0	none	--	--	--	39.2	60	--	--	--	--	--	--	
						6HK(0,1)6500506	3.6	1	17.3	39.2	60	21.6	25	--	--	--	--	
						6HK(0,1)6500806	5.8	1	27.9	39.2	60	34.9	40	--	--	--	--	
						6HK(0,1)6501006	7.2	1	34.6	39.2	60	43.3	45	--	--	--	--	
						6HK16501306	9.4	2	45.2	39.2	60	56.5	40	21.6	20	--	--	
						6HK16501506	10.8	2	51.9	39.2	60	43.3	50	21.6	25	--	--	
						6HK16501806	13.0	2	62.5	39.2	60	52.1	40	26.0	40	--	--	
						6HK16502006	14.4	2	69.2	39.2	60	43.3	45	43.3	45	--	--	
						6HK26501306	9.4	1	45.2	39.2	60	56.5	60	--	--	--	--	
						6HK26501506	10.8	1	51.9	39.2	60	64.9	70	--	--	--	--	
						6HK26501806	13.0	1	62.5	39.2	60	78.1	80	--	--	--	--	
						6HK26502006	14.4	1	69.2	39.2	60	86.5	90	--	--	--	--	
						6HK16502506	18.0	3	86.5	39.2	60	43.3	45	43.3	45	21.6	25	
6HK26502506	18.0	1	86.5	39.2	60	108.2	110	--	--	--	--							

1. MCA = Minimum Circuit Ampacity.
2. MOP = Maximum Over Current Protection device; must be HACR type circuit breaker or time delay fuse.

**Table 7:** Electrical Data for 230-1-60 Multi Source Power

Model	Compressor			OD Fan Motor	Blower Motor	Electric Heat Option				Multi Source								
	RLA	LRA	MCC	FLA	FLA	Heater Kit	Heater kW	Stages	Heater Amps	230	230	230	230	230	230	230	230	
							230		230									
Multi Source: Compressor Circuit and Heat Circuits						Multi Source:	Circuit #1 Compressor Circuit				MCA <sup>1</sup> Amps	MOP <sup>2</sup>	MCA <sup>1</sup> Amps	MOP <sup>2</sup>	MCA <sup>1</sup> Amps	MOP <sup>2</sup>	MCA <sup>1</sup> Amps	MOP <sup>2</sup>
							Circuit #2 Heat											
							Circuit #2 Heat											
							Circuit #3 Heat											
A24	9	45	14	1.3	3.8	none	--	--	--	16.0	20	--	--	--	--	--	--	
						6HK(0,1)6500206	2.2	1	9.6	16.0	20	12.0	15	--	--	--	--	
						6HK(0,1)6500506	4.4	1	19.1	16.0	20	23.9	25	--	--	--	--	
						6HK(0,1)6500806	7.1	1	30.9	16.0	20	38.6	40	--	--	--	--	
						6HK(0,1)6501006	8.8	1	38.3	16.0	20	47.8	50	--	--	--	--	
						6HK16501306	11.5	2	50.0	16.0	20	41.7	45	20.8	25	--	--	
						6HK26501306	11.5	1	50.0	16.0	20	62.5	70	--	--	--	--	
A30	10	57	15	1.3	3.8	none	--	--	--	17.4	25	--	--	--	--	--	--	
						6HK(0,1)6500206	2.2	1	9.6	17.4	25	12.0	15	--	--	--	--	
						6HK(0,1)6500506	4.4	1	19.1	17.4	25	23.9	25	--	--	--	--	
						6HK(0,1)6500806	7.1	1	30.9	17.4	25	38.6	40	--	--	--	--	
						6HK(0,1)6501006	8.8	1	38.3	17.4	25	47.8	50	--	--	--	--	
						6HK16501306	11.5	2	50.0	17.4	25	41.7	45	20.8	25	--	--	
						6HK16501506	13.2	2	57.4	17.4	25	47.8	50	23.9	25	--	--	
6HK26501306	11.5	1	50.0	17.4	25	62.5	70	--	--	--	--							
6HK26501506	13.2	1	57.4	17.4	25	71.7	80	--	--	--	--							
A36	13	78	23	1.3	3.8	none	--	--	--	21.4	30	--	--	--	--	--	--	
						6HK(0,1)6500206	2.2	1	9.6	21.4	30	12.0	15	--	--	--	--	
						6HK(0,1)6500506	4.4	1	19.1	21.4	30	23.9	25	--	--	--	--	
						6HK(0,1)6500806	7.1	1	30.9	21.4	30	38.6	40	--	--	--	--	
						6HK(0,1)6501006	8.8	1	38.3	21.4	30	47.8	50	--	--	--	--	
						6HK16501306	11.5	2	50.0	21.4	30	41.7	45	20.8	25	--	--	
						6HK16501506	13.2	2	57.4	21.4	30	47.8	50	23.9	25	--	--	
6HK26501306	11.5	1	50.0	21.4	30	62.5	70	--	--	--	--							
6HK26501506	13.2	2	57.4	21.4	30	71.7	80	--	--	--	--							

For notes, see Page 11.

Table 7: Electrical Data for 230-1-60 Multi Source Power

Model	Compressor			OD Fan Motor	Blower Motor	Electric Heat Option				Multi Source								
	RLA	LRA	MCC	FLA	FLA	Heater Kit	Heater kW	Stages	Heater Amps	230	230	230	230	230	230	230		
							230		230									
Multi Source: Compressor Circuit and Heat Circuits						Multi Source:	Circuit #1 Compressor Circuit											
							Circuit #2 Heat				MCA <sup>1</sup> Amps	MOP <sup>2</sup>	MCA <sup>1</sup> Amps	MOP <sup>2</sup>	MCA <sup>1</sup> Amps	MOP <sup>2</sup>	MCA <sup>1</sup> Amps	MOP <sup>2</sup>
							Circuit #2 Heat				Circuit #1		Circuit #2		Circuit #3		Circuit #4	
							Circuit #3 Heat				Circuit #1		Circuit #2		Circuit #3		Circuit #4	
A42	18	112	28	1.7	5.4	none	--	1	--	29.5	45	--	--	--	--	--		
						6HK(0,1)6500506	4.4	1	19.1	29.5	45	23.9	25	--	--	--	--	
						6HK(0,1)6500806	7.1	1	30.9	29.5	45	38.6	40	--	--	--	--	
						6HK(0,1)6501006	8.8	1	38.3	29.5	45	47.8	50	--	--	--	--	
						6HK16501306	11.5	2	50.0	29.5	45	62.5	45	23.9	25	--	--	
						6HK16501506	13.2	2	57.4	29.5	45	47.8	50	23.9	25	--	--	
						6HK16501806	15.9	2	69.1	29.5	45	57.6	45	28.8	45	--	--	
						6HK16502006	17.6	2	76.5	29.5	45	47.8	50	47.8	50	--	--	
						6HK26501306	11.5	1	50.0	29.5	45	62.5	70	--	--	--	--	
						6HK26501506	13.2	1	57.4	29.5	45	71.7	80	--	--	--	--	
						6HK26501806	15.9	1	69.1	29.5	45	86.4	90	--	--	--	--	
						6HK26502006	17.6	1	76.5	29.5	45	95.7	100	--	--	--	--	
B48	22	117	34	1.7	5.4	none	--	--	--	34.4	50	--	--	--	--	--		
						6HK(0,1)6500506	4.4	1	19.1	34.4	50	23.9	25	--	--	--	--	
						6HK(0,1)6500806	7.1	1	30.9	34.4	50	38.6	40	--	--	--	--	
						6HK(0,1)6501006	8.8	1	38.3	34.4	50	47.8	50	--	--	--	--	
						6HK16501306	11.5	2	50.0	34.4	50	62.5	45	23.9	25	--	--	
						6HK16501506	13.2	2	57.4	34.4	50	47.8	50	23.9	25	--	--	
						6HK16501806	15.9	2	69.1	34.4	50	57.6	45	28.8	45	--	--	
						6HK16502006	17.6	2	76.5	34.4	50	47.8	50	47.8	50	--	--	
						6HK26501306	11.5	1	50.0	34.4	50	62.5	70	--	--	--	--	
						6HK26501506	13.2	1	57.4	34.4	50	71.7	80	--	--	--	--	
						6HK26501806	15.9	1	69.1	34.4	50	86.4	90	--	--	--	--	
						6HK26502006	17.6	2	76.5	34.4	50	95.7	100	--	--	--	--	
B60	24	144	38	1.7	7.0	none	--	--	--	39.2	60	--	--	--	--	--		
						6HK(0,1)6500506	4.4	1	19.1	39.2	60	23.9	25	--	--	--	--	
						6HK(0,1)6500806	7.1	1	30.9	39.2	60	38.6	40	--	--	--	--	
						6HK(0,1)6501006	8.8	1	38.3	39.2	60	47.8	50	--	--	--	--	
						6HK16501306	11.5	2	50.0	39.2	60	62.5	45	23.9	25	--	--	
						6HK16501506	13.2	2	57.4	39.2	60	47.8	50	23.9	25	--	--	
						6HK16501806	15.9	2	69.1	39.2	60	57.6	45	28.8	45	--	--	
						6HK16502006	17.6	2	76.5	39.2	60	47.8	50	47.8	50	--	--	
						6HK26501306	11.5	1	50.0	39.2	60	62.5	70	--	--	--	--	
						6HK26501506	13.2	1	57.4	39.2	60	71.7	80	--	--	--	--	
						6HK26501806	15.9	1	69.1	39.2	60	86.4	90	--	--	--	--	
						6HK26502006	17.6	1	76.5	39.2	60	95.7	100	--	--	--	--	
						6HK16502506	22.0	3	95.7	39.2	60	47.8	50	47.8	50	23.9	25	
6HK26502506	22.0	1	95.7	39.2	60	119.6	125	--	--	--	--							

1. MCA = Minimum Circuit Ampacity.

2. MOP = Maximum Over Current Protection device; must be HACR type circuit breaker or time delay fuse.

**Table 8:** Single-point Wiring Kits

Single Point Kit P/N	Unit Model Number	Breaker Size	Heat Kit
S1-2SPWK008	PCE4A24	20 Amp	up to 13 kW
S1-2SPWK006	PCE4A30	25 Amp	up to 15 kW
S1-2SPWK001	PCE4A36	30 Amp	up to 15 kW
S1-2SPWK003	PCE4A42	45 Amp	up to 20 kW
S1-2SPWK004	PCE4B48	50 Amp	up to 20 kW
S1-2SPWK005	PCE4B60	60 Amp	up to 20 kW

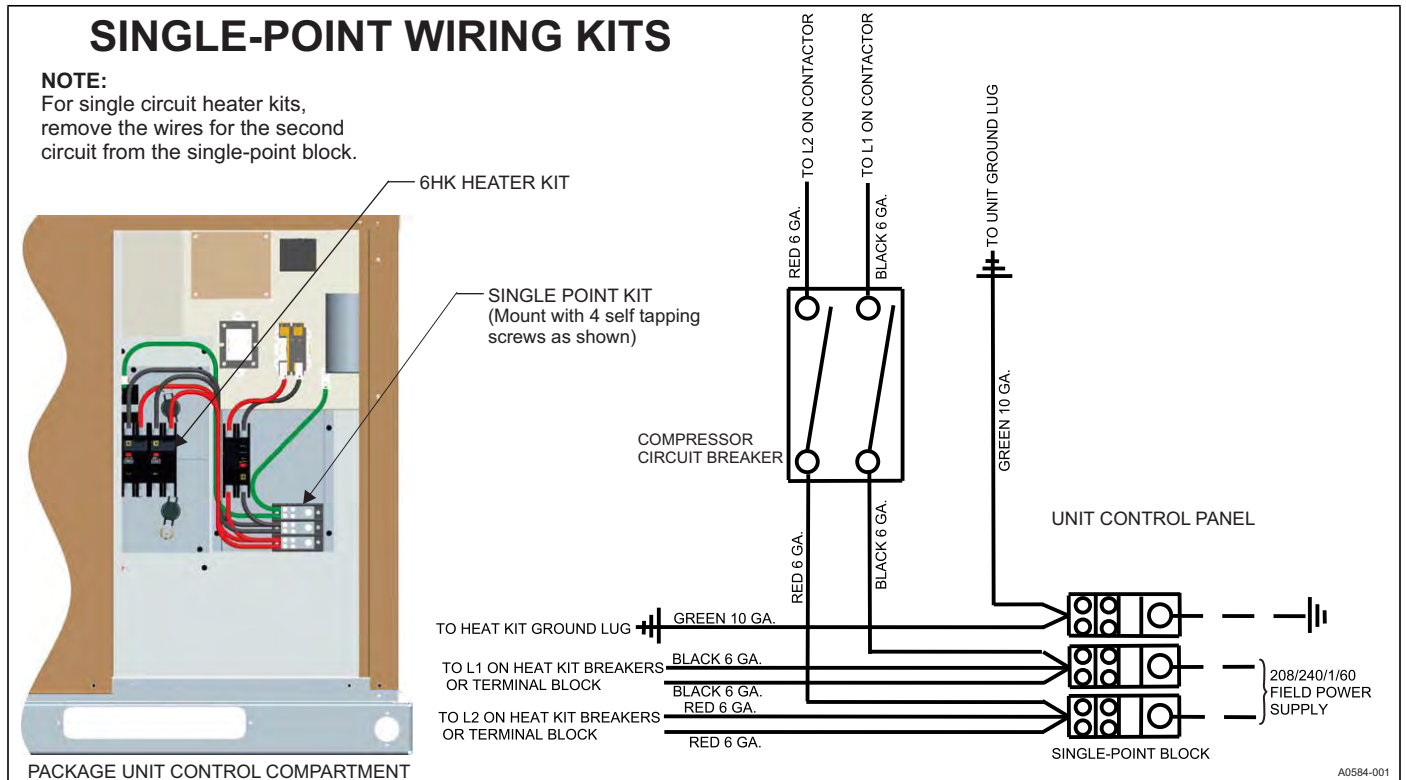

**FIGURE 8:** Single Point Wiring Kits

**Table 9:** Physical Data

NOMINAL TONNAGE	MODELS					
	A24	A30	A36	A42	B48	B60
	2.0	2.5	3.0	3.5	4.0	5.0
<b>AHRI Cooling Performance</b>						
Gross Capacity @ AHRI A point (MBH)	23.7	30.1	37.2	43.5	47.7	55.0
AHRI net capacity (MBH)	22.8	29.0	34.6	40.7	45.5	52.5
EER	11.0	11.0	11.0	11.0	11.0	11.0
SEER	14.0	14.0	14.0	14.0	14.0	14.0
Nominal CFM	800	1000	1200	1400	1600	2000
System power (KW)	2.1	2.6	3.2	3.8	4.2	4.8
Refrigerant type	R410A	R410A	R410A	R410A	R410A	R410A
Refrigerant charge (lb-oz)	5-4	8-8	8-3	9-4	14-4	14-2
<b>Dimensions (inches)</b>						
Length	51-1/4	51-1/4	51-1/4	51-1/4	51-1/4	51-1/4
Width	35-3/4	35-3/4	35-3/4	35-3/4	45-3/4	45-3/4
Height	47	47	47	49	53	55
<b>Operating WT. (lbs.)</b>	343	389	395	466	483	500
<b>Compressors</b>						
Type	Recip	Recip	Recip	Scroll	Scroll	Scroll
<b>Outdoor Coil Data</b>						
Face area (Sq. Ft.)	15.3	15.3	15.3	17.3	24.1	26.3
Rows	1	2	2	2	2	2
Fins per inch	22	22	22	22	22	22
Tube diameter	3/8	3/8	3/8	3/8	3/8	3/8
Circuitry Type	Interlaced	Interlaced	Interlaced	Interlaced	Interlaced	Interlaced
<b>Indoor Coil Data</b>						
Face area (Sq. Ft.)	3.4	3.4	3.4	3.4	4.4	4.4
Rows	2	3	3	3	3	3
Fins per inch	16	16	16	16	16	16
Tube diameter	3/8	3/8	3/8	3/8	3/8	3/8
Circuitry Type	Interlaced	Interlaced	Interlaced	Interlaced	Interlaced	Interlaced
Refrigerant control	TXV	TXV	TXV	TXV	TXV	TXV
<b>Outdoor Fan Data</b>						
Fan diameter (Inch)	24	24	24	24	26	26
Type	Prop	Prop	Prop	Prop	Prop	Prop
Drive type	Direct	Direct	Direct	Direct	Direct	Direct
No. speeds	1	1	1	1	1	1
Motor HP each	1/4	1/4	1/4	1/4	1/3	1/3
RPM	850	850	850	850	850	850
Nominal total CFM	2400	2400	2400	2400	3200	3200
<b>Direct Drive Indoor Blower Data</b>						
Fan Size (Inch)	11 x 8	11 x 8	11 x 10	11 x 10	11 x 10	11 x 10
Type	Centrifugal	Centrifugal	Centrifugal	Centrifugal	Centrifugal	Centrifugal
Motor HP each	1/2	1/2	1/2	3/4	3/4	1
RPM	1200 Max	1200 Max	1200 Max	1200 Max	1200 Max	1200 Max
Frame size	48	48	48	48	48	48
<b>Filters</b>						
Filter Size	A	A	A	A	B	B
Quantity size	Field-supplied external filters must be sized so as not to exceed 300 fpm air velocity through disposable filters. For internal filter use, a filter rack kit is available. Consult the instructions supplied with that kit for replacement filter sizes. Filter sizes: A=20X20, B=20X30.					

## COMPRESSORS

**▲ CAUTION**

*This system uses R-410A Refrigerant which operates at higher pressures than R-22. No other refrigerant may be used in this system.*

The compressor used in this product is specifically designed to operate with R-410A Refrigerant and cannot be interchanged.

The compressor uses polyolester (POE oil), Mobile 3MA POE. This oil is extremely hygroscopic, meaning it absorbs water readily. POE oil can absorb 15 times as much water as other oils designed for HCFC and CFC refrigerants. If refrigerant circuit is opened, take all necessary precautions to avoid exposure of the oil to the atmosphere.

**▲ CAUTION**

*Do not leave the system open to the atmosphere. Unit damage could occur due to moisture being absorbed by the **POE oil** in the system. This type of oil is highly susceptible to moisture absorption*

POE (polyolester) compressor lubricants are known to cause long term damage to some synthetic roofing materials.

**▲ CAUTION**

*Exposure, even if immediately cleaned up, may cause embrittlement (leading to cracking) to occur in one year or more. When performing any service that may risk exposure of compressor oil to the roof, take precautions to protect roofing.*

Procedures which risk oil leakage include, but are not limited to, compressor replacement, repairing refrigerant leaks, replacing refrigerant components such as filter drier, pressure switch, metering device or coil.

**▲ CAUTION**

*Do not loosen compressor mounting bolts.*

Units are shipped with compressor mountings which are factory-adjusted and ready for operation.

## SECTION V: AIRFLOW PERFORMANCE

**Table 10:** Airflow Performance - Side Duct Application

Model	Motor Speed	External Static Pressure (Inches WC)								
		0.1	0.2	0.3	0.4	0.5	0.6	0.7	0.8	1.0
		SCFM	SCFM	SCFM	SCFM	SCFM	SCFM	SCFM	SCFM	SCFM
A24	Low (1)	887	847	802	750	705	664	613	563	463
	Low/Medium (2)	978	941	898	850	803	759	713	667	575
	Medium (3)	1171	1114	1074	1039	993	949	906	864	780
	Medium/High (4)	1349	1297	1265	1224	1185	1146	1107	1063	975
	High (5)	1487	1462	1392	1331	1318	1281	1241	1201	1121
A30	Low (1)	1076	1020	984	943	903	859	819	779	699
	Low/Medium (2)	1102	1048	1010	974	934	890	850	810	730
	Medium (3)	1191	1140	1112	1076	1038	1000	958	919	841
	Medium/High (4)	1201	1225	1187	1151	1118	1080	1041	1002	924
	High (5)	1370	1329	1283	1271	1209	1176	1143	1109	1041
A36	Low (1)	1225	1174	1131	1090	1046	993	941	888	782
	Low/Medium (2)	1259	1209	1166	1126	1084	1032	980	928	824
	Medium (3)	1314	1271	1229	1186	1144	1097	1049	998	896
	Medium/High (4)	1348	1306	1259	1222	1179	1133	1086	1036	936
	High (5)	1506	1471	1403	1389	1345	1305	1262	1216	1124
A42	Low (1)	1436	1382	1342	1304	1262	1220	1179	1131	1035
	Low/Medium (2)	1544	1492	1455	1416	1376	1336	1294	1248	1156
	Medium (3)	1573	1523	1484	1445	1408	1367	1327	1279	1183
	Medium/High (4)	1681	1640	1599	1557	1517	1478	1436	1393	1307
	High (5)	1935	1887	1834	1788	1743	1701	1651	1591	1471
B48	Low (1)	1620	1564	1517	1466	1418	1360	1308	1206	1002
	Low/Medium (2)	1694	1630	1580	1530	1482	1430	1380	1292	1116
	Medium (3)	1798	1722	1669	1620	1572	1527	1480	1413	1280
	Medium/High (4)	1835	1758	1703	1653	1604	1558	1511	1442	1304
	High (5)	2146	2085	2025	1960	1872	1862	1798	1735	1609
B60	Low (1)	1730	1682	1628	1592	1552	1517	1479	1439	1359
	Low/Medium (2)	1858	1807	1749	1710	1667	1629	1589	1546	1460
	Medium (3)	2054	1998	1934	1890	1843	1801	1757	1710	1616
	Medium/High (4)	2195	2144	2098	2049	2003	1955	1883	1868	1838
	High (5)	2445	2388	2306	2293	2235	2178	2129	2077	1973

1. Airflow tested with dry coil conditions, without air filters, at 230 volts.
2. Applications above 0.8" w.c. external static pressure are not recommended.
3. Brushless DC high efficiency standard ECM blower motor used for all indoor blower assemblies.
4. Minimal variations in airflow performance data results from operating at 208 volts. Data above may be used in those cases.
5. Heating applications tested at 0.50" w.c. esp, and cooling applications tested at 0.30" w.c. esp per standards.

**Table 11:** Airflow Performance - Bottom Duct Application

Model	Motor Speed	External Static Pressure (Inches WC)								
		0.1	0.2	0.3	0.4	0.5	0.6	0.7	0.8	1.0
		SCFM	SCFM	SCFM	SCFM	SCFM	SCFM	SCFM	SCFM	SCFM
A24	Low (1)	899	869	827	782	734	685	630	575	465
	Low/Medium (2)	1033	960	924	879	834	787	735	685	585
	Medium (3)	1186	1133	1095	1056	1016	975	935	891	803
	Medium/High (4)	1357	1322	1284	1248	1211	1174	1127	1087	1007
	High (5)	1480	1439	1404	1367	1369	1299	1264	1226	1150
A30	Low (1)	1076	1042	1009	969	930	890	849	808	726
	Low/Medium (2)	1104	1063	1025	987	947	908	869	830	752
	Medium (3)	1205	1170	1136	1098	1060	1025	985	943	859
	Medium/High (4)	1285	1251	1213	1179	1141	1104	1065	1027	951
	High (5)	1406	1375	1341	1306	1271	1236	1198	1163	1093
A36	Low (1)	1231	1186	1146	1103	1069	1030	977	912	781
	Low/Medium (2)	1270	1225	1189	1140	1098	1046	1008	960	866
	Medium (3)	1317	1286	1245	1198	1151	1110	1064	1024	943
	Medium/High (4)	1358	1317	1275	1238	1197	1148	1105	1057	961
	High (5)	1517	1475	1447	1400	1357	1318	1275	1232	1146
A42	Low (1)	1455	1414	1379	1335	1294	1254	1212	1160	1056
	Low/Medium (2)	1566	1532	1492	1455	1416	1372	1333	1280	1174
	Medium (3)	1565	1530	1491	1458	1419	1381	1336	1290	1198
	Medium/High (4)	1675	1641	1606	1578	1535	1495	1455	1412	1326
	High (5)	1946	1909	1863	1815	1771	1721	1654	1595	1477
B48	Low (1)	1598	1548	1502	1454	1410	1362	1307	1251	1139
	Low/Medium (2)	1663	1612	1568	1522	1476	1422	1370	1297	1152
	Medium (3)	1789	1733	1670	1650	1596	1578	1535	1483	1379
	Medium/High (4)	1931	1814	1808	1736	1673	1650	1597	1519	1362
	High (5)	2131	2058	1998	1949	1892	1840	1788	1728	1608
B60	Low (1)	1655	1612	1596	1531	1461	1462	1429	1391	1316
	Low/Medium (2)	1766	1720	1667	1629	1632	1539	1537	1498	1421
	Medium (3)	1987	1933	1861	1817	1820	1715	1725	1651	1504
	Medium/High (4)	2114	2050	2047	1974	1899	1889	1920	1866	1758
	High (5)	2369	2308	2249	2183	2126	2088	2034	1990	1902

- Airflow tested with dry coil conditions, without air filters, at 230 volts.
- Applications above 0.8" w.c. external static pressure are not recommended.
- Brushless DC high efficiency standard ECM blower motor used for all indoor blower assemblies.
- Minimal variations in airflow performance data results from operating at 208 volts. Data above may be used in those cases.
- Heating applications tested at 0.50" w.c. esp, and cooling applications tested at 0.30" w.c. esp per standards.

**Table 12:** Electric Heat Minimum Supply Air

Model	Voltage	Minimum Blower Speed for Electric Heat								
		Heater kW								
		2	5	8	10	13	15	18	20	25
24	208/230-1-60	Low #1	Low #1	Med. Low #2	Med. #3	Med. Hi #4	--	--	--	--
30	208/230-1-60	Low #1	Low #1	Low #1	Med. Low #2	Med #3	High #5	--	--	--
36	208/230-1-60	Low #1	Low #1	Low #1	Low #1	Med. Low #2	High #5	--	--	--
42	208/230-1-60	--	Low #1	Low #1	Low #1	Low #1	Med. Low #2	Med. Hi #4	High #5	--
48	208/230-1-60	--	Low #1	Low #1	Low #1	Low #1	Low #1	Med. Low #2	Med. High #4	--
60	208/230-1-60	--	Low #1	Low #1	Low #1	Low #1	Low #1	Low #1	Med. Low #2	Med. High #4

**Table 13:** Electric Heat Multipliers

Voltage		kW Capacity Multipliers <sup>1</sup>
Nominal	Applied	
240	208	0.75
	230	0.92

- Electric heaters are rated at nominal voltage. Use this table to determine the electric heat capacity for heaters applied at lower voltages.

**Table 14:** Additional Static Resistance

Size (Tons)	CFM	Wet Indoor Coil	Economizer <sup>1</sup>	Filter/Frame Kit
24 (2.0)	500	0.01	0.00	0.01
	600	0.01	0.00	0.02
	700	0.01	0.00	0.04
	800	0.02	0.01	0.06
	900	0.03	0.01	0.08
	1000	0.04	0.01	0.10
	1100	0.05	0.01	0.13
	1200	0.06	0.02	0.16
30 (2.5)	700	0.01	0.00	0.04
	800	0.02	0.01	0.06
	900	0.03	0.01	0.08
	1000	0.04	0.01	0.10
	1100	0.05	0.01	0.13
	1200	0.06	0.02	0.16
	1300	0.07	0.03	0.17
36 (3.0)	700	0.01	0.00	0.04
	800	0.02	0.01	0.06
	900	0.03	0.01	0.08
	1000	0.04	0.01	0.10
	1100	0.05	0.01	0.13
	1200	0.06	0.02	0.16
	1300	0.07	0.03	0.17
	1400	0.08	0.04	0.18
42 (3.5)	1100	0.02	0.02	0.04
	1200	0.03	0.02	0.04
	1300	0.04	0.02	0.05
	1400	0.05	0.03	0.05
	1500	0.06	0.04	0.06
	1600	0.07	0.04	0.07
	1700	0.07	0.04	0.08
	1800	0.08	0.04	0.09
	1900	0.09	0.05	0.10
2000	0.09	0.05	0.11	
48 (4.0)	1100	0.02	0.02	0.04
	1200	0.03	0.02	0.04
	1300	0.04	0.02	0.05
	1400	0.05	0.03	0.05
	1500	0.06	0.04	0.06
	1600	0.07	0.04	0.07
	1700	0.07	0.04	0.08
	1800	0.08	0.04	0.09
	1900	0.09	0.05	0.10
	2000	0.09	0.05	0.11
60 (5.0)	1100	0.02	0.02	0.04
	1200	0.03	0.02	0.04
	1300	0.04	0.02	0.05
	1400	0.05	0.03	0.05
	1500	0.06	0.04	0.06
	1600	0.07	0.04	0.07
	1700	0.07	0.04	0.08
	1800	0.08	0.04	0.09
	1900	0.09	0.05	0.10
2000	0.09	0.05	0.11	

1. The pressure drop through the economizer is greater for 100% outdoor air than for 100% return air. If the resistance of the return air duct is less than 0.25 IWG, the unit will deliver less CFM during full economizer operation. Filter pressure drop based on standard filter media tested at velocities not to exceed 300 ft/min.

## SECTION VI: OPERATION

The following sequences of operation are based on using a single-stage air conditioning thermostat.

### COOLING SEQUENCE OF OPERATION

1. On a call for cooling, the wall thermostat sends a 24V "Y" signal to the unit. The unit contactor will close, which energizes the outdoor fan and the compressor. The 24V signal is also sent to the indoor blower motor, which will run at the selected cooling speed.
2. When the demand for cooling has been satisfied, the wall thermostat will remove the 24V "Y" signal from the unit. The contactor will open and the outdoor fan and the compressor will stop. The indoor blower has a built-in delay and will continue to run for 60 seconds after the cooling signal has been removed.

### HEATING SEQUENCE OF OPERATION

(for units which have an optional electric heat kit)

1. On a call for heating, the wall thermostat sends a 24V "W" signal to the unit. The indoor blower will then start to run at the selected heating speed. The 24V signal will also go to the sequencer(s) or relays in the electric heat kit and will turn on the electric heating elements.
2. When the demand for heating is removed, the wall thermostat will remove the "W" signal. When the 24V signal is removed from the electric heat sequencer, the heating elements will turn off. The indoor blower will continue to run for 60 seconds after the call for heat is removed.

### Electric Heat Limit Switch Operation

When the limit switch opens, the heating elements will turn off. The indoor blower will continue to run. The limit switch will automatically reset when the temperature has fallen to a normal level, at which time the heating elements will be turned on again.

**Table 15:** Thermostat Signals

Signal	State	Function
G	ON	Indoor blower instant on
	OFF	Indoor blower off after 60-second delay
W	ON	Indoor blower instant on
		Electric heat stages on (if so equipped)
	OFF	Electric heat stages off (if so equipped) Indoor blower off after 60-second delay
G & W	ON	Indoor blower instant on in heating speed
		Electric heat stages on (if so equipped)
	W OFF	Electric heat stages off (if so equipped) Indoor blower switches to continuous fan speed
G & Y	ON	Outdoor fan on
		Indoor blower instant on in cooling speed
		Compressor on
		System operates in cooling mode
	Y OFF	Compressor instant off
		Outdoor fan instant off Indoor blower switches to continuous fan speed

\* Motor program has 60 second blower off delay on all 5 speed taps.

## STARTUP

1. Check the electrical supply voltage being supplied. Be sure that it is within the specified range on the unit data plate.
2. Make sure all electrical connections are tight.
3. If unit is connected to 208 volt supply power, the control transformer must be wired accordingly.
4. Turn unit electrical power on.
5. Set the room thermostat to COOL mode and lower the desired temperature setting lower than the room temperature to create a call for cooling.
6. Measure the total system duct static and set the blower motor cooling speed appropriately per airflow performance tables.
7. If an optional electric heat kit was installed, make sure the "W" blower speed is set at or above required speed. See Table 12.
8. Make sure all units panels are in place and secured, and that an air filter is installed.

## EXTERNAL STATIC PRESSURE SETUP

To measure external static pressure:

- Measure the supply air static pressure
- Record this positive number
- Measure the return air static pressure
- Record this negative number
- Treat the negative number as a positive and add the two numbers together
- This is total system static

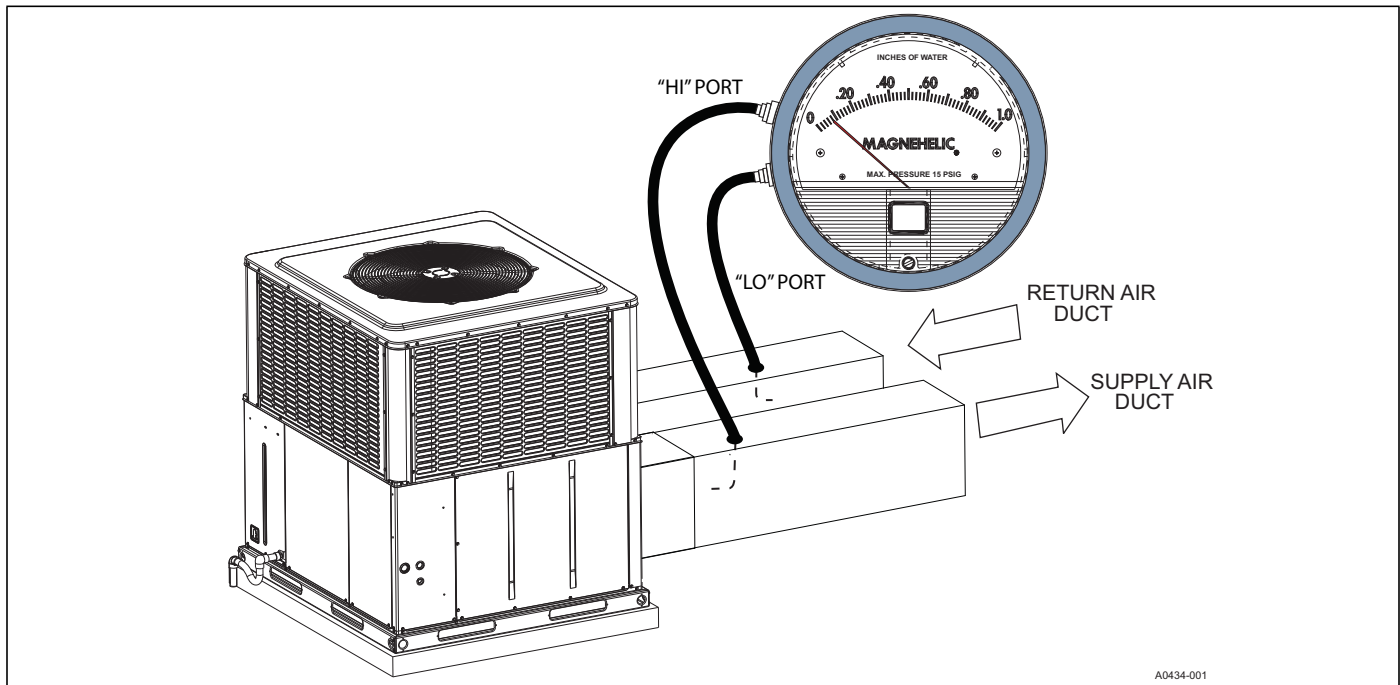

FIGURE 9: Measuring External Static Pressure

## SECTION VII: MAINTENANCE

## NORMAL MAINTENANCE

### ⚠ WARNING

Prior to any of the following maintenance procedures, shut off all power to the unit, to avoid personal injury.

Periodic maintenance consists of changing or cleaning filters and general cleaning of the outdoor coil.

**FILTERS** - Inspect once a month. Replace Disposable or clean Permanent Type as necessary. DO NOT replace Permanent Type with Disposable.

**MOTORS** - Indoor and outdoor fan motors are permanently lubricated and require no maintenance.

**OUTDOOR COIL** - Dirt should not be allowed to accumulate on the outdoor coil surface or other parts in the air circuit. Cleaning should be as often as necessary to keep the coil clean. If water is used to clean the coil, be sure that the power to the unit is shut off prior to cleaning.

### NOTICE

DO NOT use a pressure washer as coil fin damage will occur.

### ⚠ CAUTION

Exercise care when cleaning the coil so that the coil fins are not damaged. Do not permit the hot outdoor air discharge to be obstructed by overhanging structures or shrubs.

## TROUBLESHOOTING

### ⚠ WARNING

Troubleshooting of components necessarily requires opening the electrical control box with the power connected to the unit. Use extreme care when working with live circuit! Check the unit nameplate for the correct range before making any connections with line terminals.

### ⚠ CAUTION

The wire number or color and terminal designations referred to may vary. Check the wiring label inside the control box access panel for the correct wiring.

SECTION VIII: TYPICAL WIRING DIAGRAMS

# CONNECTION WIRING DIAGRAM COOLING UNIT WITH OR WITHOUT ELECTRIC HEAT

WITH RECIPROCATING COMPRESSOR  
208/230-1-60

**CAUTION - OPEN ALL DISCONNECTS  
BEFORE SERVICING THIS UNIT**

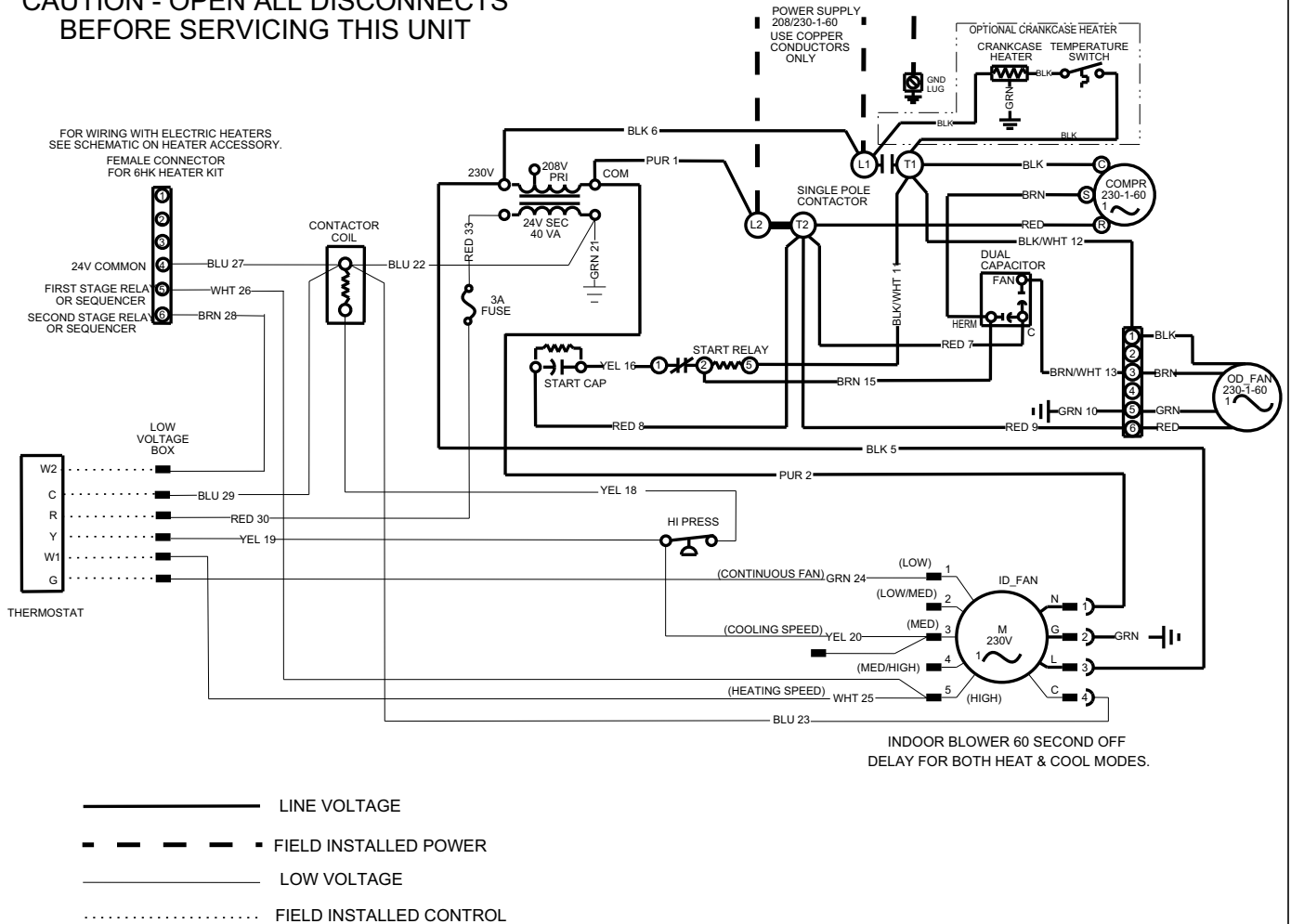

**NOTES:**

1. ALL FIELD WIRING TO BE ACCOMPLISHED FOLLOWING CITY, LOCAL AND/OR NATIONAL CODES IN EFFECT AT THE TIME OF INSTALLATION OF THE UNIT.
2. CAUTION : LABEL ALL WIRES PRIOR TO DISCONNECTION WHEN SERVICING CONTROLS. WIRING ERRORS CAN CAUSE IMPROPER AND DANGEROUS OPERATION. IF ANY OF THE WIRING, AS SUPPLIED WITH THE UNIT, MUST BE REMOVED, IT MUST BE REPLACED WITH TYPE 105 C. 600 VOLT WIRE OR EQUIVALENT CLEARLY RENUMBERED FOR IDENTIFICATION. VERIFY PROPER OPERATION AFTER SERVICING.
3. FACTORY WIRED FOR 230 VOLT SUPPLY POWER. FOR 208 VOLT, MOVE BLACK WIRES FROM THE 230 TO THE 208 VOLT TAP ON THE TRANSFORMER.
4. MOTORS ARE INHERENTLY PROTECTED.
5. SEE UNIT NAMEPLATE FOR MAXIMUM FUSE AND/OR CIRCUIT BREAKER SIZE AND MINIMUM CIRCUIT AMPACITY.
6. BLOWER MOTOR SPEED CONNECTIONS SHOWN ARE TYPICAL, BUT MAY VARY BY MODEL AND APPLICATION. SEE INSTALLATION MANUAL FOR PROPER MOTOR SPEED INFORMATION FOR EACH APPLICATION TO OBTAIN APPROX. 400 CFM/TON IN COOLING.

**FIGURE 10:** Connection Wiring Diagram - 2 to 3 Ton Models

# LADDER WIRING DIAGRAM COOLING UNIT WITH OR WITHOUT ELECTRIC HEAT WITH RECIPROCATING COMPRESSOR 208/230-1-60

**CAUTION - OPEN ALL DISCONNECTS  
BEFORE SERVICING THIS UNIT**

**NOTES:**

1. ALL FIELD WIRING TO BE ACCOMPLISHED FOLLOWING CITY, LOCAL AND/OR NATIONAL CODES IN EFFECT AT THE TIME OF INSTALLATION OF THE UNIT.
2. CAUTION : LABEL ALL WIRES PRIOR TO DISCONNECTION WHEN SERVICING CONTROLS. WIRING ERRORS CAN CAUSE IMPROPER AND DANGEROUS OPERATION. IF ANY OF THE WIRING, AS SUPPLIED WITH THE UNIT, MUST BE REMOVED, IT MUST BE REPLACED WITH TYPE 105 C. 600 VOLT WIRE OR EQUIVALENT CLEARLY RENUMBERED FOR IDENTIFICATION. VERIFY PROPER OPERATION AFTER SERVICING.
3. FACTORY WIRED FOR 230 VOLT SUPPLY POWER. FOR 208 VOLT, MOVE BLACK WIRES FROM THE 230 TO THE 208 VOLT TAP ON THE TRANSFORMER.
4. MOTORS ARE INHERENTLY PROTECTED.
5. SEE UNIT NAMEPLATE FOR MAXIMUM FUSE AND/OR CIRCUIT BREAKER SIZE AND MINIMUM CIRCUIT AMPACITY.
6. BLOWER MOTOR SPEED CONNECTIONS SHOWN ARE TYPICAL, BUT MAY VARY BY MODEL AND APPLICATION. SEE INSTALLATION MANUAL FOR PROPER MOTOR SPEED INFORMATION FOR EACH APPLICATION TO OBTAIN APPROX. 400 CFM/TON IN COOLING.

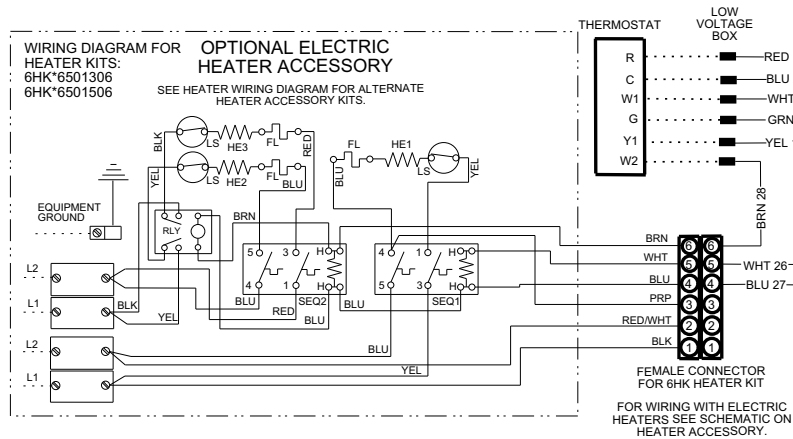
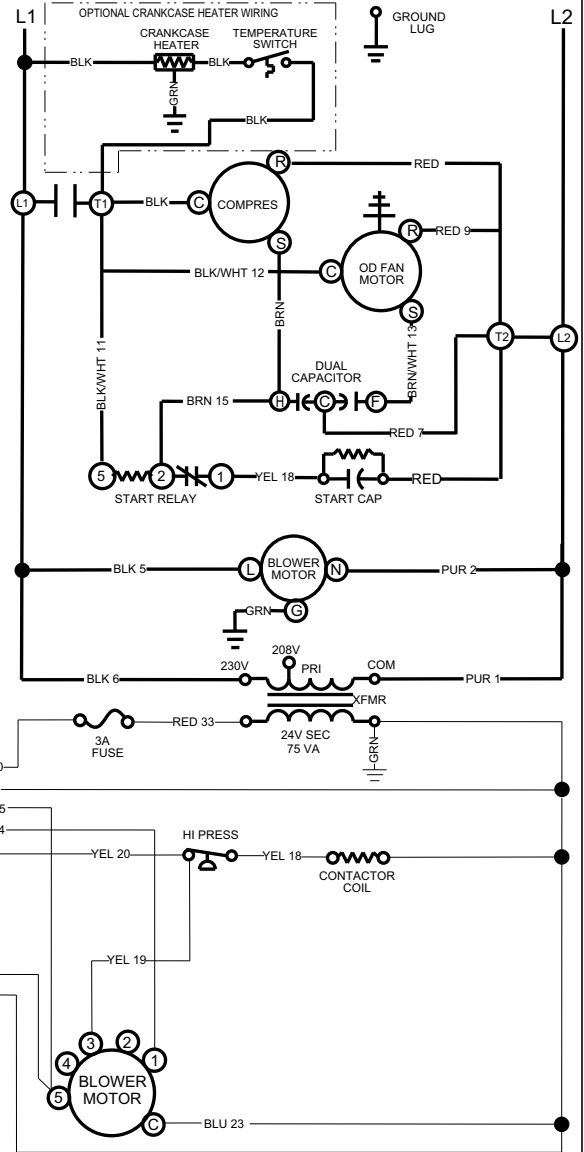

**FIGURE 11: Ladder Wiring Diagram - 2 to 3 Ton Models**

# CONNECTION WIRING DIAGRAM COOLING UNIT WITH OR WITHOUT ELECTRIC HEAT WITH SCROLL COMPRESSOR 208/230-1-60

**CAUTION - OPEN ALL DISCONNECTS  
BEFORE SERVICING THIS UNIT**

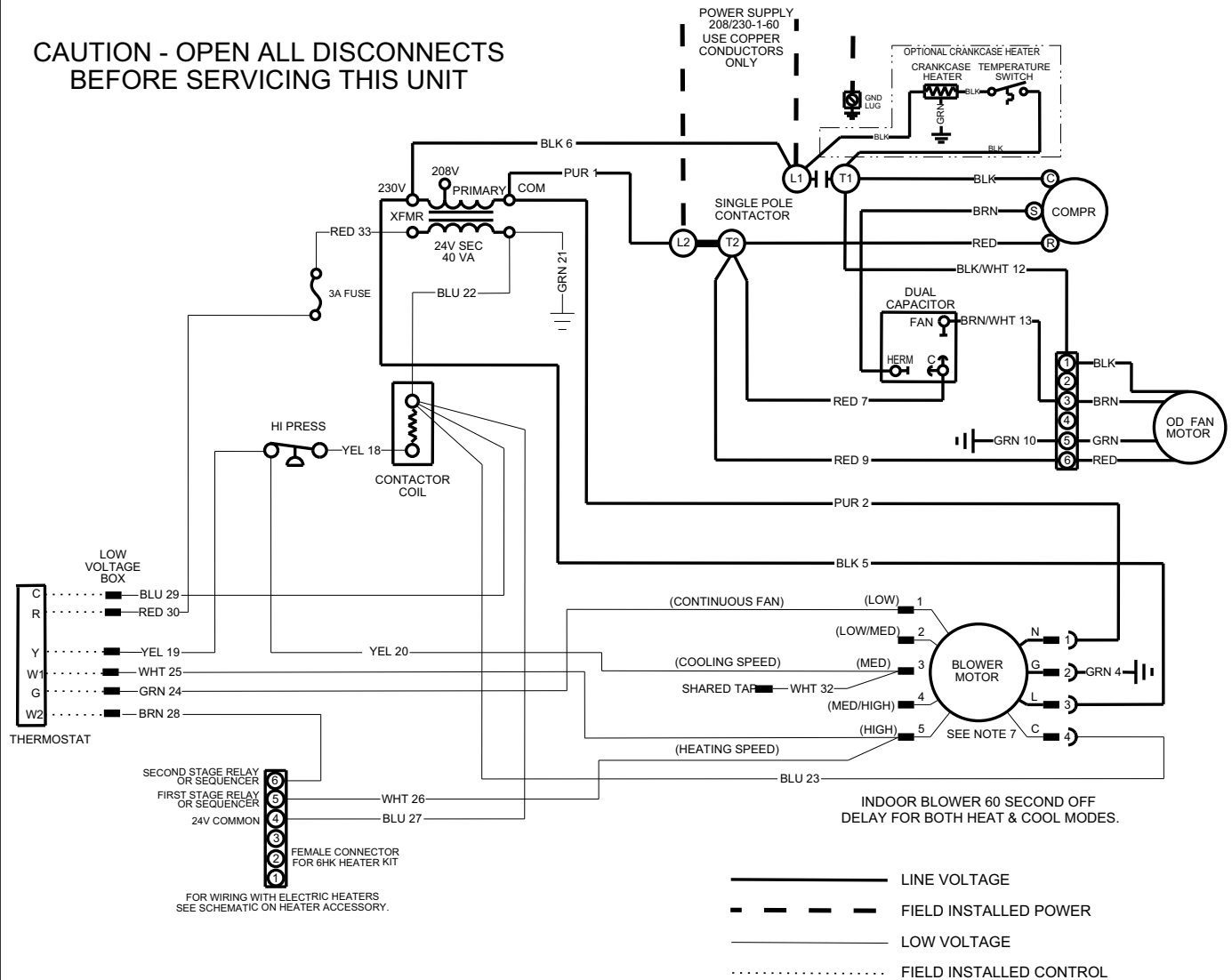

**NOTES:**

1. ALL FIELD WIRING TO BE ACCOMPLISHED FOLLOWING CITY, LOCAL AND/OR NATIONAL CODES IN EFFECT AT THE TIME OF INSTALLATION OF THE UNIT.
2. CAUTION : LABEL ALL WIRES PRIOR TO DISCONNECTION WHEN SERVICING CONTROLS. WIRING ERRORS CAN CAUSE IMPROPER AND DANGEROUS OPERATION. IF ANY OF THE WIRING, AS SUPPLIED WITH THE UNIT, MUST BE REMOVED, IT MUST BE REPLACED WITH TYPE 105 C. 600 VOLT WIRE OR EQUIVALENT CLEARLY RENUMBERED FOR IDENTIFICATION. VERIFY PROPER OPERATION AFTER SERVICING.
3. FACTORY WIRED FOR 230 VOLT SUPPLY POWER. FOR 208 VOLT, MOVE BLACK WIRES FROM THE 230 TO THE 208 VOLT TAP ON THE TRANSFORMER.
4. MOTORS ARE INHERENTLY PROTECTED.
5. SEE UNIT NAMEPLATE FOR MAXIMUM FUSE AND/OR CIRCUIT BREAKER SIZE AND MINIMUM CIRCUIT AMPACITY.
6. BLOWER MOTOR SPEED CONNECTIONS SHOWN ARE TYPICAL, BUT MAY VARY BY MODEL AND APPLICATION. SEE INSTALLATION MANUAL FOR PROPER SPEED TAP INFORMATION FOR EACH APPLICATION TO OBTAIN APPROX. 400 CFM/TON IN COOLING.

**FIGURE 12:** Connection Wiring Diagram - 3.5 to 5 Ton Models

# LADDER WIRING DIAGRAM COOLING UNIT WITH OR WITHOUT ELECTRIC HEAT WITH SCROLL COMPRESSOR 208/230-1-60

**CAUTION - OPEN ALL DISCONNECTS  
BEFORE SERVICING THIS UNIT**

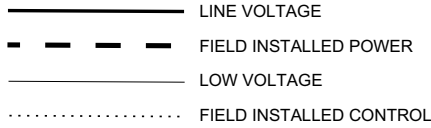

**NOTES:**

1. ALL FIELD WIRING TO BE ACCOMPLISHED FOLLOWING CITY, LOCAL AND/OR NATIONAL CODES IN EFFECT AT THE TIME OF INSTALLATION OF THE UNIT.
2. CAUTION : LABEL ALL WIRES PRIOR TO DISCONNECTION WHEN SERVICING CONTROLS. WIRING ERRORS CAN CAUSE IMPROPER AND DANGEROUS OPERATION. IF ANY OF THE WIRING, AS SUPPLIED WITH THE UNIT, MUST BE REMOVED, IT MUST BE REPLACED WITH TYPE 105 C. 600 VOLT WIRE OR EQUIVALENT CLEARLY RENUMBERED FOR IDENTIFICATION. VERIFY PROPER OPERATION AFTER SERVICING.
3. FACTORY WIRED FOR 230 VOLT SUPPLY POWER. FOR 208 VOLT, MOVE BLACK WIRES FROM THE 230 TO THE 208 VOLT TAP ON THE TRANSFORMER.
4. MOTORS ARE INHERENTLY PROTECTED.
5. SEE UNIT NAMEPLATE FOR MAXIMUM FUSE AND/OR CIRCUIT BREAKER SIZE AND MINIMUM CIRCUIT AMPACITY.
6. BLOWER MOTOR SPEED CONNECTIONS SHOWN ARE TYPICAL, BUT MAY VARY BY MODEL AND APPLICATION. SEE INSTALLATION MANUAL FOR PROPER SPEED TAP INFORMATION FOR EACH APPLICATION TO OBTAIN APPROX. 400 CFM/TON IN COOLING.

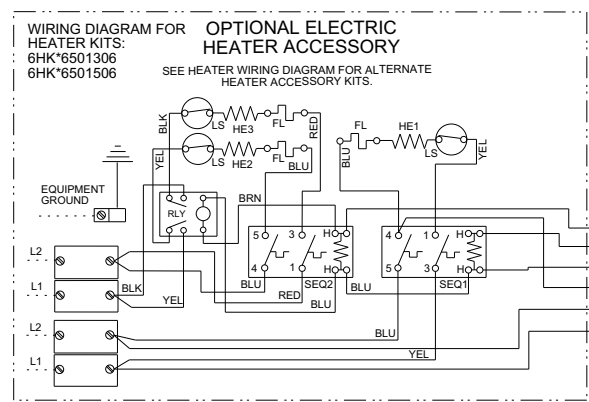
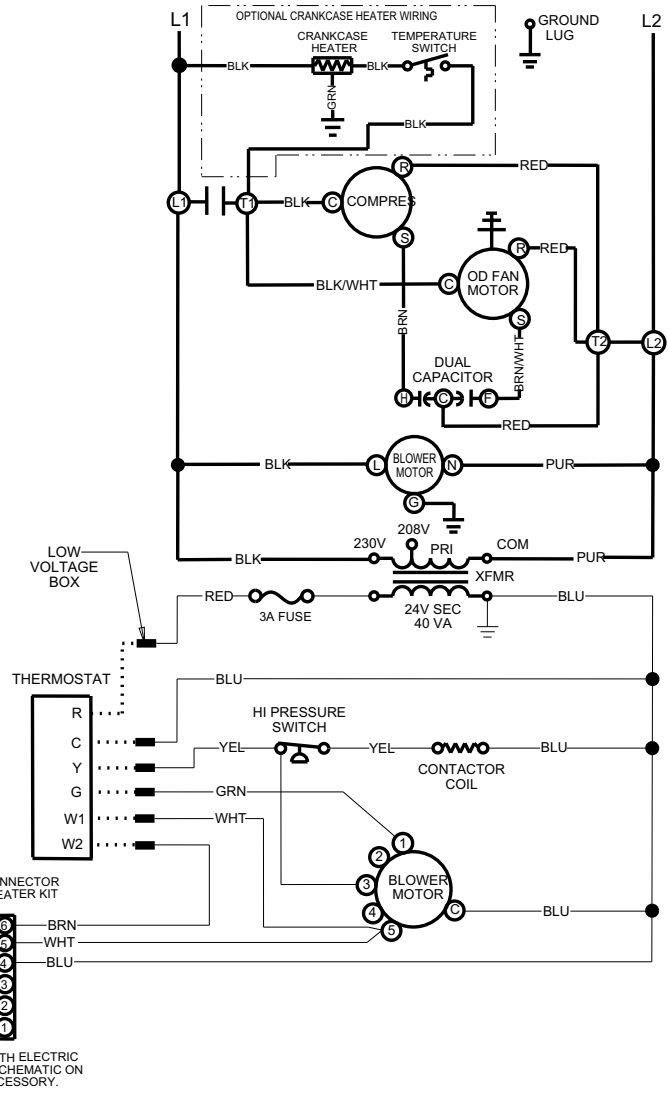

**FIGURE 13:** Ladder Wiring Diagram - 3.5 to 5 Ton Models

## R-410A QUICK REFERENCE GUIDE

### Refer to Installation Instructions for specific installation requirements

- R-410A refrigerant operates at 50 - 70 percent higher pressures than R-22. Be sure that servicing equipment and replacement components are designed to operate with R-410A.
- R-410A refrigerant cylinders are rose colored.
- Recovery cylinder service pressure rating must be 400 psig, DOT 4BA400, or DOT BW400.
- Recovery equipment must be rated for R-410A.
- **DO NOT** use R-410A service equipment on R-22 systems. All hoses, gages, recovery cylinders, charging cylinders and recovery equipment must be dedicated for use on R-410A systems only.
- Manifold sets must be at least 700 psig high side, and 180 psig low side, with 550 psig retard.
- All hoses must have a service pressure rating of 800 psig.
- Leak detectors must be designed to detect HFC refrigerants.
- Systems must be charged with liquid refrigerant. Use a commercial type metering device in the manifold hose.
- R-410A can only be used with POE type oils.
- POE type oils rapidly absorb moisture from the atmosphere.
- Vacuum pumps will **not** remove moisture from R-410A refrigerant oils.
- **Do not** use liquid line driers with a rated working pressure rating less than 600 psig.
- **Do not** install suction line driers in the liquid line.
- A liquid line drier is required on every unit.
- **Do not** use a R-22 TXV. If a TXV is to be used, it must be a R-410A TXV.
- Never open system to atmosphere when under a vacuum.
- If system must be opened for service, evacuate system then break the vacuum with dry nitrogen and replace all filter driers.

FIGURE 14: R-410A Quick Reference Guide

## NOTES

## SECTION IX: START UP SHEET

Print Form

## Residential Package Unit Cooling With Electric Heat Start-Up Sheet

Reset Form

Proper start-up is critical to customer comfort and equipment longevity

Start-Up Date  Company Name  Start-Up Technician **Owner Information**Name  Address  Daytime Phone   
City  State or Province  Zip or Postal Code **Equipment Data**Unit Model #  Unit Serial # **General Information** (Check all that apply)

<input type="radio"/> Residential	<input type="radio"/> New Construction	<input type="radio"/> Roof level	<input type="radio"/> Down flow
<input type="radio"/> Commercial	<input type="radio"/> Retrofit	<input type="radio"/> Grade level	<input type="radio"/> Side flow

**Unit Location and Connections** (Check all that apply)
 Unit is level and installed on:  Slab  Roof curb  Duct connections are complete:  Supply  Return  
 Condensate drain properly connected per the installation instructions  Condensate trap has been primed with water
**Filters**
 Filters installed Number of filters  Filter size   Filter located inside  Filter located outside
**Additional Kits & Accessories Installed** (Check all that apply)
 Refrigerant safety kit  Low ambient kit  Anti-recycle timer  Crank case heater  Filter frame kit  
 Transformer kit  Economizer  Roof curb kit  Burglar bar kit  Hail guard kit  
 Manual fresh air damper kit  Motorized fresh air damper kit
**Electrical Connections & Inspection** (Check all that apply)
 Single phase  Three phase  208 volts AC  230 volt AC  460 volts AC  575 volts AC  
 Inspect wires and electrical connections  Transformer wired properly for primary supply voltage  Ground connected  
 Low voltage present at control board "R & C" Measured voltage "R" and "C" outdoor unit control board   
 Line voltage present at disconnect Measured voltage "L1 to L2"  "L2 to L3"  "L1 to L3"   
 Compressor amperes "L1"  "L2"  "L3"  Total amperes "L1"  "L2"  "L3"   
 Single stage compressor  Two stage compressor
**Air Flow Setup / Cooling**

<b>Blower Type &amp; Set-Up</b>	<input type="radio"/> ECM	COOL <input type="radio"/> A <input type="radio"/> B <input type="radio"/> C <input type="radio"/> D
		ADJUST <input type="radio"/> A <input type="radio"/> B <input type="radio"/> C <input type="radio"/> D
		DELAY <input type="radio"/> A <input type="radio"/> B <input type="radio"/> C <input type="radio"/> D
	<input type="radio"/> X-13 <input type="radio"/> 1 <input type="radio"/> 2 <input type="radio"/> 3 <input type="radio"/> 4 <input type="radio"/> 5	
	<input type="radio"/> PSC <input type="radio"/> Low <input type="radio"/> Medium Low <input type="radio"/> Medium <input type="radio"/> Medium High <input type="radio"/> High	

Supply static (inches of water column) <input type="text"/>	Supply air dry bulb temperature <input type="text"/>	Outside air dry bulb temperature <input type="text"/>
Return static (inches of water column) <input type="text"/>	Return air dry bulb temperature <input type="text"/>	Return air wet bulb temperature <input type="text"/>
Total external static pressure <input type="text"/>	Temperature drop <input type="text"/>	Supply air wet bulb temperature <input type="text"/>

Page 1 of 2

### Refrigerant Charge and Metering Device

<input type="radio"/> R-410A <input type="radio"/> R-22	Data plate - lbs / Oz <input type="text"/>	Suction line temperature <input type="text"/>	Discharge pressure <input type="text"/>
<input type="radio"/> TXV <input type="radio"/> Fixed Orifice	Discharge line temperature <input type="text"/>	Suction pressure <input type="text"/>	Liquid line temperature <input type="text"/>
TXV# / Orifice size <input type="text"/>		Superheat <input type="text"/>	Subcooling <input type="text"/>

### Electric Heat

Electric heat kit - Model number <input type="text"/>		Serial number <input type="text"/>		Rated KW <input type="text"/>	
<input type="radio"/> Single Phase	Measured Amperage	Heater 1 <input type="text"/>	Heater 2 <input type="text"/>	Heater 3 <input type="text"/>	
<input type="radio"/> Three Phase		Heater 4 <input type="text"/>	Heater 5 <input type="text"/>	Heater 6 <input type="text"/>	
Number of elements <input type="text"/>	Measured Voltage	Heater 1 <input type="text"/>	Heater 2 <input type="text"/>	Heater 3 <input type="text"/>	
		Heater 4 <input type="text"/>	Heater 5 <input type="text"/>	Heater 6 <input type="text"/>	
Heating return air dry bulb temperature <input type="text"/>		Heating supply air dry bulb temperature <input type="text"/>		Air temperature rise <input type="text"/>	

### Clean Up Job Site

<input type="checkbox"/> Job site has been cleaned, indoor and outdoor debris removed from job site
<input type="checkbox"/> Tools have been removed from unit
<input type="checkbox"/> All panels have been installed

### Unit Operation and Cycle Test

<input type="checkbox"/> Operate the unit through continuous fan cycles from the thermostat, noting and correcting any problems
<input type="checkbox"/> Operate the unit through cooling cycles from the thermostat, noting and correcting any problems

### Owner Education

<input type="checkbox"/> Provide owner with the owner's manual
<input type="checkbox"/> Explain operation of system to equipment owner
<input type="checkbox"/> Explain thermostat use and programming (if applicable) to owner
<input type="checkbox"/> Explain the importance of regular filter replacement and equipment maintenance

### Comments and Additional Job Details