



XD 9006G  
AF3KF3SWF3HE  
02/24/2017

Simple. Smart.



## XLT Gas Oven & AVI Hood Parts & Service Manual



**CAUTION**

This appliance is for professional use by qualified personnel. This appliance must be installed by qualified persons in accordance with the regulations in force. This appliance must be installed with sufficient ventilation to prevent the occurrence of unacceptable concentrations of substances harmful to health in the room in which it is installed. This appliance needs an unobstructed flow of fresh air for satisfactory operation & must be installed in a suitably ventilated room in accordance with current regulations. This appliance should be serviced by qualified personnel at least every 12 months or sooner if heavy use is expected.

Electronic copies of this manual, Technical Specifications, Installation & Operation Manual, Architectural Drawings, & a list of International Authorized Distributors are available at: [www.xltovens.com](http://www.xltovens.com)

For use with the following XLT Gas Oven Versions:

Australia (AE) F3  
Korea (K) F3  
Standard (S) F3  
World (W) F3

For use with the following AVI Gas Hood Versions:

Standard (S) E  
World (W) E



XLT Ovens  
PO Box 9090  
Wichita, Kansas 67277

US: 888-443-2751 FAX: 316-943-2769 INTL: 316-943-2751 WEB: [www.xltovens.com](http://www.xltovens.com)



## SAFETY DEPENDS ON YOU

**DANGER**

**Improper installation, adjustment, alteration, service or maintenance can cause property damage, injury, or death. Read the installation, operating and maintenance instructions thoroughly before installing, using, or servicing this equipment.**

- Post in a prominent location instructions to be followed in the event you smell gas. This information can be obtained by consulting your local gas supplier.

**DANGER****FOR YOUR SAFETY**

**Do not store or use gasoline or other flammable liquids or vapors in the vicinity of this or any other appliance.**

- In the event a gas odor is detected, shut off the gas at the main shutoff valve immediately. Contact your local Gas Company or supplier.
- Do not restrict the flow of combustion and/or ventilation air to the unit. Provide adequate clearance for operating, cleaning, maintaining the unit & adequate clearance for operating the gas shutoff valve when the unit is in the installed position.
- Keep the area free & clear of combustible material. DO NOT SPRAY AEROSOLS IN THE VICINITY OF THIS APPLIANCE WHILE IT IS IN OPERATION.
- Ovens are certified for installation on combustible floors.
- Electrical schematics are located inside the control box of the oven & in this manual. Disconnect input power to the unit before performing any maintenance.
- This unit requires a ventilation hood. The installation must conform to local codes.
- This unit may be operated with either natural gas or liquid petroleum fuel as designated on the nameplate label located on the side of the unit.
- This unit must be operated by the same voltage, phase, & frequency of electrical power as designated on the nameplate label located on the side of the unit.
- Minimum clearances must be maintained from combustible & non-combustible construction materials.
- Follow all local codes when installing this unit.
- Follow all local codes to electrically ground the unit.
- Appliance is not to be cleaned with high pressure water.
- XLT ovens are certified for use in stacks of up to three (3) units of XLT products. Integration of other manufacturer's products into an oven stack is not recommended, & voids any warranties. XLT Ovens assumes no liability for mixed product applications.
- Failure to call XLT Customer Service at 1-888-443-2751 prior to contacting a repair company voids any & all warranties.
- PLEASE RETAIN THIS MANUAL FOR FUTURE REFERENCE.

XLT Ovens has spent millions of dollars designing and testing our products as well as developing Installation & Operation Manuals. These manuals are the most complete and easiest to understand in the industry. However, they are worthless if they are not followed.

We have witnessed store operators and building owners lose many thousands of dollars in lost revenue due to incorrect installations. We highly recommend you follow all instructions given in this manual as well as follow best practices in plumbing, electrical, and HVAC building codes.

**Definitions & Symbols**

A safety instruction (message) includes a “Safety Alert Symbol” & a signal word or phrase such as **DANGER**, **WARNING** or **CAUTION**. Each signal word has the following meaning:

**DANGER**

Indicates a potentially hazardous situation that, if not avoided, can result in serious injury or death.

**HIGH  
VOLTAGE**

This symbol indicates high voltage. It calls your attention to items or operations that could be dangerous to you & other persons operating this equipment. Read the message & follow the instructions carefully.

**WARNING**

Indicates a potentially hazardous situation, that if not avoided, can result in cuts or being crushed. It calls your attention to items or operations that could be dangerous to you & other persons operating this equipment.

**CAUTION**

Indicates a potentially hazardous situation, that if not avoided, can result in minor to moderate injury or serious damage to the product. The situation described in the CAUTION may, if not avoided, lead to serious results. Important safety measures are described in CAUTION (as well as WARNING), so be sure to observe them.

**NOTE**

Notes indicates an area or subject of special merit, emphasizing either the product’s capability or common errors in operation or maintenance.

**TIP**

Tips give a special instruction that can save time or provide other benefits while installing or using the product. The tip calls attention to an idea that may not be obvious to first-time users of the product.



## Warranty - US and Canada

Rev G

Approval Date: 11/01/2016

XLT warrants Version F ovens manufactured after January 1, 2016 to be free from any defect in material and workmanship under normal use for seven (7) years from the date of original purchase by the end user, and further warrants main fan blades, conveyor shafts, and conveyor bearings for ten (10) years. XLT further warrants all ovens to be free from rust for ten (10) years from the date the equipment is originally purchased. XLT warrants Version E hoods manufactured after December 1, 2015 to be free from any defect in material and workmanship under normal use for five (5) years from the date of original purchase by the end user purchaser. In the event of a part failure, XLT will furnish a replacement part and pay for all labor associated with the replacement of the part. If upon inspection XLT determines that the part is not defective, all incurred cost will be the responsibility of the end user purchaser. This warranty is extended to the original end user purchaser and is not transferable without prior written consent of XLT. Damages are limited to the original purchase price.

### DUTIES OF THE OWNER:

- The owner must inspect the equipment and crates at time of receipt. Damage during shipment is to be immediately reported to the carrier and also to XLT
- The equipment must be installed and operated in accordance with the written instructions furnished with the unit
- This warranty shall not excuse the owner from properly maintaining the equipment in accordance with the written instructions furnished with the unit
- A copy of the "Initial Start-Up Checklist" must be filled out and returned to XLT when the unit is initially installed, and/or when the unit is removed and installed in another location
- The gas, electric, and HVAC utilities must be connected to the oven and installed by locally licensed contractors
- Failure to contact XLT Ovens prior to contacting a repair company for warranty work voids any and all warranties

### WHAT IS NOT COVERED:

- Freight damage
- Overtime charges
- Any part that becomes defective because of utility services (power surges, high or low voltages, high or low gas pressure or volume, contaminated fuel, or improper utility connections)
- Any part that becomes defective because of moisture and/or other contaminants
- Conveyor belts
- Filters
- Exhaust Fans
- Light Bulbs
- Painted or Powder Coated surfaces
- Normal maintenance or adjustments
- This warranty shall not apply if the equipment or any part is damaged as a result of accident, casualty, alteration, misuse, abuse, improper cleaning, improper installation, improper operation, natural disasters, or man-made disasters

### CLAIMS HANDLED AS FOLLOWS:

Should any such defect be discovered, XLT must be notified. Upon notification, XLT will arrange for necessary repairs to be made by an authorized service agent. Denial of services upon the arrival of an authorized service agent will release XLT of any and all warranty obligations.





## Warranty - International

Rev J

Approval Date: 11/01/2016

When purchased through an Authorized International Distributor, XLT warrants Version F Ovens and Version E Hoods to be free from any defect in material and workmanship under normal use. The Authorized International Distributor will repair XLT products during the warranty period. This warranty is extended to the original end user purchaser and is not transferable without prior written consent of the Authorized International Distributor. Damages are limited to the original purchase price. Products purchased by any other means other than an Authorized International Distributor will have no warranty. This warranty applies to areas outside the 50 United States of America and Canada.

### DUTIES OF THE OWNER:

- The owner must inspect the equipment and crates at time of receipt. Damage during shipment is to be immediately reported to the carrier and also to the Authorized International Distributor.
- The equipment must be operated in accordance with the written instructions furnished with the unit.
- This warranty is not valid unless equipment is installed, started, and demonstrated under the supervision of the Authorized International Distributor.
- This warranty shall not excuse the owner from properly maintaining the equipment in accordance with the written instructions furnished with the unit.
- A copy of the "Initial Start-Up Checklist" must be filled out and returned to the Authorized International Distributor when the unit is initially installed, and/or when the unit is removed and installed in another location.
- The gas, electric, and HVAC utilities must be connected to the equipment and installed by locally licensed contractors.
- The Authorized International Distributor must be contacted for service. Failure to contact the Authorized International Distributor prior to contacting a repair company for warranty work voids any and all warranties.

### WHAT IS COVERED (Subject to local market conditions):

- 5 year labor – Extensions may be available and charges may apply
- 5 year parts – Extensions may be available and charges may apply
- 5 years parts and labor on: oven fan blade, structural welds, conveyor shafts, conveyor bearings, rusted materials in ovens

### WHAT IS NOT COVERED (Subject to local market conditions):

- Freight damage
- Any part that becomes defective because of utility services (power surges, high or low voltages, high or low gas pressure or volume, contaminated fuel, or improper utility connections)
- Any part that becomes defective because of moisture and/or other contaminants
- Conveyor belts
- Filters
- Exhaust fans
- Light bulbs
- Painted or Powder Coated surfaces
- Rusted materials in hoods
- Normal maintenance or adjustments
- This warranty shall not apply if the equipment or any part is damaged as a result of accident, casualty, alteration, misuse, abuse, improper cleaning, use of caustic/acidic chemicals, improper installation, improper operation, natural disasters, or man-made disasters

### CLAIMS HANDLED AS FOLLOWS:

Should any such defect be discovered, the Authorized International Distributor must be notified. Upon notification, the Authorized International Distributor will arrange for necessary repairs.

7781 W Kellogg Drive 67208-2003 - PO Box 8080 67277-0080 - Wichita, Kansas  
Voice (316) 843-2751 - (888) 443-2751 - Fax (316) 843-2789  
www.xltovens.com



This page intentionally left blank.

Responsibility	XLT/Service Company	Owner/ Contractor
<b>Site Survey: Verify electric and gas meter/regulator sizes</b>	X	
<b>Supply wiring from TS1 #R3, R4, R5 to exhaust fan</b>		X
<b>Supply (1) single phase 230 volt 10 amp circuit from breaker panel to XLT Hood</b>		X
<b>Assembly of new hood per XLT Installation &amp; Operation Manual</b>		X
Suspend XLT Hood from ceiling		X
Install new exhaust fan on roof		X
Supply power to XLT Hood		X
Install Duct Cover or Valance above XLT Hood		X
<b>Assembly of new ovens per XLT Installation &amp; Operation Manual</b>		
Stands assembled and set in place	X	
Ovens moved and stacked with proper lifting equipment	X	
Assemble shrouds & brackets to XLT Oven/Hood	X	
<b>Connecting fuel to XLT products</b>		
Install piping and drip legs		X
Weld ducting to XLT Hood		X
Check for leaks		X
Install flexible gas hoses	X	
Connect electrical supply	X	
<b>Connection may require Permit and Code Inspections</b>		X
<b>Relocate Make-Up-Air to enter the room at the ends of the ovens</b>		X
<b>Start-up per XLT Installation &amp; Operation Manual:</b>	X	
Gas pressure/leak testing, hood/oven functions, adjust as necessary	X	
Start-Up Checklist must be submitted to XLT to validate Warranty		X

This manual, which contains an illustrated parts breakdown, has been prepared as an aid in understanding how the unit operates, how to diagnose problems, and order parts for the equipment. All of the parts, listed in the parts breakdown, are manufactured with the same precision as the original equipment.

XLT parts and service providers are available worldwide. There are authorized service providers located in the principle cities of the United States. There are also authorized Distributors located throughout the world.

The Theory of Operation section describes how the unit operates. An understanding of normal operation will greatly aid diagnosis and troubleshooting. The Troubleshooting section asks simple yes or no questions. The next question or statement entirely depends upon the previous answer. It will lead to the solution of a problem in the most efficient way. The illustrated parts section identifies the various sub-assemblies and detailed parts which make up the equipment, as well as the part number. An explanation of how to order parts is included.

This manual is designed to supplement the Installation & Operation Manual provided with the unit when new. Please refer to it for descriptions, dimensions, weights, electrical requirements, maintenance schedules, and certifications.

XLT Ovens wants you to be totally satisfied with every aspect of owning & using your oven & hood. Your feedback, both positive & negative, is very important to us as it helps us understand how to improve our products & our company. Our goal is to provide you with equipment that we can be proud to build & you can be proud to own.

To receive technical support for the oven or hood you purchased, XLT has qualified customer service personnel that can provide assistance on any type of XLT oven or hood equipment problem you may experience. Customer Service is available 24/7/365 at 888-443-2751 or visit [www.xltovens.com](http://www.xltovens.com).



**DANGER**

Repairs of all appliances & ventilation exhaust hoods should only be performed by a qualified professional who has read & understands these instructions & is familiar with proper safety precautions. Read this manual thoroughly before installing or servicing this equipment.

### Save this Manual

This document is the property of the owner of this equipment.

XLT Ovens reserves the right to make changes in design & specifications, and/or make additions to or improvements to its product without imposing any obligations upon itself to install them in products previously manufactured.

All Right Hand & Left Hand designations in this manual are from the point of view as if standing directly in front of the glass sandwich door.

Warning & Safety Information.....	2
Warranty.....	4
Installation Responsibilities .....	7
General .....	8
Oven Theory of Operation .....	10
Hood Theory of Operation .....	16
Oven Troubleshooting.....	19
Hood Troubleshooting.....	20
Oven Service Procedures.....	21
Hood Service Procedures .....	28
Oven Parts .....	31
Hood Parts .....	61
Oven Schematics .....	64
Hood Schematics.....	74
Notes.....	77

**For maintenance procedures, please refer to the XLT Installation & Operation Manual.**

Revision History Table		
Revision	Comments	Date
E	Updated US and International Warranties on Pg. 4 and 5, Added Australia Shutter Information on Pg.25, Updated Oven and Hood Theory of Operation Pg 10-18, Updated World Control Box Assembly Pg 46-50, Updated Hood Control Box Pg 54-55, Updated Oven and Hood Schematics and Updated Images To Reflect Decals Moving	11/01/2016
F	Added VFD Programming Pg 22 & Pg 23, Removed “Machine” From Oven Control Pg 10 & Pg 13, Updated Manual To Version F1 on Cover, and Added Korea Information.	01/10/2017
G	Updated Manual To Version F3 on Cover, Added AL To Pg 10, Added V3 To Pg 15, Added Australia Control Box Information Pg 54-59, Updated All Oven Schematics, and Added Australia Schematics.	02/24/2017

When the main power on the Large User Interface (LUI) is turned on:

1. The Oven Fan Motor (M1) located in the Back Wall will run.
2. The Fan (M3) located on the Control Panel will run.
3. The Large User Interface (LUI) will display actual temperature until set point is reached.
4. The Large User Interface (LUI) will display belt time.
5. The burner will ignite.
6. The conveyor belt will move.

The first part of the Theory of Operation explains how electrical power is delivered to the oven and initial sequences when the main power on the Large User Interface (LUI) is turned on. The remainder of the Theory of Operation section explains the function of components in alphabetical order. These components are also listed on the schematic.

- Line voltage for Standard Ovens is assumed to be 120 VAC, 60 Hz.
- Line voltage for World & Australian Ovens is assumed to be 230 VAC, 50 Hz.

Power originates at the electrical connection on the wall. Line voltage is then carried into the oven through the power cord to the Terminal Strip (TS1). The Neutral line is connected to TS1-1L and L1 is connected to TS1-2L. From the other side of the TS1, power is carried through the High Limit Switch (S3) and splits at Circuit Breaker (CB1) to go to both the Power Supply (PS) and Oven Fan Motor Relay (R1) or the Frequency Drive (VFD). The PS then converts the line voltage into 24 VDC that is used to power TS2-1 through TS2-3 positions at +24 VDC and TS2-8 through TS2-10 positions at -24 VDC. From TS2, +24 VDC is distributed to Gas Valve (V2) High/Low flame and Oven Controls (OMC1) and (OMC2 if equipped) P10-4 via CB4/5 and P4-2. These wires are live as long as oven is connected to power on wall.

When the oven is turned on, a relay inside the OMC closes between P4-2 & P4-3, sending 24 VDC out of P4-3 to TS2-6R which distributes power to Flame Sense (FS), the FPPG Fan (M3), the Ignition Control (IC) terminal 2 and call for heat IC terminal 4 via the Centrifugal Switch (S2) on Oven Fan Motor (M1). The IC then starts the trial for ignition. The OMC P11-1 will also send low voltage to the R1 or the Oven Fan Motor Frequency Drive (VFD World and Australia Only). When R1 closes, line voltage is applied from R1-2 to M1. OMC P11-2 will ground V2 to open the high flame valve. If the oven is used with an AVI Hood the jumper at Molex Connector (MC3) is removed and +24 VDC is sent to the hood. A relay in the hood will control the oven operation as long as the LUI had the Remote Switch Function turned on.

**AL** - The Ignition Alarm is optional. When the IC goes into ignition lockout, when pin 1 is grounded it then causes the alarm will began flashing and beeping. The alarm receives +24 VDC from the TS2-1R on the master control box and if it is a dual burner TS3-1R on the secondary box. Cycle power on the oven to reset alarm.

**CAP** - The Capacitor is physically mounted inside the Control Box but wired to the externally mounted M1. The M1 is a Permanent Split Capacitor (PSC) motor. PSC means a capacitor motor in which the starting capacitor and the auxiliary winding remain in the circuit for both starting and running. The CAP is a 30.0  $\mu\text{F}$  +/- 6% 370VAC/B 50/60 Hz.

**CB** - Circuit Breakers are used to protect electrical components. The current value is printed on the front of all breakers. If a CB is tripped, eliminate the cause and press the front to reset.

**CS** -The Current Sensor detects electrical current (AC) in a wire, and generates a signal proportional to it. The generated signal is analog voltage and then sends it to the LUI. This monitors the condition of the oven fan motor (Standard Ovens Only).

**FLT 1** - This is an inline filter used in world ovens. The filter is placed in series with the line voltage being supplied to the oven. The filter is used to reduce Electromagnetic Interference created by our equipment and back-feeding it into other appliances. The EMC filter in the gas oven and the EMI filter in the electric oven use capacitors to inhibit direct current while permitting alternating current. The filters also use inductors which redirect high voltages and high frequencies by dissipating them to ground. Filters should always be grounded to the oven.

**FS** - The Flame Sensor consists of a plastic housing and a flame detector mount. The FS utilizes 24 VDC which originates at TS2-5L. When the oven is turned on this terminal receives voltage. The negative line is supplied via the TS2-9L. From the connector a blue wire sends a 6.75  $\mu\text{A}$  signal to IC-10. The minimum signal to maintain operation is 1.0  $\mu\text{A}$ . When flame is present, the sensor visually looks at the flicker rate and the UV characteristics of the flame. If either of these do not appear the sensor will not send current to the IC. The ignition will continue thru its process until lockout.

**IC** - The Ignition Control is powered by 24 VDC. The IC has two +24 VDC inputs; 1) from the OMC via the TS2, and 2) a call for heat from the OMC via S2 which is mounted in M1. This will turn a green LED on indicating IC has power and a call for heat. When the IC receives a call for heat, it initiates a pre-purge lighting sequence. A red LED will blink once after about 2-3 seconds to give notification that the lighting sequence has started. After about 30 seconds, two events occur; 1) a high-voltage electrical signal will be sent to the Spark Rod (SR) from the Spark Terminal, and a VDC (+) will be sent from terminal IC6 to Gas Valve On/Off (V1). The high voltage jumps across a gap in the SR creating a spark that can be heard, although the IC only produces this spark for four (4) seconds. The V1-V2 valve will open, allowing fuel to flow into the burner. When the two events occur, fuel flow and spark, ignition will occur. When flame is sensed by the FS, a DC signal is sent to IC10. The IC uses this DC current to prove ignition. A minimum of 1.0  $\mu\text{A}$  DC is required to maintain operation. When the burner lights, the LED indicator will be green. If the Burner fails to light, the IC will reattempt ignition three (3) more times before the LED will flash three (3) times, repeatedly, going into lockout.

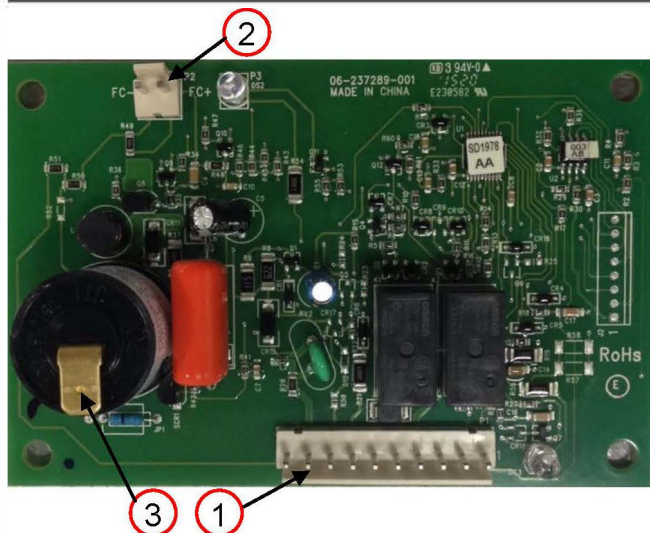

1) P1

- 1) Not Used-Alarm
- 2) +24 VDC In
- 3) Not Used-Manual Reset
- 4) Call For Heat
- 5) Ground In
- 6) +24 VDC Sent To V1
- 7) Not Used-Digital Output
- 8) Not Used
- 9) Burner Ground
- 10) Signal Wire To Flame Sensor

2) P2- Not Used

3) Spark Wire

**LR**– The Line Reactor is used in all world ovens. It is an inductor wire between the incoming AC power source and the VFD. It is used to filter out spikes of current and reduce harmonics.



1) P1- Not Used

2) P2- RS-485 Cable To OMC1

1) +5V

2) 485-

3) 485+

4) Ground

3) P3- RS-485 Cable To OMC2

1) +5V

2) 485-

3) 485+

4) Ground

4) P5- Ground

5) P17- Not Used

**LUI** - The Large User Interface is powered by the OMC by the RS 485 cable. The main power button is located on the front face of the LUI. The conveyor(s) and temperature of the oven is controlled through the LUI. You can change the factory settings for the oven size, VFD/No VFD, cool down mode, and Gas/Electric, etc. For a Standard Oven it will also display the main fan amps. The LUI will display error messages and maintenance alarms. There are 12 menu presets for predetermined time and temperature settings. The screen can be locked to prevent unwanted mischief.

**M1** - The Main Motor for standard ovens is a PSC, single phase, capacitor run motor and has an internal S2. The motor is dual voltage and reversible. The voltage to power the motor comes from the R1 terminal #2. For world ovens M1 is a 3 phase inverter rated motor with an internal S2. It gets power from a variable frequency drive which is then turned on by the OMC. The main motor will continue to operate for approximately 30 minutes or until the oven temperature is less than 225 degrees Fahrenheit after the oven is turned off. There are no user serviceable parts in the motor, and the bearings are permanently lubricated.

**M2** - The Conveyor Motor is a brushless 24 VDC gear motor. The motor receives current from the OMC through three (3) wires; 1) A black or “W” phase, 2) a white or “V” phase, and 3) a red or “U” phase. They carry between 18 to 24 VDC. Each wire is energized by the OMC in sequence to provide power to the individual stator coils which, in turn, provide motor rotation. To determine the rotor position and send this position to the controller, three (3) Hall Effect switches are utilized. They read the rotational information from a disc mounted on the rotor assembly. This information is transmitted to the OMC by three (3) wires; 1) an orange “U” phase pole signal output, 2) a green “V” phase pole signal output, and 3) a green/white “W” phase pole signal output. These are located in a plug that inserts into the OMC1 or OMC2. There are two (2) additional wires in this plug; 1) a purple wire which is supply voltage for the pole sensor, and 2) a gray wire that is ground. The OMC, using an internal logic circuit, energizes the stator coils to provide proper rotation and sets the energization (phase) timing to obtain the desired belt speed set on the controller. The motor drives an integral gear box that reduces the motor output speed to give the correct travel time to the conveyor belt. The integral gear box is sealed and permanently lubricated with grease. The ratio is 1/200. This motor contains no serviceable parts. The OMC will detect if the conveyor belt has a jam by monitoring the rotor signal. If the signal falls more than 25% below the expected rate a jam is detected. This action will stop the conveyor and display an alarm on the LUI. To reset the alarm press and hold “Time” key for 10 seconds.

**M3** - The Flow Path Pressure Generating fan supplies combustion air for the Burner. It is controlled by turning on and off the main power button. A filter is provided to ensure clean air.

1) P1- Not Used– Digital Input

2) P2- RS-485 Cable To LUI

1) +5V

2) 485-

3) 485+

4) Ground

3) P4

1) +24 Remote Switch

2) +24 Power (In) Switch

3) Relay +24 Switched (Out)

4) P5- Elan Programming

5) P6- Elan Serial Port

6) P7- Jumper For OMC 1 or 2

7) P8- Thermocouples

1) Red (-)

2) Yellow (+)

8) P9- Conveyor Motor

1) Motor SA

2) Motor SB

3) Motor SC

4) Hall +5V

5) Hall HC+

6) Hall HB+

7) Hall HA+

8) Ground

9) Not Used

9) P10

1) Current Sensor

2) Current Sensor

3) 24 VDC(-) Main Power

4) 24 VDC(+) Main Power

10) P11

1) +24 VDC To Main Fan Motor

2) -24 VDC Ground to Gas Valve V2

**OMC** - The Oven Control reads selections or parameters from the LUI. It holds the logic for the conveyor controls and the temperature controls. The OMC will turn on or off V2, start and stop M1, send the call for heat signal, reads the thermocouple and monitor the current sensor.

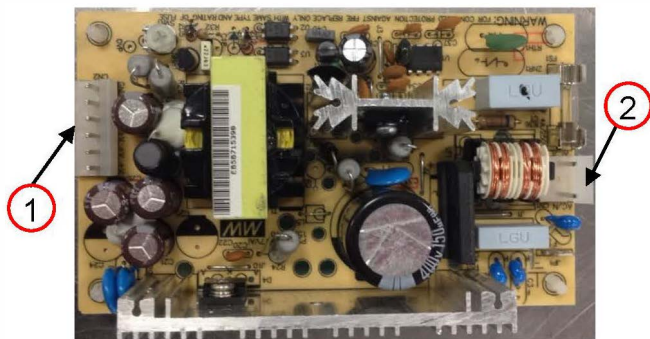

- 1) CN2- 24VDC
  - 1) +24 VDC Main Power To OMC
  - 2) +24 VDC
  - 3) +24 VDC
  - 4) -24 VDC Ground To IC
  - 5) -24 VDC Ground To IC
  - 6) -24 VDC Ground To TS2
- 2) CN1- Line Voltage
  - 1) Neutral
  - 2) Not Used
  - 3) Line Voltage

**PS** - The Power Supply rectifies line voltage to 24 VDC, and supplies power to the OMC, IC, FS, and S2. A 4 amp fuse is used to provide over current protection, which is mounted on the PS itself. There are no other fuses used anywhere else.

**PU** - The Pick-Up is physically mounted within M2 and utilizes hall effect technology integral to the M2 to monitor the rotation speed. The hall effect signal is transmitted to the OMC, which converts it into linear travel speed of the conveyor.

**R1** - The Oven Fan Motor Relay is used as a remote switch to handle the higher amp load of M1.

**S2** - The Centrifugal Switch is a SPDT switch physically mounted inside M1. When M1 comes up to full speed, S2 closes and sends a 24 VDC signal to the IC. It functions as a safety feature to prevent burner operation if the M1 fails to rotate.

**S3 - Standard Ovens**- The High Limit Switch for standard ovens is a bi-metal, NC, SPST switch physically mounted in the side panel of the Bake Chamber. Its purpose is to provide fail safe operation. If the temperature of S3 exceeds 600°F, it opens and interrupts line voltage to all components when the switch opens.



- 1) Thermocouple 1 (+) - Yellow
- 2) Thermocouple 1 (-) - Red
- 3) Thermocouple 2 (-) - Red
- 4) Thermocouple 2 (+) - Yellow
- 5) COM- Line Voltage
- 6) N.O.- Switched Line Voltage
- 7) L2- High Limit Power
- 8) L1- High Limit Power

**S3 - World Ovens**- The High Limit Switch for world ovens is an electronic, SPST switch physically mounted on the side panel of the Bake Chamber. Its purpose is to provide fail safe operation. If the actual oven temperature exceeds 650°F the yellow LED will not illuminate. A red LED will flash and S3 opens to interrupts line voltage to all components. There are two (2) thermocouple inputs to this device. If the delta exceeds 20° C between the thermocouples, a yellow LED and Red will alternate flashing and S3 closes.

**SR** - The Spark Rod consists of a copper-clad metal mounting plate, and an electrode encapsulated

in ceramic insulation. The insulated electrode has a 1/4" male spade welded to it. This spade connects to the Spark Terminal on the IC via a spark wire. The end of this rod is positioned near the burner tube in such a way so as to create a small gap. When the high-voltage signal from the IC reaches the gap, it is forced to jump the gap resulting in a spark.

**T/C** - The thermocouple is a type K. It consists of two different conductors that produce a voltage proportional to a temperature difference between either end of the pair of conductors. The T/C is connected to P8 Terminals 1 & 2 on the OMC. The millivolt signal is used to display the actual temperature.

1) TS1- Terminal Strip

- 1L) Neutral In
- 2L) L1 In
- 3L) Not Used
- 4L) S2 Signal Out
- 1R) Neutral Out
- 2R) L1 Out
- 3R) Not Used
- 4R) S2 Signal In

2) TS2- Terminal Strip

1L) Power V2 and SRC	1R) Not Used
2L) Not Used	2R) Power 2nd OMC
3L) +24 VDC In	3R) 24 VDC Power To OCM1
4L) Not Used	4R) Not Used
5L) Power IC and FS	5R) M3 (+)
6L) Power S2 24 VDC	6R) Power To Relay COM
7L) SRC	7R) Cooldown Switch
8L) COM For V1	8R) M3 (-)
9L) Flame Sensor (-)	9R) -24 VDC
10L) Ground To VFD	10R) Ground

**TS 1 & 2** - These are terminal strips, that serve as a connection point for wires.

**V1-V2** - The Gas Valve consists of two (2) solenoid valves. V1 is open continuously during burner operation, regardless of either actual or set-point temperature values. V2 is a Hi/Low valve, and is controlled by P11-2 on the OMC. There are two (2) brass fuel pressure testing ports; one for incoming pressure, and one for high-bias. The upper port is used for incoming pressure, while the lower port is used for high-bias pressure. There is a regulator on the side of the valve to adjust the High-bias pressure.

**V3** - The shut-off valve is only in the Australia Control box. When M1 is receiving power from the VFD, the relay at VFD-R1 closes sending +24 VDC to V3. Which opens the valve.

**VFD** -The Variable Frequency Drive converts 50 Hz power into 60 Hz power so the ovens fan can run at the proper RPM's. The VFD converts the AC supply voltage to DC and then converts the DC to a suitable three-phase frequency source for M1. The VFD is turned on via the OMC P11-1. A complete VFD manual can be found at [www.xltovens.com](http://www.xltovens.com).

1) Incoming Power

- 1) Neutral
- 2) Line Voltage
- 3) Not Used
- 4) Ground

2) Not Used-VFD Relay

3) Digital Inputs

- 1) Stop Function
- 2) Start / Run
- 3) Not Used
- 4) COM To TS2
- 5) Not Used
- 6) Not Used

4) Exhaust Fan Power

- 1) Power To Motor
- 2) Power To Motor
- 3) Power To Motor
- 4) Not Used
- 5) Not Used

5) ModBus Comm

When any one of the three oven switches on the Hood User Interface (HUI) are touched (capacitive touch);

1. The Exhaust Fan Motor (M1) located on the roof will run.
2. The ovens associated with the corresponding switches will turn on.

The first part of the Theory of Operation explains how electrical power is delivered to the hood and initial sequences when the HUI switch is turned on. The remainder of the Theory of Operation section explains the function of components in alphabetical order. These components are also listed on the schematic.

Power for the hood originates at the building's electrical service panel. A total of four (4) circuits are required; circuit (1) is a single phase high voltage circuit for VFD/Fan circuit that connects to TS 1 terminals 1 & 2, and circuit (2, 3, and 4) are single phase low voltage minimum 20A circuits for each oven that connects Hood Machine Control (HMC) P3 1, 5, and 9 for line side, and neutral will connect at 3, 7, and 11. Lights piggyback off the top oven power P3 terminal 9 on HMC.

HUI mounted on the hood controls lighting, VFD activation, Make Up Air (MUA) activation and oven function. When HUI Light Switch is touched a relay is closed and voltage will go to lights. When ovens are installed with a hood, the Switch Relocation Cord (SRC) effectively eliminates the main switch located on the oven and transfers control to HUI switches on the hood. When HUI switches are touched a communication signal is sent to the VFD via ModBus signaling it to turn on to a set frequency, at the same time when HUI2 is activated a relay will allow line voltage to be carried through the Switch Relocation Cord (SRC) to the oven activating it. When HUI2-4 are activated the MUA will turn on. The VFD has a built in power supply that is wired to terminal 01 this puts the VFD in run mode so whenever a power loss is sensed the VFD will start back up in run mode once power is restored. The NO switch in the fire alarm system in the building needs to be connected to TS 1 terminals 9 & 10. When the alarm is activated 24 VDC from TS1 9 will return from the fire alarm system to TS1 10 then to HMC P8 to turn off lights, cooling fans, HUI, MUA, shut down ovens and making both relays R1 & R2 switch from NC to NO, causing the VFD to run at 60 Hz.

**CB** - Circuit Breakers are used to protect electrical components. If a CB is tripped, eliminate the cause and press the front to reset.

**HUI** – Hood User Interface contains the factory settings so that the hood will operate with the correct hertz when the correct oven size and number of ovens are selected. The factory settings also contain a selection for a VFD, Non VFD, type of MUA activation, and for a World installation. A beeping sound and the display will flash if an alarm occurs. An error message will display at top of screen on HUI. Touching the “I” button will give a brief description of how to correct the error (see Figure 1). Touching the “Light Bulb” button will turn the light on and off inside the hood.

Touching the “Silver Square” buttons will turn each oven on or off and sequence the operation of the VFD and the MUA circuits. RS485 cable supplies power and communication between the HUI and HMC.

**HMC** – The Hood Machine Control is a printed circuit board that has all the relays to control these functions; oven activation SRC, MUA activation, VFD activation, monitors the air proving switches, and lighting activation. The HMC receives a continuous 24 VDC power source provided the CB1 breaker is on. This component also has independent relays to control oven power for fire suppression. If a signal from the fire system is received the oven(s) and lighting power is discontinued and the VFD will run at full speed. For a World installation, sail switch monitoring is available just by answering some questions through factory mode programming. The HMC will also program the PowerFlex 4M VFD each time the CB1 breaker is turned on. ModBus communication is used to change the frequency the VFD runs at depending on the number of ovens used. Error messages will appear on the screen to help with troubleshooting. The screen will flash and beep indicating a error has occurred, the alarm button can cancel this for 2 hours. If error has not been fixed beeping will return. The HMC has filter cleaning reminders available.

**LT1 & LT2** - These are light bulbs at each end of the hood, and should illuminate when the HUI light button is touched, touch it again and the light turns off.

**M1** – The Exhaust Fan Motor is a 3-phase, direct drive motor. In normal operation, it is powered by the VFD and its RPM will vary as the frequency from the VFD varies. There are no user serviceable parts in the motor, and the bearings are permanently lubricated.

**M2 & M3** – The Cooling Fan Motor is a 24 VDC, direct drive motor. In normal operation, it is powered through HMC. These fans are used to keep the control box for the hood cool. There are no user serviceable parts in the motor, and the bearings are permanently lubricated.

**PLUG 1, 2, & 3** – These are circular electrical plugs on one end of the SRC. The plugs connect to Receptacles 4, 5, & 6 on the back of the hood. The other end of the SRC plugs into the oven wire harness, and eliminates the operator switch supplied in the oven. Conversely, when the HUI on the hood is turned off, the corresponding oven is turned off as well.

**PS** –The Power Supply rectifies line voltage to 24 VDC, and supplies power to the HMC, cooling fans, and fire suppression

**R1** – Is a SPDT relay, which is an electrically operated switch. It uses an electromagnet to operate a switching mechanism. Voltage is supplied from TS1-9 to Ansul agent box. Once the fire alarm is activated voltage returns to TS1-10 over to HMC P8. That same voltage continues to R1-1 activating the coil in the relay, causing the contacts in the relay to switch from NC to NO. This will switch 24 VDC from terminal 6 to terminal 5 on the VFD causing the M1 to operate at 60 Hz.

**R2** – Is a SPDT time delay relay, which is an electrically operated switch. It uses an electromagnet to operate a switching mechanism. Voltage continues from R1-6 to R2 via the red wire activating the coil in the relay, causing the contacts in the relay to switch from NC to NO after one second has expired. This action delays the application of the voltage on terminal (5) on the VFD.

**REC 1, 2, & 3** - These are electrical receptacles, which supply line voltage for the ovens. Each receptacle should have a 20A dedicated breaker supplied from the buildings electrical panel. Line voltage to each receptacle is supplied via HMC P3. If fire alarm is activated P3 will disrupt line voltage being supplied to receptacle shutting the oven off.

**REC 4, 5, & 6** - These are circular electrical receptacles mounted on the back of the hood. The SRC connects into these. This deactivates the main oven switch located on the oven and relocates the operation of it to the HUI. This capacitive touch (NO) switch is located on the front of the hood and controls the lights.

**TS 1 & 2** - These are terminal strips, that serve as a connection point for wires.

**VFD** - The Variable Frequency Drive converts the AC supply voltage to DC and then converts the DC to a suitable three-phase frequency source for M1. Incoming power connects to terminals L1 & L2. M1 connects to terminals T1, T2, & T3 through TS1. The HMC sends the command to the ModBus to set the frequency for the combination of ovens selected. The VFD can receive a signal from the fire suppression system to command the drive to run at 60 Hz.

A complete manual can be found at [www.xltovens.com](http://www.xltovens.com).

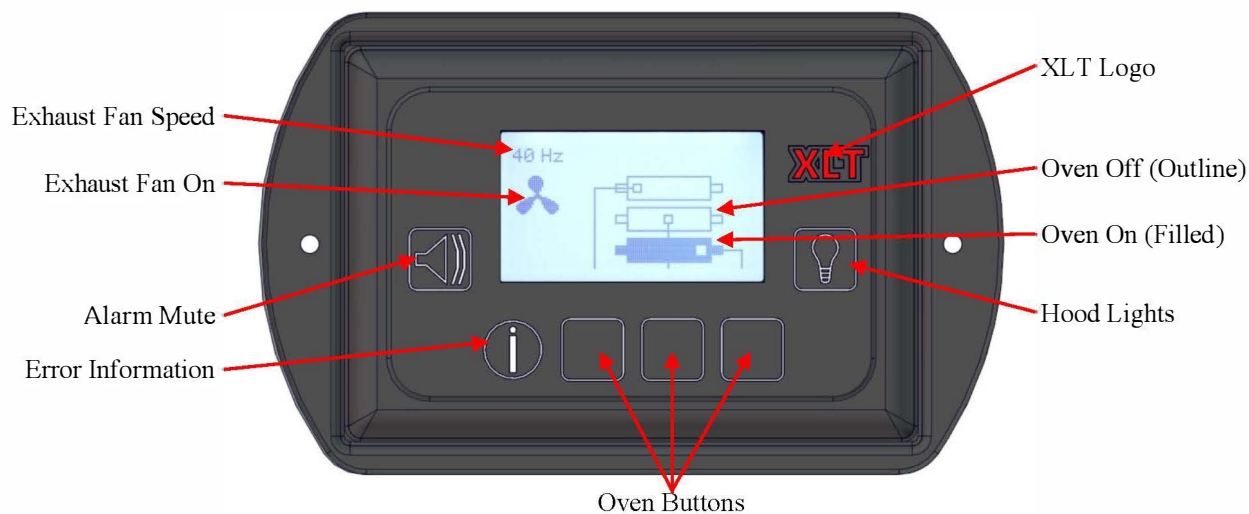

**Figure 1**

**Mechanical Function**

If your oven does not function properly, please verify the following conditions:

1. Verify that the power cord to the oven is connected and/or plugged in if equipped with a plug and receptacle.
2. Check all circuit breakers on the oven control panel to ensure they have not been tripped.
3. Check to see that the circuit breakers in the building electrical service panel have not been tripped or turned off.
4. Check the Manual gas valve to verify that it is turned on completely. The handle on the valve should be parallel with the gas piping when the valve is turned on, and the handle will be perpendicular with the gas piping when the valve is turned off. Also remember that anytime the gas hose has been disconnected it will take time to purge the air from the gas train.
5. Verify that oven is supplied with gas by disengaging and reengaging the quick-disconnect fitting on the gas hose.
6. Check to see that the oven is fully assembled. All of the fingers must be properly installed. Incorrect or incomplete finger placement can cause a “windy” condition that can cause the burner not to light.
7. Gas line size and pressure must be adequate to support total BTU requirements with all appliances in store turned **on**. Refer to the “Oven Gas Requirements” section of this manual.
8. (Australia Only) In the case of the oven not lighting properly. Turn off the oven and press and hold the manual reset switch on the back of the control box for five seconds. Wait approximately 30 seconds or until the fan stops spinning and turn the oven back on.
9. (World Installations) If using the Sail Switches check the HUI for error messages relating the Sail Switch sequencing.

If your oven still does not function properly, XLT has qualified customer service personnel that can provide assistance on any type of XLT oven problem you may experience. Customer Service is available 24/7/365 at 888-443-2751, or visit [www.xltovens.com](http://www.xltovens.com).



**HIGH  
VOLTAGE**

**Removing the hood VFD cover panel exposes high voltage. Proceed with caution and read the following the instructions carefully.**

#### **Initial troubleshooting of the hood:**

1. Remove panel covering VFD to check and see if the circuit breaker is tripped.
2. Check the actual frequency of the VFD controller. To access the actual frequency, press <ESC> button until the Display Mode shows D001.
3. Check to see that the breaker in the service panel is not tripped.
4. Make sure the Switch Relocation Cords (SRC) are properly installed to the oven(s).
5. Check to see that the grease filters are clean & installed properly.
6. Check to see if the exhaust fan is rotating in the correct rotation. To verify fan rotation, remove the lid on the exhaust fan. Visually inspect rotation in accordance with label on fan housing.

#### **Hood Machine Control LED Lights:**

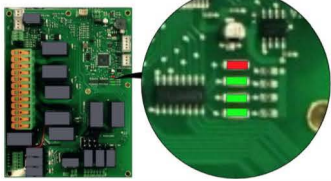

1. When the Red LED is lit it indicates an MC error.
2. When the first Green LED is lit it indicates power to MC.
3. When the second Green LED is lit it indicates that the exhaust fan on.
4. When the third Green LED is lit it indicates the MC communication to the VFD.

The VFD has internal diagnostics, and may show the following ERROR codes:

- F004 DC bus voltage fell below min value.
- F005 DC bus voltage fell below max value.
- F007 Motor Overload.
- F008 Heat sink Over Temp.
- F013 Ground Fault.
- F081 Comm Loss- RS485 port stopped communicating.

If any of the above error codes are displayed, then follow these steps to clear them.

1. Record error code on HUI.
2. Take the cover off the hood.
3. Cycle power with circuit breaker

If the corrective actions listed above do not correct the problem, then XLT has qualified customer service personnel that can provide assistance on any type of XLT Oven or AVI Hood problem you may experience. Customer Service is available at 888-443-2751 24/7/365, or visit [www.xltovens.com](http://www.xltovens.com).

For repairs or maintenance of the fire suppression system and components, contact the local Ansul dealer or XLT for assistance.

## Large User Interface Programming Procedure



**Read the entire instruction before programming.**

**TIP**

## Configuration Key Functions

ENTER = Used to select and save parameters.

HIDDEN = Behind the XLT is a hidden button. This is used along with the up and down button to access the programming mode.

UP = Increases the setting of the selected parameter.

DOWN = Decrease the setting of the selected parameter.

To enter factory tech mode press both UP and DOWN button simultaneously for 10 seconds and the following parameters will be displayed:

1. Software Version
2. Serial Number Entry
3. Elapsed Time:
  - Total Hours.
  - Hours Since Filter has been Cleaned.
4. Belt Length: 32 = 1832 40 = 2440 or 3240 55 = 3255 or 3855 70 = 3270 or 3870
5. Belt Width: 18 = 1832 24 = 2440 32 = 3240, 3255, or 3270 38 = 3855 or 3870
6. Main Fan Type:
  - Defaults to On/Off.
7. Split Belt:
  - Defaults to No.
8. Dual Burner:
  - Available on oven sizes 3270 and 3870.
9. Fuel Type:
  - Gas Oven or Electric Oven.
10. Remote Hood Switch Installed:
  - Defaults to No.
11. Temperature Offset Adjustments:
  - Offset shown in degrees F.
12. High Temperature range from 590°F (310°C) to Low Temperature.
13. Low Temperature range from 350°F (177°C) to High Temperature.
14. Main Fan (Amps):
  - Press <Enter> to see isolated Amp load.
15. Belt Direction:
  - Defaults to right to left.
  - Can be switched to left to right without physically changing the wire belt direction.
16. Main Fan Off Delay:
  - Defaults to auto 225°F (107°C)
17. Beeper Button Test

## VFD (World) Programming Procedure



**Read the entire instruction before programming.**

**TIP**

Configuration Key Functions

ENTER = Used to select and save parameters.

ESCAPE = Used to return to previous menu.

UP = Increases the setting of the selected parameter.

DOWN = Decrease the setting of the selected parameter.



With the Oven Control switched off and power connected to the oven, the VFD should show 0.0 on the display.

### Programming Instructions For Factory Parameters

1. Press ESCAPE to show (d001) with (1) flashing.
2. Press ESCAPE again, now (d) is flashing.
3. Press DOWN Arrow until (P) is flashing and press ENTER.
4. (P101) is displayed with (1) flashing.
5. Press UP Arrow until (P106) is displayed and press ENTER.
6. Press UP Arrow until (2) is displayed and press ENTER.
7. Press ESCAPE and (P106) should be shown with (6) flashing.
8. Press UP Arrow until (P108) is displayed and press ENTER.
9. Press UP Arrow until (1) is displayed and press ENTER.
10. Press ESCAPE to show (P108) displayed.
11. Press ESCAPE again to have (P) flash, and press UP Arrow until (A) is displayed.
12. Press ENTER to have (1) flash.
13. Press UP Arrow until (A451) is displayed and press ENTER.
14. Press UP Arrow until (9) is shown and press ENTER.
15. Press ESCAPE then press UP Arrow until (A458) is displayed and press ENTER.
16. Press UP Arrow until (1) is displayed and press ENTER.
17. Press ESCAPE two times and the display should read (A458) with (A) flashing.
18. Press the DOWN Arrow until (d001) is displayed and press ENTER.
19. Press ENTER two more times for the display to show (0.0).

**TIP**

**Read the entire instruction before programming.**

### **Programming Instructions For Lower Than 60 Hz**

1. Press ESCAPE to show (d001) with (1) flashing.
2. Press ESCAPE again, now (d) is flashing.
3. Press DOWN Arrow until (A) is flashing and press ENTER.
4. Press UP Arrow until (A458) is displayed and press ENTER.
5. Press UP Arrow until (0) is displayed and press ENTER.
6. Press ESCAPE and (A458) is shown with (8) flashing.
7. Press DOWN Arrow until (A409) is displayed and press ENTER.
8. Press DOWN Arrow until desired Hz is displayed and press ENTER.
9. Press ESCAPE until (A409) is displayed.
10. Press DOWN Arrow until (d001) is displayed and press ENTER.
11. Press ENTER two more times for the display to show (0.0).

### **Programming Instructions For Up To 65 Hz Max**

1. Press ESCAPE to show (d001) with (1) flashing.
2. Press ESCAPE again, now (d) is flashing.
3. Press DOWN Arrow until (P) is flashing and press ENTER.
4. Press UP Arrow until (P105) is displayed and press ENTER.
5. Press UP Arrow until desired Hz is displayed and press ENTER.
6. Press ESCAPE until (P) is flashing on display showing (P105).
7. Press UP Arrow until (A) is flashing and press ENTER.
8. Press UP Arrow until (A409) is displayed and press ENTER.
9. Press UP Arrow until desired Hz is displayed and press ENTER.
10. Press ESCAPE once and UP Arrow until (A458) is displayed and press ENTER.
11. Press the UP Arrow until (1) is displayed and press ENTER.
12. Press ESCAPE until (A458) is displayed.
13. Press DOWN Arrow until (d001) is displayed and press ENTER.
14. Press ENTER two more times for the display to show (0.0).

## Conveyor Speed Settings



**Read the entire instruction before programming.**

**TIP**

## Configuration Key Functions

ENTER = Used to select and save parameters.

HIDDEN = Behind the XLT is a hidden button. This is used along with the up and down button to access the programming mode.

UP = Increases the setting of the selected parameter.

DOWN = Decrease the setting of the selected parameter.

1. To enter conveyor settings press and hold 3 buttons (HIDDEN, UP, and DOWN) for 10 seconds to enter.
2. Displays will show programming screens before auto-exiting after 5 seconds of no activity.

Min Time

90

**Min Time**

Factory default is 90. To change, press ENTER. Use Up/Down arrows to change time which is shown in seconds. Press ENTER to accept and advance.

Max Time

1200

**Max Time**

Factory default is 1200. To change, press ENTER. For 1832 use 1020 and all other models will be 1200. Use Up/Down arrows to change time which is shown in seconds. Press ENTER to accept and advance.

Sprocket Diameter

1.77

**Sprocket Diameter**

Factory default is 1.77. To change, press ENTER. Use Up/Down arrows to change diameter. Press ENTER to accept and advance.

Final Gear Ratio

300

**Final Gear Ratio**

Factory default is 300. To change, press ENTER. Use Up/Down arrows to change gear ratio. Press ENTER to accept and advance.

Trim Speed %

100

**Trim Speed**

Factory default is 100. To change, press ENTER. Use Up/Down arrows to change trim speed. Press ENTER to accept and advance.

**Directional Change of the Conveyor Belt**

The conveyor belt is non-directional. This means there is NO physical change of the belt when wanting to change direction; it is now as easy as a programming change. To change the direction:

1. Enter Factory Tech Mode by pressing and holding the 2 arrow buttons for 10 seconds.
2. Press Down arrow to cycle through screens.
3. On Belt Direction, press ENTER and use Up/Down arrows to change.
4. Press ENTER to accept and advance.

**On-Off Valve Adjustment Procedure**

Check Incoming Pressure:

- Loosen screw 1 full turn counter clockwise (Figure 1)
- Connect Manometer to this test port
- Turn the LUI to on position and wait for burner to light (up to 30 seconds)
- Document incoming pressure on startup checklist. (If new installation)

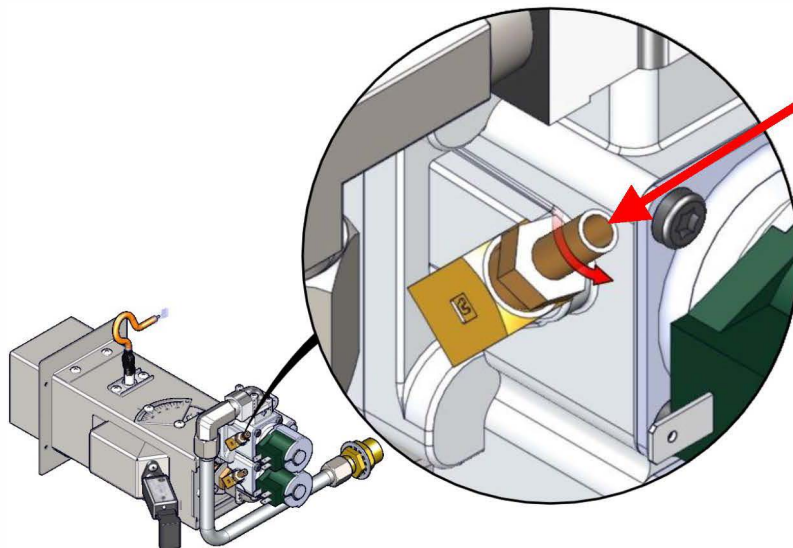

Figure 1

- Turn the LUI to the off position
- Disconnect Manometer
- Tighten screw clockwise until snug (Figure 2)

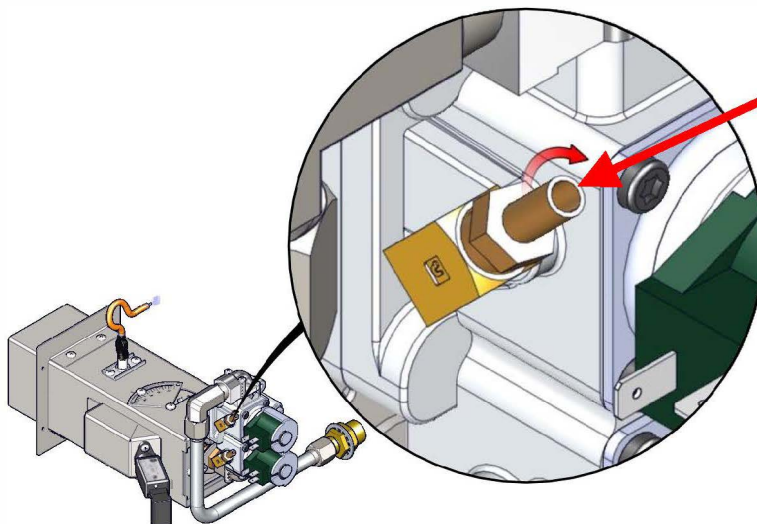

Figure 2

## On-Off Valve Adjustment Procedure

Check High Bias Pressure:

- Loosen adjustment screw 1 full turn counter-clockwise (Figure 3)
- Connect Manometer to this test port
- Turn the LUI to on position and wait for burner to light (up to 30 seconds)

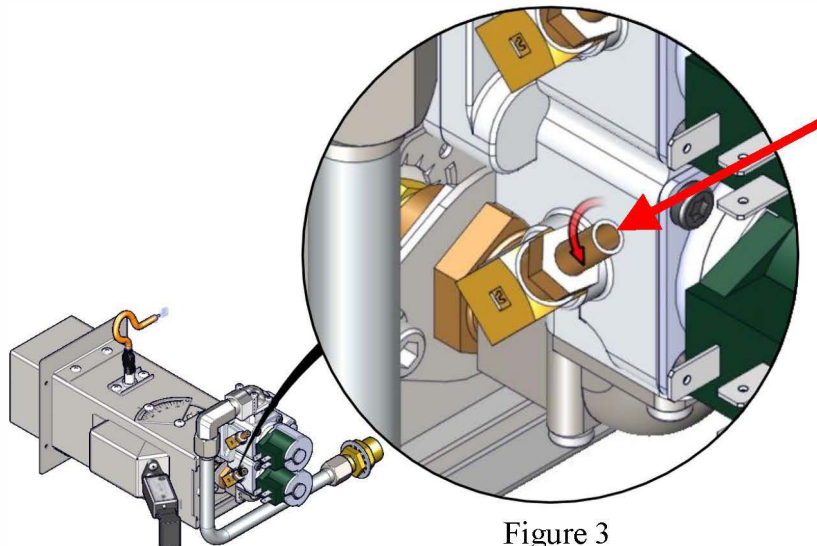

Figure 3

- Remove Seal Screw
- Turn the High Flame Bias Screw located behind the Seal Screw (Figure 4) until desired setting is achieved. Use chart below (Figure 5) for correct valve settings.
- Reinstall Seal Screw

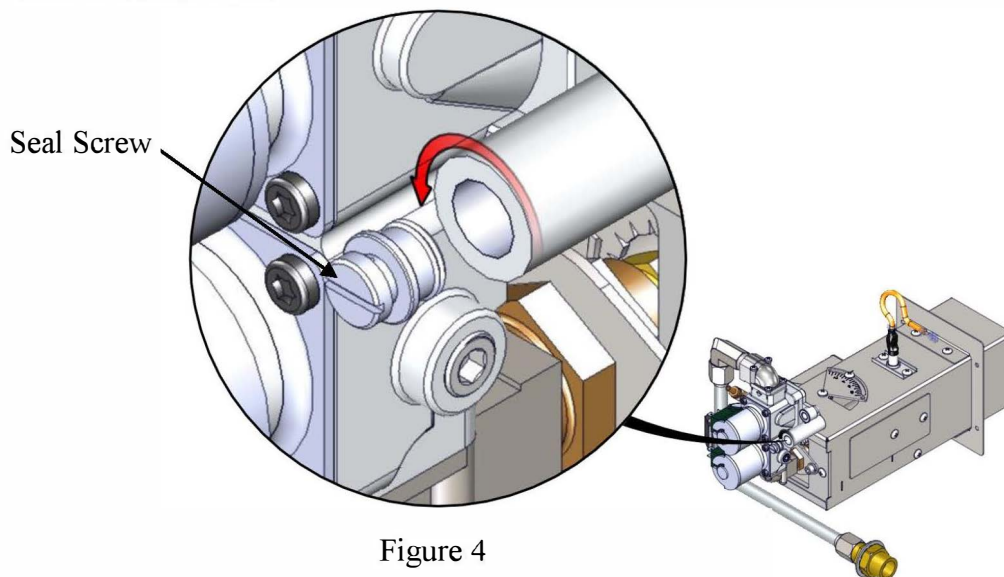
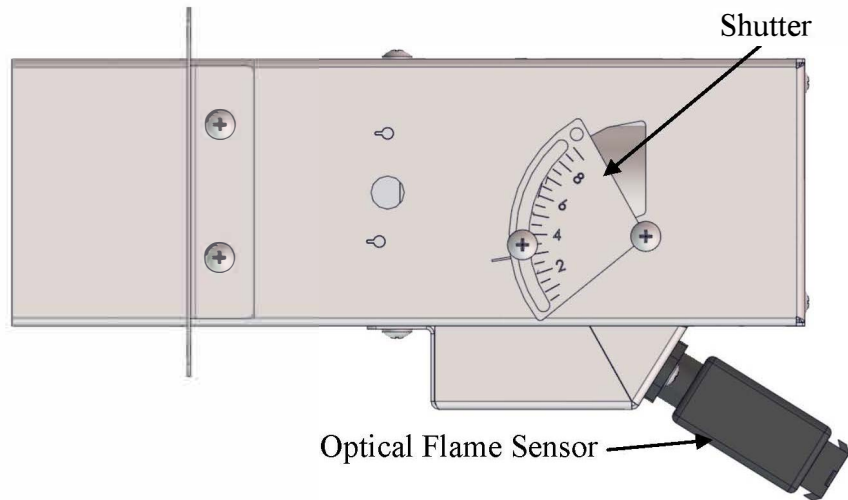

Figure 4

On-Off Valve Adjustment Settings						
All Oven Models	Natural Gas			LP Gas		
	W/C	mbar	kPa	W/C	mbar	kPa
High Flame Bias	3.5	8.75	0.875	10	25	2.5

Figure 5

## Air Shutter Settings - Original



Recommended Burner Shutter Settings			
All Oven Models		Natural Gas	LP Gas
Shutter	Standard	3.0	3.0
	HP	9.0	9.0



**NOTE**

New Installation– The shutter has been set at the factory. This should not need adjusted. If found loose call technical support for settings.

High Altitude– 6,000 ft and above the shutter may need adjusted. This should only be adjusted to keep flame lit and combustion to a minimum.

## Air Shutter Settings - Australia

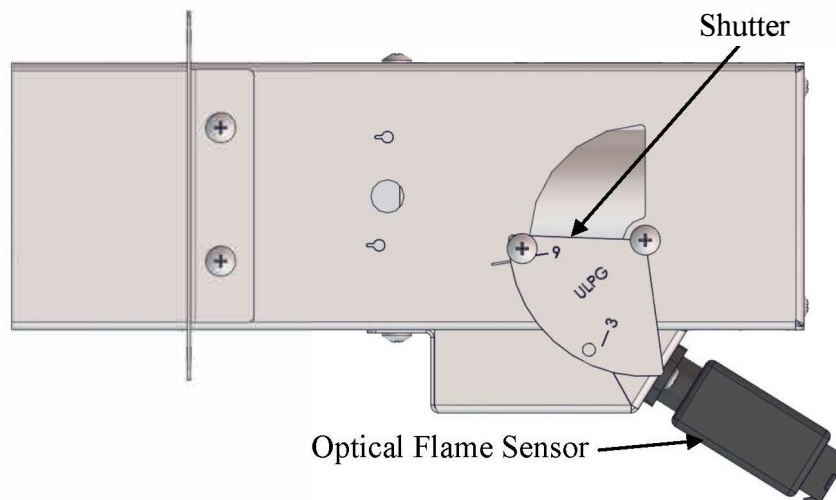

Recommended Burner Shutter Settings		
All Oven Models		ULPG Australia
Shutter	Standard	3.0
	HP	9.0



**NOTE**

Australia- ULPG settings are not to be adjusted per Australian Gas Association.

## Allen Bradley Power Flex 4M Restoring AVI Defaults



### TIP

**Read the entire instruction before programming.**

To reset VFD settings change P112 to 1 . The VFD will reset to factory default settings. To cycle power, turn circuit breaker off and on and the HMC will load the factory parameters into the VFD.

P105=65	Maximum Frequency
P106=2	Start Source
P108=4	Speed Reference
P110=2	Decel Time
A451=9	Auto Reset Tries
A452=60	Auto Reset Delay
T201=2	Terminal Block Group (I/O) Terminal 5
T202=6	Terminal Block Group (I/O) Terminal 6
A404=60	Jog Frequency

Test run the motor by turning on one of the oven/hood buttons located on the HUI.



Complete VFD manual available at [www.xltovens.com](http://www.xltovens.com).

VFD Controller Settings						
	Switches On			1832 & 2440	3240, 3255 & 3270	3855 & 3870
	Top	Middle	Bottom			
Single	X			20 Hz	25 Hz	30 Hz
Double	X			20 Hz	25 Hz	30 Hz
			X	35 Hz	40 Hz	45 Hz
	X		X	35 Hz	40 Hz	45 Hz
Triple	X			20 Hz	25 Hz	30 Hz
		X		30 Hz	35 Hz	40 Hz
			X	40 Hz	45 Hz	50 Hz
	X	X		30 Hz	35 Hz	40 Hz
	X		X	40 Hz	45 Hz	50 Hz
		X	X	40 Hz	45 Hz	50 Hz
	X	X	X	45 Hz	50 Hz	55 Hz
Fire Suppression				60 Hz-DO NOT CHANGE		

## **How to order Parts**

---

Have all information ready when calling XLT. Below is a list of information that is required for all orders. At the bottom of the Bill of Materials (BOM) on the following parts overview pages are additional requirements needed depending on your parts order.

### **Oven/Hood information required:**

- Model #
- Serial #
- Manufacture Date
- Phone #
- Contact name
- Bill to
- Ship to
- Credit card information

### **P.O.R = Price On Request**

**All prices are subject to change, contact XLT for current prices.**

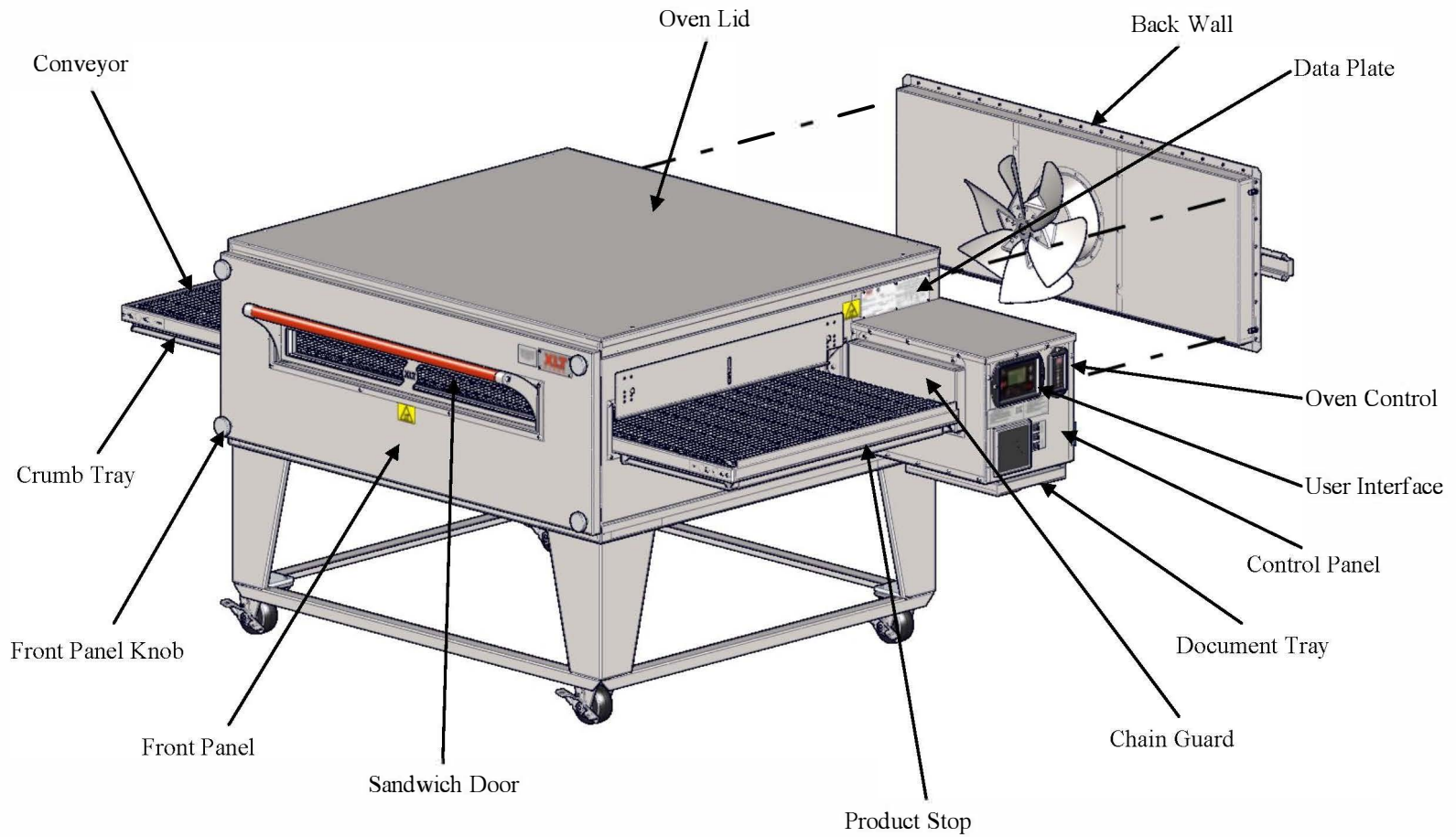

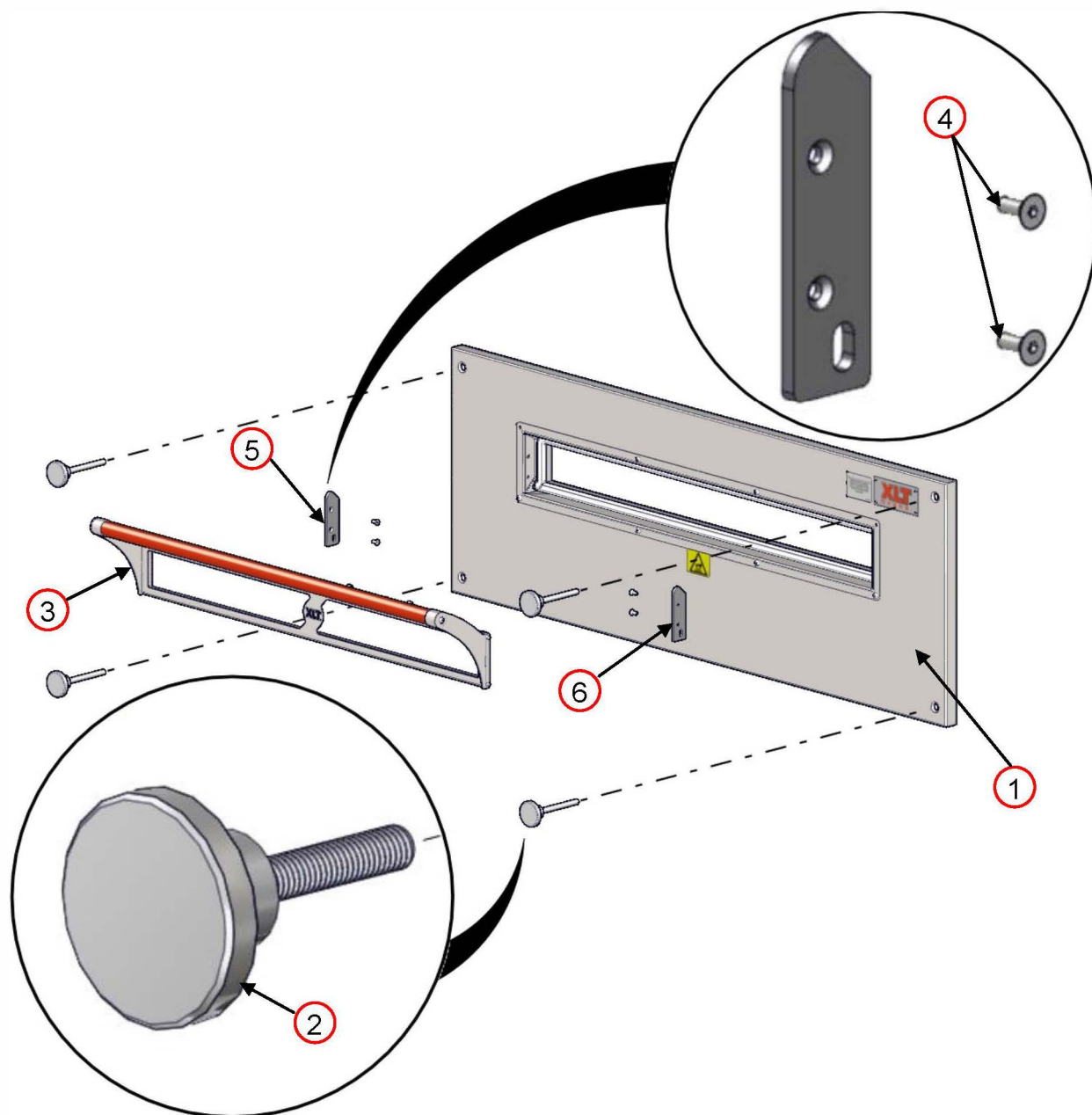

FRONT PANEL			
ITEM	PART NUMBER	DESCRIPTION	YOUR PRICE
1	XA 6500	Front Panel Assembly	P.O.R
2	XA 6505	Front Panel Knob	\$15.90
3	XA 6600	Sandwich Door	P.O.R
4	XF 126-2	Screw 10-24	P.O.R
5	XM 6703	Door Retainer Left	\$13.80
6	XM 6704	Door Retainer Right	\$13.80

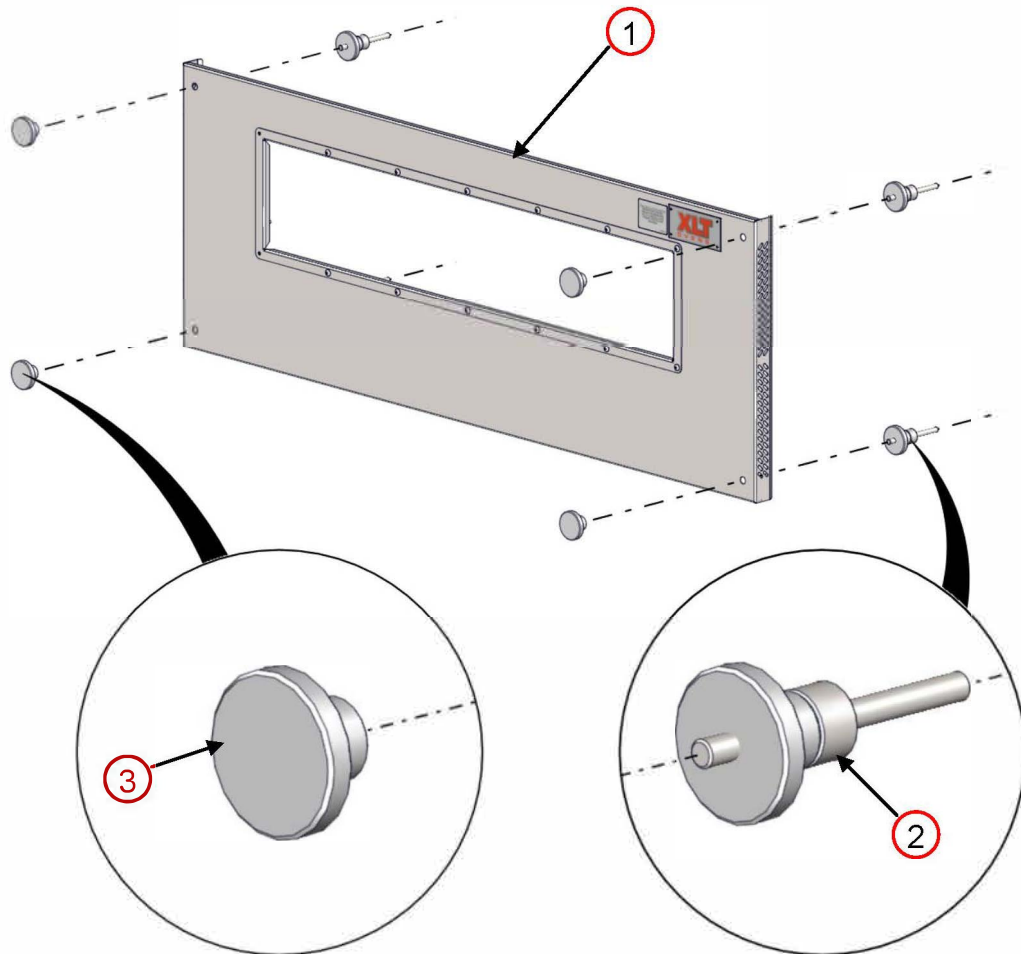

EXTENDED FRONT PANEL			
ITEM	PART NUMBER	DESCRIPTION	YOUR PRICE
1	XA 6700	Extended Front Panel	P.O.R
2	XA 6504	Front Panel Knob Assy Ext Frt	\$33.09
3	XP 6505	Front Panel Knob	\$14.49

**Front Panel information required:**

- Size of Oven
- Short or Long Window
- Stainless or Wood Handle
- 3” or 5” Window Opening

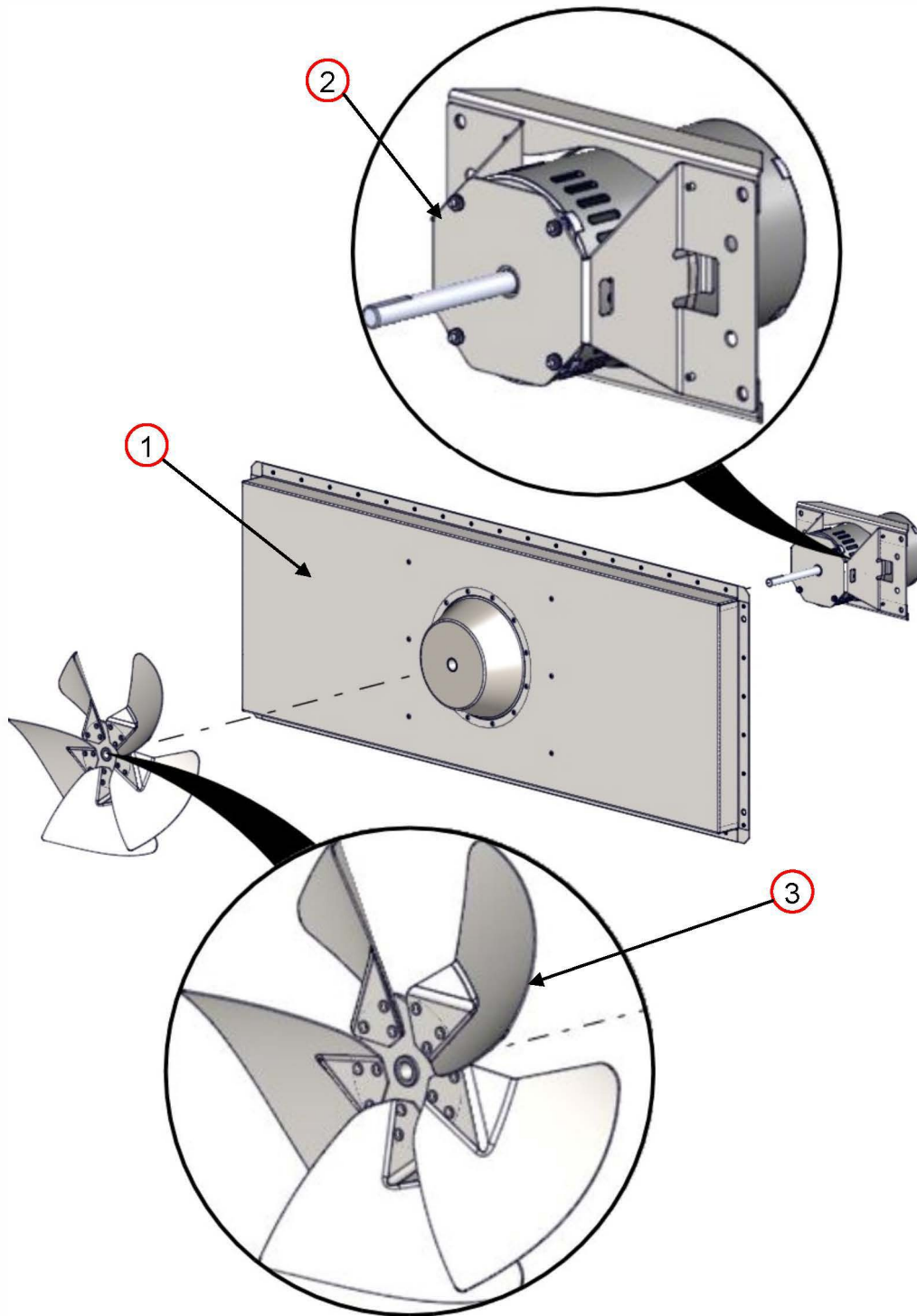

BACK WALL			
ITEM	PART NUMBER	DESCRIPTION	YOUR PRICE
1	XA 5001	Back Wall Assembly	P.O.R
2	SP 5009A-75	Fan Motor w/ Mount 3/4 HP	\$283.20
3	XA 5200	Fan Blade	P.O.R

**Back Wall information required:**

- Size of Oven
- Voltage

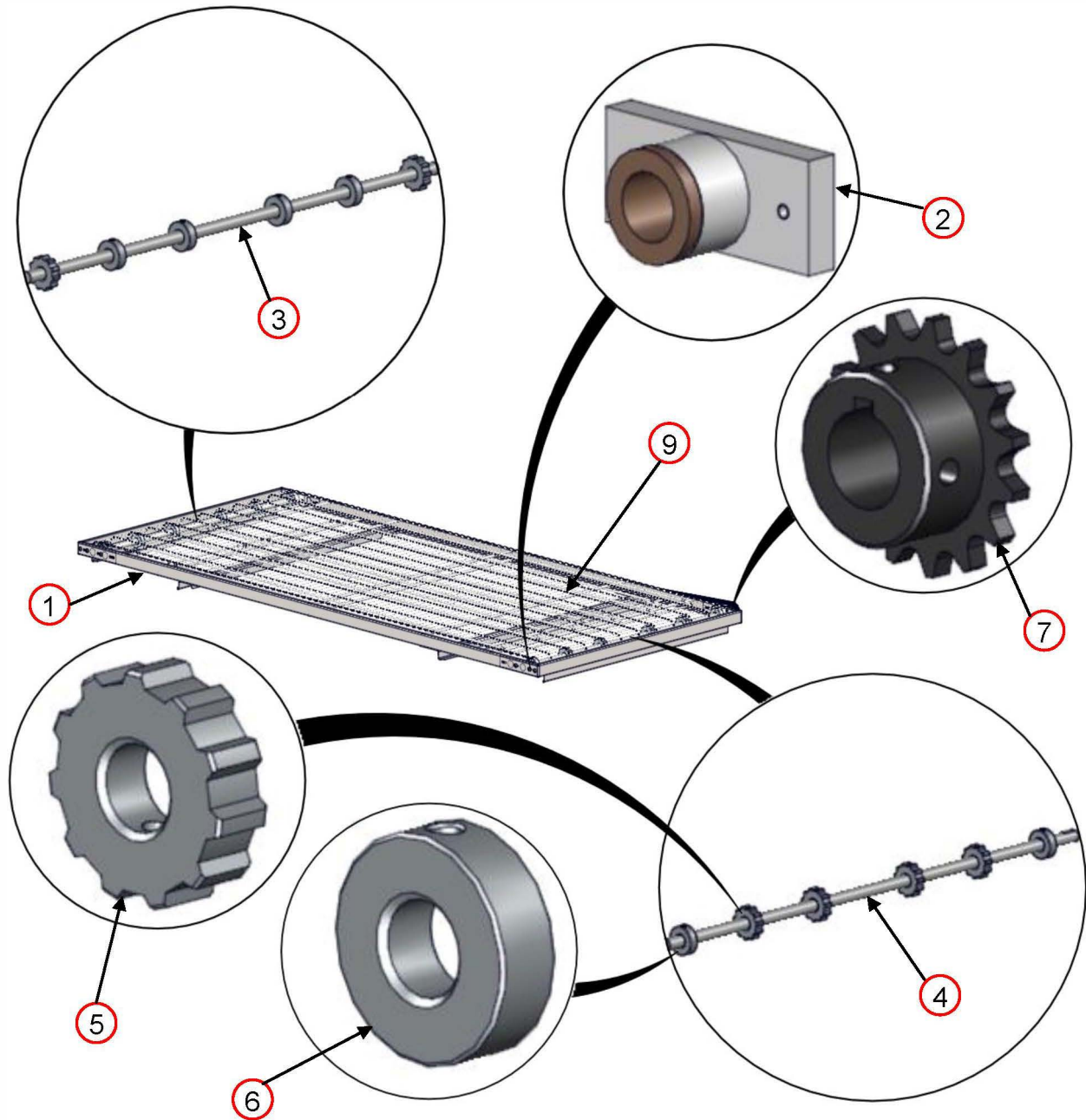

Conveyor Drive Chain not shown

CONVEYOR			
ITEM	PART NUMBER	DESCRIPTION	YOUR PRICE
1	XA 7000	Conveyor Assembly	P.O.R
2	XA 7200	Conveyor Bearing Assembly	\$9.30
3	XM 7301	Conveyor Shaft Idle	P.O.R
4	XM 7302	Conveyor Shaft Drive	P.O.R
5	XP 7403	Conveyor Roll Notched	\$12.20
6	XP 7404	Conveyor Roll Plain	\$11.00
7	XP 9503	Conveyor Sprocket Driven 15	\$15.50
8	XP 9504	Conveyor Drive Chain	\$23.60
9	XP 9506	Conveyor Belt	P.O.R

**Conveyor information required:**

- Oven Size
- Split Belt or Standard Belt

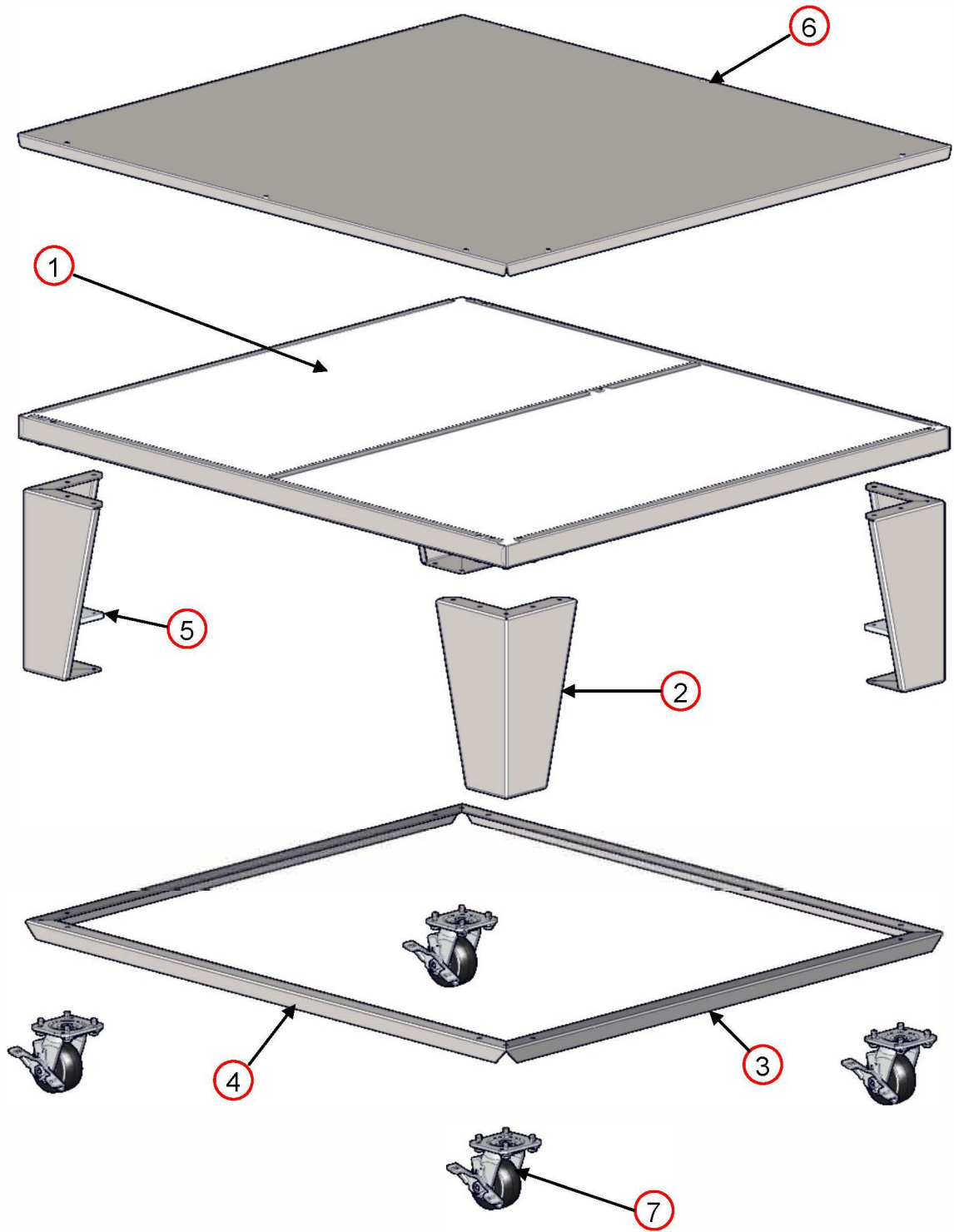

BASE			
ITEM	PART NUMBER	DESCRIPTION	YOUR PRICE
1	XA 1001	Base Assembly	P.O.R
2	XM 1003-15	Base Leg	\$65.40
3	XM 1006	Side Leg Angle	P.O.R
4	XM 1007	Front/Back Leg Angle	P.O.R
5	XM 1008	Bolster Plate	\$11.50
6	XM 1010	Oven Lid	P.O.R
7	XP 1004	Caster	\$21.60

**Base information required:**

- Size of Oven
- Single, Double, or Triple Stack

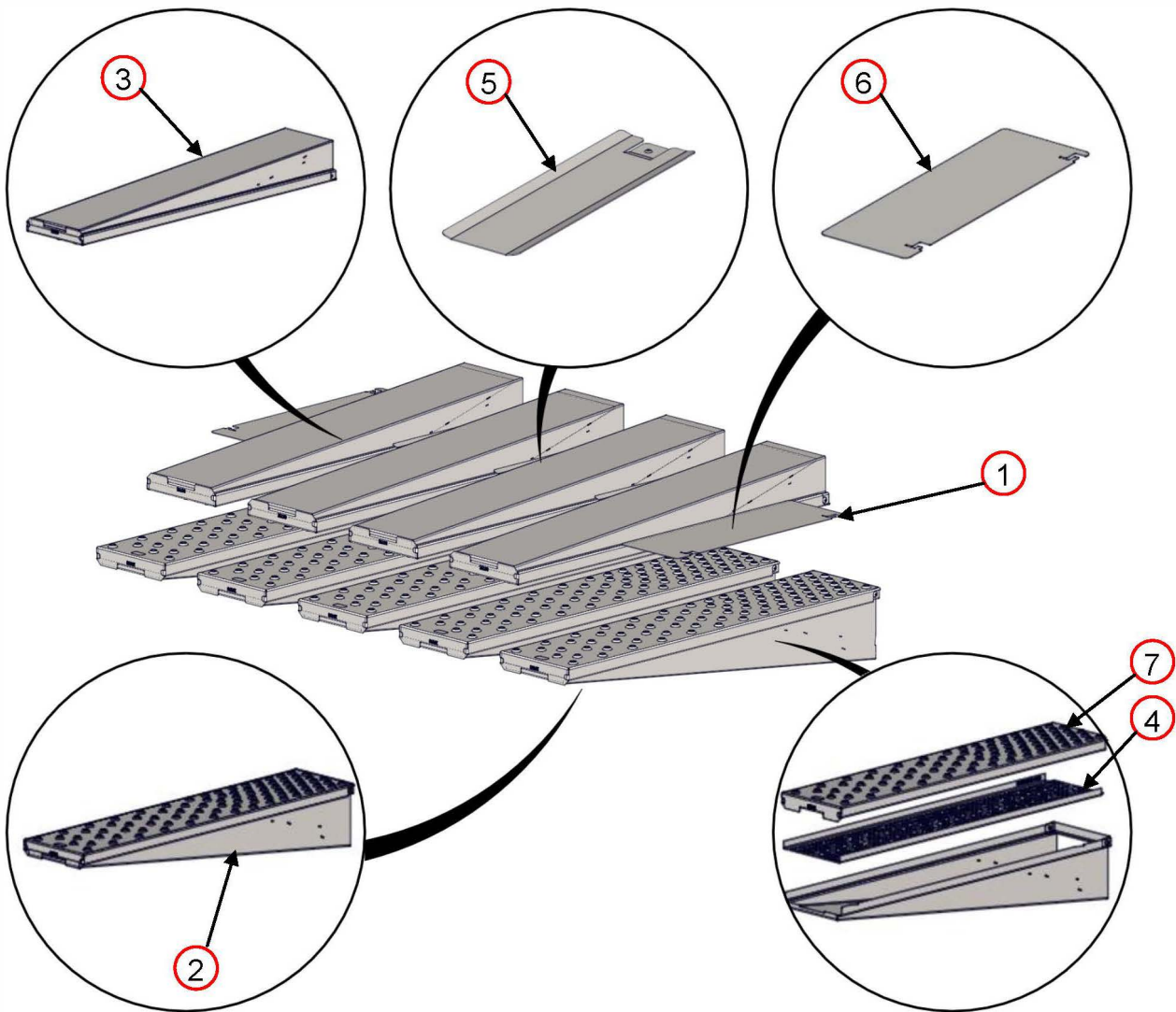

FINGERS			
ITEM	PART NUMBER	DESCRIPTION	YOUR PRICE
1	XA 8Xxxxx	Finger Group Assembly	P.O.R
2	XA 8001-B	Finger Body Bottom	P.O.R
3	XA 8001-T	Finger Body Top	P.O.R
4	XM 8004	Finger Inner Plate Perforated	P.O.R
5	XM 8024	EndLoss Plate	P.O.R
6	XM 8025	EndLoss Plate	P.O.R
7	XM 8xxx	Finger Outer Plate	P.O.R

**Finger information required:**

- Size of Oven
- Customer name
- Part number on front of finger outer

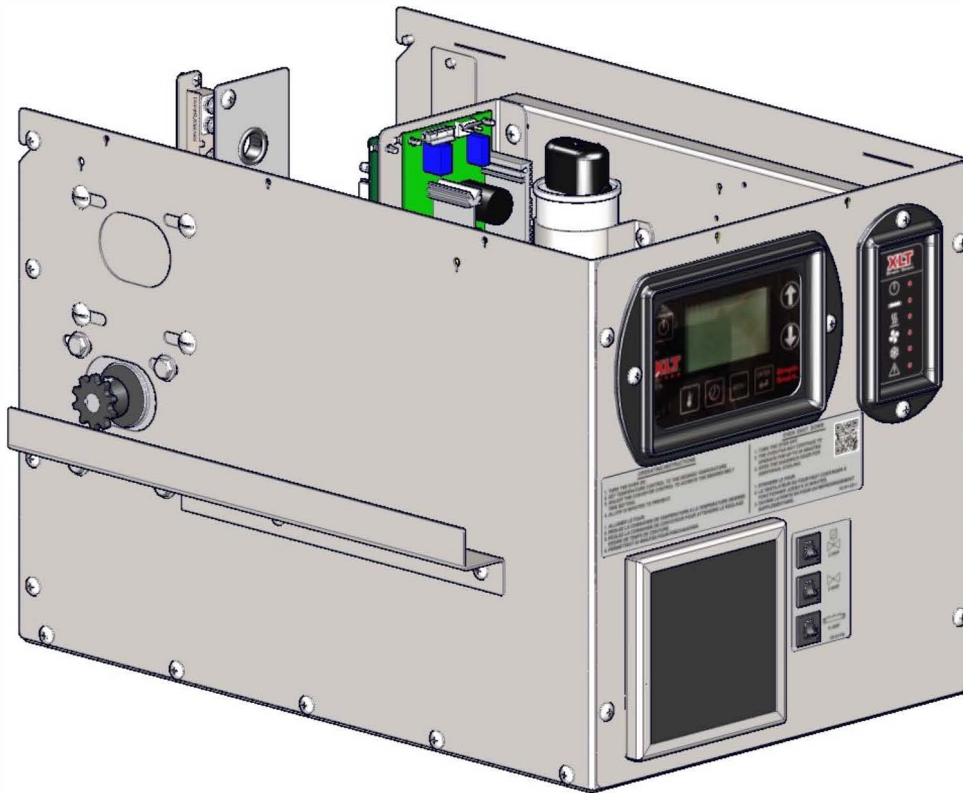

**Operating Position (shown with lid removed)**

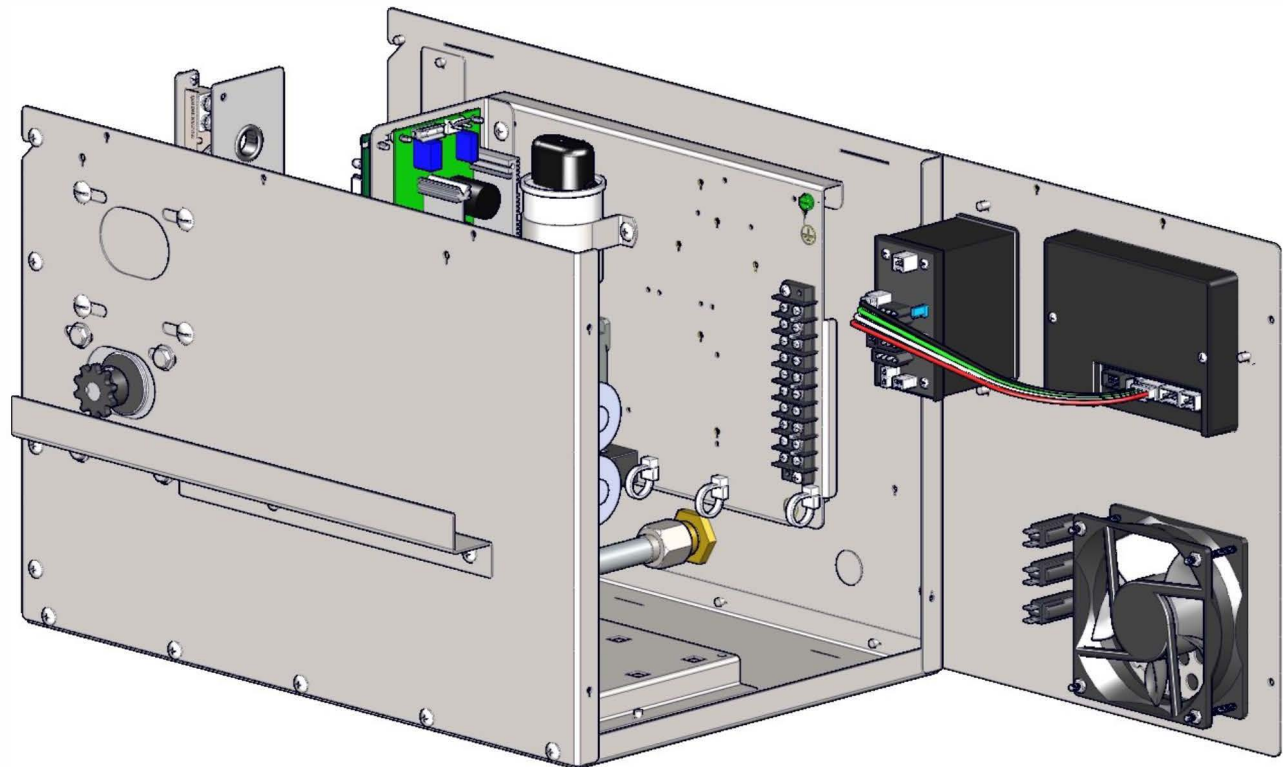

**Service Position**



CONTROL PANEL			
ITEM	PART NUMBER	DESCRIPTION	YOUR PRICE
1	SP 4520-GA	Fan Guard / Filter Holder	\$5.60
2	XP 4170-LUI	Large User Interface	P.O.R
3	XP 4175-MC	Oven Control	P.O.R
4	XP 4501-GA	FPPG Fan Standard M2	\$25.00
5	XP 4515-CB	Circuit Breaker	\$6.95
6	XP 4520-GA	Fan Filter	\$1.95

**Control Panel information required:**

- Size of Oven
- Voltage
- Circuit Breaker amp rating
- Conveyor Belt direction

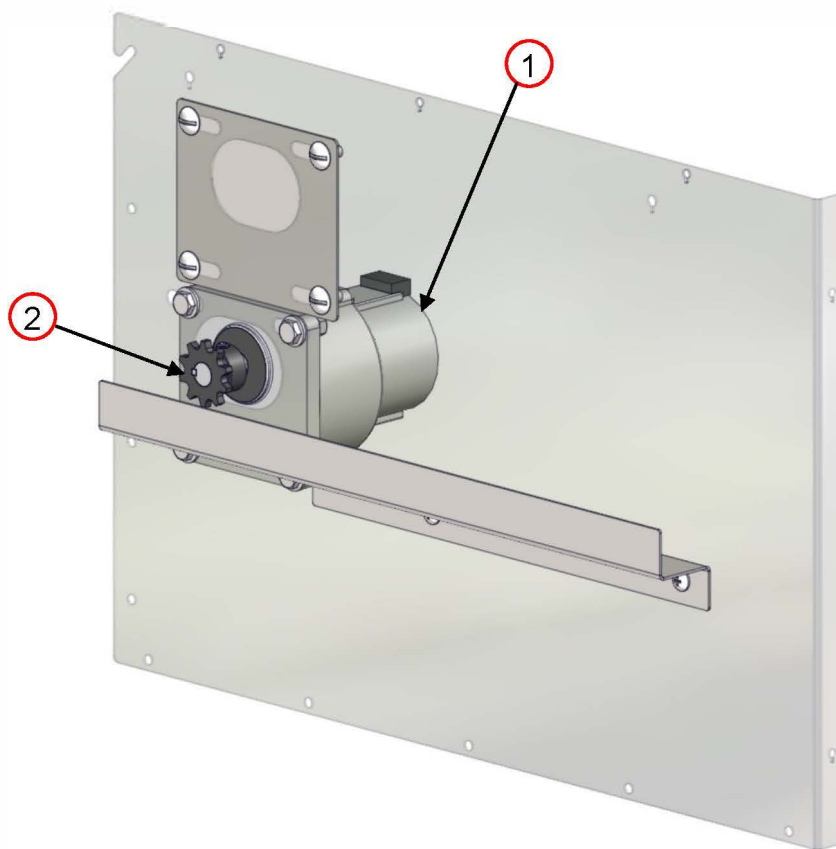

CONTROL BOX FRONT			
ITEM	PART NUMBER	DESCRIPTION	YOUR PRICE
1	XA 4117-12.5 RPM STD	Conv Motor Assy 12.5 RPM STD	\$305.30
2	XP 4155	Sprocket Conveyor Drive 10T	\$15.70

**Control Box Front information required:**

- Size of Oven
- Split Belt or Standard Belt

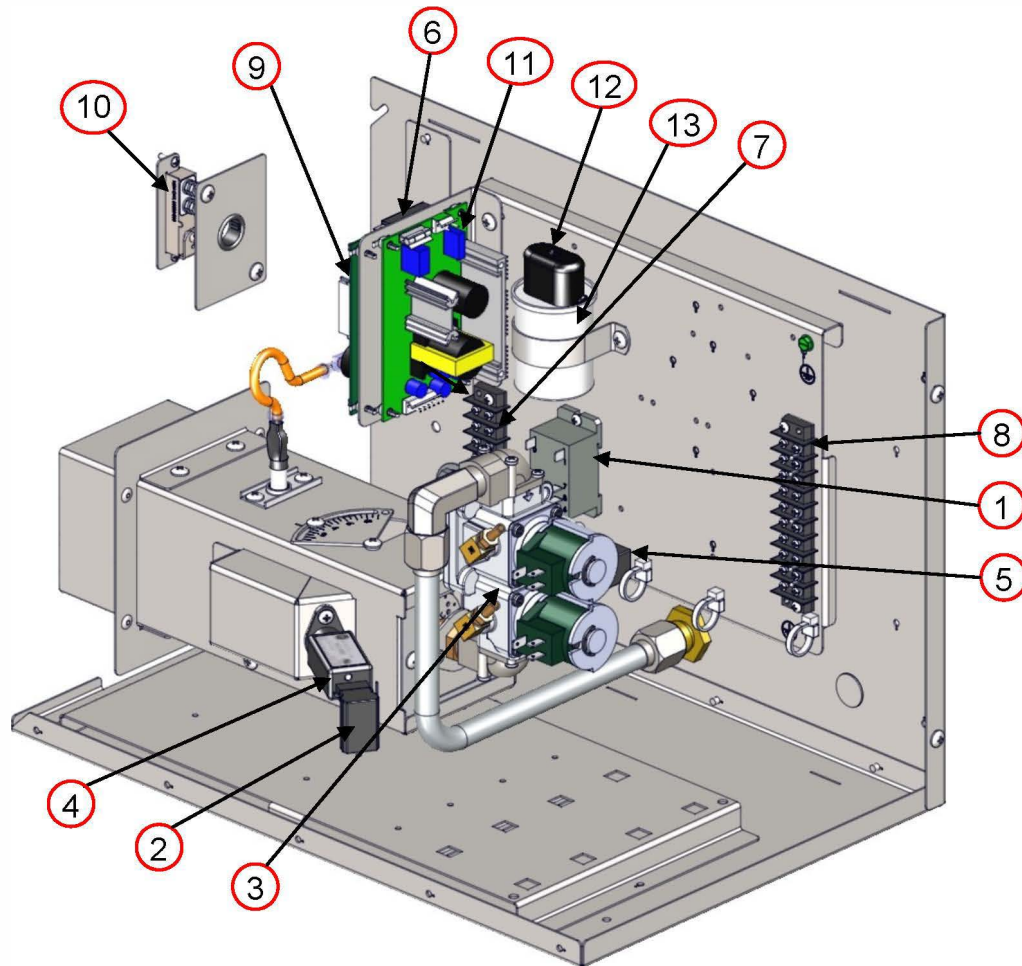

CONTROL BOX BACK			
ITEM	PART NUMBER	DESCRIPTION	YOUR PRICE
1	HP 2067A-24VDC	Relay 8 Pin 30A 24VDC	P.O.R
2	XH 4211-DC	UV Flame Detector Wire Plug	\$11.46
3	XP 4207A-DI-N/P	On Off Valve	P.O.R
4	XP 4210-UV-DC	Flame Detector 24VDC	\$109.00
5	XP 4310A	Current Sensor	P.O.R
6	XP 4515-CB-15A	15 Amp Circuit Breaker	P.O.R
7	XP 4701A-04	Terminal Strip 4 Place	P.O.R
8	XP 4701A-10	Terminal Strip 10 Place	P.O.R
9	XP 4705A-DI-24	Ignition Control 24VDC	\$77.00
10	XP 4713A	High Temp Limit Switch	P.O.R
11	XP 4716	Power Supply PS	\$32.40
12	XP 5012	Capacitor Boot	\$2.30
13	XP 5014-30	Capacitor Baldor 3/4 HP 30uF	\$18.60

**Control Box Back information required:**

- Size of Oven
- Voltage

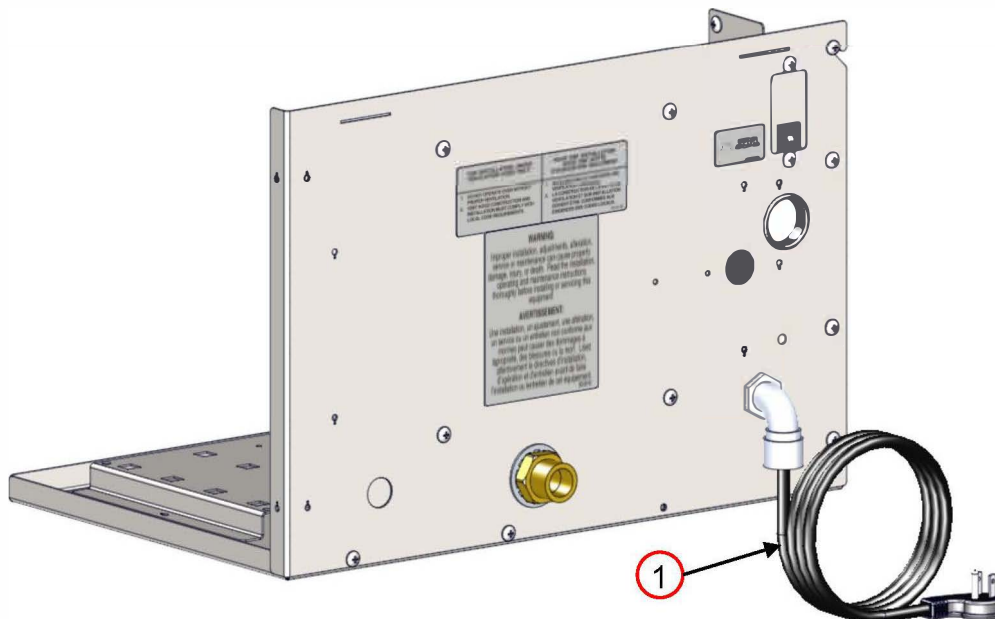

CONTROL BOX REAR			
ITEM	PART NUMBER	DESCRIPTION	YOUR PRICE
1	XA 9301-S	Power Cord Assembly	\$28.40

**Control Box Rear information required:**

- Size of Oven
- Voltage

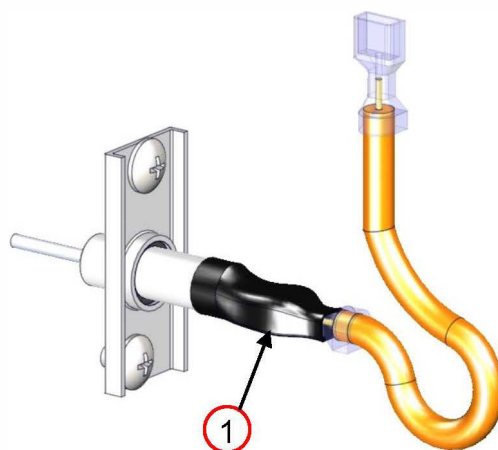

BURNER			
ITEM	PART NUMBER	DESCRIPTION	YOUR PRICE
1	XA 4203-DI-SQ	FS/SI Assembly	\$52.90

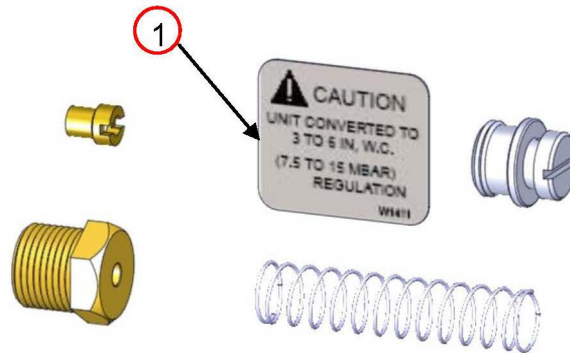

NATURAL GAS VALVE			
ITEM	PART NUMBER	DESCRIPTION	YOUR PRICE
1	SP 9910A-QF-NAT	Natural Gas Conversion Kit	P.O.R

**Burner information required:**

- Size of Oven

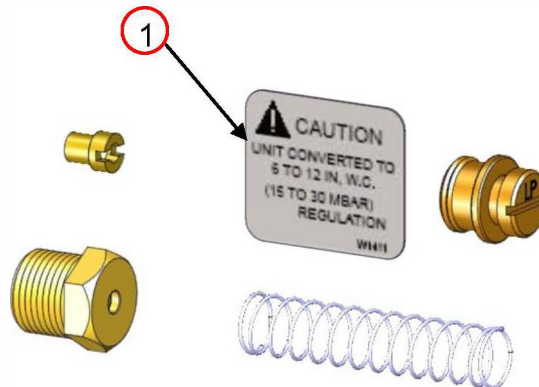

PROPANE VALVE			
ITEM	PART NUMBER	DESCRIPTION	YOUR PRICE
1	SP 9910A-QF-LPG	Propane Conversion Kit	P.O.R

**Burner information required:**

- Size of Oven

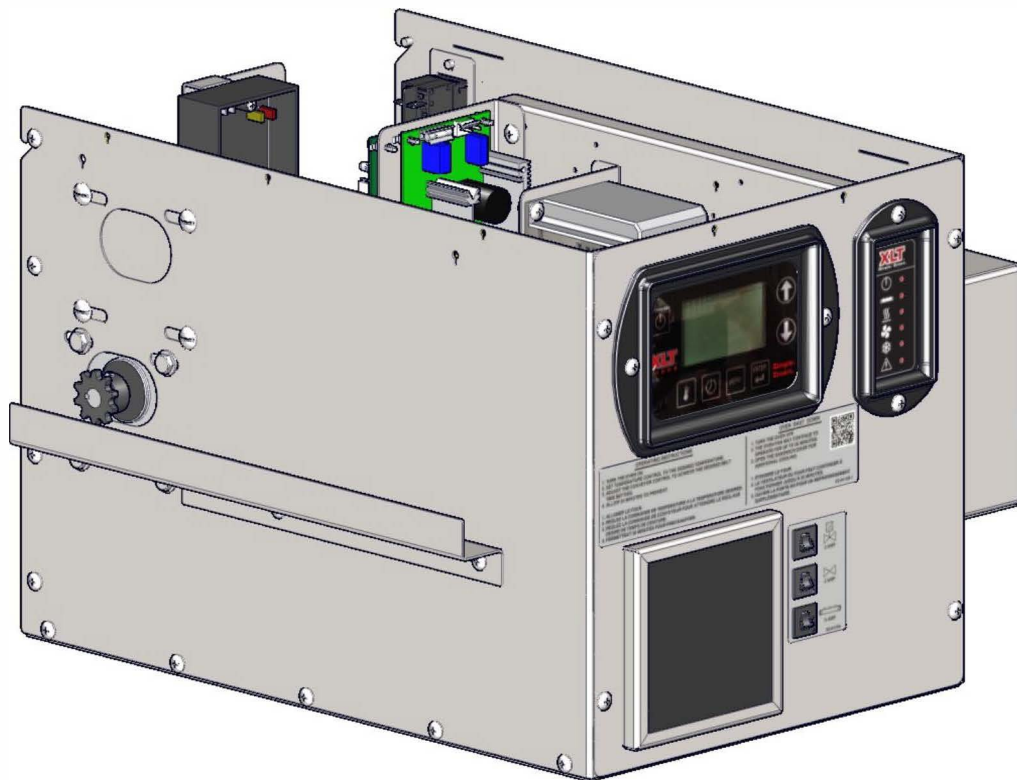

**Operating Position (shown with lid removed)**

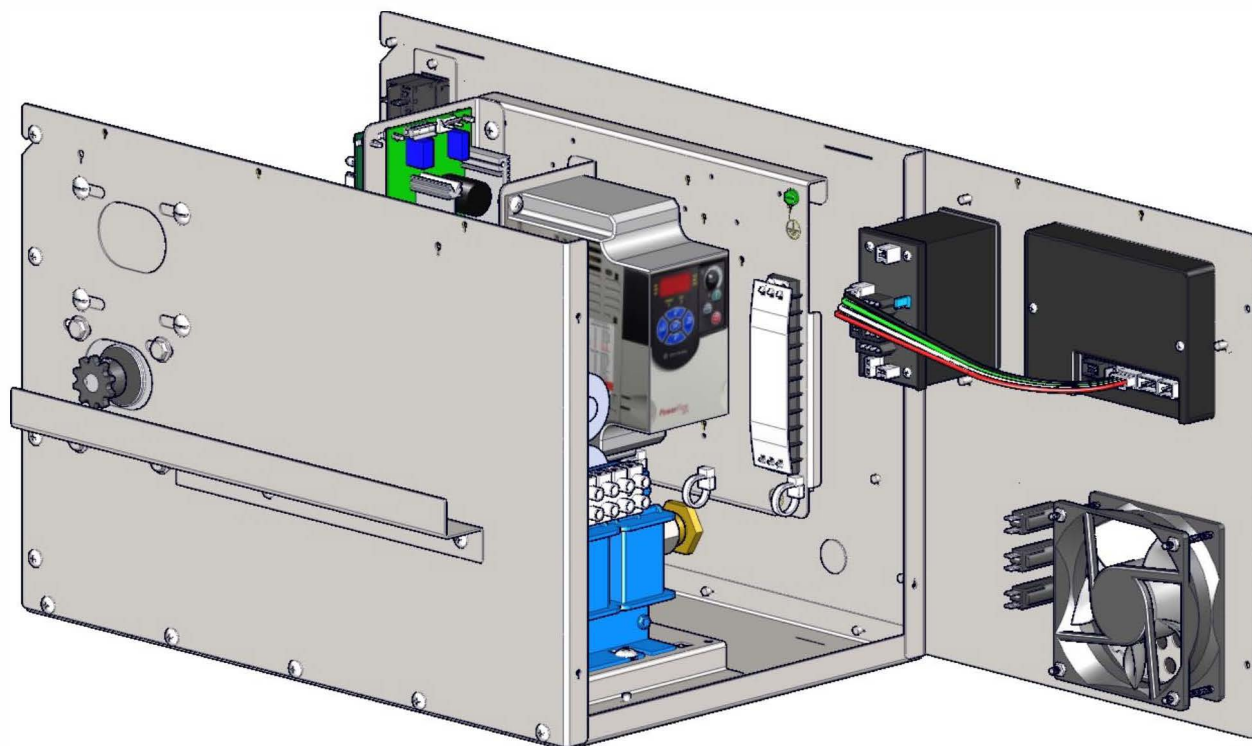

**Service Position**

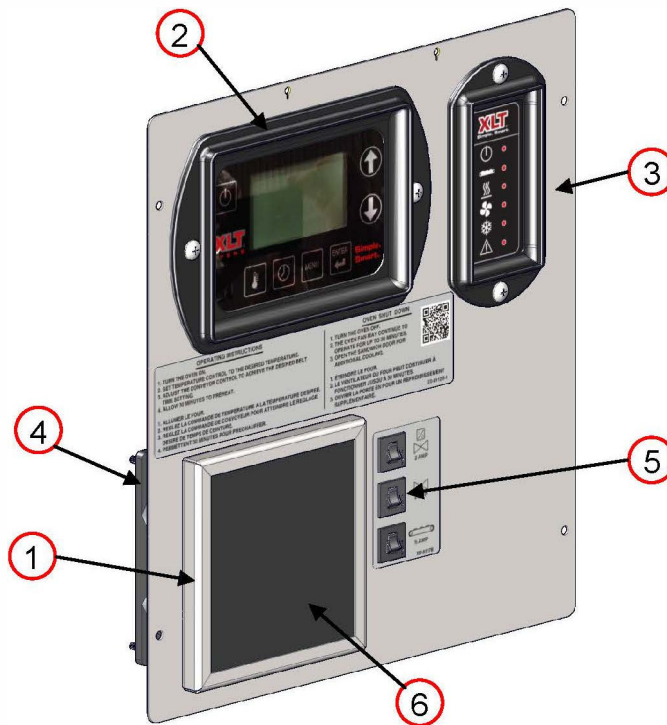

CONTROL PANEL			
ITEM	PART NUMBER	DESCRIPTION	YOUR PRICE
1	SP 4520-GA	Fan Guard / Filter Holder	\$5.60
2	XP 4170-LUI	Large User Interface	P.O.R
3	XP 4175-MC	Oven Control	P.O.R
4	XP 4501-W	FPPG Fan Standard M2	\$36.20
5	XP 4515-CB	Circuit Breaker	\$6.95
6	XP 4520-GA	Fan Filter	\$1.95

**Control Panel information required:**

- Size of Oven
- Voltage
- Circuit Breaker amp rating
- Conveyor Belt direction

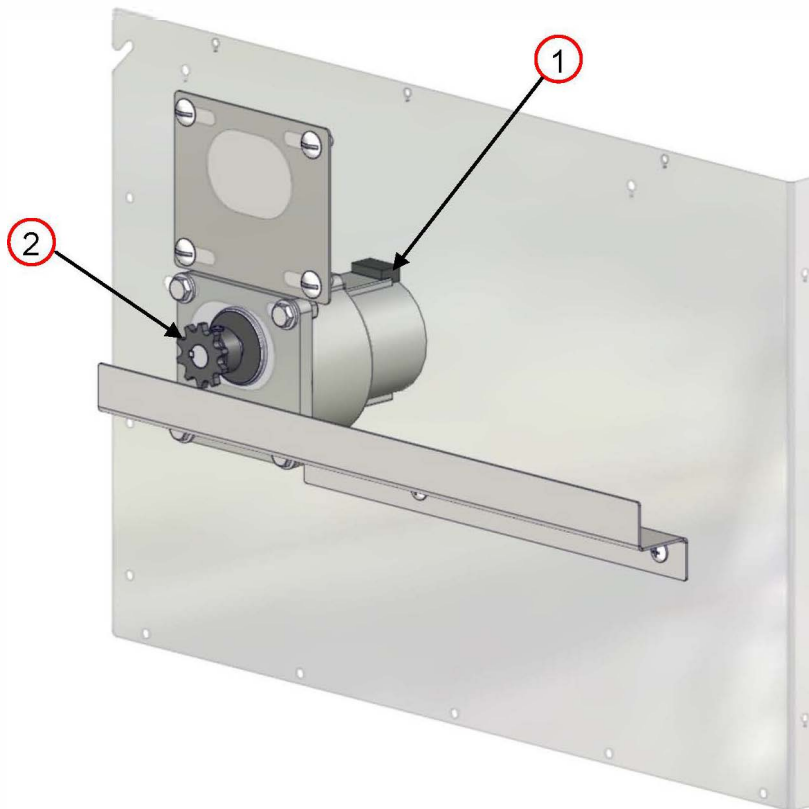

CONTROL BOX FRONT			
ITEM	PART NUMBER	DESCRIPTION	YOUR PRICE
1	XA 4117-12.5 RPM STD	Conv Motor Assy 12.5 RPM STD	\$305.30
2	XP 4155	Sprocket Conveyor Drive 10T	\$15.70

**Control Box Front information required:**

- Size of Oven
- Split Belt or Standard Belt

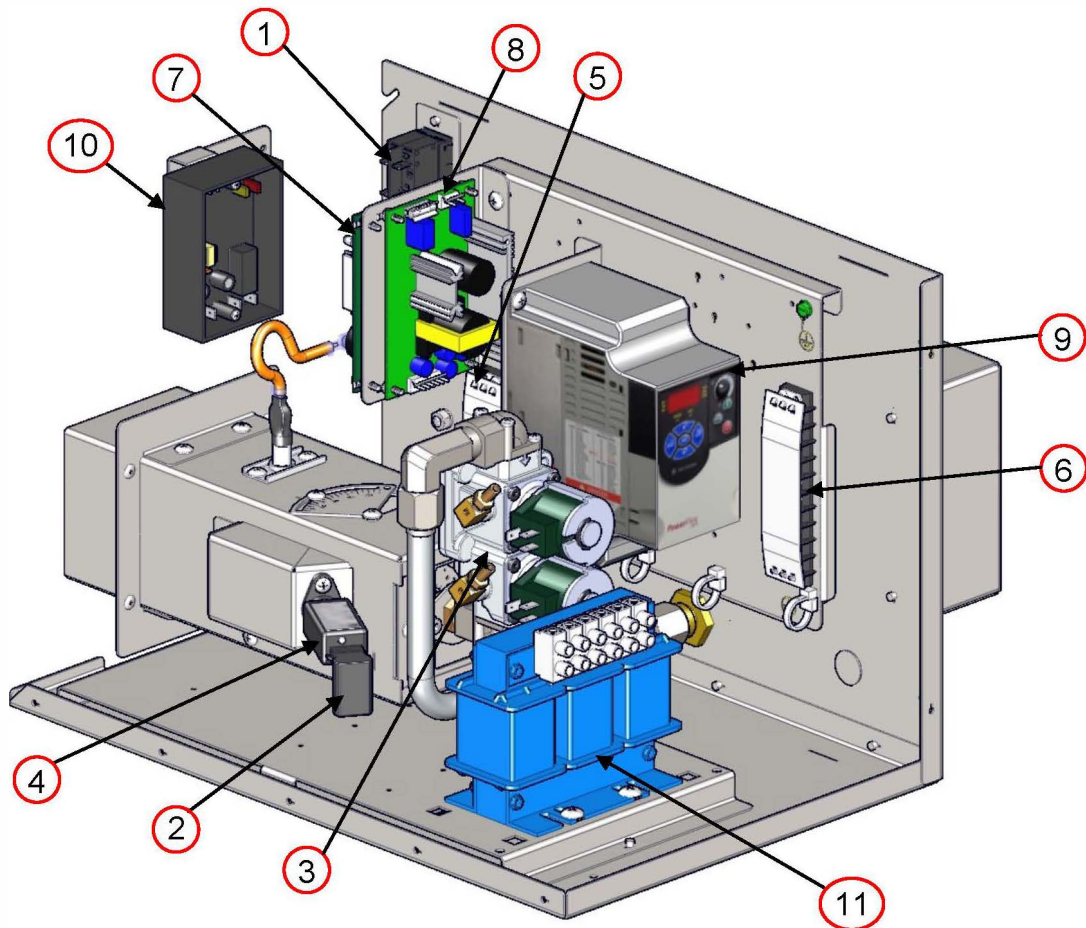

CONTROL BOX BACK			
ITEM	PART NUMBER	DESCRIPTION	YOUR PRICE
1	HP 2060	Circuit Breaker Exh Fan	P.O.R
2	XH 4211-DC	UV Flame Detector Wire Plug	\$11.46
3	XP 4207A-DI-N/P	On Off Valve	P.O.R
4	XP 4210-UV-DC	Flame Detector 24VDC	\$109.00
5	XP 4701A-04	Terminal Strip 4 Place	P.O.R
6	XP 4701A-10	Terminal Strip 10 Place	P.O.R
7	XP 4705A-DI-24	Ignition Control 24VDC	P.O.R
8	XP 4716	Power Supply PS	\$32.40
9	XP 4718-4.2	VFD Allen Bradley Power Flex 4M	P.O.R
10	XP 4720A-LS	Watlow LS High Temp Cont	P.O.R
11	XP 4721A	3 PH 3% Line Reactor	P.O.R

**Control Box Back information required:**

- Size of Oven
- Voltage

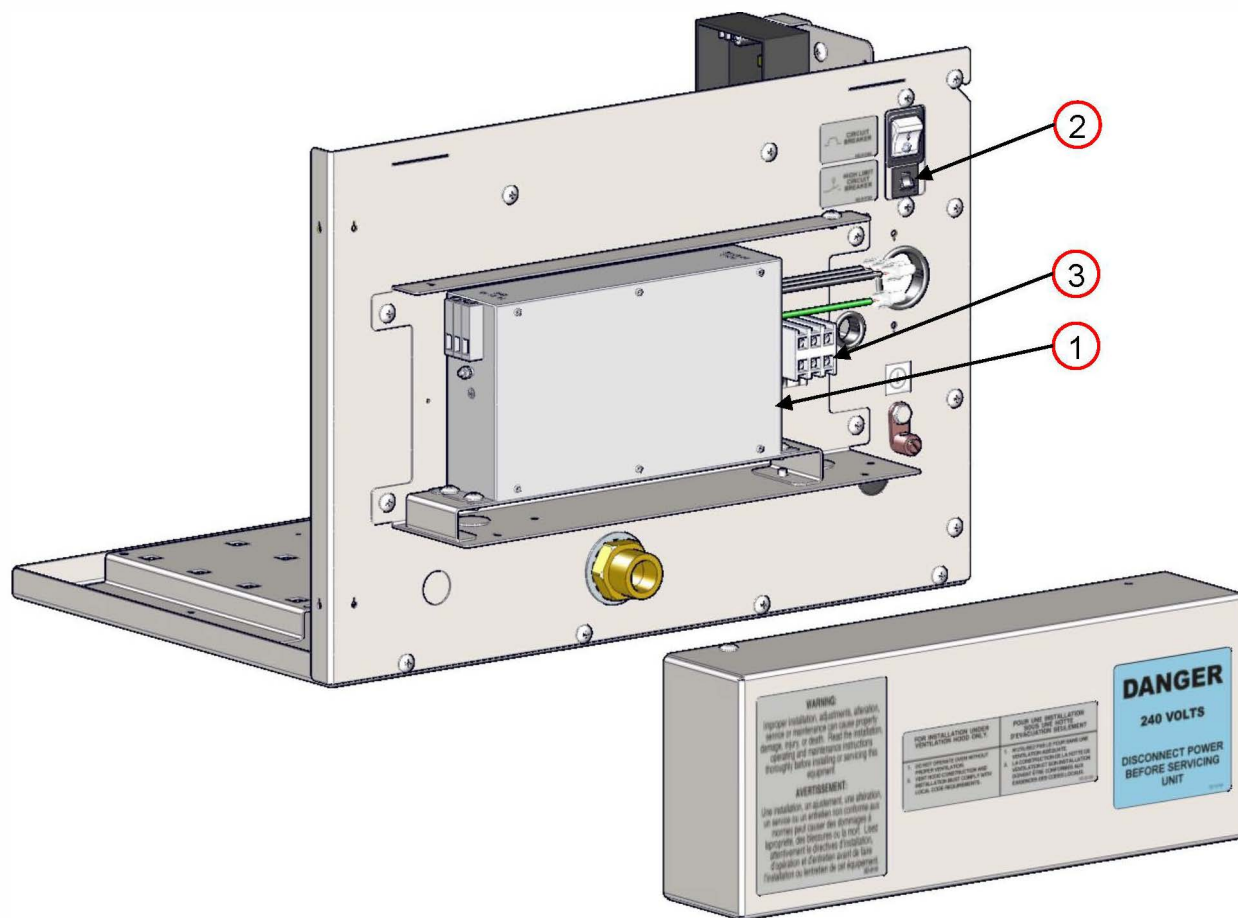

CONTROL BOX REAR			
ITEM	PART NUMBER	DESCRIPTION	YOUR PRICE
1	XP 4312A	EMC/RFI Filter	P.O.R
2	XP 4515-CB-0.5A	1/2 Amp Circuit Breaker	P.O.R
3	XP 4702-03-W	Terminal Block 3 Pole	P.O.R

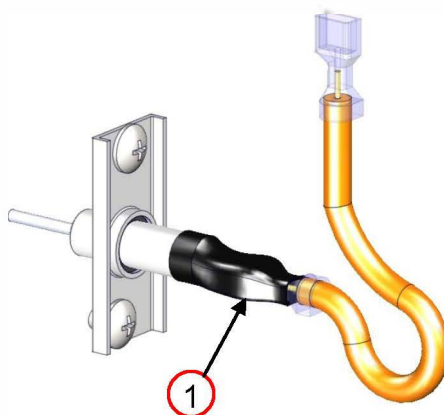

BURNER			
ITEM	PART NUMBER	DESCRIPTION	YOUR PRICE
1	XA 4203-DI-SQ	FS/SI Assembly	\$52.90

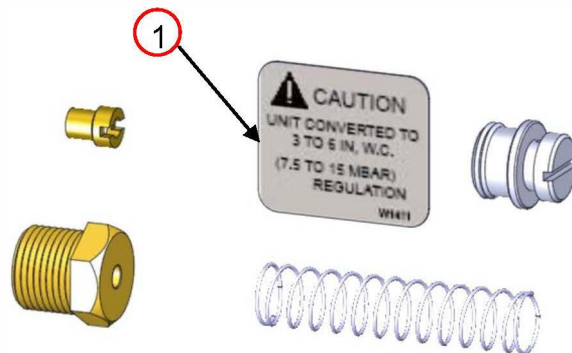

NATURAL GAS VALVE			
ITEM	PART NUMBER	DESCRIPTION	YOUR PRICE
1	SP 9910-QF-Nat	Natural Gas Conversion Kit	P.O.R

**Burner information required:**

- Size of Oven

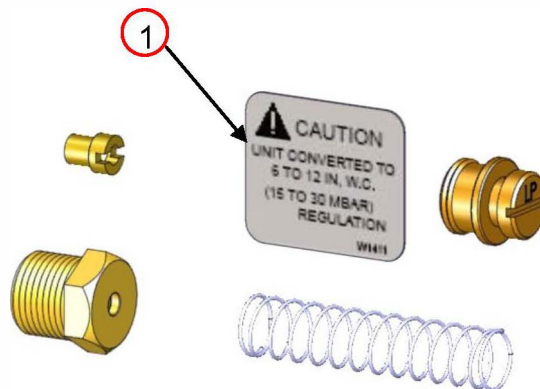

PROPANE VALVE			
ITEM	PART NUMBER	DESCRIPTION	YOUR PRICE
1	SP 9910-QF-Pro	Propane Conversion Kit	P.O.R

**Burner information required:**

- Size of Oven

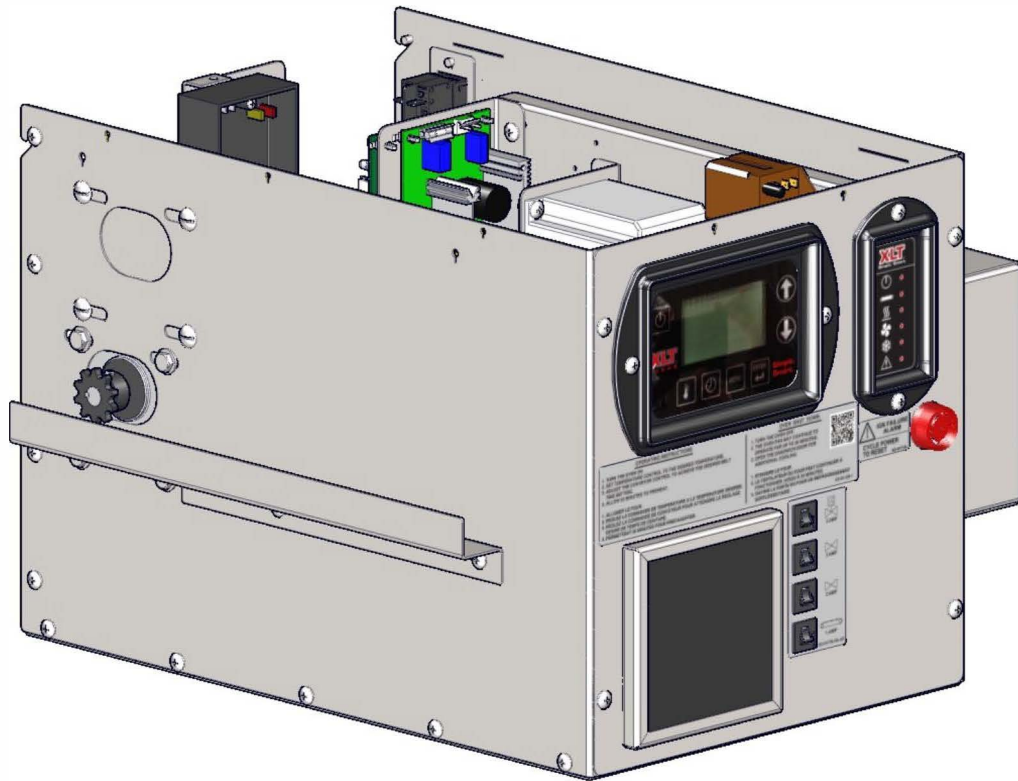

**Operating Position (shown with lid removed)**

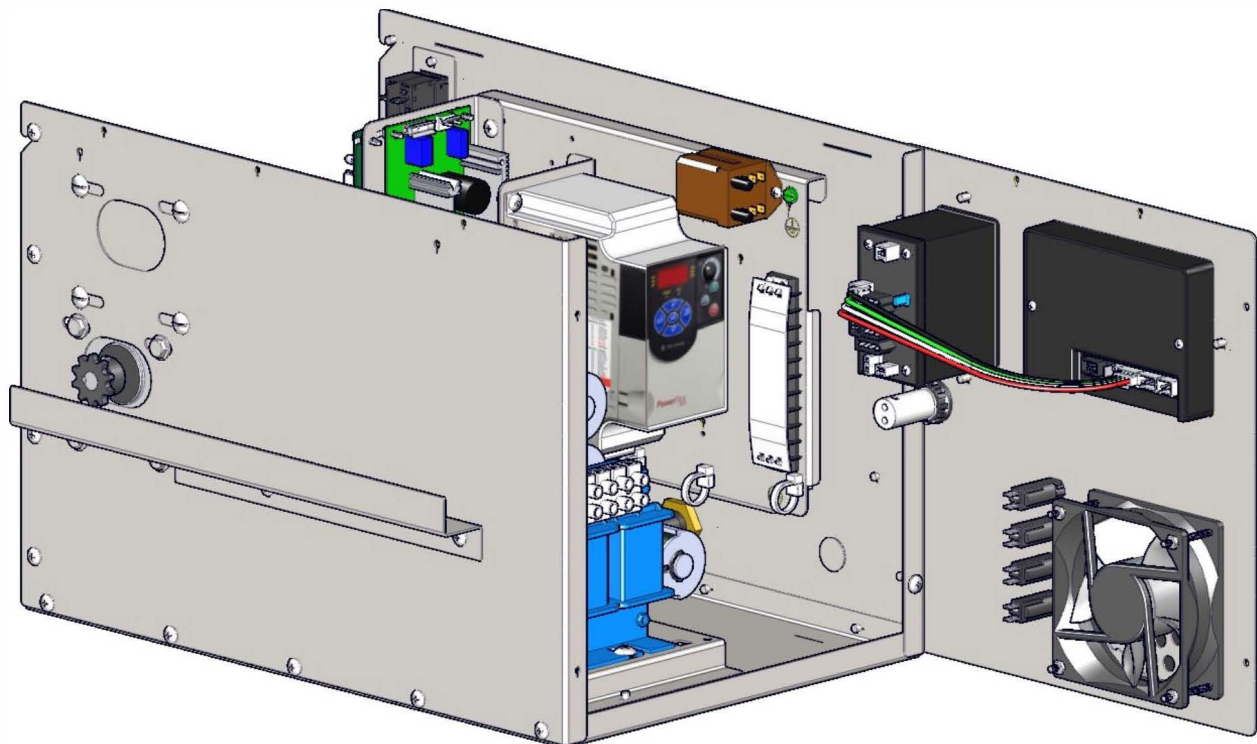

**Service Position**



CONTROL PANEL			
ITEM	PART NUMBER	DESCRIPTION	YOUR PRICE
1	SP 4520-GA	Fan Guard / Filter Holder	\$5.60
2	XP 4170-LUI	Large User Interface	P.O.R
3	XP 4175-MC	Oven Control	P.O.R
4	XP 4501-W	FPPG Fan Standard M2	\$36.20
5	XP 4515-CB	Circuit Breaker	\$6.95
6	XP 4520-GA	Fan Filter	\$1.95

**Control Panel information required:**

- Size of Oven
- Voltage
- Circuit Breaker amp rating
- Conveyor Belt direction

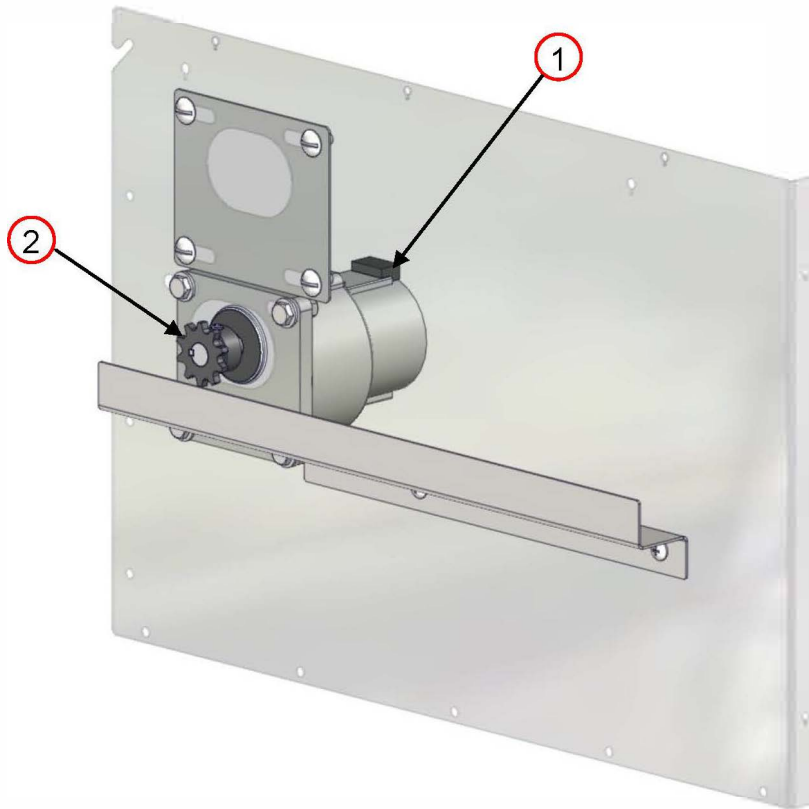

CONTROL BOX FRONT			
ITEM	PART NUMBER	DESCRIPTION	YOUR PRICE
1	XA 4117-12.5 RPM STD	Conv Motor Assy 12.5 RPM STD	\$305.30
2	XP 4155	Sprocket Conveyor Drive 10T	\$15.70

**Control Box Front information required:**

- Size of Oven
- Split Belt or Standard Belt

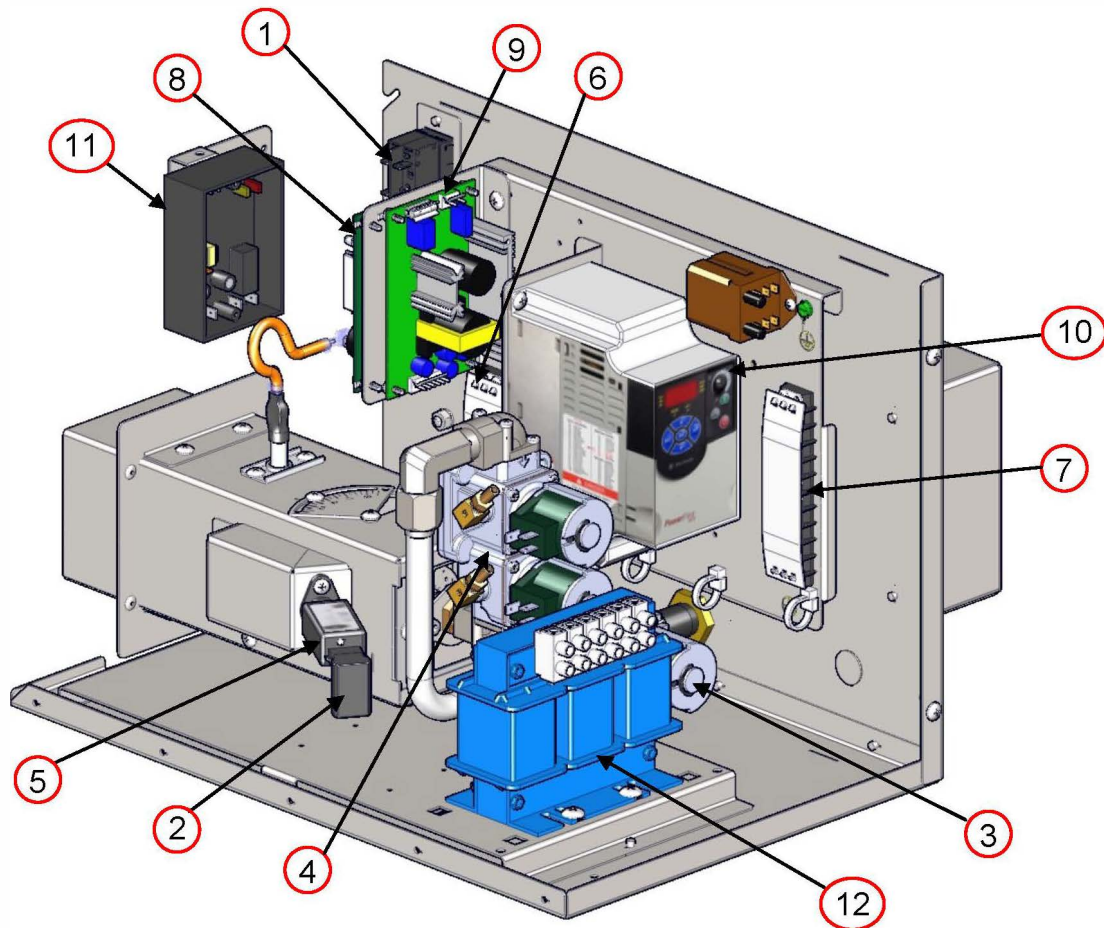

CONTROL BOX BACK			
ITEM	PART NUMBER	DESCRIPTION	YOUR PRICE
1	HP 2060	Circuit Breaker Exh Fan	P.O.R
2	XH 4211-DC	UV Flame Detector Wire Plug	\$11.46
3	XP 4207A-DI-AE	Shut-Off Valve	P.O.R
4	XP 4207A-DI-N/P	On Off Valve	P.O.R
5	XP 4210-UV-DC	Flame Detector 24VDC	\$109.00
6	XP 4701A-04	Terminal Strip 4 Place	P.O.R
7	XP 4701A-10	Terminal Strip 10 Place	P.O.R
8	XP 4705A-DI-24	Ignition Control 24VDC	P.O.R
9	XP 4716	Power Supply PS	\$32.40
10	XP 4718-4.2	VFD Allen Bradley Power Flex 4M	P.O.R
11	XP 4720A-LS	Watlow LS High Temp Cont	P.O.R
12	XP 4721A	3 PH 3% Line Reactor	P.O.R

**Control Box Back information required:**

- Size of Oven
- Voltage

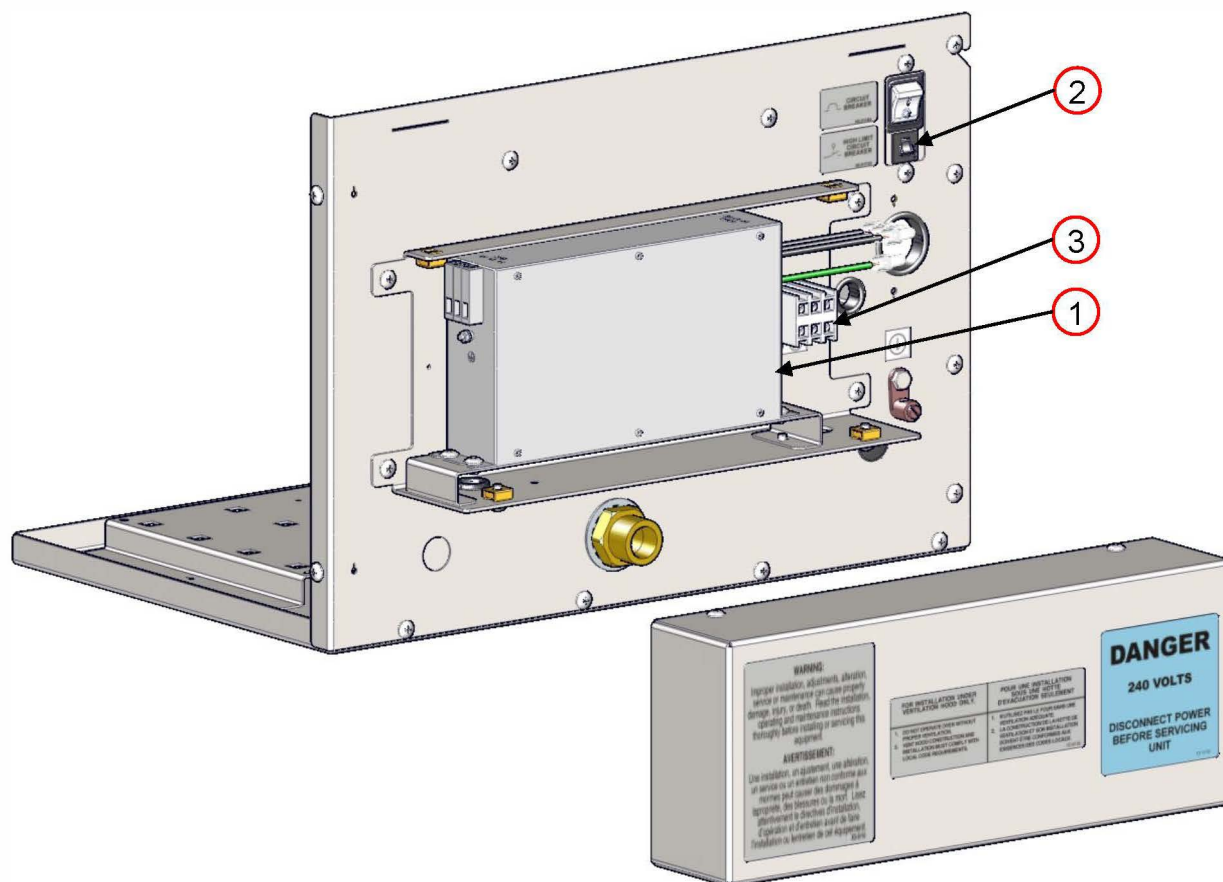

CONTROL BOX REAR			
ITEM	PART NUMBER	DESCRIPTION	YOUR PRICE
1	XP 4312A	EMC/RFI Filter	P.O.R
2	XP 4515-CB-0.5A	1/2 Amp Circuit Breaker	P.O.R
3	XP 4702-03-W	Terminal Block 3 Pole	P.O.R

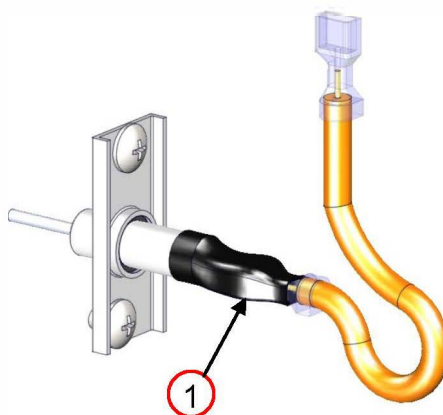

BURNER			
ITEM	PART NUMBER	DESCRIPTION	YOUR PRICE
1	XA 4203-DI-SQ	FS/SI Assembly	\$52.90

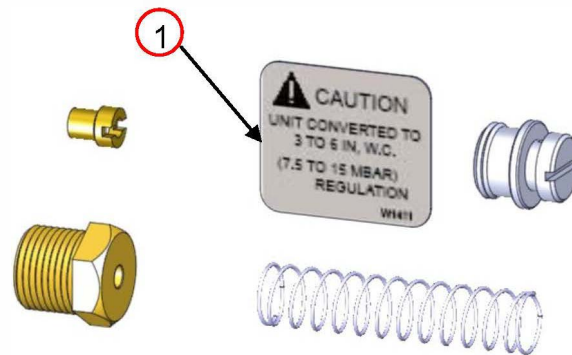

NATURAL GAS VALVE			
ITEM	PART NUMBER	DESCRIPTION	YOUR PRICE
1	SP 9910-QF-Nat	Natural Gas Conversion Kit	P.O.R

**Burner information required:**

- Size of Oven

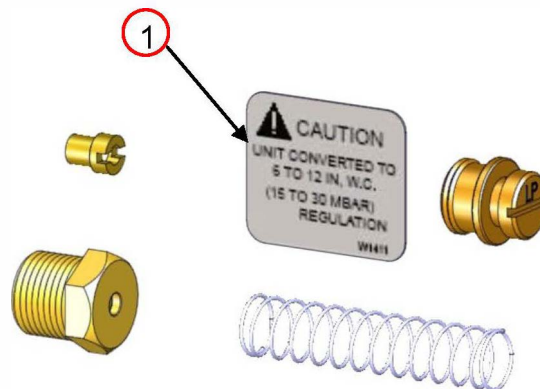

PROPANE VALVE			
ITEM	PART NUMBER	DESCRIPTION	YOUR PRICE
1	SP 9910-QF-Pro	Propane Conversion Kit	P.O.R

**Burner information required:**

- Size of Oven

This page intentionally left blank.

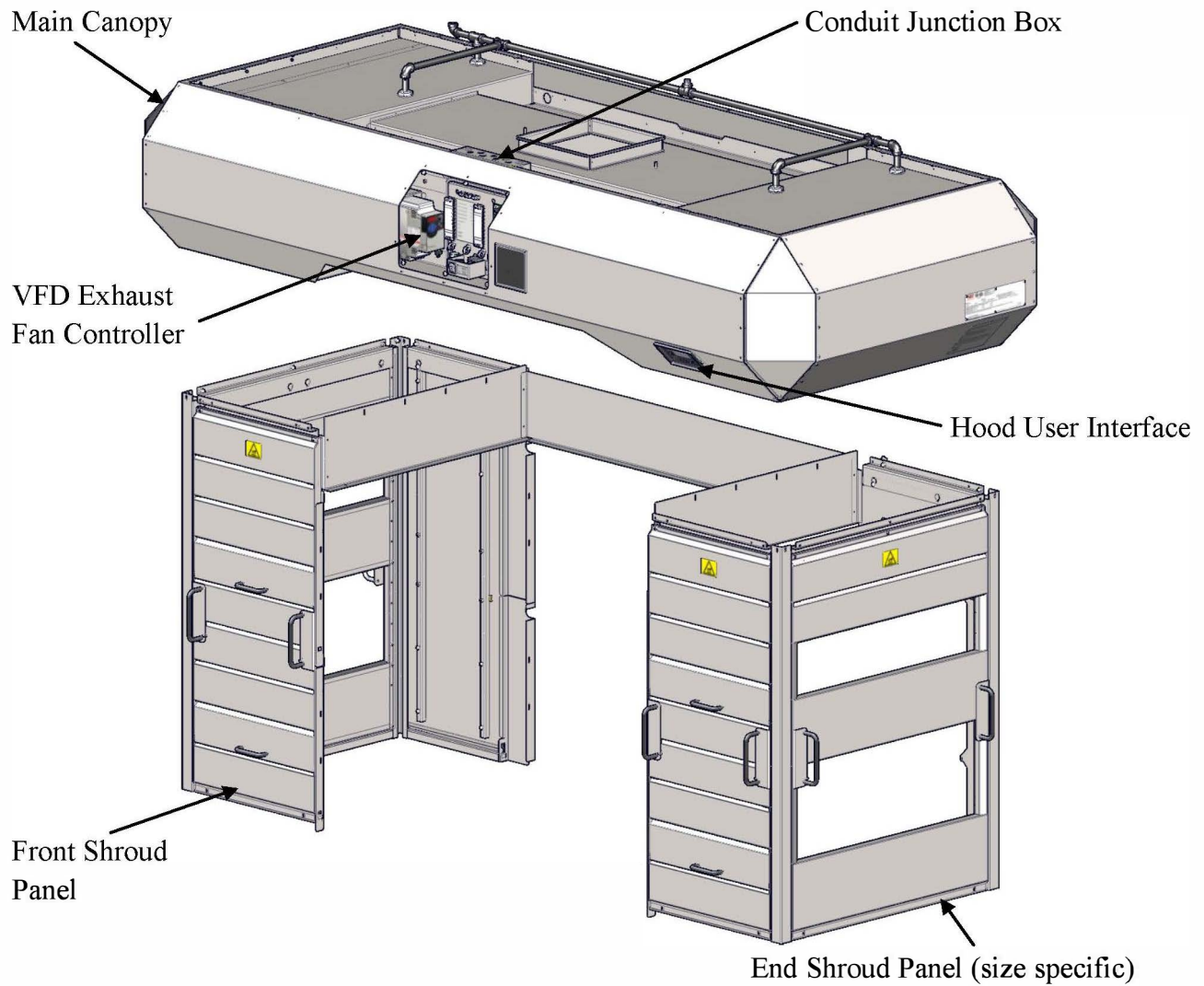

VFD Control Box w/Fire Suppression

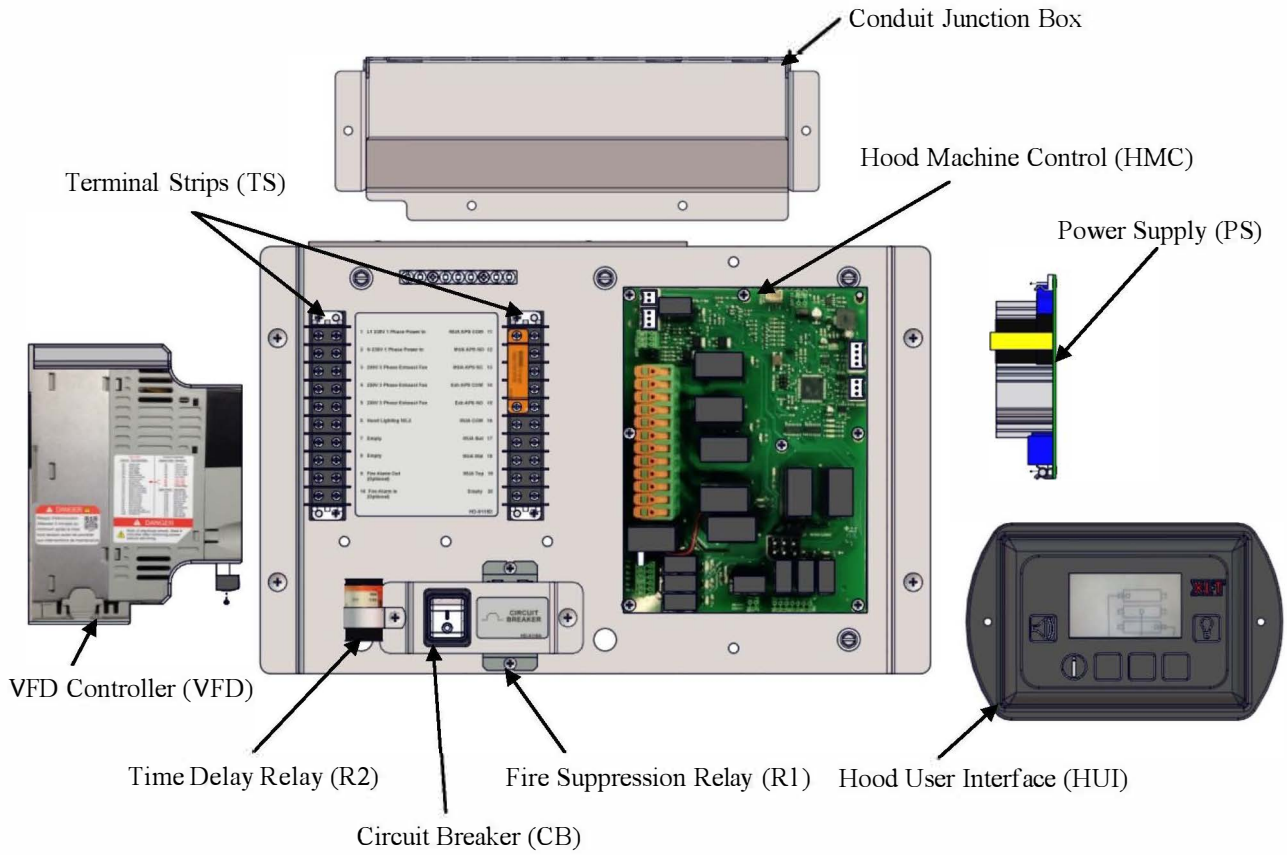

VFD Control Box (Cover removed)

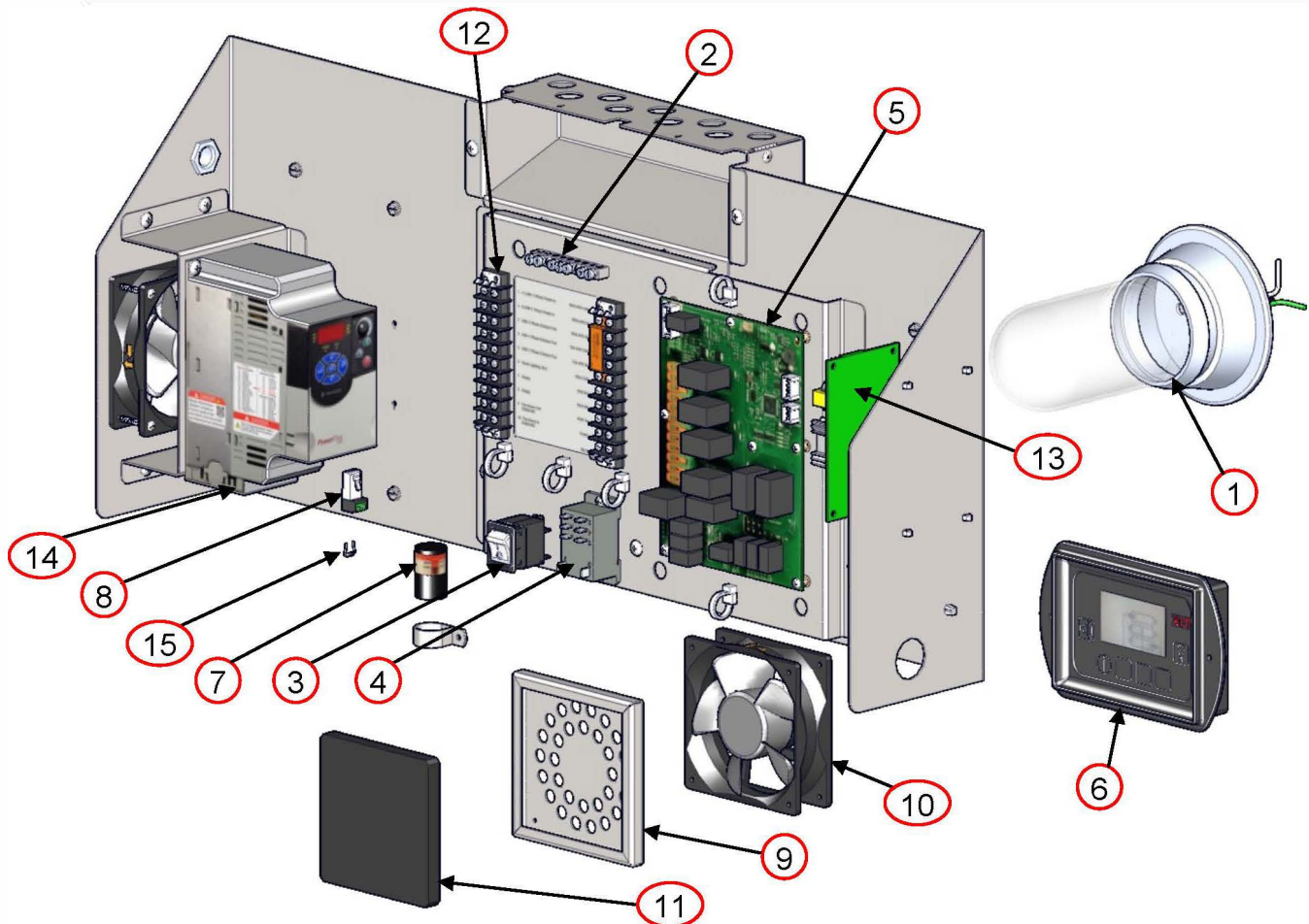

VFD W/ FIRE SUPPRESSION			
ITEM	PART NUMBER	DESCRIPTION	YOUR PRICE
1	HP-1251	Light Assembly	\$57.80
2	HP-2058	Ground Bar 7 POS	\$55.70
3	HP-2060	Circuit Breaker Exhaust Fan	\$52.30
4	HP-2067-24VDC	Relay 8 Pin 30A 24 VDC	\$23.70
5	HP-2070-MC	Hood Machine Control	P.O.R
6	HP-2071-UI	Hood User Interface	P.O.R
7	HP-2072	Time Delay Relay R2	P.O.R
8	HP-4718-RJ45	RJ45 Terminal Block	\$2.30
9	SP-4520-GA	Fan Guard / Filter Repl Kit GA	\$5.60
10	XP-4501-GA	FPPG Fan Gas M2	P.O.R
11	XP-4520-GA	Fan Filter	\$1.95
12	XP-4701-10	Terminal Strip 10 Place	\$7.00
13	XP-4716	Power Supply	\$32.40
14	XP-4718-4.2	VFD Allen Bradley Power Flex 4M	P.O.R
15	XW-2900	120 Ohm Terminating Resistor	P.O.R

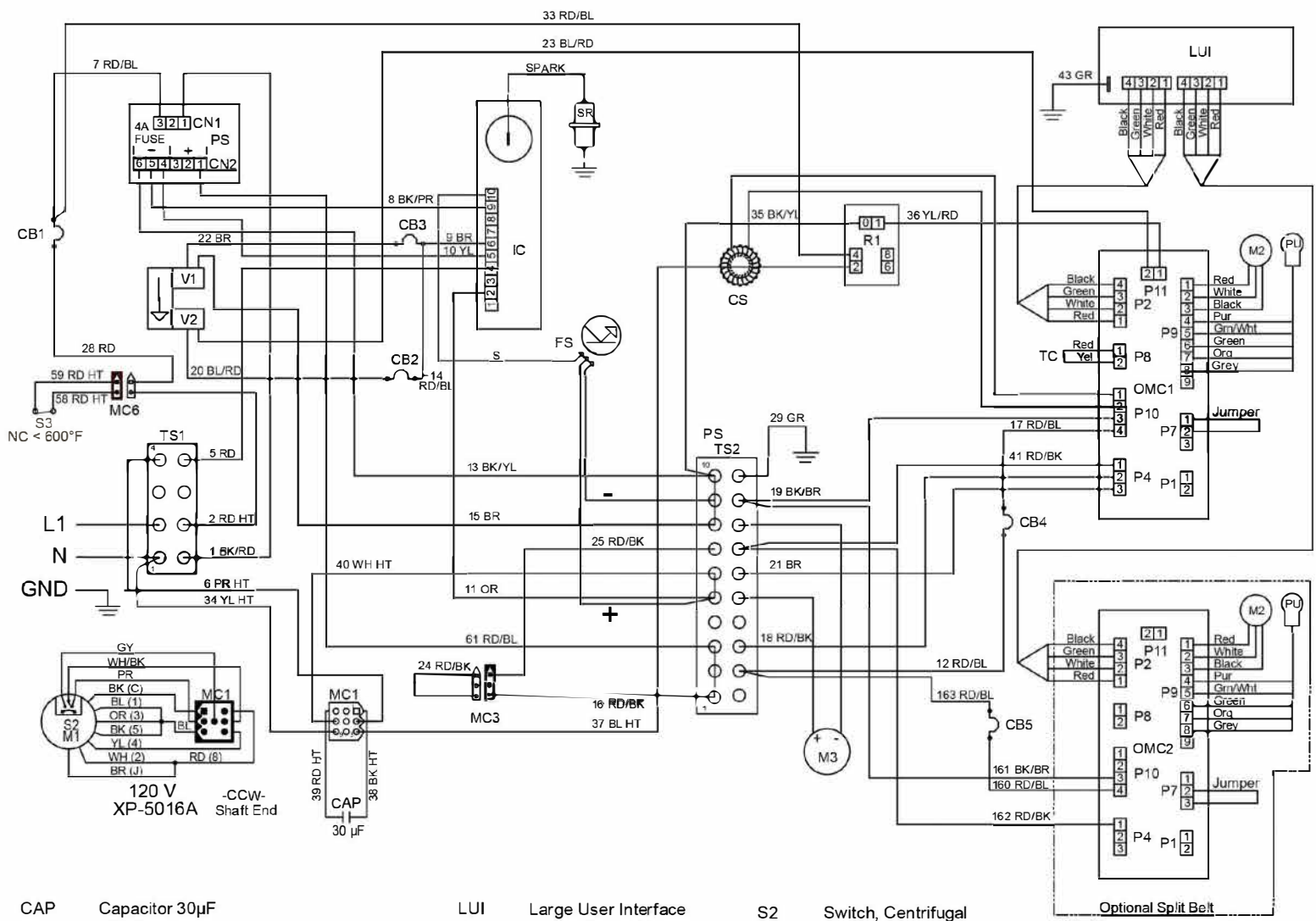

Technical Support US: 888-443-2751



Technical Support INTL: 316-943-2751

- |           |   |           |                          |          |                     |
|-----------|---|-----------|--------------------------|----------|---------------------|
| CAP       | Capacitor 30µF                            | LUI       | Large User Interface     | S2       | Switch, Centrifugal |
| CB1       | Circuit Breaker, 15 Amp, Main             | M1        | Motor, Oven Fan          | S3       | Switch, High Limit  |
| CB2       | Circuit Breaker, 2 Amp, Gas Valve, HI/Low | M2        | Motor, Conveyor          | SR       | Spark Rod           |
| CB3       | Circuit Breaker, 2 Amp, Gas Valve, ON/OFF | M3        | Motor, FPPG              | TC       | Thermocouple        |
| CB4       | Circuit Breaker, 1/2 Amp, Conveyor Motor  | OMC1      | Oven Control, Main       | TS1      | Terminal Strip      |
| CB5       | Circuit Breaker, 1/2 Amp, Conveyor Motor  | OMC2      | Oven Control, Split Belt | TS2      | Terminal Strip      |
| CS        | Current Sensor                            | PS        | Power Supply             | V1       | Gas Valve ON/OFF    |
| FS        | Flame Sense                               | PU        | Pick-Up                  | V2       | Gas Valve HI/LOW    |
| IC        | Ignition Control                          | R1        | Oven Fan Motor Relay     |          |                     |
| RD-Red    | BK-Black                                  | BL-Blue   | BR-Brown                 | GR-Green | YL-Yellow           |
| PR-Purple | HT-High Temp                              | OR-Orange | WH-White                 | GY-Gray  |                     |

- X3F-1832
- X3F-2440
- X3F-3240
- X3F-3255
- X3F-3855

120 VAC 1 PH 60 Hz  
 XD-9130F-GA-S 1B  
 Right Side  
 02/27/2017

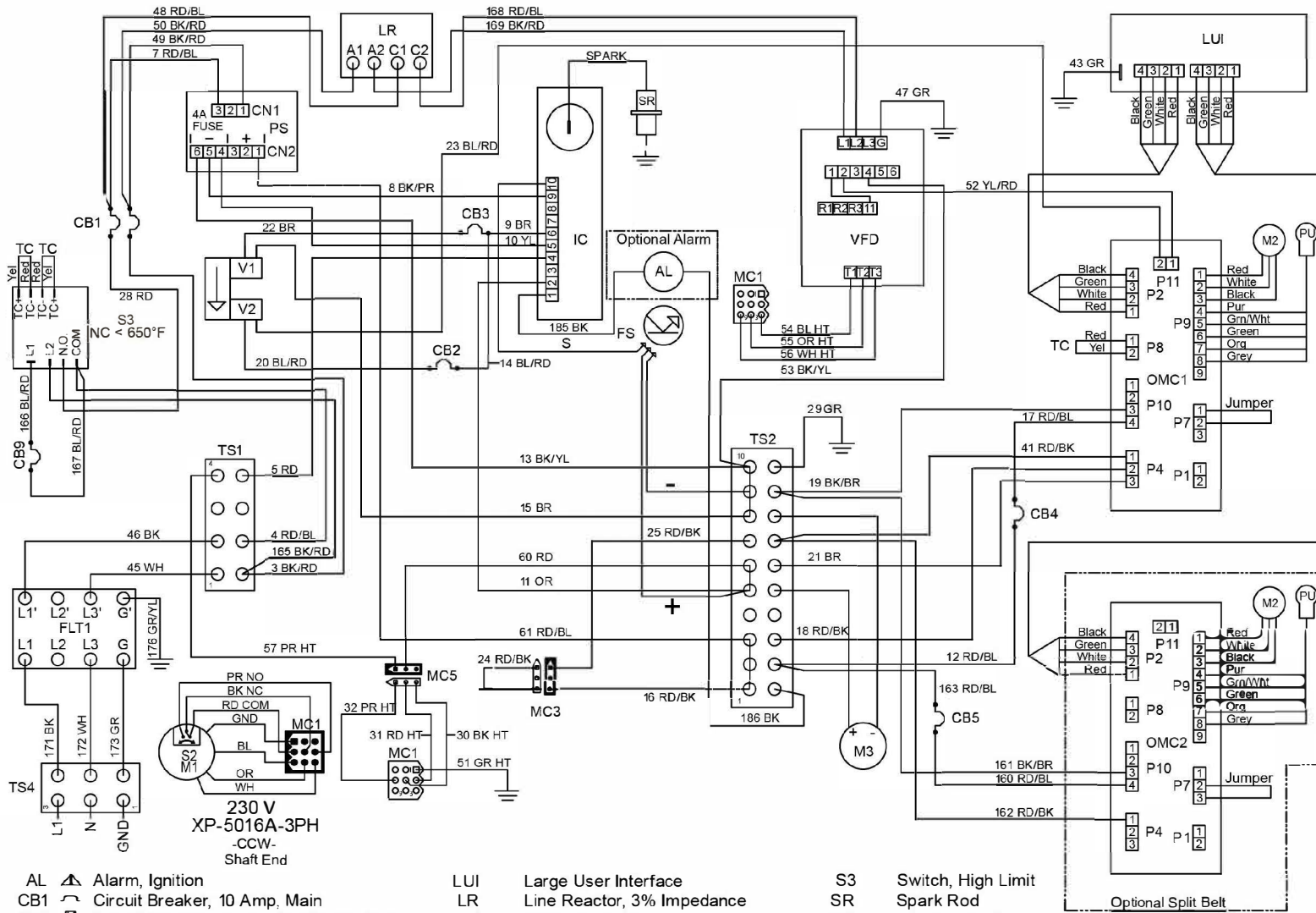

- AL Alarm, Ignition
- CB1 Circuit Breaker, 10 Amp, Main
- CB2 Circuit Breaker, 2 Amp, Gas Valve, HI/Low
- CB3 Circuit Breaker, 2 Amp, Gas Valve, ON/OFF
- CB4 Circuit Breaker, 1/2 Amp, Conveyor Motor
- CB5 Circuit Breaker, 1/2 Amp, Conveyor Motor
- CB9 Circuit Breaker, 1/2 Amp, High Limit
- FLT1 Power Filter, EMI
- FS Flame Sense
- IC Ignition Control
- LUI Large User Interface
- LR Line Reactor, 3% Impedance
- M1 Motor, Oven Fan
- M2 Motor, Conveyor
- M3 Motor, FPPG
- OMC1 Oven Control, Main
- OMC2 Oven Control, Split Belt & 2nd Burner
- PS Power Supply
- PU Pick-Up
- S2 Switch, Centrifugal

- S3 Switch, High Limit
- SR Spark Rod
- TC Thermocouple
- TS1 Terminal Strip
- TS2 Terminal Strip
- TS4 Terminal Strip
- VFD Oven Fan Motor Frequency Drive
- V1 Gas Valve ON/OFF
- V2 Gas Valve HI/LOW

RD-Red BK-Black BL-Blue BR-Brown GR-Green YL-Yellow PR-Purple HT-High Temp OR-Orange WH-White GY-Gray

- X3F-1832
- X3F-2440
- X3F-3240
- X3F-3255
- X3F-3855

230 VAC 1 PH 50 Hz  
 XD-9130F-GA-W 1B  
 Right Side  
 02/27/2017

Technical Support US: 888-443-2751



Technical Support INTL: 316-943-2751

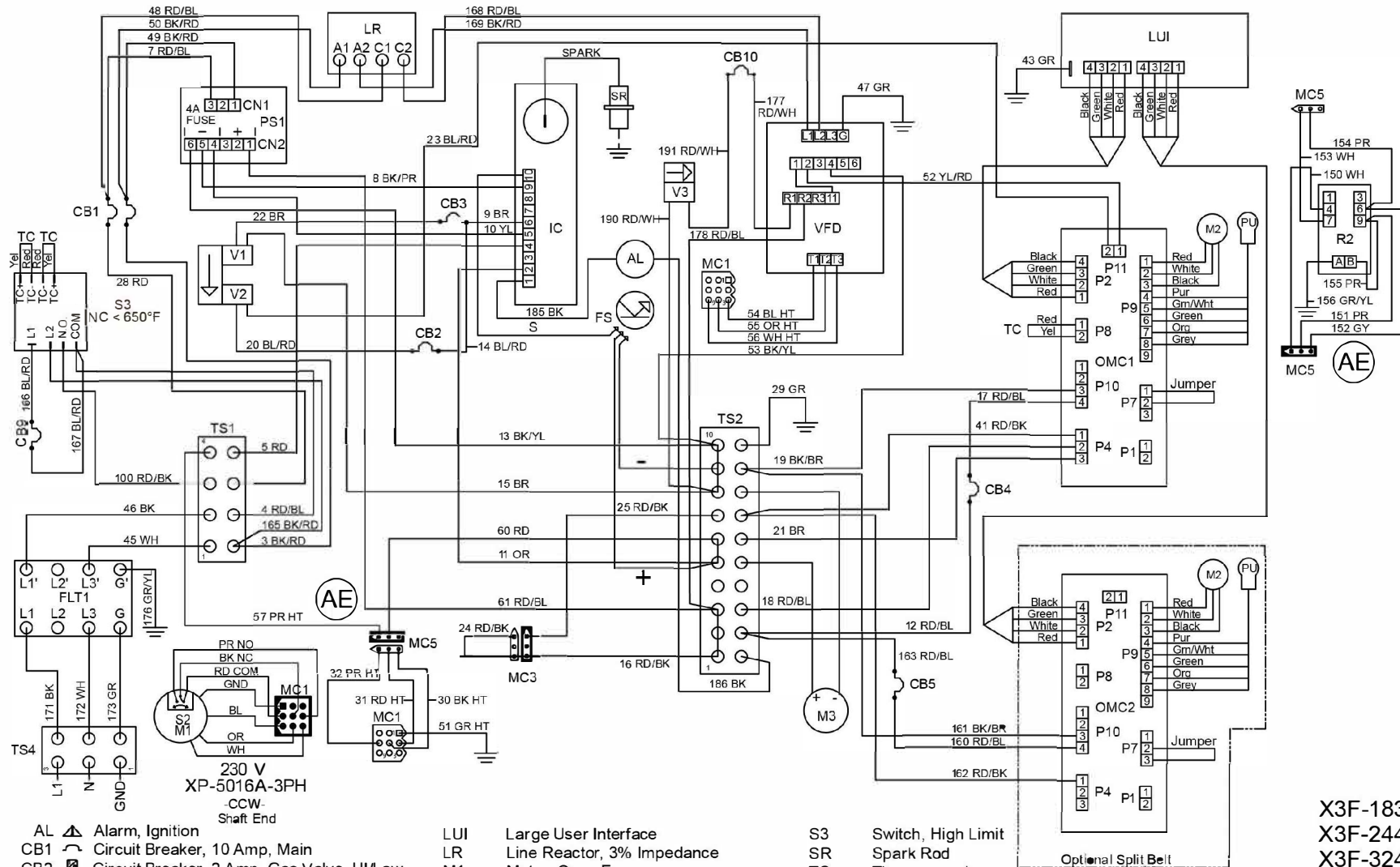

- |        |   |         |                                       |              |                                |
|--------|---|---------|---------------------------------------|--------------|--------------------------------|
| AL     | Alarm, Ignition                             | LUI     | Large User Interface                  | S3           | Switch, High Limit             |
| CB1    | Circuit Breaker, 10 Amp, Main               | LR      | Line Reactor, 3% Impedance            | SR           | Spark Rod                      |
| CB2    | Circuit Breaker, 2 Amp, Gas Valve, HI/LOW   | M1      | Motor, Oven Fan                       | TC           | Thermocouple                   |
| CB3    | Circuit Breaker, 2 Amp, Gas Valve, ON/OFF   | M2      | Motor, Conveyor                       | TS1          | Terminal Strip                 |
| CB4    | Circuit Breaker, 1/2 Amp, Conveyor Motor    | M3      | Motor, FPPG                           | TS2          | Terminal Strip                 |
| CB5    | Circuit Breaker, 1/2 Amp, Conveyor Motor    | OMC1    | Oven Control, Main                    | TS4          | Terminal Strip                 |
| CB9    | Circuit Breaker, 1/2 Amp, High Limit        | OMC2    | Oven Control, Split Belt & 2nd Burner | VFD          | Oven Fan Motor Frequency Drive |
| CB10   | Circuit Breaker, 2 Amp, Gas Valve, Shut-Off | PS1     | Power Supply                          | V1           | Gas Valve ON/OFF               |
| FLT1   | Power Filter, EMI                           | PU      | Pick-Up                               | V2           | Gas Valve HI/LOW               |
| FS     | Flame Sense                                 | R2      | Proving Relay                         | V3           | Gas Valve ON/OFF, Shut-Off     |
| IC     | Ignition Control                            | S2      | Switch, Centrifugal                   |              |                                |
| RD-Red | BK-Black                                    | BL-Blue | BR-Brown                              | GR-Green     | YL-Yellow                      |
|        |   |         | PR-Purple                             | HT-High Temp | OR-Orange                      |
|        |   |         |                                       | WH-White     | GY-Gray                        |

- X3F-1832
- X3F-2440
- X3F-3240
- X3F-3255
- X3F-3855

230 VAC 1 PH 50 Hz  
 XD-9130F-GA-AE 1B  
 Right Side  
 02/27/2017

This page intentionally left blank.



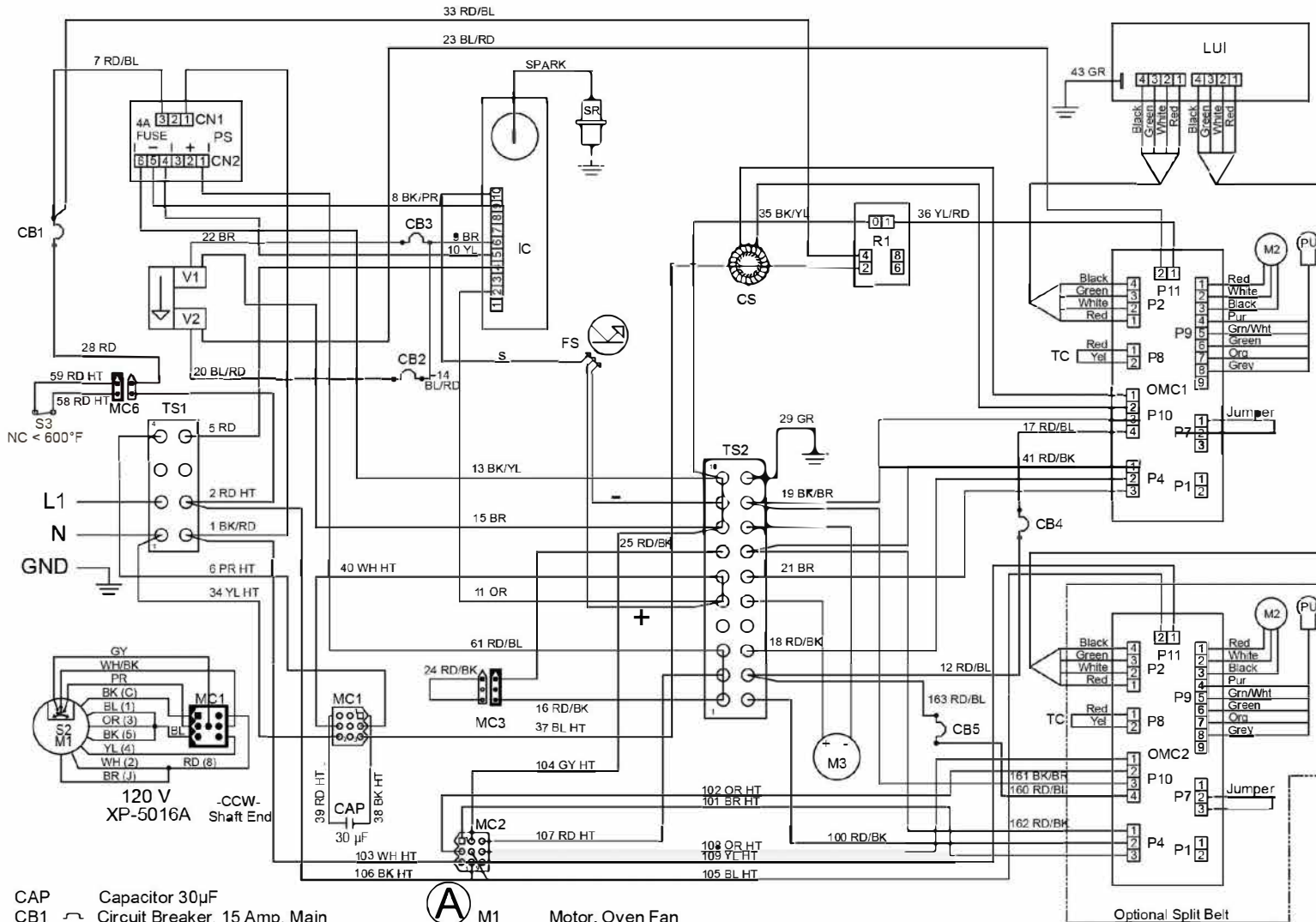

- CAP Capacitor 30µF
- CB1 Circuit Breaker, 15 Amp, Main
- CB2 Circuit Breaker, 2 Amp, Gas Valve, HI/Low
- CB3 Circuit Breaker, 2 Amp, Gas Valve, ON/OFF
- CB4 Circuit Breaker, 1/2 Amp, Conveyor Motor
- CB5 Circuit Breaker, 1/2 Amp, Conveyor Motor
- CS Current Sensor
- FS Flame Sense
- IC Ignition Control
- LUI Large User Interface
- RD-Red BK-Black BL-Blue BR-Brown GR-Green YL-Yellow PR-Purple HT-High Temp OR-Orange WH-White GY-Gray

- M1 Motor, Oven Fan
- M2 Motor, Conveyor
- M3 Motor, FPPG
- OMC1 Oven Control, Main
- OMC2 Oven Control, Split Belt & 2nd Burner
- PS Power Supply
- PU Pick-Up
- R1 Oven Fan Motor Relay
- REC1 Receptacle, Power

- S2 Switch, Centrifugal
- S3 Switch, High Limit
- SR Spark Rod
- TC Thermocouple
- TS1 Terminal Strip
- TS2 Terminal Strip
- V1 Gas Valve ON/OFF
- V2 Gas Valve HI/LOW

X3F-3270-2B  
X3F-3870-2B

120 VAC 1 PH 60 Hz  
XD-9130F-GA-S 2B

Right Side  
02/27/2017

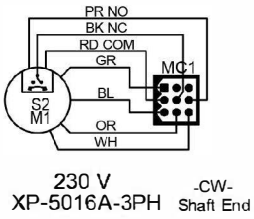
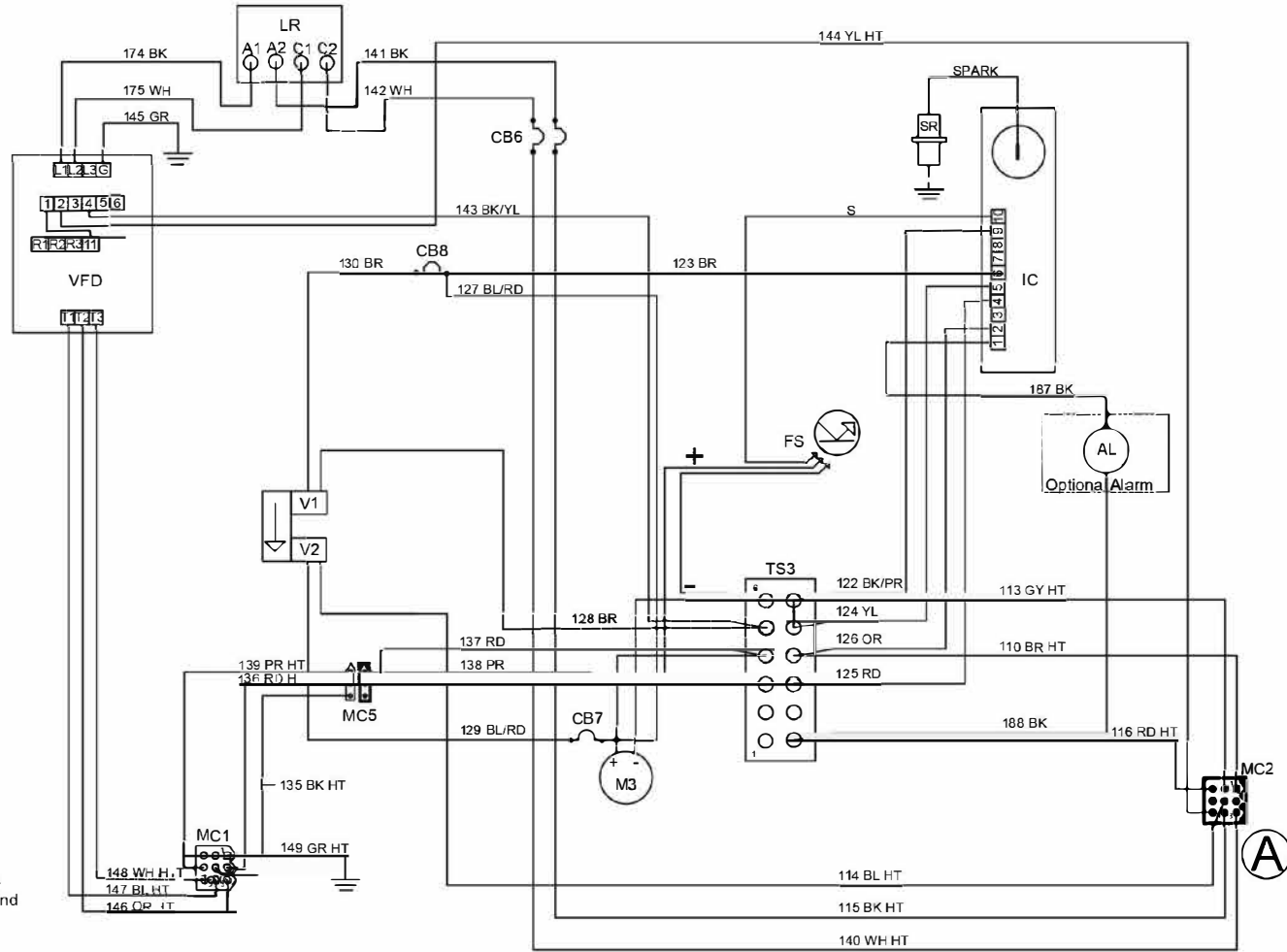

X3F-3270-2B  
X3F-3870-2B

230 VAC 1 PH 50 Hz  
XD-9130F-GA-W 2B  
Left Side  
02/27/2017

- |     |   |    |                            |     |                                |
|-----|---|----|----------------------------|-----|--------------------------------|
| AL  | ▲ Alarm, Ignition                           | LR | Line Reactor, 3% Impedance | SR  | Spark Rod                      |
| CB6 | ⌋ Circuit Breaker, 10 Amp, Main             | M1 | Motor, Oven Fan            | TS3 | Terminal Strip                 |
| CB7 | ⌋ Circuit Breaker, 2 Amp, Gas Valve, HI/Low | M3 | Motor, FPPG                | VFD | Oven Fan Motor Frequency Drive |
| CB8 | ⌋ Circuit Breaker, 2 Amp, Gas Valve, ON/OFF | R2 | Proving Relay              | V1  | Gas Valve ON/OFF               |
| FS  | Flame Sense                                 | S2 | Switch, Centrifugal        | V2  | Gas Valve HI/LOW               |
| IC  | Ignition Control                            |    |                            |     |                                |

RD-Red BK-Black BL-Blue BR-Brown GR-Green YL-Yellow PR-Purple HT-High Temp OR-Orange WH-White GY-Gray

Technical Support US: 888-443-2751



Technical Support INTL: 316-943-2751

Technical Support US: 888-443-2751



Technical Support INTL: 316-943-2751

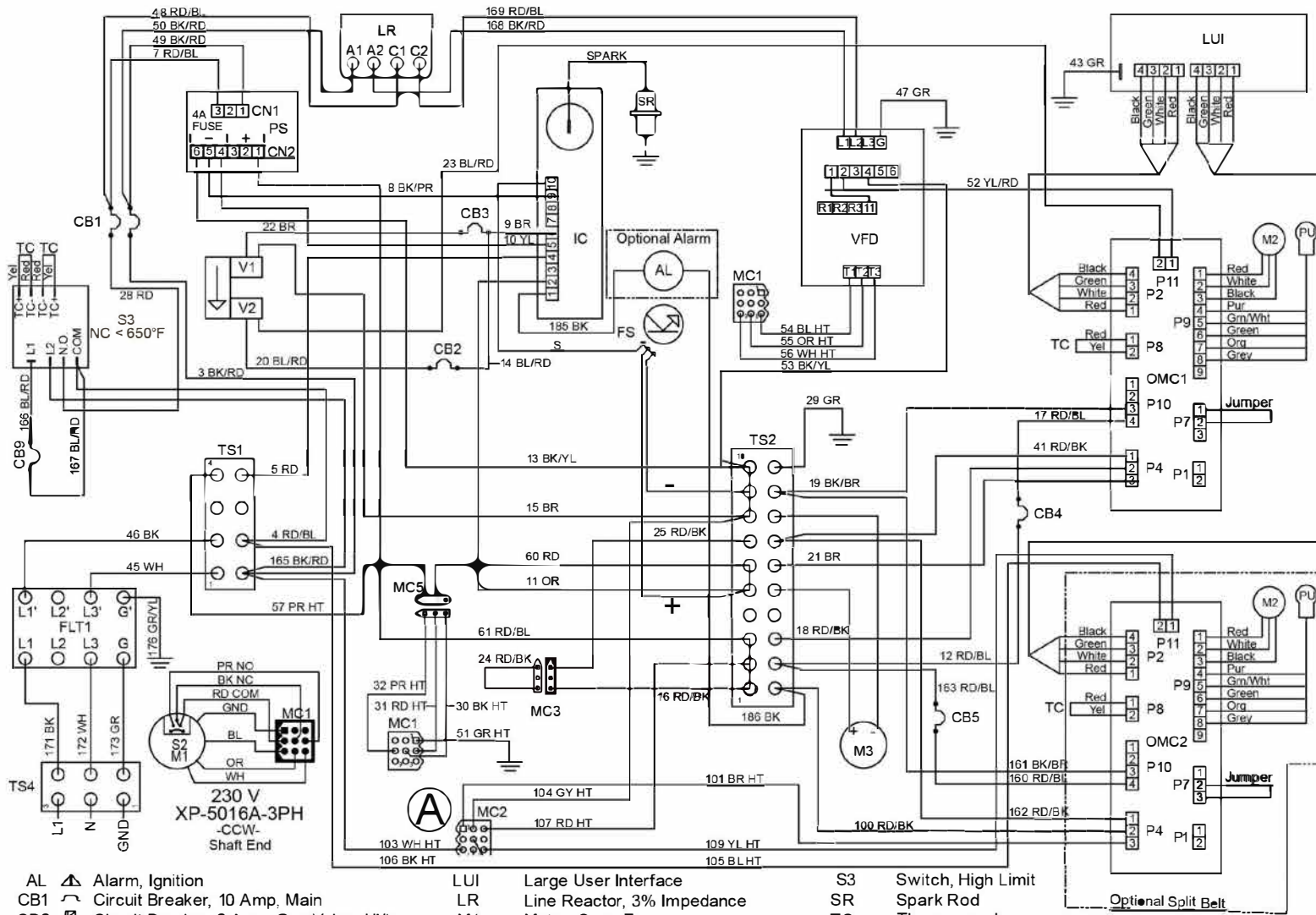

- |           |   |           |                                       |          |                                |
|-----------|---|-----------|---------------------------------------|----------|--------------------------------|
| AL        | Alarm, Ignition                           | LUI       | Large User Interface                  | S3       | Switch, High Limit             |
| CB1       | Circuit Breaker, 10 Amp, Main             | LR        | Line Reactor, 3% Impedance            | SR       | Spark Rod                      |
| CB2       | Circuit Breaker, 2 Amp, Gas Valve, HI/Low | M1        | Motor, Oven Fan                       | TC       | Thermocouple                   |
| CB3       | Circuit Breaker, 2 Amp, Gas Valve, ON/OFF | M2        | Motor, Conveyor                       | TS1      | Terminal Strip                 |
| CB4       | Circuit Breaker, 1/2 Amp, Conveyor Motor  | M3        | Motor, FPPG                           | TS2      | Terminal Strip                 |
| CB5       | Circuit Breaker, 1/2 Amp, Conveyor Motor  | OMC1      | Oven Control, Main                    | TS4      | Terminal Strip                 |
| CB9       | Circuit Breaker, 1/2 Amp, High Limit      | OMC2      | Oven Control, Split Belt & 2nd Burner | VFD      | Oven Fan Motor Frequency Drive |
| FLT1      | Power Filter, EMI                         | PS        | Power Supply                          | V1       | Gas Valve ON/OFF               |
| FS        | Flame Sense                               | PU        | Pick-Up                               | V2       | Gas Valve HI/LOW               |
| IC        | Ignition Control                          | S2        | Switch, Centrifugal                   |          |                                |
| RD-Red    | BK-Black                                  | BL-Blue   | BR-Brown                              | GR-Green | YL-Yellow                      |
| PR-Purple | HT-High Temp                              | OR-Orange | WH-White                              | GY-Gray  |                                |

X3F-3270-2B  
X3F-3870-2B

230 VAC 1 PH 50 Hz  
XD-9130F-GA-W 2B  
Right Side  
02/27/2017

OVEN SCHEMATIC - WORLD 2 BOX RH 230 VAC

Technical Support US: 888-443-2751



Technical Support INTL: 316-943-2751

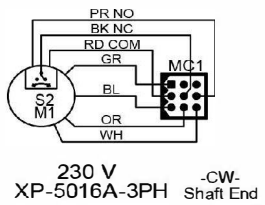
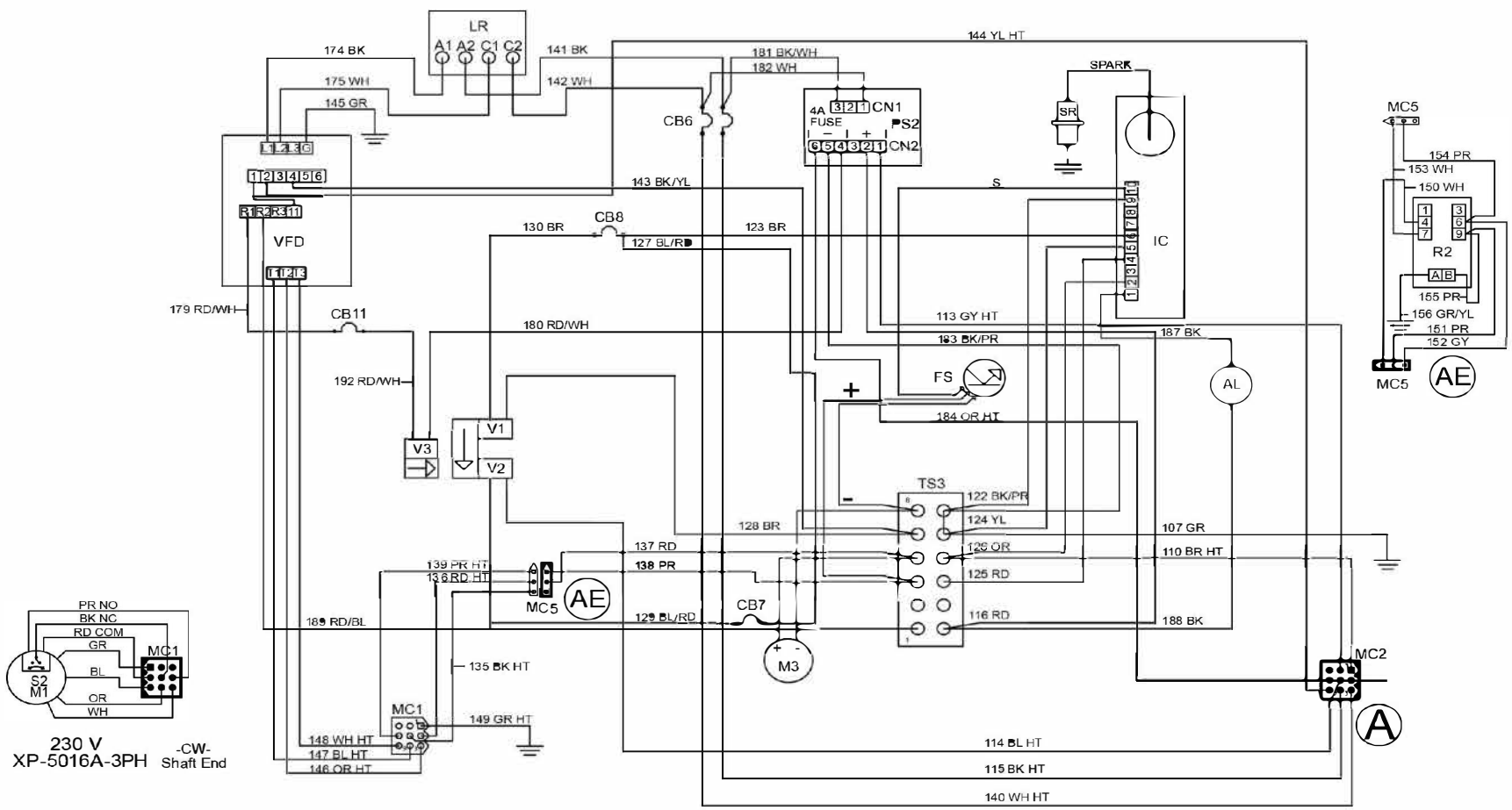

- |      |   |     |                            |     |                                |
|------|---|-----|----------------------------|-----|--------------------------------|
| AL   | Alarm, Ignition                             | LR  | Line Reactor, 3% Impedance | TS3 | Terminal Strip                 |
| CB6  | Circuit Breaker, 10 Amp, Main               | M1  | Motor, Oven Fan            | VFD | Oven Fan Motor Frequency Drive |
| CB7  | Circuit Breaker, 2 Amp, Gas Valve, HI/Low   | M3  | Motor, FPPG                | V1  | Gas Valve ON/OFF               |
| CB8  | Circuit Breaker, 2 Amp, Gas Valve, ON/OFF   | PS2 | Power Supply               | V2  | Gas Valve HI/LOW               |
| CB11 | Circuit Breaker, 2 Amp, Gas Valve, Shut-Off | R2  | Proving Relay              | V3  | Gas Valve ON/OFF, Shut-Off     |
| FS   | Flame Sense                                 | S2  | Switch, Centrifugal        |     |                                |
| IC   | Ignition Control                            | SR  | Spark Rod                  |     |                                |

RD-Red BK-Black BL-Blue BR-Brown GR-Green YL-Yellow PR-Purple HT-High Temp OR-Orange WH-White GY-Gray

X3F-3270-2B  
 X3F-3870-2B  
 230 VAC 1 PH 50 Hz  
 XD-9130F-GA-AE 2B  
 Left Side  
 02/27/2017

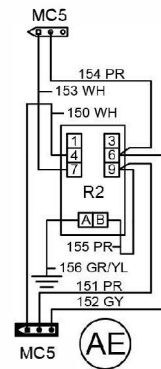
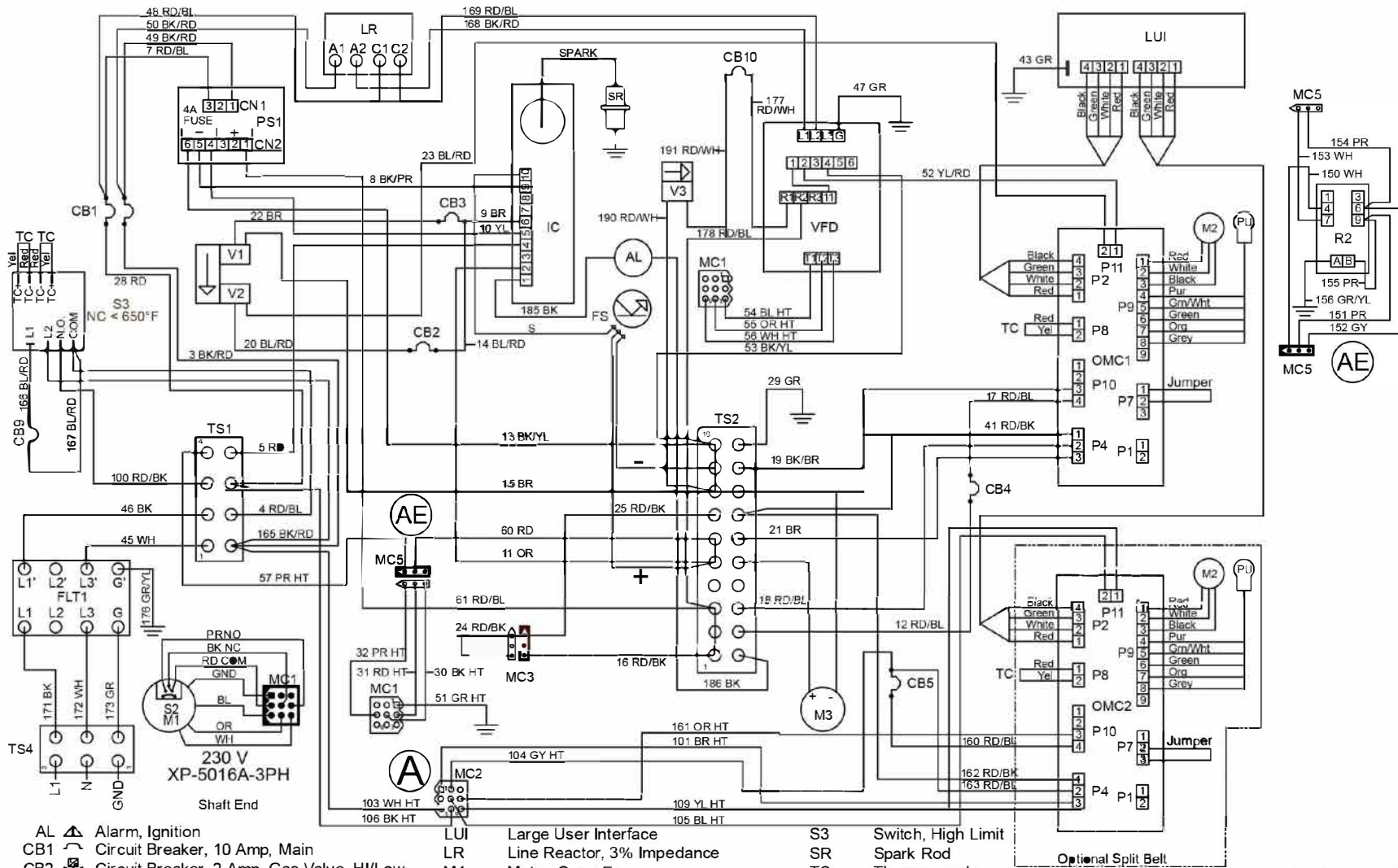

- |              |   |      |                                       |     |                                |
|--------------|---|------|---------------------------------------|-----|--------------------------------|
| AL           | Alarm, Ignition                             | LUI  | Large User Interface                  | S3  | Switch, High Limit             |
| CB1          | Circuit Breaker, 10 Amp, Main               | LR   | Line Reactor, 3% Impedance            | SR  | Spark Rod                      |
| CB2          | Circuit Breaker, 2 Amp, Gas Valve, HI/LOW   | M1   | Motor, Oven Fan                       | TC  | Thermocouple                   |
| CB3          | Circuit Breaker, 2 Amp, Gas Valve, ON/OFF   | M2   | Motor, Conveyor                       | TS1 | Terminal Strip                 |
| CB4          | Circuit Breaker, 1/2 Amp, Conveyor Motor    | M3   | Motor, FPPG                           | TS2 | Terminal Strip                 |
| CB5          | Circuit Breaker, 1/2 Amp, Conveyor Motor    | OMC1 | Oven Control, Main                    | TS4 | Terminal Strip                 |
| CB9          | Circuit Breaker, 1/2 Amp, High Limit        | OMC2 | Oven Control, Split Belt & 2nd Burner | VFD | Oven Fan Motor Frequency Drive |
| CB10         | Circuit Breaker, 2 Amp, Gas Valve, Shut-Off | PS1  | Power Supply                          | V1  | Gas Valve ON/OFF               |
| FLT1         | Power Filter, EMI                           | PU   | Pick-Up                               | V2  | Gas Valve HI/LOW               |
| FS           | Flame Sense                                 | R2   | Proving Relay                         | V3  | Gas Valve ON/OFF, Shut-Off     |
| IC           | Ignition Control                            | S2   | Switch, Centrifugal                   |     |                                |
| RD-Red       |   |      |                                       |     |                                |
| BK-Black     |   |      |                                       |     |                                |
| BL-Blue      |   |      |                                       |     |                                |
| BR-Brown     |   |      |                                       |     |                                |
| GR-Green     |   |      |                                       |     |                                |
| YL-Yellow    |   |      |                                       |     |                                |
| PR-Purple    |   |      |                                       |     |                                |
| HT-High Temp |   |      |                                       |     |                                |
| OR-Orange    |   |      |                                       |     |                                |
| WH-White     |   |      |                                       |     |                                |
| GY-Gray      |   |      |                                       |     |                                |

X3F-3270-2B  
X3F-3870-2B

230 VAC 1 PH 50 Hz  
XD-9130F-GA-AE 2B  
Right Side  
02/27/2017

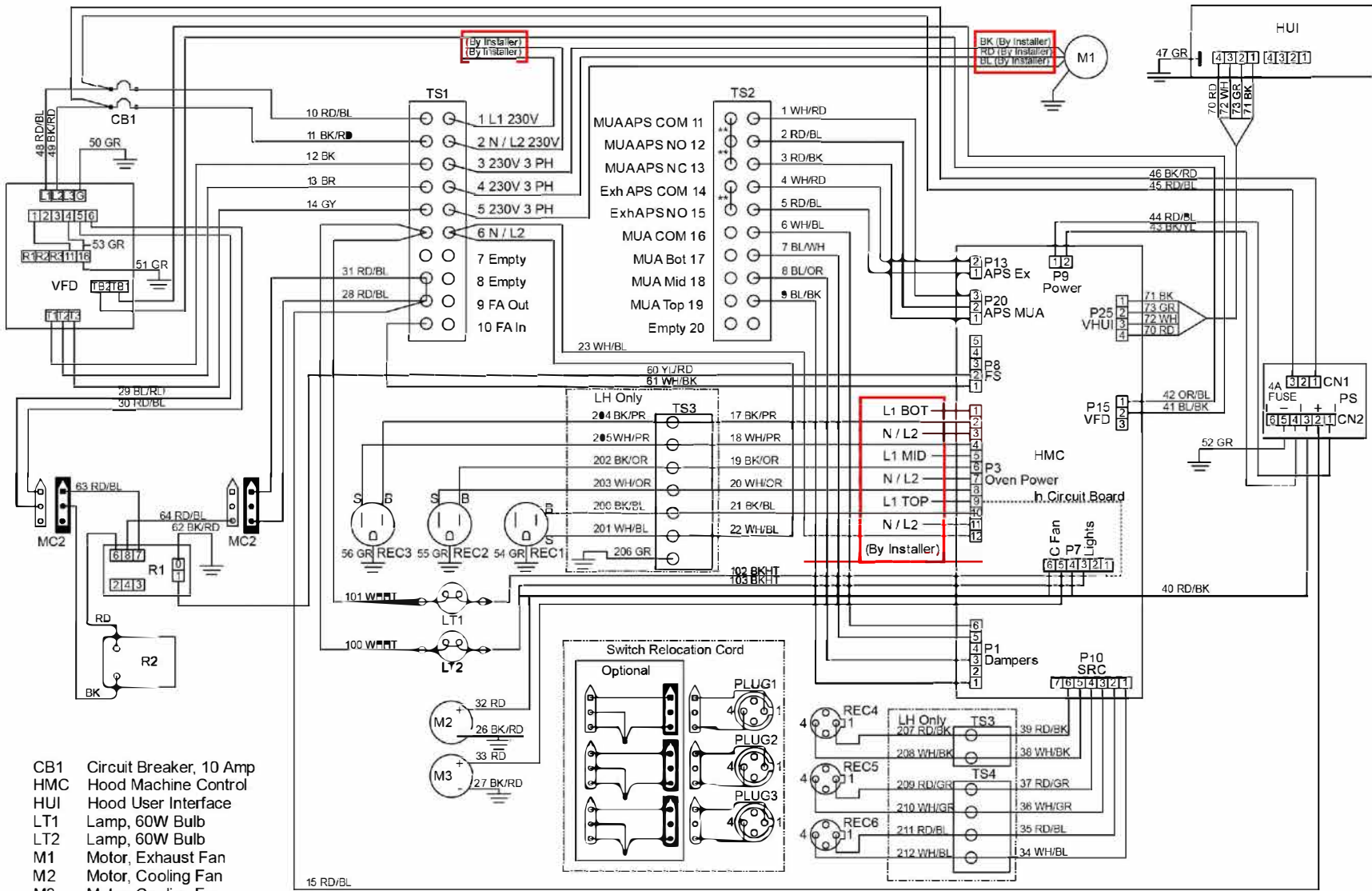

- CB1 Circuit Breaker, 10 Amp
- HMC Hood Machine Control
- HUI Hood User Interface
- LT1 Lamp, 60W Bulb
- LT2 Lamp, 60W Bulb
- M1 Motor, Exhaust Fan
- M2 Motor, Cooling Fan
- M3 Motor, Cooling Fan
- PS Power Supply
- R1 Fire Suppression Relay
- R2 Fire Suppression Time Delay Relay
- REC1 Receptacle, Power, Top Oven
- REC2 Receptacle, Power, Middle Oven
- REC3 Receptacle, Power, Bottom Oven
- REC4 Receptacle, Switch, Top Oven
- REC5 Receptacle, Switch, Middle Oven
- REC6 Receptacle, Switch, Bottom Oven
- SRC Switch Relocation Cord
- TS1 Terminal Strip
- TS2 Terminal Strip
- TS3 Terminal Strip
- TS4 Terminal Strip
- VFD Variable Frequency Drive

- REC3 Receptacle, Power, Bottom Oven
- REC4 Receptacle, Switch, Top Oven
- REC5 Receptacle, Switch, Middle Oven
- REC6 Receptacle, Switch, Bottom Oven
- SRC Switch Relocation Cord
- TS1 Terminal Strip
- TS2 Terminal Strip
- TS3 Terminal Strip
- TS4 Terminal Strip
- VFD Variable Frequency Drive

- TS1 Terminal Strip
- TS2 Terminal Strip
- TS3 Terminal Strip
- TS4 Terminal Strip
- VFD Variable Frequency Drive

HD-9130E-GAS-VFD-S

03/16/2017

RD-Red BK-Black BL-Blue BR-Brown GR-Green YL-Yellow PR-Purple HT-High Temp OR-Orange WH-White GY-Gray \*\* - Remove Jumpers for APS

Technical Support US: 888-443-2751



Technical Support INTL: 316-943-2751

Technical Support US: 888-443-2751



Technical Support INTL: 316-943-2751

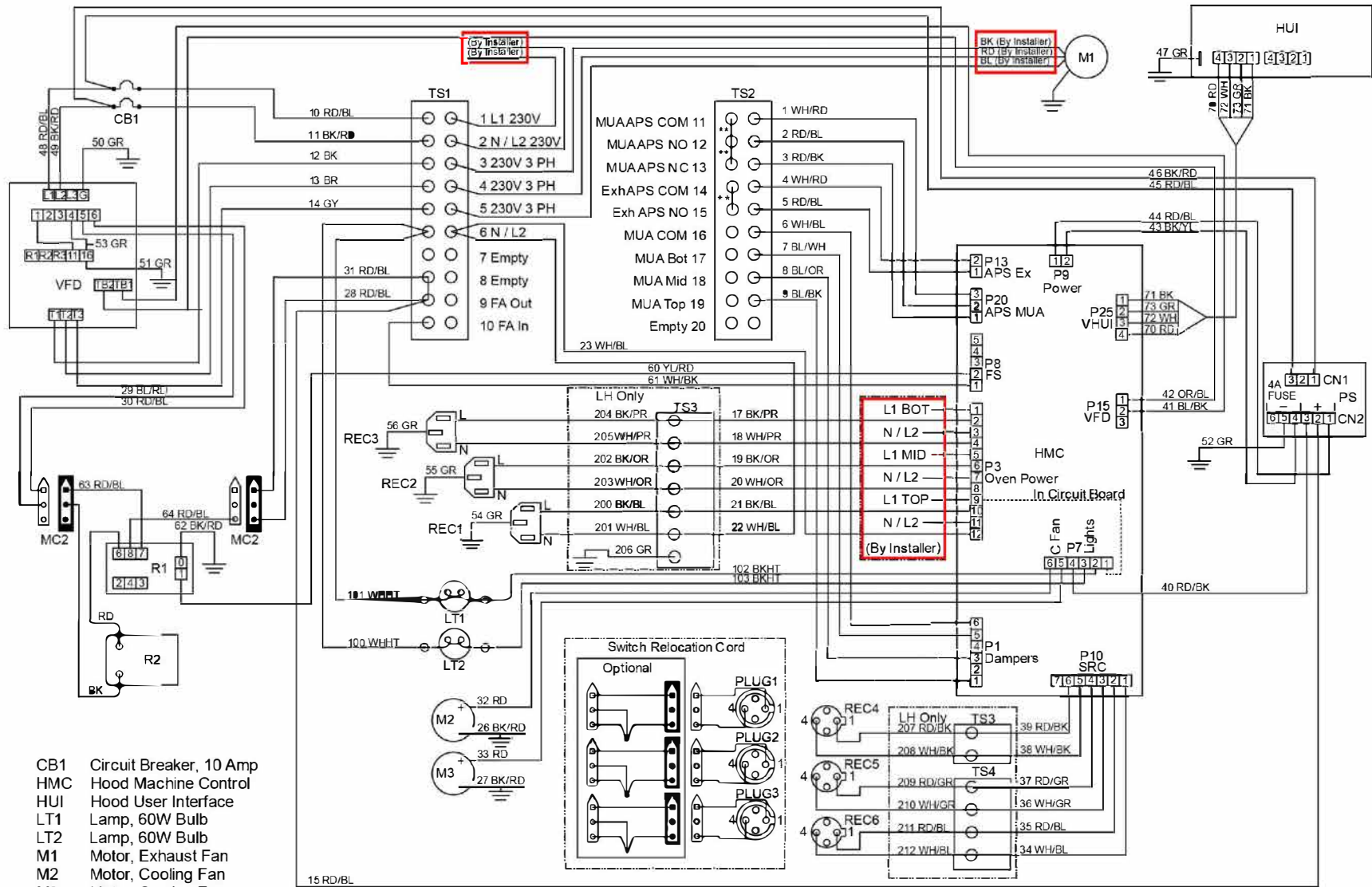

- CB1 Circuit Breaker, 10 Amp
- HMC Hood Machine Control
- HUI Hood User Interface
- LT1 Lamp, 60W Bulb
- LT2 Lamp, 60W Bulb
- M1 Motor, Exhaust Fan
- M2 Motor, Cooling Fan
- M3 Motor, Cooling Fan
- PS Power Supply
- R1 Fire Suppression Relay
- R2 Fire Suppression Time Delay Relay
- REC1 Receptacle, Power, Top Oven
- REC2 Receptacle, Power, Middle Oven
- REC3 Receptacle, Power, Bottom Oven
- REC4 Receptacle, Switch, Top Oven
- REC5 Receptacle, Switch, Middle Oven
- REC6 Receptacle, Switch, Bottom Oven
- SRC Switch Relocation Cord
- TS1 Terminal Strip
- TS2 Terminal Strip
- TS3 Terminal Strip
- TS4 Terminal Strip
- VFD Variable Frequency Drive

- REC3 Receptacle, Power, Bottom Oven
- REC4 Receptacle, Switch, Top Oven
- REC5 Receptacle, Switch, Middle Oven
- REC6 Receptacle, Switch, Bottom Oven
- SRC Switch Relocation Cord
- TS1 Terminal Strip
- TS2 Terminal Strip
- TS3 Terminal Strip
- TS4 Terminal Strip
- VFD Variable Frequency Drive

- TS1 Terminal Strip
- TS2 Terminal Strip
- TS3 Terminal Strip
- TS4 Terminal Strip
- VFD Variable Frequency Drive

RD-Red BK-Black BL-Blue BR-Brown GR-Green YL-Yellow PR-Purple HT-High Temp OR-Orange WH-White GY-Gray \*\* - Remove Jumpers for APS

HD-9130E-GAS-VFD-W

03/16/2017

HOOD SCHEMATIC - WORLD W/FS-W/VFD

75

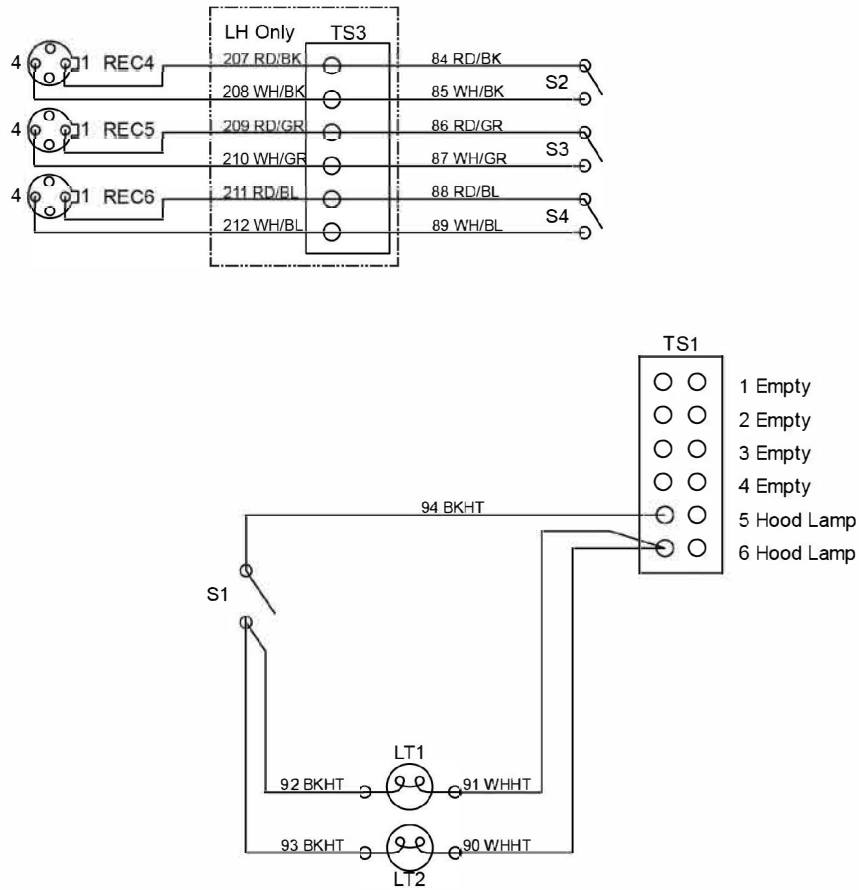

- LT1 Lamp, 60W Bulb
- LT2 Lamp, 60W Bulb
- REC4 Receptacle, Top Oven
- REC5 Receptacle, Middle Oven
- REC6 Receptacle, Bottom Oven
- S1 Switch, Light
- S2 Switch, Top Oven
- S3 Switch, Middle Oven
- S4 Switch, Bottom Oven
- TS1 Terminal Strip
- TS3 Terminal Strip

HD-9130E-NV

RD-Red BK-Black BL-Blue GR-Green HT-High Temp WH-White

03/16/2017



XLT Ovens  
PO Box 9090  
Wichita, Kansas 67277

US: 888-443-2751 FAX: 316-943-2769 INTL: 316-943-2751 WEB: [www.xltovens.com](http://www.xltovens.com)