



XD 9007C
SWFHE
11/01/2016

Simple. Smart.



XLT Electric Oven & AVI Hood Parts & Service Manual



Read This Manual Before Using This Appliance.

Current versions of this manual, Rough-In Specifications, Installation & Operation Manual, Architectural Drawings, & a list of International Authorized Distributors are available at: www.xltovens.com

For use with the following XLT Electric Oven Versions:

Standard (S) F
World (W) F

For use with the following AVI Electric Hood Versions:

Standard (S) E
World (W) E



XLT Ovens
PO Box 9090
Wichita, Kansas 67277

US: 888-443-2751 FAX: 316-943-2769 INTL: 316-943-2751 WEB: www.xltovens.com



SAFETY DEPENDS ON YOU



CAUTION

This appliance is for professional use by qualified personnel. This appliance must be installed by qualified persons in accordance with the regulations in force. This appliance must be installed with sufficient ventilation to prevent the occurrence of unacceptable concentrations of substances harmful to health in the room in which it is installed. This appliance needs an unobstructed flow of fresh air for satisfactory operation & must be installed in a suitably ventilated room in accordance with current regulations. This appliance should be serviced by qualified personnel at least every 12 months or sooner if heavy use is expected.



DANGER

Improper installation, adjustment, alteration, service or maintenance can cause property damage, injury, or death. Read the installation, operating and maintenance instructions thoroughly before installing, using, or servicing this equipment.



DANGER

FOR YOUR SAFETY

Do not store or use gasoline or other flammable liquids or vapors in the vicinity of this or any other appliance.









- Do not restrict the flow of ventilation air to the unit. Provide adequate clearance for operating, cleaning, and maintaining the unit when in the installed position.
- Keep the area free and clear of combustible material. DO NOT SPRAY AEROSOLS IN THE VICINITY OF THIS APPLIANCE WHILE IT IS IN OPERATION.
- Ovens are certified for installation on combustible floors.
- Electrical schematics are located inside the control box of the oven and in this manual. Disconnect input power to the unit before performing any maintenance.
- This unit requires a ventilation hood. The installation must conform to local codes.
- This unit must be operated by the same voltage, phase, & frequency of electrical power as designated on the nameplate label located on the side of the unit.
- Minimum clearances must be maintained from combustible & non-combustible construction materials.
- Follow all local codes when installing this unit.
- Follow all local codes to electrically ground the unit.
- Appliance is not to be cleaned with high pressure water.
- XLT ovens are certified for use in stacks of up to three (3) units of XLT products. Integration of other manufacturer's products into an oven stack is not recommended, & will void any warranties. XLT Ovens assumes no liability for mixed product applications.
- Failure to call XLT Customer Service at 1-888-443-2751 prior to contacting a repair company voids any & all warranties.
- PLEASE RETAIN THIS MANUAL FOR FUTURE REFERENCE.
- This appliance operates below 70 dBA.

XLT Ovens has spent millions of dollars designing and testing our products as well as developing Parts & Service Manuals. These manuals are the most complete and easiest to understand in the industry. However, they are worthless if they are not followed.

We have witnessed store operators and building owners lose many thousands of dollars in lost revenue due to incorrect installations. We highly recommend you follow all instructions given in this manual as well as follow best practices in plumbing, electrical, and HVAC building codes.

Definitions & Symbols

A safety instruction (message) includes a “Safety Alert Symbol” & a signal word or phrase such as **DANGER**, **WARNING** or **CAUTION**. Each signal word has the following meaning:

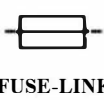
 DANGER	ISO 7000-0434: Indicates a potentially hazardous situation that, if not avoided, can result in serious injury or death.		
 HIGH VOLTAGE	IEC 60417-5036: This symbol indicates high voltage. It calls your attention to items or operations that could be dangerous to you & other persons operating this equipment. Read the message & follow the instructions carefully.		
 WARNING	ISO 7000-0434: Indicates a potentially hazardous situation, that if not avoided, can result in minor to moderate injury or serious damage to the product. The situation described in the CAUTION may, if not avoided, lead to serious results. Important safety measures are described in CAUTION (as well as WARNING), so be sure to observe them.		
 CAUTION	ISO 7000-0434: Indicates a potentially hazardous situation, that if not avoided, can result in minor to moderate injury or serious damage to the product. The situation described in the CAUTION may, if not avoided, lead to serious results. Important safety measures are described in CAUTION (as well as WARNING), so be sure to observe them.		
 READ MANUAL	ISO 7000-0790: Read the instructions before using this machine.	 CLASS II EQUIPMENT	IEC 60417-5172: A class II or double insulated electrical appliance.
 PROTECTIVE EARTH	IEC 60417-5019: Terminal which is intended for connection to an external conductor.	 EQUIPOTENTIALITY	IEC 60417-5021: Having the same electric potential or uniform electric potential.
 FUSE-LINK	IEC 60417-5016: Terminal which is intended for connection to an external conductor.		



Warranty - US and Canada

Rev G

Approval Date: 11/01/2016

XLT warrants Version F ovens manufactured after January 1, 2016 to be free from any defect in material and workmanship under normal use for seven (7) years from the date of original purchase by the end user, and further warrants main fan blades, conveyor shafts, and conveyor bearings for ten (10) years. XLT further warrants all ovens to be free from rust for ten (10) years from the date the equipment is originally purchased. XLT warrants Version E hoods manufactured after December 1, 2015 to be free from any defect in material and workmanship under normal use for five (5) years from the date of original purchase by the end user purchaser. In the event of a part failure, XLT will furnish a replacement part and pay for all labor associated with the replacement of the part. If upon inspection XLT determines that the part is not defective, all incurred cost will be the responsibility of the end user purchaser. This warranty is extended to the original end user purchaser and is not transferable without prior written consent of XLT. Damages are limited to the original purchase price.

DUTIES OF THE OWNER:

- The owner must inspect the equipment and crates at time of receipt. Damage during shipment is to be immediately reported to the carrier and also to XLT
- The equipment must be installed and operated in accordance with the written instructions furnished with the unit
- This warranty shall not excuse the owner from properly maintaining the equipment in accordance with the written instructions furnished with the unit
- A copy of the "Initial Start-Up Checklist" must be filled out and returned to XLT when the unit is initially installed, and/or when the unit is removed and installed in another location
- The gas, electric, and HVAC utilities must be connected to the oven and installed by locally licensed contractors
- Failure to contact XLT Ovens prior to contacting a repair company for warranty work voids any and all warranties

WHAT IS NOT COVERED:

- Freight damage
- Overtime charges
- Any part that becomes defective because of utility services (power surges, high or low voltages, high or low gas pressure or volume, contaminated fuel, or improper utility connections)
- Any part that becomes defective because of moisture and/or other contaminants
- Conveyor belts
- Filters
- Exhaust Fans
- Light Bulbs
- Painted or Powder Coated surfaces
- Normal maintenance or adjustments
- This warranty shall not apply if the equipment or any part is damaged as a result of accident, casualty, alteration, misuse, abuse, improper cleaning, improper installation, improper operation, natural disasters, or man-made disasters

CLAIMS HANDLED AS FOLLOWS:

Should any such defect be discovered, XLT must be notified. Upon notification, XLT will arrange for necessary repairs to be made by an authorized service agent. Denial of services upon the arrival of an authorized service agent will release XLT of any and all warranty obligations.





Warranty - International

Rev J

Approval Date: 11/01/2016

When purchased through an Authorized International Distributor, XLT warrants Version F Ovens and Version E Hoods to be free from any defect in material and workmanship under normal use. The Authorized International Distributor will repair XLT products during the warranty period. This warranty is extended to the original end user purchaser and is not transferable without prior written consent of the Authorized International Distributor. Damages are limited to the original purchase price. Products purchased by any other means other than an Authorized International Distributor will have no warranty. This warranty applies to areas outside the 50 United States of America and Canada.

DUTIES OF THE OWNER:

- The owner must inspect the equipment and crates at time of receipt. Damage during shipment is to be immediately reported to the carrier and also to the Authorized International Distributor.
- The equipment must be operated in accordance with the written instructions furnished with the unit.
- This warranty is not valid unless equipment is installed, started, and demonstrated under the supervision of the Authorized International Distributor.
- This warranty shall not excuse the owner from properly maintaining the equipment in accordance with the written instructions furnished with the unit.
- A copy of the "Initial Start-Up Checklist" must be filled out and returned to the Authorized International Distributor when the unit is initially installed, and/or when the unit is removed and installed in another location.
- The gas, electric, and HVAC utilities must be connected to the equipment and installed by locally licensed contractors.
- The Authorized International Distributor must be contacted for service. Failure to contact the Authorized International Distributor prior to contacting a repair company for warranty work voids any and all warranties.

WHAT IS COVERED (Subject to local market conditions):

- 5 year labor – Extensions may be available and charges may apply
- 5 year parts – Extensions may be available and charges may apply
- 5 years parts and labor on: oven fan blade, structural welds, conveyor shafts, conveyor bearings, rusted materials in ovens

WHAT IS NOT COVERED (Subject to local market conditions):

- Freight damage
- Any part that becomes defective because of utility services (power surges, high or low voltages, high or low gas pressure or volume, contaminated fuel, or improper utility connections)
- Any part that becomes defective because of moisture and/or other contaminants
- Conveyor belts
- Filters
- Exhaust fans
- Light bulbs
- Painted or Powder Coated surfaces
- Rusted materials in hoods
- Normal maintenance or adjustments
- This warranty shall not apply if the equipment or any part is damaged as a result of accident, casualty, alteration, misuse, abuse, improper cleaning, use of caustic/acidic chemicals, improper installation, improper operation, natural disasters, or man-made disasters

CLAIMS HANDLED AS FOLLOWS:

Should any such defect be discovered, the Authorized International Distributor must be notified. Upon notification, the Authorized International Distributor will arrange for necessary repairs.

7781 W Kellogg Drive 67209-2003 - PO Box 8080 67277-0080 - Wichita, Kansas
Voice (316) 843-2751 - (888) 443-2751 - Fax (316) 843-2789
www.xltovens.com



This page intentionally left blank.

Responsibility	XLT/Service Company	Owner/ Contractor
Site Survey: Verify electric and gas meter/regulator sizes	X	
Supply wiring from TS1 #R3, R4, R5 to exhaust fan		X
Supply (1) single phase 230 volt 10 amp circuit from breaker panel to XLT Hood		X
Installation of new hood per XLT Installation & Operation Manual		X
Suspend XLT Hood from ceiling		X
Weld ducting to XLT Hood		X
Install new exhaust fan on roof		X
Supply power to XLT Hood		X
Install Duct Cover or Valance above XLT Hood		X
Installation of new ovens per XLT Installation & Operation Manual		
Stands assembled and set in place	X	
Ovens moved and stacked with proper lifting equipment	X	
Assemble shrouds & brackets to XLT Oven/Hood	X	
Hook-up fuel to XLT products		
Install piping and drip legs		X
Check for leaks		X
Install flexible gas hoses	X	
Connect electrical supply	X	
Hook-ups may require Permit and Code Inspections		X
Relocate Make-Up-Air to enter the room at the ends of the ovens		X
Start-up per XLT Installation & Operation Manual:	X	
Gas pressure/leak testing, hood/oven functions, adjust as necessary	X	
Start-Up Checklist must be submitted to XLT to validate Warranty		X

This manual, which contains an illustrated parts breakdown, has been prepared as an aid in understanding how the unit operates, how to diagnose problems, and order parts for the equipment. All of the parts, listed in the parts breakdown, are manufactured with the same precision as the original equipment.

XLT parts and service providers are available worldwide. There are authorized service providers located in the principle cities of the United States. There are also authorized Distributors located throughout the world.

The Theory of Operation section describes how the unit operates. An understanding of normal operation will greatly aid diagnosis and troubleshooting. The Troubleshooting section asks simple yes or no questions. The next question or statement entirely depends upon the previous answer. It will lead to the solution of a problem in the most efficient way. The illustrated parts section identifies the various sub-assemblies and detailed parts which make up the equipment, as well as the part number. An explanation of how to order parts is included.

This manual is designed to supplement the Installation & Operation Manual provided with the unit when new. Please refer to it for descriptions, dimensions, weights, electrical requirements, maintenance schedules, and certifications.

XLT Ovens wants you to be totally satisfied with every aspect of owning & using your oven & hood. Your feedback, both positive & negative, is very important to us as it helps us understand how to improve our products & our company. Our goal is to provide you with equipment that we can be proud to build & you can be proud to own.

To receive technical support for the oven or hood you purchased, XLT has qualified customer service personnel that can provide assistance on any type of XLT oven or hood equipment problem you may experience. Customer Service is available 24/7/365 at 888-443-2751 or visit www.xltovens.com.



DANGER

Repairs of all appliances & ventilation exhaust hoods should only be performed by a qualified professional who has read & understands these instructions & is familiar with proper safety precautions. Read this manual thoroughly before installing or servicing this equipment.



NOTE

Notes indicates an area or subject of special merit, emphasizing either the product's capability or common errors in operation or maintenance.



TIP

Tips give a special instruction that can save time or provide other benefits while installing or using the product. The tip calls attention to an idea that may not be obvious to first-time users of the product.

Warning & Safety Information..... 2

Warranty..... 4

Installation Responsibilities..... 7

General 8

Oven Theory of Operation 10

Hood Theory of Operation 16

Oven Troubleshooting..... 19

Hood Troubleshooting..... 20

Oven Service Procedures..... 22

Hood Service Procedures 24

Oven Parts 27

Hood Parts..... 49

Oven Schematics 52

Hood Schematics..... 58

Notes..... 61

For maintenance procedures, please refer to the XLT Installation & Operation Manual.

Save this Manual

This document is the property of the owner of this equipment.

XLT Ovens reserves the right to make changes in design & specifications, and/or make additions to or improvements to its product without imposing any obligations upon itself to install them in products previously manufactured.

All Right Hand & Left Hand designations in this manual are from the point of view as if standing directly in front of the glass sandwich door.

Revision History Table		
Revision	Comments	Date
B	Updated Oven Theory of Operation Pg 8-12, Updated Control Boxes Pg. 36-46, and Updated Oven Schematics on Pg. 50-55	05/12/2016
C	Updated US and International Warranties On Pg. 4 and 5, Added Installation Responsibilities to Pg. 7, Updated Oven and Hood Theory of Operation Pg. 10-18, Updated World Control Box Assembly Pg. 44-48, Updated Hood Control Box Pg. 50-51, Updated Oven and Hood Schematics and Updated Images To Reflect Decals Moving	11/01/2016

When the main power on the Large User Interface (LUI) is turned on:

1. The Oven Fan Motor (M1) located in the Back Wall will run.
2. The Fan (M3) located on the Control Panel will run.
3. The LUI will display actual temperature until set point is reached.
4. The LUI will display belt time.
5. The conveyor belt will move.

The first part of the Theory of Operation explains how electrical power is delivered to the oven and initial sequences when the main power on the LUI is turned on. The remainder of the Theory of Operation section explains the function of components in alphabetical order. These components are also listed on the schematic.

- Line voltage for Standard Ovens is assumed to be 208/240 VAC, 3 Φ , 60 Hz.
- Line voltage for World Ovens is assumed to be 380 VAC, 3 Φ , 50 Hz.

Power originates at the electrical connection on the wall. Line voltage is then carried into the oven through the power cord to the Power Block (PB). 3 wires come off the power block. One wire goes to the Circuit Breaker (CB) and then continues on to the Power Supply (PS). The other leg acts as a neutral for the PS and The Main Motor (M1). After the PS, 24 VDC is delivered to the Terminal Strip (TS2). From the other side of the TS2, power is then supplied to the Oven Machine Control (OMC).

When the main power button is turned on, line voltage will be carried through the Main OMC the TS2 #6L after a 30 second delay.

- The OMC sends power to the Oven Fan Motor Relay (R1) or the Oven Fan Motor Frequency Drive (VFD World and Australia Only). Which then delivers power to the Oven Fan Motor (M1). Once the Main Motor Centrifugal Switch (S2) closes it provides power to the coil of the Contactors (C1 and C2), which opens the contactor sending power to the SSRs (SSR1-4) and Heating Elements (H1-H6). The SSRs are elements controlled by the OMC.

C1 & C2 - A contactor is an electrically controlled switch used for switching a power circuit. A contactor is controlled by a control circuit that has a much lower power level than the switched circuit. They consist of a small coil and a set of three SPST contacts. When the LUI is turned on and the S2 is closed, 24 VDC voltage is applied to the coil, which closes the contacts. Then power is allowed to flow to the SSR's. If the temperature at S3 exceeds 600° F, or if M1 does not rotate, then voltage is interrupted to the coil, and will open the contactors.

CAP - The Capacitor is physically mounted inside the Control Box but wired to the externally mounted M1. The M1 is a Permanent Split Capacitor (PSC) motor. PSC means a capacitor motor in which the starting capacitor and the auxiliary winding remain in the circuit for both starting and running. The CAP is a 30.0 uF +/- 6% 370VAC/B 50/60 Hz.

CB - Circuit Breakers are used to protect electrical components. The current value is printed on the front of all breakers. If a CB is tripped, eliminate the cause and press the front to reset.

FLT 1 - Is an inline filter used in world ovens. The filter is placed in series with the Line voltage being supplied to the oven. The filter is used to reduce Electromagnetic Interference created by our equipment and back-feeding it into other appliances. EMI filters use capacitors to inhibit direct current while permitting alternating current. EMI filters also use inductors which redirect high voltages and high frequencies by dissipating them to ground.

H1-H6 - The Heating Elements convert electricity into heat through the process of joule heating. Electric current through the element encounters resistance, resulting in heating the element. The resistance values of the four (4) different part numbers used are:

- XP-5201-208-4.5 4500 Watt 9.61 Ohms
- XP-5201-240-4.5 4500 Watt 12.80 Ohms
- XP-5202-208-5.3 5300 Watt 8.16 Ohms
- XP-5202-240-5.3 5300 Watt 10.87 Ohms

Please refer to the Parts section for the proper application.

LR– The Line Reactor is used in all world ovens. It is an inductor wire between the incoming AC power source and the VFD. It is used to filter out spikes of current and reduce harmonics.



- 1) P1- Not Used
- 2) P2- RS-485 Cable To OMC1
 - 1) +5V
 - 2) 485-
 - 3) 485+
 - 4) Ground
- 3) P3- RS-485 Cable To OMC2
 - 1) +5V
 - 2) 485-
 - 3) 485+
 - 4) Ground
- 4) P5- Ground
- 5) P17- Not Used



LUI - The Large User Interface is powered by the OMC by the RS 485 cable. The main power button is located on the front face of the LUI. The conveyor(s) and temperature of the oven is controlled through the LUI. You can change the factory settings for the oven size, VFD/No VFD, cool down mode, and Gas/Electric, etc. For a Standard Oven it will also display the main fan amps. The LUI will display error messages and maintenance alarms. There are 12 menu presets for predetermined time and temperature settings. The screen can be locked to prevent unwanted mischief.

M1 – The Main Motor for standard ovens is a PSC, single phase, capacitor run motor and has an internal S2. The motor is dual voltage and reversible. The voltage to power the motor comes from the R1 terminal #2. For world ovens M1 is a 3 phase inverter rated motor with an internal S2. It gets power from a variable frequency drive which is then turned on by the OMC. The main motor will continue to operate for approximately 30 minutes or until the oven temperature is less than 225 degrees Fahrenheit after the oven is turned off. There are no user serviceable parts in the motor, and the bearings are permanently lubricated.

M2 - The Conveyor Motor is a brushless 24 VDC gear motor. The motor receives current from the OMC through three (3) wires; 1) A black or “W” phase, 2) a white or “V” phase, and 3) a red or “U” phase. They carry between 18 to 24 VDC. Each wire is energized by the OMC in sequence to provide power to the individual stator coils which, in turn, provide motor rotation. To determine the rotor position and send this position to the controller, three (3) Hall Effect switches are utilized. They read the rotational information from a disc mounted on the rotor assembly. This information is transmitted to the OMC by three (3) wires; 1) an orange “U” phase pole signal output, 2) a green “V” phase pole signal output, and 3) a green/white “W” phase pole signal output. These are located in a plug that inserts into the OMC1 or OMC2. There are two (2) additional wires in this plug; 1) a purple wire which is supply voltage for the pole sensor, and 2) a gray wire that is ground. The OMC, using an internal logic circuit, energizes the stator coils to provide proper rotation and sets the energization (phase) timing to obtain the desired belt speed set on the controller. The motor drives an integral gear box that reduces the motor output speed to give the correct travel time to the conveyor belt. The integral gear box is sealed and permanently lubricated with grease. The ratio is 1/200. This motor contains no serviceable parts. The OMC will detect if the conveyor belt has a jam by monitoring the rotor signal. If the signal falls more than 25% below the expected rate a jam is detected. This action will stop the conveyor and display an alarm on the LUI. To reset the alarm press and hold “Time” key for 10 seconds.

M3 - The Flow Path Pressure Generating fan supplies combustion air for the Burner. It is controlled by turning on and off the main power button. A filter is provided to ensure clean air.

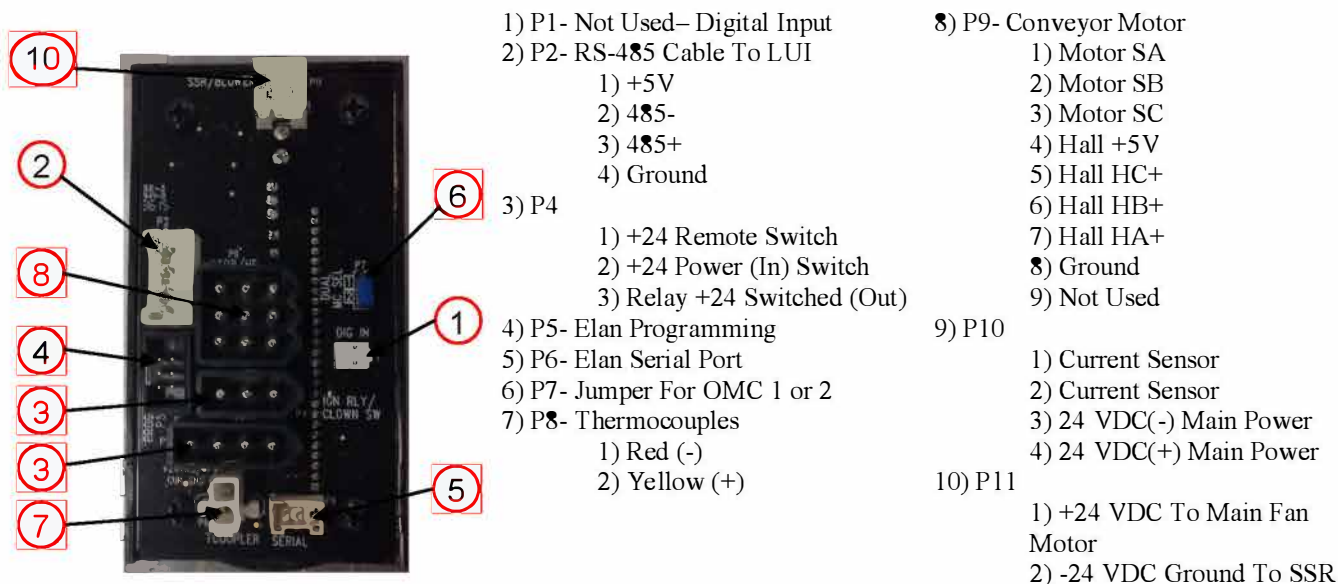

1) P1- Not Used-Digital Input

2) P2- RS-485 Cable To LUI

1) +5V

2) 485-

3) 485+

4) Ground

3) P4

1) +24 Remote Switch

2) +24 Power (In) Switch

3) Relay +24 Switched (Out)

4) P5- Elan Programming

5) P6- Elan Serial Port

6) P7- Jumper For OMC 1 or 2

7) P8- Thermocouples

1) Red (-)

2) Yellow (+)

8) P9- Conveyor Motor

1) Motor SA

2) Motor SB

3) Motor SC

4) Hall +5V

5) Hall HC+

6) Hall HB+

7) Hall HA+

8) Ground

9) Not Used

9) P10

1) Current Sensor

2) Current Sensor

3) 24 VDC(-) Main Power

4) 24 VDC(+) Main Power

10) P11

1) +24 VDC To Main Fan

Motor

2) -24 VDC Ground To SSR

OMC - The Oven Machine Control reads selections or parameters from the LUI. It holds the logic for the conveyor controls and the temperature controls. The OMC will turn on or off SSR's, start and stop M1, send the call for heat signal, reads the thermocouple and monitor the current sensor.

PB - The Power Block is a connection point for multiple wires of different gauges.



- 1) CN2- 24 VDC
 - 1) +24 VDC Main Power To OMC
 - 2) +24 VDC
 - 3) +24 VDC
 - 4) -24 VDC
 - 5) -24 VDC
 - 6) -24 VDC Ground To TS2
- 2) CN1- Line Voltage
 - 1) Neutral
 - 2) Not Used
 - 3) Line Voltage

PS - The Power Supply rectifies line voltage to 24 VDC, and supplies power to the OMC and S2. A 4 amp fuse is used to provide over current protection, which is mounted on the PS itself. There are no other fuses used anywhere else.

PU - The Pick-Up is physically mounted within M2 and utilizes hall effect technology integral to the M2 to monitor the rotation speed. The hall effect signal is transmitted to the OMC, which converts it into linear travel speed of the conveyor.

R1 - The Oven Fan Motor Relay is used as a remote switch to handle the higher amp load of M1.

S2 - The Centrifugal Switch is a SPDT switch physically mounted inside M1. When M1 comes up to full speed, S2 closes and sends a 24 VDC signal to the contactors. It functions as a safety feature to prevent burner operation if the M1 fails to rotate.

S3 - Standard Ovens- The High Limit Switch for standard ovens is a bi-metal, NC, SPST switch physically mounted in the side panel of the Bake Chamber. Its purpose is to provide fail safe operation. If the temperature of S3 exceeds 600°F, it opens and interrupts line voltage to all components when the switch opens.



- 1) Thermocouple 1 (+) - Yellow
- 2) Thermocouple 1 (-) - Red
- 3) Thermocouple 2 (-) - Red
- 4) Thermocouple 2 (+) - Yellow
- 5) COM- Line Voltage
- 6) N.O.- Switched Line Voltage
- 7) L2- High Limit Power
- 8) L1- High Limit Power

S3 - World Ovens- The High Limit Switch for world ovens is an electronic, SPST switch physically mounted on the side panel of the Bake Chamber. Its purpose is to provide fail safe operation. If the actual oven temperature exceeds 650°F the yellow LED will not illuminate. A red LED will flash and S3 opens to interrupts line voltage to all components. There are two (2) thermocouple inputs to this device. If the delta exceeds 20° C between the thermocouples, a yellow LED and Red will alternate flashing and S3 closes.

SSR 1-4 - A Solid State Relay is an electronic switching device in which a small control signal from the OMC a larger load current and voltage. It comprises a voltage sensor which responds to the TC, a solid state switching device which switches power to the Heating Elements (H1-6) either on or off, and does this without mechanical parts.

T/C - The thermocouple is a type K. It consists of two different conductors that produce a voltage proportional to a temperature difference between either end of the pair of conductors. The T/C is connected to P8 Terminals 1 & 2 on the OMC. The millivolt signal is used to display the actual temperature.

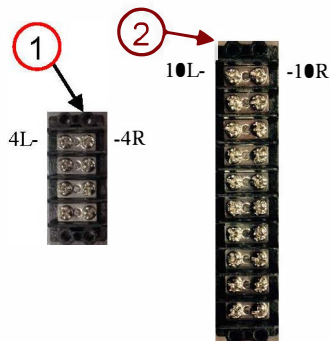

- 1) TS1- Terminal Strip
 1L) Neutral In
 2L) L1 In
 3L) Not Used
 4L) S2 Signal Out
 1R) Neutral Out
 2R) L1 Out
 3R) Not Used
 4R) S2 Signal In

- 2) TS2- Terminal Strip
 1L) Power SRC
 2L) Not Used
 3L) +24 VDC In
 4L) Not Used
 5L) Power M3(+)
 6L) Power S2 24 VDC
 7L) SRC
 8L) -24 VDC
 9L) COM To VFD
 10L) Ground To VFD
 1R) Not Used
 2R) Power 2nd OMC
 3R) 24 VDC Power To OCM1
 4R) Not Used
 5R) Power M3 (+)
 6R) Power To Relay COM
 7R) Cooldown Switch
 8R) M3 (-)
 9R) -24 VDC
 10R) Ground

TS 1 & 2- These are terminal strips, that serve as a connection point for wires.

VFD -The Variable Frequency Drive converts 50 Hz power into 60 Hz power so the ovens fan can run at the proper RPM's. The VFD converts the AC supply voltage to DC and then converts the DC to a suitable three-phase frequency source for M1. The VFD is turned on via the OMC P11 terminal #1. A complete manual can be found at www.xltovens.com.



- 1) Incoming Power
 1) Neutral
 2) Line Voltage
 3) Not Used
 4) Ground
 2) Not Used-VFD Relay
 3) Digital Inputs
 1) Stop Function
 2) Start / Run
 3) Not Used
 4) COM To TS2
 5) Not Used
 6) Not Used
 4) Exhaust Fan Power
 1) Power To Motor
 2) Power To Motor
 3) Power To Motor
 4) Not Used
 5) Not Used
 5) ModBus Comm

This page intentionally left blank.

When any one of the three oven switches on the Hood User Interface (HUI) are touched (capacitive touch);

1. The Exhaust Fan Motor (M1) located on the roof will run.
2. The ovens associated with the corresponding switches will turn on.

The first part of the Theory of Operation explains how electrical power is delivered to the hood and initial sequences when the HUI switch is turned on. The remainder of the Theory of Operation section explains the function of components in alphabetical order. These components are also listed on the schematic.

Power for the hood originates at the building's electrical service panel. Two (2) circuit are required, one is a single phase high voltage circuit for VFD/Fan circuit that connects to TS 1 terminals 1 & 2. The other circuit is a low voltage circuit for the lights. The line connects to P3 terminal 9 on HMC and the neutral connects to TS 1 terminal 5.

HUI mounted on the hood controls lighting, VFD activation, Make Up Air (MUA) activation and oven function. When HUI Light Switch is touched a relay is closed and voltage will go to lights. When ovens are installed with a hood, the Switch Relocation Cord (SRC) effectively eliminates the main switch located on the oven and transfers control to HUI switches on the hood. When HUI switches are touched a communication signal is sent to the VFD via ModBus signaling it to turn on to a set frequency, at the same time when HUI2 is activated a relay will allow line voltage to be carried through the Switch Relocation Cord (SRC) to the oven activating it. When HUI2-4 are activated the MUA will turn on. The VFD has a built in power supply that is wired to terminal 01 this puts the VFD in run mode so whenever a power loss is sensed the VFD will start back up in run mode once power is restored. The NO switch in the fire alarm system in the building needs to be connected to TS 1 terminals 9 & 10. When the alarm is activated 24 VDC from TS1 9 will return from the fire alarm system to TS1 10 then to HMC P8 to turn off lights, cooling fans, HUI, MUA, and making both relays R1 & R2 switch from NC to NO, causing the VFD to run at 60 Hz.

CB - Circuit Breakers are used to protect electrical components. If a CB is tripped, eliminate the cause and press the front to reset.

HUI – Hood User Interface contains the factory settings so that the hood will operate with the correct hertz when the correct oven size and number of ovens are selected. The factory settings also contain a selection for a VFD, Non VFD, type of MUA activation, and for a World installation. A beeping sound and the display will flash if an alarm occurs. An error message will display at top of screen on HUI. Touching the “I” button will give a brief description of how to correct the error (see Figure 1). Touching the “Light Bulb” button will turn the light on and off inside the hood. Touching the “Silver Square” buttons will turn each oven on or off and sequence the operation of the VFD and the MUA circuits. RS485 cable supplies power and communication between the HUI and HMC.

HMC – The Hood Machine Control is a printed circuit board that has all the relays to control these functions; oven activation SRC, MUA activation, VFD activation, monitors the air proving switches, and lighting activation. The HMC receives a continuous 24 VDC power source provided the CB1 breaker is on. This component also has independent relays to control oven power for fire suppression. If a signal from the fire system is received the oven(s) and lighting power is discontinued and the VFD will run at full speed. For a World installation, sail switch monitoring is available just by answering some questions through factory mode programming. The HMC will also program the PowerFlex 4M VFD each time the CB1 breaker is turned on. ModBus communication is used to change the frequency the VFD runs at depending on the number of ovens used. Error messages will appear on the screen to help with troubleshooting. The screen will flash and beep indicating a error has occurred, the alarm button can cancel this for 2 hours. If error has not been fixed beeping will return. The HMC has filter cleaning reminders available.

LT1 & LT2 - These are light bulbs at each end of the hood, and should illuminate when the HUI light button is touched, touch it again and the light turns off.

M1 – The Exhaust Fan Motor is a 3-phase, direct drive motor. In normal operation, it is powered by the VFD and its RPM will vary as the frequency from the VFD varies. There are no user serviceable parts in the motor, and the bearings are permanently lubricated.

M2 & M3 – The Cooling Fan Motor is a 24 VDC, direct drive motor. In normal operation, it is powered through HMC. These fans are used to keep the control box for the hood cool. There are no user serviceable parts in the motor, and the bearings are permanently lubricated.

PLUG 1, 2, & 3 – These are circular electrical plugs on one end of the Switch Relocation Cord (SRC). The plugs connect to Receptacles 4, 5, & 6 on the back of the hood. The other end of the SRC plugs into the oven wire harness, and eliminates the operator switch supplied in the oven. Conversely, when the HUI on the hood is turned off, the corresponding oven is turned off as well.

PS –The Power Supply rectifies line voltage to 24 VDC, and supplies power to the HMC, cooling fans, and fire suppression

R1 – Is a SPDT relay, which is an electrically operated switch. It uses an electromagnet to operate a switching mechanism. Voltage is supplied from TS1-9 to Ansul agent box. Once the fire alarm is activated voltage returns to TS1-10 over to HMC P8. That same voltage continues to R1-1 activating the coil in the relay, causing the contacts in the relay to switch from NC to NO. This will switch 24 VDC from terminal 6 to terminal 5 on the VFD causing the M1 to operate at 60 Hz.

R2 – Is a SPDT time delay relay, which is an electrically operated switch. It uses an electromagnet to operate a switching mechanism. Voltage continues from R1-6 to R2 via the red wire activating the coil in the relay, causing the contacts in the relay to switch from NC to NO after one second has expired. This action delays the application of the voltage on terminal (5) on the VFD.

REC 4, 5, & 6– These are circular electrical receptacles mounted on the back of the hood. The

Switch Relocation Cord (SRC) connects into these. This deactivates the main oven switch located on the oven and relocates the operation of it to the HUI. This capacitive touch (NO) switch is located on the front of the hood and controls the lights.

TS 1 & 2- These are terminal strips, that serve as a connection point for wires.

VFD - The Variable Frequency Drive (VFD) converts the AC supply voltage to DC and then converts the DC to a suitable three-phase frequency source for M1. Incoming power connects to terminals L1 & L2. M1 connects to terminals T1, T2, & T3 through TS1. The HMC sends the command to the ModBus to set the frequency for the combination of ovens selected. The VFD can receive a signal from the fire suppression system to command the drive to run at 60 Hz. A complete manual can be found at www.xltovens.com.

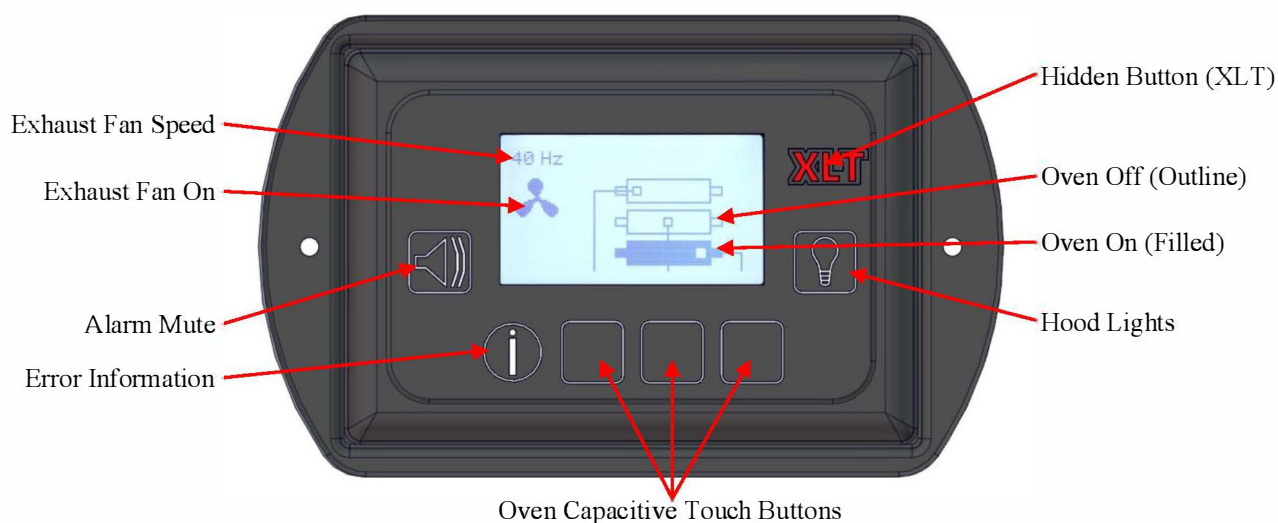

Figure 1

Mechanical Function

If your oven does not function properly, please verify the following conditions:

1. Verify that the power cord to the oven is connected and/or plugged in if equipped with a plug and receptacle.
2. Check to see that the circuit breakers in the building electrical service panel have not been tripped or turned off.
3. Check all circuit breakers on the oven control panel to ensure they have not been tripped.
4. Ensure proper voltage, amperage, and wire size.

If your oven still does not function properly, XLT has qualified customer service personnel that can provide assistance on any type of XLT oven problem you may experience. Customer Service is available 24/7/365 at 888-443-2751, or visit www.xltovens.com.



**HIGH
VOLTAGE**

Removing the hood VFD cover panel exposes high voltage. Proceed with caution and read the following the instructions carefully.

Initial troubleshooting of the hood:

1. Remove panel covering VFD to check and see if the circuit breaker is tripped.
2. Check the actual frequency of the VFD controller. To access the actual frequency, press <ESC> button until the Display Mode shows D001.
3. Check to see that the breaker in the service panel is not tripped.
4. Make sure the Switch Relocation Cords (SRC) are properly installed to the oven(s).
5. Check to see that the grease filters are clean & installed properly.
6. Check to see if the exhaust fan is rotating in the correct rotation. To verify fan rotation, remove the lid on the exhaust fan. Visually inspect rotation in accordance with label on fan housing.

Hood Machine Control LED Lights:

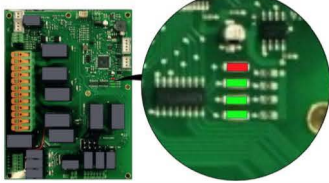

1. When the Red LED is lit it indicates an MC error.
2. When the first Green LED is lit it indicates power to MC.
3. When the second Green LED is lit it indicates that the exhaust fan on.
4. When the third Green LED is lit it indicates the MC communication to the VFD.

The VFD has internal diagnostics, and may show the following ERROR codes:

- F004 DC bus voltage fell below min value.
- F005 DC bus voltage fell below max value.
- F007 Motor Overload.
- F008 Heat sink Over Temp.
- F013 Ground Fault.
- F081 Comm Loss- RS485 port stopped communicating.

If any of the above error codes are displayed, then follow these steps to clear them.

1. Record error code on HUI.
2. Take the cover off the hood.
3. Cycle power with circuit breaker

If the corrective actions listed above do not correct the problem, then XLT has qualified customer service personnel that can provide assistance on any type of XLT Oven or AVI Hood problem you may experience. Customer Service is available at 888-443-2751 24/7/365, or visit www.xltovens.com.

For repairs or maintenance of the fire suppression system and components, contact the local Ansul dealer or XLT for assistance.

This page intentionally left blank.

Large User Interface Programming Procedure



Read the entire instruction before programming.

TIP

Configuration Key Functions

ENTER = Used to select and save parameters.

HIDDEN = Behind the XLT is a hidden button. This is used along with the up and down button to access the programming mode.

UP = Increases the setting of the selected parameter.

DOWN = Decrease the setting of the selected parameter.

To enter factory tech mode press both UP and DOWN button simultaneously for 10 seconds and the following parameters will be displayed:

1. Software Version
2. Serial Number Entry
3. Elapsed Time:
 - Total Hours.
 - Hours Since Filter has been Cleaned.
4. Belt Length: 32 = 1832 40 = 2440 or 3240 55 = 3255 or 3855 70 = 3270 or 3870
5. Belt Width: 18 = 1832 24 = 2440 32 = 3240, 3255, or 3270 38 = 3855 or 3870
6. Main Fan Type:
 - Defaults to On/Off.
7. Split Belt:
 - Defaults to No.
8. Dual Burner:
 - Available on oven sizes 3270 and 3870.
9. Fuel Type:
 - Gas Oven or Electric Oven.
10. Remote Hood Switch Installed:
 - Defaults to No.
11. Temperature Offset Adjustments:
 - Offset shown in degrees F.
12. High Temperature range from 590°F (310°C) to Low Temperature.
13. Low Temperature range from 350°F (177°C) to High Temperature.
14. Main Fan (Amps):
 - Press <Enter> to see isolated Amp load.
15. Belt Direction:
 - Defaults to right to left.
 - Can be switched from left to right without physically changing the wire belt direction.
16. Main Fan Off Delay:
 - Defaults to auto 225°F (107°C)
17. Beeper Button Test

Conveyor Speed Settings



Read the entire instruction before programming.

TIP

Configuration Key Functions

ENTER = Used to select and save parameters.

HIDDEN = Behind the XLT is a hidden button. This is used along with the up and down button to access the programming mode.

UP = Increases the setting of the selected parameter.

DOWN = Decrease the setting of the selected parameter.

1. To enter conveyor settings press and hold 3 buttons (HIDDEN, UP, and DOWN) for 10 seconds to enter.
2. Displays will show programming screens before auto-exiting after 5 seconds of no activity.



Min Time

Factory default is 90. To change, press ENTER. Use Up/Down arrows to change time which is shown in seconds. Press ENTER to accept and advance.

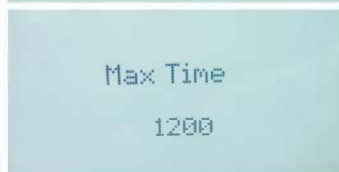

Max Time

Factory default is 1200. To change, press ENTER. For 1832 use 1020 and all other models will be 1200. Use Up/Down arrows to change time which is shown in seconds. Press ENTER to accept and advance.



Sprocket Diameter

Factory default is 1.77. To change, press ENTER. Use Up/Down arrows to change diameter. Press ENTER to accept and advance.



Final Gear Ratio

Factory default is 300. To change, press ENTER. Use Up/Down arrows to change gear ratio. Press ENTER to accept and advance.



Trim Speed

Factory default is 100. To change, press ENTER. Use Up/Down arrows to change trim speed. Press ENTER to accept and advance.

Directional Change of the Conveyor Belt

The conveyor belt is non-directional. This means there is NO physical change of the belt when wanting to change direction; it is now as easy as a programming change. To change the direction:

1. Enter Factory Tech Mode by pressing and holding the 2 arrow buttons for 10 seconds.
2. Press Down arrow to cycle through screens.
3. On Belt Direction, press ENTER and use Up/Down arrows to change.
4. Press ENTER to accept and advance.

Allen Bradley Power Flex 4M Restoring XLT Defaults

**TIP**

Read the entire instruction before programming.

To reset VFD settings change P112 to 1. The VFD will reset to factory default settings. To cycle power, turn circuit breaker off and on and the HMC will load the factory parameters into the VFD.

P105=65	Maximum Frequency
P106=2	Start Source
P108=4	Speed Reference
P110=2	Decel Time
A451=9	Auto Reset Tries
A452=60	Auto Reset Delay
T201=2	Terminal Block Group (I/O) Terminal 5
T202=6	Terminal Block Group (I/O) Terminal 6
A404=60	Jog Frequency

Test run the motor by turning on one of the oven/hood buttons located on the HUI.

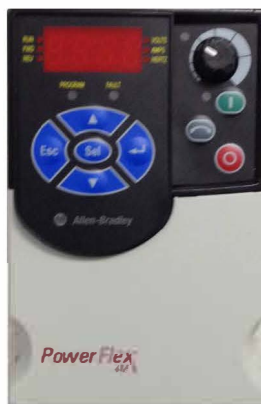

Complete VFD manual available at www.xltovens.com.

VFD Controller Settings						
	Switches On			1832 & 2440	3240 & 3255	3855
	Top	Middle	Bottom			
Single	X			20 Hz	25 Hz	30Hz
Double	X			20 Hz	25 Hz	30Hz
			X	35 Hz	40 Hz	45 Hz
	X		X	35 Hz	40 Hz	45 Hz
Triple	X			20 Hz	25 Hz	30Hz
		X		30 Hz	35 Hz	40 Hz
			X	40 Hz	45 Hz	50 Hz
	X	X		30 Hz	35 Hz	40 Hz
	X		X	40 Hz	45 Hz	50 Hz
		X	X	40 Hz	45 Hz	50 Hz
	X	X	X	45 Hz	50 Hz	55 Hz
Fire Suppression				60 Hz- DO NOT CHANGE		

How to order Parts

Have all information ready when calling XLT. Below is a list of information that is required for all orders. At the bottom of the Bill of Materials (BOM) on the following parts overview pages are additional requirements needed depending on your parts order.

Oven/Hood information required:

- Model #
- Serial #
- Manufacture Date
- Phone #
- Contact name
- Bill to
- Ship to
- Credit card information

P.O.R = Price On Request

All prices are subject to change, contact XLT for current prices.

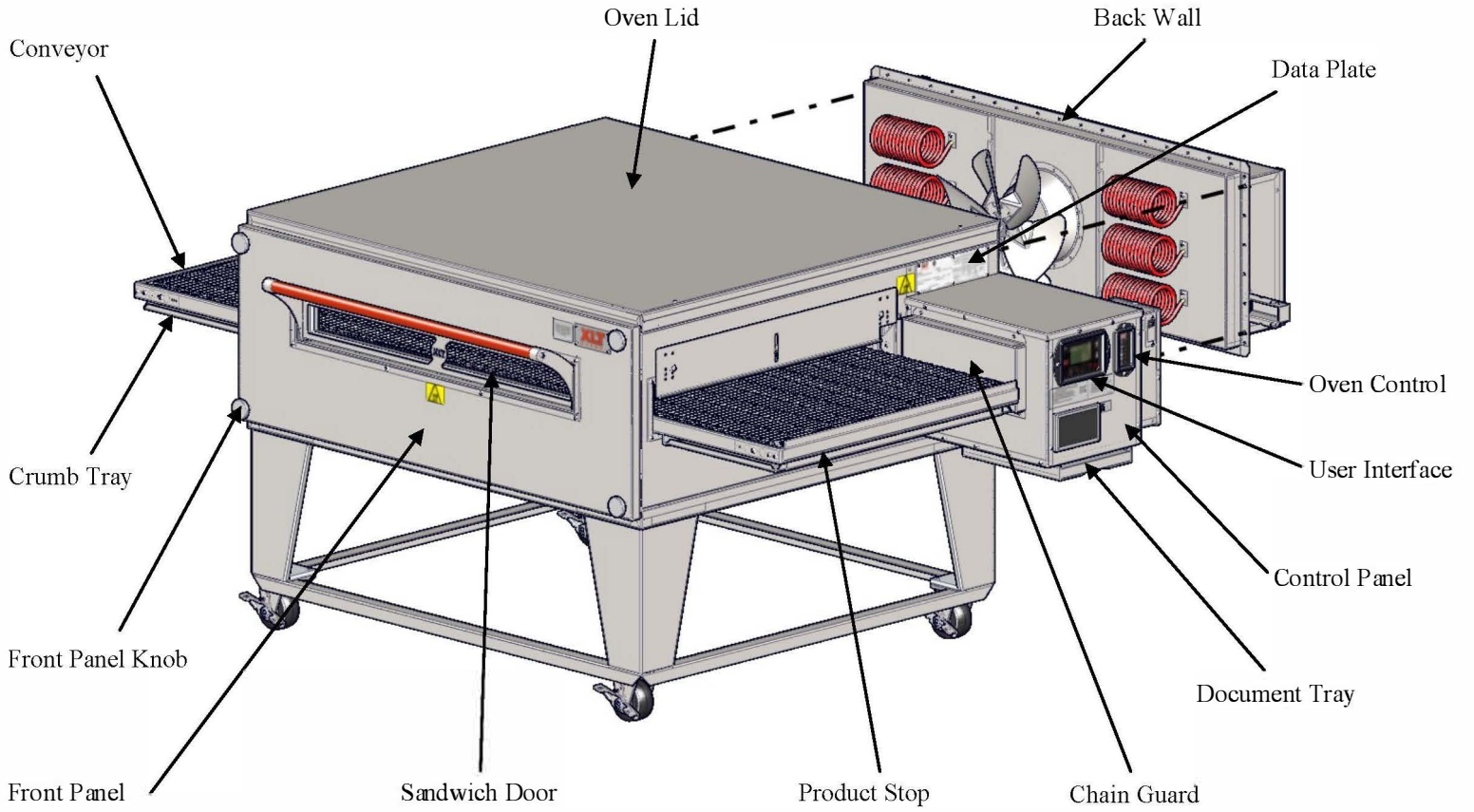

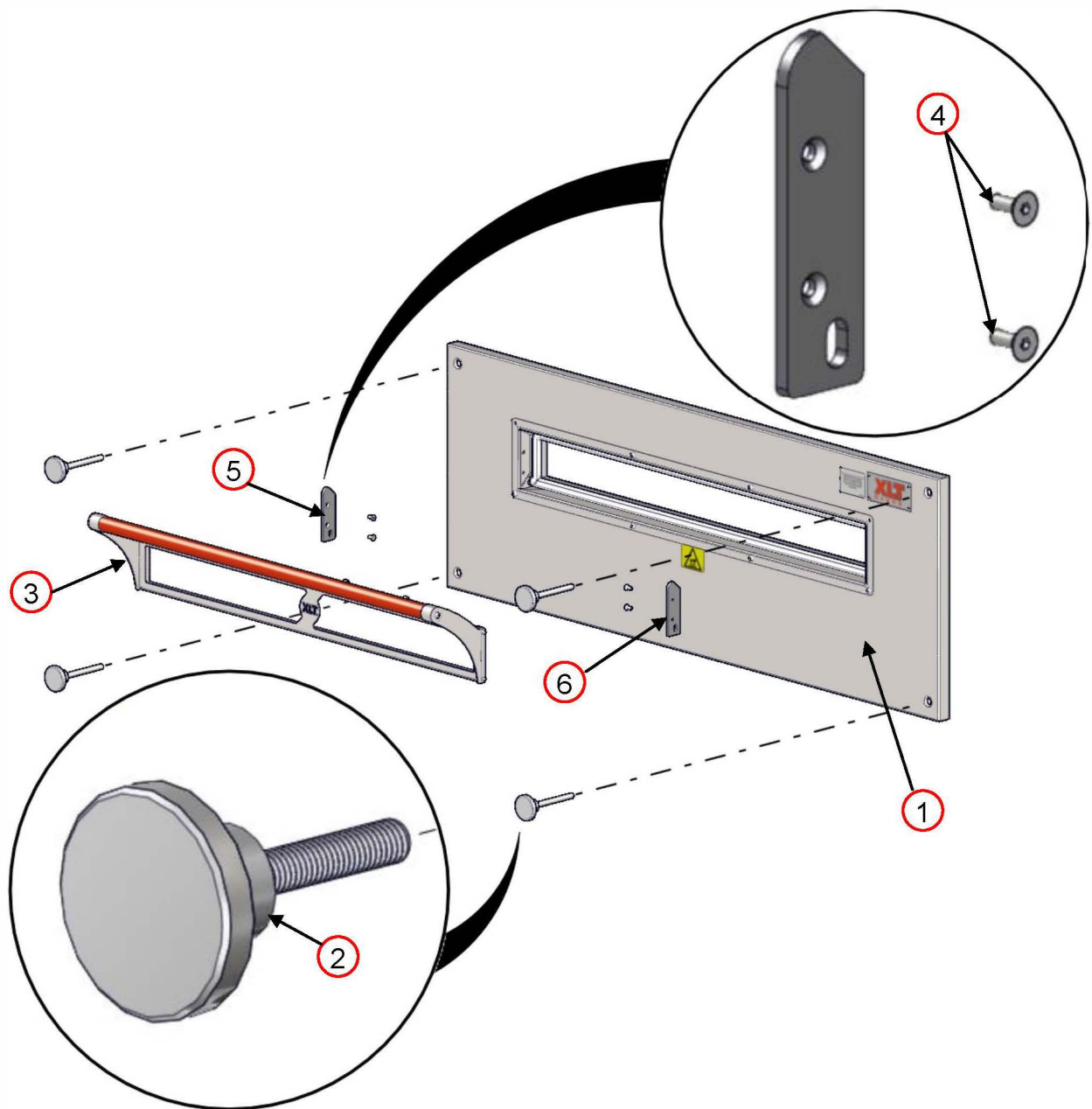

FRONT PANEL			
ITEM	PART NUMBER	DESCRIPTION	YOUR PRICE
1	XA 6500	Front Panel Assembly	P.O.R
2	XA 6505	Front Panel Knob	\$15.90
3	XA 6600	Sandwich Door	P.O.R
4	XF 126-2	Screw 10-24	P.O.R
5	XM 6703	Door Retainer Left	\$13.80
6	XM 6704	Door Retainer Right	\$13.80

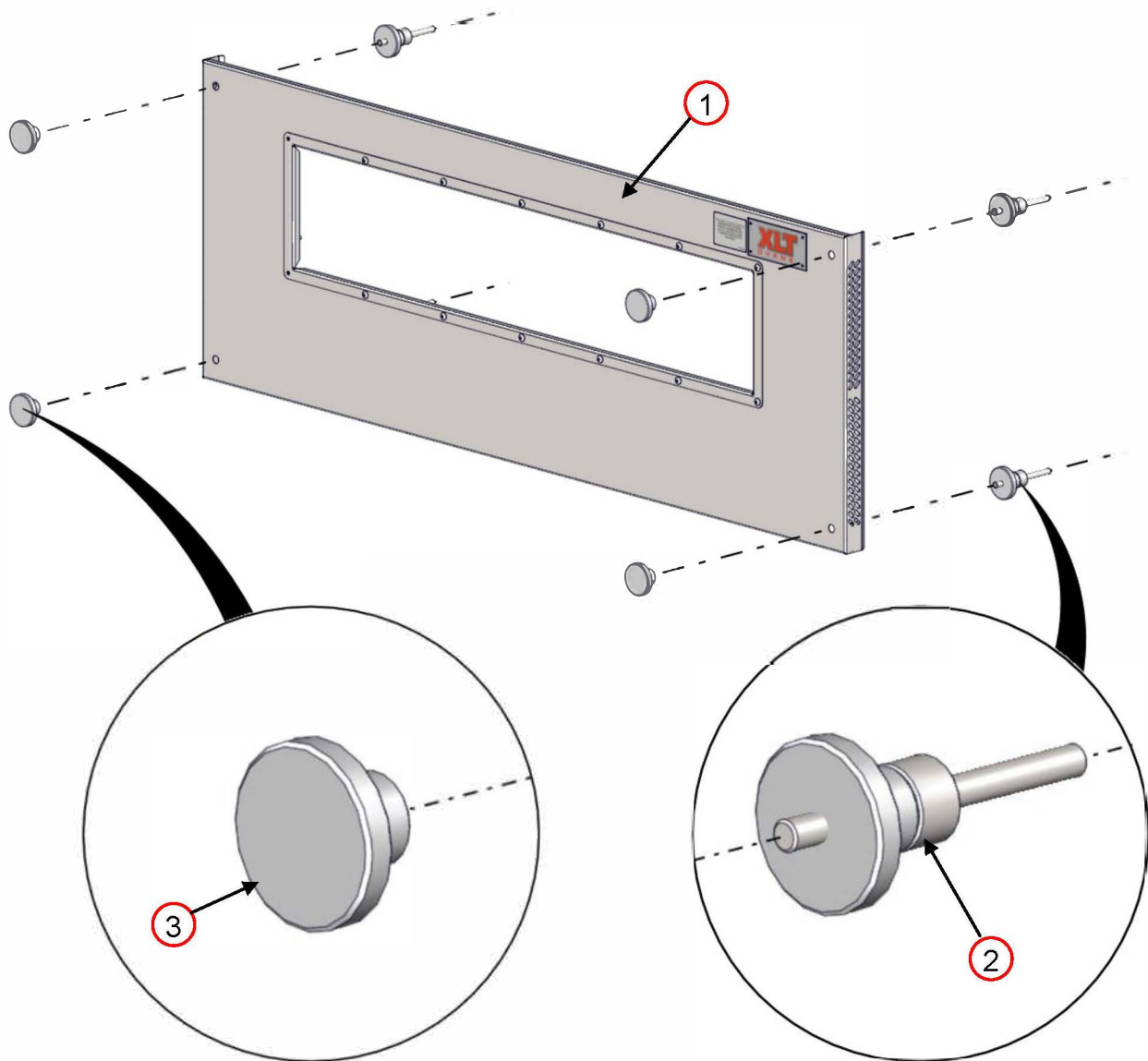

EXTENDED FRONT PANEL			
ITEM	PART NUMBER	DESCRIPTION	YOUR PRICE
1	XA 6700	Extended Front Panel	P.O.R
2	XA 6504	Front Panel Knob Assy Ext Frt	\$33.09
3	XP 6505	Front Panel Knob	\$14.49

Front Panel information required:

- Size of Oven
- Short or Long Window
- Stainless or Wood Handle
- 3” or 5” Window Opening

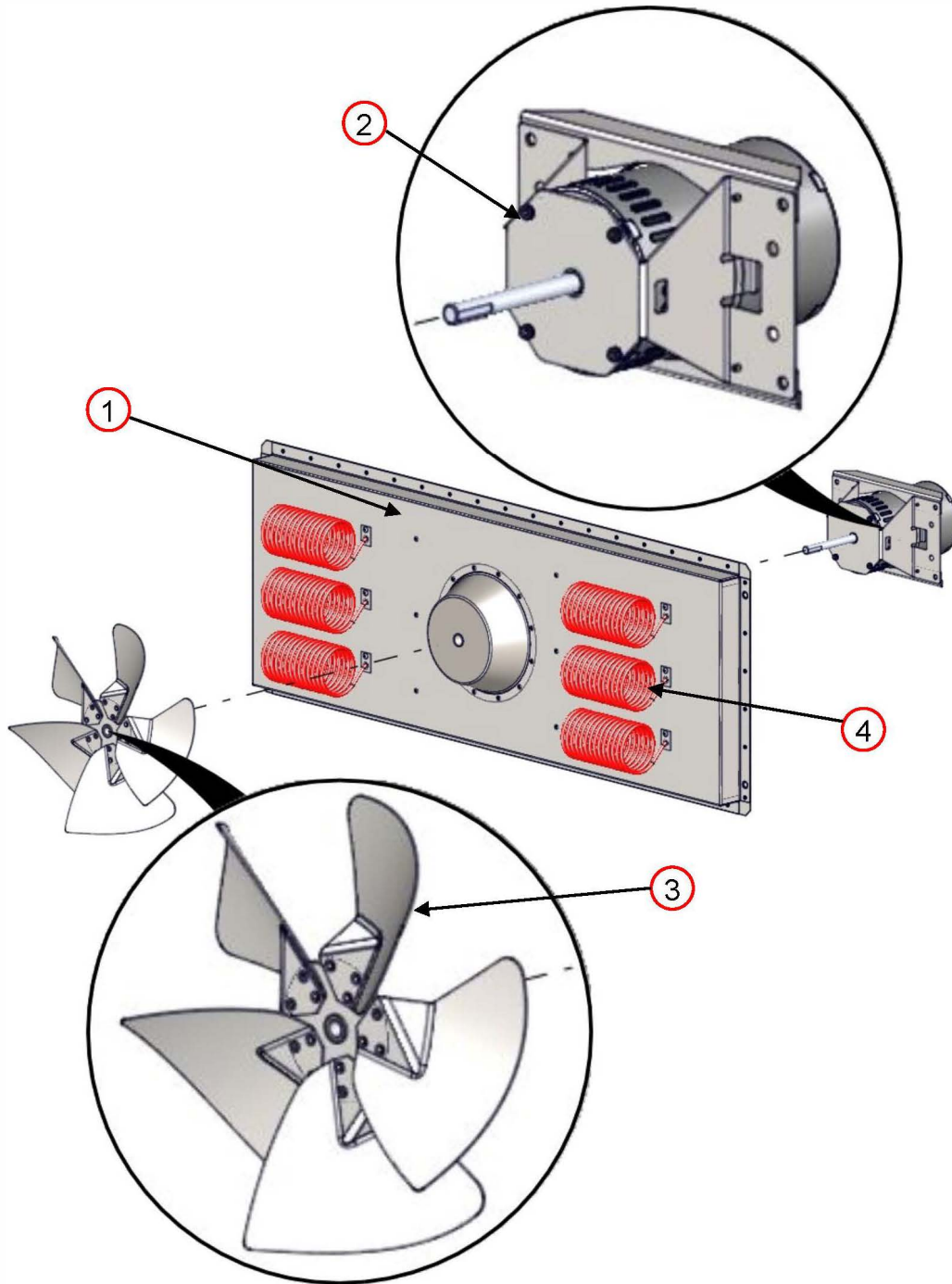

Electric Oven Elements								
Oven Size	208V-4500W	Qty	240V-4500W	Qty	208V-5300W	Qty	240V-5300W	Qty
1832-208 V					x	3		
1832-240 V							x	3
1832-380 V							x	3
2440-208 V	x	6						
2440-240 V			x	6				
2440-380 V			x	6				
3240-208 V	x	6						
3240-240 V			x	6				
3240-380 V			x	6				
3255-208 V					x	6		
3255-240 V							x	6
3255-380 V							x	6
3855-208 V					x	6		
3855-240 V							x	6
3855-380 V							x	6

BACK WALL			
ITEM	PART NUMBER	DESCRIPTION	YOUR PRICE
1	XA 5001	Back Wall Assembly	P.O.R
2	SP 5009A-75	Fan Motor w/ Mount 3/4 HP	\$283.20
3	XA 5200	Fan Blade	P.O.R
4	XP 5201/5202	Heating Element	P.O.R

Back Wall information required:

- Size of Oven
- Voltage

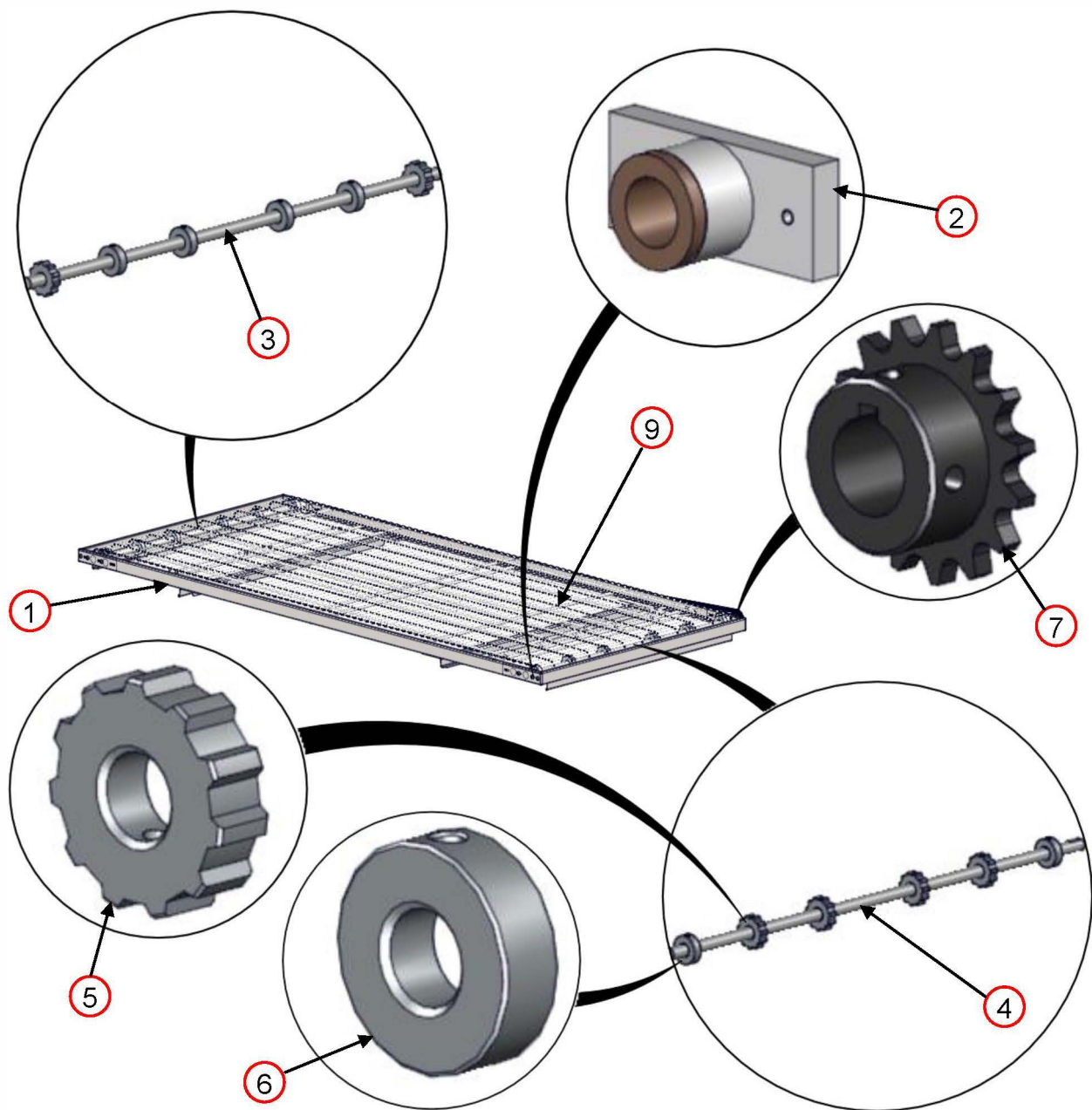

Conveyor Drive Chain not shown

CONVEYOR			
ITEM	PART NUMBER	DESCRIPTION	YOUR PRICE
1	XA 7000	Conveyor Assembly	P.O.R
2	XA 7200	Conveyor Bearing Assembly	\$9.30
3	XM 7301	Conveyor Shaft Idle	P.O.R
4	XM 7302	Conveyor Shaft Drive	P.O.R
5	XP 7403	Conveyor Roll Notched	\$12.20
6	XP 7404	Conveyor Roll Plain	\$11.00
7	XP 9503	Conveyor Sprocket Driven 15	\$15.50
8	XP 9504	Conveyor Drive Chain	\$23.60
9	XP 9506	Conveyor Belt	P.O.R

Conveyor information required:

- Oven Size
- Split Belt or Standard Belt

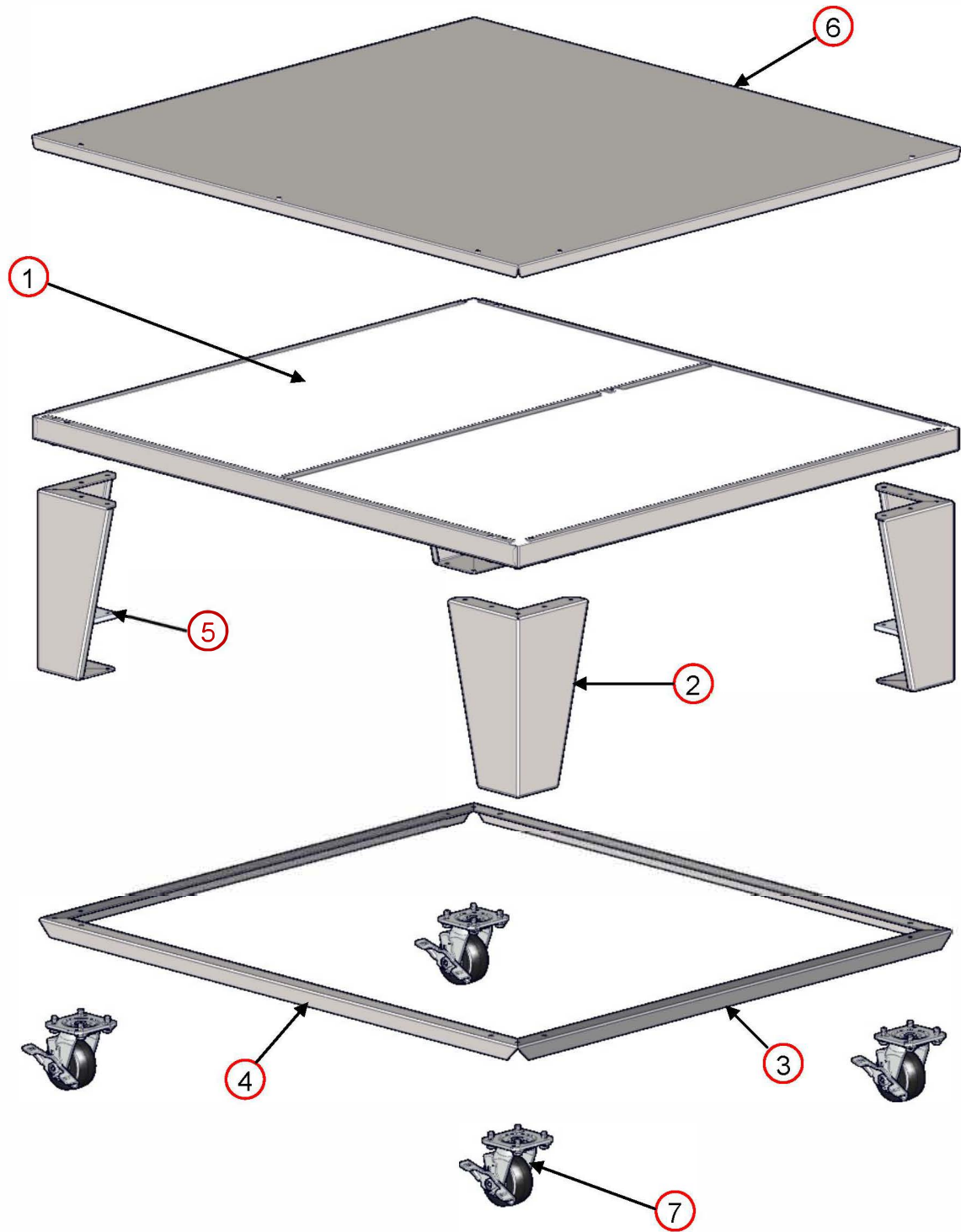

BASE			
ITEM	PART NUMBER	DESCRIPTION	YOUR PRICE
1	XA 1001	Base Assembly	P.O.R
2	XM 1003-15	Base Leg	\$65.40
3	XM 1006	Side Leg Angle	P.O.R
4	XM 1007	Front/Back Leg Angle	P.O.R
5	XM 1008	Bolster Plate	\$11.50
6	XM 1010	Oven Lid	P.O.R
7	XP 1004	Caster	\$21.60

Base information required:

- Size of Oven
- Single, Double, or Triple Stack

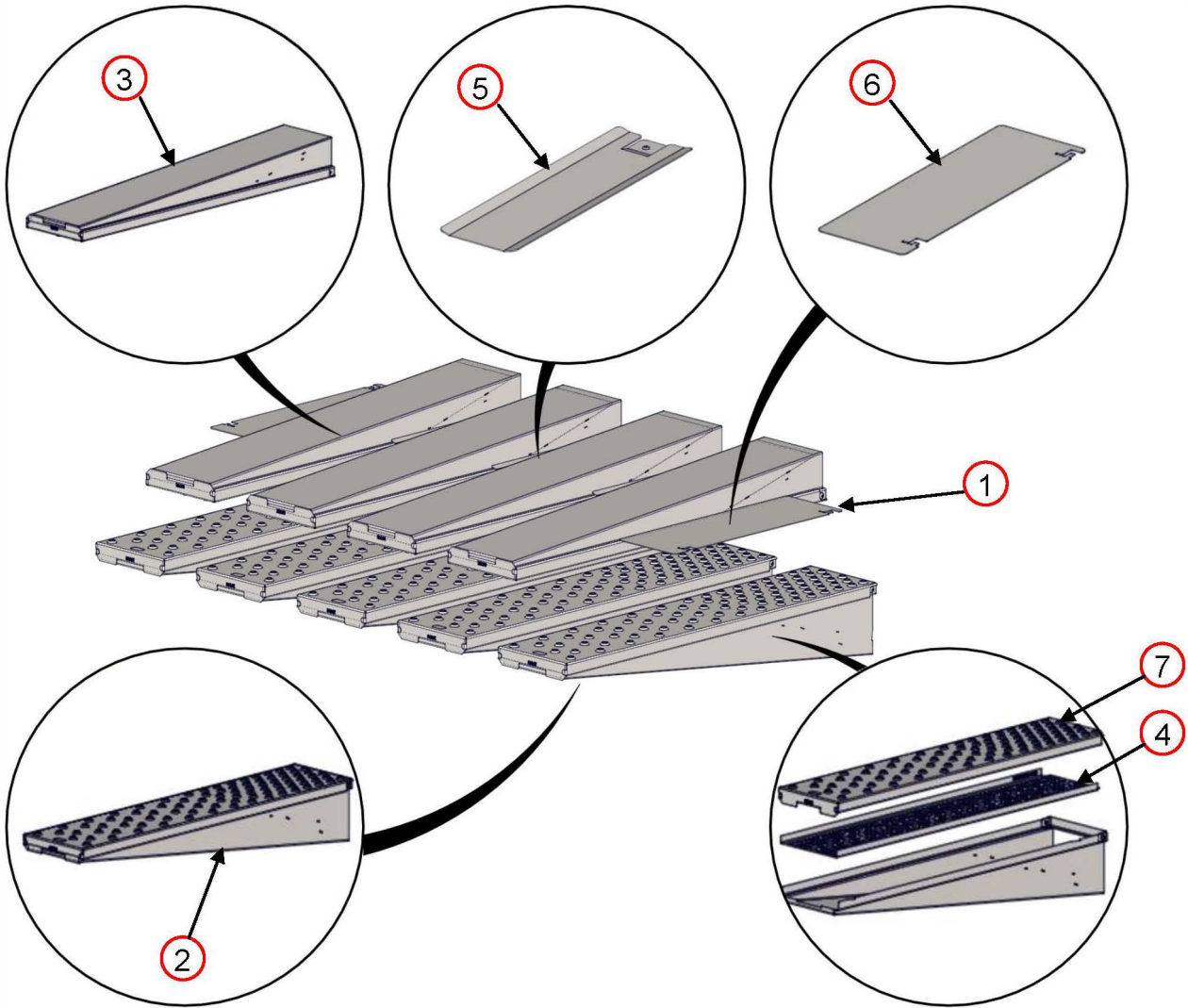

FINGERS			
ITEM	PART NUMBER	DESCRIPTION	YOUR PRICE
1	XA 8XXXX	Finger Group Assembly	P.O.R
2	XA 8001-B	Finger Body Bottom	P.O.R
3	XA 8001-T	Finger Body Top	P.O.R
4	XM 8004	Finger Inner Plate Perforated	P.O.R
5	XM 8009-S	Finger Block Off Snap	\$12.60
6	XM 8024	EndLoss Plate	P.O.R
7	XM 8025	EndLoss Plate	P.O.R
8	XM 8XXX	Finger Outer Plate	P.O.R

Finger information required:

- Size of Oven
- Customer name
- Part number on front of finger outer

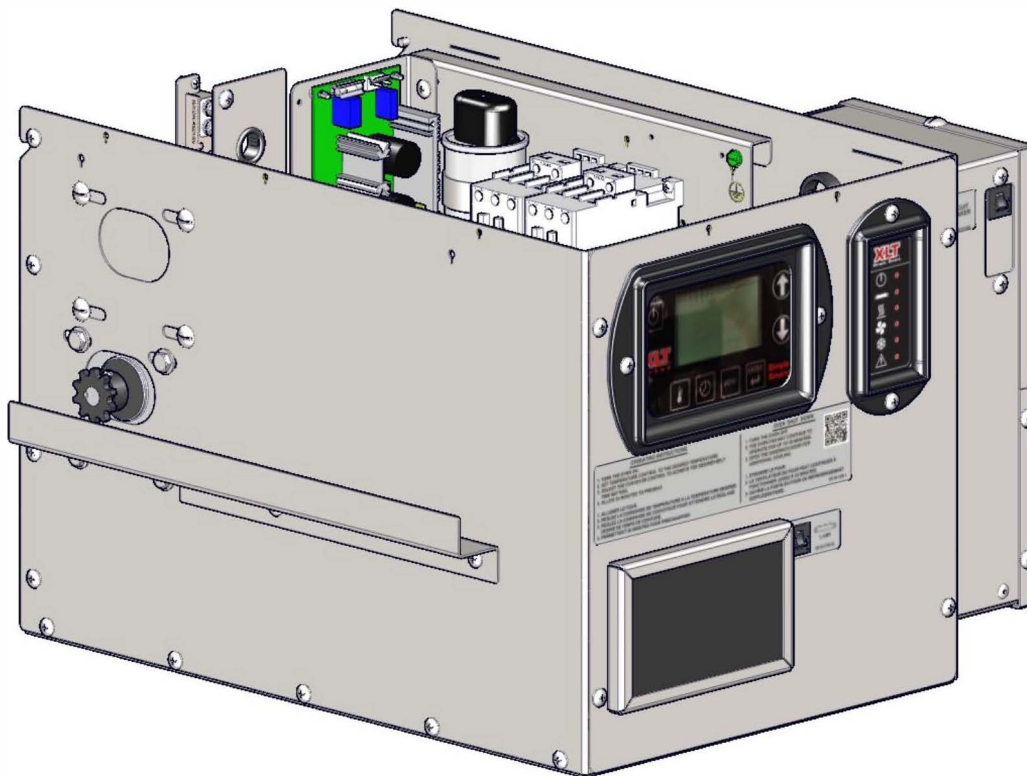

Operating Position (shown with lid removed)

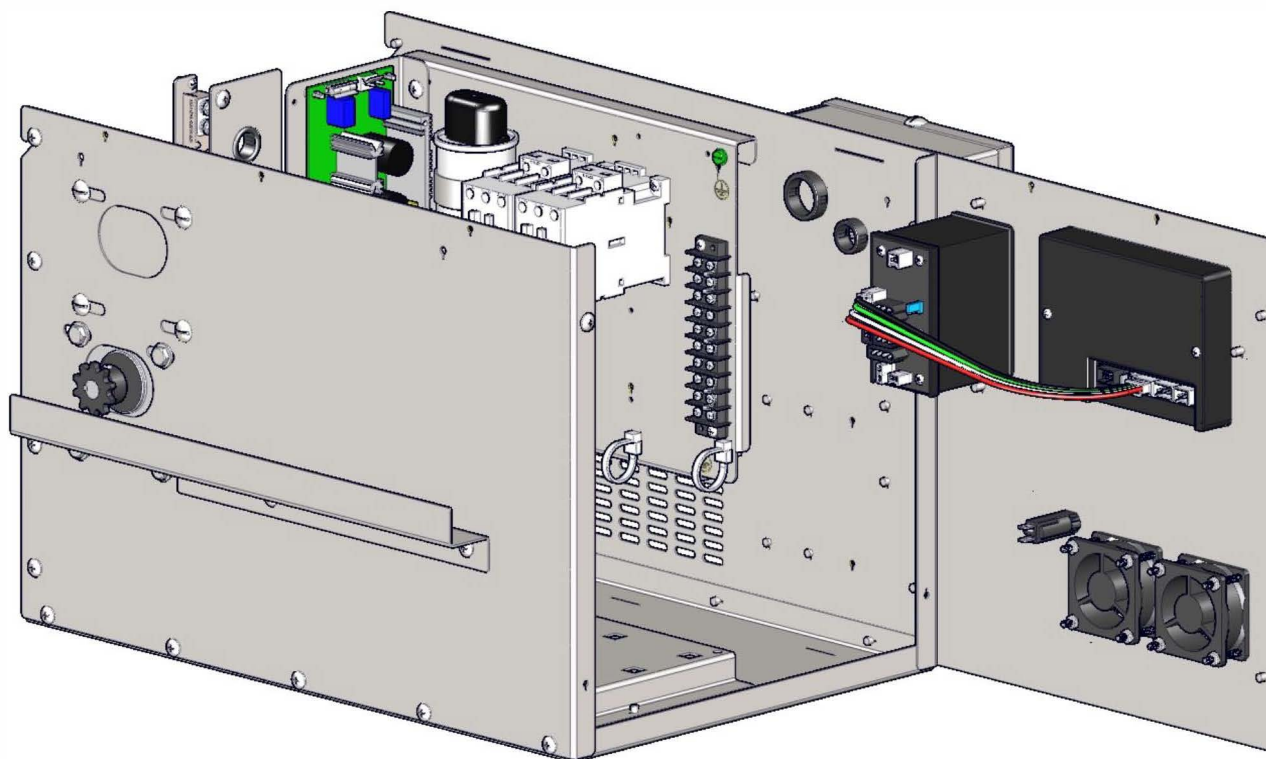

Service Position



CONTROL PANEL			
ITEM	PART NUMBER	DESCRIPTION	YOUR PRICE
1	SP 4520-EL	Fan Guard / Filter Holder	\$9.30
2	XP 4170-LUI	Large User Interface	P.O.R
3	XP 4175-MC	Oven Control	P.O.R
4	XP 4501-EL	FPPG Fan EL M2	\$35.20
5	XP 4515-CB	Circuit Breaker	\$6.95
6	XP 4520-EL	Fan Filter	\$1.95

Control Panel information required:

- Size of Oven
- Voltage
- Circuit Breaker amp rating
- Conveyor Belt direction

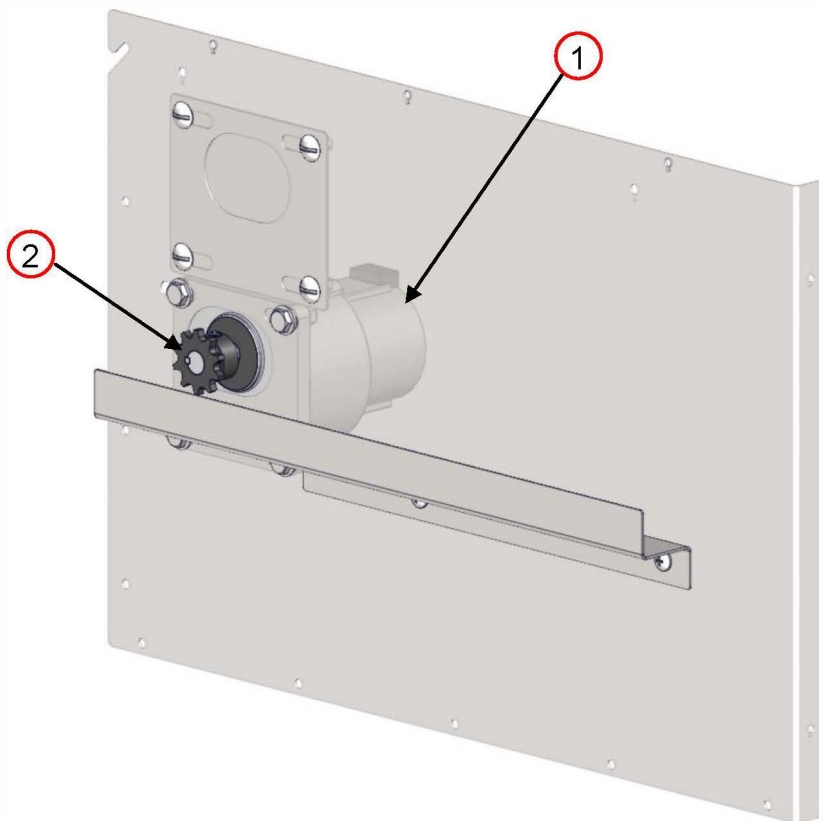

CONTROL BOX FRONT			
ITEM	PART NUMBER	DESCRIPTION	YOUR PRICE
1	XA 4117-12.5 RPM STD	Conv Motor Assy 12.5 RPM STD	\$305.30
2	XP 4155	Sprocket Conveyor Drive 10T	\$15.70

Control Box Front information required:

- Size of Oven
- Split Belt or Standard Belt

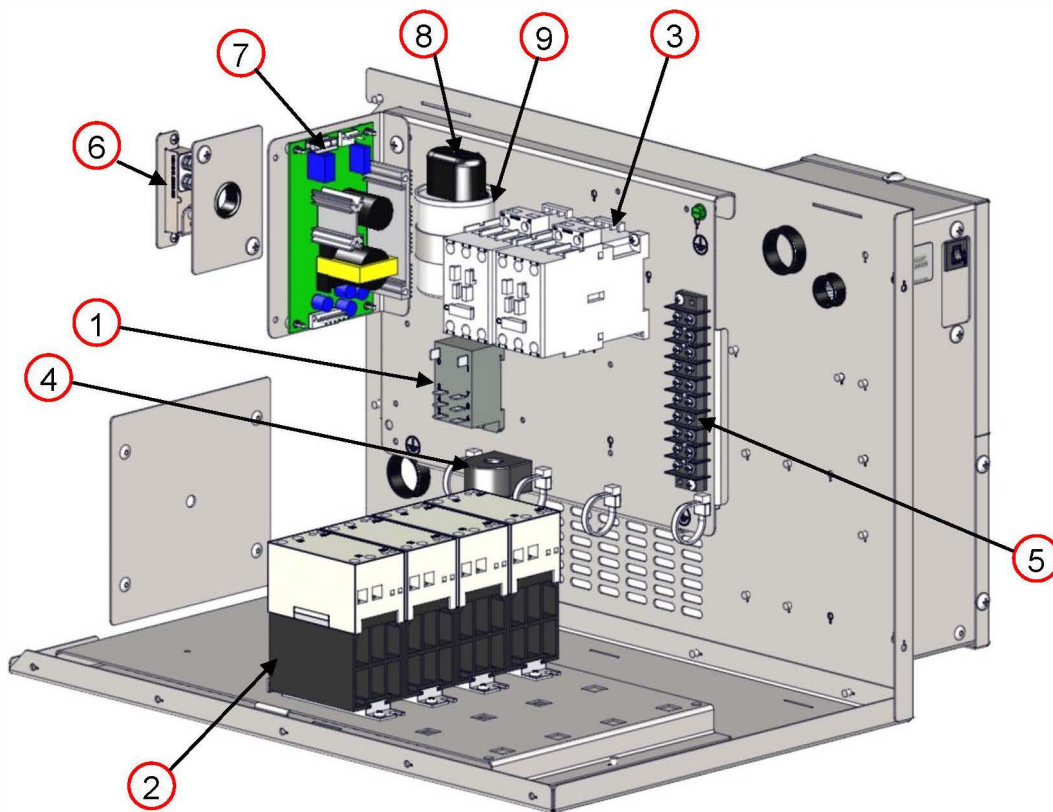

CONTROL BOX BACK			
ITEM	PART NUMBER	DESCRIPTION	YOUR PRICE
1	HP 2067A-24VDC	Relay 8 Pin 30A 24VDC	P.O.R
2	XP 4305-50	Relay 50A Solid State	\$159.70
3	XP 4306A-50	50 Amp 3 Phase Contactor	\$236.60
4	XP 4310A	Current Sensor	P.O.R
5	XP 4701A-10	Terminal Strip 10 Place	P.O.R
6	XP 4713A	High Temp Limit Switch S3	\$53.10
7	XP 4716	Power Supply PS	\$32.40
8	XP 5012	Capacitor Boot	\$2.30
9	XP 5014-30	Capacitor Baldor 3/4 HP 30uF	\$18.60

Control Box Back information required:

- Size of Oven
- Voltage

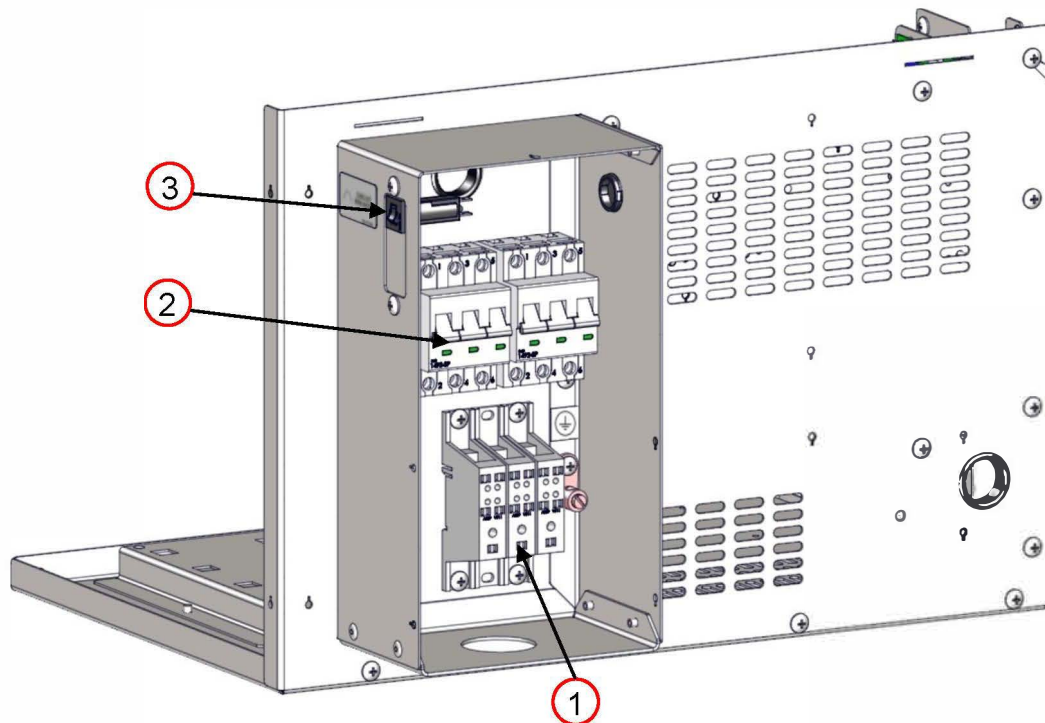

CONTROL BOX REAR			
ITEM	PART NUMBER	DESCRIPTION	YOUR PRICE
1	XP 4302A	1 Pole Power Block Electric	P.O.R
2	XP 4303	3 Pole Circuit Breaker EL	\$160.40
3	XP 4515-CB-0.5A	1/2 Amp Circuit Breaker	P.O.R

Control Box Rear information required:

- Size of Oven
- Voltage

This page intentionally left blank.

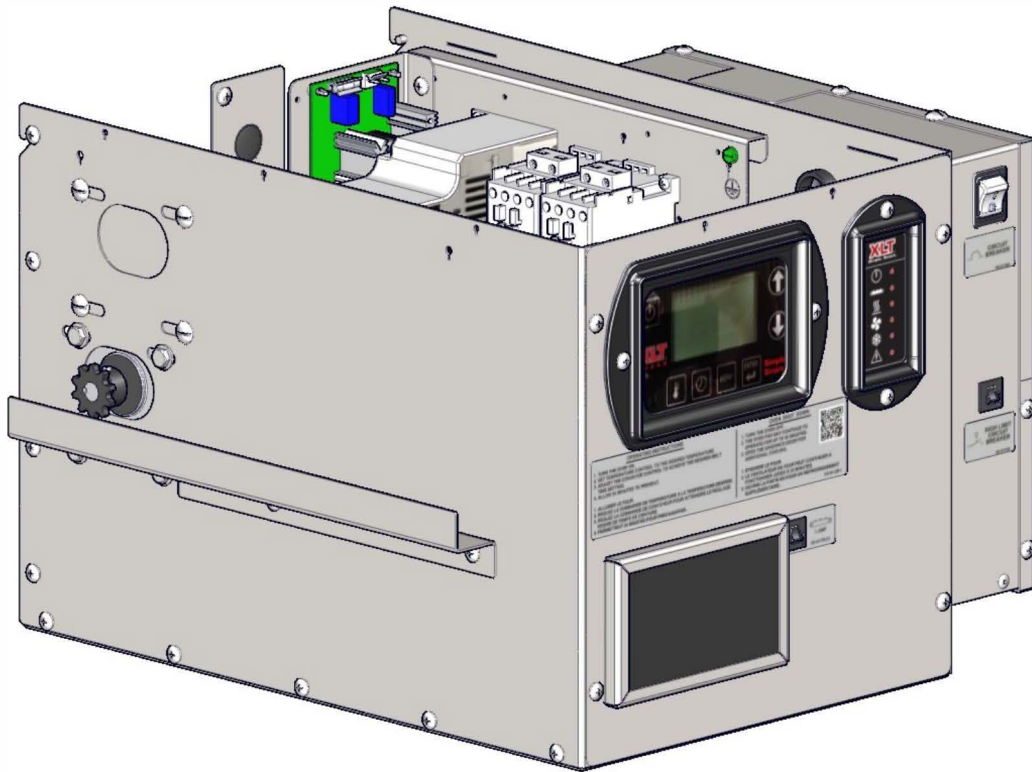

Operating Position (shown with lid removed)

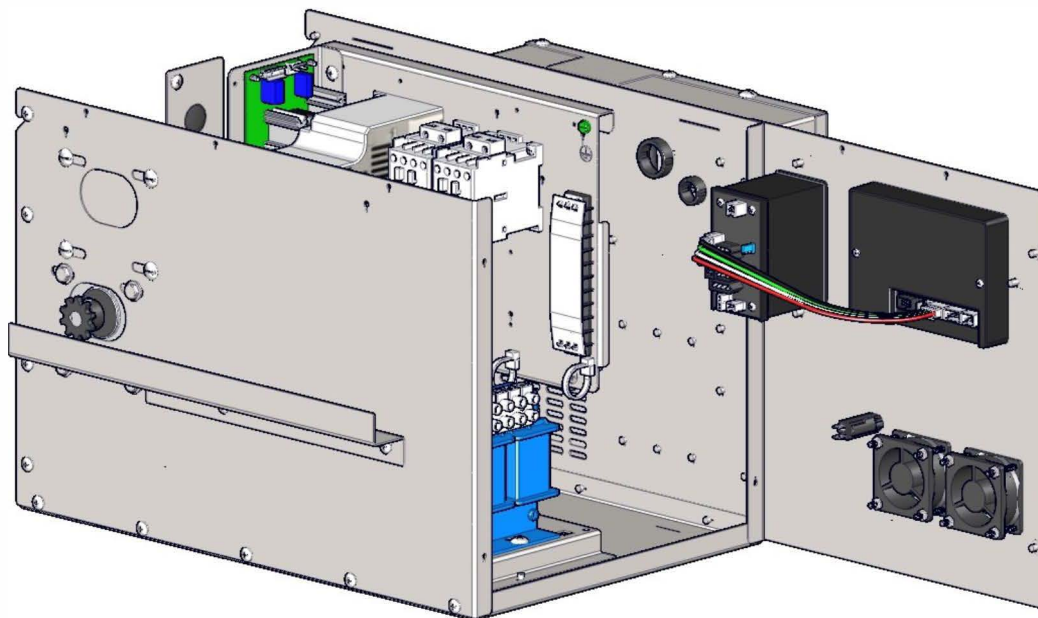

Service Position



CONTROL PANEL			
ITEM	PART NUMBER	DESCRIPTION	YOUR PRICE
1	SP 4520-EL	Fan Guard / Filter Holder	\$9.30
2	XP 4170-LUI	Large User Interface	P.O.R
3	XP 4175-MC	Oven Control	P.O.R
4	XP 4501-EL	FPPG Fan EL M2	\$35.20
5	XP 4515-CB	Circuit Breaker	\$6.95
6	XP 4520-EL	Fan Filter	\$1.95

Control Panel information required:

- Size of Oven
- Voltage
- Circuit Breaker amp rating
- Conveyor Belt direction

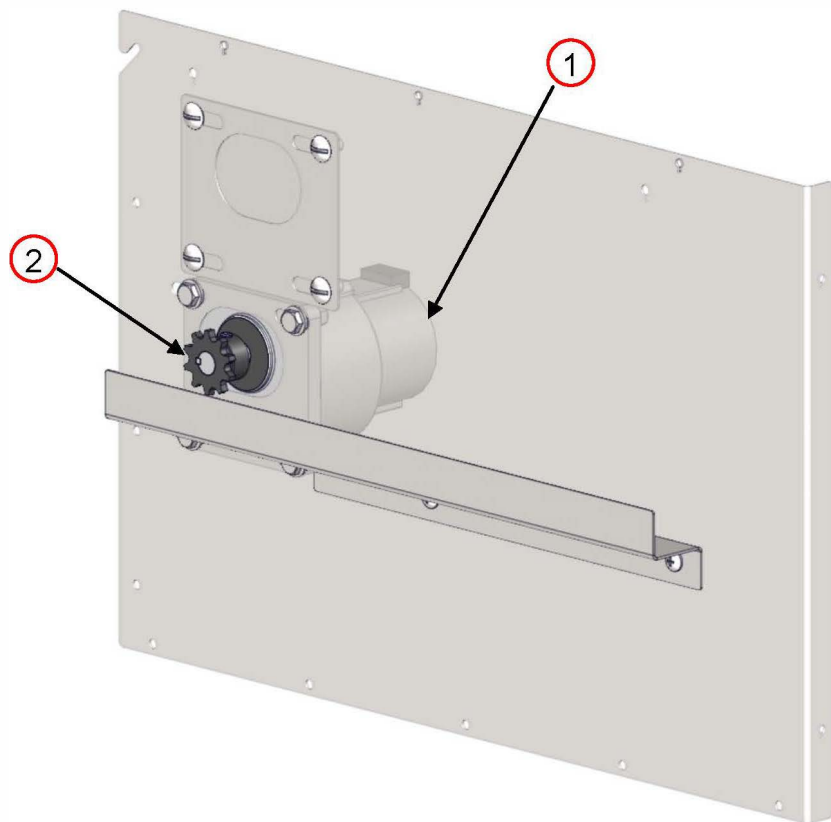

CONTROL BOX FRONT			
ITEM	PART NUMBER	DESCRIPTION	YOUR PRICE
1	XA 4117-12.5 RPM STD	Conv Motor Assy 12.5 RPM STD	\$305.30
2	XP 4155	Sprocket Conveyor Drive 10T	\$15.70

Control Box Front information required:

- Size of Oven
- Split Belt or Standard Belt

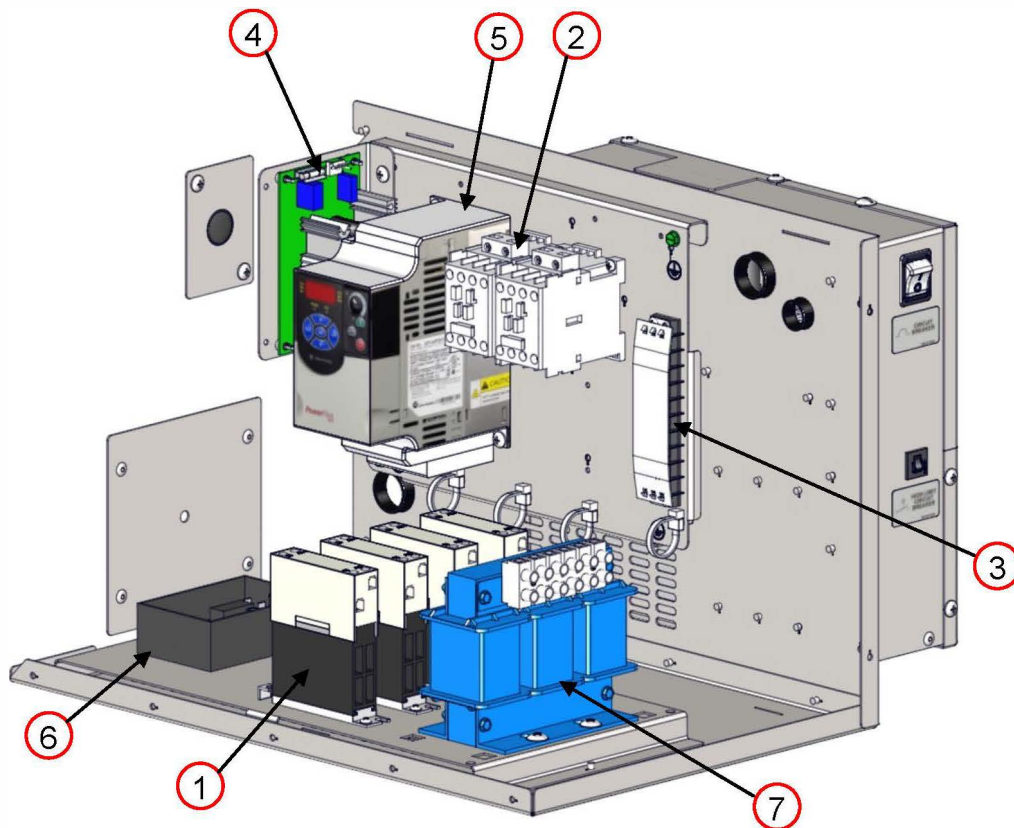

CONTROL BOX BACK			
ITEM	PART NUMBER	DESCRIPTION	YOUR PRICE
1	XP 4305A-30	Relay 30A Solid State	\$176.20
2	XP 4306B-30	30 Amp 3 Phase Contactor	\$195.80
3	XP 4701A-10	Terminal Strip 10 Place	P.O.R
4	XP 4716	Power Supply PS	\$32.40
5	XP 4718-4.2	VFD Allen Bradley Power Flex 4M	P.O.R
6	XP 4720A-LS	Watlow LS High Temp Cont	P.O.R
7	XP 4722A	3 PH 5% Line Reactor	P.O.R

Control Box Back information required:

- Size of Oven
- Voltage

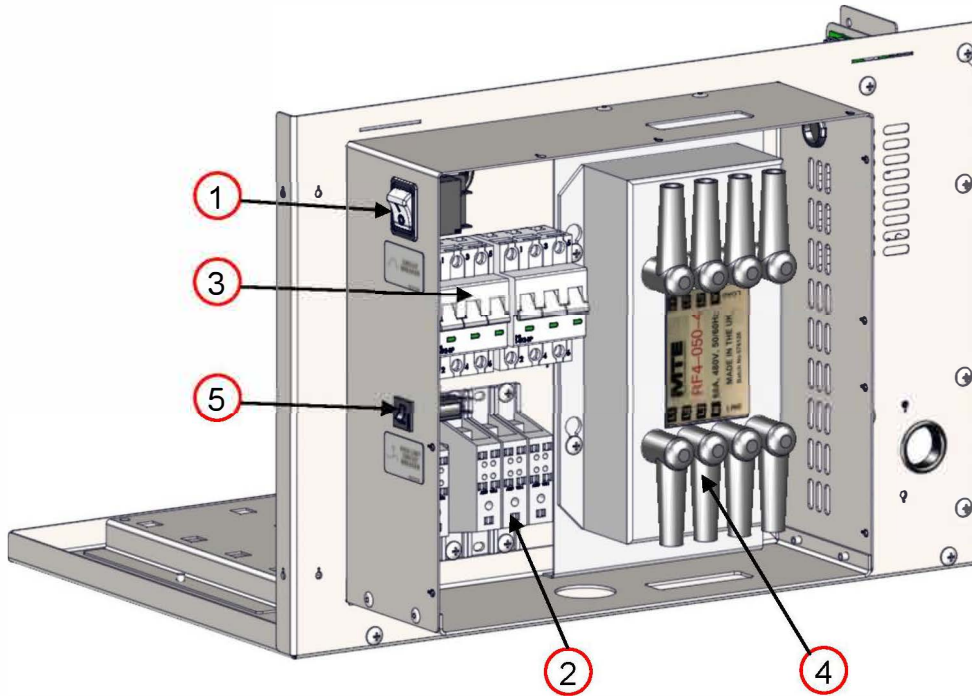

CONTROL BOX REAR			
ITEM	PART NUMBER	DESCRIPTION	YOUR PRICE
1	HP 2060A	Circuit Breaker Exh Fan	P.O.R
2	XP 4302A	1 Pole Power Block Electric	\$16.80
3	XP 4303	3 Pole Circuit Breaker EL	\$160.40
4	XP 4304A	Filter EMI 4 Wire	P.O.R
5	XP 4515-CB-0.5A	1/2 Amp Circuit Breaker	P.O.R

Control Box Rear information required:

- Size of Oven
- Voltage

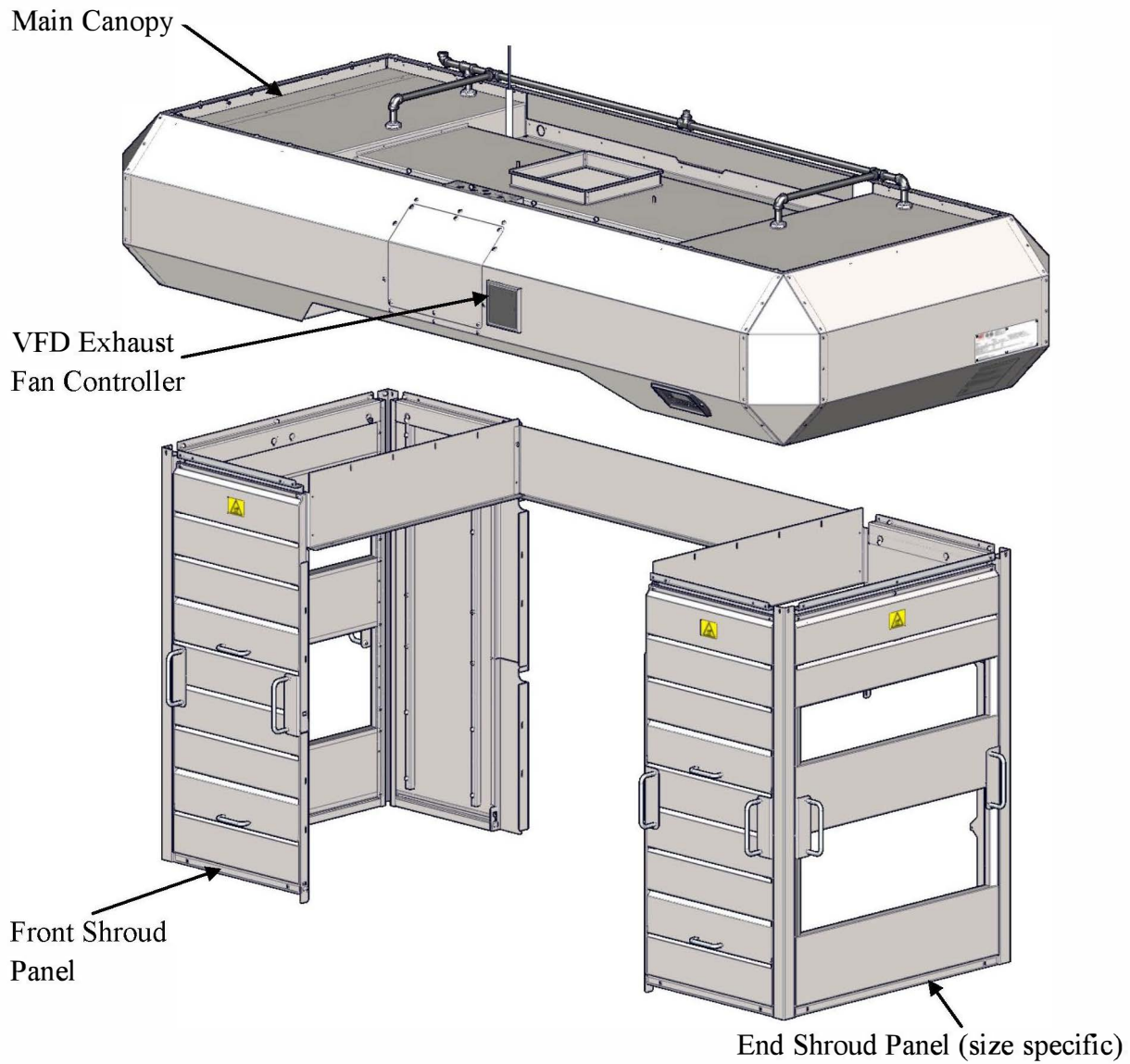

VFD Control Box w/Fire Suppression

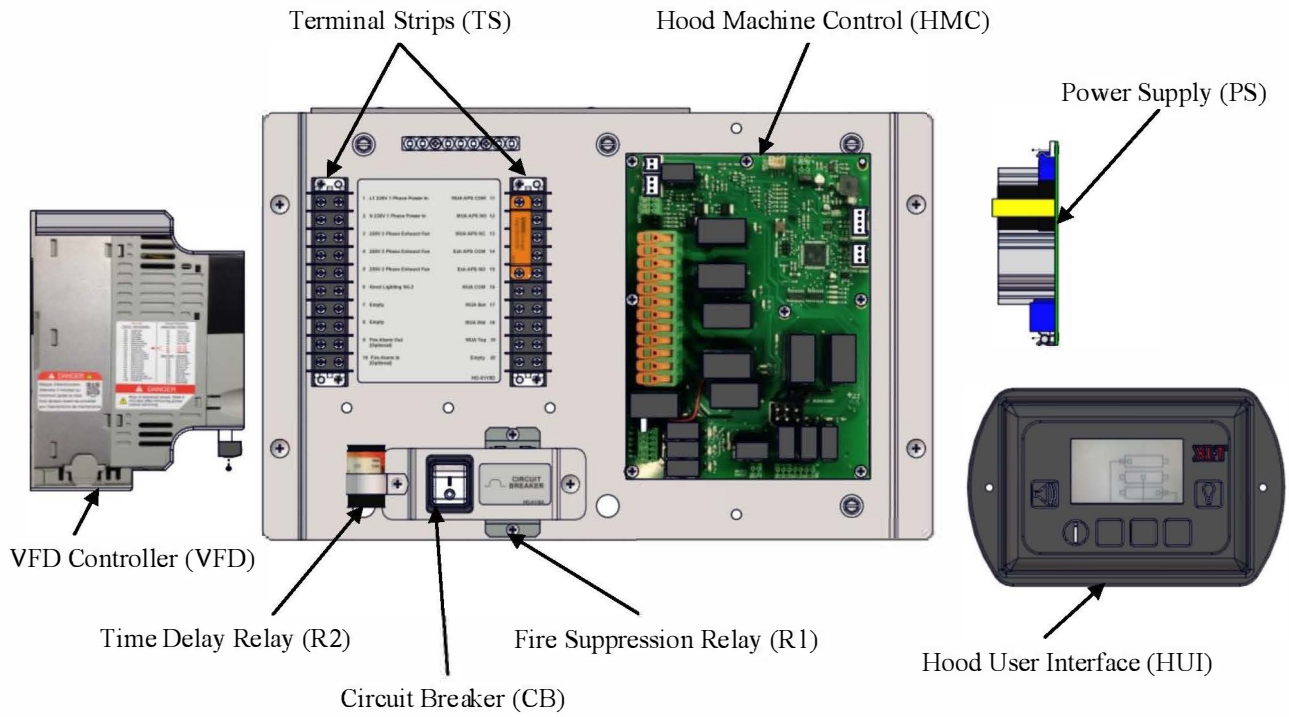

VFD Control Box (Cover removed)

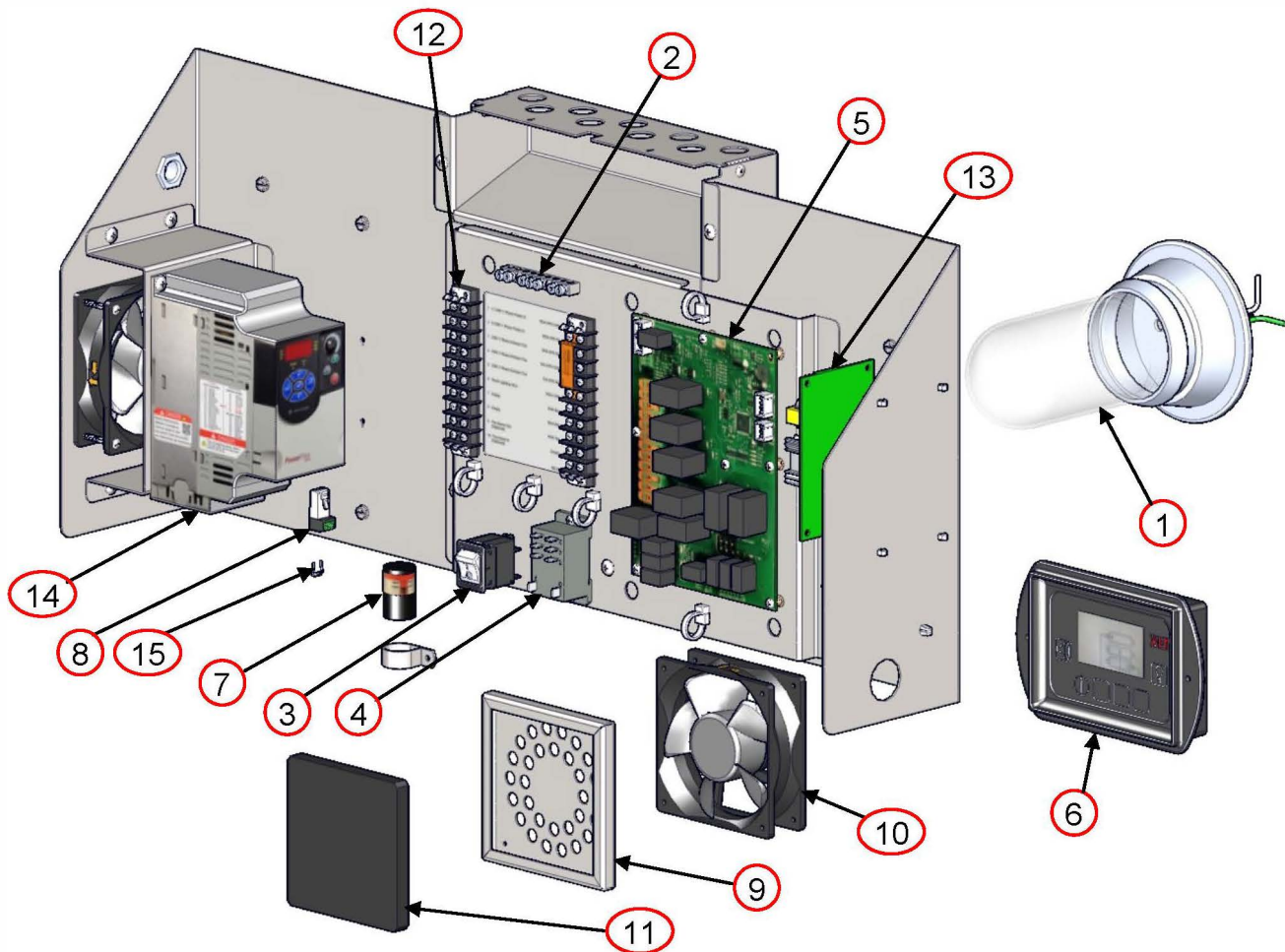

VFD W/ FIRE SUPPRESSION			
ITEM	PART NUMBER	DESCRIPTION	YOUR PRICE
1	HP-1251	Light Assembly	\$57.80
2	HP-2058	Ground Bar 7 POS	\$55.70
3	HP-2060	Circuit Breaker Exhaust Fan	\$52.30
4	HP-2067-24VDC	Relay 8 Pin 30A 24 VDC	\$23.70
5	HP-2070-MC	Hood Machine Control	P.O.R
6	HP-2071-UI	Hood User Interface	P.O.R
7	HP-2072	Time Delay Relay R2	P.O.R
8	HP-4718-RJ45	RJ45 Terminal Block	\$2.30
9	SP-4520-GA	Fan Guard / Filter Repl Kit GA	\$5.60
10	XP-4501-GA	FPPG Fan Gas M2	P.O.R
11	XP-4520-GA	Fan Filter	\$1.95
12	XP-4701-10	Terminal Strip 10 Place	\$7.00
13	XP-4716	Power Supply	\$32.40
14	XP-4718-4.2	VFD Allen Bradley Power Flex 4M	P.O.R
15	XW-2900	120 Ohm Terminating Resistor	P.O.R

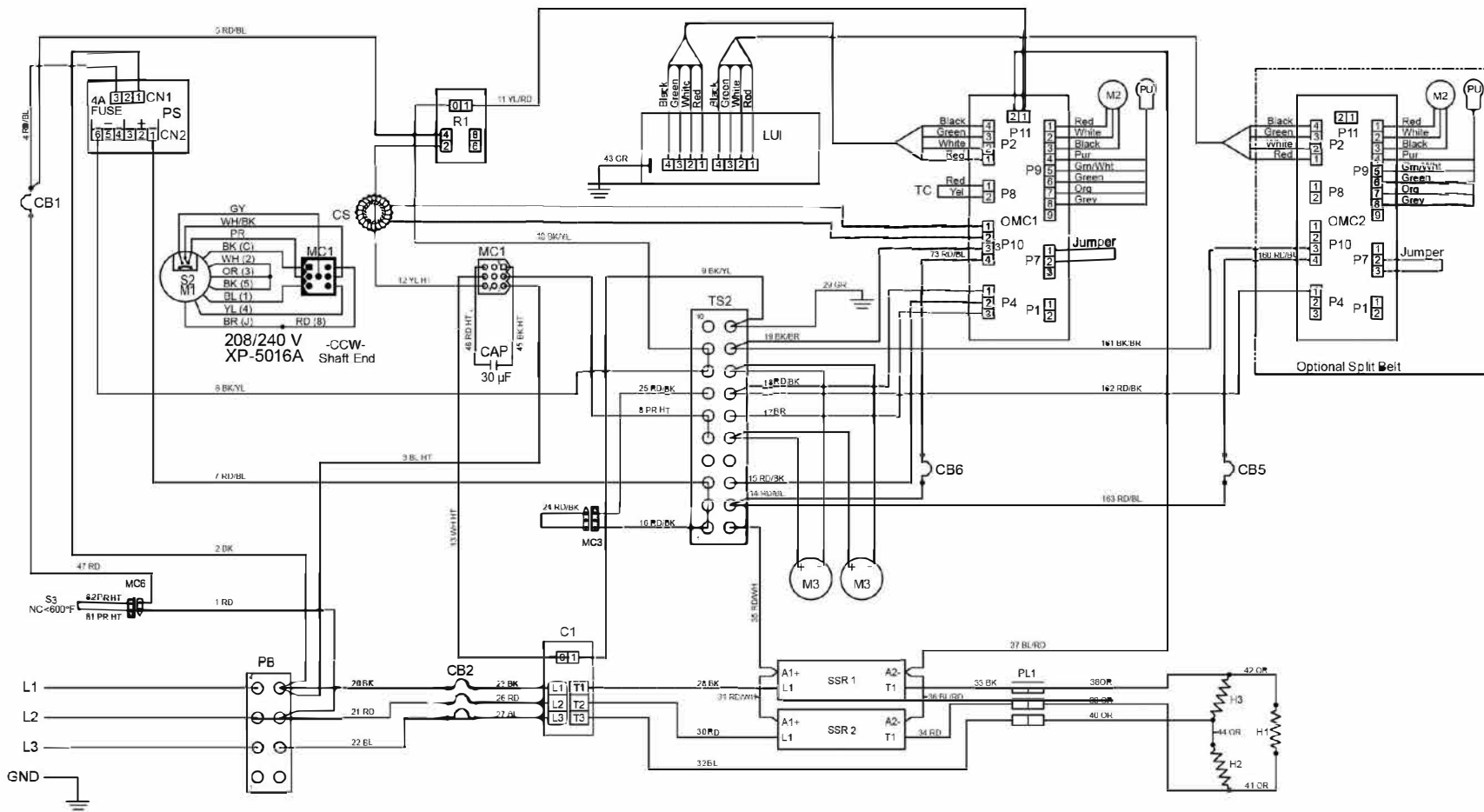

- | | | | | | |
|-------|---|------|--------------------------|------|---------------------------|
| C1 | Contactor 50 Amp | M1 | Motor, Oven Fan | PU | Pick-Up |
| CAP | Capacitor 30µF | M2 | Motor, Conveyor | R1 | Oven Fan Motor Relay |
| CB1 | Circuit Breaker, 10 Amp, Main | M3 | Motor, Cooling Fan | S2 | Switch, Centrifugal |
| CB2 | Circuit Breaker, 63 Amp, Heating Elements | OMC1 | Oven Control, Main | S3 | Switch, High Limit |
| CB5 | Circuit Breaker, ½ Amp, Conveyor Motor | OMC2 | Oven Control, Split Belt | SSR1 | Solid State Relay, 50 Amp |
| CB6 | Circuit Breaker, ½ Amp, Conveyor Motor | PB | Power Block | SSR2 | Solid State Relay, 50 Amp |
| CS | Current Sensor | PL1 | Push Lock, 1-3 Elements | TC | Thermocouple |
| H1-H3 | Heating Element, 208 or 240 VAC, 5300 W | PS | Power Supply | TS2 | Terminal Strip |
| LUI | Large User Interface | | | | |
- RD-Red BK-Black BL-Blue BR-Brown GR-Green YL-Yellow PR-Purple HT-High Temp OR-Orange WH-White GY-Gray

X3F-1832

208/240 VAC 3 PH 60 Hz
XD-9130F-208/240-5300-3

Right Side
08/15/2016

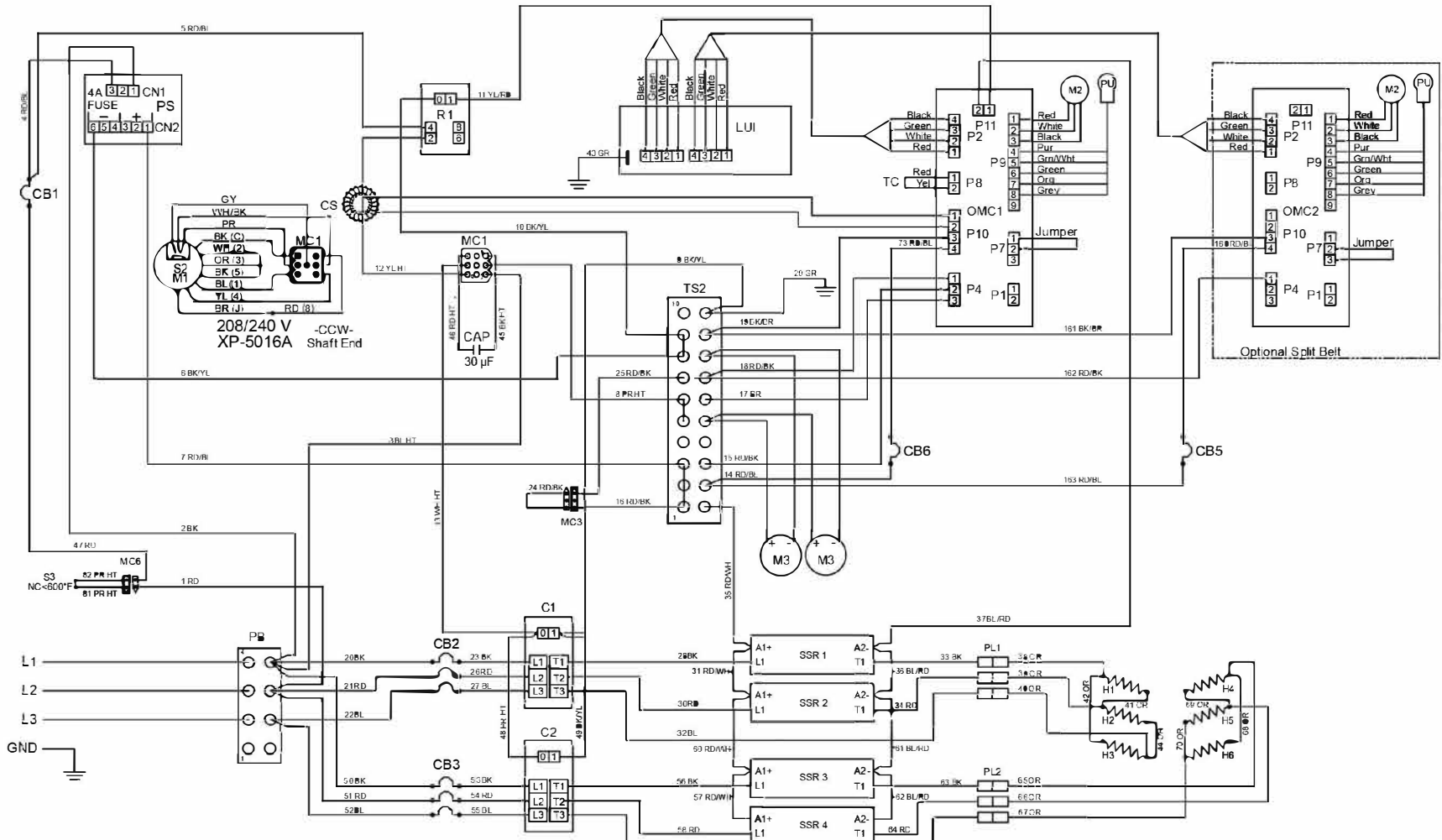

- | | | | | | |
|-------|---|--------|--------------------------|---------|---------------------------|
| C1 | Contactor 50 Amp | LUI | Large User Interface | PU | Pick-Up |
| C2 | Contactor 50 Amp | M1 | Motor, Oven Fan | R1 | Oven Fan Motor Relay |
| CAP | Capacitor 30µF | M2 | Motor, Conveyor | S2 | Switch, Centrifugal |
| CB1 | Circuit Breaker, 10 Amp, Main | M3 | Motor, Cooling Fan | S3 | Switch, High Limit |
| CB2 | Circuit Breaker, 63 Amp, Heating Elements | OMC1 | Oven Control, Main | SSR1 | Solid State Relay, 50 Amp |
| CB3 | Circuit Breaker, 63 Amp, Heating Elements | OMC2 | Oven Control, Split Belt | SSR2 | Solid State Relay, 50 Amp |
| CB5 | Circuit Breaker, ½ Amp, Conveyor Motor | PB | Power Block | SSR3 | Solid State Relay, 50 Amp |
| CB6 | Circuit Breaker, ½ Amp, Conveyor Motor | PL1 | Push Lock, 1-3 Elements | SSR4 | Solid State Relay, 50 Amp |
| CS | Current Sensor | PL2 | Push Lock, 4-6 Elements | TC | Thermocouple |
| H1-H3 | Heating Element, 208 or 240 VAC, 4500 W | PS | Power Supply | TS2 | Terminal Strip |
| H4-H6 | Heating Element, 208 or 240 VAC, 4500 W | RD-Red | | GY-Gray | |

X3F-2440
X3F-3240

208 VAC 3 PH 60 Hz
XD-9130F-208/240-4500-6
Right Side
08/15/2016

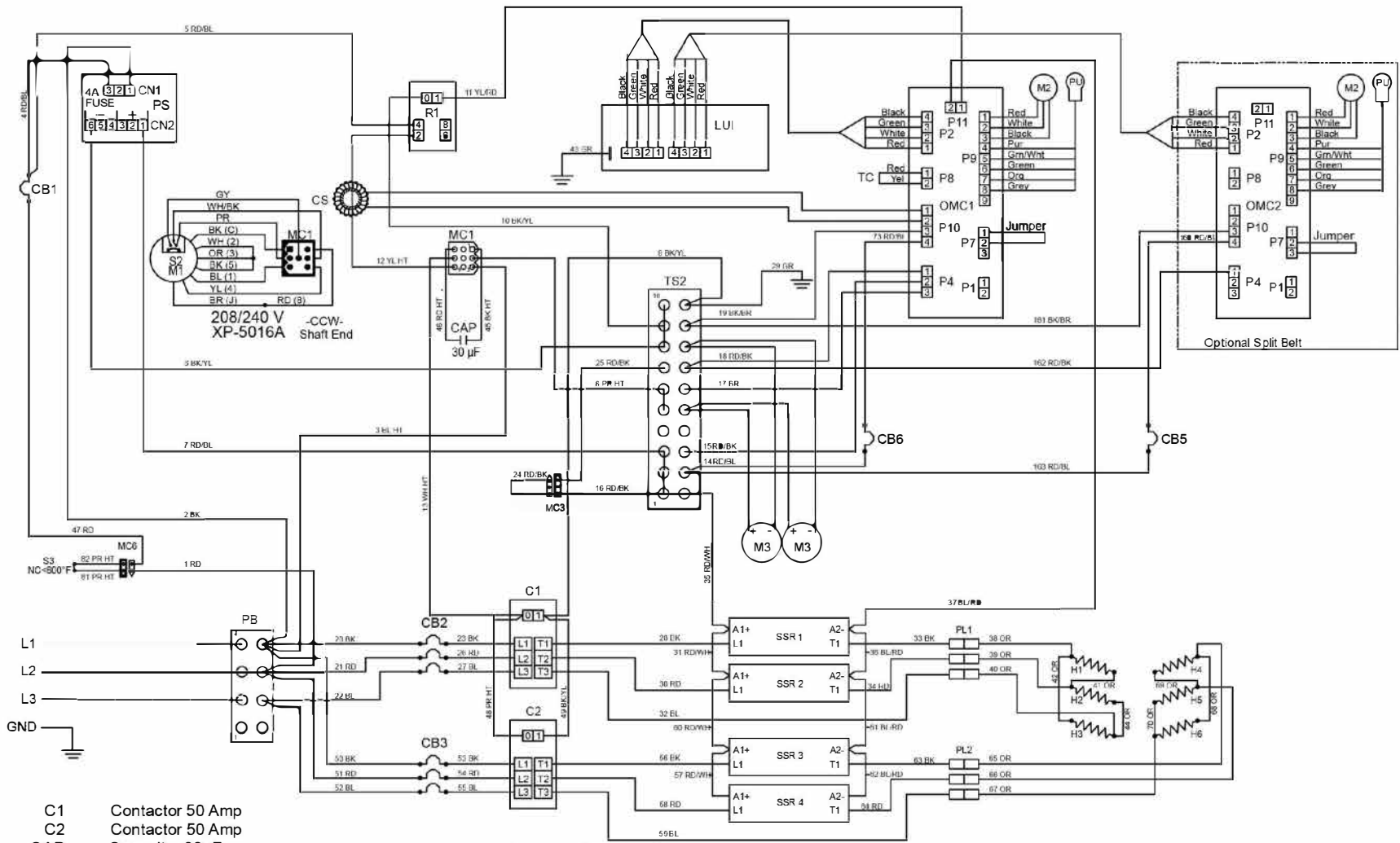

- | | | | | | |
|--------|---|--------------|--------------------------|----------|---------------------------|
| C1 | Contactors 50 Amp | M1 | Motor, Oven Fan | R1 | Oven Fan Motor Relay |
| C2 | Contactors 50 Amp | M2 | Motor, Conveyor | S2 | Switch, Centrifugal |
| CAP | Capacitor 30µF | M3 | Motor, Cooling Fan | S3 | Switch, High Limit |
| CB1 | Circuit Breaker, 10 Amp, Main | OMC1 | Oven Control, Main | SSR1 | Solid State Relay, 50 Amp |
| CB2 | Circuit Breaker, 63 Amp, Heating Elements | OMC2 | Oven Control, Split Belt | SSR2 | Solid State Relay, 50 Amp |
| CB3 | Circuit Breaker, 63 Amp, Heating Elements | PB | Power Block | SSR3 | Solid State Relay, 50 Amp |
| CB5 | Circuit Breaker, ½ Amp, Conveyor Motor | PL1 | Push Lock, 1-3 Elements | SSR4 | Solid State Relay, 50 Amp |
| CB6 | Circuit Breaker, ½ Amp, Conveyor Motor | PS | Power Supply | TC | Thermocouple |
| CS | Current Sensor | PU | Pick-Up | TS2 | Terminal Strip |
| H1-H3 | Heating Element, 208 or 240 VAC, 5300 W | | | | |
| H4-H6 | Heating Element, 208 or 240 VAC, 5300 W | | | | |
| LUI | Large User Interface | | | | |
| RD-Red | BK-Black | BL-Blue | BR-Brown | GR-Green | YL-Yellow |
| | PR-Purple | HT-High Temp | OR-Orange | WH-White | GY-Gray |

X3F-3255
X3F-3855

208 VAC 3 PH 60 Hz
XD-9130F-208/240-5300-6
Right Side
08/15/2016

Technical Support US: 888-443-2751



Technical Support INTL: 316-943-2751

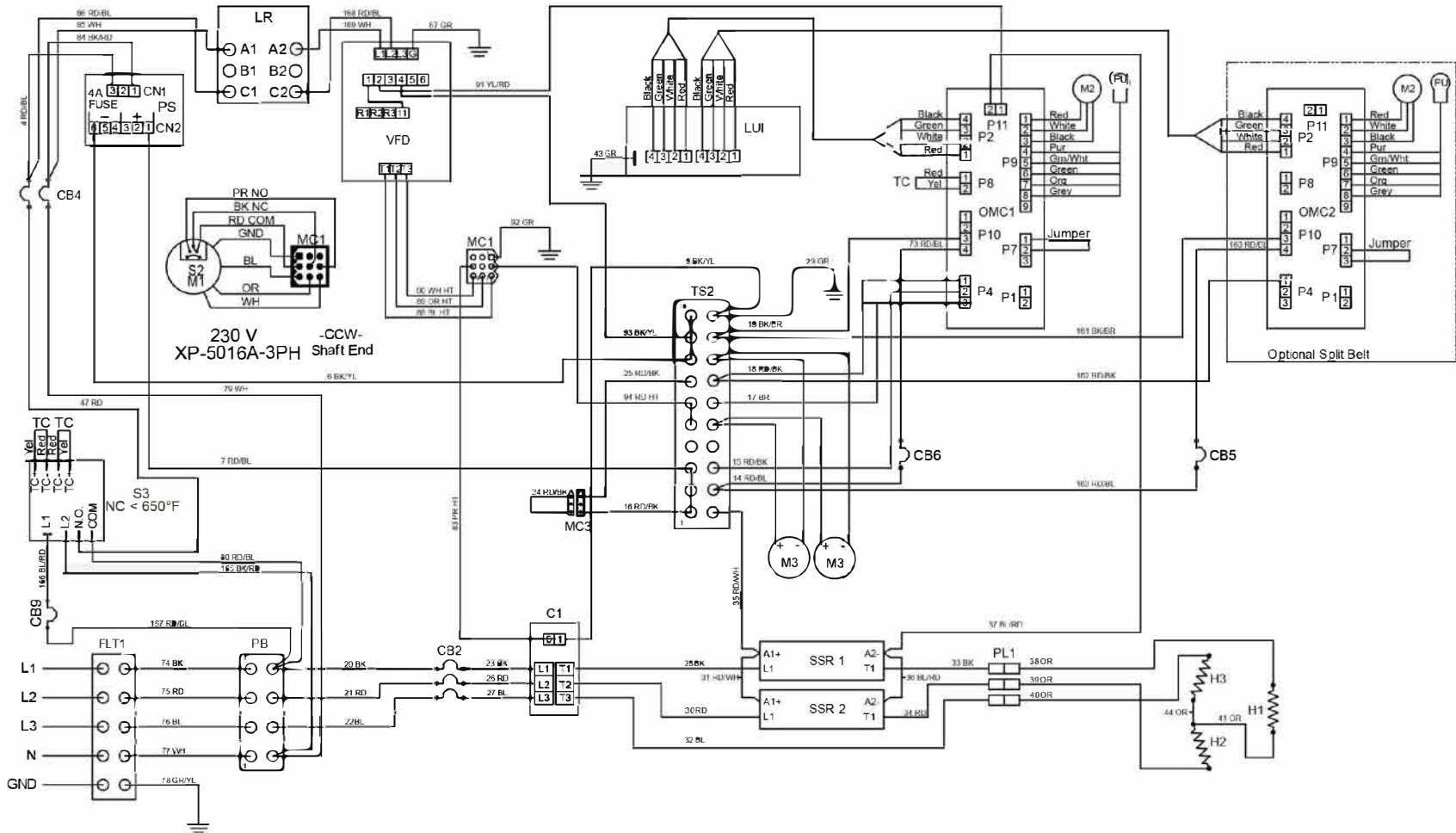

- | | | | | | |
|-------|---|------|----------------------------|------|---------------------------|
| C1 | Contactor, 30 Amp | LR | Line Reactor, 5% Impedance | PU | Pick-Up |
| CB2 | Circuit Breaker, 63 Amp, Heating Elements | M1 | Motor, Oven Fan | S2 | Switch, Centrifugal |
| CB4 | Circuit Breaker, 10 Amp, Main | M2 | Motor, Conveyor | S3 | Switch, High Limit |
| CB5 | Circuit Breaker, 1/2 Amp, Conveyor Motor | M3 | Motor, Cooling Fan | SSR1 | Solid State Relay, 30 Amp |
| CB6 | Circuit Breaker, 1/2 Amp, Conveyor Motor | OMC1 | Oven Control, Main | SSR2 | Solid State Relay, 30 Amp |
| CB9 | Circuit Breaker, 1/2 Amp, High Limit | OMC2 | Oven Control, Split Belt | TC | Thermocouple |
| CS | Current Sensor | PB | Power Block | TS2 | Terminal Strip |
| FLT1 | Filter, Control Voltage | PL1 | Push Lock, 1-3 Elements | VFD | Variable Frequency Drive |
| H1-H3 | Heating Element, 240 VAC, 5300 W | PS | Power Supply | | |
| LUI | Large User Interface | | | | |
- RD-Red BK-Black BL-Blue BR-Brown GR-Green YL-Yellow PR-Purple HT-High Temp OR-Orange WH-White GY-Gray

X3F-1832

380 VAC 3 PH 50 Hz
 XD-9130F-380-5300-3
 Right Side
 08/15/2016

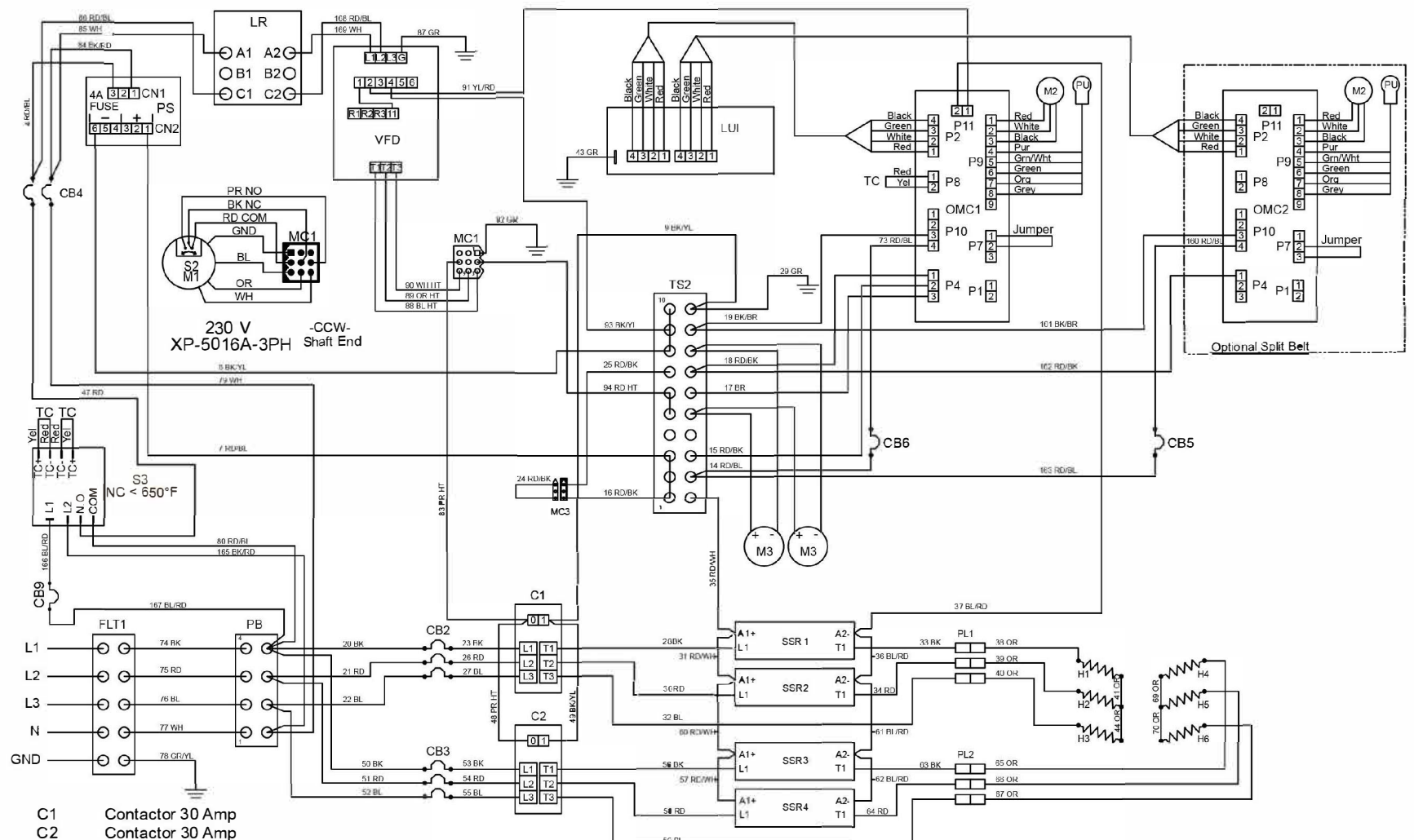

- C1 Contactor 30 Amp
- C2 Contactor 30 Amp
- CB2 Circuit Breaker, 63 Amp, Heating Elements
- CB3 Circuit Breaker, 63 Amp, Heating Elements
- CB4 Circuit Breaker, 10 Amp, Main
- CB5 Circuit Breaker, 1/2 Amp, Conveyor Motor
- CB6 Circuit Breaker, 1/2 Amp, Conveyor Motor
- CB9 Circuit Breaker, 1/2 Amp, High Limit
- FLT1 Filter, Control Voltage
- H1-H3 Heating Element, 240 VAC, 4500 W
- H4-H6 Heating Element, 240 VAC, 4500 W
- LUI Large User Interface
- RD-Red BK-Black BL-Blue BR-Brown GR-Green YL-Yellow

- LR Line Reactor, 5% Impedance
- M1 Motor, Oven Fan
- M2 Motor, Conveyor
- M3 Motor, Cooling Fan
- OMC1 Oven Control, Main
- OMC2 Oven Control, Split Belt
- PB Power Block
- PL1 Push Lock, 1-3 Elements
- PL2 Push Lock, 4-6 Elements
- PS Power Supply
- PR-Purple HT-High Temp OR-Orange WH-White GY-Gray

- PU Pick-Up
- S2 Switch, Centrifugal
- S3 Switch, High Limit
- SSR1 Solid State Relay, 30 Amp
- SSR2 Solid State Relay, 30 Amp
- SSR3 Solid State Relay, 30 Amp
- SSR4 Solid State Relay, 30 Amp
- TC Thermocouple
- TS2 Terminal Strip
- VFD Variable Frequency Drive

X3F-2440
 X3F-3240

 380 VAC 3 PH 50 Hz
 XD-9130F-380-4500-6
 Right Side
 08/15/2016

Technical Support US: 888-443-2751



Technical Support INTL: 316-943-2751

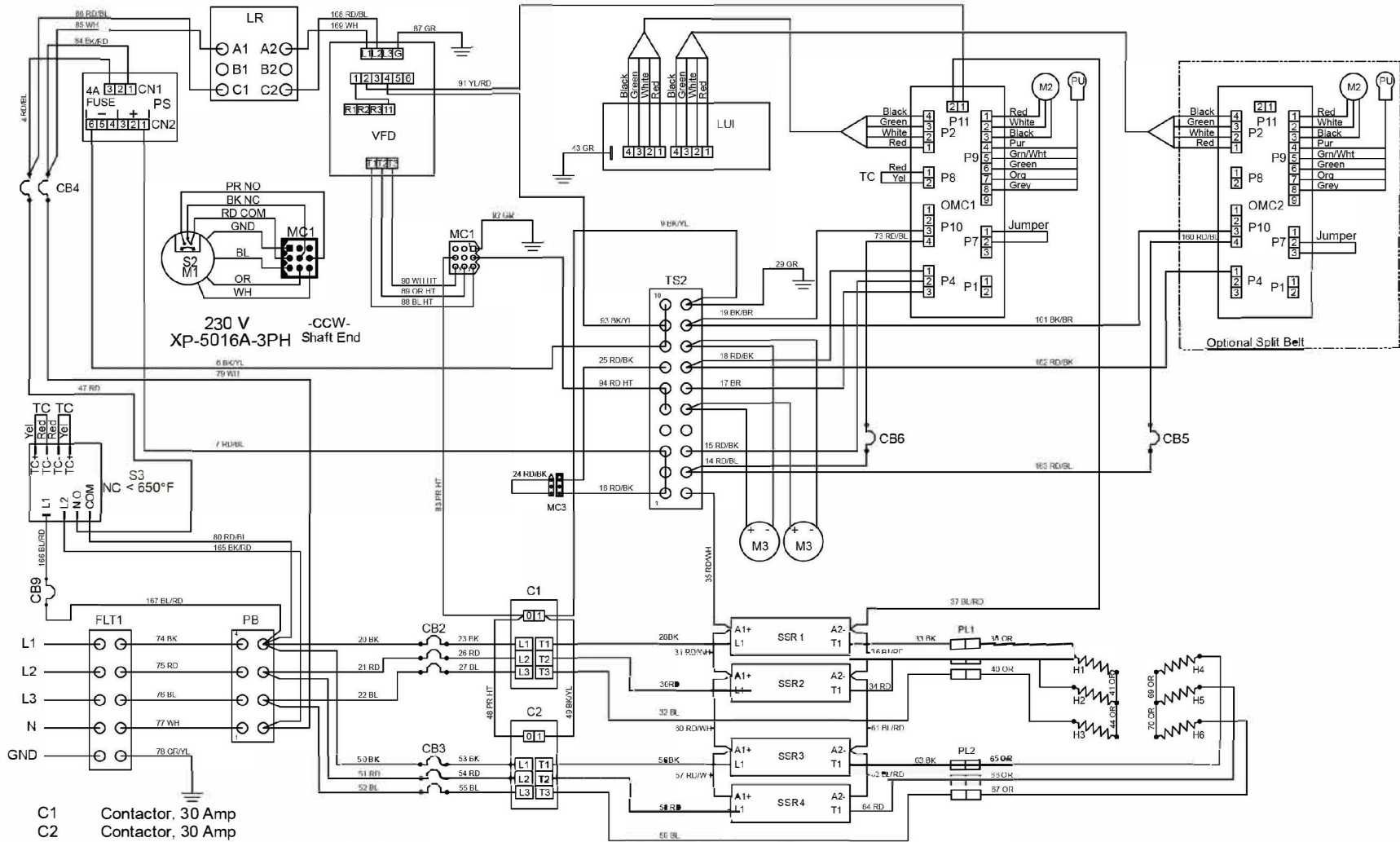

- | | | | | | |
|--------|---|---------|----------------------------|-----------|---------------------------|
| C1 | Contactor, 30 Amp | LR | Line Reactor, 5% Impedance | PU | Pick-Up |
| C2 | Contactor, 30 Amp | M1 | Motor, Oven Fan | S2 | Switch, Centrifugal |
| CB2 | Circuit Breaker, 63 Amp, Heating Elements | M2 | Motor, Conveyor | S3 | Switch, High Limit |
| CB3 | Circuit Breaker, 63 Amp, Heating Elements | M3 | Motor, Cooling Fan | SSR1 | Solid State Relay, 30 Amp |
| CB4 | Circuit Breaker, 10 Amp, Main | OMC1 | Oven Control, Main | SSR2 | Solid State Relay, 30 Amp |
| CB5 | Circuit Breaker, 1/2 Amp, Conveyor Motor | OMC2 | Oven Control, Split Belt | SSR3 | Solid State Relay, 30 Amp |
| CB6 | Circuit Breaker, 1/2 Amp, Conveyor Motor | PB | Power Block | SSR4 | Solid State Relay, 30 Amp |
| CB9 | Circuit Breaker, 1/2 Amp, High Limit | PL1 | Push Lock, 1-3 Elements | TC | Thermocouple |
| FLT1 | Filter, Control Voltage | PL2 | Push Lock, 4-6 Elements | TS2 | Terminal Strip |
| H1-H3 | Heating Element, 240 VAC, 5300 W | PS | Power Supply | VFD | Variable Frequency Drive |
| H4-H6 | Heating Element, 240 VAC, 5300 W | PR | Purple | | |
| LUI | Large User Interface | HT | High Temp | | |
| RD-Red | BK-Black | BL-Blue | BR-Brown | GR-Green | YL-Yellow |
| | | | | OR-Orange | WH-White |
| | | | | | GY-Gray |

X3F-3255
X3F-3855

380 VAC 3 PH 50 Hz
XD-9130F-380-5300-6
Right Side
08/15/2016

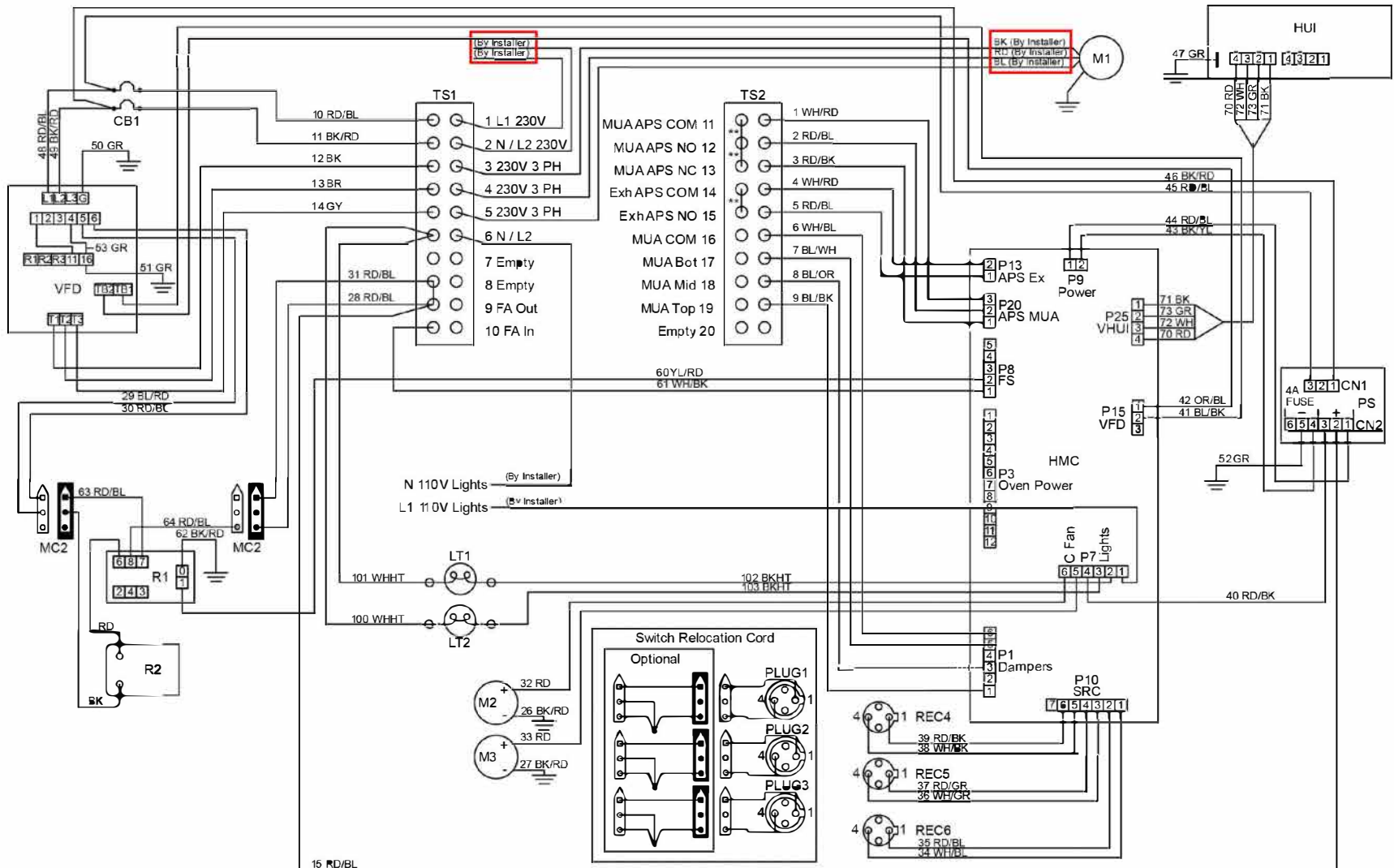

- | | | | | | |
|-----|-------------------------|------|-----------------------------------|------|---------------------------------|
| CB1 | Circuit Breaker, 10 Amp | M2 | Motor, Cooling Fan | REC5 | Receptacle, Switch, Middle Oven |
| HMC | Hood Machine Control | M3 | Motor, Cooling Fan | REC6 | Receptacle, Switch, Bottom Oven |
| HUI | Hood User Interface | PS | Power Supply | SRC | Switch Relocation Cord |
| LT1 | Lamp, 60W Bulb | R1 | Fire Suppression Relay | TS1 | Terminal Strip |
| LT2 | Lamp, 60W Bulb | R2 | Fire Suppression Time Delay Relay | TS2 | Terminal Strip |
| M1 | Motor, Exhaust Fan | REC4 | Receptacle, Switch, Top Oven | VFD | Variable Frequency Drive |

HD-9130E-ELE-VFD-S

RD-Red BK-Black BL-Blue BR-Brown GR-Green YL-Yellow PR-Purple HT-High Temp OR-Orange WH-White GY-Gray ** - Remove Jumpers for APS

08/15/2016

Technical Support US: 888-443-2751



Technical Support INTL: 316-943-2751

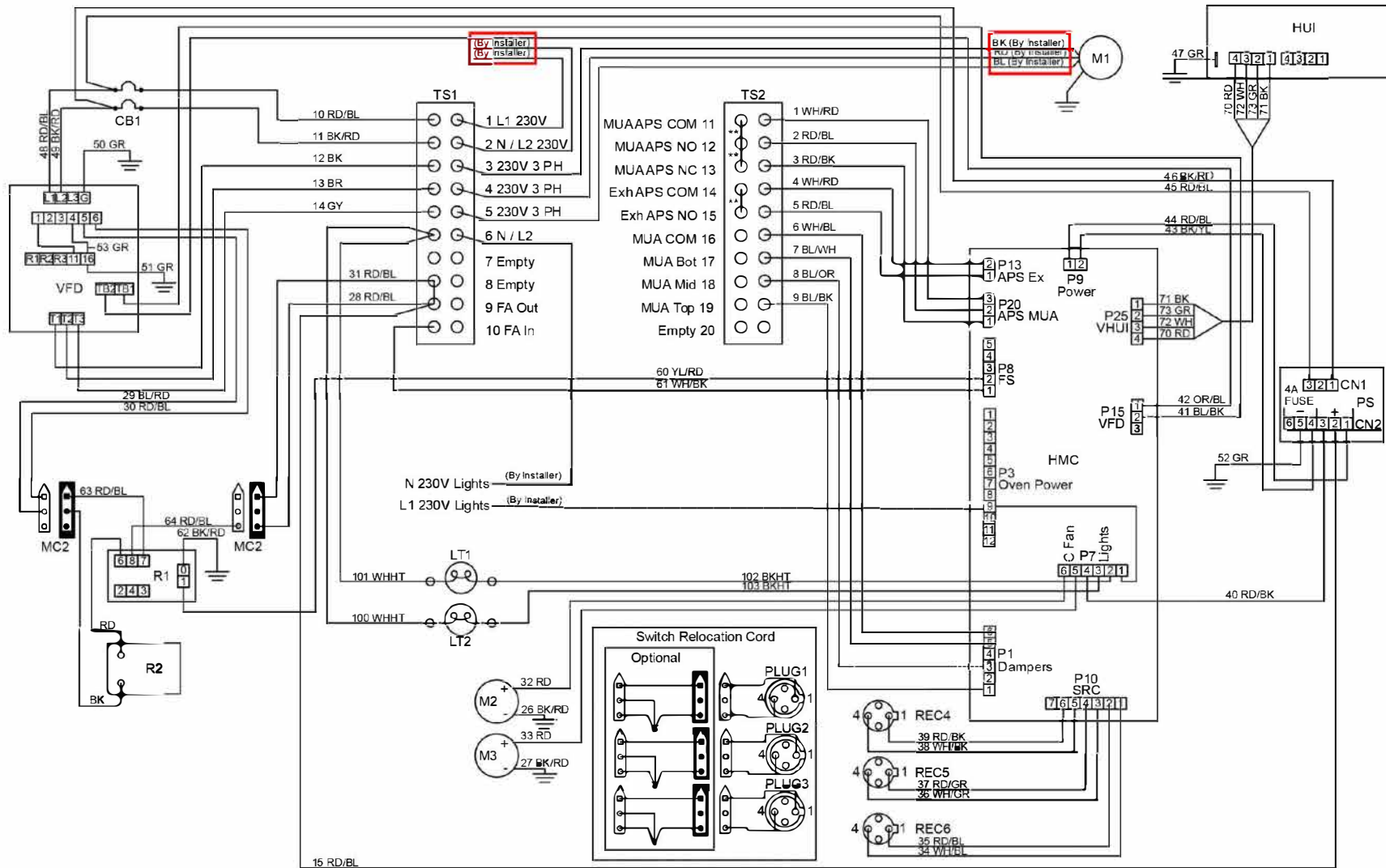

- | | | | | | |
|-----|-------------------------|------|-----------------------------------|------|---------------------------------|
| CB1 | Circuit Breaker, 10 Amp | M2 | Motor, Cooling Fan | REC5 | Receptacle, Switch, Middle Oven |
| HMC | Hood Machine Control | M3 | Motor, Cooling Fan | REC6 | Receptacle, Switch, Bottom Oven |
| HUI | Hood User Interface | PS | Power Supply | SRC | Switch Relocation Cord |
| LT1 | Lamp, 60W Bulb | R1 | Fire Suppression Relay | TS1 | Terminal Strip |
| LT2 | Lamp, 60W Bulb | R2 | Fire Suppression Time Delay Relay | TS2 | Terminal Strip |
| M1 | Motor, Exhaust Fan | REC4 | Receptacle, Switch, Top Oven | VFD | Variable Frequency Drive |

RD-Red BK-Black BL-Blue BR-Brown GR-Green YL-Yellow PR-Purple HT-High Temp OR-Orange WH-White GY-Gray ** - Remove Jumpers for APS

HD-9130E-ELE-VFD-W

08/15/2016

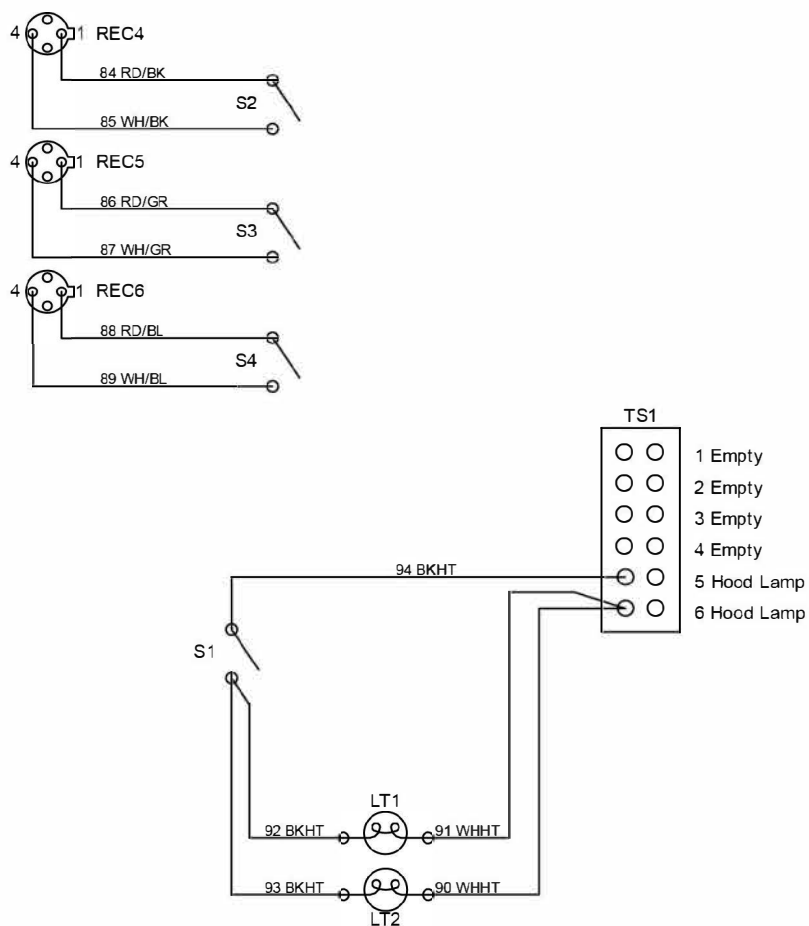

- LT1 Lamp, 60W Bulb
- LT2 Lamp, 60W Bulb
- REC4 Receptacle, Top Oven
- REC5 Receptacle, Middle Oven
- REC6 Receptacle, Bottom Oven
- S1 Switch, Light
- S2 Switch, Top Oven
- S3 Switch, Middle Oven
- S4 Switch, Bottom Oven
- TS1 Terminal Strip

RD-Red BK-Black BL-Blue GR-Green HT-High Temp WH-White HD-9130E-NV
07/26/2016

XLT Ovens
PO Box 9090
Wichita, Kansas 67277

US: 888-443-2751 FAX: 316-943-2769 INTL: 316-943-2751 WEB: www.xltovens.com