



XD 9006G
ADKDSWDHD
10/14/2015

Simple. Smart.



XLT Gas Oven & AVI Hood Parts & Service Manual



CAUTION

This appliance is for professional use by qualified personnel. This appliance must be installed by qualified persons in accordance with the regulations in force. This appliance must be installed with sufficient ventilation to prevent the occurrence of unacceptable concentrations of substances harmful to health in the room in which it is installed. This appliance needs an unobstructed flow of fresh air for satisfactory operation & must be installed in a suitably ventilated room in accordance with current regulations. This appliance should be serviced by qualified personnel at least every 12 months or sooner if heavy use is expected.

Electronic copies of this manual, Technical Specifications, Installation & Operation Manual, Architectural Drawings, & a list of International Authorized Distributors are available at: www.xltovens.com

For use with the following XLT Gas Oven Versions:

Australia (AE) D
Korea (K) D
Standard (S) D
World (W) D

For use with the following AVI Gas Hood Versions:

Standard (S) D
World (W) D



XLT Ovens
PO Box 9090
Wichita, Kansas 67277

US: 888-443-2751 FAX: 316-943-2769 INTL: 316-943-2751 WEB: www.xltovens.com



SAFETY DEPENDS ON YOU

**DANGER**

Improper installation, adjustment, alteration, service or maintenance can cause property damage, injury, or death. Read the installation, operating and maintenance instructions thoroughly before installing, using, or servicing this equipment.

- Post in a prominent location instructions to be followed in the event you smell gas. This information can be obtained by consulting your local gas supplier.

**DANGER****FOR YOUR SAFETY**

Do not store or use gasoline or other flammable liquids or vapors in the vicinity of this or any other appliance.

- In the event a gas odor is detected, shut off the gas at the main shutoff valve immediately. Contact your local Gas Company or supplier.
- Do not restrict the flow of combustion and/or ventilation air to the unit. Provide adequate clearance for operating, cleaning, maintaining the unit & adequate clearance for operating the gas shutoff valve when the unit is in the installed position.
- Keep the area free & clear of combustible material. DO NOT SPRAY AEROSOLS IN THE VICINITY OF THIS APPLIANCE WHILE IT IS IN OPERATION.
- Ovens are certified for installation on combustible floors.
- Electrical schematics are located inside the control box of the oven & and in this manual. Disconnect input power to the unit before performing any maintenance.
- This unit requires a ventilation hood. The installation must conform to local codes.
- This unit may be operated with either natural gas or liquid petroleum fuel as designated on the nameplate label located on the side of the unit.
- This unit must be operated by the same voltage, phase, & frequency of electrical power as designated on the nameplate label located on the side of the unit.
- Minimum clearances must be maintained from combustible & non-combustible construction materials.
- Follow all local codes when installing this unit.
- Follow all local codes to electrically ground the unit.
- Appliance is not to be cleaned with high pressure water.
- XLT ovens are certified for use in stacks of up to three (3) units of XLT products. Integration of other manufacturer's products into an oven stack is not recommended, & voids any warranties. XLT Ovens assumes no liability for mixed product applications.
- Failure to call XLT Customer Service at 1-888-443-2751 prior to contacting a repair company voids any & all warranties.
- PLEASE RETAIN THIS MANUAL FOR FUTURE REFERENCE.

XLT Ovens has spent millions of dollars designing and testing our products as well as developing Installation & Operation Manuals. These manuals are the most complete and easiest to understand in the industry. However, they are worthless if they are not followed.

We have witnessed store operators and building owners lose many thousands of dollars in lost revenue due to incorrect installations. We highly recommend you follow all instructions given in this manual as well as follow best practices in plumbing, electrical, and HVAC building codes.

Definitions & Symbols

A safety instruction (message) includes a “Safety Alert Symbol” & a signal word or phrase such as **DANGER**, **WARNING** or **CAUTION**. Each signal word has the following meaning:

**DANGER**

Indicates a potentially hazardous situation that, if not avoided, can result in serious injury or death.

**HIGH
VOLTAGE**

This symbol indicates high voltage. It calls your attention to items or operations that could be dangerous to you & other persons operating this equipment. Read the message & follow the instructions carefully.

**WARNING**

Indicates a potentially hazardous situation, that if not avoided, can result in cuts or being crushed. It calls your attention to items or operations that could be dangerous to you & other persons operating this equipment.

**CAUTION**

Indicates a potentially hazardous situation, that if not avoided, can result in minor to moderate injury or serious damage to the product. The situation described in the CAUTION may, if not avoided, lead to serious results. Important safety measures are described in CAUTION (as well as WARNING), so be sure to observe them.

**NOTE**

Notes indicate an area or subject of special merit, emphasizing either the product's capability or common errors in operation or maintenance.

**TIP**

Tips give a special instruction that can save time or provide other benefits while installing or using the product. The tip calls attention to an idea that may not be obvious to first-time users of the product.



Warranty - US and Canada

Rev D

Approval Date: 10/28/2013

XLT warrants gas ovens manufactured after April 1, 2009 and all electric ovens manufactured after April 1, 2011 to be free from any defect in material and workmanship under normal use for five (5) years from the date of original purchase by the end user, and further warrants main fan blades, conveyor shafts, and conveyor bearings for ten (10) years. XLT further warrants all ovens to be free from rust for ten (10) years from the date the equipment is originally purchased. XLT warrants AVI hoods to be free from any defect in material and workmanship under normal use for two (2) years from the date of original purchase by the end user purchaser. In the event of a part failure, XLT will furnish a replacement part and pay for all labor associated with the replacement of the part. If upon inspection XLT determines that the part is not defective, all incurred cost will be the responsibility of the end user purchaser. This warranty is extended to the original end user purchaser and is not transferable without prior written consent of XLT. Damages are limited to the original purchase price.

DUTIES OF THE OWNER:

- The owner must inspect the equipment and crates at time of receipt. Damage during shipment is to be immediately reported to the carrier and also to XLT
- The equipment must be installed and operated in accordance with the written instructions furnished with the unit
- This warranty shall not excuse the owner from properly maintaining the equipment in accordance with the written instructions furnished with the unit
- A copy of the "Initial Start-Up Checklist" must be filled out and returned to XLT when the unit is initially installed, and/or when the unit is removed and installed in another location
- The gas, electric, and HVAC utilities must be connected to the oven and installed by locally licensed contractors
- Failure to contact XLT Ovens prior to contacting a repair company for warranty work voids any and all warranties

WHAT IS NOT COVERED:

- Freight damage
- Overtime charges
- Any part that becomes defective because of utility services (power surges, high or low voltages, high or low gas pressure or volume, contaminated fuel, or improper utility connections)
- Any part that becomes defective because of moisture and/or other contaminants
- Conveyor belts
- Filters
- Exhaust Fans
- Light Bulbs
- Normal maintenance or adjustments
- This warranty shall not apply if the equipment or any part is damaged as a result of accident, casualty, alteration, misuse, abuse, improper cleaning, improper installation, improper operation, natural disasters, or man-made disasters

CLAIMS HANDLED AS FOLLOWS:

Should any such defect be discovered, XLT must be notified. Upon notification, XLT will arrange for necessary repairs to be made by an authorized service agent. Denial of services upon the arrival of an authorized service agent will release XLT of any and all warranty obligations.

7781 W Kellogg Drive 67209-2003 • PO Box 8080 67277-0080 • Wichita, Kansas
Voice (318) 643-2751 • (888) 443-2751 • Fax (318) 643-2789
www.xltovens.com





Warranty - International

Rev F

Approval Date: 07/01/2014

When purchased through an Authorized International Distributor, XLT warrants its products manufactured after July 1, 2014 to be free from any defect in material and workmanship under normal use. The Authorized International Distributor will repair XLT products during the warranty period. This warranty is extended to the original end user purchaser and is not transferable without prior written consent of the Authorized International Distributor. Damages are limited to the original purchase price. Products purchased by any other means other than an Authorized International Distributor will have no warranty. This warranty applies to areas outside the 50 United States of America.

DUTIES OF THE OWNER:

- The owner must inspect the equipment and crates at time of receipt. Damage during shipment is to be immediately reported to the carrier and also to the Authorized International Distributor.
- The equipment must be operated in accordance with the written instructions furnished with the unit.
- This warranty is not valid unless equipment is installed, started, and demonstrated under the supervision of the Authorized International Distributor.
- This warranty shall not excuse the owner from properly maintaining the equipment in accordance with the written instructions furnished with the unit.
- A copy of the "Initial Start-Up Checklist" must be filled out and returned to the Authorized International Distributor when the unit is initially installed, and/or when the unit is removed and installed in another location.
- The gas, electric, and HVAC utilities must be connected to the equipment and installed by locally licensed contractors.
- The Authorized International Distributor must be contacted for service. Failure to contact the Authorized International Distributor prior to contacting a repair company for warranty work voids any and all warranties.

WHAT IS COVERED (Subject to local market conditions):

- 2 year labor – Extensions may be available and charges may apply
- 5 year parts – Extensions may be available and charges may apply
- 5 years parts and labor on: oven fan blade, structural welds, conveyor shafts, conveyor bearings, rusted materials in ovens

WHAT IS NOT COVERED (Subject to local market conditions):

- Freight damage
- Any part that becomes defective because of utility services (power surges, high or low voltages, high or low gas pressure or volume, contaminated fuel, or improper utility connections)
- Any part that becomes defective because of moisture and/or other contaminants
- Conveyor belts
- Filters
- Exhaust fans
- Light bulbs
- Rusted materials in hoods
- Normal maintenance or adjustments
- This warranty shall not apply if the equipment or any part is damaged as a result of accident, casualty, alteration, misuse, abuse, improper cleaning, use of caustic/acidic chemicals, improper installation, improper operation, natural disasters, or man-made disasters

CLAIMS HANDLED AS FOLLOWS:

Should any such defect be discovered, the Authorized International Distributor must be notified. Upon notification, the Authorized International Distributor will arrange for necessary repairs.

7781 W Kellogg Drive 67208-2003 • PO Box 8080 67277-0080 • Wichita, Kansas
Voice (316) 843-2751 • (888) 443-2751 • Fax (316) 843-2789
www.xltovens.com



This manual, which contains an illustrated parts breakdown, has been prepared as an aid in understanding how the unit operates, how to diagnose problems, and order parts for the equipment. All of the parts, listed in the parts breakdown, are manufactured with the same precision as the original equipment.

XLT parts and service providers are available worldwide. There are authorized service providers located in the principle cities of the United States. There are also authorized Distributors located throughout the world.

The Theory of Operation section describes how the unit operates. An understanding of normal operation will greatly aid diagnosis and troubleshooting. The Troubleshooting section asks simple yes or no questions. The next question or statement entirely depends upon the previous answer. It will lead to the solution of a problem in the most efficient way. The illustrated parts section identifies the various sub-assemblies and detailed parts which make up the equipment, as well as the part number. An explanation of how to order parts is included.

This manual is designed to supplement the Installation & Operation Manual provided with the unit when new. Please refer to it for descriptions, dimensions, weights, electrical requirements, maintenance schedules, and certifications.

XLT Ovens wants you to be totally satisfied with every aspect of owning & using your oven & hood. Your feedback, both positive & negative, is very important to us as it helps us understand how to improve our products & our company. Our goal is to provide you with equipment that we can be proud to build & you can be proud to own.

To receive technical support for the oven or hood you purchased, XLT has qualified customer service personnel that can provide assistance on any type of XLT oven or hood equipment problem you may experience. Customer Service is available 24/7/365 at 888-443-2751 or visit www.xltovens.com.



DANGER

Repairs of all appliances & ventilation exhaust hoods should only be performed by a qualified professional who has read & understands these instructions & is familiar with proper safety precautions. Read this manual thoroughly before installing or servicing this equipment.

Save this Manual

This document is the property of the owner of this equipment.

XLT Ovens reserves the right to make changes in design & specifications, and/or make additions to or improvements to its product without imposing any obligations upon itself to install them in products previously manufactured.

All Right Hand & Left Hand designations in this manual are from the point of view as if standing directly in front of the glass sandwich door.

Warning & Safety Information..... 2
 Warranty..... 4
 General 6
 Oven Theory of Operation 8
 Hood Theory of Operation 14
 Oven Troubleshooting..... 17
 Hood Troubleshooting..... 18
 Oven Service Procedures..... 20
 Hood Service Procedures 26
 Oven Parts 29
 Hood Parts 53
 Oven Schematics 59
 Hood Schematics..... 68

For maintenance procedures, please refer to the XLT Installation & Operation Manual.

Revision History Table		
Revision	Comments	Date
F	Added R2 and S4 To Oven Theory of Operation and Updated Low Flame Bias	04/22/2015
G	Updated Hitachi X200 Parameters On Page 26	10/14/2015

When the Main Switch (S1) is turned on;

1. The Oven Fan Motor (M1) located in the Back Wall will run.
2. The Fan (M3) located on the Control Panel will run.
3. The Temperature Control (TC) will display both the actual and set-point temperatures.
4. The Conveyor Control (CC) will display the belt time.
5. The burner will ignite.
6. The conveyor belt will move.

The first part of the Theory of Operation explains how electrical power is delivered to the oven and initial sequences when the main operator switch is turned on. The remainder of the Theory of Operation section explains the function of components in alphabetical order. These components are also listed on the schematic.

- Line voltage for Standard Ovens is assumed to be 120 VAC, 60 Hz.
- Line voltage for World & Australian Ovens is assumed to be 230 VAC, 50 Hz.
- Line voltage for Korean Ovens is assumed to be 220 VAC, 60 Hz.

Power originates at the electrical connection on the wall. Line voltage is then carried into the oven through the power cord to the Terminal Strip (TS). The Neutral line is connected to the TS, and several jumpers are used to bridge along the TS to make connection points for multiple neutral lines from all components inside of the control box and Oven Fan Motor (M1). Line 1 is also connected to the TS. From the other side of the TS, a wire connects to Terminal T11 on the Cool Down Timer (R1), then continues to the High Limit Switch (S3 World & Australian only), through the Main Circuit Breaker (CB1), and stops at the Main Switch (S1). Unless the outlet on the wall has no power, the circuit just described has power at all times.

When S1 is turned on, line voltage will be carried through the switch simultaneously to four locations via two parallel circuits:

- Terminal T6 of the Cool Down Timer (R1)
- Terminal T5 of the Temperature Control (TC), via a Circuit Breaker (CB3)
- Transformer (XFMR)
- Power Supply (PS)

CAP - The Capacitor is physically mounted inside the Control Box but wired to the externally mounted Oven Fan Motor (M1). The Oven Fan Motor (M1) is a Permanent Split Capacitor (PSC) motor. PSC means a capacitor motor in which the starting capacitor and the auxiliary winding remain in the circuit for both starting and running. The CAP is a 30.0 uF +/- 6% 370VAC/B 50/60 Hz.

CB - Circuit Breakers are used to protect electrical components. The current value is printed on the front of all breakers. If a CB is tripped, eliminate the cause and press the front to reset.

CC - The Conveyor Control is supplied 24 VDC by the Power Supply (PS) via a Circuit Breaker (CB6 & CB7, optional) to Terminals 4 & 5. The belt time is displayed, and is user-adjusted by pressing and holding the up or down arrow button switches. See the Specification Sheet for minimum and maximum belt times. The motor speed is calculated based on the time that is entered. This time is translated to a RPM on the motor shaft depending on the size of the oven, the diameter of the sprocket, and the gear ratio of the gearbox. Once the motor is running, hall sensor inputs are fed back into the driver to determine the speed the motor is currently running at. This input goes into a PID algorithm to adjust the Pulse Width Modulation (PWM) output to control the speed to match the target speed that was calculated first. This PWM is adjusting the average voltage that the motor phases are seeing. As the average voltage goes up, the motor will speed up. As the average voltage drops, the motor speed will also drop. The maximum speed is based on a continuous 18-24V being supplied to the motor. The phasing of the controller is dependent on the hall sensor signals that are being returned. The controller reads the hall sensor position and from there knows which phase of the motor receives the 18-24V signal, which phase of the motor is the return and which phase of the motor is left open. As the motor spins, the hall sensors change, which dictate which phases are energized.

FLT 1 - Is an inline filter used in world ovens. The filter is placed in series with the Line voltage being supplied to the oven. The filter is used to reduce Electromagnetic Interference created by our equipment and back-feeding it into other appliances. EMI filters use capacitors to inhibit direct current while permitting alternating current. EMI filters also use inductors which redirect high voltages, and high frequencies by dissipating them to ground.

FS Optical - The Optical Sensor consists of a plastic housing and an flame detector mount with mirror. The optical sensor utilizes 24VDC which originates at the PS. The positive line is supplied via the TC1 terminal 1&2 and terminates at the connector for the sensor. The negative line is supplied via the TS #5 and terminates at the connector for the sensor. If the TC1 alarm would activate and open the circuit, the optical sensor will loose voltage and cause the oven to shut down burner functionality until alarm is closed. From the connector a brown wire sends a 6.75 μ A signal to the S1 Terminal of the IC. The minimum signal to maintain operation is .7 μ A.

When flame is present, the sensor visually looks at the Flicker rate and the UV characteristics of the flame. If either of these do not appear the sensor will not send current to the IC. The ignition will continue thru its process until lockout.

IC - The Ignition Control (IC) is powered by 24 VAC from the Transformer (XFMR). Incoming power will be interrupted by Centrifugal Switch (S2) mounted in the M1. When the IC receives power, it initiates a pre-purge lighting sequence. A red LED will blink once after about 2-3 seconds to give notification that the lighting sequence has started. After about 30 seconds, two events occur; 1) a high-voltage electrical signal will be sent to the Spark Igniter (SI) from the Spark Terminal, and 2) a 24 VAC signal will be generated across Terminals V1 & V2. The high voltage jumps across a gap in the SI creating a spark that can be heard, although the IC only produces this spark for four (4) seconds. One end of the Rectifier Plug is connected to Terminals V1 & V2 through a Circuit Breaker (CB5). The Rectifier Plug rectifies the 24 VAC to 24 VDC. The other

end of the Rectifier Plug is connected to Terminals 1 & 5 of the Main Valve (V1-V2). The V1-V2 valve will open, allowing fuel to flow into the burner. When the two simultaneous events occur, fuel flow and spark, ignition should occur. When flame is sensed by the FS, a DC signal is sent to Terminal S1 of the IC. The IC uses this DC current to prove ignition. A minimum of .7 μ A is required to maintain operation. If the Burner lights, the LED will not flash. If the Burner fails to light, the LED will flash three (3) times, repeatedly, and the IC will not attempt to re-light.

M1 – The Main Motor is a Permanent Split Capacitor (PSC), single phase, capacitor run motor and has an internal Centrifugal Switch (S2). The motor is dual voltage and reversible. The voltage to power the motor comes from the Cool Down Timer (R1) terminal T9 via CB2, and the motor will continue to operate for approximately 30 minutes after the main switch is turned off. There are no user serviceable parts in the motor, and the bearings are permanently lubricated.

M2 - The Conveyor Motor (M2) is a brushless 24 VDC gear motor. The motor receives current from the Conveyor Control (CC) through three (3) wires; 1) A black or “W” phase, 2) a white or “V” phase, and 3) a red or “U” phase. They carry between 18 to 24 VDC. Each wire is energized by the Conveyor Control (CC) in sequence to provide power to the individual stator coils which, in turn, provide motor rotation.

To determine the rotors position and send this position to the controller, three (3) Hall Effect switches are utilized. They read the rotational information from a disc mounted on the rotor assembly. This information is transmitted to the CC by three (3) wires; 1) an orange “U” phase pole signal output, 2) a green “V” phase pole signal output, and 3) a green/white “W” phase pole signal output. These are located in a plug that inserts into the CC. There are two (2) additional wires in this plug; 1) a purple wire which is supply voltage for the pole sensor, and 2) a gray wire that is ground.

The CC, using an internal logic circuit, energizes the stator coils to provide proper rotation and sets the energization (phase) timing to obtain the desired belt speed set on the controller. The motor drives an integral gear box that reduces the motor output speed to give the correct travel time to the conveyor belt. The integral gear box is sealed and permanently lubricated with grease. The ratio is 1/200. This motor contains no serviceable parts.

M3 - The Flow Path Pressure Generating (FPPG) fan supplies combustion air for the Burner. It is wired in parallel with M1 and will continue to operate for 30 minutes after S1 is turned off. A filter is provided to ensure clean air.

PS - The Power Supply rectifies line voltage to 24 VDC, and supplies power to the Conveyor Control (CC) and Flame Sense (FS). A 4 amp fuse is used to provide over current protection, which is mounted on the PS itself. There are no other fuses used anywhere else.

PU - The Pick-Up is physically mounted within the Conveyor Motor (M2) and utilizes hall effect technology integral to the M2 to monitor the rotation speed. The hall effect signal is transmitted to the CC, which converts it into linear travel speed of the conveyor.

R1 - R1 is a 30-minute off delay relay which functions as a cool down timer. Applying power to T6 activates the relay, which sends a voltage signal out from T9. When power is removed from

T6, voltage continues from T9 for 30 minutes. T9 supplies voltage to the Main Fan Motor (M1) through a Circuit Breaker (CB2), and also supplies voltage to the FPPG (M3) Fan. M1 and M3 are the only components that will continue to operate for 30 minutes after S1 is turned off. The off delay relay is a safety feature to allow the oven to cool down to room temperature, and to eliminate heat stress on the components of the oven.

R2 - Proving Relay (Australia). This is a relay that proves the Main Motor (M1) has come to a stop before the motor can be started. This is used to provide combustion air to the burner. Voltage from the XFMR travels through Proving Relay (R2) to Centrifugal Switch (S2) (which is closed) back to R2 to activate the relay. Once this happens R2 is held open by a jumper from terminal R2-B to terminal R2-9 until the S2 is cycled to the off position. If the burner fails to light or has a loss of flame then the Manual Reset (S4) must be triggered and wait for the main fan motor to come to a complete stop.

RP - The Rectifier Plug has an integrated full-wave bridge rectifier circuit. It converts 24 VAC from the Ignition Control (IC) into 22 VDC that is sent to the Multi-Valve (V1-V2).

S1 - The Main Switch is a SPST normally open switch, mounted on the front of the Control Box. Activating this switch applies voltage to Terminal T6 of the Cool-Down Timer (R1) and to the primary side of the Transformer (XFMR). When used with the optional AVI Hood System, a remote switch mounted in the front of the AVI Hood replaces it.

S2 - This Switch is a SPDT centrifugal switch physically mounted inside the Main Motor (M1). When M1 comes up to full speed, S2 closes and sends a 24 VAC signal to the Ignition Control (IC) and the Signal Conditioner (SC). It functions as a safety feature to prevent burner operation if the M1 fails to rotate.

S3 - High Limit Switch (World & Australia). This is a bi-metal, NC, SPST switch physically mounted in the side panel of the Bake Chamber. It's purpose is to provide fail safe operation. If the temperature of S3 exceeds 600°F, it opens and interrupts line voltage to all components except the Main Motor (M1).

S4 - This momentary switch is a SPST normally closed switch, mounted on the rear of the Control Box. Activating this switch this switch breaks the supply voltage to Terminal T11 of the Cool-Down Timer (R1) and cancels the 30 minute cool down cycle. This switch is only used for the Australian certified ovens to allow the user to reset the Proving Relay (R2) when there is a loss of flame. After this switch is activated you must wait 5 minutes or until the main fan motor has come to a complete stop.

SC - The Signal Conditioner is powered by 24 VAC from the Transformer (XFMR) via the Main Motor Centrifugal Switch (S2) and the Temperature Control (TC) on terminals 1 & 2. Incoming power will be interrupted by the Main Fan Motor if it stops rotating. The function of the SC is to convert a 4-20 mA signal from the TC to a 45-250 mA signal and then applies that signal to the Multi Valve (V3). This in turn modulates the valve to allow an appropriate amount of fuel to control temperature.

SI - The Spark Igniter consists of a copper-clad metal mounting plate, and an electrode encapsulated in ceramic insulation. The insulated electrodes has a 1/4" male spade welded to it. This spade connects to the Spark Terminal on the Ignition Control (IC) via a spark wire. The end of this rod is positioned near the burner tube in such away so as to create a small gap. When the high-voltage signal from the IC reaches the gap, it is forced to jump the gap resulting in a spark.

T/C - The thermocouple is a type K. It consists of two different conductors that produce a voltage proportional to a temperature difference between either end of the pair of conductors. The T/C is connected to Terminals 9 & 10 of the TC. The millivolt signal is used to display the actual temperature.

TC1/TC2 - The Temperature Control (TC) has line voltage applied to terminal T5, and neutral voltage applied to terminal T4. There are two displays; one for actual temperature and one for set-point temperature. Actual temperature is determined by the Thermocouple (T/C), connected to terminals 9 & 10, with T9 being the negative terminal and T10 being the positive terminal. The user determines the set-point temperature by pressing and holding the <UP> or <DOWN> arrow button switches. The TC sends a 4-20 mA (milliamp) signal to the Signal Conditioner (SC) depending upon the relationship between actual temperature and set-point temperature. An alarm relay exists between terminals 1 & 2, If the actual temperature achieves temperatures above set temperature the alarm circuit will open and not allow voltage to be supplied out to the FS. The Maximum Operating Temperature is set at the factory and cannot be field adjusted.

V1-V2 & V3- The Multi-Valve assembly has three (3) Gas Valves. The Main Valves (V1-V2) operate in series, and are wired in series via the Rectifier Plug. The Rectifier Plug rectifies 24 VAC from the Ignition Control (IC) to 22 VDC. V1-V2 are solenoid valves and are open continuously during burner operation, regardless of either actual or set-point temperature values. V3 is a modulating valve, and is controlled by a variable electrical signal from the Signal Conditioner (SC). There are two (2) fuel pressure testing ports; one for incoming pressure, and one for both high-bias and low-bias pressure. The upper port is used for incoming pressure, while the lower port is used for high- and low-bias pressure. There are two (2) hex adjusting nuts; an 8mm nut for adjusting high-bias pressure, and a 5mm nut for adjusting low-bias pressure.

XFMR- The Transformer steps down line voltage to 24 VAC. It supplies power to the Signal Conditioner (SC), Ignition Control (IC), and the Centrifugal Switch (S2). One terminal on the secondary side is connected to chassis ground by a green wire. The XFMR is ON whenever the Main Switch (S1) is on, and is independent of the Cool Down Timer (R1). Note: The XFMR is equipped with an integrated circuit breaker for standalone protection.

This page intentionally left blank.

When any one of, or all of, the Hood Operator Switches (S2, S3, & S4) are turned on;

1. The Exhaust Fan Motor (M1) located on the roof will run.
2. The Variable Frequency Drive (VFD) will display a set value. The values are preset from the factory and can be referenced in the I&O manual.
3. The ovens associated with the corresponding switches will turn on.

The first part of the Theory of Operation explains how electrical power is delivered to the hood and initial sequences when the main operator switch is turned on. The remainder of the Theory of Operation section explains the function of components in alphabetical order. These components are also listed on the schematic.

- Line voltage for Standard Hoods is assumed to be 208/240 VAC, 60 Hz. (1) Phase
- Line voltage for World & Australian Hoods is assumed to be 230 VAC, 50 Hz. (1) Phase

Power for the hood originates at building's electrical service panel. A total of four (4) circuits are required; (1) is a single phase high voltage circuit for VFD/Fan circuit that connects to TS 1 terminals 1 & 2, and (2) (2, 3, and 4) are single phase low voltage minimum 20A circuits for each oven that connect to terminals 7-8, 9-10, and 11-12 which are located on TS 1. Lights, fire suppression, and cooling fans piggyback off the the top oven power terminals 7-8 on TS 1.

Switches mounted on the hood control lighting, VFD activation, Make Up Air (MUA) activation and oven function. When S1 is activated voltage will be carried to the lights turning them on. When XLT Ovens are installed with an AVI Hood, the Switch Relocation Cord (SRC) effectively eliminates the Main Switch located on the oven and transfers control to S2-S4 switches on the hood. When S2-S4 switches are activated a contact on the back of the switch will allow a low voltage signal to be sent to the VFD signaling it to turn on to a set frequency, at the same time when S2 is activated another contact switch will allow line voltage to be carried through the Switch Relocation Cord (SRC) to the oven activating it. When S2-S4 are activated the MUA will turn on when the VFD gets above 10 Hz. The VFD has a built in power supply that is wired to R1 then back to terminal 1 on the VFD this puts the VFD in run mode so whenever a power loss is sensed the VFD will start back up in run Mode once power is restored. The NO switch in the fire alarm system in the building needs to be connected to TS 2 terminals 13 & 14. When the alarm is activated it will supply line voltage to R3 making the relay switch from NC to NO, disabling all three ovens, shutting down MUA and disabling the lights and cooling fan at the same time. When line voltage is supplied to the coil of R3 it also is supplied to R2, switching it from NC to NO activating the exhaust fan to run full speed.

AL - The Alarm and Buzzer is the red light located on the switch plate next to the on/off switches. The VFD triggers the alarm signal when a fault has occurred (such as a malfunction in the exhaust fan). When the fault is cleared the alarm signal becomes inactive. The alarm is only available with the VFD.

CB - Circuit Breakers are used to protect electrical components. If a CB is tripped, eliminate the cause and press the front to reset.

LT1 & LT2 - These are standard light bulbs, and should illuminate when the contacts of S1 are closed.

LT3 – This is a green LED indicator that is driven by the VFD via R1 to indicate that the fan is operating at 10Hz or above.

M1 – The Exhaust Fan Motor is a 3-phase, direct drive motor. In normal operation, it is powered by the VFD and it's RPM will vary as the frequency from the VFD varies. There are no user serviceable parts in the motor, and the bearings are permanently lubricated.

M2 & M3 – The Cooling Fan Motor is a 1-phase, direct drive motor. In normal operation, it is powered through R1. These fans are used to keep the control box for the hood cool. There are no user serviceable parts in the motor, and the bearings are permanently lubricated.

PLUG 1, 2, & 3 – These are circular electrical plugs on one end of the Switch Relocation Cord (SRC). The Plugs connect to Receptacles 1, 2, & 3 on the bottom of the Hood Junction Box. The other end of the SRC plugs into the oven wire harness, and eliminates the operator switch supplied in the oven. Conversely, when the operator switch on the hood is turned off, the corresponding oven is turned off as well.

R1 – Is a DPDT relay, which is a electrically operated switch. It uses an electromagnet to operate a switching mechanism. 24vdc voltage is supplied from the VFD and current flows through a coil in the relay, causing the contacts in the relay to close. This will complete a circuit for the M2 & M3 to activate and turn on. R1 also switches to closed to send an activation signal back to the MUA via terminals 15-16 on TS2.

R2 – Is a SPDT relay, which is an electrically operated switch. It uses an electromagnet to operate a switching mechanism. No line voltage is supplied from TS2 via R3 until the fire alarm is activated. Once fire alarm is activated voltage is supplied to the coil in the relay, causing the contacts in the relay to close. This will complete a circuit between terminal 1 and 5 on the VFD activating the exhaust fan to run full speed.

R3 – Is a SPDT relay, which is a electrically operated switch. It uses an electromagnet to operate a switching mechanism. No line voltage is supplied from TS2 to R3 until the fire alarm is activated. Once fire alarm is activated voltage is supplied to the coil in the relay, causing the contacts in the relay to switch from NC to NO. This will interrupt the circuit in the relay supplying voltage to the lights, the ovens and the cooling fans, the MUA will shut down and the exhaust fan will run at full speed.

R4,& R5- These are SPDT relays, which are electrically operated switches. They use an electromagnet to operate a switching mechanism. When S3, or S4 are activated line voltage is supplied to the coil of corresponding relay switching it from NC to NO. This completes a circuit for a damper that could be wired into 17- 20 on TS 2.

REC 1, 2, & 3– These are electrical receptacles, which supply line voltage for the ovens. Each receptacle should have a 20A dedicated breaker supplied from the buildings electrical panel. Line voltage to each receptacle is supplied via TS1 and R3. If fire alarm is activated R3 will disrupt line voltage being supplied to receptacle shutting the oven off.

REC 4, 5, & 6– These are circular electrical receptacles mounted on the bottom of the Hood Junction Box. The Switch Relocation Cord (SRC) connects into these and to main switch in the corresponding oven. This deactivates the switch on the oven and relocates the operation of it onto the front of the hood.

S1 - This SPST (NO) switch is located on the front of the hood and controls the lights.

S2, 3, & 4 - These DPST (NO) switches are located on the front of the hood and control the ovens, as well as initiating and sequencing the operation of the VFD and damper circuits.

Line voltage is continuously applied to pin 1 of REC 4, 5, & 6, which is connected by a wire to a contact in S2, 3, & 4. This is shown on the schematic as the lower RH connection point of S2, 3, & 4. When the switch contacts are closed, shown on the upper LH connection point on the schematic, power is applied to pin 2 of the receptacles, as well as terminal A of 4, & 5. In essence, S2, 3, & 4 replace the switches on the ovens, and also energize the coils of R1, 4, & 5, which closes the relay contacts and sends a control signal to dampers or Make-up Air System.

The other set of contacts, shown as the upper set on the schematic, connect terminal 24 of the VFD and terminals 4, 3, & 2 respectively. The VFD generates it's own 24 VDC signal voltage, and the switches serve as inputs to the VFD. The VFD outputs user-selected frequencies depending upon the combination of switches that are closed.

TS 1, 2, & 3- These are terminal strips, which serves as a connection point for wires.

VFD - The Variable Frequency Drive (VFD) converts the AC supply voltage to DC and then converts the DC to a suitable three-phase frequency source for M1. Incoming power connects to terminals L1 & L3. M1 connects to terminals T1, T2, & T3 through TS1. The VFD generates it's own 24 VDC control voltage on terminal P24. S2, S3, & S4 serve as user-controlled inputs and connect terminals 1, 2, & 3 to terminal P24. User inputs include a <RUN> and <STOP/RESET> buttons, as well as <UP> and <DOWN> arrow buttons. A complete manual can be found at www.xltovens.com.

Mechanical Function

If your oven does not function properly, please verify the following conditions:

1. Verify that the power cord to the oven is connected and/or plugged in if equipped with a plug and receptacle.
2. Check all circuit breakers on the oven control panel to ensure they have not been tripped.
3. Check to see that the circuit breakers in the building electrical service panel have not been tripped or turned off.
4. Check the Manual gas valve to verify that it is turned on completely. The handle on the valve should be parallel with the gas piping when the valve is turned on, and the handle will be perpendicular with the gas piping when the valve is turned off. Also remember that anytime the gas hose has been disconnected it will take time to purge the air from the gas train.
5. Verify that oven is supplied with gas by disengaging and reengaging the quick-disconnect fitting on the gas hose.
6. Check to see that the oven is fully assembled. All of the fingers must be properly installed. Incorrect or incomplete finger placement can cause a “windy” condition that can cause the burner not to light.
7. Gas line size and pressure must be adequate to support total BTU requirements with all appliances in store turned *on*. Refer to the “Oven Gas Requirements” section of this manual.
8. (Australia Only) In the case of the oven not lighting properly. Turn off the oven and press and hold the manual reset switch on the back of the control box for five seconds. Wait approximately 30 seconds or until the fan stops spinning and turn the oven back on.

If your oven still does not function properly, XLT has qualified customer service personnel that can provide assistance on any type of XLT oven problem you may experience. Customer Service is available 24/7/365 at 888-443-2751, or visit www.xltovens.com.

Initial troubleshooting of the hood:

1. Make sure that the RUN lamp and POWER lamp on the VFD are lit.
2. Check to see that the green fan LED on the switch plate is on.
3. Check the actual frequency of the VFD controller. To access the actual frequency, press and hold the <FUNC> button until the Display Mode shows D001. Release the button, and then press one (1) more time. This will show actual operating parameters, not programmed parameters.
4. Check to see that the breaker in the service panel is not tripped.
5. Remove panel covering VFD to check and see if the circuit breaker is tripped.
6. Make sure the Switch Relocation Cords (SRC) are properly installed to the oven(s).
7. Check to see that the grease filters are clean & installed properly.
8. Check to see if the exhaust fan is rotating in the correct rotation. To verify fan rotation, remove the lid on the exhaust fan. Visually inspect rotation in accordance with label on fan housing.

The VFD has internal diagnostics, and may show the following ERROR codes:

- E01-E04 Inverter output was short circuited
- E05 motor overload is detected by electronic thermal function
- E07 DC bus voltage exceeds a threshold
- E09 DC bus voltage is below a threshold
- E14 Ground fault detected between controller output and motor

If any of the above error codes are displayed, then follow these steps to clear them.

1. Check VFD display for error code and record it.
2. Clear error by pressing the <STOP RESET> button.
3. Press the <RUN> button to activate exhaust fan.
4. Normal operation resumes with no error codes.
5. If error codes return press the <STOP RESET> button.

If the corrective actions listed above do not correct the problem, then XLT has qualified customer service personnel that can provide assistance on any type of XLT Oven or AVI Hood problem you may experience. Customer Service is available at 888-443-2751 24/7/365, or visit www.xltovens.com. The website offers an interactive troubleshooting guide that can further assist in diagnosing problems.

For repairs or maintenance of the fire suppression system and components, contact the local Ansul dealer or XLT for assistance.

This page intentionally left blank.

Conveyor Control Programming Procedure



TIP

Read the entire instruction before programming.

Configuration Key Functions

< L > = Behind the <L> in XLT is a hidden button. This is used along with the up and down button to access the programming mode. Use this after each step to advance to the next parameter when programming.

△ UP = Increases the setting of the selected parameter.

▽ DOWN = Decrease the setting of the selected parameter.

1. Enter Programming Mode/Program the bake length

- Press the <L> button and both <UP> and <DOWN> button simultaneously to enter programming mode.
- 0055 will appear on screen, this is already set from factory
- Press the <UP> button until the desired belt length is displayed. Belt lengths will read as follows:

1832 = 0032

2440 = 0040

3240 = 0040

3255 = 0055

3270 = 0070

3855 = 0055

3870 = 0070

2. Program the Total Reduction Value - Press the <UP> button until the desired settings is reached. All ovens = 300.
3. Set Speed Trimming Value - Press the <DOWN> button until the display shows 0000.
4. Set Fast Bake Limit - Press the <UP> button until the display shows 1:30.
5. Set Slow Bake Limit - Press the <UP> button until the display shows 17:00.
6. Set Conveyor Motor Rotation - Press the <UP> OR <DOWN> buttons until the display shows 1 for right-to-left direction, or 2 for left-to-right belt direction.
7. Set Conveyor Control default to 556 (in/rev).
8. Save and Exit Programming Mode - Press the <L> button two (2) times to save and exit Programming Mode.

After leaving Program Mode, 1:30 run time will appear on the display. Press and hold the <UP> or <DOWN> buttons until desired run time appears.

Temperature Control Programming Procedure



TIP

Read the entire instruction before programming.

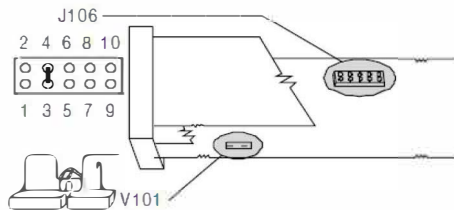

Figure 1.

Configuration Button Functions

<FUNC> = The new setting of the selected parameter is stored and the display advances to the next parameter. This is required between each parameter.

△ UP = Increases the setting of the selected parameter.

▽ DOWN = Decrease the setting of the selected parameter.

1. Open V101 switch for Basic/Advanced Configuration (Figure 1)

- Remove instrument from its case
- Open switch V101
- Verify that jumper J106, is configured as shown
- Re-insert the instrument back in its case

2. Basic Configurations

- Using the configuration buttons, scroll through parameter codes, changing them to match (Table 1)
- After P17 _._._. Will appear
- Using the configuration buttons scroll to 262 and press <FUNC> to enter Advanced Configurations

3. Advanced Configuration Procedure

- Using the configuration buttons scroll through parameter codes changing them to match (Table 2)

4. Close V101 switch after Basic/Advanced Configuration (Figure 1)

- Remove instrument from its case
- Close Switch V101
- Re-insert the instrument back in its case
- If Error 400 appears, press and hold △ and ▽ to clear

5. Operating Parameters Procedure (Table 3)

- On the first pass through change nnn to 3111 to unlock the advanced configuration
- Scroll through the parameter codes again and change the nnn to 5 this locks the advanced configuration
- Scroll through the parameter codes again and verify nnn in ON

Ser1	OFF
P1	5°C/22°F
P3	0
P4	315°C/600°F
P5	reU
P6	4-20
P9	AL1.P
P10	H.A.
P11	nonE
P16	0
P17	SfTA

Table 1

P18	norL
P19	norL
P24	reU
P25	OFF
P28	0
P29	0n
P30	0
P34	OFF
P36	tn.30
P37	0
P39	n0FL
P41	P.I.d.
P42	10.0
P43	Fn.SP
P44	0

Table 2

SP	260°C/500°F
SP2	0
nnn	3111/5
AL1	315°C/600°F
HSA1	0.1
Pb	5.0
ti	5.00
td	0.00
lP	30.0
rL	204°C/400°F
rH	310°C/590°F
Grd1	InF
Grd2	InF
OLH	100.00
toL	InF
mP	InF

Table 3

Multi-Valve Adjustment Procedure

Check Incoming Pressure:

- Loosen screw 1 full turn counter clockwise (Figure 1)
- Connect Manometer to this test port
- Turn main switch to on position and wait for burner to light (up to 30 seconds)
- Document incoming pressure on startup checklist. (If new installation)

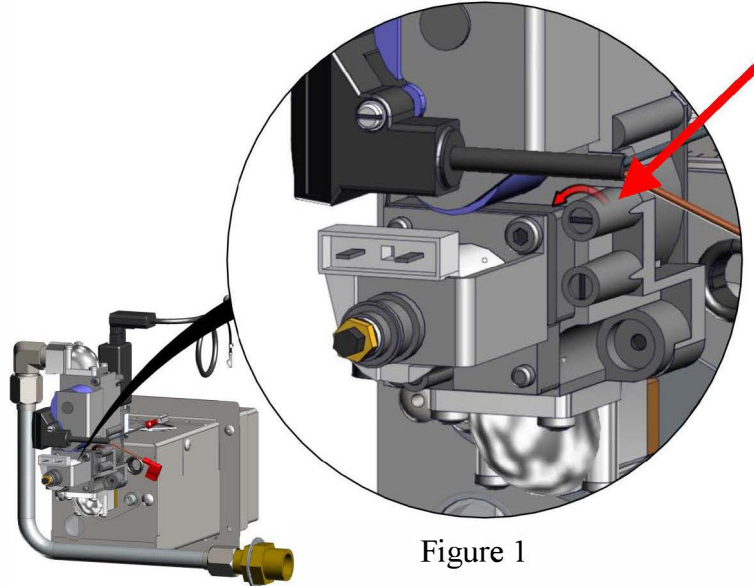

Figure 1

- Turn Main switch to the off position
- Disconnect Manometer
- Tighten screw clockwise until snug (Figure 2)

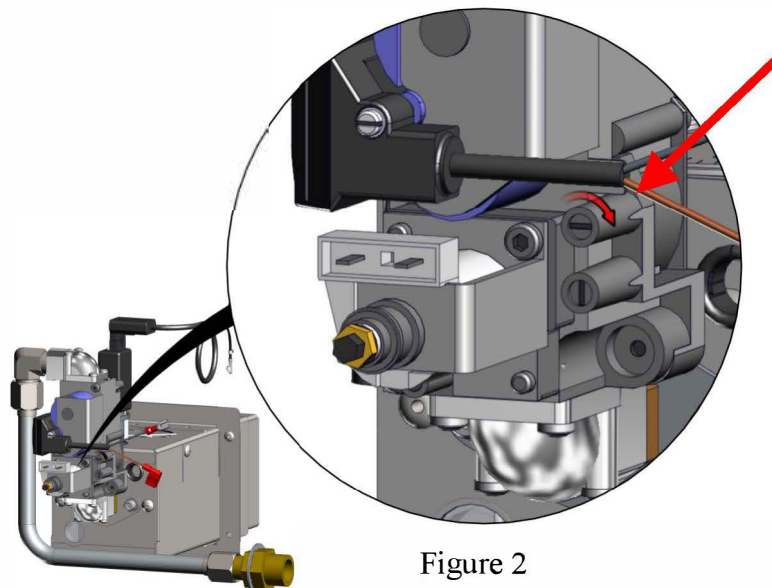

Figure 2

Multi-Valve Adjustment Procedure

Check High Bias Pressure:

- Loosen screw 1 full turn counter-clockwise (Figure 3)
- Connect Manometer to this test port
- Turn main switch to on position and wait for burner to light (up to 30 seconds)

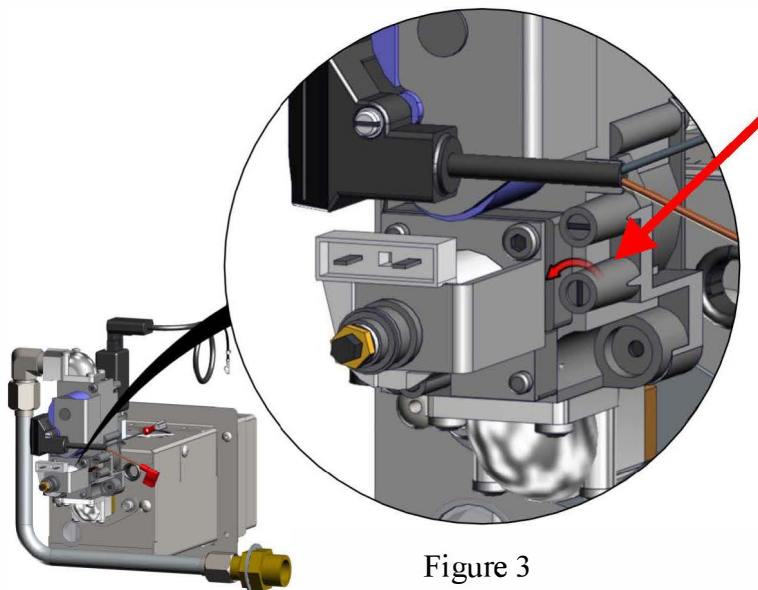

Figure 3

- Using an 8mm socket turn the High Flame Bias screw (Figure 4) until desired setting is achieved. Use chart on next page (Figure 5) for correct valve settings.

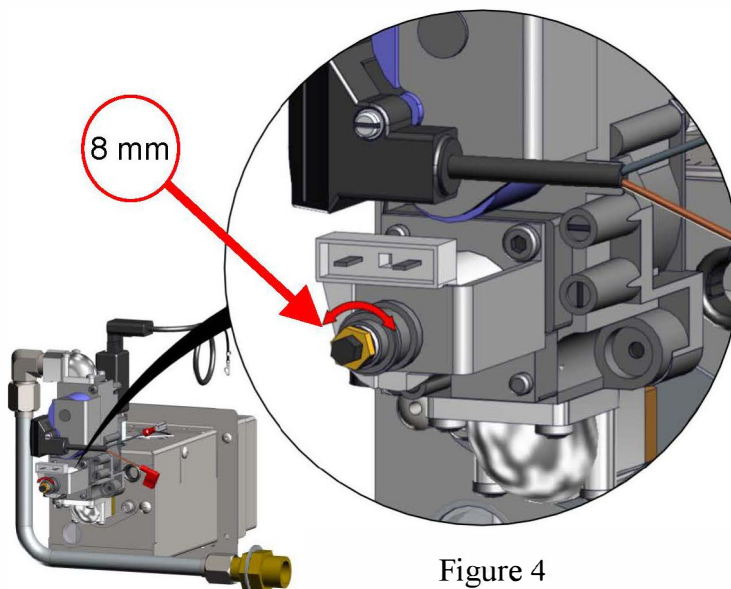

Figure 4

Multi-Valve Adjustment Procedure

Multi-Valve Adjustment Settings						
All Oven Models	Natural Gas			LP Gas		
	W/C	mbar	kPa	W/C	mbar	kPa
High Flame Bias	3.5	8.75	0.875	10	25	2.5
Low Flame Bias	0.1	0.25	0.025	0.5	1.25	0.125

Figure 5

Check Low Bias Pressure:

- Pull one of the two blue wires going into the modulating valve. (This simulates a temperature drop and allows the oven to run at Low Flame Bias)

 If the flame goes out turn the 5mm screw clockwise 1 turn to increase Low Flame Bias

NOTE

- Wait 30 seconds and the oven will re-light.
- Using a 5mm socket turn the Low Flame Bias screw (Figure 6) until desired setting is achieved. Use (Figure 5) for correct valve settings.

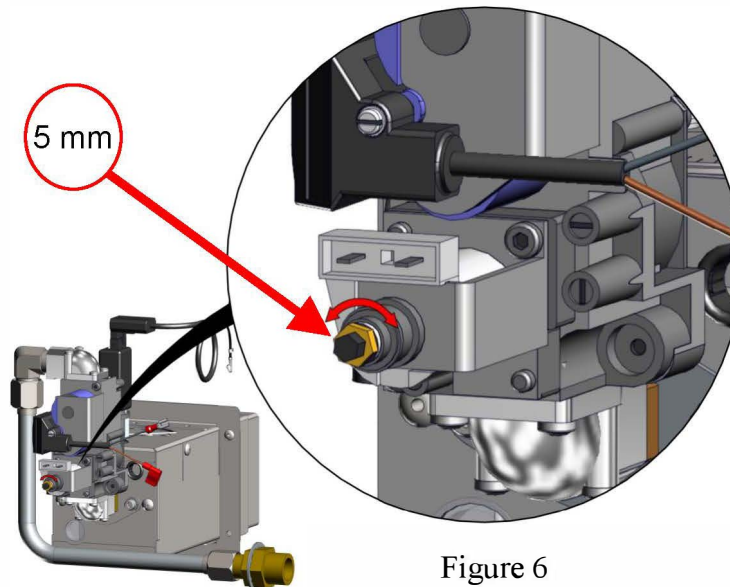

Figure 6

Multi-Valve Adjustment Procedure

Remove the Manometer :

- Turn main switch to the off position
- Remove the manometer and re tighten the screw (Figure 7)
- (Note: Do not over tighten the screw only snug is needed)

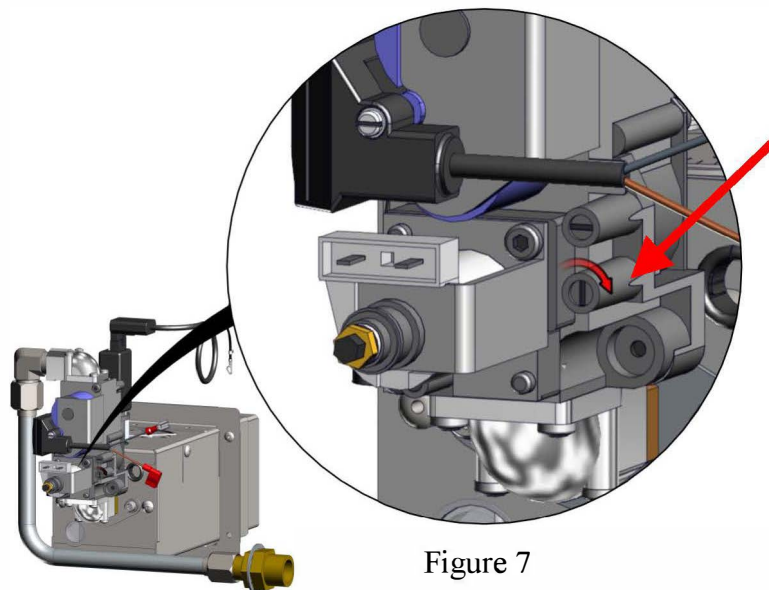
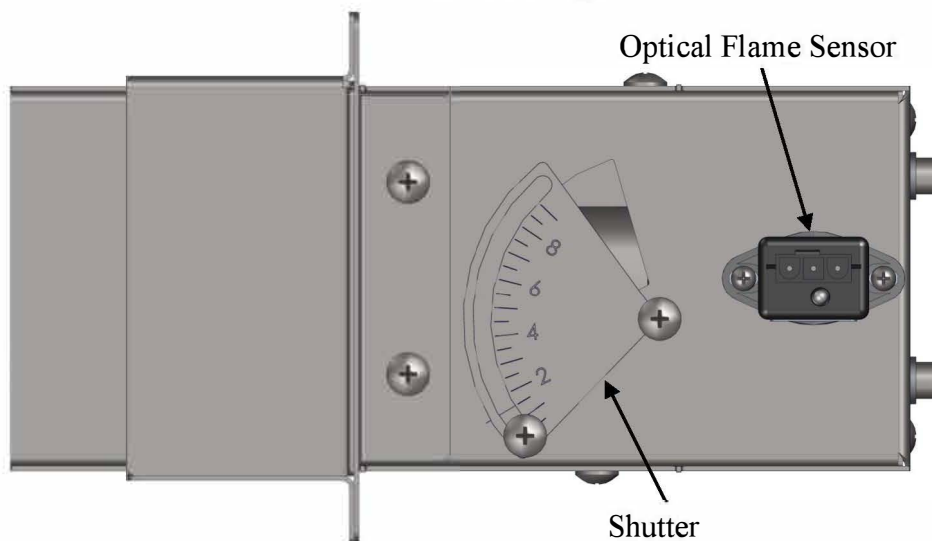

Figure 7

Air Shutter Settings



Burner Shutter Settings		
All Oven Models	Natural Gas	LP Gas
Shutter	1.5	1.5



New Installation– The shutter has been set at the factory. This should not need adjusted. If found loose call technical support for settings.

High Altitude– 6,000 ft and above the shutter may need adjusted. This should only be adjusted to keep flame lit and combustion to a minimum.

Hitachi X200 Restoring AVI Defaults



TIP

Read the entire instruction before programming.

Access program parameters by pressing the <FUNC> button one time and using the up and down arrow buttons to navigate to the appropriate parameter. Press the <FUNC> button again to make adjustments to that parameter by using the up and down arrows. To store the new settings press the <STR> button one time.

B031 = 01

B084 = 01

Press and hold the <FUNC> <Down Arrow> and <Stop/Reset> buttons all at the same time. Release the buttons all at once and the country code should appear in the display (USA). Hitachi's factory settings are now restored.

To install AVI Defaults press <FUNC> button one time and enter following parameters

A001 = 01

A003 – USA = 60 Hz. World = 50 Hz.

A082 = Supply voltage at location 200, 215, or 230 choose appropriate voltage.

A093 = 3000

A094 = 01

A096 = 10

B002 = 25

C001 = 00

C002 = 02

C003 = 03

C004 = 04

C005 = 05

C014 = 00

F001 = See Figure 1

H004 = 4

B031 = 03



Put controller into display mode by pressing the <FUNC> button and holding until d001 appears on the display release and then press the <FUNC> button one time. The display should show 0.0.

Test run the motor by turning on one of the oven/hood switches located on the face of the hood.

Complete VFD manual available at www.xltovens.com.

VFD Controller Settings						
Switches On				1832 & 2440	3240, 3255 & 3270	3855 & 3870
Top	Middle	Bottom				
Single	X			20 Hz	25 Hz	30 Hz
	X			20 Hz	25 Hz	30 Hz
Double			X	35 Hz	40 Hz	45 Hz
	X		X	35 Hz	40 Hz	45 Hz
Triple	X			20 Hz	25 Hz	30 Hz
		X		30 Hz	35 Hz	40 Hz
			X	40 Hz	45 Hz	50 Hz
	X	X		30 Hz	35 Hz	40 Hz
	X		X	40 Hz	45 Hz	50 Hz
		X	X	40 Hz	45 Hz	50 Hz
	X	X	X	45 Hz	50 Hz	55 Hz
Fire Suppression				60 Hz DO NOT CHANGE		

How to order Parts

Have all information ready when calling XLT. Below is a list of information that is required for all orders. At the bottom of the Bill of Materials (BOM) on the following parts overview pages are additional requirements needed depending on your parts order.

Oven/Hood information required:

- Model #
- Serial #
- Manufacture Date
- Phone #
- Contact name
- Bill to
- Ship to
- Credit card information

P.O.R = Price On Request

All prices are subject to change, contact XLT for current prices.

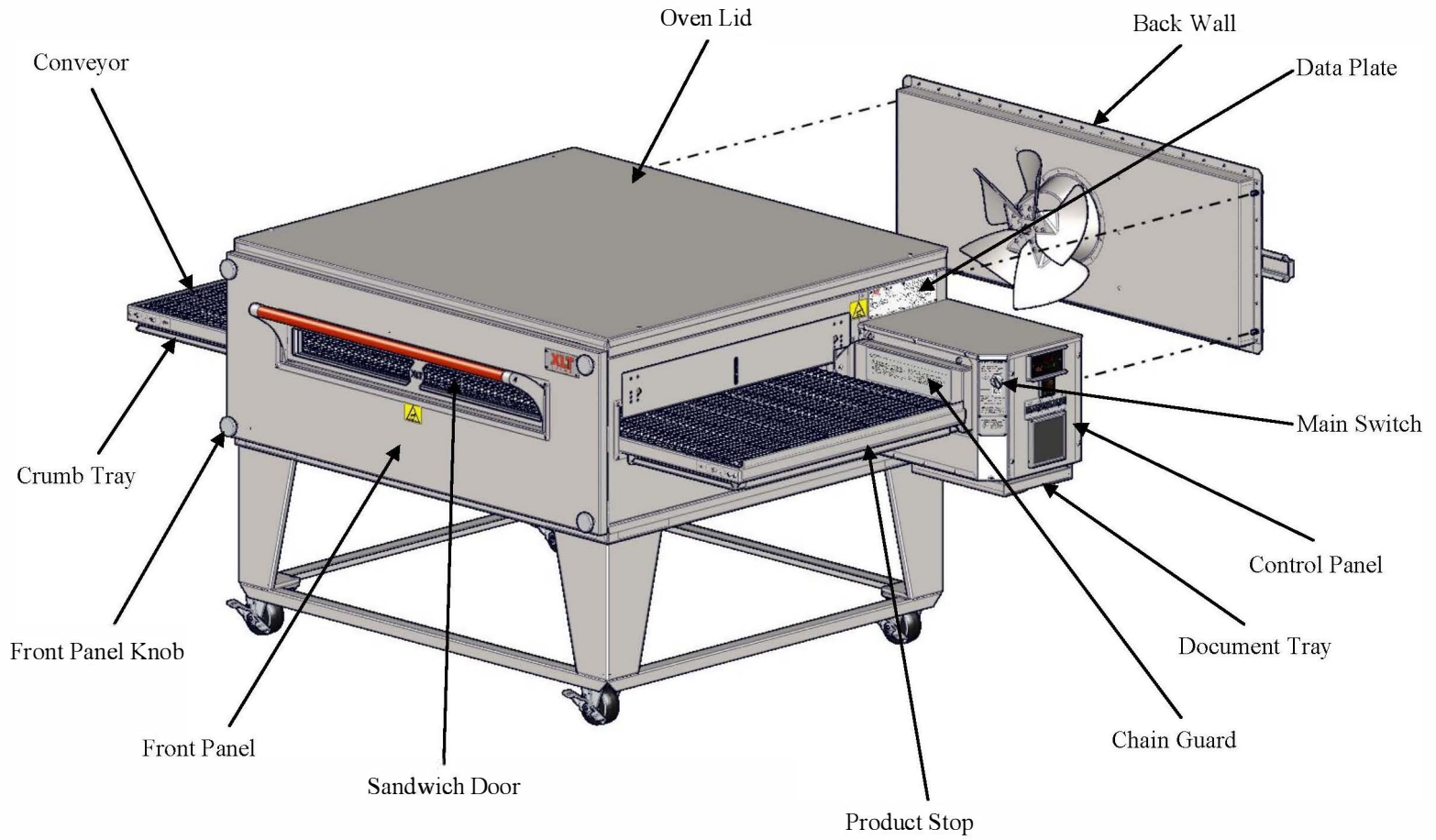

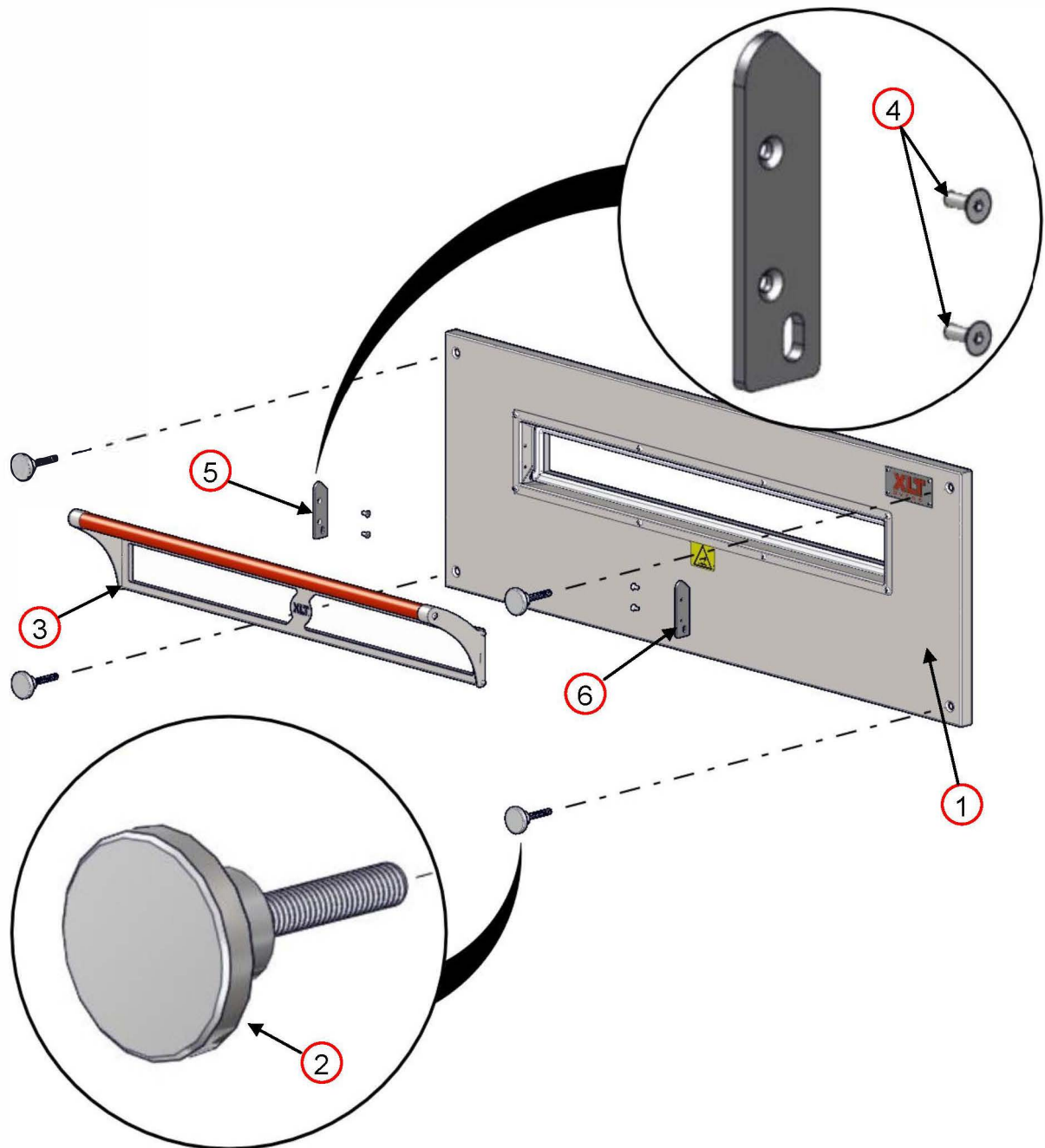

FRONT PANEL			
ITEM	PART NUMBER	DESCRIPTION	YOUR PRICE
1	XA 6500	Front Panel Assembly	P.O.R
2	XA 6505	Front Panel Knob	\$15.90
3	XA 6600	Sandwich Door	P.O.R
4	XF 126-2	Screw 10-24	P.O.R
5	XM 6703	Door Retainer Left	\$13.80
6	XM 6704	Door Retainer Right	\$13.80

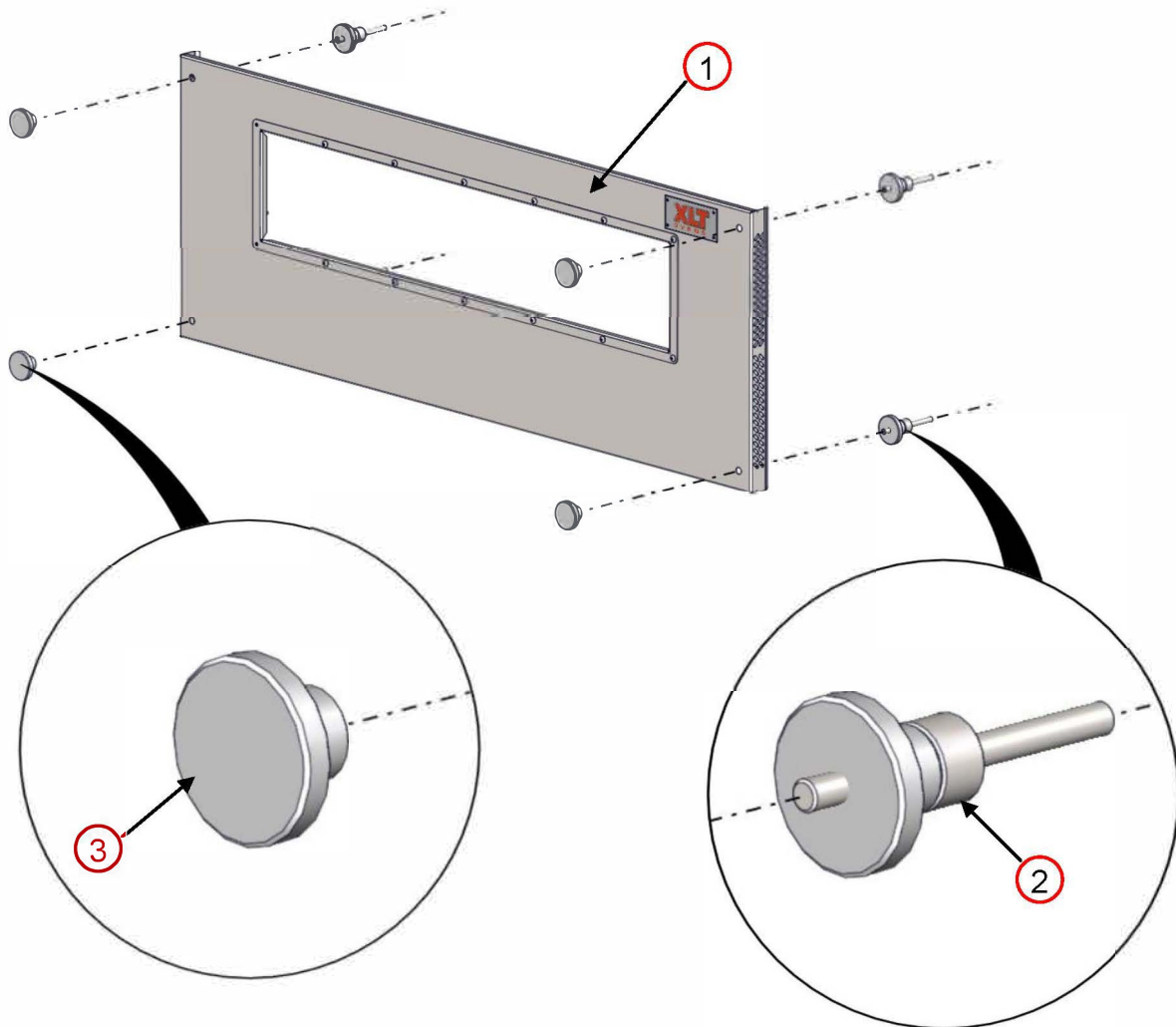

EXTENDED FRONT PANEL			
ITEM	PART NUMBER	DESCRIPTION	YOUR PRICE
1	XA 6700	Extended Front Panel	P.O.R
2	XA 6504	Front Panel Knob Assy Ext Frt	\$33.09
3	XP 6505	Front Panel Knob	\$14.49

Front Panel information required:

- Size of Oven
- Short or Long Window
- Stainless or Wood Handle
- 3” or 5” Window Opening

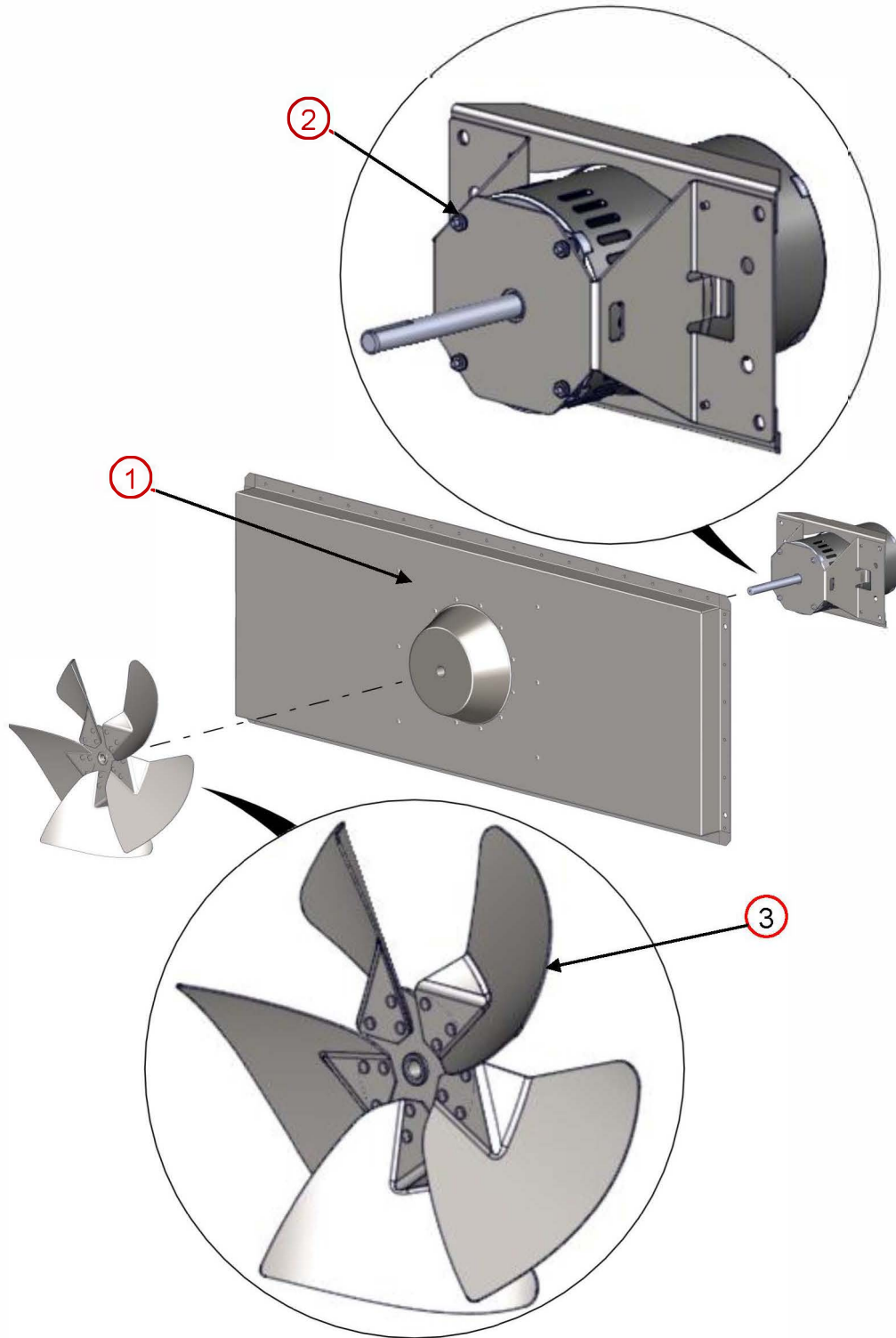

BACK WALL			
ITEM	PART NUMBER	DESCRIPTION	YOUR PRICE
1	XA 50	Back Wall Assembly	P.O.R
2	SP 5009A-75	Fan Motor w/ Mount 3/4 HP	\$283.20
3	XA 5200	Fan Blade	P.O.R

Back Wall information required:

- Size of Oven
- Voltage

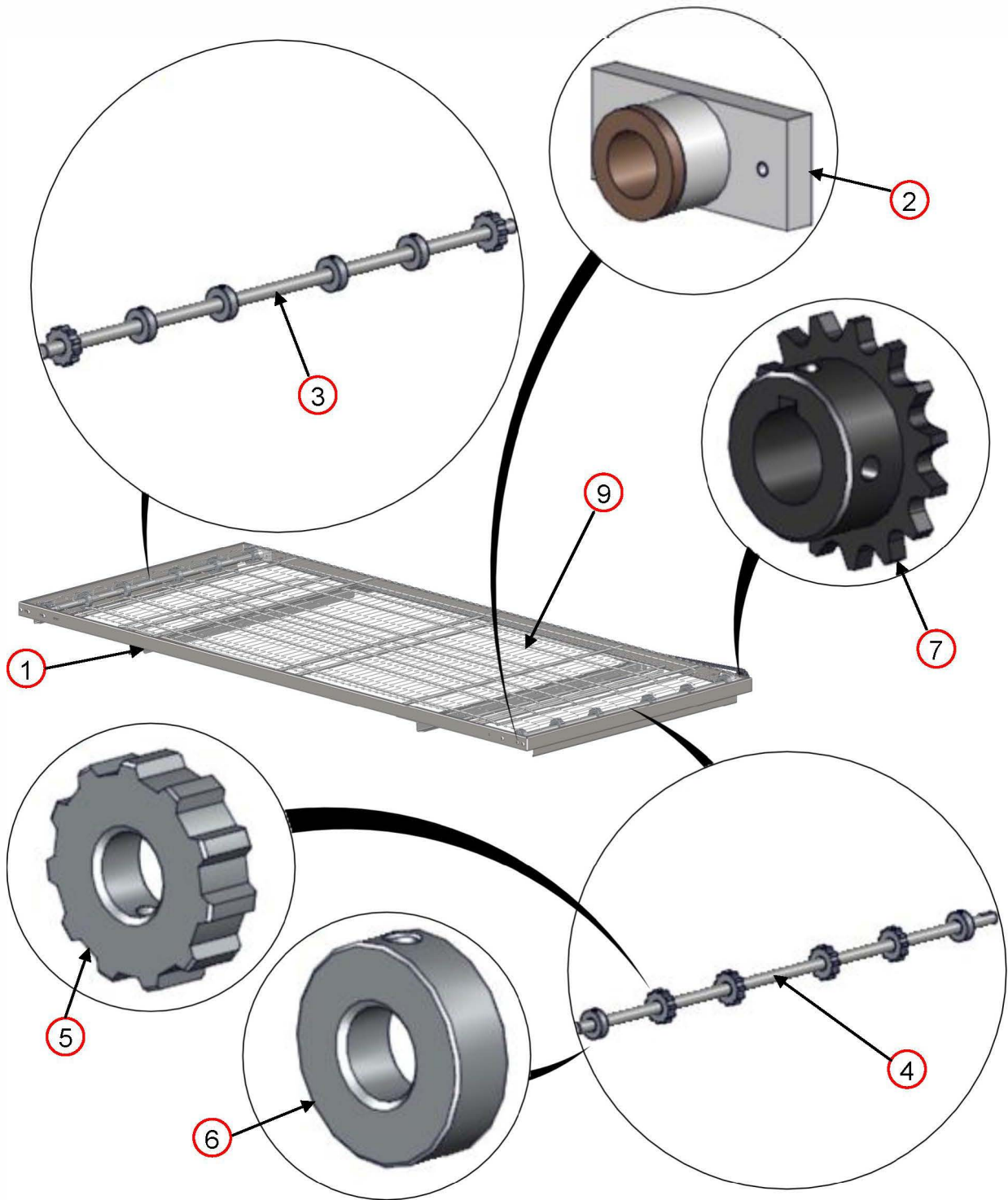

Conveyor Drive Chain not shown

CONVEYOR			
ITEM	PART NUMBER	DESCRIPTION	YOUR PRICE
1	XA 7000	Conveyor Assembly	P.O.R
2	XA 7200	Conveyor Bearing Assembly	\$9.30
3	XM 7301	Conveyor Shaft Idle	P.O.R
4	XM 7302	Conveyor Shaft Drive	P.O.R
5	XP 7403	Conveyor Roll Notched	\$12.20
6	XP 7404	Conveyor Roll Plain	\$11.00
7	XP 9503	Conveyor Sprocket Driven 15	\$15.50
8	XP 9504	Conveyor Drive Chain	\$23.60
9	XP 9506	Conveyor Belt	P.O.R

Conveyor information required:

- Oven Size
- Split Belt or Standard Belt

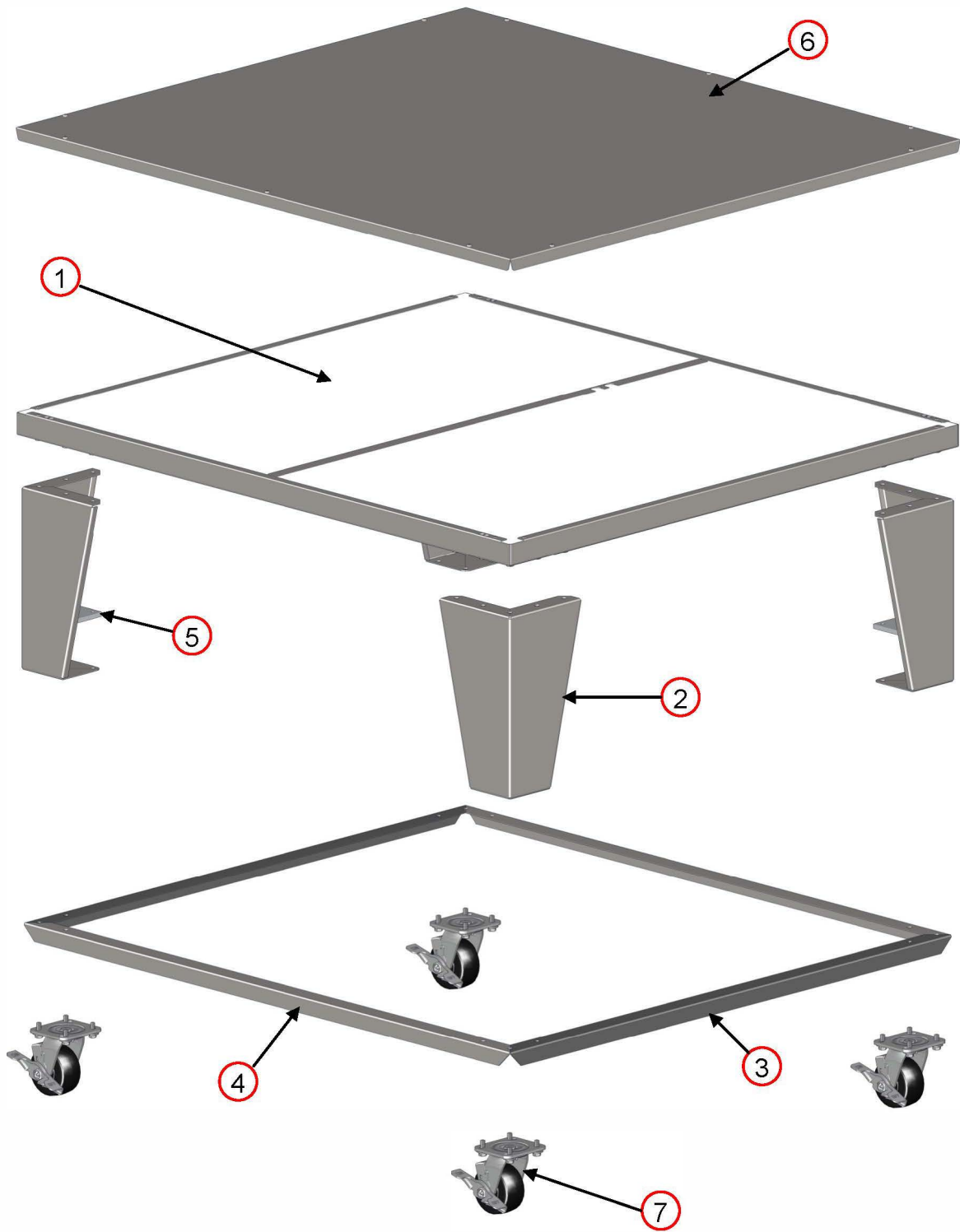

BASE			
ITEM	PART NUMBER	DESCRIPTION	YOUR PRICE
1	XA 1001	Base Assembly	P.O.R
2	XM 1003-15	Base Leg	\$65.40
3	XM 1006	Side Leg Angle	P.O.R
4	XM 1007	Front/Back Leg Angle	P.O.R
5	XM 1008	Bolster Plate	\$11.50
6	XM 1010	Oven Lid	P.O.R
7	XP 1004	Caster	\$21.60

Base information required:

- Size of Oven
- Single, Double, or Triple Stack

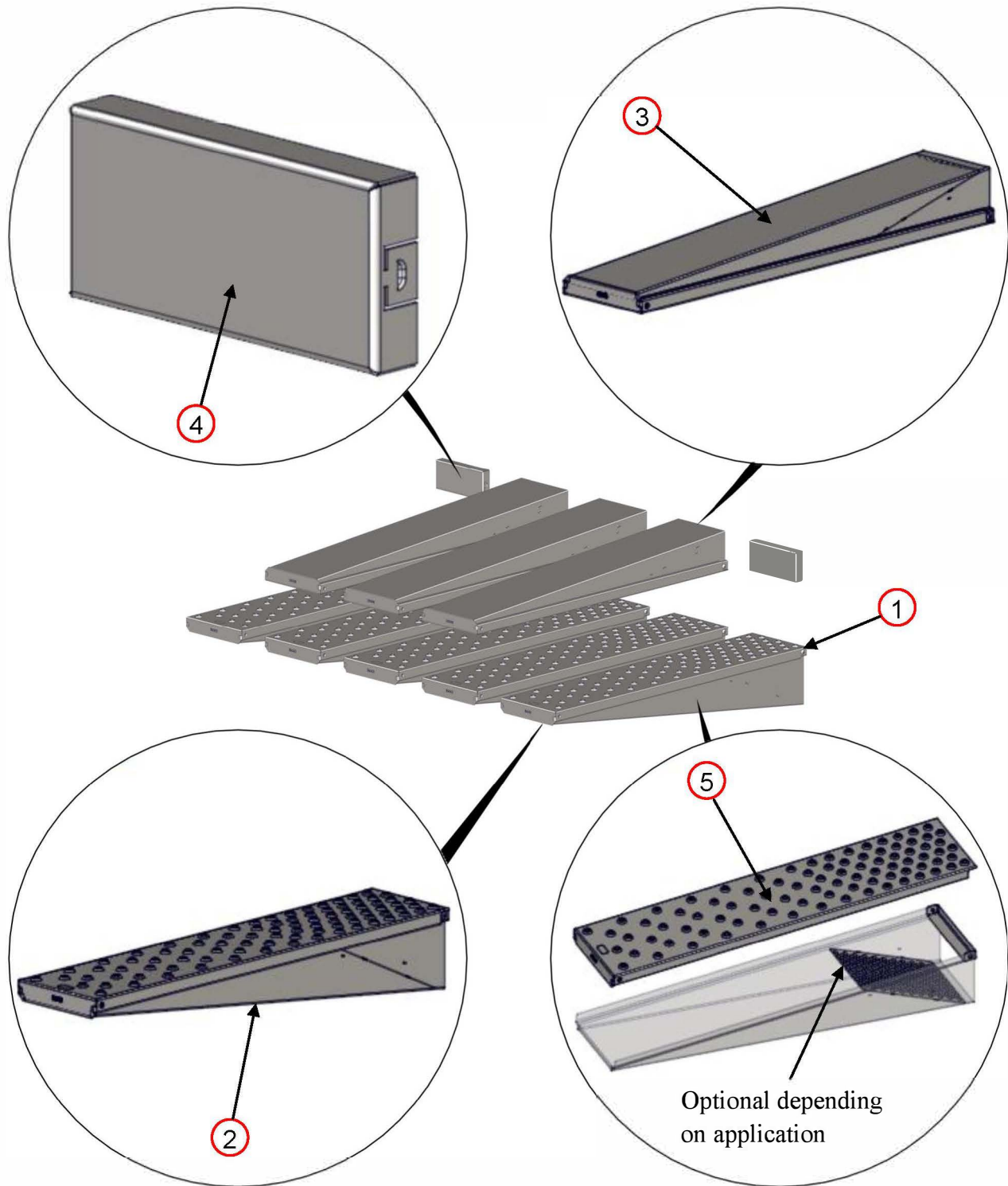

FINGERS			
ITEM	PART NUMBER	DESCRIPTION	YOUR PRICE
1	XA 8Xxxxx	Finger Group Assembly	P.O.R
2	XA 8001-B	Finger Body Bottom	P.O.R
3	XA 8001-T	Finger Body Top	P.O.R
4	XM 8009-S	Finger Block Off Plate	\$12.60
5	XM 8xxx	Finger Outer Plate	P.O.R

Finger information required:

- Size of Oven
- Customer name
- Part number on front of finger outer

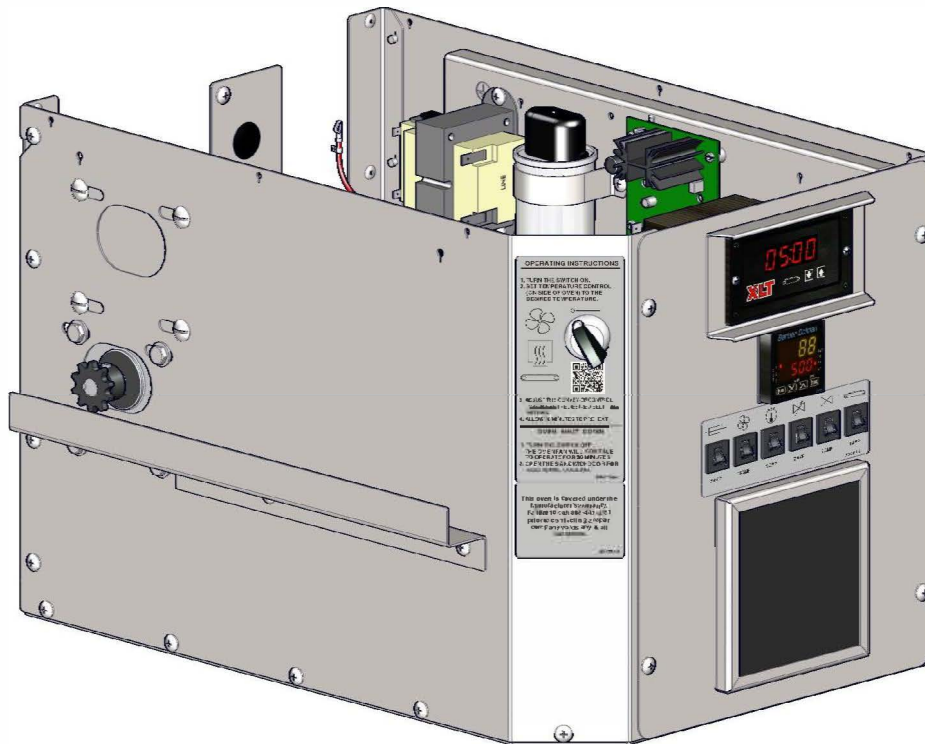

Operating Position (shown with lid removed)

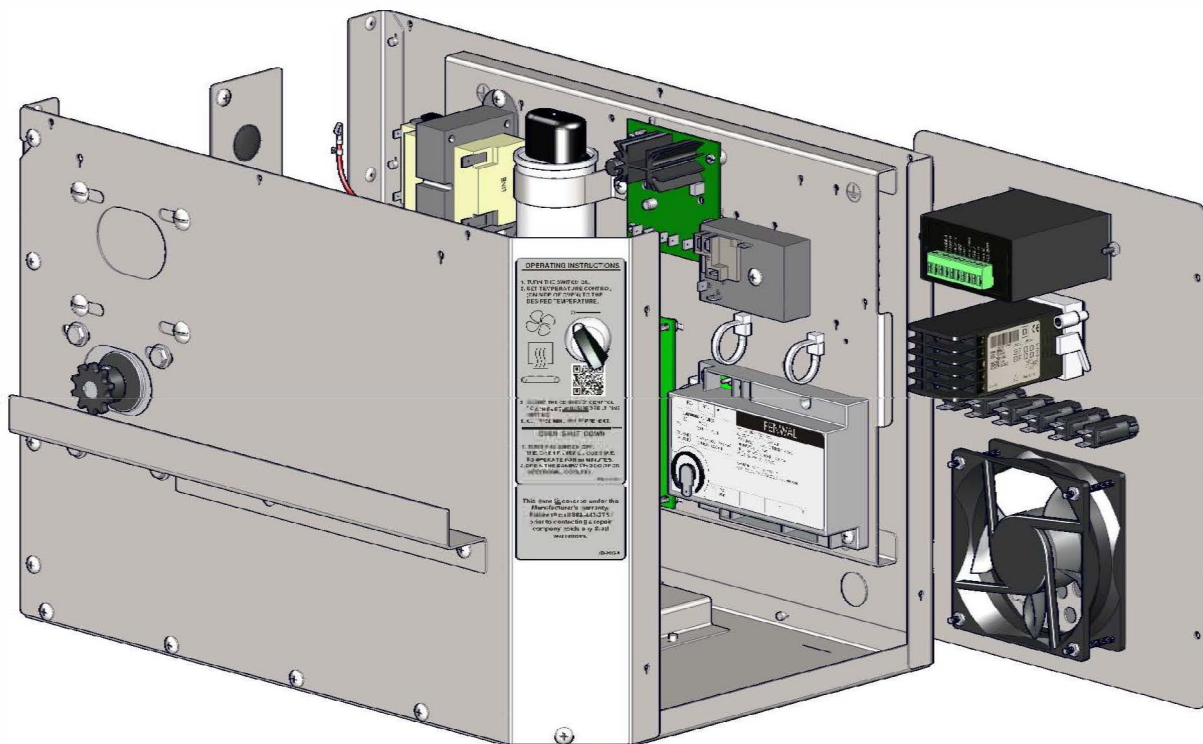

Service Position

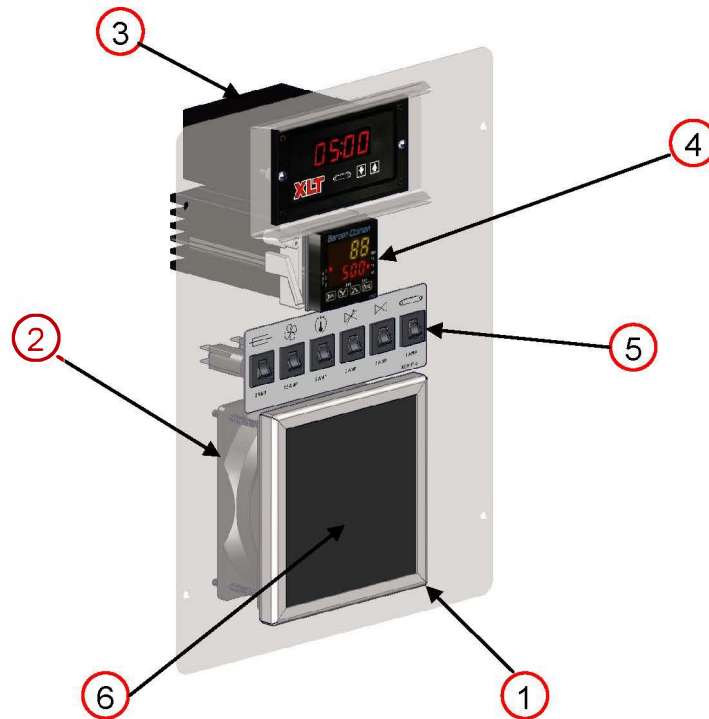

CONTROL PANEL			
ITEM	PART NUMBER	DESCRIPTION	YOUR PRICE
1	SP 4520-GA	Fan Guard / Filter Holder	\$5.60
2	XP 4501-S	FPPG Fan Standard M2	\$36.20
3	XP 4507-24-A	Conveyor Speed Control 24VDC	\$277.10
4	XP 4508	Temperature Control GAS	\$298.30
5	XP 4515-CB	Circuit Breaker	\$6.95
6	XP 4520-GA	Fan Filter	\$1.95

Control Panel information required:

- Size of Oven
- Voltage
- Circuit Breaker amp rating
- Conveyor Belt direction

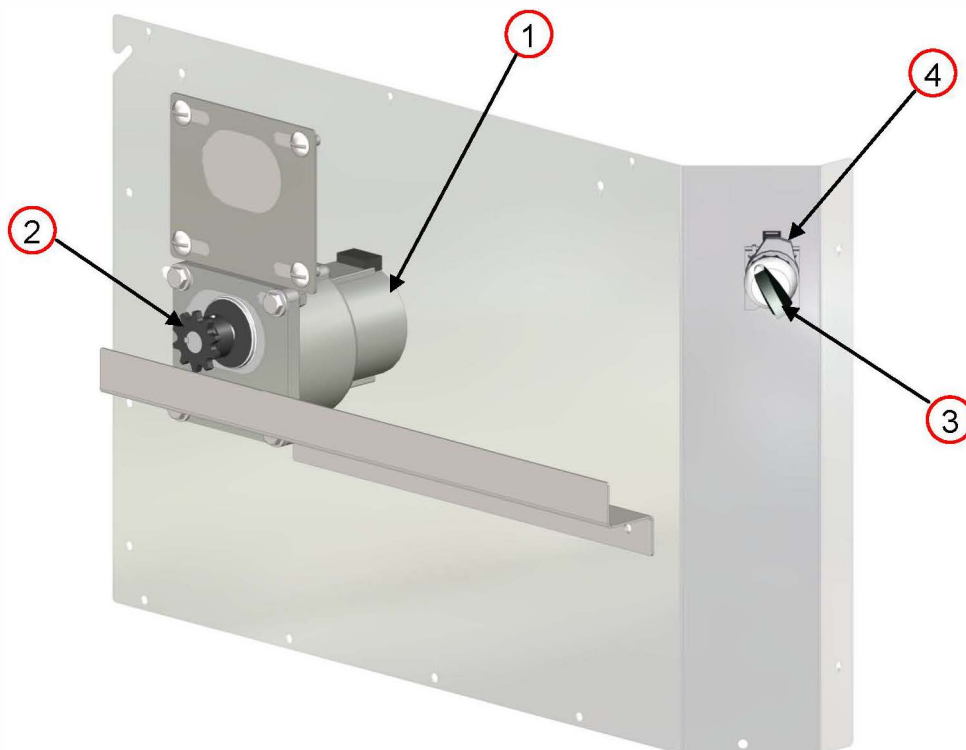

CONTROL BOX FRONT			
ITEM	PART NUMBER	DESCRIPTION	YOUR PRICE
1	XA 4117-12.5 RPM STD	Conv Motor Assy 12.5 RPM STD	\$305.30
2	XP 4155	Sprocket Conveyor Drive 10T	\$15.70
3	XP 4101	Switch Operator	\$21.40
4	XP 4102	Contact Block 1 Pole w/Mount	\$21.40

Control Box Front information required:

- Size of Oven
- Split Belt or Standard Belt

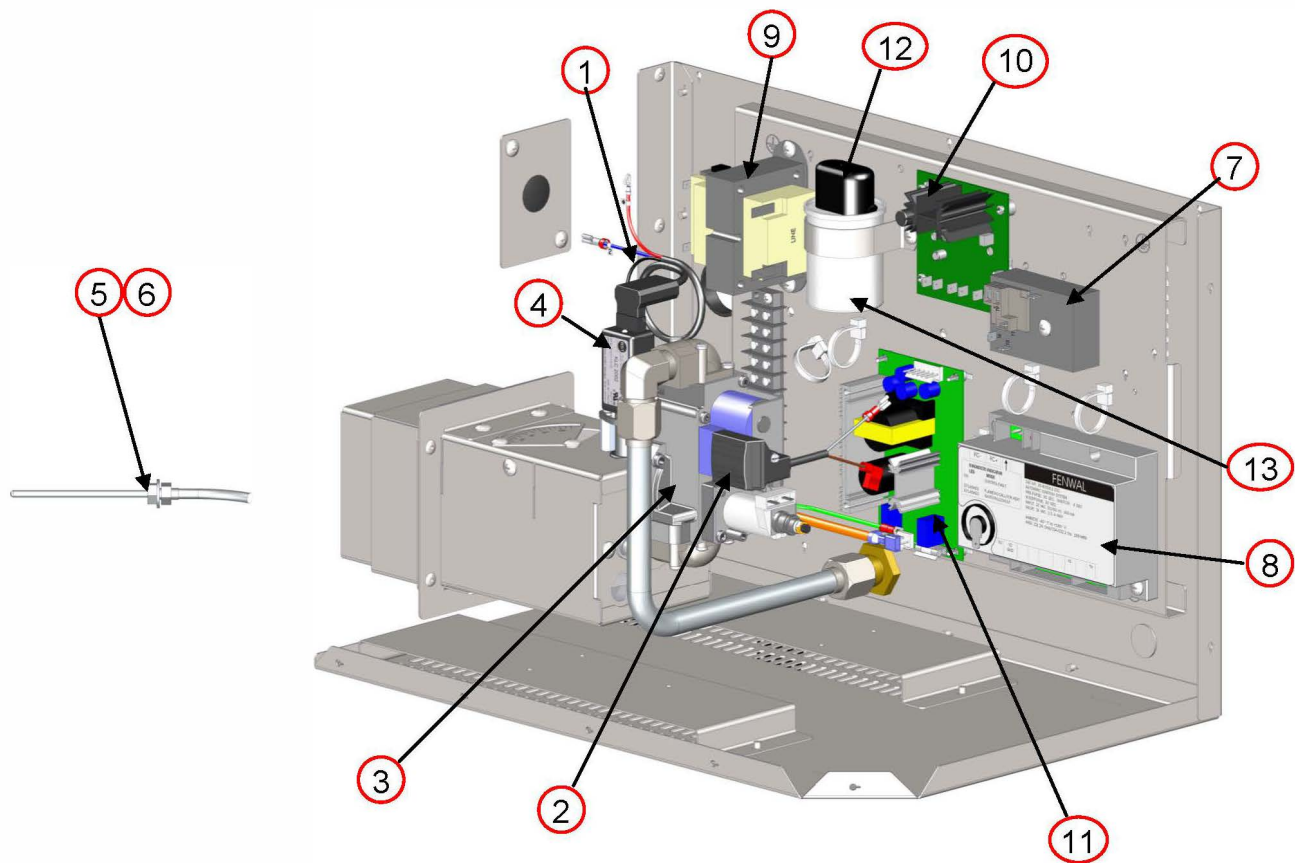

CONTROL BOX BACK			
ITEM	PART NUMBER	DESCRIPTION	YOUR PRICE
1	XA 4211-DC	UV Flame Detector Wire Plug	\$11.46
2	XA 4235	Rectifier Plug Assy	\$15.80
3	XP 4207-DI	Multi- Valve V1 & V2	\$107.30
4	XP 4210-UV-DC	Flame Detector 24VDC	\$109.00
5	XP 4509	Thermocouple Type K 48 (RH)	\$31.80
6	XP 4510	Thermocouple Type K 105 (LH)	\$51.90
7	XP 4704-120 VOLT	Cool Down Timer 120 Volt R1	\$46.70
8	XP 4705-DI	Ignition Control DI RO & SQ	\$77.00
9	XP 4706-S	Transformer 24V 60VA	\$26.30
10	XP 4710-DI	Signal Conditioner Elan	\$60.00
11	XP 4716	Power Supply PS	\$32.40
12	XP 5012	Capacitor Boot	\$2.30
13	XP 5014-30	Capacitor Baldor 3/4 HP 30uF	\$18.60

Control Box Back information required:

- Size of Oven
- Voltage

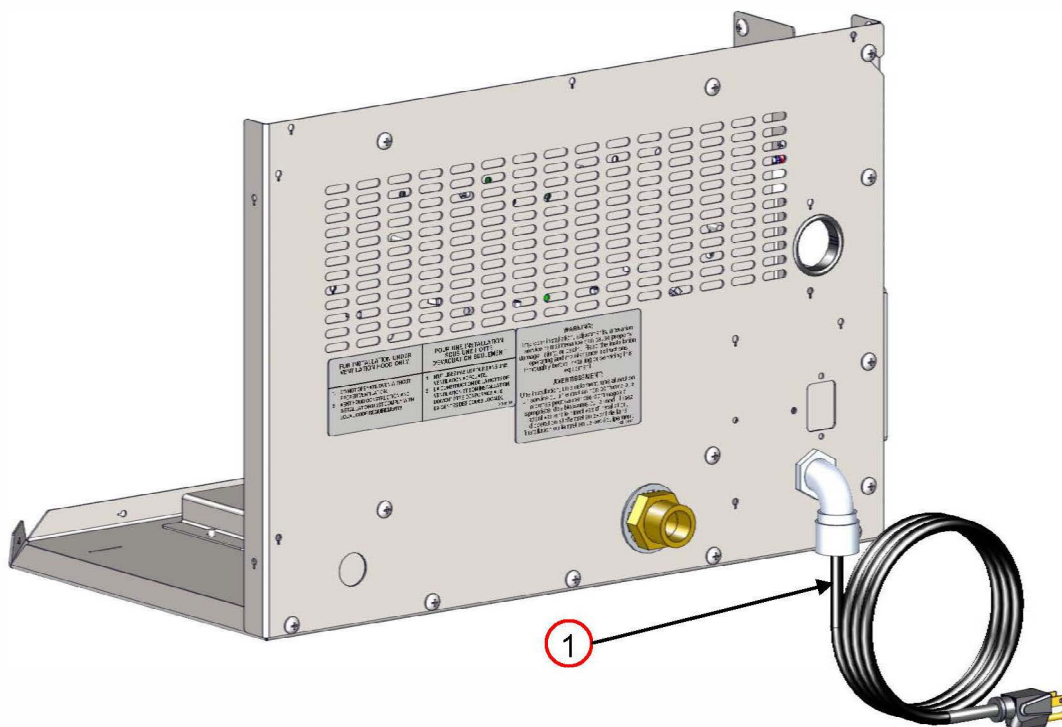

CONTROL BOX REAR			
ITEM	PART NUMBER	DESCRIPTION	YOUR PRICE
1	XA 9301	Power Cord Assembly	\$28.40

Control Box Rear information required:

- Size of Oven
- Voltage

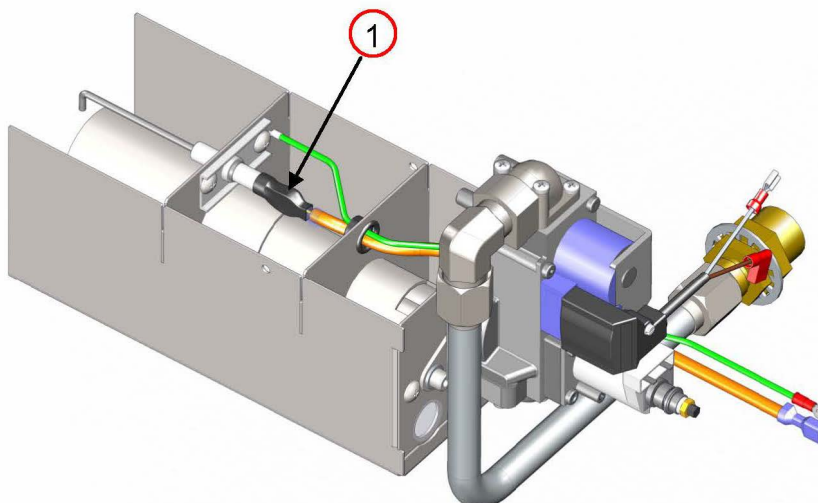

BURNER			
ITEM	PART NUMBER	DESCRIPTION	YOUR PRICE
1	XA 4203-DI-SQ	FS/SI Assembly	\$52.90

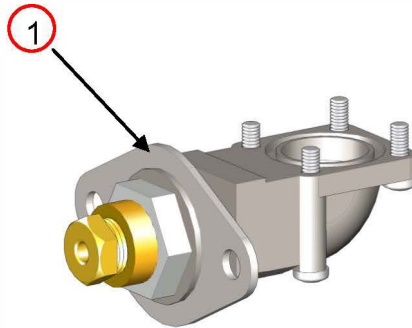

NATURAL GAS VALVE			
ITEM	PART NUMBER	DESCRIPTION	YOUR PRICE
1	SP 9910-QF-Nat	Natural Gas Conversion Kit	\$12.20

Burner information required:

- Size of Oven

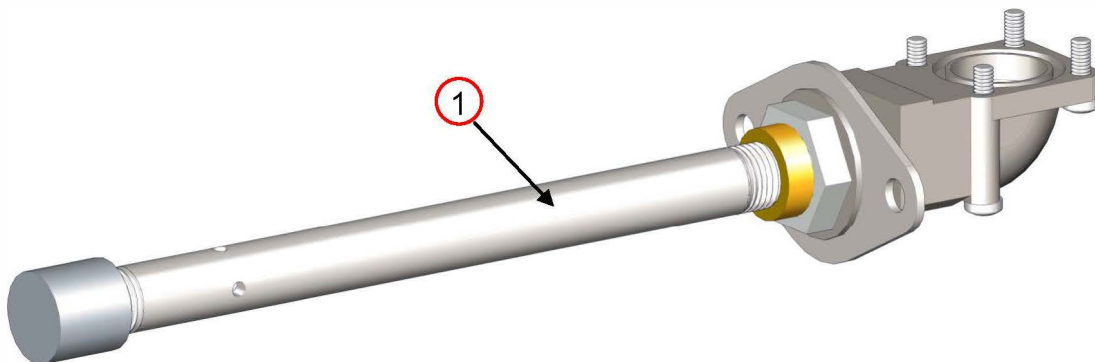

PROPANE VALVE			
ITEM	PART NUMBER	DESCRIPTION	YOUR PRICE
1	SP 9910-QF-Pro	Propane Conversion Kit	\$36.50

Burner information required:

- Size of Oven

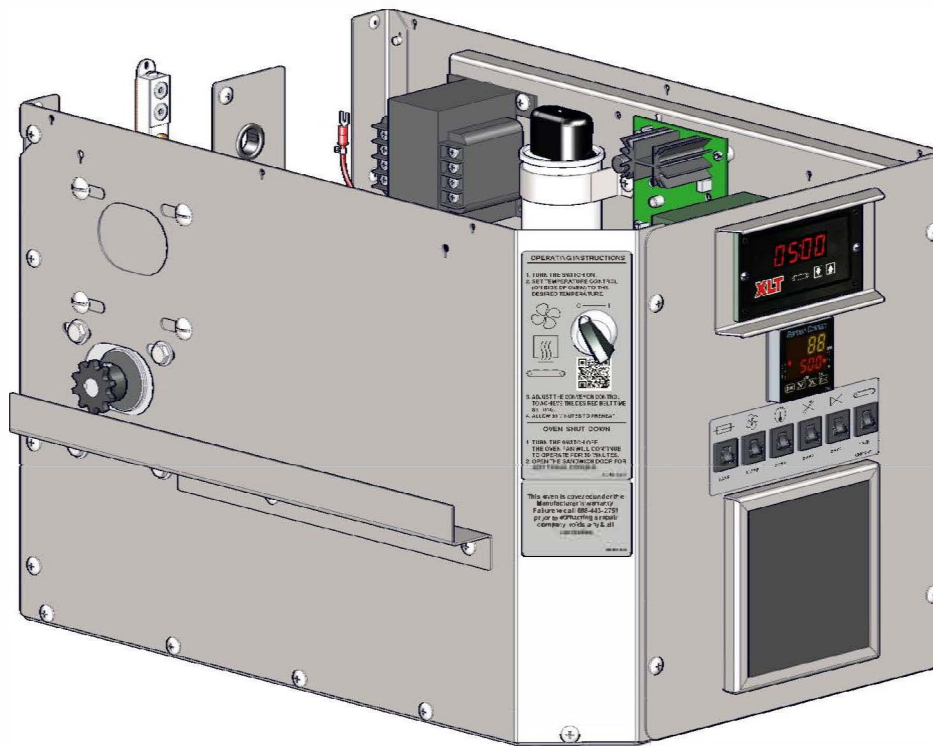

Operating Position (shown with lid removed)

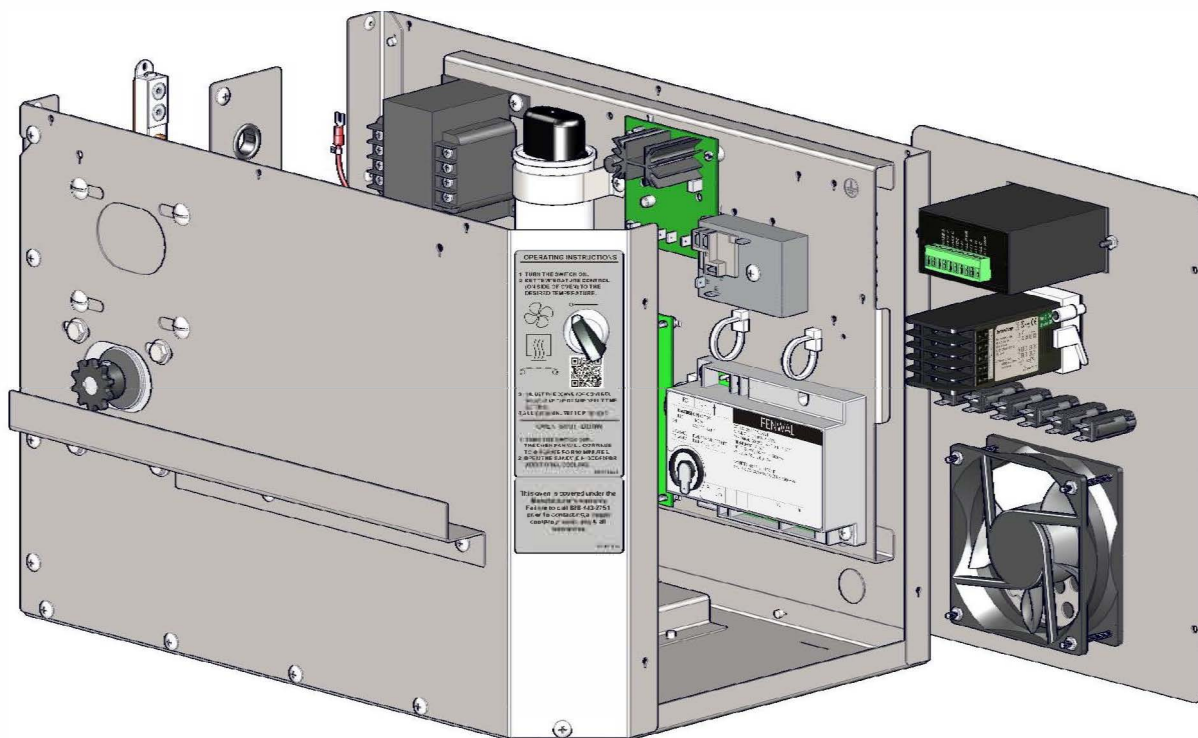

Service Position



CONTROL PANEL			
ITEM	PART NUMBER	DESCRIPTION	YOUR PRICE
1	SP 4520-GA	Fan Guard / Filter Holder	\$5.60
2	XP 4501-W	FPPG Fan Standard M2	\$33.70
3	XP 4507-24-A	Conveyor Speed Control 24VDC	\$277.10
4	XP 4508	Temperature Control GAS	\$298.30
5	XP 4515-CB	Circuit Breaker	\$6.95
6	XP 4520-GA	Fan Filter	\$1.95

Control Panel information required:

- Size of Oven
- Voltage
- Circuit Breaker amp rating
- Conveyor Belt direction

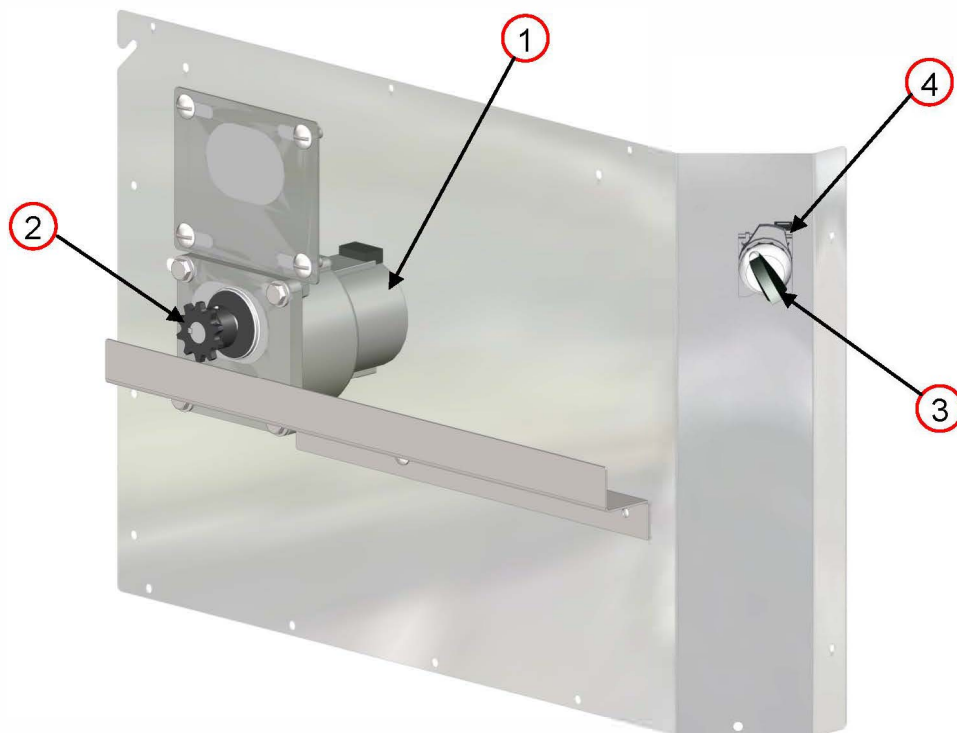

CONTROL BOX FRONT			
ITEM	PART NUMBER	DESCRIPTION	YOUR PRICE
1	XA 4117-12.5 RPM STD	Conv Motor Assy 12.5 RPM STD	\$305.30
2	XP 4155	Sprocket Conveyor Drive 10T	\$15.70
3	XP 4101	Switch Operator	\$21.40
4	XP 4102	Contact Block 1 Pole w/Mount	\$21.40

Control Box Front information required:

- Size of Oven
- Split Belt or Standard Belt

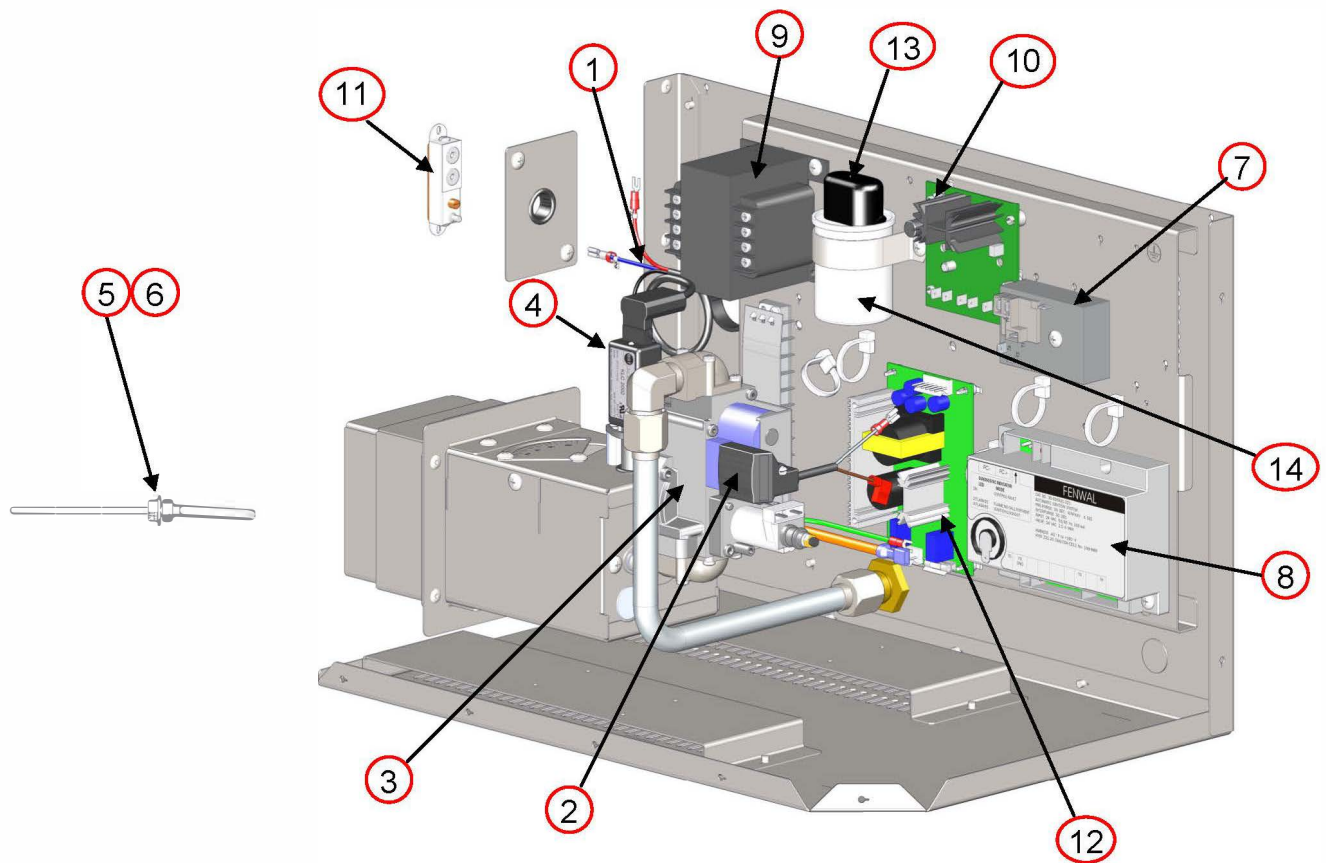

CONTROL BOX BACK			
ITEM	PART NUMBER	DESCRIPTION	YOUR PRICE
1	XA 4211-DC	UV Flame Detector Wire Plug	\$11.46
2	XA 4235	Rectifier Plug Assy	\$15.80
3	XP 4207-DI	Multi-Valve V1 & V2	\$107.30
4	XP 4210-UV-DC	Flame Detector 24 VDC	\$109.00
5	XP 4509	Thermocouple Type K 48 (RH)	\$31.80
6	XP 4510	Thermocouple Type K 105 (LH)	\$51.90
7	XP 4704-230 VOLT	Cool Down Timer 230 Volt R1	\$46.70
8	XP 4705-DI	Ignition Control DI RO & SQ	\$77.00
9	XP 4706-W	Transformer 24V 75VA	\$108.90
10	XP 4710-DI	Signal Conditioner Elan	\$60.00
11	XP 4713	High Temp Limit Switch	\$53.10
12	XP 4716	Power Supply PS	\$32.40
13	XP 5012	Capacitor Boot	\$2.30
14	XP 5014-30	Capacitor Baldor 3/4 HP 30uF	\$18.60

Control Box Back information required:

- Size of Oven
- Voltage

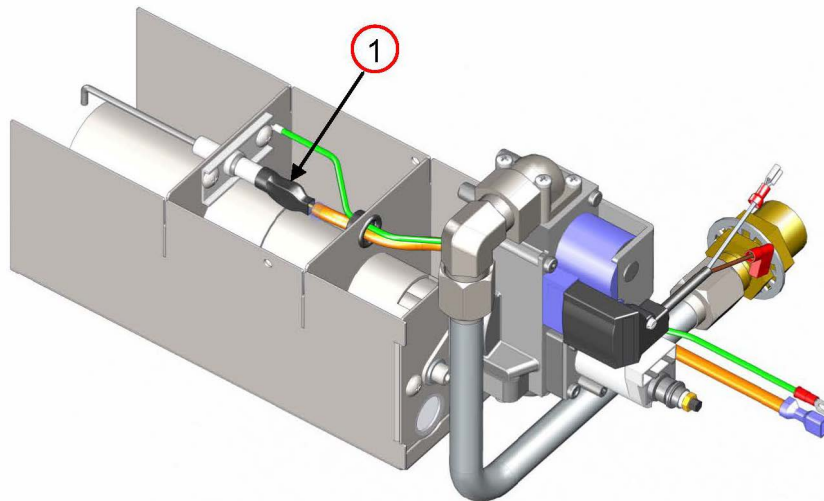
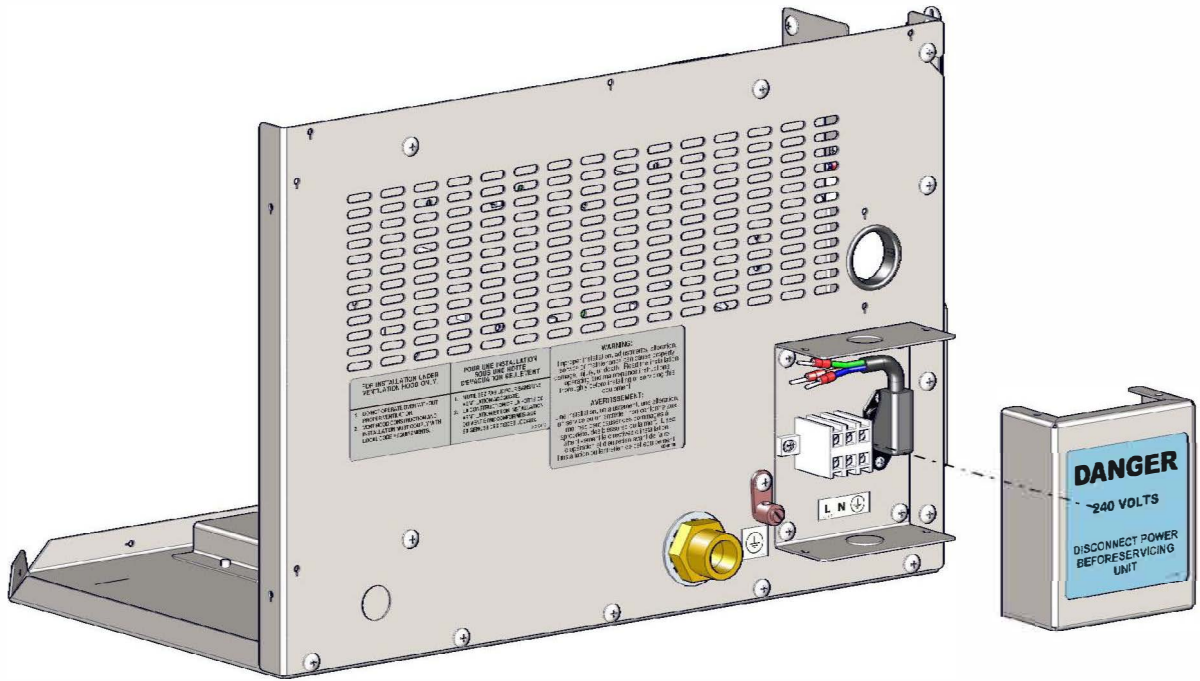

BURNER			
ITEM	PART NUMBER	DESCRIPTION	YOUR PRICE
1	XA 4203-DI-SQ	FS/SI Assembly	\$52.90

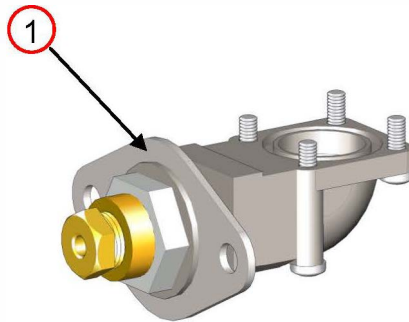

NATURAL GAS VALVE			
ITEM	PART NUMBER	DESCRIPTION	YOUR PRICE
1	SP 9910-QF-Nat	Natural Gas Conversion Kit	\$12.20

Burner information required:

- Size of Oven

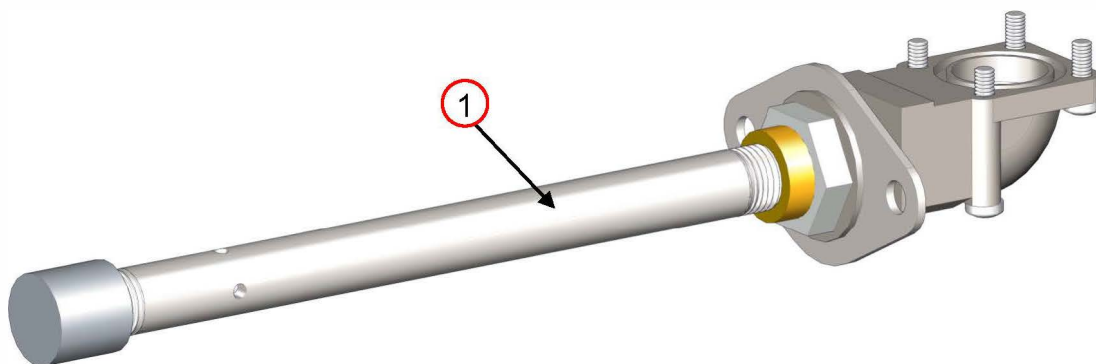

PROPANE VALVE			
ITEM	PART NUMBER	DESCRIPTION	YOUR PRICE
1	SP 9910-QF-Pro	Propane Conversion Kit	\$36.50

Burner information required:

- Size of Oven

This page intentionally left blank.

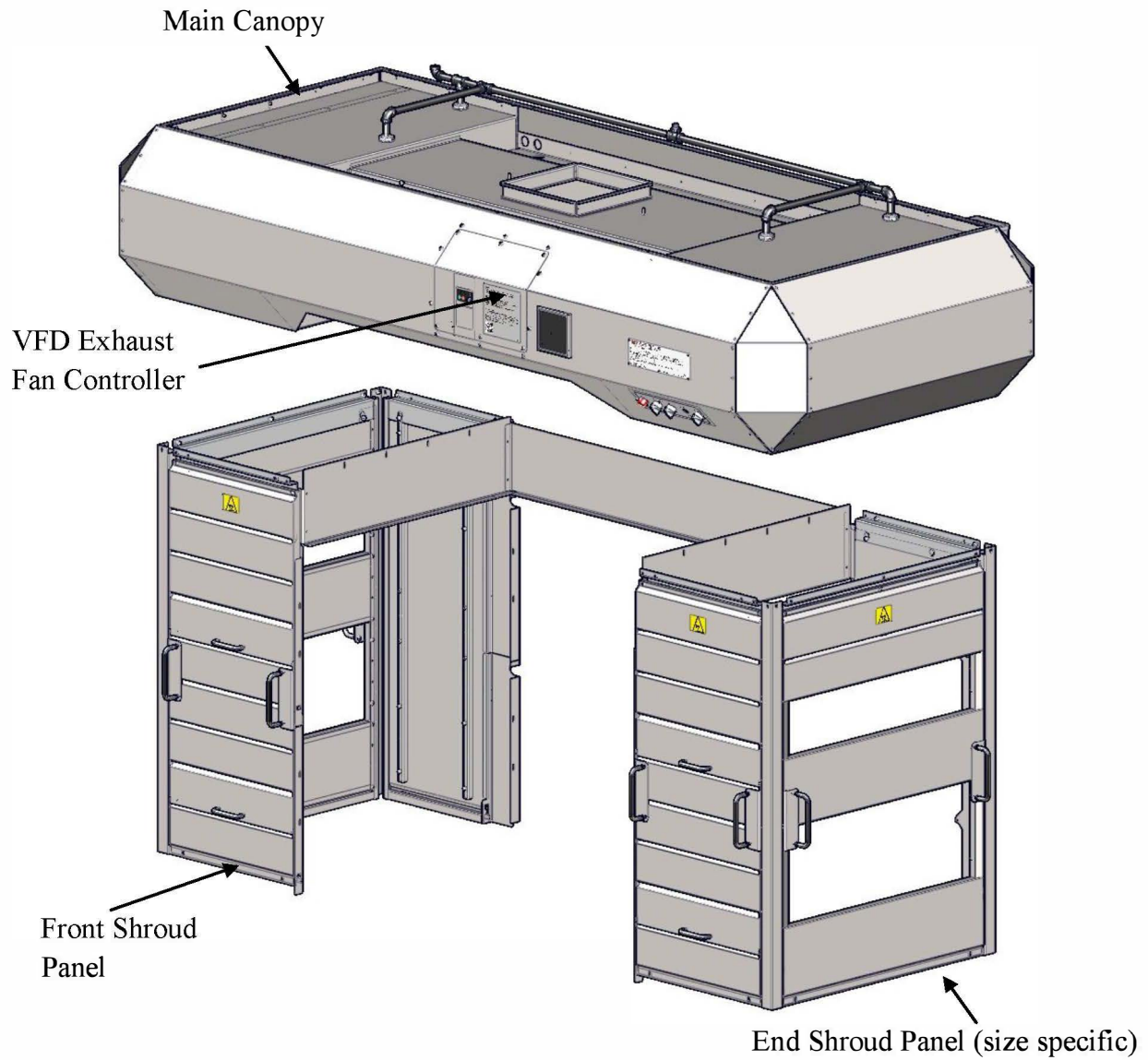

VFD Control Box w/Fire Suppression

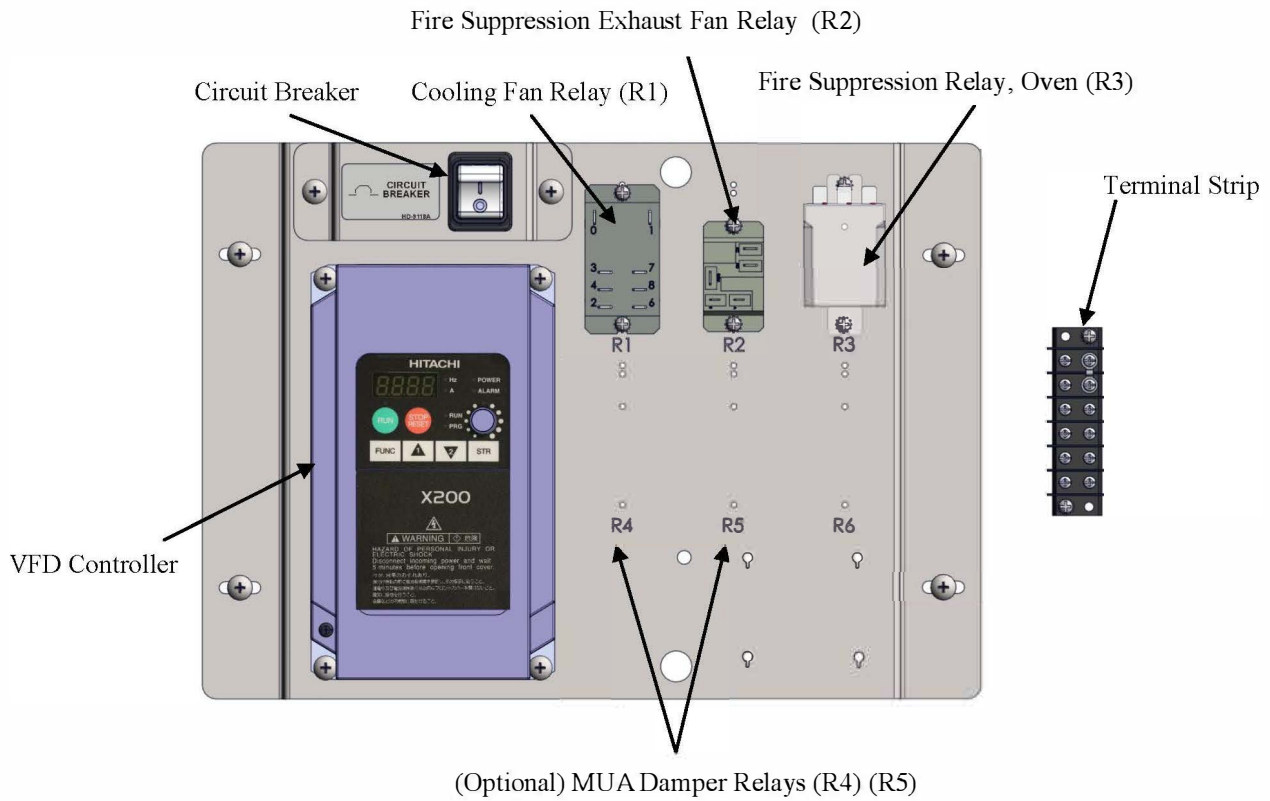

VFD Control Box (Cover removed)

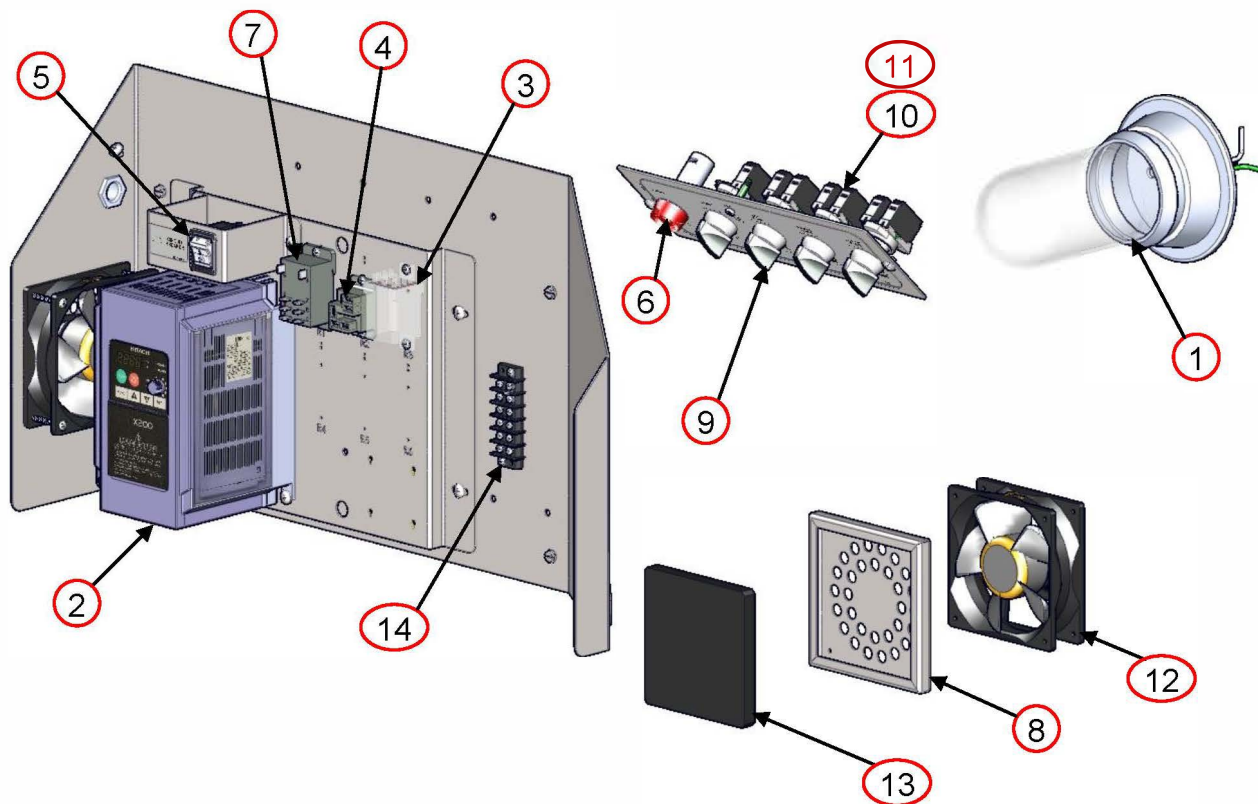

VFD			
ITEM	PART NUMBER	DESCRIPTION	YOUR PRICE
1	HP-1251	Light Assembly	\$57.80
2	HP-2051	VFD Hitachi X200-007NFU	\$198.30
3	HP-2055B	Relay 11 Pin 20A	\$41.30
4	HP-2056B-120VAC	Relay 5 Pin 30A 120VAC	\$31.00
5	HP-2060A	Circuit Breaker Exhaust Fan	\$52.30
6	HP-2063	Alarm and Buzzer	\$25.50
7	HP-2067A-24VDC	Relay 8 Pin 30A 24 VDC	\$23.70
8	SP-4520-GA	Fan Guard / Filter Repl Kit GA	\$5.60
9	XP-4101	Switch Operator	\$21.40
10	XP-4102	Contact Block 1 Pole w/Mount	\$21.40
11	XP-4102-C	Contact Block 1 Pole	\$16.30
12	XP-4501-S	FPPG Fan Standard M2	\$36.20
13	XP-4520-GA	Fan Filter	\$1.95
14	XP-4701-06	Terminal Strip 6 Place	\$5.00

VFD Control Box Back information required:

- Size of Oven
- Voltage

VFD Control Box w/Fire Suppression

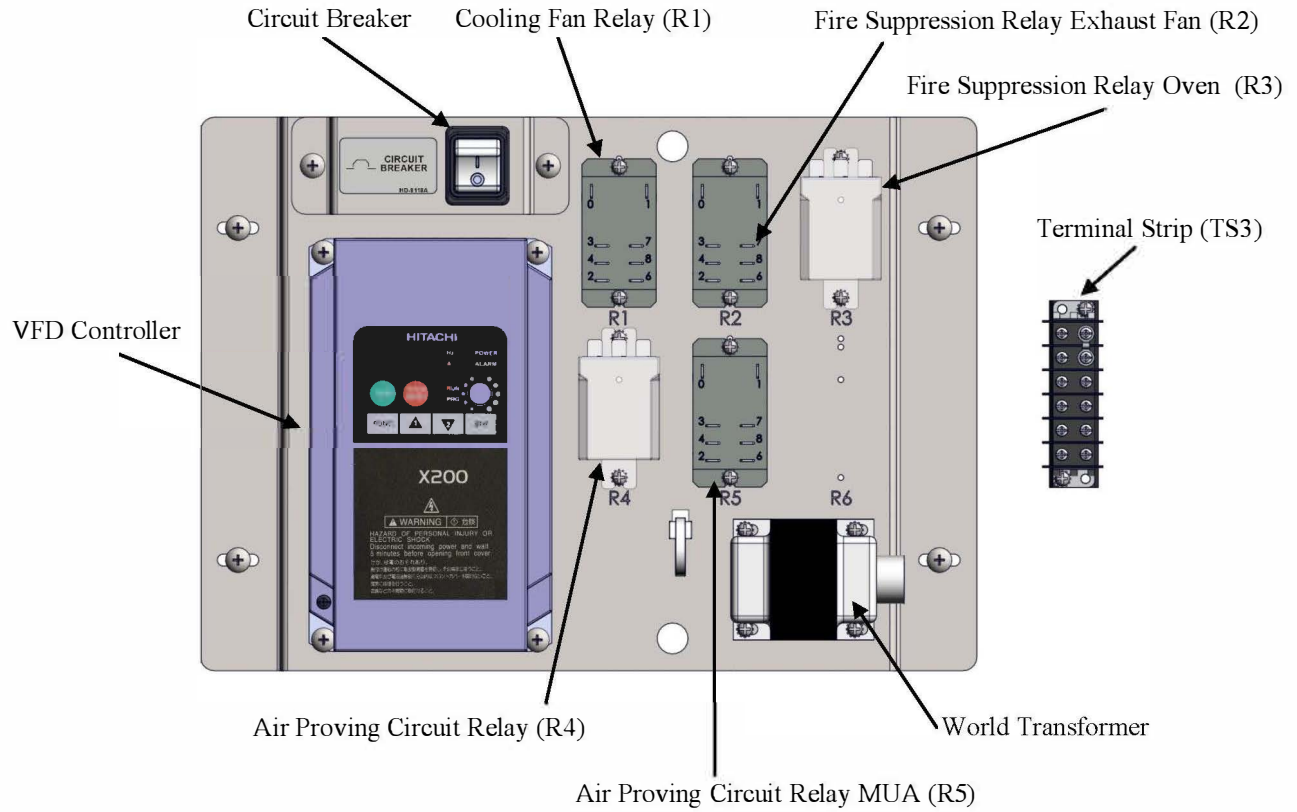

VFD Control Box (Cover removed)

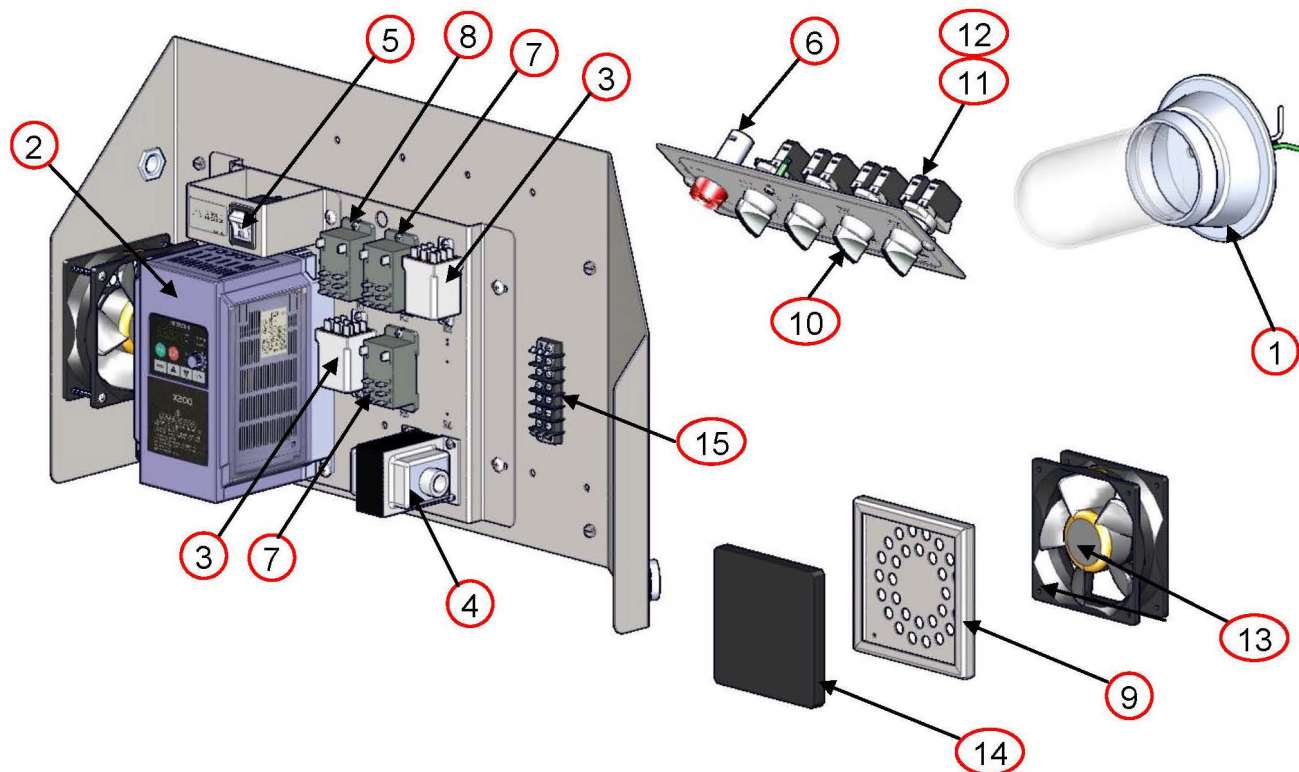

VFD			
ITEM	PART NUMBER	DESCRIPTION	YOUR PRICE
1	HP-1251	Light Assembly	\$57.80
2	HP-2051	VFD Hitachi X200-007NFU	\$198.30
3	HP-2055B	Relay 11 Pin 20A	\$50.50
4	HP-2059	24VAC 40VA World Transformer	\$55.70
5	HP-2060A	Circuit Breaker Exhaust Fan	\$52.30
6	HP-2063	Alarm and Buzzer	\$25.50
7	HP-2067A-24VAC	Relay 8 Pin 30A 24VAC	\$23.70
8	HP-2067A-24VDC	Relay 8 Pin 30A 24VDC	\$19.50
9	SP-4520-GA	Fan Guard / Filter Repl Kit GA	\$5.60
10	XP-4101	Switch Operator	\$21.40
11	XP-4102	Contact Block 1 Pole w/Mount	\$21.40
12	XP-4102-C	Contact Block 1 Pole	\$16.30
13	XP-4501-W	FPPG Fan Standard M2	\$33.70
14	XP-4520-GA	Fan Filter	\$1.95
15	XP-4701-06	Terminal Strip 6 Place	\$5.00

VFD Control Box Back information required:

- Size of Oven
- Voltage

This page intentionally left blank.

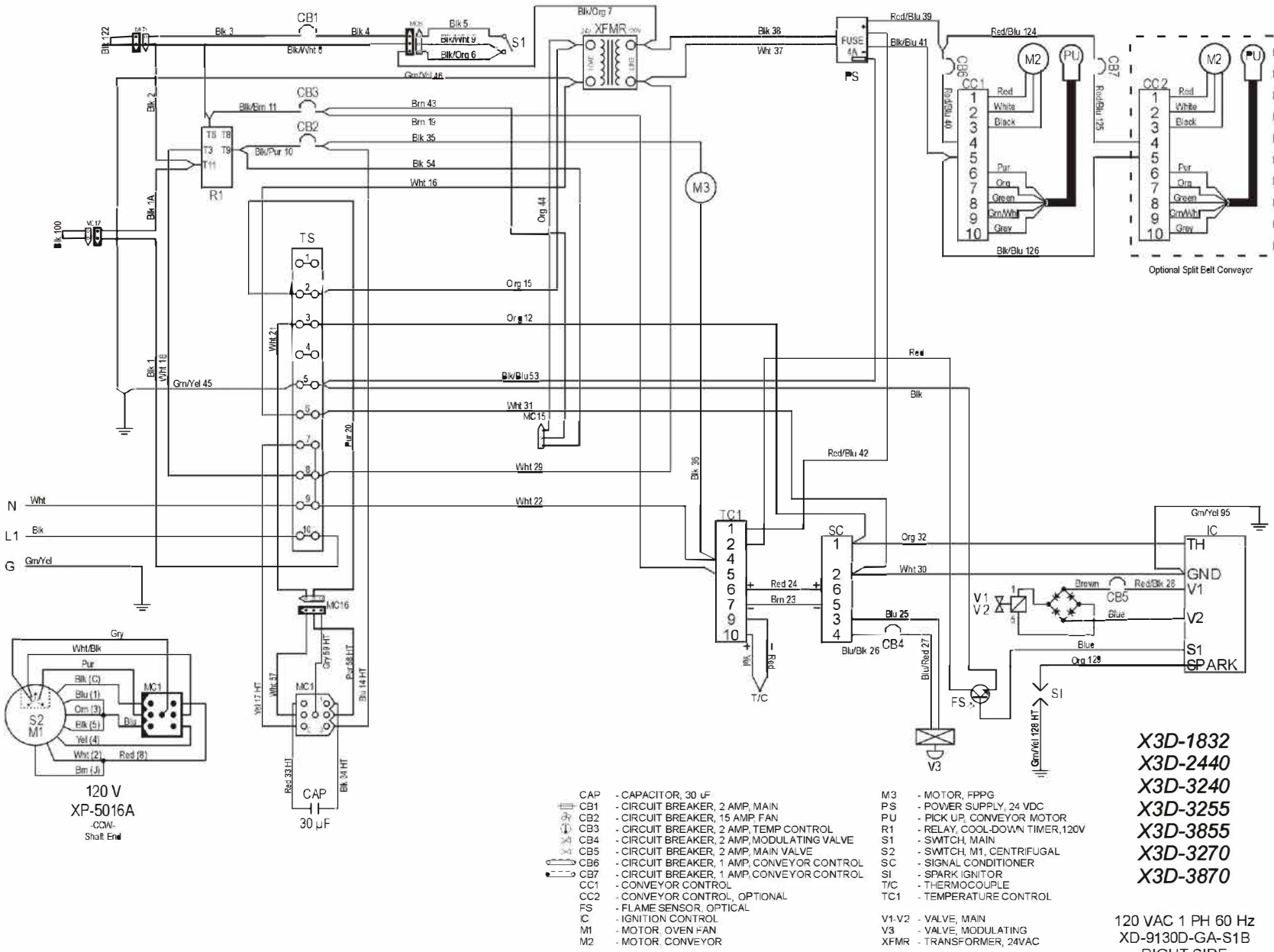

- X3D-1832
- X3D-2440
- X3D-3240
- X3D-3255
- X3D-3855
- X3D-3270
- X3D-3870

120 VAC 1 PH 60 Hz
XD-9130D-GA-S1B
RIGHT SIDE
02/01/2013

60 OVEN SCHEMATIC - WORLD & KOREA 1 BOX 230 VAC

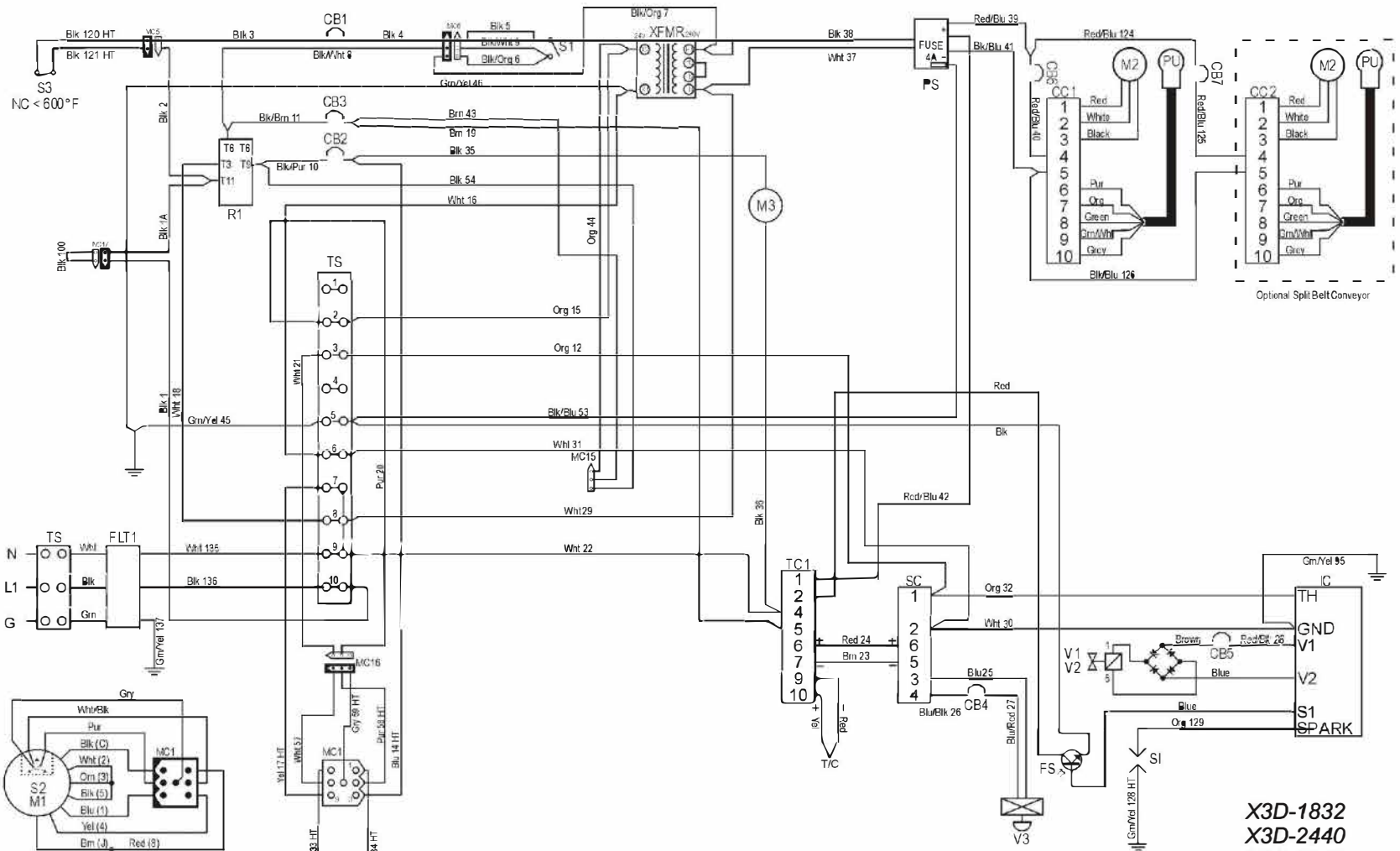

208/240 V
XP-5016A
-COW
Shaft End

- | | | | |
|------|--|-------|--------------------------------|
| CAP | - CAPACITOR, 30 uF | PS | - POWER SUPPLY 24 VDC |
| CB1 | - CIRCUIT BREAKER, 2 AMP, MAIN | PU | - PICK UP, CONVEYOR MOTOR |
| CB2 | - CIRCUIT BREAKER, 10 AMP, FAN | R1 | - RELAY, COOL-DOWN TIMER, 230V |
| CB3 | - CIRCUIT BREAKER, 2 AMP, TEMP CONTROL | S1 | - SWITCH, MAIN |
| CB4 | - CIRCUIT BREAKER, 2 AMP, MODULATING VALVE | S2 | - SWITCH, M1, CENTRIFUGAL |
| CB5 | - CIRCUIT BREAKER, 2 AMP, MAIN VALVE | S3 | - SWITCH, HIGH LIMIT |
| CB6 | - CIRCUIT BREAKER, 1 AMP, CONVEYOR CONTROL | SC | - SIGNAL CONDITIONER |
| CB7 | - CIRCUIT BREAKER, 1 AMP, CONVEYOR CONTROL | S1 | - SPARK IGNITOR |
| CC1 | - CONVEYOR CONTROL | T/C | - THERMOCOUPLE |
| CC2 | - CONVEYOR CONTROL, OPTIONAL | TC1 | - TEMPERATURE CONTROL |
| FLT1 | - FILTER, POWER INLET | V1-V2 | - VALVE, MAIN |
| FS | - FLAME SENSOR, OPTICAL | V3 | - VALVE, MODULATING |
| IC | - IGNITION CONTROL | XFMR | - TRANSFORMER, 24 VAC |
| M1 | - MOTOR, OVEN FAN | | |
| M2 | - MOTOR, CONVEYOR | | |
| M3 | - MOTOR, FPPG | | |

- X3D-1832**
X3D-2440
X3D-3240
X3D-3255
X3D-3855
X3D-3270
X3D-3870

230 VAC 1 PH 50/60 Hz
XD-9130D-GA-W1B
RIGHT SIDE
02/01/2013

Technical Support US: 888-443-2751



Technical Support INTL: 316-943-2751

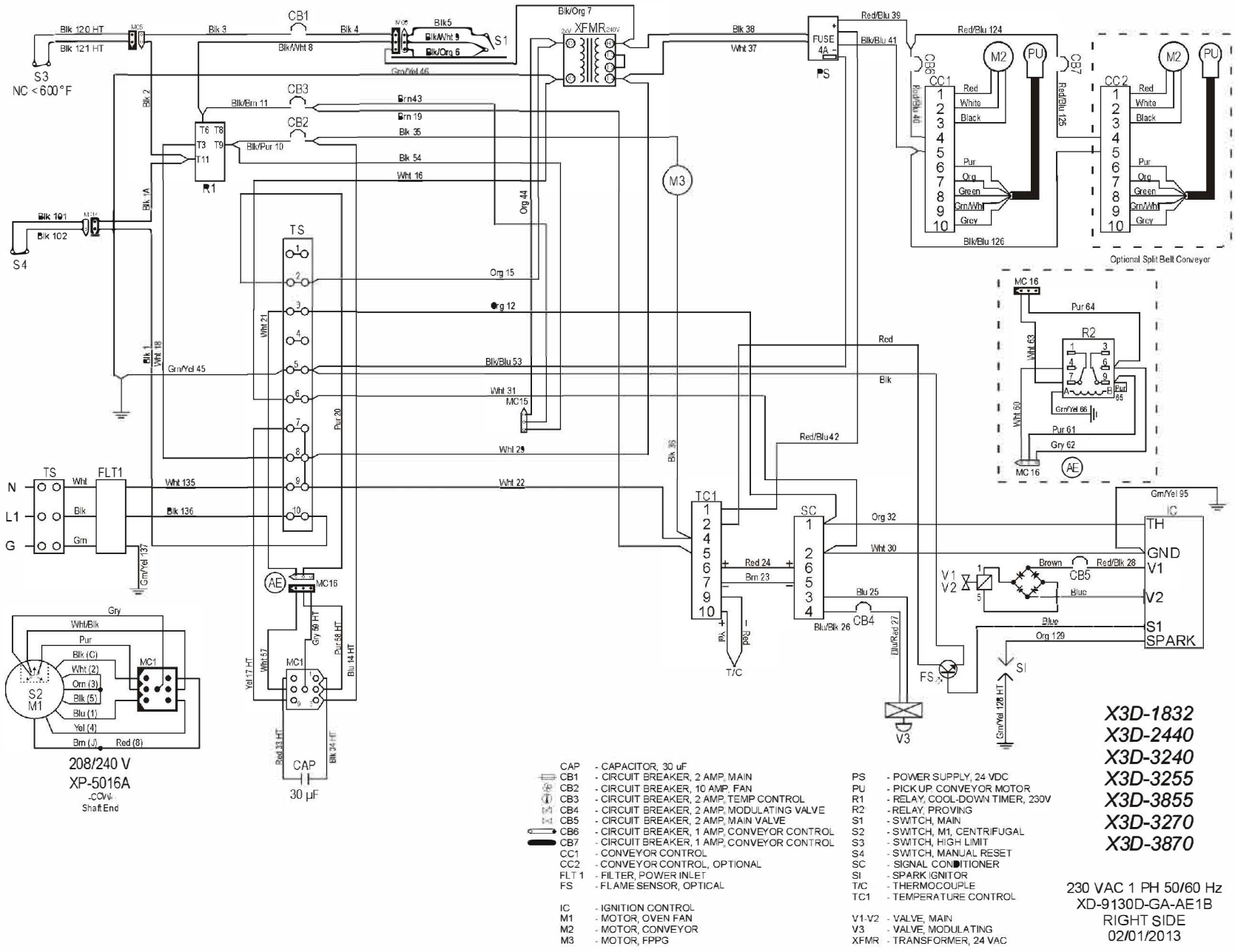

208/240 V
XP-5016A
-C.O.V.
Shaft End

- CAP - CAPACITOR, 30 uF
- CB1 - CIRCUIT BREAKER, 2 AMP, MAIN
- CB2 - CIRCUIT BREAKER, 10 AMP, FAN
- CB3 - CIRCUIT BREAKER, 2 AMP, TEMP CONTROL
- CB4 - CIRCUIT BREAKER, 2 AMP, MODULATING VALVE
- CB5 - CIRCUIT BREAKER, 2 AMP, MAIN VALVE
- CB6 - CIRCUIT BREAKER, 1 AMP, CONVEYOR CONTROL
- CB7 - CIRCUIT BREAKER, 1 AMP, CONVEYOR CONTROL
- CC1 - CONVEYOR CONTROL, OPTIONAL
- CC2 - CONVEYOR CONTROL, OPTIONAL
- FLT 1 - FILTER, POWER INLET
- FS - FLAME SENSOR, OPTICAL
- IC - IGNITION CONTROL
- M1 - MOTOR, OVEN FAN
- M2 - MOTOR, CONVEYOR
- M3 - MOTOR, FPPG
- PS - POWER SUPPLY, 24 VDC
- PU - PICKUP CONVEYOR MOTOR
- R1 - RELAY, COOL-DOWN TIMER, 230V
- R2 - RELAY, PROVING
- S1 - SWITCH, MAIN
- S2 - SWITCH, M1, CENTRIFUGAL
- S3 - SWITCH, HIGH LIMIT
- S4 - SWITCH, MANUAL RESET
- SC - SIGNAL CONDITIONER
- S1 - SPARK IGNITOR
- T/C - THERMOCOUPLE
- TC1 - TEMPERATURE CONTROL
- V1-V2 - VALVE, MAIN
- V3 - VALVE, MODULATING
- XFMR - TRANSFORMER, 24 VAC

- X3D-1832
- X3D-2440
- X3D-3240
- X3D-3255
- X3D-3855
- X3D-3270
- X3D-3870

230 VAC 1 PH 50/60 Hz
XD-9130D-GA-AE1B
RIGHT SIDE
02/01/2013

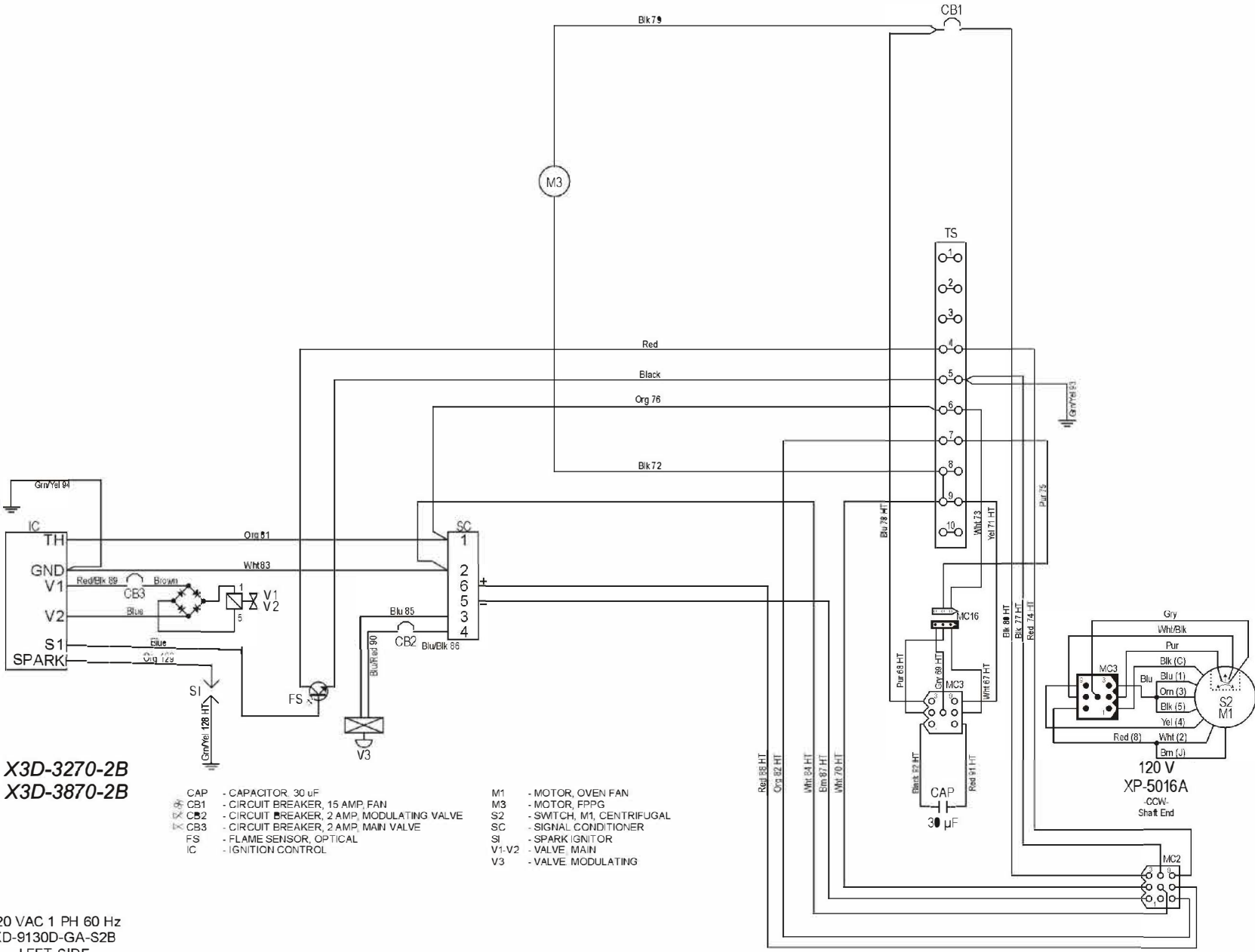

X3D-3270-2B
X3D-3870-2B

- | | | | |
|-----|---|--------|---------------------------|
| CAP | - CAPACITOR, 30 µF | M1 | - MOTOR, OVEN FAN |
| CB1 | - CIRCUIT BREAKER, 15 AMP FAN | M3 | - MOTOR, FPPC |
| CB2 | - CIRCUIT BREAKER, 2 AMP MODULATING VALVE | S2 | - SWITCH, M1, CENTRIFUGAL |
| CB3 | - CIRCUIT BREAKER, 2 AMP MAIN VALVE | SC | - SIGNAL CONDITIONER |
| FS | - FLAME SENSOR, OPTICAL | S1 | - SPARK IGNITOR |
| IC | - IGNITION CONTROL | V1, V2 | - VALVE MAIN |
| | | V3 | - VALVE MODULATING |

120 VAC 1 PH 60 Hz
XD-9130D-GA-S2B
LEFT SIDE
02/01/2013



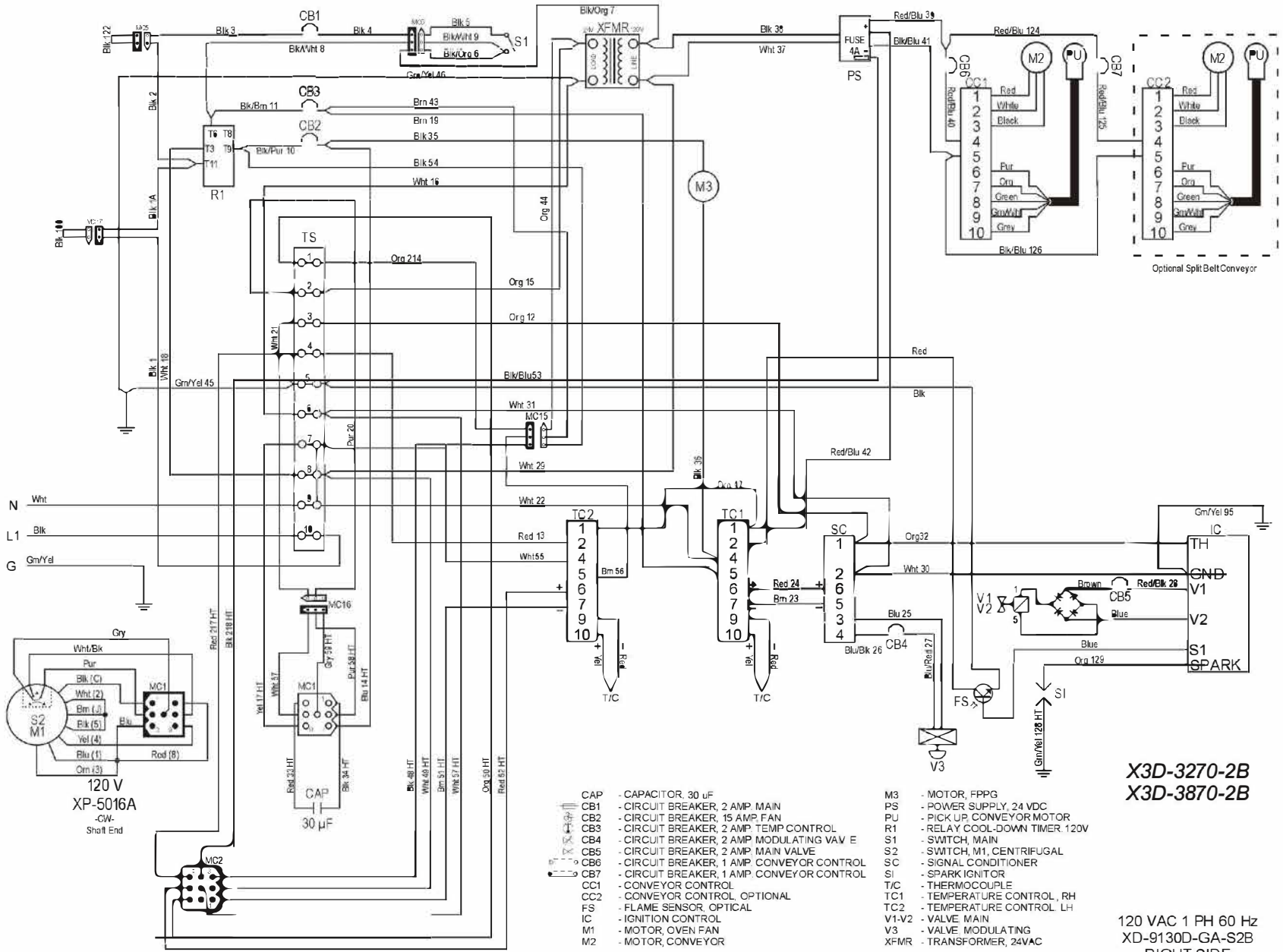

- CAP - CAPACITOR, 30 uF
- CB1 - CIRCUIT BREAKER, 2 AMP MAIN
- CB2 - CIRCUIT BREAKER, 15 AMP FAN
- CB3 - CIRCUIT BREAKER, 2 AMP TEMP CONTROL
- CB4 - CIRCUIT BREAKER, 2 AMP MODULATING VALVE
- CB5 - CIRCUIT BREAKER, 2 AMP MAIN VALVE
- CB6 - CIRCUIT BREAKER, 1 AMP CONVEYOR CONTROL
- CB7 - CIRCUIT BREAKER, 1 AMP CONVEYOR CONTROL
- CC1 - CONVEYOR CONTROL
- CC2 - CONVEYOR CONTROL, OPTIONAL
- CC3 - CONVEYOR CONTROL, OPTIONAL
- FS - FLAME SENSOR, OPTICAL
- IC - IGNITION CONTROL
- M1 - MOTOR, OVEN FAN
- M2 - MOTOR, CONVEYOR
- M3 - MOTOR, FPPG
- PS - POWER SUPPLY, 24 VDC
- PU - PICK UP CONVEYOR MOTOR
- R1 - RELAY COOL-DOWN TIMER 120V
- S1 - SWITCH, MAIN
- S2 - SWITCH, M1, CENTRIFUGAL
- SC - SIGNAL CONDITIONER
- SI - SPARK IGNITOR
- T/C - THERMOCOUPLE
- TC1 - TEMPERATURE CONTROL, RH
- TC2 - TEMPERATURE CONTROL, LH
- V1-V2 - VALVE MAIN
- V3 - MOTOR, VALVE MODULATING
- XFMR - TRANSFORMER, 24VAC

X3D-3270-2B
X3D-3870-2B

120 VAC 1 PH 60 Hz
XD-9130D-GA-S2B
RIGHT SIDE
02/01/2013

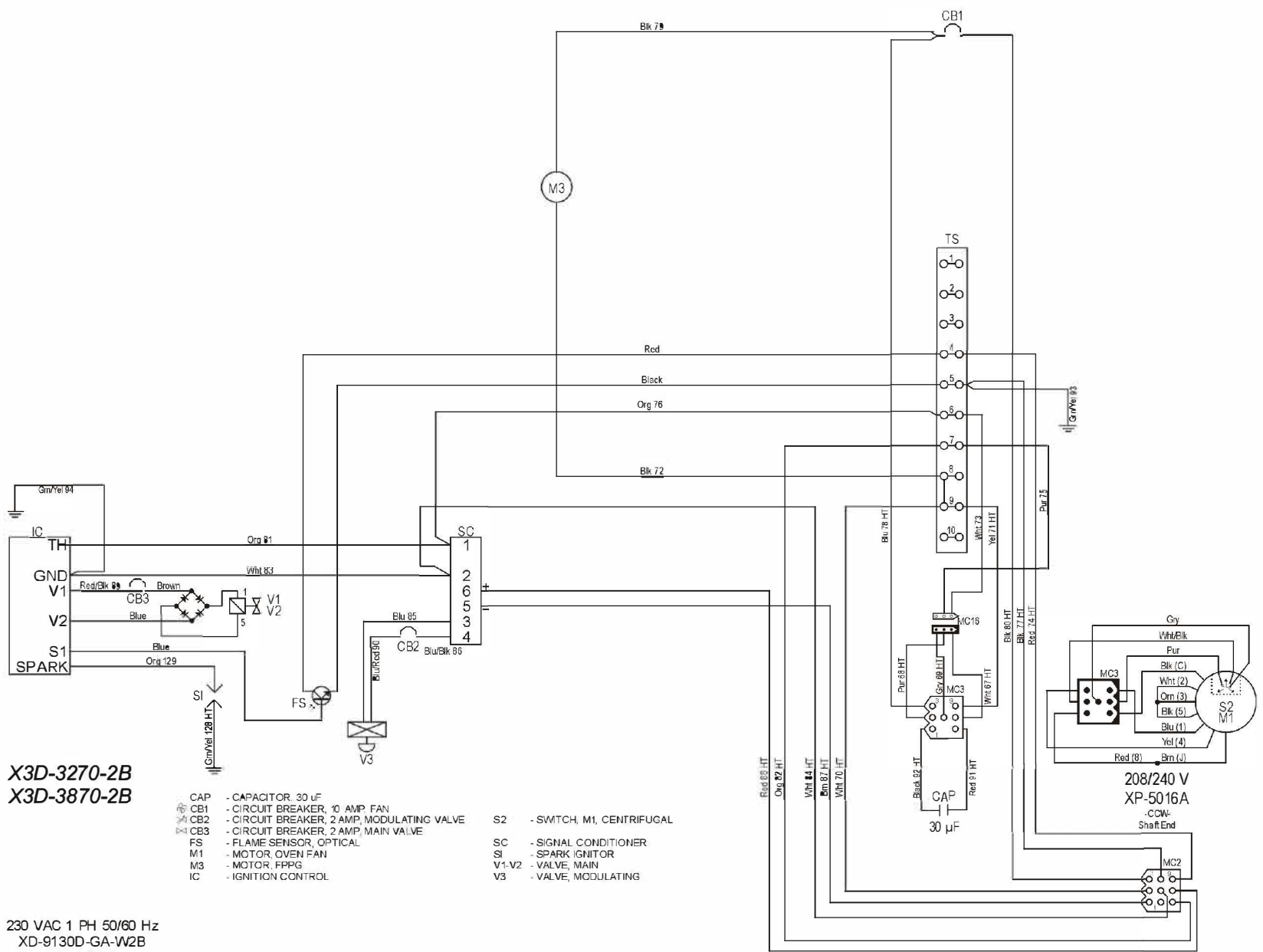

X3D-3270-2B
X3D-3870-2B

230 VAC 1 PH 50/60 Hz
XD-9130D-GA-W2B
LEFT SIDE
02/01/2013



Technical Support US: 888-443-2751



Technical Support INTL: 316-943-2751

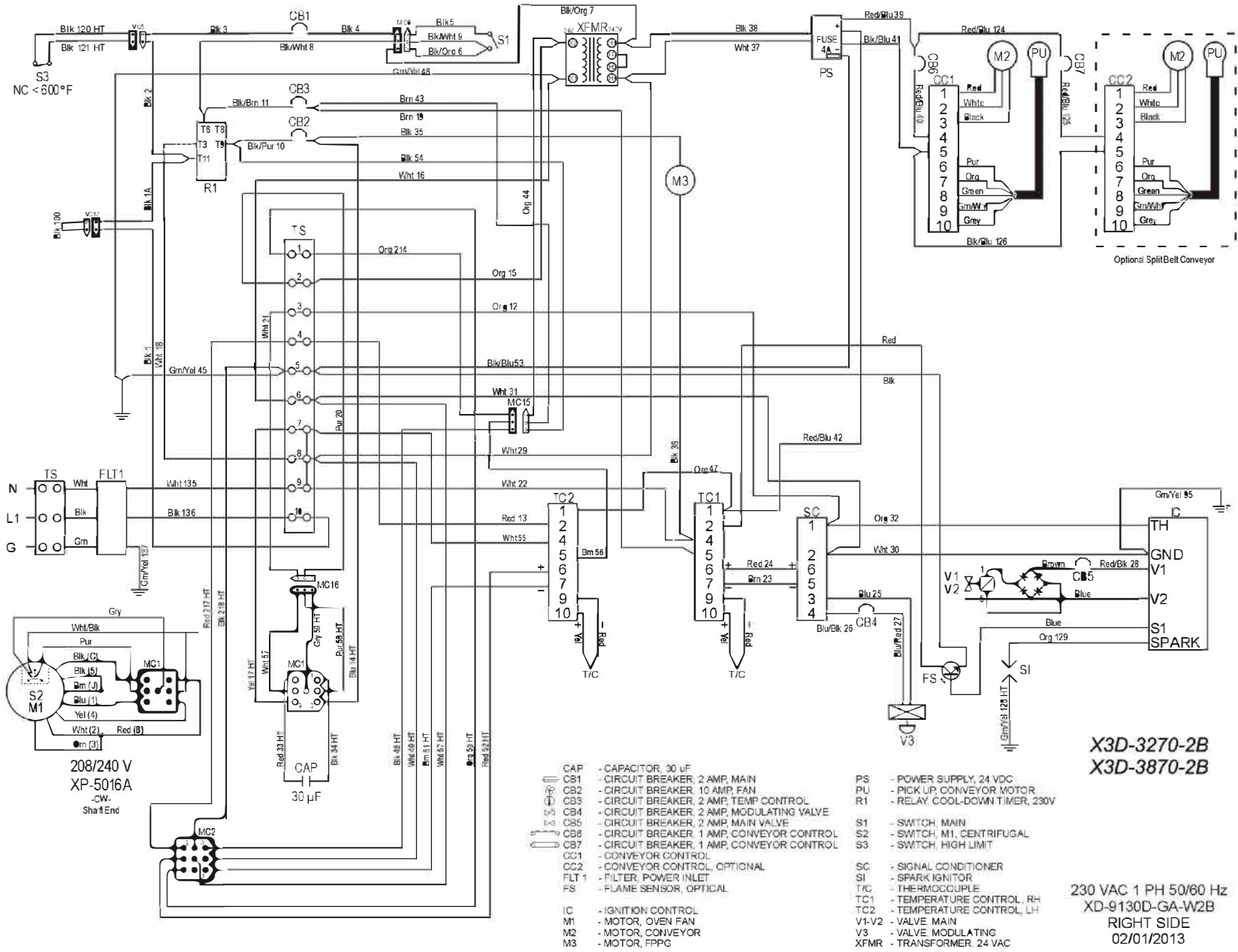

X3D-3270-2B
X3D-3870-2B

230 VAC 1 PH 50/60 Hz
XD-9130D-GA-W2B
RIGHT SIDE
02/01/2013

- CAP - CAPACITOR, 30 uF
- CB1 - CIRCUIT BREAKER, 2 AMP, MAIN
- CB2 - CIRCUIT BREAKER, 10 AMP, FAN
- CB3 - CIRCUIT BREAKER, 2 AMP, TEMP CONTROL
- CB4 - CIRCUIT BREAKER, 2 AMP, MODULATING VALVE
- CB5 - CIRCUIT BREAKER, 2 AMP, MAIN VALVE
- CB6 - CIRCUIT BREAKER, 1 AMP, CONVEYOR CONTROL
- CB7 - CIRCUIT BREAKER, 1 AMP, CONVEYOR CONTROL
- CC1 - CONVEYOR CONTROL
- CC2 - CONVEYOR CONTROL, OPTIONAL
- FLT 1 - FILTER, POWER INLET
- FS - FLAME SENSOR, OPTICAL
- IC - IGNITION CONTROL
- M1 - MOTOR, OVEN FAN
- M2 - MOTOR, CONVEYOR
- M3 - MOTOR, FPPG
- PS - POWER SUPPLY, 24 VDC
- PU - PICK UP, CONVEYOR MOTOR
- R1 - RELAY, COOL-DOWN TIMER, 230V
- S1 - SWITCH, MAIN
- S2 - SWITCH, M1, CENTRIFUGAL
- S3 - SWITCH, HIGH LIMIT
- SC - SIGNAL CONDITIONER
- SI - SPARK IGNITOR
- T/C - THERMOCOUPLE
- TC1 - TEMPERATURE CONTROL, RH
- TC2 - TEMPERATURE CONTROL, LH
- V1-V2 - VALVE MAIN
- V3 - VALVE, MODULATING
- XFMR - TRANSFORMER, 24 VAC

OVEN SCHEMATIC - WORLD & KOREA 2 BOX RH 230 VAC 65

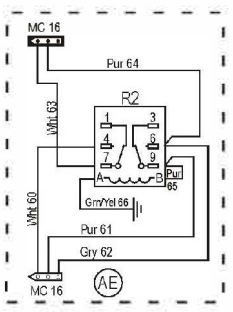
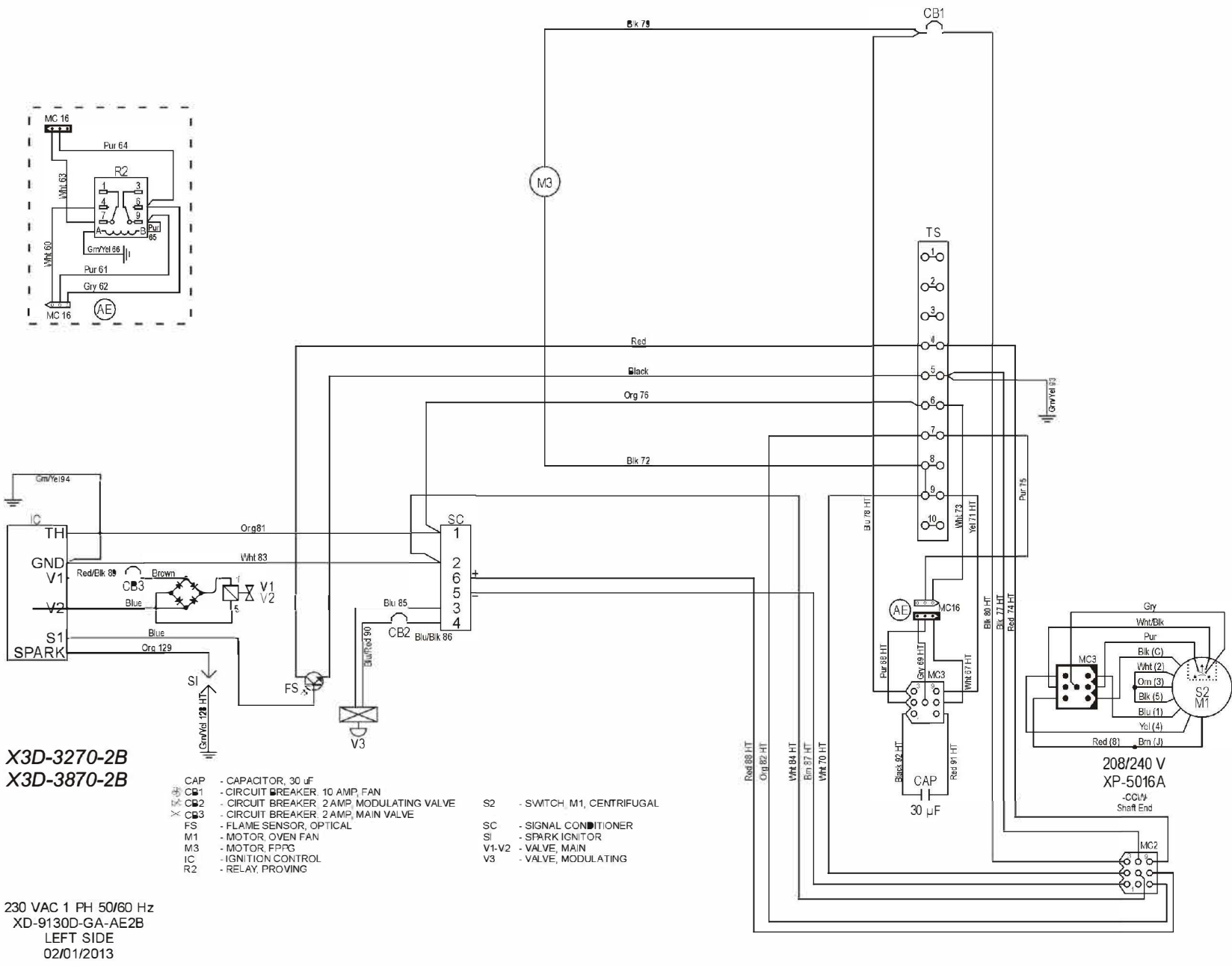

X3D-3270-2B
X3D-3870-2B

- CAP - CAPACITOR, 30 μF
- CB1 - CIRCUIT BREAKER 10 AMP, FAN
- CB2 - CIRCUIT BREAKER 2 AMP, MODULATING VALVE
- CB3 - CIRCUIT BREAKER 2 AMP, MAIN VALVE
- FS - FLAME SENSOR, OPTICAL
- M1 - MOTOR, OVEN FAN
- M3 - MOTOR, FPPG
- IC - IGNITION CONTROL
- R2 - RELAY, PROVING
- S2 - SWITCH, M1, CENTRIFUGAL
- SC - SIGNAL CONDITIONER
- SI - SPARK IGNITOR
- V1-V2 - VALVE, MAIN
- V3 - VALVE, MODULATING

230 VAC 1 PH 50/60 Hz
XD-9130D-GA-AE2B
LEFT SIDE
02/01/2013

Technical Support US: 888-443-2751



Technical Support INTL: 316-943-2751

Technical Support US: 888-443-2751



Technical Support INTL: 316-943-2751

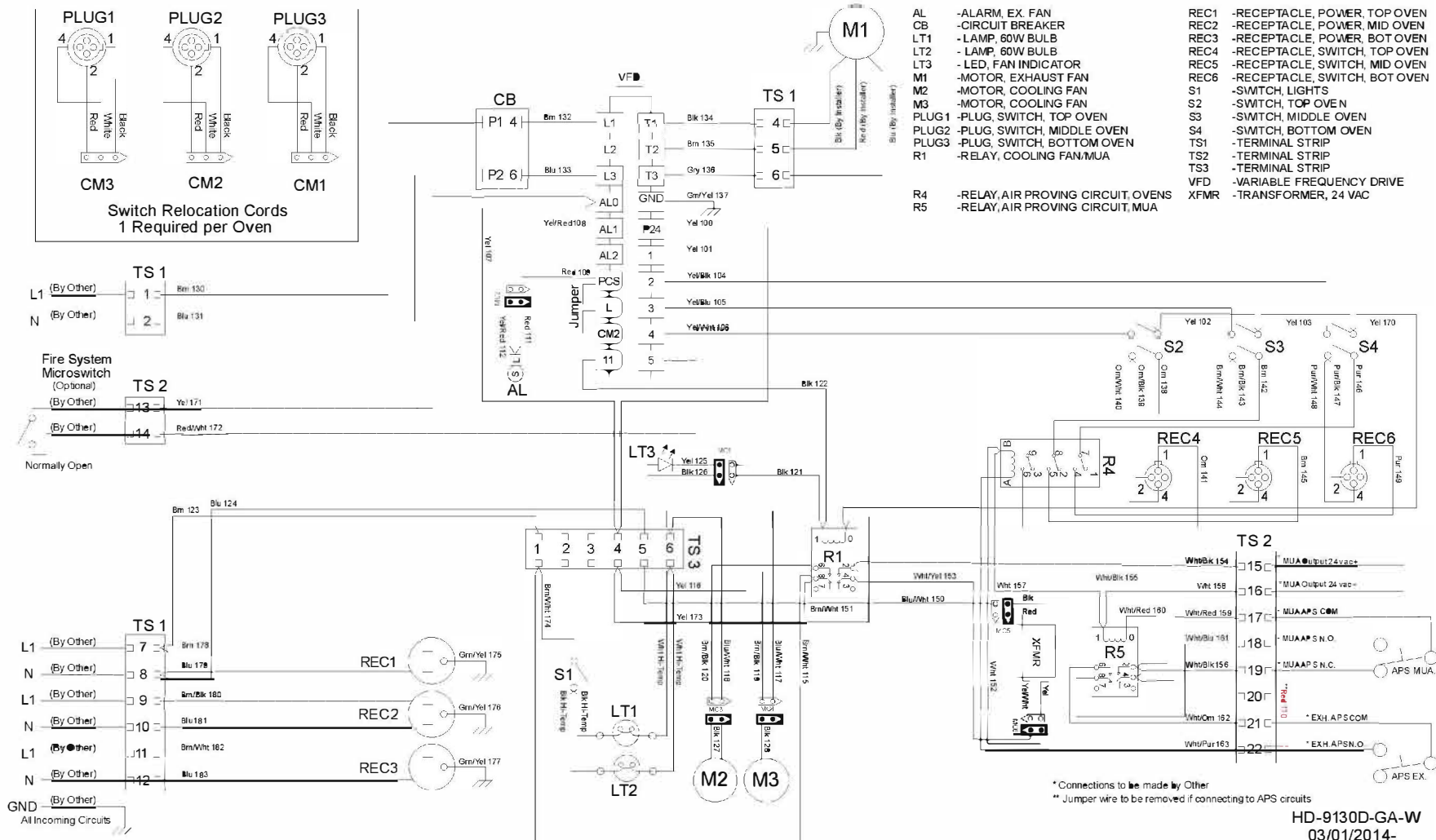

* Connections to be made by Other
 ** Jumper wire to be removed if connecting to APS circuits

HD-9130D-GA-W
03/01/2014-

Technical Support US: 888-443-2751



Technical Support INTL: 316-943-2751

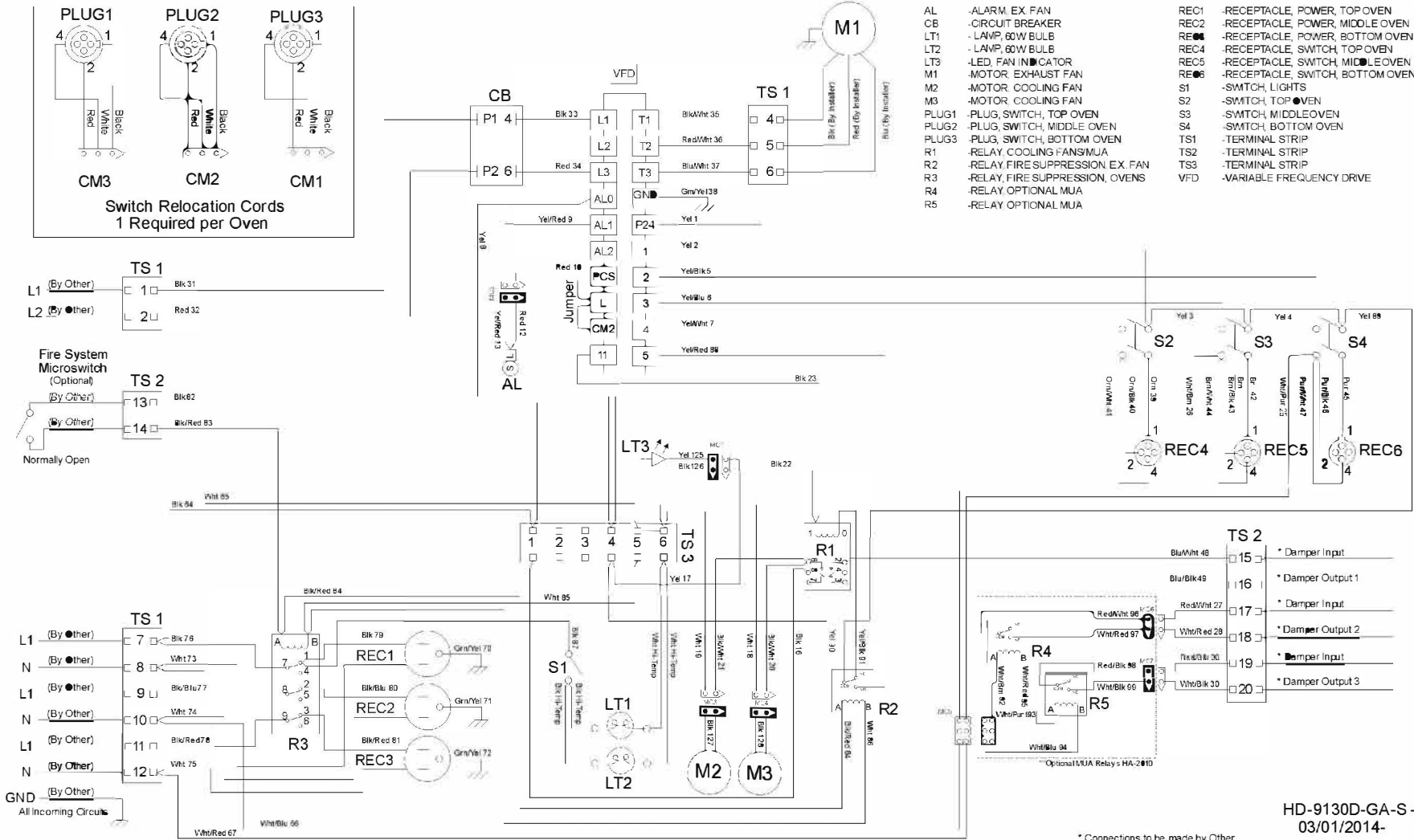

- AL - ALARM EX FAN
- CB - CIRCUIT BREAKER
- LT1 - LAMP 60W BULB
- LT2 - LAMP 60W BULB
- LT3 - LED FAN INDICATOR
- M1 - MOTOR EXHAUST FAN
- M2 - MOTOR COOLING FAN
- M3 - MOTOR COOLING FAN
- PLUG1 - PLUG SWITCH, TOP OVEN
- PLUG2 - PLUG SWITCH, MIDDLE OVEN
- PLUG3 - PLUG SWITCH, BOTTOM OVEN
- R1 - RELAY COOLING FANS/MUA
- R2 - RELAY FIRE SUPPRESSION EX. FAN
- R3 - RELAY FIRE SUPPRESSION, OVENS
- R4 - RELAY OPTIONAL MUA
- R5 - RELAY OPTIONAL MUA
- REC1 - RECEPTACLE, POWER, TOP OVEN
- REC2 - RECEPTACLE, POWER, MIDDLE OVEN
- REC3 - RECEPTACLE, POWER, BOTTOM OVEN
- REC4 - RECEPTACLE SWITCH, TOP OVEN
- REC5 - RECEPTACLE SWITCH, MIDDLE OVEN
- REC6 - RECEPTACLE SWITCH, BOTTOM OVEN
- S1 - SWITCH, LIGHTS
- S2 - SWITCH, TOP OVEN
- S3 - SWITCH, MIDDLE OVEN
- S4 - SWITCH, BOTTOM OVEN
- TS1 - TERMINAL STRIP
- TS2 - TERMINAL STRIP
- TS3 - TERMINAL STRIP
- VFD - VARIABLE FREQUENCY DRIVE

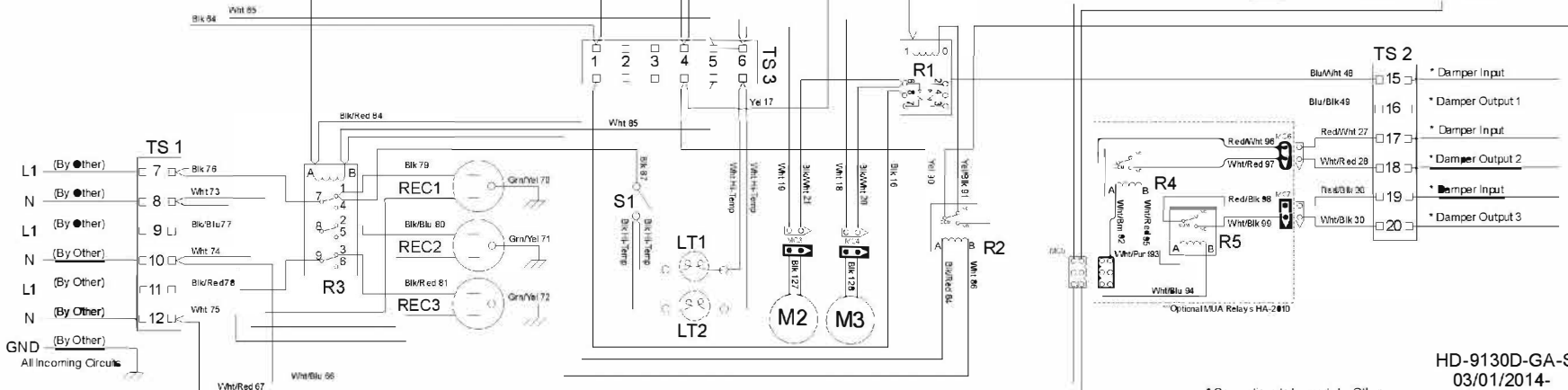
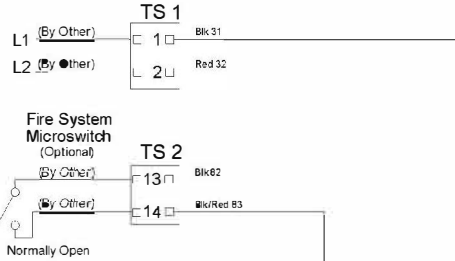
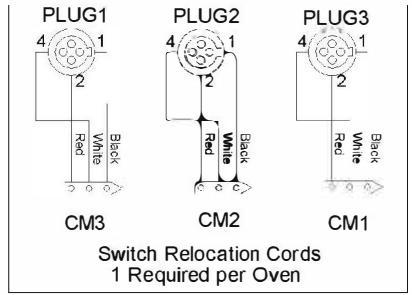

* Connections to be made by Other

HD-9130D-GA-S-FS
03/01/2014-

Technical Support US: 888-443-2751



Technical Support INTL: 316-943-2751

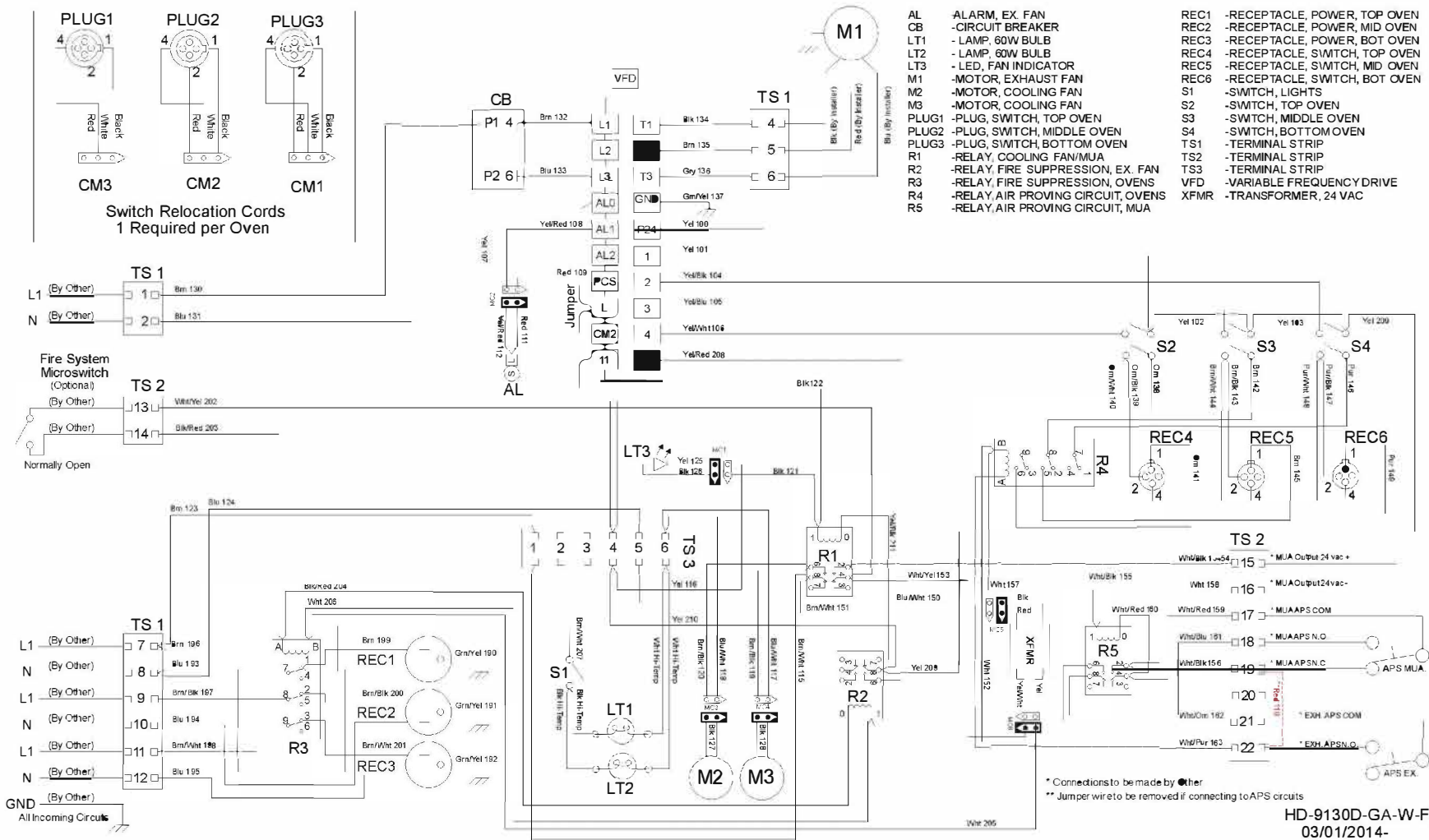

HD-9130D-GA-W-FS
03/01/2014-

- L1 - LAMP, 60W BULB
- L2 - LAMP, 60W BULB
- PLUG1- PLUG, SWITCH, TOPOVEN
- PLUG2- PLUG, SWITCH, MIDDLE OVEN
- PLUG3- PLUG, SWITCH, BOTTOM OVEN
- REC4 - RECEPTACLE, SWITCH, TOP OVEN
- REC5- RECEPTACLE, SWITCH, MIDDLE OVEN
- REC6- RECEPTACLE, SWITCH, BOTTOM OVEN
- S1 - SWITCH, LIGHTS
- S2 - SWITCH, TOP OVEN
- S3 - SWITCH, MIDDLE OVEN
- S4 - SWITCH, BOTTOM OVEN

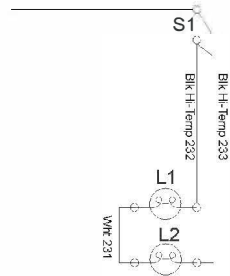
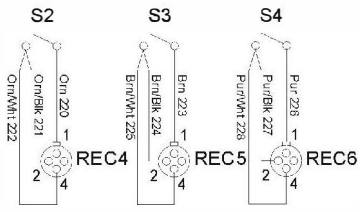

HD-9130D-NV
03/01/2014

This page intentionally left blank.

XLT Ovens
PO Box 9090
Wichita, Kansas 67277

US: 888-443-2751 FAX: 316-943-2769 INTL: 316-943-2751 WEB: www.xltovens.com