



MODEL 780/780-P

Circulating, heated air helps maintain food at the correct serving temperature for an extended period of time. It has the capability of accommodating a variety of food products such as cookies, wrapped sandwiches, burritos, pastries, and many more.

FEATURES:

- Acrylic display
- 780 - Includes "Ready to Go" graphic and 1.25" Channel graphics: HOT, FRESH, DELICIOUS
- 780-P - Includes "Ready to Go" pizza graphic and channel graphics: CHEESE, SAUSAGE, PEPPERONI, and DELUXE
- Heated, forced air
- Adjustable thermostat
- Temperature range to 170° F
- Overhead illumination
- Single rear door for product stocking
- 3 front opening doors for product removal
- Top & Middle racks: 9" x 14½"
- Bottom rack: 9" x 11"
- 4½" spacing between racks

ELECTRICAL DATA:

VOLTS:	120	AMPS:	5.4	WATTS:	650
---------------	-----	--------------	-----	---------------	-----

- Best when operated on an individual branch circuit
- 6' power cord length

DIMENSIONS:

- 9½"W x 16½"D x 21 ½"H

SHIPPING INFORMATION:

- **SHIPPING DIMENSIONS:** 15"W x 26"D x 25"H
- **SHIPPING WEIGHT:** 30 lbs.



IMPORTANT: Read the following safety and operation instructions to avoid injury and to avoid damage to equipment or property.

CAUTION: Unit light bulb may smoke upon initial start up. However, this does not cause a fire issue.



Plug unit into a properly grounded electrical outlet of the correct voltage, size, and plug configuration for this unit. We recommend usage on an individual branch circuit of at least 15 amps for best results. Failure to do so may result in decreased performance of the warmer.



Exterior surfaces on unit may get hot. Use caution when touching these areas to avoid injury.



Unplug warmer when not in use.



Only shatter resistant compact fluorescent light (CFL) bulbs which meet or exceed NSF Standards specifically designed for food holding units must be used. Breakage of bulbs not specially coated could result in personal injury and/or food contamination. Use of non-CFL bulbs may result in warping and/or melting of enclosure.

OPERATION:

EQUIPMENT SETUP

Once the unit has been taken out of the shipping carton and has been unpackaged, make sure that the light bulb is securely in its socket. Remove and discard any plastic film that may be on your unit protecting it from scratches during transit.

Before loading prepared food product into the warmer, you must preheat the unit for at least 30 minutes at a setting of 4 or 5 on the thermostat dial. After the preheat time has elapsed, you can then go ahead and place the previously prepared food product inside, and adjust the thermostat accordingly.

The amount of product placed in the warmer will affect the performance of the warmer. We suggest periodically checking the internal temperature of product and adjusting the temperature settings if necessary. Keep doors closed when not serving.

TEMPERATURE

This warmer is designed to maintain food product at or above the optimum temperature. It is not designed or intended to heat up or cook food to the serving temperature. Product is to be prepared to a temperature of above 160°F before placing in the warmer. Do not place product on its side as this will affect the internal holding temperatures of the product.

The following temperatures are **APPROXIMATE** and can vary due to unit location, electrical supply, product used, etc. *Intended as a guideline only.*

<u>SETTING</u>	<u>TEMPERATURE READING</u>
1	95° F
2	115° F
3	135° F
4	145° F
5	170° F

OPERATING INSTRUCTIONS

1. Plug unit in.
2. Before loading prepared food product into warmer, you must preheat the unit for 30 minutes at a setting of 4 or 5. After the preheat time has elapsed, place the previously prepared food product inside.
3. Set thermostat to desired level.



CAUTION: Racks get hot. Use hot pads/oven mitts when removing racks from the food warmer.

CLEANING AND MAINTENANCE:

CLEANING INSTRUCTIONS



Unplug unit from power source, and allow to cool completely before performing any maintenance or cleaning.



Unit is not waterproof. Do not submerge in water. Do not operate if unit has been submerged in water.



The use of any type of ammonia, alcohol, or chlorine based household cleaners will cause cracking of the doors/enclosure and is not covered under any warranty. Use warm soapy water and a soft cloth only.



Do not steam clean or use excessive water on unit to avoid personal injury or electrical shock.

It is recommended that the interior and exterior surfaces be cleaned daily with a mild soap and damp cloth. Stubborn stains on base of unit and/or racks may be removed with a non-abrasive cleaner and a damp cloth. Use of an abrasive cleanser could scratch or damage the finish of your unit.

1. Unplug unit from electrical supply
2. Let unit cool before cleaning
3. Clean with warm soapy water and a soft cloth only

REMOVE BLOWER OUTLET COVER

1. Open rear door
2. Pull back, and then lift cover off

REPLACE DISPLAY LIGHT BULB



Unplug unit from power source, and allow to cool completely before performing any maintenance or cleaning.



Only shatter resistant compact fluorescent light (CFL) bulbs which meet or exceed NSF Standards specifically designed for food holding units must be used. Breakage of bulbs not specially coated could result in personal injury and/or food contamination. Use of non-CFL bulbs may result in warping and/or melting of enclosure.

Use 20W MAX Teflon coated fluorescent bulb **ONLY**. **FAILURE TO DO SO WILL RESULT IN DAMAGE TO UNIT.** See parts list.

PARTS LIST:**MODEL 780**

ITEM #	PART #	DESCRIPTION
1	0021426	ENCLOSURE
2	0021438SK	FRONT DOOR SERVICE KIT (Incl. Hinges, nuts, screws, washers)
3	0019186	1-1/4" C-CHANNEL
4	0017379	HIGH LIMIT THERMOSTAT
5	0021441	UPPER/MIDDLE RACK
6	0021442	LOWER RACK
7	0022356	BLOWER MOTOR
8	0016447	550W @ 115V HEATING ELEMENT
9	0023040SK	BOTTOM FOOT SERVICE KIT
10	2162284001	POS SIGN HOLDER
11	0019172	20W FLUORESCENT LIGHT BULB
12	0016123	THERMOMETER
13	00486	POWER SWITCH
14	0017323	6-32 x 1/4 SCREW
15	0016800M	MALE HINGE
16	0016157	THERMOSTAT KNOB
17	0016180	STRAIN RELIEF
18	I013163	THERMOSTAT DIAL
19	0021456	THERMOSTAT
20	0019183	REAR DOOR ASSEMBLY
21	0018030	DOOR KNOB
22	0016133	#8-32 SCREW
23	0016144	MAGNETIC STRIP
24	0016800F	FEMALE HINGE
25	0016801	6-32 X 3/8 FHMS SCREW
26	0016181	POWER CORD

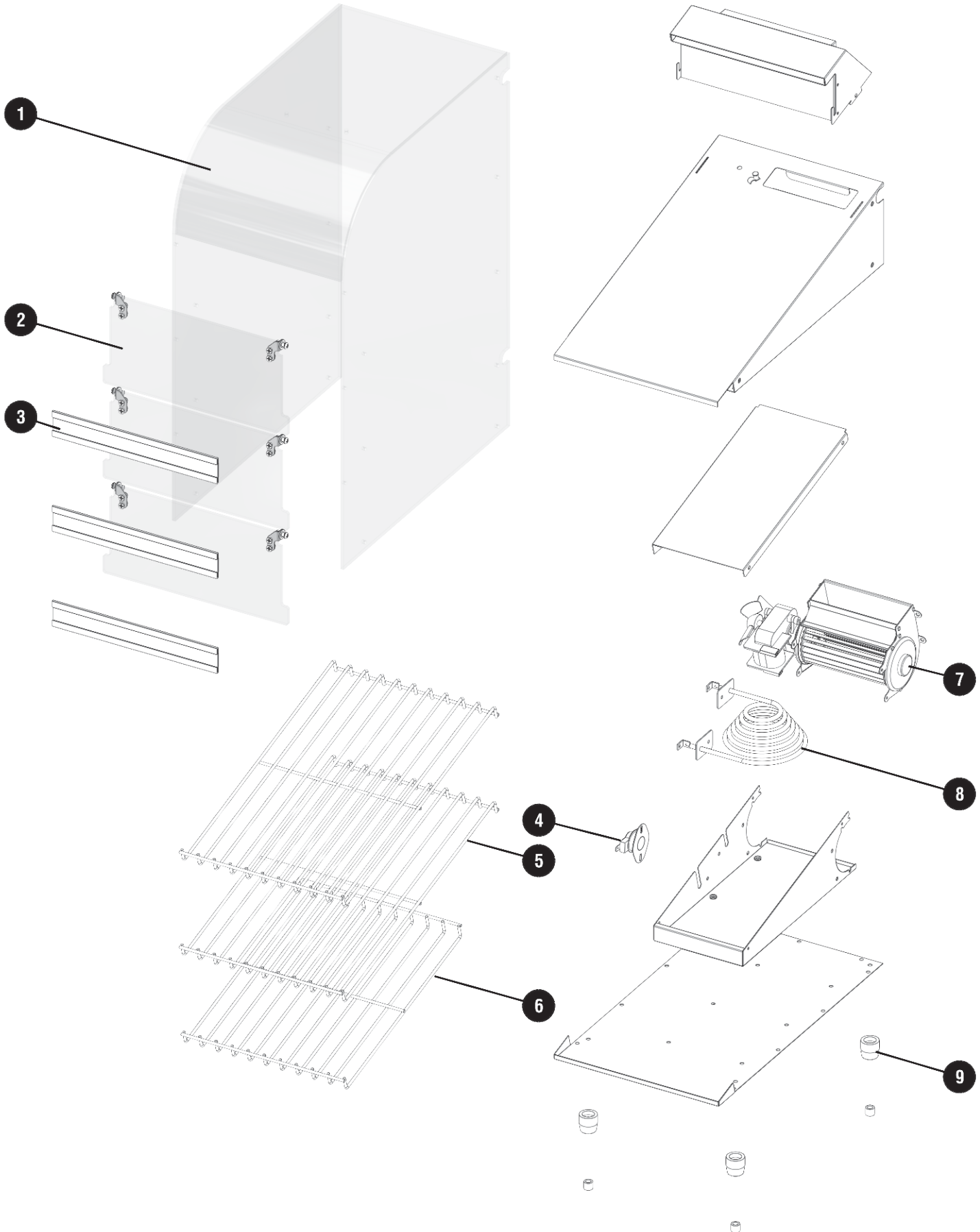

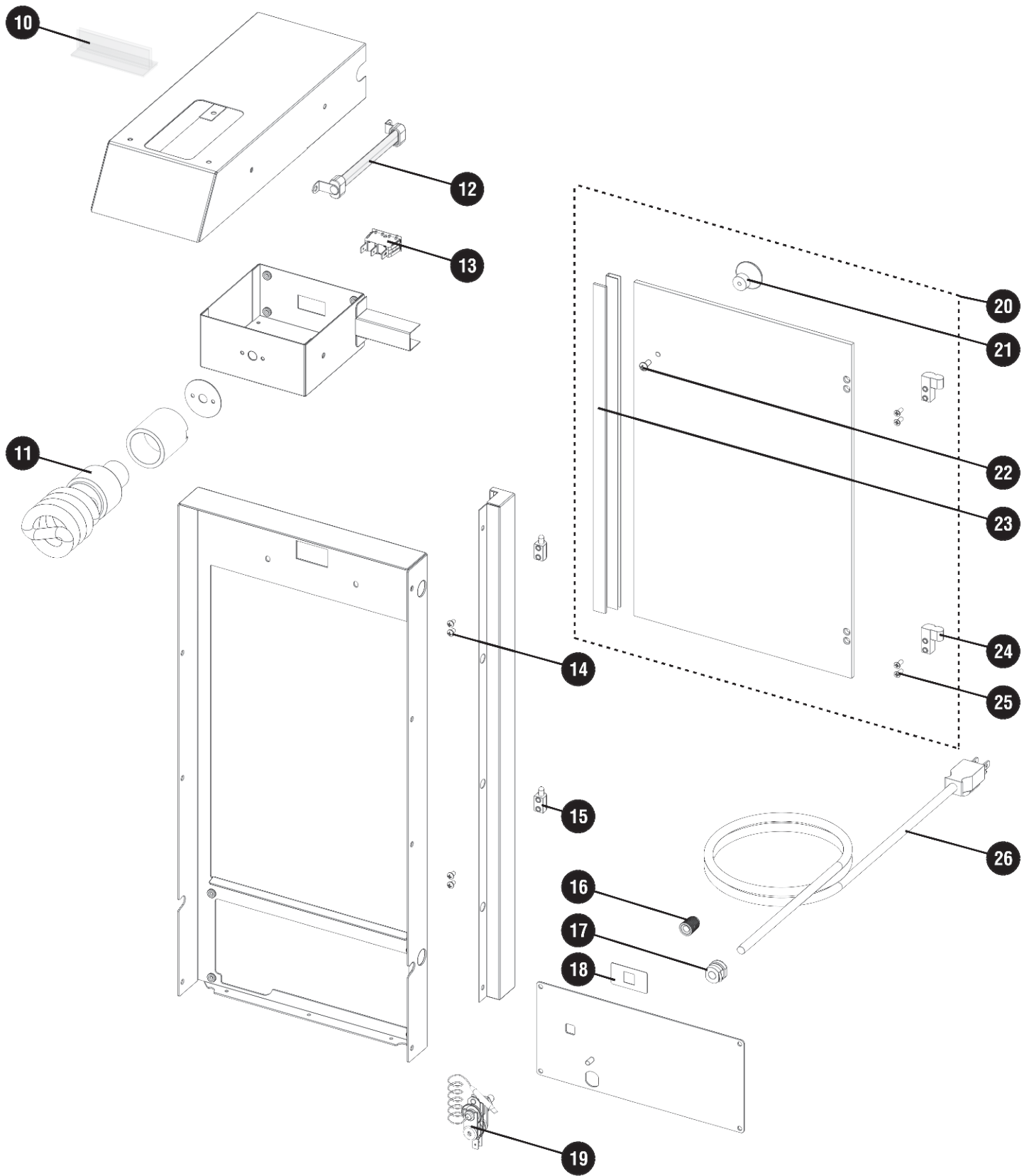

Model 780 Wiring Diagram

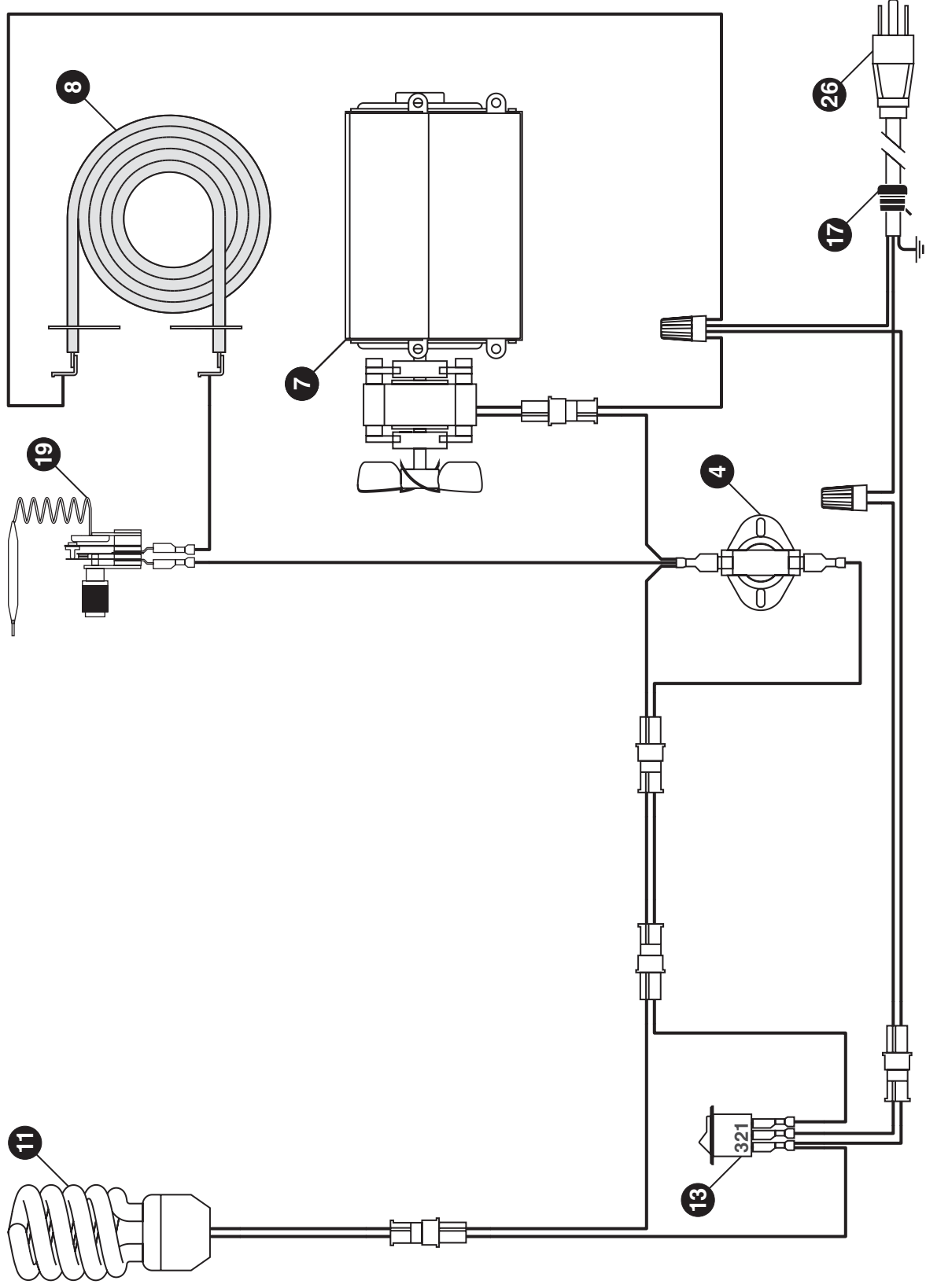

1 YEAR REPLACEMENT/EXCHANGE

Wisco Industries, Inc. warrants its equipment against defects in materials and workmanship subject to the following conditions:

Should any product fail to function in its intended manner under normal use within the limits defined in this warranty, Wisco Industries will determine if the item is to be repaired or replaced by Wisco Industries. Failure to follow authorizing instructions may void any claim and/or warranty.

* Contact Wisco Industries for repair/replacement by calling (608) 835-3106 or toll free (800) 999-4726.

You can also email us at: contact@wiscoind.com

* An authorizing RMA# must be obtained through Wisco Industries BEFORE any warranty issues can be resolved. Failure to do so in advance may void the warranty/claim resulting in Wisco Industries not being responsible for any incurred expenses and/or charges.

* At time of call Wisco Industries will assist you in:

- getting your unit replaced/exchanged
- and/or obtaining repair parts
- and/or authorizing a service agent

This warranty covers products shipped into the 48 contiguous United States, Hawaii, metropolitan areas of Alaska and Canada only. Warranty for international or areas not listed above will consist of replacement of parts only. There will be no labor coverage and parts must be shipped to an address within the 48 contiguous United States, Hawaii, metropolitan areas of Alaska and Canada only.

Time Period

One year from date of shipment from our manufacturing facility. Parts replaced under this warranty are warranted for the un-expired portion of the original product warranty only.

Exclusions

The following conditions are not covered by warranty:

- Equipment failure relating to improper installation and improper utility connection or supply.
- Equipment that has not been properly maintained or damage from improper cleaning and/or water damage to controls.
- Equipment that has not been used for its intended purpose or has been subject to misuse or misapplication, neglect, abuse, accident, alteration, negligence, damage during subsequent transit, delivery or installation, fire, flood, riot or act of god.
- Equipment that has the model number or serial number removed or altered.

WISCO INDUSTRIES, INC. DISCLAIMS AND EXCLUDES ANY AND ALL OTHER EXPRESS OR IMPLIED WARRANTIES, INCLUDING WITHOUT LIMITATION, ANY AND ALL WARRANTIES OF MERCHANTABILITY OR FITNESS FOR A PARTICULAR PURPOSE.

Buyer agrees that its SOLE AND EXCLUSIVE REMEDY against Wisco and Wisco's SOLE AND EXCLUSIVE LIABILITY arising out of any defect or nonconformity in the product shall be replacement/exchange of such nonconforming countertop food service equipment at Wisco's expense. No countertop food service equipment shall be returned without Wisco's consent. IT IS AGREED THAT WISCO'S MAXIMUM LIABILITY SHALL NOT IN ANY CASE EXCEED THE SALE PRICE FOR THE COUNTERTOP EQUIPMENT CLAIMED TO BE DEFECTIVE OR NONCONFORMING.

Without limiting the generality of the foregoing, SUCH WARRANTIES DO NOT COVER: Glass, plastic enclosures/panels, door assemblies, hardware, light bulbs & wire pizza oven heating elements.

SHIPPING DAMAGE

If the outside packaging of your order is visibly dented, crushed, torn or otherwise significantly damaged, or if you move the carton and you hear broken glass, please reject the shipment while driver is still with you if possible. Please call us at (800) 999-4726 or email contact@wiscoind.com to notify us of the issue. We will confirm the damage with the carrier and re-ship your order immediately.

RETURN POLICY

You may return any unused, undamaged items within 30 days of receipt. We will issue a refund in the form of your original payment, less a 20% re-stock fee. All returns must be received in resalable condition. Wisco Industries will not accept a return with shipping damage. Wisco Industries will not reimburse any shipping and handling fees.

If you would like to return an item please call us at 608-835-3106 or toll free at 1-800-999-4726 and ask for our Food Service Equipment Division or you may send an email to us at: contact@wiscoind.com. You will be given a return # and return instructions. We can not accept returns without a return #. Please be sure to include a copy of the packing list with the return.