

# SOUP WARMER/WARMING KETTLE



## MODEL 768

This soup/food warmer is designed for high performance that is perfect for re-thermalizing refrigerated soups, stews and more. With a thermostatically controlled heating system, it provides maximum heat up and recovery.

### FEATURES:

- Exterior/Interior stainless steel construction
- 7 quart capacity (6.6 L)
- Fully adjustable thermostat from room temp to over 210° F.
- Insulated vessel to help maintain product consistency and stop counter top heat build up
- Warming Kettle is



### ITEMS INCLUDED:

- Stainless Steel Product Insert #0016870
- Hinged Cover #0016850
- Product Riser; to keep food products such as tamales off of the insert bottom

### Electrical:

120 volts, 8.3 amps, 1000 watts

5 foot power cord

\*Recommend usage on an individual branch circuit

### Unit Dimensions (does not reflect shipping dimension):

14" H x 11" Diameter (fully assembled w/insert & lid)

### Actual Weight: (does not reflect shipping weight):

10 lbs.

### AVAILABLE ACCESSORIES:

- 4 oz. Ladle #0016869
- Stainless Steel Product Insert #0016870
- Hinged Cover #0016850



An ISO 9001 Company

## **WISCO INDUSTRIES®**





P.O. BOX #10  
OREGON, WI 53575  
PHONE: 608-835-3106  
FAX: 608-835-8273  
www.wiscoind.com

### LIMITED WARRANTY:

Wisco Industries, Inc. expressly warrants the product will be free from defects in workmanship and materials for a period of 1 year from the date of shipment. WISCO DISCLAIMS AND EXCLUDES ANY AND ALL OTHER EXPRESS OR IMPLIED WARRANTIES, INCLUDING WITHOUT LIMITATION, ANY AND ALL WARRANTIES OF MERCHANTABILITY OR FITNESS FOR A PARTICULAR PURPOSE.

Buyer agrees that its SOLE AND EXCLUSIVE REMEDY against Wisco and Wisco's SOLE AND EXCLUSIVE LIABILITY arising out of any defect or nonconformity in the product shall be replacement/exchange of such nonconforming countertop food service equipment at Wisco's expense. No countertop food service equipment shall be returned without Wisco's consent. IT IS AGREED THAT WISCO'S MAXIMUM LIABILITY SHALL NOT IN ANY CASE EXCEED THE SALE PRICE FOR THE COUNTERTOP EQUIPMENT CLAIMED TO BE DEFECTIVE OR NONCONFORMING.

**IMPORTANT:** Read the following safety and operation instructions to avoid injury and to avoid damage to equipment or property.

-  Plug unit into a properly grounded electrical outlet of the correct voltage, size and plug configuration for this unit. We recommend usage on an individual branch circuit of at least 15 amps for best results. Failure to do so may result in decreased performance of the warmer.
-  Unplug unit from power source and allow to cool completely before performing any maintenance or cleaning.
-  Warming Vessel is not waterproof. Do Not submerge in water. Do not operate if unit has been submerged in water.
-  Exterior surfaces on unit may get hot. Use caution when touching these areas to avoid injury.

EQUIPMENT SET UP & OPERATION :

- Always clean equipment thoroughly before first use.
- Do not place food product directly into warming vessel. ALWAYS use the product insert provided.
- Add no more than 22 ounces of water to warming vessel. Do not use cold water. Temperature of water will affect heat up time of food product.
- Turn thermostat to 10 and preheat for approximately 10 minutes.
- Place covered insert with food product into warming vessel.
- Stir frequently and adjust temperature accordingly. If product placed in insert was refrigerated it will take longer to heat up.
- The amount of product in the food insert will affect the performance of the warmer. We suggest periodically checking the internal temperature of product and adjusting the temperature settings if necessary.
- Keep food product covered to maintain ideal serving temperature.
- Always refrigerate any remaining food product

The following temperatures are **APPROXIMATE** and can vary due to unit location, electrical supply, product used, etc. *\*Intended as a guideline only.*

<u>SETTING</u>	<u>THERMOMETER READING</u>
1	Room Temp.
2	Room Temp.
3	90° F
4	120° F
5	150° F
6	170° F
7	180° F
8	190° F
9	200° F
10	210° F

CLEANING INSTRUCTIONS:

 Unplug unit from power source and allow to cool completely before performing any maintenance or cleaning.

 Warming vessel is not waterproof. Do Not submerge in water. Do not operate if unit has been submerged in water.

- It is recommended that the interior and exterior surfaces be cleaned daily with a mild soap and damp cloth.
- NEVER POUR COLD WATER INTO DRY HEATED UNITS.
- Stubborn stains/water scale may be removed with a mild cleanser and damp cloth or PLASTIC scouring pad. Usage of an abrasive cleanser could scratch or damage the finish of your unit.
- Do not use chlorides or chloride based products on this unit.  
Use of such products and/or improper cleaning may cause corrosion and pitting.

FAILURE TO COMPLY WITH THESE INSTRUCTIONS MAY VOID UNIT WARRANTY.

TROUBLESHOOTING:

 Unplug unit from power source and allow to cool completely before performing any maintenance or cleaning.

Unit not working:

- Unit plugged in and/or power cord has not been damaged
- Check that thermostat/unit has been turned on
- Check circuit breaker

Unit not heating properly:

- Have you allowed enough time for proper heating up of food product?
- Check heat settings. Is it at the correct setting for your food product?

NOTES:

---

---

---

---

---

---

---

---

---

---

If you have further questions in regards to this piece of equipment - please contact Wisco Industries, Inc. Directly at: (608)835-3106 or (800)999-4726; fax (608)835-8273 for further information.

\*Please be sure to have the complete model # and serial # available.

# Model 768 - Exploded View / Wiring Diagram

## Exploded View

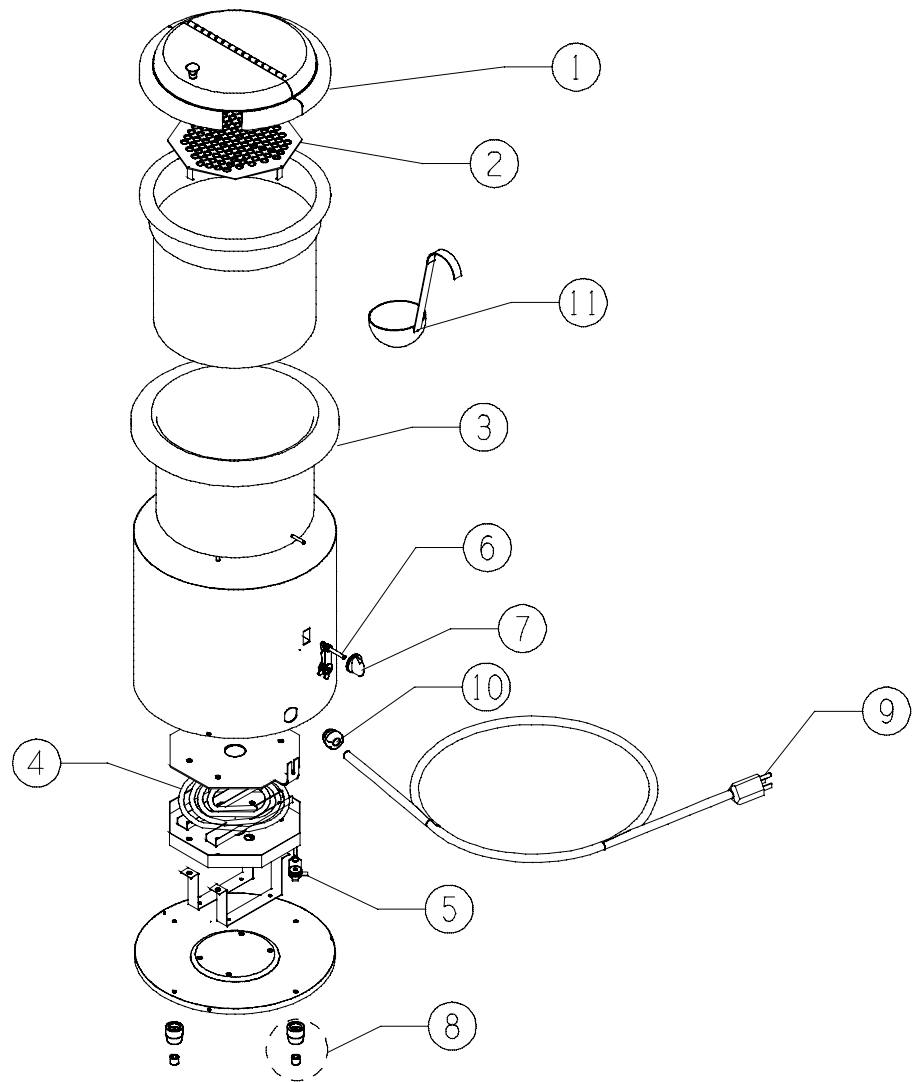

## Wiring Diagram

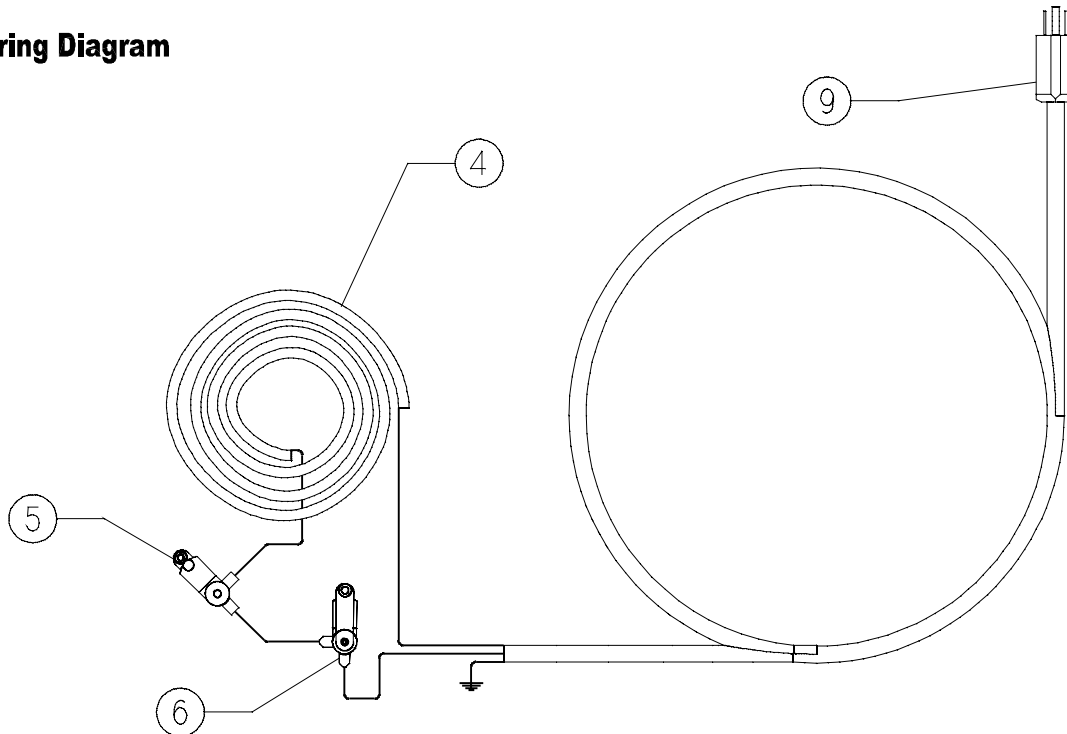

**MODEL 768**

<b><u>ITEM #</u></b>	<b><u>PART #</u></b>	<b><u>DESCRIPTION</u></b>
1	0016850	HINGED COVER
2	0016851	PRODUCT RISER – No longer available
3	0016870	COOKWELL
4	0016854	1000W HEATING ELEMENT – No longer available
5	0016857	HI-LIMIT THERMOSTAT
6	0016859	ADJUSTABLE THERMOSTAT
7	0016860	THERMOSTAT KNOB – No longer available
8	0023057SK	BOTTOM FOOT SERVICE KIT
9	0016181	POWER CORD
10	0016180	STRAIN RELIEF
11	0016869	4 OZ LADLE



An ISO 9001 Company

**WISCO INDUSTRIES, INC.**  
P.O. BOX 10 OREGON, WI 53575  
TELEPHONE (608)835-3106/(800)999-4726 FAX (608)835/8273

## WARRANTY INFORMATION

### \* 1 YEAR REPLACEMENT/EXCHANGE \*

If you should experience any mechanical difficulties with your Wisco Industries, Inc. manufactured unit during the 1 year warranty time period please do the following:

- \* Contact Wisco Industries, Inc. for repair/replacement by calling (608)835-3106 or Toll Free (800)999-4726.
- \* Please have your **MODEL #** and **SERIAL #** available. These numbers can be found on a black decal located on the lower side of the unit. There is also a date of manufacturing that can be found on the bottom of the unit.
- \* At that time, we can assist you in:
  - getting your unit replaced/exchanged
  - and/or obtaining repair parts
  - and/or authorizing a service agent
- \*\* Please note that you **MUST** contact Wisco Industries, Inc. and obtain a RMA# **BEFORE** any warranty issues can be resolved. **Failure to do so may void the warranty/claim resulting in Wisco Industries, Inc. not being responsible for any incurred expenses and/or charges.**

#### LIMITED WARRANTY:

Wisco Industries, Inc. expressly warrants the product will be free from defects in workmanship and materials for a period of 1 year from the date of shipment. WISCO DISCLAIMS AND EXCLUDES ANY AND ALL OTHER EXPRESS OR IMPLIED WARRANTIES, INCLUDING WITHOUT LIMITATION, ANY AND ALL WARRANTIES OF MERCHANTABILITY OR FITNESS FOR A PARTICULAR PURPOSE.

Buyer agrees that its **SOLE AND EXCLUSIVE REMEDY** against Wisco and Wisco's **SOLE AND EXCLUSIVE LIABILITY** arising out of any defect or nonconformity in the product shall be replacement/exchange of such nonconforming countertop food service equipment at Wisco's expense. No countertop food service equipment shall be returned without Wisco's consent. **IT IS AGREED THAT WISCO'S MAXIMUM LIABILITY SHALL NOT IN ANY CASE EXCEED THE SALE PRICE FOR THE COUNTERTOP EQUIPMENT CLAIMED TO BE DEFECTIVE OR NONCONFORMING.**