

MODEL 680-1 (Single Door)

MODEL 680-2 (2 Door pass through)

This warmer provides bottom heat to keep crusts crisp. The illuminated shelves are thermostatically controlled to provide temperature flexibility. Also ideal for holding cookies, biscuits, muffins and other foods at proper serving temperatures.

FEATURES:

- Red hood with pizza pictured "Ready To Go" graphic panels (#1013757)
- Adjustable thermostat
- Temperatures from 80°F to above 150°F
- 2 heated, illuminated shelves
- Each shelf accommodates up to a 16" pizza
- Optional racks available (1 per shelf)
FLAT (#0016777) or
3/4" RAISED (#0016289)
- Great for placing on top of the Wisco Model 560 pizza oven for a space saving feature

ELECTRICAL DATA:

VOLTS:	120	AMPS:	2.1	WATTS:	260
---------------	-----	--------------	-----	---------------	-----

- Best when operated on an individual branch circuit
- 5' power cord length

DIMENSIONS:

Outside: 24"H x 18"W x 18"D
 Inside: 13-1/2"H x 17"W x 17"D

SHIPPING INFORMATION:

SHIPPING DIMENSIONS: 24"L x 24"W x 32"H
SHIPPING WEIGHT: 37 lbs.



IMPORTANT: Read the following safety and operation instructions to avoid injury and to avoid damage to equipment or property.



Plug unit into a properly grounded electrical outlet of the correct voltage, size and plug configuration for this unit. We recommend usage on an individual branch circuit of at least 15 amps for best results. Failure to do so may result in decreased performance of the warmer.



Only shatter resistant light bulbs which meet or exceed NSF Standards specifically designed for food holding units must be used. Breakage of bulbs not specially coated could result in personal injury and/or food contamination.



Exterior surfaces on unit may get hot. Use caution when touching these areas to avoid injury.



Unplug oven when not in use

EQUIPMENT SET UP

Once the unit has been taken out of the shipping carton and has been unpackaged, check to make sure that all light bulbs are securely in their sockets.

CLEANING INSTRUCTIONS



Unit is not waterproof. Do Not submerge in water. Do not operate if unit has been submerged in water.



Unplug unit from power source and allow to cool completely before performing any maintenance or cleaning.



The use of any type of ammonia, alcohol or chlorine based household cleaners will cause cracking of the door/enclosure and is not covered under any warranty. Use warm soapy water and a soft cloth only.

It is recommended that the interior and exterior surfaces be cleaned daily with a mild soap and damp cloth. Stubborn stains on base of unit and/or shelves may be removed with a non-abrasive cleaner and a damp cloth. Usage of an abrasive cleanser could scratch or damage the finish of your unit.

STEP 1: Unplug unit from electrical supply

STEP 2: Let unit cool before cleaning

STEP 3: Clean with warm soapy water and a soft cloth only

TO REPLACE DISPLAY LIGHT & SHELF BULBS



Only shatter resistant light bulbs which meet or exceed NSF Standards specifically designed for food holding units must be used. Breakage of bulbs not specially coated could result in personal injury and/or food contamination.

Disconnect the power supply and wait until unit has cooled completely before replacing any lights or bulbs.

OPERATION:

This warmer is designed to maintain food product at or above the optimum temperature. It is not designed or intended to heat up or cook food to the serving temperature. Product is to be prepared to a temperature of above 160°F before placing in the warmer. Do not place product on its side as this will affect the internal holding temperatures of the product.

TEMPERATURE

The amount of product placed in the warmer will affect the performance of the warmer. We suggest periodically checking the internal temperature of the product and adjusting the temperature settings if necessary. Keep door(s) closed when not serving.

The following temperatures are *APPROXIMATE* and can vary due to unit location, electrical supply, product used, etc. **Intended as a guideline only.*

<u>SETTING</u>	<u>THERMOMETER READING</u>
1	85° F
2	105° F
3	140° F
4	165° F
5	Above 190° F

OPERATING INSTRUCTIONS

1. Plug unit in.
2. Before loading prepared food product into warmer, you must preheat the unit for 30 minutes at a setting of 4 or 5 on the thermostat dial. After the preheat time has elapsed you can then go ahead and place the previously prepared food product inside.
3. Set thermostat to desired level.

* Pizza should be placed on a standard aluminum pizza pan and not directly on the warmer shelf. This will keep product from drying out for a longer period of time and will also help keep the cabinet cleaner.

* When placing your product on pizza pans we recommend a setting of 4 or 5. Settings vary depending on product weight, consistency and personal preference.



CAUTION: Pans get hot. Use hot pads/oven mitts when removing pans from the food warmer.

NOTES:

PARTS LIST:

MODEL 680-1

<u>ITEM #</u>	<u>PART #</u>	<u>DESCRIPTION</u>
1	0016130	RED CANOPY
2	0016129	CUP WASHERS
3	0016128	HOOD SCREWS
4	0016135-1S	ENCLOSURE SERVICE KIT
5	0017265	TUFFSKIN INCANDESCENT LAMP
6	0017264	LIGHT SOCKET
7	0016161T	COATED BULB 15W
8	0016134-17	LIGHT SOCKET - BAYONET STYLE
9	0016181	POWER CORD
10	0016180	STRAIN RELIEF
11	00486	ON/OFF SWITCH
12	0016190	THERMOSTAT
13	0016157	THERMOSTAT KNOB
14	I013163	THERMOSTAT DIAL
15	0023040SK	FOOT SERVICE KIT (Incl. Foot, screw, washer, insert & t-nut)
16	0016133	#8-32 SCREW
17	0016144	MAGNETIC STRIP
18	0018030	BLACK DOOR KNOB
19	0016136	#8-32 ACORN NUT
20	0016142	MALE HINGE
21	0016353-BLK	BACK DOOR - BLACK KNOB (CONTROL SIDE)
22	0016141	FEMALE HINGE
23	0016123	THERMOMETER
24	0016138	100W 120V UPPER ELEMENT
25	0016120	118W 120V LOWER ELEMENT
*	I013756	RED "READY TO GO" DECAL 680/690
*	I013757	PIZZA "READY TO GO" DECAL 680/690
*	0016777	FLAT RACK (PANS OR BOXES)
*	0016289	3/4" RAISED RACK
*	0016329	DUMMY PLUG

Model 680-1 Exploded View

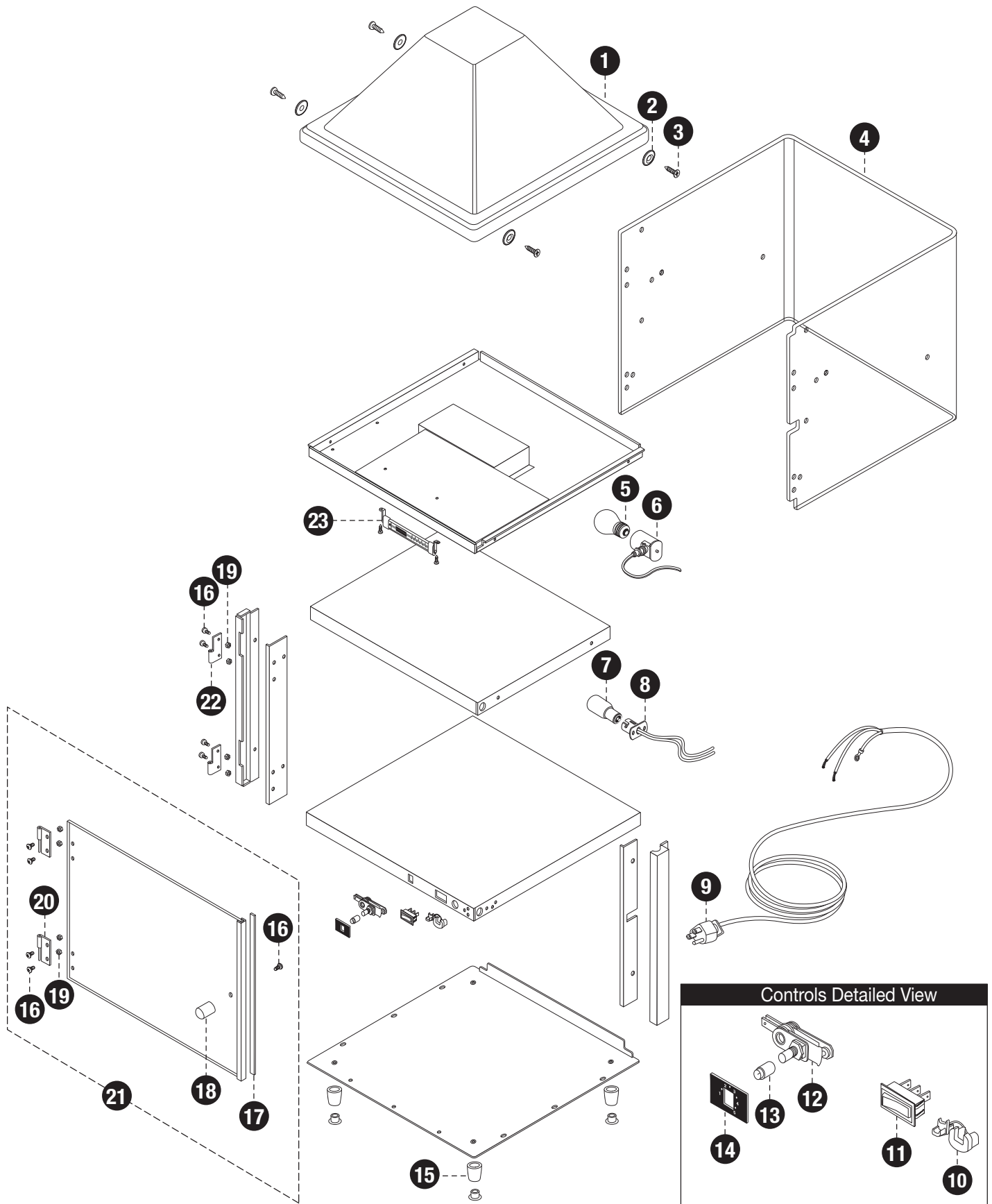

Model 680-1 Wiring Diagram

Current Model (Single Switch)

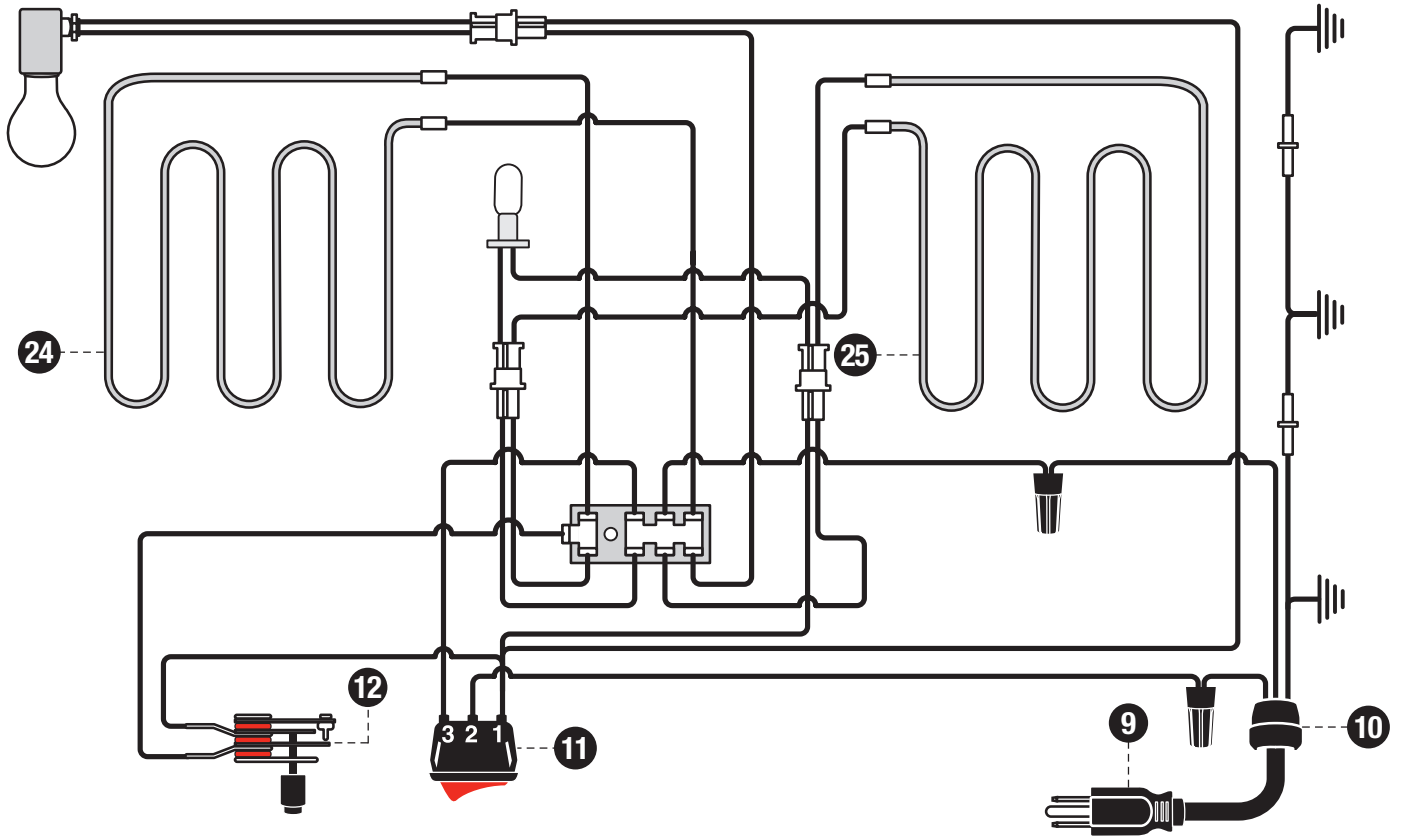

Obsolete Model (Dual Switch)

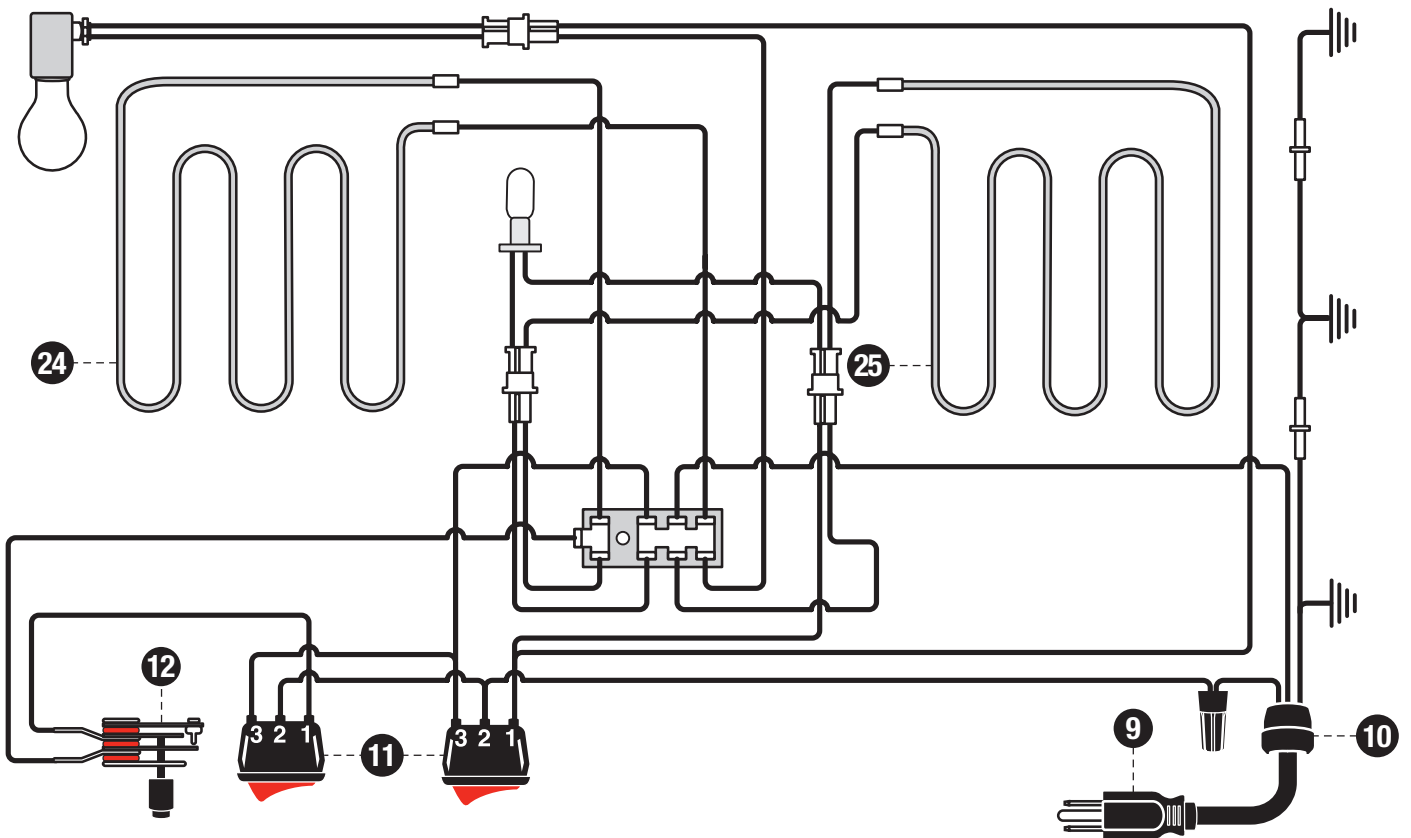

PARTS LIST:**MODEL 680-2**

<u>ITEM #</u>	<u>PART #</u>	<u>DESCRIPTION</u>
1	0016130	RED CANOPY
2	0016129	CUP WASHERS
3	0016128	HOOD SCREWS
4	0016199	ENCLOSURE
5	0016352	FRONT DOOR
6	0017265	TUFFSKIN INCANDESCENT LAMP
7	0017264	LIGHT SOCKET
8	0016161T	COATED BULB 15W
9	0016134-17	LIGHT SOCKET - BAYONET STYLE
10	0016181	POWER CORD
11	0016180	STRAIN RELIEF
12	00486	ON/OFF SWITCH
13	0016190	THERMOSTAT
14	0016157	THERMOSTAT KNOB
15	I013163	THERMOSTAT DIAL
16	0023040SK	FOOT SERVICE KIT (Incl. Foot, screw, washer, insert & t-nut)
17	0016133	#8-32 SCREW
18	0016144	MAGNETIC STRIP
19	0018030	BLACK DOOR KNOB
20	0016136	#8-32 ACORN NUT
21	0016142	MALE HINGE
22	0016353-BLK	BACK DOOR - BLACK KNOB (CONTROL SIDE)
23	0016141	FEMALE HINGE
24	0016123	THERMOMETER
25	0016138	100W 120V UPPER ELEMENT
26	0016120	118W 120V LOWER ELEMENT
*	I013756	RED "READY TO GO" DECAL 680/690
*	I013757	PIZZA "READY TO GO" DECAL 680/690
*	0016777	FLAT RACK (PANS OR BOXES)
*	0016289	3/4" RAISED RACK
*	0016329	DUMMY PLUG

Model 680-2 Exploded View

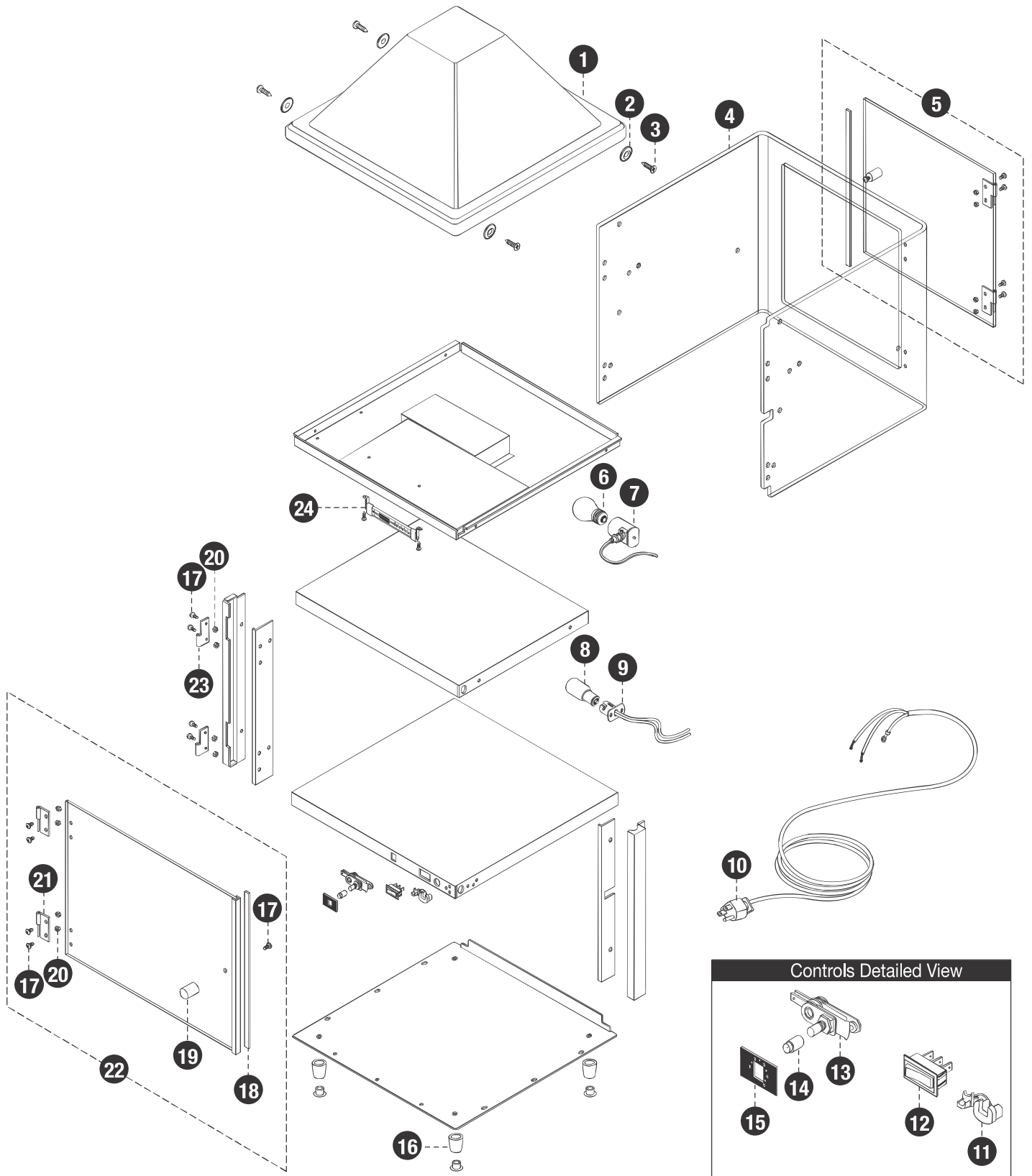

Model 680-2 Wiring Diagram

Current Model (Single Switch)

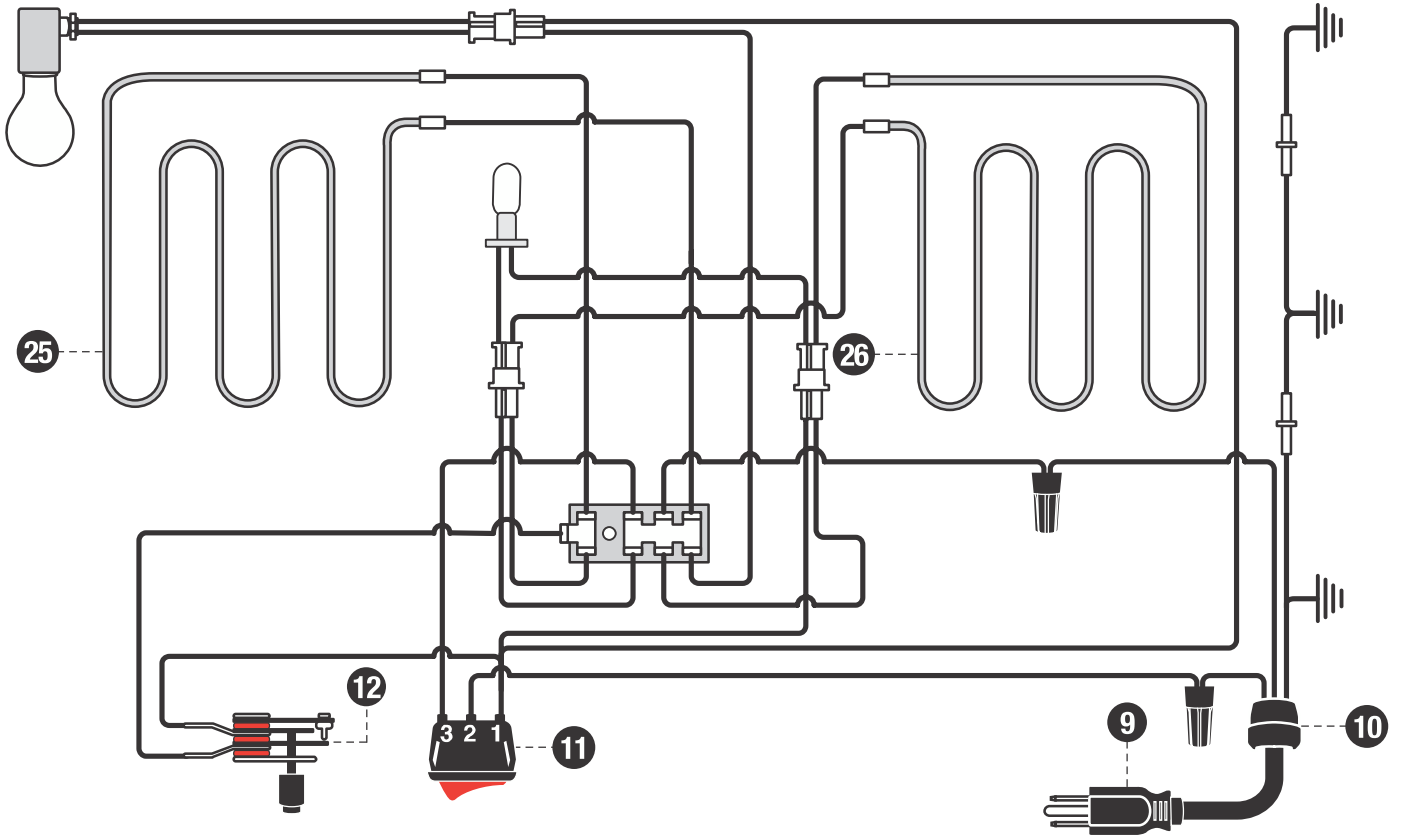

Obsolete Model (Dual Switch)

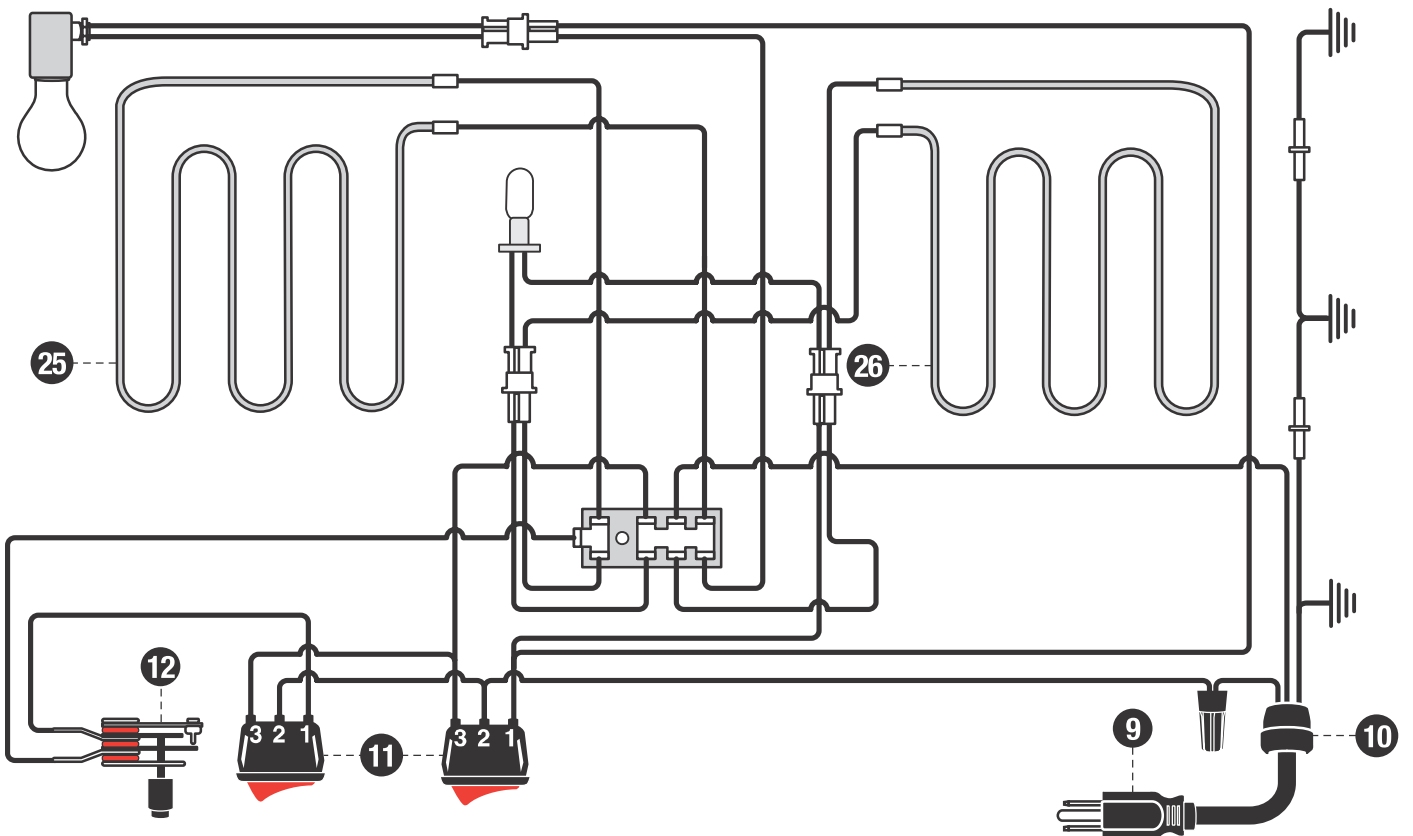

1 YEAR REPLACEMENT/EXCHANGE

Wisco Industries, Inc. warrants its equipment against defects in materials and workmanship subject to the following conditions:

Should any product fail to function in its intended manner under normal use within the limits defined in this warranty, Wisco Industries will determine if the item is to be repaired or replaced by Wisco Industries. Failure to follow authorizing instructions may void any claim and/or warranty.

* Contact Wisco Industries for repair/replacement by calling (608) 835-3106 or toll free (800) 999-4726.

You can also email us at: contact@wiscoind.com

* An authorizing RMA# must be obtained through Wisco Industries BEFORE any warranty issues can be resolved. Failure to do so in advance may void the warranty/claim resulting in Wisco Industries not being responsible for any incurred expenses and/or charges.

* At time of call Wisco Industries will assist you in:

- getting your unit replaced/exchanged
- and/or obtaining repair parts
- and/or authorizing a service agent

This warranty covers products shipped into the 48 contiguous United States, Hawaii, metropolitan areas of Alaska. Warranty for international or areas not listed above will consist of replacement of parts only. There will be no labor coverage and parts must be shipped to an address within the 48 contiguous United States, Hawaii, metropolitan areas of Alaska and Canada only.

Time Period

One year from date of shipment from our manufacturing facility. Parts replaced under this warranty are warranted for the un-expired portion of the original product warranty only.

Exclusions

The following conditions are not covered by warranty:

- Equipment failure relating to improper installation and improper utility connection or supply.
- Equipment that has not been properly maintained or damage from improper cleaning and/or water damage to controls.
- Equipment that has not been used for its intended purpose or has been subject to misuse or misapplication, neglect, abuse, accident, alteration, negligence, damage during subsequent transit, delivery or installation, fire, flood, riot or act of god.
- Equipment that has the model number or serial number removed or altered.

WISCO INDUSTRIES, INC. DISCLAIMS AND EXCLUDES ANY AND ALL OTHER EXPRESS OR IMPLIED WARRANTIES, INCLUDING WITHOUT LIMITATION, ANY AND ALL WARRANTIES OF MERCHANTABILITY OR FITNESS FOR A PARTICULAR PURPOSE.

Buyer agrees that its SOLE AND EXCLUSIVE REMEDY against Wisco and Wisco's SOLE AND EXCLUSIVE LIABILITY arising out of any defect or nonconformity in the product shall be replacement/exchange of such nonconforming countertop food service equipment at Wisco's expense. No countertop food service equipment shall be returned without Wisco's consent. IT IS AGREED THAT WISCO'S MAXIMUM LIABILITY SHALL NOT IN ANY CASE EXCEED THE SALE PRICE FOR THE COUNTERTOP EQUIPMENT CLAIMED TO BE DEFECTIVE OR NONCONFORMING.

Without limiting the generality of the foregoing, SUCH WARRANTIES DO NOT COVER: Glass, plastic enclosures/panels, door assemblies, light bulbs & wire pizza oven heating elements.

SHIPPING DAMAGE

If the outside packaging of your order is visibly dented, crushed, torn or otherwise significantly damaged, or if you move the carton and you hear broken glass, please reject the shipment while driver is still with you if possible. Please call us at (800)999-4726 or email contact@wiscoind.com to notify us of the issue. We will confirm the damage with the carrier and re-ship your order immediately.

RETURN POLICY

You may return any unused, undamaged items within 30 days of receipt. We will issue a refund in the form of your original payment, less a 20% re-stock fee. All returns must be received in resalable condition. Wisco Industries will not accept a return with shipping damage. Wisco Industries will not reimburse any shipping and handling fees.

If you would like to return an item please call us at 608-835-3106 or toll free at 1-800-999-4726 and ask for our Food Service Equipment Division or you may send an email to us at: contact@wiscoind.com You will be given a return # and return instructions. We can not accept returns without a return #. Please be sure to include a copy of the packing list with the return.