

# PIZZA OVEN



## MODEL 412-3PC, RISING DOUGH PIZZA OVEN

This oven was designed expressly for baking rising dough pizzas. This counter top oven has dual position elements which are designed to cook quickly and consistently with no preheating required. Prepare anything you would normally cook in your toaster oven including garlic and cheese breads, egg rolls, bagels, and other food items of a non-greasy nature.

The outer housing and grill front are made from brushed stainless steel. The inner housing and other parts of the oven are made from galvanized and/or aluminized steel for corrosion protection.

### FEATURES:

- Opening: 3" x 13"
- Removable clean out tray
- Preset Thermostat (approx. 450 deg.)
- Mechanical 15 minute timer
- Long life calrod heating elements.
- Flip up handle design for easier storage
- \*\* Bakes (1) 12" Rising dough crust pizza in approx. 12 min. Some "super-rise" doughs require additional time.

### ELECTRICAL DATA:

- 120 volts, 12 amps, 1350 watts
- Best when operated on an individual branch circuit
- 6' power cord length

### DIMENSIONS:

- 7-3/4"H x 18"W x 15"D
- Inside dimension: 13" x 13"

### SHIPPING WEIGHT:

Approx. 20 lbs.



An ISO 9001 Company

FP140044-M  
04/13

## WISCO INDUSTRIES®

P.O. BOX #10  
OREGON, WI 53575  
PHONE: 608-835-3106  
FAX: 608-835-8273  
www.thepizzaoven.biz

### LIMITED WARRANTY:

Wisco Industries, Inc. expressly warrants the product will be free from defects in workmanship and materials for a period of 90 days (1 year mechanical) from the date of shipment. WISCO DISCLAIMS AND EXCLUDES ANY AND ALL OTHER EXPRESS OR IMPLIED WARRANTIES, INCLUDING WITHOUT LIMITATION, ANY AND ALL WARRANTIES OF MERCHANTABILITY OR FITNESS FOR A PARTICULAR PURPOSE.

Buyer agrees that its SOLE AND EXCLUSIVE REMEDY against Wisco and Wisco's SOLE AND EXCLUSIVE LIABILITY arising out of any defect or nonconformity in the product shall be Wisco's option either to repair or replace such nonconforming countertop food service equipment at Wisco's expense. No countertop food service equipment shall be returned without Wisco's consent. IT IS AGREED THAT WISCO'S MAXIMUM LIABILITY SHALL NOT IN ANY CASE EXCEED THE SALE PRICE FOR THE COUNTERTOP EQUIPMENT CLAIMED TO BE DEFECTIVE OR NONCONFORMING.

# INSTRUCTION MANUAL FOR MODEL 412-3PC

## **WARNINGS**

- IMPROPER ASSEMBLY OF THE "FLIP UP" HANDLE TO THE GRILL COULD CAUSE THE GRILL TO ROTATE WHEN THE PIZZA IS REMOVED FROM THE OVEN. THIS COULD RESULT IN INJURY TO THE INDIVIDUAL SHOULD THEY ATTEMPT TO KEEP THE PIZZA FROM FALLING ON THE FLOOR. (See special assembly instructions attached to or as part of this instruction manual.)
- THE OVEN SHOULD NEVER BE OPERATED ON OR NEAR COMBUSTIBLE MATERIALS. CAUTION SHOULD BE TAKEN BECAUSE OF THE HOT SURFACES ATTAINED DURING USE. WE RECOMMEND 6" SPACING FROM WALLS.
- UNPLUG OVEN WHEN NOT IN USE
- WHEN REMOVING GRILL FROM OVEN, USE CAUTION, TO AVOID FOOD FALLING INTO THE OVEN, ON THE OPERATOR, ETC.

## **ASSEMBLING COMPONENT PARTS**

Included with your oven is a plastic bag containing the grill handle, clean-out tray knob and appropriate screws and nuts. See the instruction sheet for assembling the flip up handle and clean-out tray.

## **BAKING INSTRUCTIONS**

Pizza should be kept frozen for best results. Capacity is (1) 12" rising-dough crust pizza at a time. Oven can be turned on just prior to placing the pizza into the oven. After placing the pizza in the oven, set the timer dial to the desired bake time.

\*The timer dial must always be turned past the 2 minute mark to activate the switch. Baking time varies depending upon the thickness of pizza, toppings, etc. The average time is between 12-15 minutes. It is recommended that the drawer be opened halfway through baking time to check progress; it may be necessary to rotate pizza at this time.

## **CLEANING INSTRUCTIONS**

These ovens are designed with a clean-out tray which should be pulled out and cleaned often with warm soapy water and then dried thoroughly. Most of the spillage will fall directly on this tray, and if this is cleaned off and not allowed to build up, the internal parts of the oven will stay relatively clean. Additionally, proper cleaning prevents emergence of smoke caused by a build up of carbon. The outside of the oven may be cleaned with a soft rag and stainless steel cleaner. As with all metals, there could be some sharp edges, and caution should be used when cleaning.

**DO NOT USE ANY OVEN/RANGE CLEANERS ON THIS UNIT.**

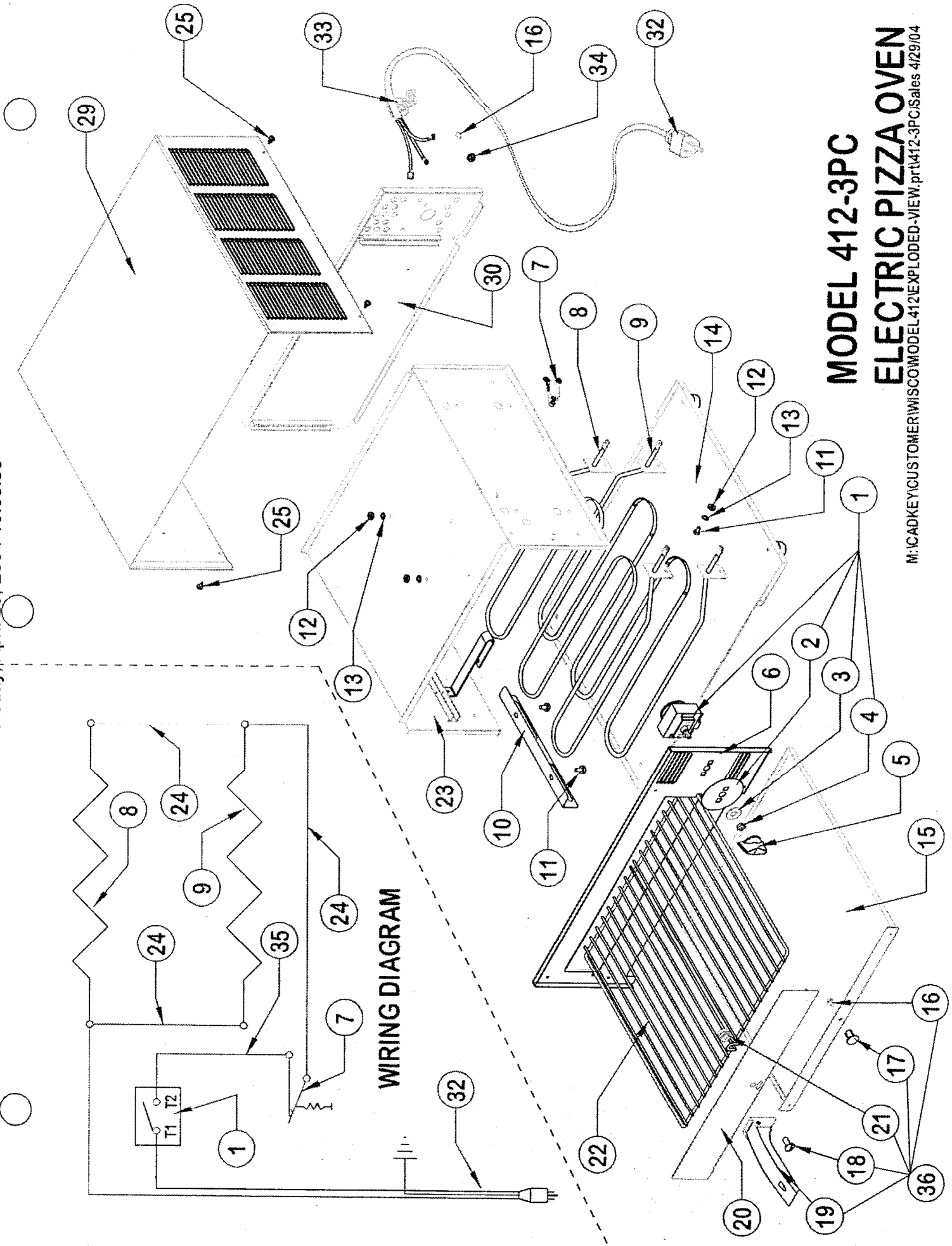

WIRING DIAGRAM

# MODEL 412-3PC ELECTRIC PIZZA OVEN

M:ICADKEYCUSTOMERWISCOMODEL412EXPLODED-VIEW,prt412-3PC\Sales 4129104

**MODEL 412-3PC**

<u>ITEM #</u>	<u>PART #</u>	<u>DESCRIPTION</u>
1	0017314SK	TIMER KIT w/decal,wires & instructions
*	0017314	20 AMP TIMER ONLY
2	I013395	TIMER DIAL
3	00497	#WS53 WASHER .401 X .805 X .051
4	00175	NUT
5	00106	TIMER KNOB
6	RA19426N	FRONT PANEL
7	00449	REGULATING THERMOSTAT
8	00163N	HEATING ELEMENT 700 W. 120V
9	00499	HEATING ELEMENT 550W @ 100V
10	00410	UPPER ELEMENT SUPPORT
11	00151	#10-24 x 1/4 SCREW
12	00142	10-24 HEX NUT
13	009124	#10 LOCK WASHER
14	RA423N	BOTTOM PAN ASSY W/FEET
*	00475	RUBBER INSERT
15	RA441N	CLEAN-OUT TRAY
16	00144	8-32 X 1/4" PHILLIPS HEAD STAINLESS
17	00122	CLEANOUT TRAY KNOB
18	SW121	1/4 -20 THUMB SCREW
19	Handle	See item #36
20	0019113N	GRILLE FRONT PANEL
21	00478	1/4 -20 THUMB NUT
22	WA496	GRILLE
23	RA19412H	INNER HOUSING
24	00130	8-1/2" INTERNAL WIRE
25	00150	#8 X 3/8 SHEET METAL SCREW
29	00444N	OUTER HOUSING
30	RA424N	REAR PANEL SUB ASSEMBLY
*	SA484N	REAR PANEL with CORD
32	00132	POWER CORD
33	00131	STRAIN RELIEF
34	0016108	8-32 SPINLOCK NUT NICKEL
35	0016518	14GA STRAND WHITE WIRE
36	0023019	BAG OF PARTS (Incl. Handle, nut, screw & clean out tray knob & screw)

# Pizza Oven Handle Assembly Instructions

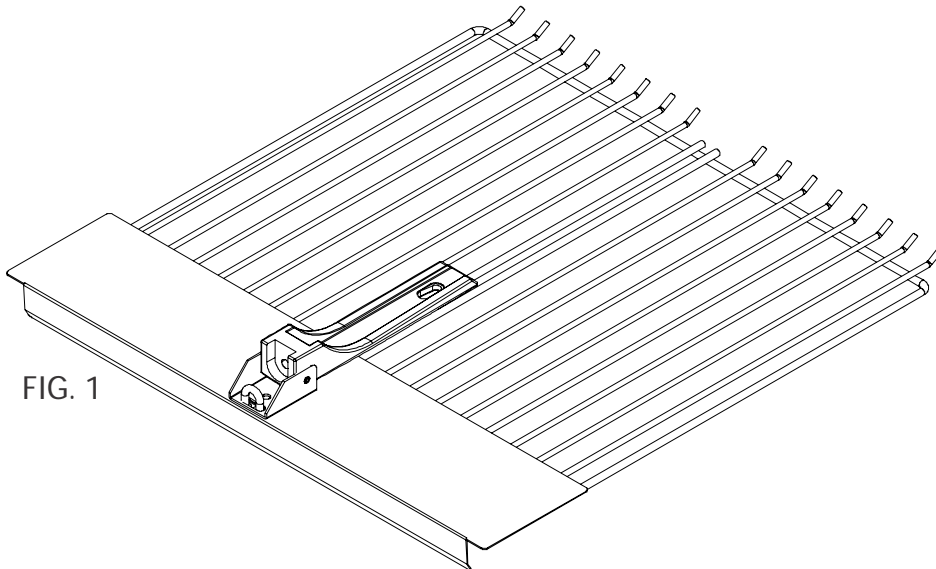
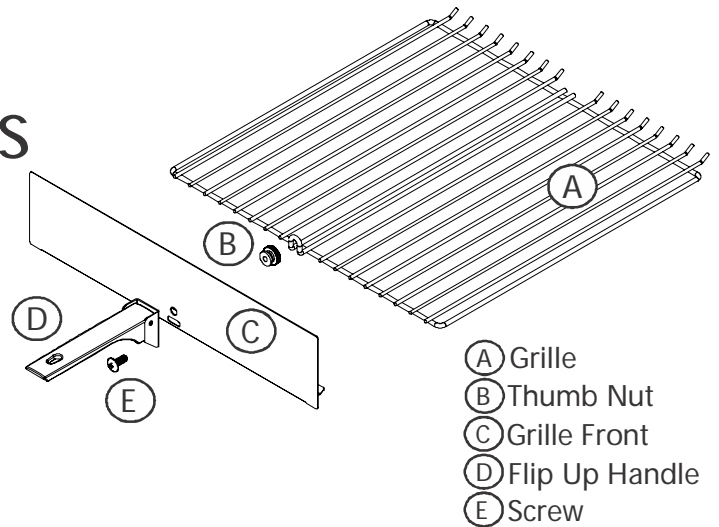

FIG. 1

## STEP 1

With the grille laying flat, slide the grille front over the grille loop allowing it to lay flat. Place the handle bracket over the loop. FIG. 1.

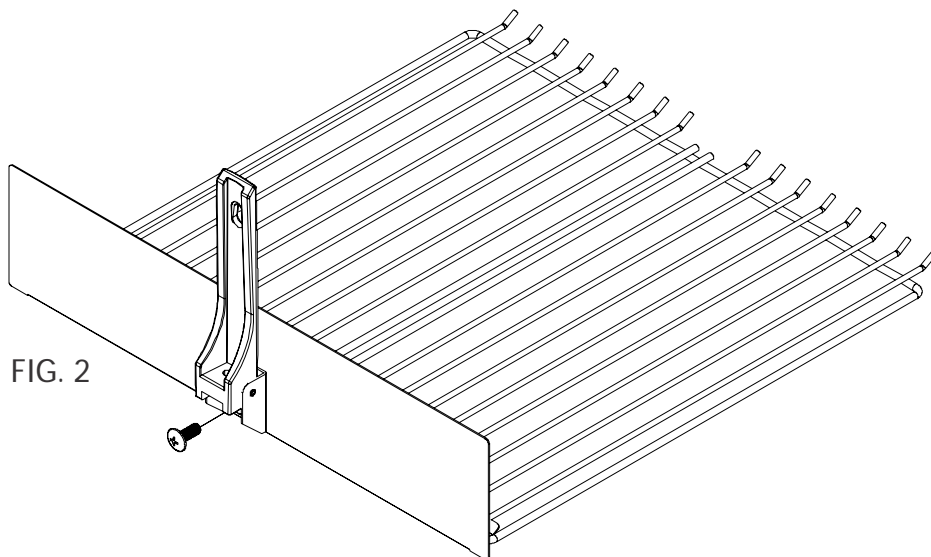

FIG. 2

## STEP 2

Rotate the grille front and handle into the upright position. FIG. 2

## STEP 3

Insert the screw through the grille loop, the handle bracket and the grille front. FIG. 3

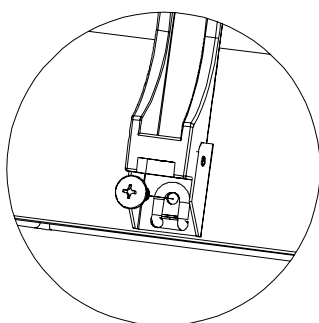

FIG. 3

## STEP 4

Thread the thumb nut onto the screw and tighten. Rotate the handle down and slide the grille into the oven for use. FIG. 4

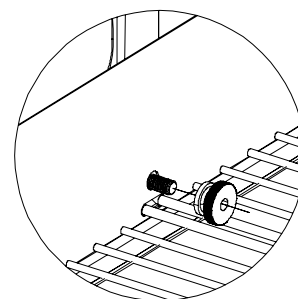

FIG. 4



An ISO 9001 Company

**WISCO INDUSTRIES, INC.**  
P.O. BOX 10 OREGON, WI 53575  
TELEPHONE (608)835-3106/(800)999-4726 FAX (608)835/8273

## WARRANTY INFORMATION

### \* 1 YEAR REPLACEMENT/EXCHANGE \*

If you should experience any mechanical difficulties with your Wisco Industries, Inc. manufactured unit during the 1 year warranty time period please do the following:

- \* Contact Wisco Industries, Inc. for repair/replacement by calling (608)835-3106 or Toll Free (800)999-4726.
- \* Please have your **MODEL #** and **SERIAL #** available. These numbers can be found on a black decal located on the lower side of the unit. There is also a date of manufacturing that can be found on the bottom of the unit.
- \* At that time, we can assist you in:
  - getting your unit replaced/exchanged
  - and/or obtaining repair parts
  - and/or authorizing a service agent
- \*\* Please note that you **MUST** contact Wisco Industries, Inc. and obtain a RMA# **BEFORE** any warranty issues can be resolved. ***Failure to do so may void the warranty/claim resulting in Wisco Industries, Inc. not being responsible for any incurred expenses and/or charges.***

#### LIMITED WARRANTY:

Wisco Industries, Inc. expressly warrants the product will be free from defects in workmanship and materials for a period of 1 year from the date of shipment. WISCO DISCLAIMS AND EXCLUDES ANY AND ALL OTHER EXPRESS OR IMPLIED WARRANTIES, INCLUDING WITHOUT LIMITATION, ANY AND ALL WARRANTIES OF MERCHANTABILITY OR FITNESS FOR A PARTICULAR PURPOSE.

Buyer agrees that its **SOLE AND EXCLUSIVE REMEDY** against Wisco and Wisco's **SOLE AND EXCLUSIVE LIABILITY** arising out of any defect or nonconformity in the product shall be replacement/exchange of such nonconforming countertop food service equipment at Wisco's expense. No countertop food service equipment shall be returned without Wisco's consent. **IT IS AGREED THAT WISCO'S MAXIMUM LIABILITY SHALL NOT IN ANY CASE EXCEED THE SALE PRICE FOR THE COUNTERTOP EQUIPMENT CLAIMED TO BE DEFECTIVE OR NONCONFORMING.**