



Series 4 Oil-Fired Steam Boilers

Boiler Manual

- Installation
- Maintenance
- Startup
- Parts



⚠ WARNING

This manual must only be used by a qualified heating installer/service technician. BEFORE installing, read all instructions in this manual and all other information shipped with the boiler. Perform steps in the order given. Failure to comply could result in severe personal injury, death or substantial property damage.



▲WARNING HOMEOWNER and SERVICE TECHNICIAN — read and follow completely.

Using this manual

Homeowner —

Read and follow all information on pages 1 through 7 ONLY.

Service technician —

Read and follow ALL information in the entire manual.

▲WARNING Failure to follow all instructions in proper order can cause severe personal injury, death or substantial property damage.

When calling or writing about the boiler

Please have boiler model number and series from boiler rating label and Consumer Protection (CP) number(s) from boiler jacket, burner and controls. On page 35 of this manual is space to list CP number(s).

- Packaged boilers:** Available only in sizes 3 through 6, are factory assembled, completed with block, collector hood, jacket, controls and trim (damper included, shipped loose inside boiler shipping carton). Burner is ordered and shipped separately
- Semi-packaged boilers:** Available only in sizes 3 through 6, are shipped with block assembled with collector hood and jacket installed. Control, trim, damper and burner are ordered and shipped separately for field assembly.
- Knocked-down boilers:** Available in sizes 3 through 9, are shipped with block assembled only. All other components are ordered and shipped separately for field assembly.

Hazard definitions

The following defined terms are used throughout this manual to bring attention to the presence of hazards of various risk levels or to important information concerning the life of the product.

▲ DANGER Indicates presence of hazards that will cause severe personal injury, death or substantial property damage.

▲WARNING Indicates presence of hazards that can cause severe personal injury, death or substantial property damage.

▲CAUTION Indicates presence of hazards that will or can cause minor personal injury or property damage.

NOTICE Indicates special instructions on installation, operation or maintenance that are important but not related to personal injury or property damage.



⚠ WARNING HOMEOWNER and SERVICE TECHNICIAN — read and follow completely.

Contents

Using this manual2	To connect SGO boilers to indirect-fired water heaters	20
When calling or writing about the boiler2	Optional reservoir piping	23
Packaged, Semi-packaged and Knocked-down boilers	2	Connect tankless heater piping	24
Hazard definitions2	To pipe tankless heater.	24
Contents3	Connect wiring — general information	26
Read this first !4	General wiring requirements	26
Routine maintenance schedule.5	Thermostat wiring	26
Beginning each heating season5	Junction box (furnished)	26
Daily during heating season5	Burner wiring	26
Weekly during heating season5	High temperature limit	26
Periodically during heating season5	Blocked vent shutoff switch	27
End of heating season5	Connect wiring (Float-type LWCO)	28
Boiler shutdown5	Blocked vent shutoff switch (BVSS), when required	29
Please read this before proceeding6	Connect wiring (Probe-type LWCO)	30
Start-Up6	Blocked vent shutoff switch (BVSS), when required	31
Check Daily6	OVD Vent damper wiring	32
Check Monthly6	Connect oil piping	32
Check Periodically6	General oil piping requirements	32
Troubleshooting7	Oil piping connection at burner	32
Before installing boiler8	Start up.	33
Installations must comply with8	Steam water treatment	33
Before selecting boiler location8	Fill the system	34
Provide clearances around boiler (see Figure 2)8	Tips for steam systems.	34
Provide air for combustion and ventilation9	Skim steam boiler.	34
Lay a foundation, if needed9	To place in operation	34
Air contamination.	10	Check out procedure	35
Operation.	11	Check off “Steps” as completed	35
SGO with float-type low water cutoff	11	Installation and service certificate	35
SGO with probe-type low water cutoff.	12	Annual service check list	36
Install boiler - Packaged boilers only	13	Service and maintenance.	37
Place boiler	13	General description of control operation	37
Perform hydrostatic pressure test	13	Burner adjustments	37
Install boiler - Semi-packaged & Knocked-down boilers	14	Controls requiring annual service	37
Place boiler	14	Cleaning boiler flue ways.	38
Tankless heater, if used.	14	Inspect	38
Perform hydrostatic pressure test	16	Reported problems	38
Install jacket (Knocked-down boilers only)	16	Boiler area	38
Install boiler controls	16	Piping	38
Install burner and chimney — all boilers	18	Service	39
Install burner (also refer to instructions packed with burner)	18	Check/test	39
General chimney requirements.	18	Check monthly.	39
Connect breeching	18	Boiler and system piping	40
Connect breeching	18	Review with owner.	40
Connect steam piping.	20	Boiler relief valve.	40
General piping information	20	Replacement parts	41
Install piping	20	Dimensions	46
		Ratings	47
		Handling ceramic fiber and fiberglass materials	48

**▲WARNING** HOMEOWNER and SERVICE TECHNICIAN — read and follow completely.

Read this first!

Homeowner —

- For homeowner or person responsible for simple start-up and routine maintenance of the system.

Instructions on 1 through page 7 must be followed to assure proper operation of your boiler. See page 7 for lists common problems and possible corrections. In addition, it is your responsibility to:

- Have boiler and burner installed by a qualified installer.
- Have boiler and burner serviced annually by a qualified service technician.
- Review and understand start-up and routine maintenance procedures with qualified service technician.
- Perform routine maintenance as described on page 5 and

Service technician —

- For a qualified service technician who has the necessary equipment to check the boiler and system performance, and is responsible for start-up and service of boiler and system.
- All instructions in this manual must be followed to assure proper operation of this boiler.
- Annually service boiler and burner to assure proper operation. See page 36 for service record.
- Review and explain start-up and routine maintenance procedures with homeowner.

▲WARNING Follow instructions below to prevent severe personal injury, death or substantial property damage:

- To avoid electric shock, disconnect electrical supply to burner service switch and additional external switches before performing service.
- To avoid severe burns, allow boiler to cool before performing service.
- Do not block flow of combustion or ventilation air to boiler.
- Boiler must be connected to a flue with sufficient draft at all times to assure proper operation.

Do not use this boiler if any part has been under water. Electrical and mechanical failures may cause electric shock and fire risks. Immediately call a qualified service technician to inspect chimney or vent, boiler and burner. Have the boiler flue ways cleaned and have the following replaced:

- all electrical and mechanical controls
- electrical wiring
- oil burner and controls
- insulation and chamber lining

Tips for water systems —

- Check boiler and system piping for leaks. Continual makeup water will reduce boiler life. Minerals can build up in sections, reducing heat transfer and causing cast iron to overheat, resulting in section failure.

▲CAUTION Failure to maintain recommended pH and repair leaks can cause section iron corrosion, leading to section failure and leaks. Do not use petroleum-based sealing or stop-leak compounds in boiler systems. Damage to system components can result, causing property damage.

- Boiler water pH 7.0 to 8.5 is recommended. For pH conditions outside 7.0 to 8.5 range or unusually hard water areas (above 7 grains hardness), consult local water treatment company.
- When using antifreeze:
 - Use antifreeze especially made for hydronic systems. Inhibited propylene glycol is recommended.

▲WARNING Do not use automotive, ethylene glycol, undiluted or petroleum-based antifreeze. Severe personal injury, death or substantial property damage can result.

- 50% solution provides protection to about -30°F .
- Local codes may require back-flow preventer or actual disconnect from city water supply.
- Determine quantity according to system water content. Boiler water content is listed on back cover of Boiler Manual.
- Percent of solution will affect sizing of heat distribution units, circulator and expansion tank.
- Follow antifreeze manufacturer's instructions.
- Do not add cold water to hot boiler. Thermal shock can cause sections to crack.

Saltwater Damage — The exposure of boiler components to saltwater can have both immediate and long-term effects. While the immediate effects of saltwater damage are similar to those of freshwater (shorting out of electrical components, washing out of critical lubricants, etc.), the salt and other contaminants left behind can lead to longer term issues after the water is gone due to the conductive and corrosive nature of the salt residue. Therefore, Weil-McLain equipment contaminated with saltwater or polluted water will no longer be covered under warranty and should be replaced.

Electrical Damage — If any **electrical component** or **wiring** came into contact with water, or was suspected to have come into contact with water, replace the boiler with a new Weil-McLain boiler.

▲CAUTION Frozen Water Damage Hazard

Residences or buildings that are unattended in severely cold weather, boiler system components failures, power outages, or other electrical system failures could result in frozen plumbing and water damage in a matter of hours. For your protection, take preventative actions such as having a security system installed that operates during power outages, senses low temperature, and initiates an effective action. Consult with your boiler contractor or a home security agency.



⚠ WARNING HOMEOWNER and SERVICE TECHNICIAN — read and follow completely.

Routine maintenance schedule

<p>Beginning each heating season</p>	<ul style="list-style-type: none"> <input type="checkbox"/> Call a qualified service technician to perform annual service.
<p>Daily during heating season</p>	<ul style="list-style-type: none"> <input type="checkbox"/> Check that boiler area is free from combustible materials, gasoline and other flammable vapors and liquids.
<p>Weekly during heating season</p>	<ul style="list-style-type: none"> <input type="checkbox"/> Check for and remove any obstructions to flow of combustion or ventilation air to boiler. <input type="checkbox"/> Check that breeching is attached between boiler and chimney. If breeching is loose or damaged, immediately turn off switch on boiler and call service technician to repair. <input type="checkbox"/> Check for oil leaks in oil piping and around burner. If found, immediately call qualified service technician to correct situation. <input type="checkbox"/> Check for water leaks in boiler and piping; also check for leaks around tankless heater plate, if installed. If found, immediately call service technician to repair. <input type="checkbox"/> Check float-type low water cutoff, when used: Refer to control manufacturer's instructions. <p>⚠ DANGER Scald potential. Do not blow down low water cutoff unless blow down piping has been installed according to Boiler Manual. If piping is not in place, call qualified service technician to install.</p>
<p>Periodically during heating season</p>	<ul style="list-style-type: none"> <input type="checkbox"/> Test probe-type low water cutoff, when used: refer to control manufacturer's instructions.
<p>End of heating season</p>	<ul style="list-style-type: none"> <input type="checkbox"/> If tankless heater is installed, boiler will continue to operate. Check for the following: <ul style="list-style-type: none"> • All daily and weekly instructions listed on this page must be followed. • Burner motor may have to be oiled. Some motors are permanently lubricated and do not need additional oil. Check for oiling instructions on burner or motor.
<p>Boiler shutdown</p>	<ul style="list-style-type: none"> <input type="checkbox"/> Do not drain boiler unless exposure to freezing temperatures will occur. <input type="checkbox"/> Do not use antifreeze in steam systems. <input type="checkbox"/> Always keep manual fuel supply shut off if burner is shut down for an extended period of time. <ul style="list-style-type: none"> • Turn off switch at boiler and any external switch to boiler. • Close fuel valves. • Turn off water feed valve. • Cover burner to protect from dust and dampness.



WARNING HOMEOWNER and SERVICE TECHNICIAN — read and follow completely.

Please read this before proceeding

Start-up

- If burner does not fire, check for:
 - Boiler switch turned off?
 - Fuses blown or breaker tripped?
 - Thermostat set below room temperature?
 - Fuel valves turned off?
 - Water not visible in gauge glass?
 - Not enough oil in tank to supply burner?
- Correct problems found in step #1. If burner does not fire, press the reset button on burner primary control only once. Repeated presses will deposit oil in chamber, creating a fire hazard.

⚠ DANGER Burner must never be fired when oil is in combustion chamber. Immediately call a qualified service technician.

- If burner still does not fire, call a qualified service technician.

Pressure gauge

- Pressure gauge must not show more than 15 psig (normally 5 psig). Contact a qualified service technician if high pressure occurs.

Air openings

Verify that combustion and ventilation air openings to the boiler room and/or building are open and unobstructed.

☐ Check monthly

- Venting system, see page 39.
- Boiler and system piping, see page 39.
- Boiler relief valve, see page 40.

Figure 1 Boiler and components

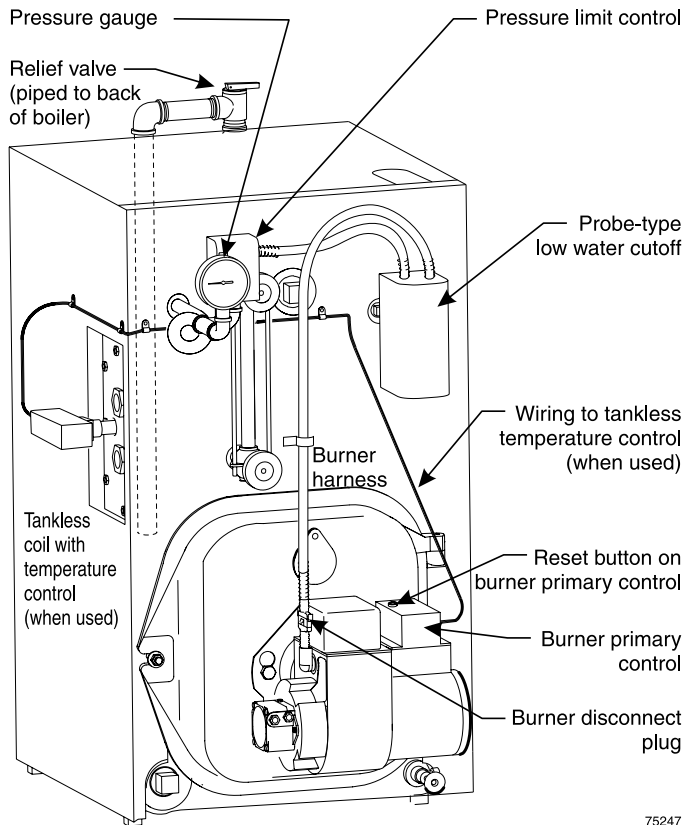

75247

☐ Check daily

Boiler area

- Check that boiler area is free from combustible materials, gasoline and other flammable vapors and liquids. Ensure that no air-contaminating materials (see page 10) are present in the area.

☐ Periodically

Oil motors equipped with oil cups

Burner motors may require oiling. Such motors are fitted with oiling cups. Use a few drops only of SAE 20 detergent oil. Do not use household oils. Excessive oiling can damage motors. Do not attempt to “fill up” the oiling cup.

Test low water cutoff(s)

Probe-type low water cutoff

- Turn off power to boiler and wait 5 minutes.
- Drain water to bottom of gauge glass.
- Turn on power.
- Set thermostat to call for heat. Red neon lamp on low water cutoff should light.
- Wait 5 minutes. Boiler should not fire.
- Refill boiler to correct water line. Red lamp should go off.
- Wait 5 minutes. Boiler should fire.
- Return thermostat to normal setting.

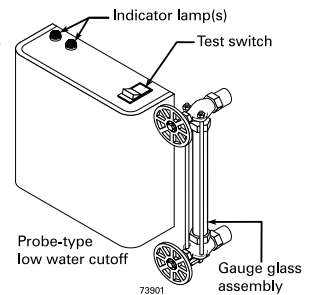

Float-type low water cutoff (by others, if used)

Blow down control and test per control manufacturer's instructions.

⚠ DANGER Scald potential. Do not blow down low water cutoff unless blow down piping has been installed according to control manufacturer's instructions. If piping is not installed, call a qualified service technician.



⚠WARNING HOMEOWNER and SERVICE TECHNICIAN — read and follow completely.

Troubleshooting

⚠WARNING Homeowners — The problems and corrections below represent common situations that can occur. There may be others not listed below. It is important always to contact a qualified service technician if you have any questions about the operation of your boiler or system.

Common problems	Common causes	Possible corrections
Rapid cycling - burner turns on and off frequently.	Thermostat installed where drafts or heat affect reading.	Locate thermostat on inner wall away from heat sources or cool drafts.
	Heat anticipator setting in thermostat set incorrectly.	Consult thermostat manufacturer instructions or set heat anticipator to match current draw of circuit it is attached to. (Burner primary control, T-stat switching relay coil, etc.).
	Main and/or radiator vents not working properly (one-pipe steam) or traps not working properly (two-pipe steam).	Contact service technician to check, repair or replace air vents and traps.
	Incorrect pressure limit setting.	Set pressure cut-in and differential according to system needs. Typical one and two pipe systems need less than 2 psig. Typical cut-in setting is ½ -1 psi and differential of 1 psi. Try increasing differential in ½ psi increments for longer cycle times.
Frequent release of water or steam through relief valve.	Inoperative limit control.	If pressure in boiler is approaching 15 PSI, check pressure control setting, operation & wiring. Replace if defective.
	Incorrect or defective relief valve.	Check for proper relief valve (15 psi). If opening at less than 15 psig, replace.
Need to frequently add makeup water.	Leaks in boiler or piping.	Have qualified service technician repair leaks at once to avoid constant use of makeup water.
Black or rust colored water condition.	Black oxide or oxidation (rust) due to leaks in boiler, air vents or piping. Improper pH.	Have qualified service technician repair leaks at once. Keep pH of water between 7.0 to 8.5.
Popping or percolating noise heard in boiler.	Mineral deposits in sections due to constant use of makeup water. Or incorrect pH.	Have qualified service technician de-lime boiler and repair leaks at once to avoid constant use of makeup water and check ph (7.0 to 8.5).
Metal flakes found in vent outlet or vent — flue way corrosion.	Contaminated combustion air supply.	Remove any contaminating products. See page 10 of this manual. Provide outside air for combustion.
	Condensation of combustion gases in flue ways.	Have a qualified service technician check burner nozzle and oil pump pressure for proper firing rate and check/adjust combustion settings with analyzer.
Some radiators or baseboard units do not heat.	Main or radiator air vents (one pipe system) or traps (two pipe system) not operating correctly.	Have qualified service technician inspect, repair or replace faulty air vents or traps.
	Incorrect pressure limit setting.	Set pressure cut in and differential according to system needs. Typical one and two pipe systems need less than 2 psig. Typical cut in setting is ½ -1 psi and differential of 1 psi.
	Clogged piping, valves or radiator. Or inoperable/ closed radiator valve.	Have qualified service technician clean or replace clogged components.
Water disappearing from gauge glass and back into system through return piping.	Incorrect Hartford loop piping.	Have qualified service technician pipe boiler exactly as shown in boiler manual.
	Check-valve inoperative.	Have qualified service technician clean or replace check-valve.
	Vacuum-breaker inoperative.	Have qualified service technician clean or replace vacuum breaker.
Violent waterline fluctuations surging OR Water passing into steam mains priming.	Dirt, oil or other impurities in water.	Have qualified service technician skim boiler.
	Waterline too high.	Have qualified service technician adjust waterline to normal height.
	Incorrect piping.	Have qualified service technician pipe boiler exactly as shown in boiler manual.
	Sudden release of boiler steam pressure by action of zone valves.	Have qualified service technician adjust valve operating time or install slow-opening valves.
Domestic water from tankless heater is hot then suddenly turns cold. Or Domestic water from tankless heater is always lukewarm.	Mineral deposits insulate internal waterways of heater.	Have qualified service technician delime or replace coil.
	Boiler stop-leak compound has been added to boiler water and is insulating outside of coil.	Have qualified service technician remove and clean coil and drain and flush boiler to remove stop-leak.
	Incorrect mixing valve setting for tankless heater.	Have qualified service technician adjust mixing valve setting.
	Domestic flow rate too high.	Have qualified service technician install flow check valve set to rating of tankless heater.
	Incorrect setting on tankless heater control.	Have qualified service technician raise tankless control setting. Adjust differential on tankless control to lower setting.



WARNING HOMEOWNER and SERVICE TECHNICIAN — read and follow completely.

Before installing boiler

DANGER Homeowner — STOP! The procedures and information on this and following pages are intended only for a qualified service technician who has the necessary equipment to inspect and adjust boiler and burner. A homeowner should never attempt these procedures. The service technician must also read pages 1 through 7 before proceeding.

Installations must comply with

United States

- State and local plumbing, heating and electrical codes.
- National codes where applicable.
- Standard for Controls and Safety Devices for Automatically Fired Boilers, ANSI/ASME CSD-1, – latest edition, when required.
- National Electrical Code, ANSI/NFPA 70, – latest edition and any additional national, state or local codes.

Canada

- Canadian Standards Association, CSA B139, Installation Code for Oil-Burning Equipment - latest edition.
- CSA C22.1 Canadian Electrical Code Part One - latest edition.
- Applicable local or provincial codes.

Before selecting boiler location

Check for nearby connections to:

- System water piping.
- Chimney. See page 18. Boiler can be top or back vented.
- Combustion and ventilation air supply. See page 9.
- Oil supply. See page 32 for oil line routing.
- Electrical power.

Check area around boiler. Remove any combustible materials, gasoline and other flammable liquids.

WARNING Failure to keep boiler area clear and free of combustible materials, gasoline and other flammable liquids and vapors can result in severe personal injury, death or substantial property damage.

Provide clearances around boiler (see Figure 2)

NOTICE Jacket cap must be in place on boiler to avoid requiring an 9" minimum clearance from back or top of boiler to combustible material.

MINIMUM clearances from vent pipe to combustible material:

- 6 inches — Type "L" double-wall vent
- 9 inches — Single-wall vent

NOTICE Flue pipe clearances must take precedence over jacket clearances.

Recommended SERVICE clearances:

- 24 inches — Front and top
- 6 inches — Left side, back and right side
- 15 inches — Left side with tankless heater
- 12 inches — Right side for burner door swing radius

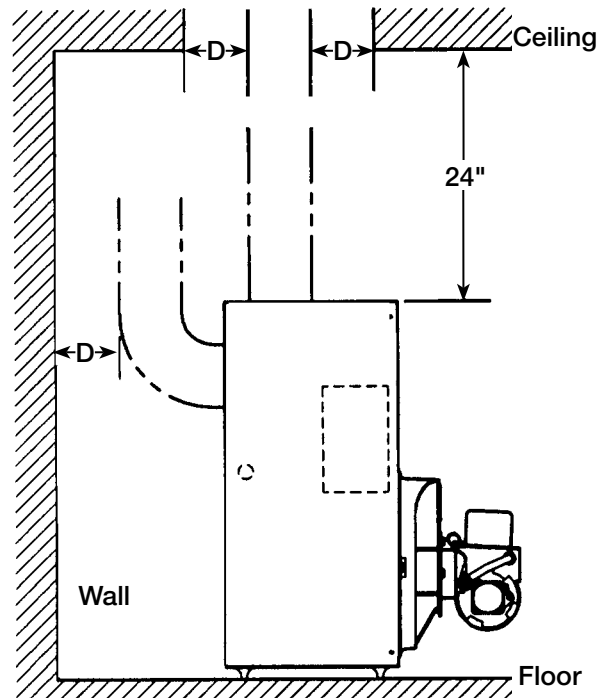
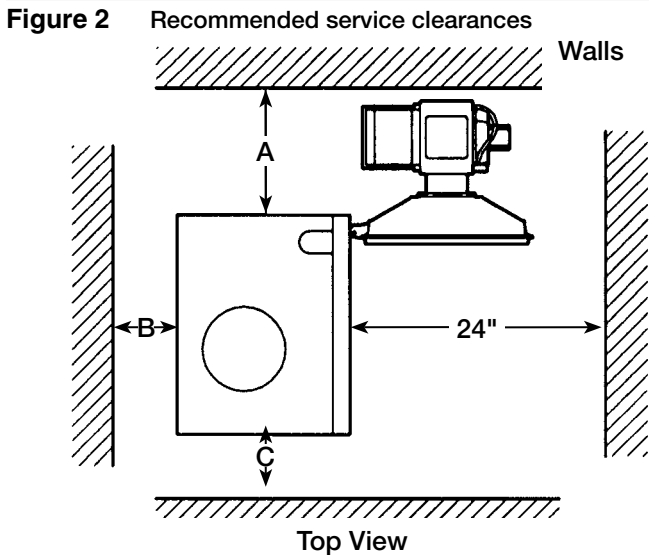

- A** Provide 6" minimum clearance for service, provide 12" minimum clearance for burner door swing.
- B** Provide 6" minimum clearance for service.
- C** Provide 6" minimum clearance for service, provide 15" left side with tankless heater.
- D** Minimum clearance from vent pipe to combustible material: 6" for type "L" double-wall vent, 9" for single-wall vent.



Before installing boiler (continued)

Provide air for combustion and ventilation

▲WARNING Do not install exhaust fan in boiler room.

Adequate combustion and ventilation air:

- Assures proper combustion.
- Reduces risk of severe personal injury or death from possible flue gas leakage and carbon monoxide emissions.

Older buildings with single-pane windows, minimal weather-stripping and no vapor barrier often provide enough natural infiltration and ventilation without dedicated openings.

New construction or remodeled buildings are most often built tighter. Windows and doors are weather-stripped, vapor barriers are used and openings in walls are caulked. As a result, such tight construction is unlikely to allow proper natural air infiltration and ventilation.

Follow state, provincial or local codes when sizing adequate combustion and ventilation air openings. In absence of codes, use the following guidelines when boiler is in a confined room (defined by NFPA 31 as less than 7200 cubic feet per 1 GPH input of all appliances in area. A room 8 ft. high x 33.5 ft. x 33.5 ft. is 7200 cu. ft.):

- Provide two permanent openings — one within 12 inches of ceiling, one within 12 inches of floor. Minimum height or length dimension of each rectangular opening should be at least 3 inches.
- When inside air is used — each opening must freely connect with areas having adequate infiltration from outside. Each opening should be at least 140 sq. in. per 1 GPH input (1 sq. in. per 1000 Btu input) of all fuel-burning appliances plus requirements for any equipment that can pull air from room (including clothes dryer and fireplace).

When outside air is used — connect each opening directly or by ducts to the outdoors or to crawl or attic space that freely connects with outdoors. Size per below:

- Through outside wall or vertical ducts — at least 35 sq. in. per 1 GPH input (1 sq. in. per 4000 Btu input) of all fuel-burning appliances plus requirements for any equipment that can pull air from room (including clothes dryer and fireplace).
- Through horizontal ducts — at least 70 sq. in. per 1 GPH boiler input (1 sq. in. per 2000 Btu input) of all fuel-burning appliances plus requirements for any equipment that can pull air from room (including clothes dryer and fireplace).
- Where ducts are used, they should have same cross-sectional area as free area of openings to which they connect. Compensate for louver, grille or screen blockage when calculating free air openings. Refer to their manufacturer’s instructions for details. If unknown, use:
 - Wood louvers, which provide 20-25% free air.
 - Metal louvers or grilles, which provide 60-75% free air.

Lock louvers in open position or interlock with equipment to prove open before boiler operation.

Lay a foundation, if needed

Boiler may be installed on non-carpeted combustible flooring.

For residential garage installation, install boiler so burner is at least 18 inches above floor to avoid contact with gasoline fumes.

A level concrete or masonry foundation is required when:

- Floor could possibly become flooded.
- Non-level conditions exist.

Solid concrete blocks can be used to create a pad.

Table 1 Boiler foundation sizes

Boiler model	Length inches	Width inches	Minimum height inches
SGO-3	17	22	2
SGO-4	20	22	2
SGO-5	23	22	2
SGO-6	26	22	2
SGO-7	29	22	2
SGO-8	32	22	2
SGO-9	35	22	2



▲WARNING HOMEOWNER and SERVICE TECHNICIAN — read and follow completely.

Before installing boiler continued

Air contamination

Please review the following information on potential combustion air contamination problems.

See Table 2 for products and areas which may cause contaminated combustion air.

▲WARNING To prevent potential of severe personal injury or death, check for products or areas listed below before installing boiler. If any of these contaminants are found:

- remove contaminants permanently.
- OR —
- isolate boiler and provide outside combustion air. See national, provincial or local codes for further information.
- Contact your qualified service technician to install an outside air kit (if available) for the burner. An outside air kit allows ducting of outside air directly to the burner.

Table 2 Corrosive contaminants and likely locations

Products to avoid
Spray cans containing chloro/fluorocarbons
Permanent wave solutions
Chlorinated waxes/cleaners
Chlorine-based swimming pool chemicals
Calcium chloride used for thawing
Sodium chloride used for water softening
Refrigerant leaks
Paint or varnish removers
Hydrochloric acid/muriatic acid
Cements and glues
Antistatic fabric softeners used in clothes dryers
Chlorine-type bleaches, detergents, and cleaning solvents found in household laundry rooms
Adhesives used to fasten building products and other similar products
Areas likely to have contaminants
Dry cleaning/laundry areas and establishments
Swimming pools
Metal fabrication plants
Beauty shops
Refrigeration repair shops
Photo processing plants
Auto body shops
Plastic manufacturing plants
Furniture refinishing areas and establishments
New building construction
Remodeling areas
Garages with workshops



WARNING HOMEOWNER and SERVICE TECHNICIAN — read and follow completely.

Operation

SGO with float-type low water cutoff

1. If burner does not fire, check for:
 - Switch on boiler or additional shut-off switches turned off.
 - Fuses or breaker switch tripped.
 - Thermostat set below room temperature.
 - Fuel valves turned off.
 - Not enough oil in tank to supply burner.
 - No water in gauge glass.

2. Correct problems found in Step #1. If burner does not fire, press reset button on burner primary control only once. Repeated presses will deposit oil in combustion chamber.

⚠ DANGER Burner must never be fired when oil is in combustion chamber. Immediately call qualified service technician.

3. If burner still does not fire, call qualified service technician.

Figure 3 SGO boiler with float-type low water cutoff (see Figure 4, page 12 for probe-type low water cutoff)

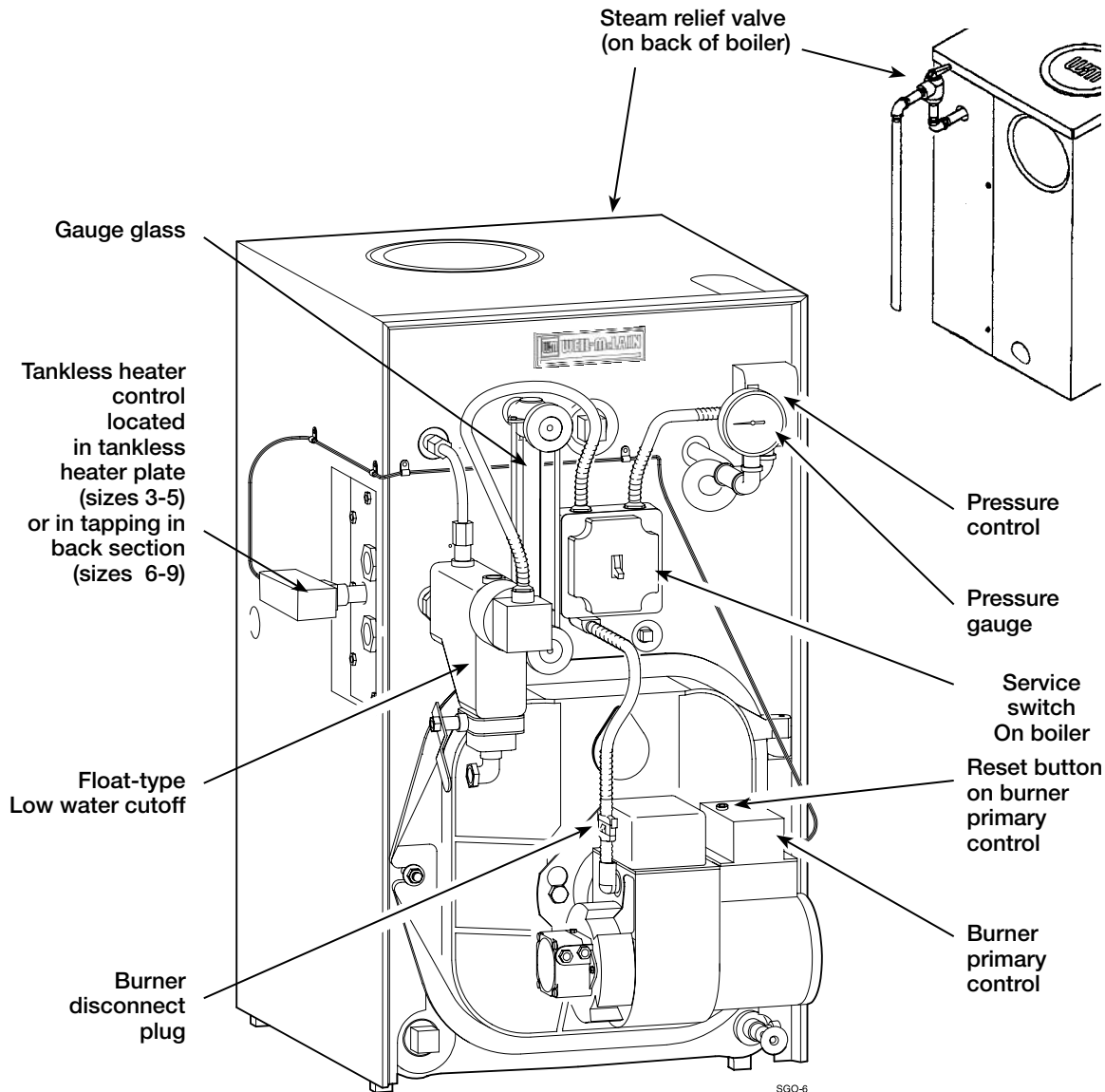



WARNING HOMEOWNER and SERVICE TECHNICIAN — read and follow completely.

Operation (continued)

SGO with probe-type low water cutoff

1. If burner does not fire, check for:
 - Service switch on boiler or additional switches turned off.
 - Fuses or breaker switch tripped.
 - Thermostat set below room temperature.
 - Fuel valves turned off.
 - Not enough oil in tank to supply burner.
 - No water in gauge glass.

2. Correct problems found in Step #1. If burner does not fire, press reset button on burner primary control only once. Repeated presses will deposit oil in combustion chamber.

⚠ DANGER Burner must never be fired when oil is in combustion chamber. Immediately call qualified service technician.

3. If burner still does not fire, call qualified service technician.

Figure 4 SGO boiler with probe-type low water cutoff (see Figure 3, page 11 for float-type low water cutoff)

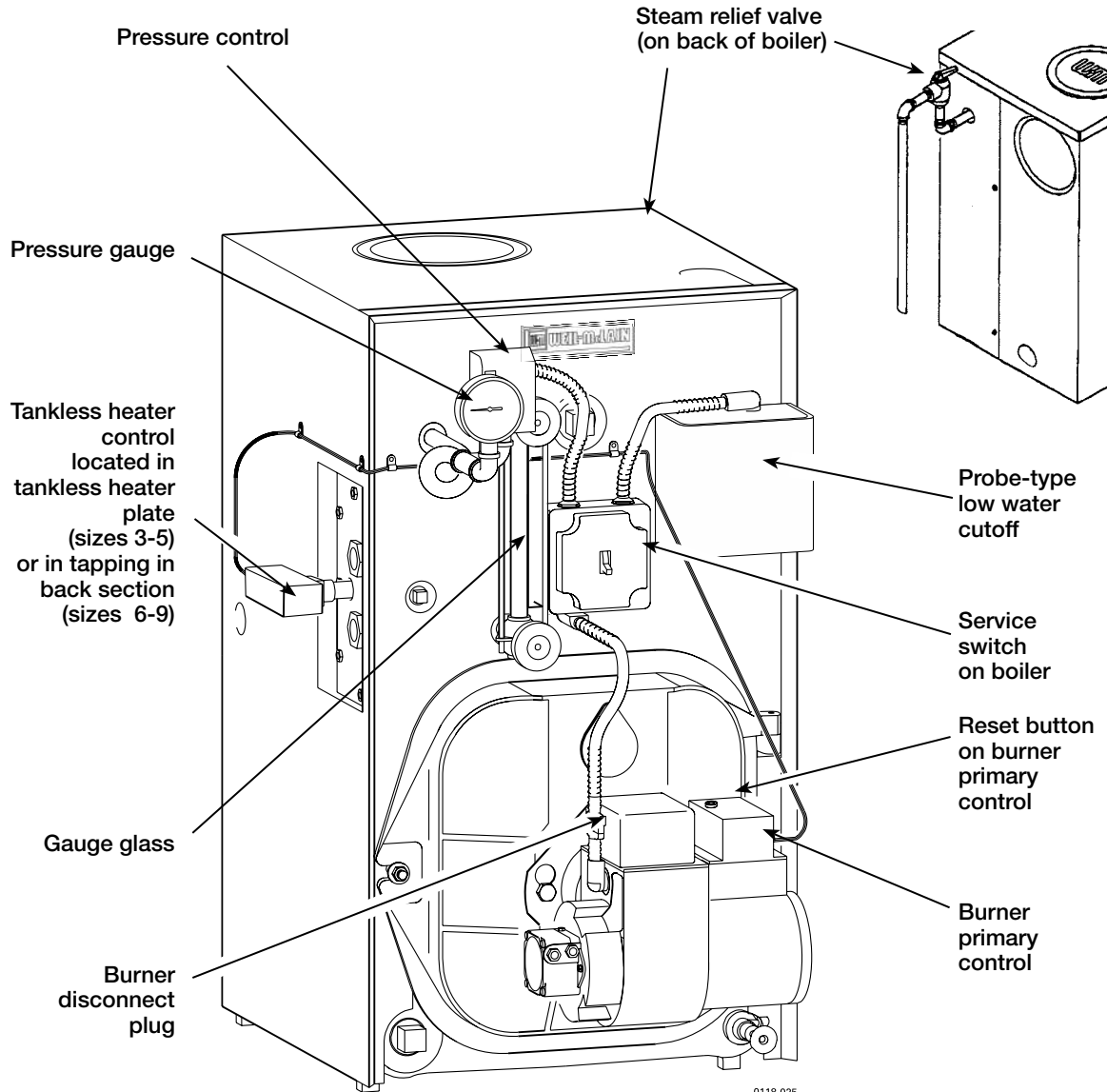

0118-025



▲WARNING SERVICE TECHNICIAN ONLY — read and follow completely.

Install boiler — packaged boilers only

Place boiler

1. Remove boiler from pallet.

NOTICE Do not drop boiler or bump jacket on floor or pallet. Damage to boiler can result.

▲WARNING Smaller sized boilers may be top heavy. Use caution when handling to avoid minor personal injury or property damage.

2. The boiler is shipped for back flue outlet. To change to top flue outlet (see Figure 5):
 - a. Remove the jacket cap and the 8.00" diameter piece of insulation that covers the vent opening from the top jacket panel.
 - b. Loosen two (2) screws holding flue cap strap to collector hood. Remove strap and flue cap from opening. Re-tighten screws.
 - c. Check rope placement inside flue cap. (Read **▲WARNING** under Step #5 below).
 - d. Loosen two (2) screws on back flue outlet. Set flue cap on outlet. Install strap by engaging slots in screws. Tighten screws. Make sure cap is securely installed.
 - e. Place the jacket cap insulation in the back opening of the boiler covering the flue cap.
 - f. Snap jacket cap in back outlet opening.

NOTICE Jacket cap and insulation disc must be in place on boiler to avoid requiring an 18" minimum clearance from back of boiler to combustible material.

3. Check level. Shim legs, if needed.
4. Check for secure placement of insulation on target wall, chamber floor and burner door.
5. Visually check:
 - a. Flue collector hood seal.
 - b. Burner mounting door seal.

▲WARNING Obtain gas-tight seal to prevent possible flue gas leakage and carbon monoxide emissions, which can lead to severe personal injury or death.

Tankless heater, if used

1. Remove tankless heater knockout in left side of jacket panel and, for SGO-6 only, tankless heater control knockout.
2. Remove tankless heater cover plate and gasket.
3. Install new gasket and tankless heater over studs around opening. Secure with 3/8" nuts.
4. Install tankless heater operating control where shown on page 25. If not furnished, use operating control with maximum 10°F differential.

Perform hydrostatic pressure test

1. Remove steam pressure gauge furnished with boiler. Install water pressure gauge for test only. Be sure gauge can handle test pressure.
2. Install air vent in tapping on top of boiler.
3. Remove pressure control and low water cutoff. Plug tappings.
4. Plug supply and return tappings.
5. Drain valve is already factory-installed.
6. Fill boiler. Vent all air. Pressure test boiler at 45-55 psig.

▲WARNING Do not leave boiler unattended. Cold water fill can expand and damage cast iron, resulting in severe personal injury, death or substantial property damage.

7. Check for maintained gauge pressure for more than 10 minutes. Visually check for leaks if gauge pressure drops.
8. Drain boiler. Repair leaks if found.

▲WARNING Using petroleum-based compounds to repair leaks can damage system components, resulting in property damage.

9. Retest boiler after repairing leaks.
10. Remove pressure gauge, air vent and plugs. Re-install steam pressure gauge, pressure control and low water cutoff furnished with boiler.

Figure 5 Change from back flue outlet to top flue outlet (optional)

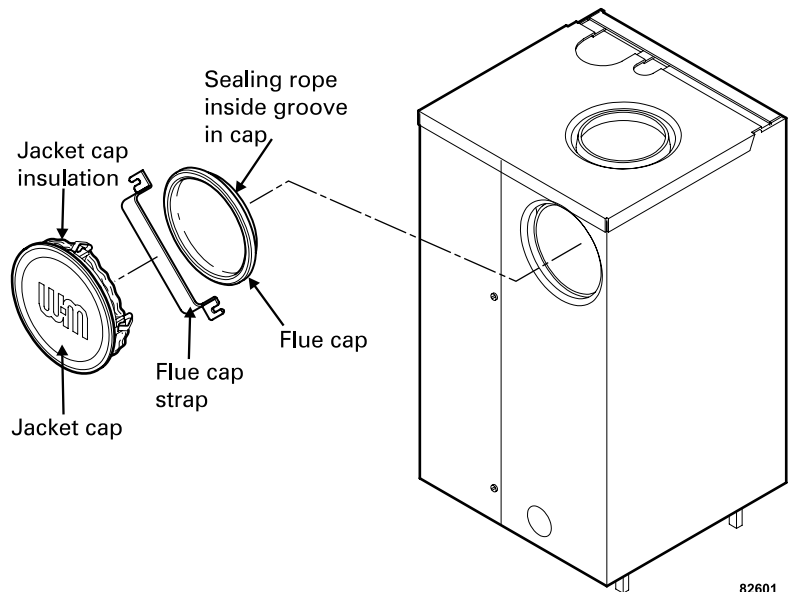

Instructions for Packaged boilers continued on page 18.

**▲WARNING** SERVICE TECHNICIAN ONLY — read and follow completely.

Install boiler – Semi-packaged and Knocked-down boilers only

▲WARNING Fiberglass wool and ceramic fiber materials are possible cancer hazards. See warning on page 48.

Place boiler

1. Semi-packaged SGO-3 through 6 — position on site.

▲CAUTION Smaller sized boilers may be top heavy. Use caution when handling to avoid minor personal injury or property damage.

- a. Boiler is shipped for back flue outlet. To change to top flue outlet (see Figure 6, page 15):
 - Remove the jacket cap and the 8.00” diameter piece of insulation that covers the vent opening from the top jacket panel.
 - Loosen two (2) screws holding flue cap strap to collector hood. Remove strap and flue cap from opening. Re-tighten screws.
 - Check rope placement inside flue cap. (Read **▲WARNING** under Step #3 at right).
 - Loosen two (2) screws on back flue outlet. Set flue cap on outlet. Install strap by engaging slots in screws. Tighten screws. Make sure cap is securely installed.
 - Place the jacket cap insulation disc in the back opening of the boiler covering the flue cap.
 - Snap jacket cap in back outlet opening.

NOTICE Jacket cap and insulation disc must be in place on boiler to avoid requiring an 18” minimum clearance from back of boiler to combustible material.

2. Knocked-down SGO-7, 8 & 9 — split the assembled block for easier handling (see Figure 6):
 - a. Open burner mounting door and using utility knife, slit floor insulation at joint to be separated.
 - b. Remove 5½” draw rod and the longest draw rod from each side. Pull block apart. Save draw rods, nuts, washers and sealing rings for reassembly.
 - c. Move divided block to location.
 - d. Clean port openings with clean rag.

▲CAUTION Do not use petroleum-based compounds to clean openings. Damage to system components can result causing property damage.

- e. Place rings in port openings. If ring slips out of groove, stretch ring gently for several seconds, then place in groove.
- f. Position sections so aligning lugs fit into sockets of next section. Make sure sealing rope is in good condition and in position.

- g. Oil threads on draw rods. Install washer and nut on end to be tightened. Use nut only on other end.
- h. With wrench at washer/nut end, uniformly tighten nuts starting with 5½” rod at large port, 5½” rod at small port, bottom long rod and finally top long rod.
- i. Torque on both 5½” rods and bottom long rod should be 50-60 ft. lbs.; long top rod should be 20-25 ft. lbs. Do not back-off nuts.
- j. Metal-to-metal contact should be made around port openings. If gap does exist, it should be less than .020”. Check with feeler gauge.
- k. If gap around port openings exceeds .020”, check for dirt on port openings, sockets or misaligned lugs. If corrections are made and gap still exists, contact our Technical Services group for assistance before continuing installation.

3. Knocked-down SGO-3 through 9 — install flue collector hood (see Figure 6):

▲WARNING Obtain gas-tight seal to prevent possible flue gas leakage and carbon monoxide emissions, leading to severe personal injury or death.

- a. Thread Tinnerman clip on screw so that clip fits snugly in notch of hold-down lug. Screw must not turn.
- b. Remove paper on sealing rope. Starting at back section near flue collar, position sealing rope around top of block with adhesive side to sections. Do not stretch rope. Make sure rope ends meet. Trim excess rope.
- c. Position flue collector hood on top of boiler sections and over screws and clips as shown in Figure 6.
- d. Install washers and nuts. Tighten nuts until collector hood makes contact with Tinnerman clip.
- e. Position flue cap
 - Back flue outlet boiler — Position flue cap and strap over opening in flue collector hood. Make sure rope in cap is in place and in good condition. Tighten strap to hood with screws provided.
 - Top flue outlet boiler — Position flue cap and strap over opening in back section. Make sure rope in cap is in place and in good condition. Tighten strap to boiler with screws provided in section. Install remaining screws in holes in flue collector hood.

4. Check level. Shim legs, if needed.

Tankless heater, if used

1. SGO-3 through 6 — remove knockout in left side jacket panel, and for SGO-6 only, remove tankless heater control knockout.
2. Remove tankless heater cover plate and gasket.
3. Install new gasket and tankless heater over studs around opening. Secure with 3/8” nuts.



▲WARNING SERVICE TECHNICIAN ONLY — read and follow completely.

Install boiler – Semi-packaged and Knocked-down boilers only (continued)

Figure 6 Change from back flue outlet to top flue outlet (optional)

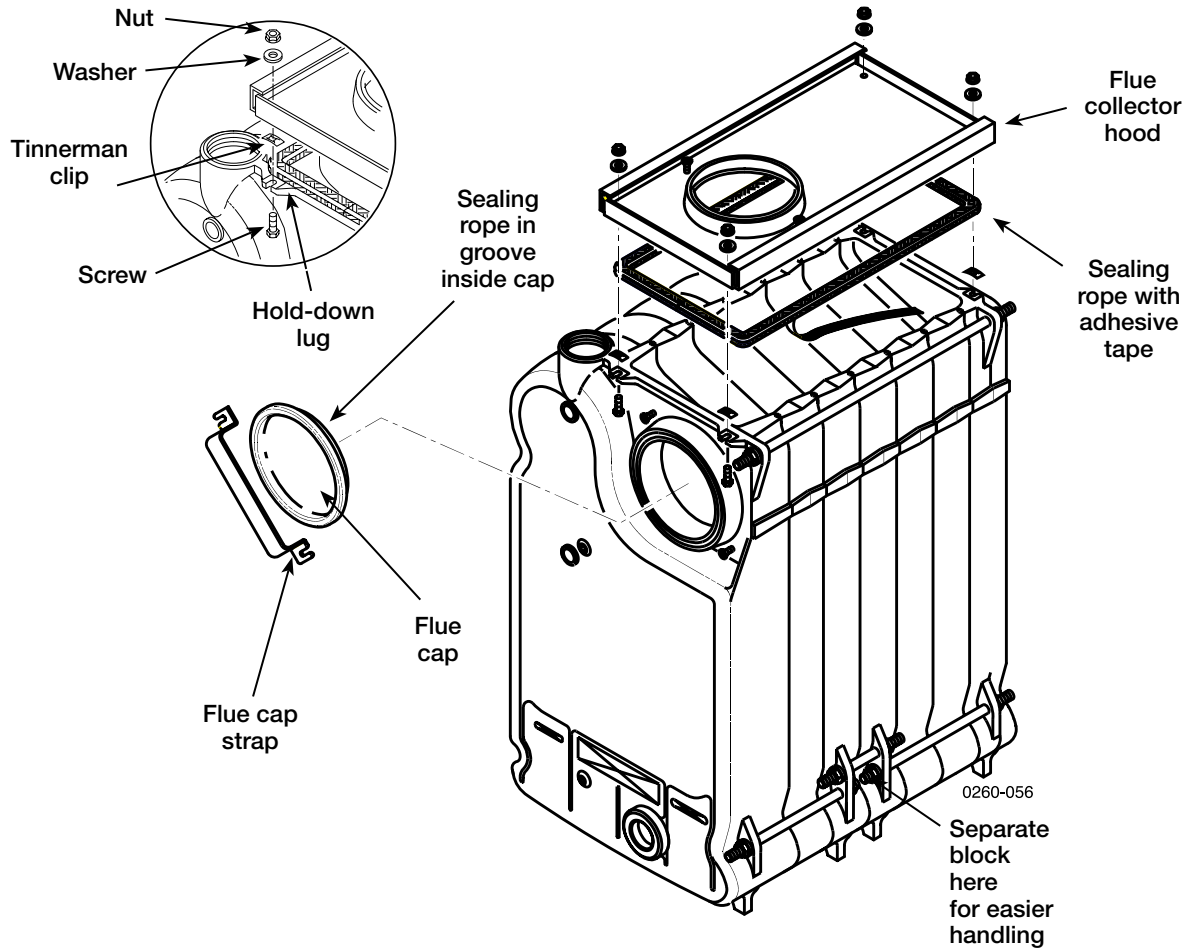



▲WARNING SERVICE TECHNICIAN ONLY — read and follow completely.

Install boiler – Semi-packaged and Knocked-down boilers only (continued)

Perform hydrostatic pressure test

1. Refer to Figure 7 and Control Tapping Table 3, to install:
 - a. Boiler drain.
 - b. Water pressure gauge (test only). Be sure gauge can handle test pressure.
 - c. Air vent in tapping on top of boiler.
 - d. Plugs in remaining tappings.
2. Fill boiler. Vent all air. Pressure test boiler at 45-55 psig.

▲WARNING Do not leave boiler unattended. Cold water fill could expand and damage cast iron, resulting in severe personal injury, death or substantial property damage.

3. Check for maintained gauge pressure for more than 10 minutes. Visually check for leaks if gauge pressure drops.
4. Drain boiler. Repair leaks if found.

▲CAUTION Do not use petroleum-based compounds to repair leaks. Damage to system components can result, causing property damage.

5. Re-test boiler after repairing leaks.
6. Remove pressure gauge, air vent and plugs from tappings used for controls.
7. Visually check:
 - a. Sealing rope placement
 - b. Metal-to-metal contact around port openings.
 - c. Flue collector hood seal.
 - d. Burner mounting door seal.

▲WARNING Obtain gas-tight seal to prevent possible flue gas leakage and carbon monoxide emissions, which can lead to severe personal injury or death.

Install jacket (Knocked-down boilers only)

Before installing jacket, remove burner mounting door. See jacket instructions for details.

Install boiler controls

See control tapping location, Figure 7, control tappings, Table 3, and Figure 8 or Figure 9 on page 17 to install controls.

1. Do not use Teflon tape to install probe-type low water cutoff; it will cause low water cutoff to work improperly.
2. Install tankless heater control if tankless heater is used. If not furnished, use operating control with maximum 10°F differential.
3. Make sure gauge glass is last control installed to prevent breakage.
4. Affix Consumer Protection (CP) number label(s) on jacket front panel.

Table 3 Control tappings (see Figure 7, page 17 for locations)

Location	Size	Function
A1	1½"	Skim tapping
A2	2½"	Supply piping (sizes 3 - 9)
A3	2½"	Supply piping (sizes 6 - 9)
B1	1½"	Plugged
B2	2"	Return piping
E1 & E2	½"	Float LWCO
E1	½"	Steam pressure gauge and limit Control when using probe LWCO
E2	½"	Plugged when using probe LWCO
H	¾"	Drain valve
L	¾"	Steam pressure gauge and limit Control when using float LWCO Plugged when using probe LWCO)
P	¾"	Probe LWCO (plugged when using float LWCO)
R	¾"	Relief valve
S1 & S2	½"	Gauge glass
U1	1"	Indirect-fired water heater/ hot water baseboard supply
U2	¾"	Operating control for tankless heater (sizes 6-9) or operating control for indirect-fired water heater (sizes 3-9)
U3	¾"	Operating control for tankless heater (located in heater plate — sizes 3-5)



WARNING SERVICE TECHNICIAN ONLY — read and follow completely.

Install boiler – Semi-packaged and Knocked-down boilers only (continued)

Figure 7 Control tapping locations (for use with Table 3, page 16)

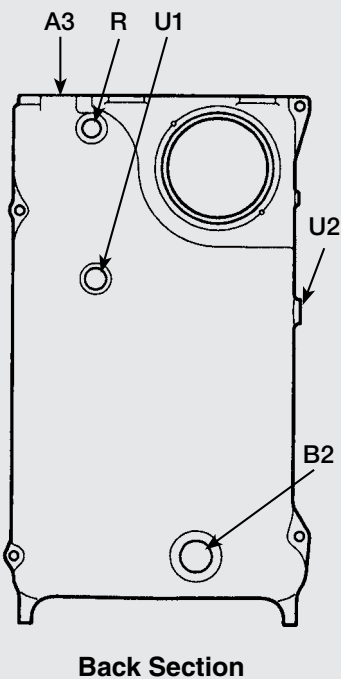
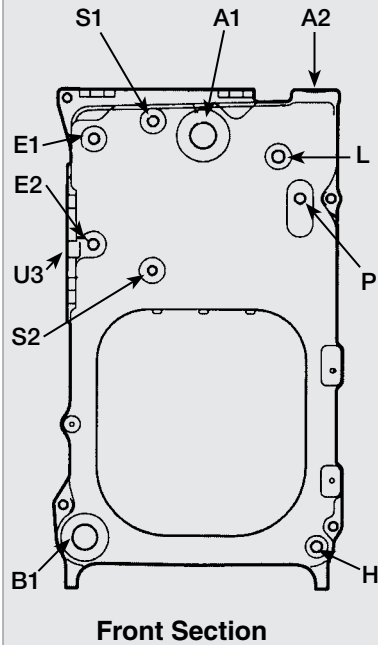

Figure 8 Steam boiler controls with float-type LWCO (optional tankless heater control)

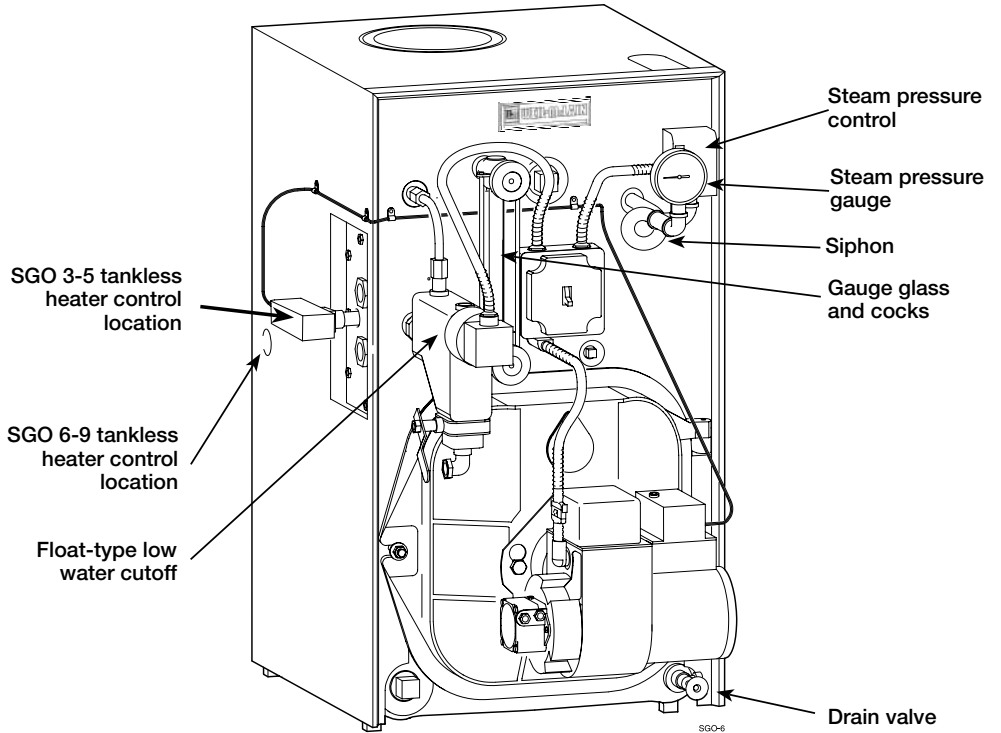
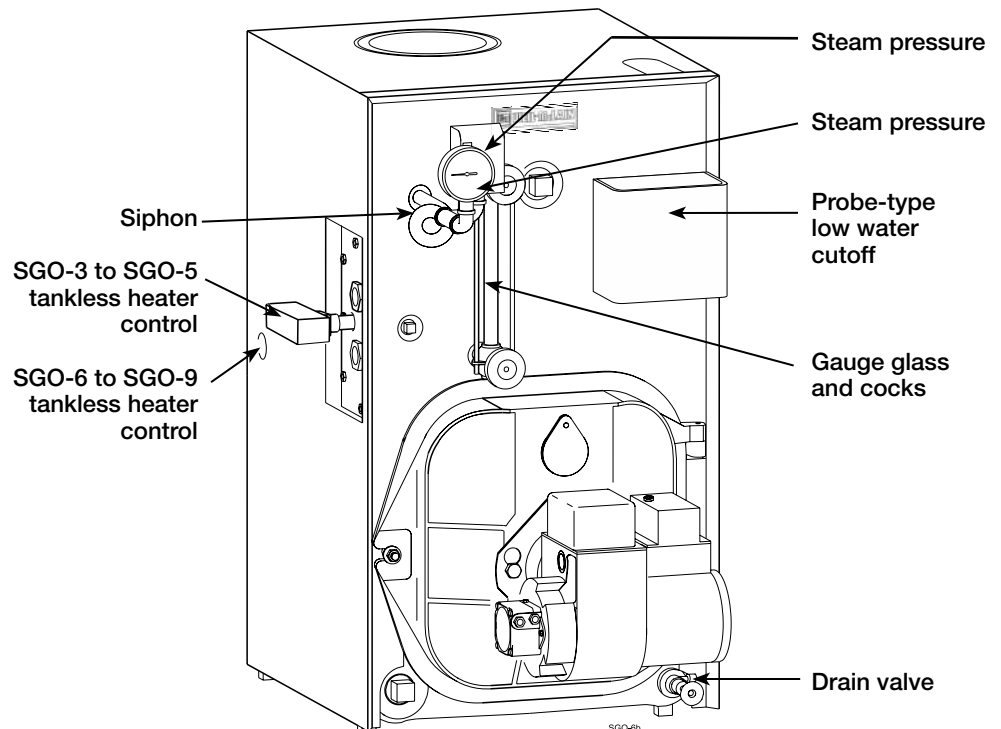

Figure 9 Steam boiler controls with probe-type LWCO (optional tankless heater control)





▲WARNING SERVICE TECHNICIAN ONLY — read and follow completely.

Install burners and chimney — all boilers

Install burner

(also refer to instructions packed with burner)

NOTICE Use only burners specified for use on Weil-McLain oil boilers. Contact individual burner manufacturers for proper burner selections.

For burners with OEM welded flanges:

1. Secure mounting flange and gasket to burner mounting door. Use three (3) bolts provided.
2. Open door to verify secure placement of insulation on target wall, chamber floor and burner mounting door.
3. Securely close door and tighten nut.

For burners without OEM welded flanges:

1. Secure universal mounting flange and gasket to burner mounting door. Use three (3) bolts provided.
2. Secure burner on flange with three (3) bolts.
3. Position burner so end of air tube is level to 1½-degree tilt down toward chamber. Open door to verify burner position. End of air tube should be flush to ¼" recessed from inside wall of burner door refractory. Check for secure placement of insulation on target wall, chamber floor and burner mounting door.
4. Securely close door and tighten nut.

General chimney requirements

Designed for natural draft firing. Connect boiler to vertical chimney.

▲DANGER Insufficient draft can cause flue gas leakage and carbon monoxide emissions, which will lead to severe personal injury or death.

Use vent material approved by local codes for oil-fired burners. In their absence, refer to:

- NFPA 31- latest edition, Installation of Oil-Burning Equipment.
- NFPA 211- latest edition, Standard for Chimneys, Fireplaces, Vents and Solid Fuel Burning Appliances.
- In Canada, refer to CSA B139, Installation Code for Oil-Burning Equipment.

NFPA 211 requires chimney to be lined before connected to boiler.

Table 4 Minimum chimney sizes

Boiler model number	Minimum breeching diameter (Note 3)	Minimum chimney size		Minimum chimney height
		Rect.	Round	
SGO-3	5"	8" x 8" (Note 1)	6"	15'
SGO-4	6"			
SGO-5	6"	8" x 8" (Note 1)	7"	15'
SGO-6	7"			
SGO-7	7"			
SGO-8	7"	8" x 12" (Note 2)	7"	20'
SGO-9				

NOTES:

1. 6¾" x 6¾" inside liner.
2. 6½" x 10½" inside liner.
3. Flue collar on boiler is 7" diameter.

▲DANGER Inspect existing chimney before installing new boiler. Failure to do any of the following will result in severe personal injury or death.

- Clean chimney, including removal of blockage.
- Repair or replace damaged pipe or liner.
- Repair mortar and joints.

To prevent downdrafts, extend chimney at least 3 feet above highest point where it passes through roof and 2 feet higher than any portion of building within 10 feet. Increase chimney cross-sectional area and height at least 4% per 1,000 feet above sea level.

- Minimum clearances from vent pipe to combustible material:
 - 6 inches — Type "L" double-wall vent
 - 9 inches — Single-wall vent
- Minimum chimney sizes should be used.

NOTICE Oversized chimneys, outside masonry chimneys and/or derated inputs can result in condensation in chimney.

Connect breeching

Connect breeching

▲WARNING Long horizontal breechings, excessive number of tees and elbows, or other obstructions restricting combustion gas flow can result in possibility of condensation, flue gas leakage and carbon monoxide emissions, which can lead to severe personal injury or death.

1. Install two (2) flue pipe brackets.
2. Connect full-sized breeching when possible. See Minimum Chimney Size Table 4.
 - Back outlet — see Figures 10 and 11, page 19.
 - Top outlet — see Figures 13 and 12, page 19.
3. Connection must be made above bottom of chimney to avoid blockage. Breeching must not enter chimney far enough to cause obstruction. Use thimble or slip joint where breeching enters chimney to allow removal for cleaning.
4. When burner and boiler are properly installed, draft over fire will be approximately -0.01" to -0.02" W.C. Install barometric control in breeching, per control manufacturer's instructions, when excess draft needs to be relieved or to comply with applicable codes and regulations. Use draft gauge to adjust proper opening.
5. An induced draft fan for the chimney may be necessary if:
 - Excessive resistance to flow of combustion gases can be expected.
 - Cross-sectional area of chimney is smaller than minimum recommended.
 - Chimney height is less than recommended.

▲WARNING Seal all vent joints. Interlock burner with fan operation.

6. Boiler models SGO-3 through SGO-7 require the installation of the Field Controls OVD-7 damper, Weil-McLain part number 381-800-515, which is provided with Packaged boilers, sold separately for Semi-packaged and Knocked-down boilers. Refer to Figures 10 and 13, page 19.



WARNING SERVICE TECHNICIAN ONLY — read and follow completely.

Connect breaching (continued)

Figure 10 Back outlet breaching connection for SGO-3 through 7 with OVD damper.

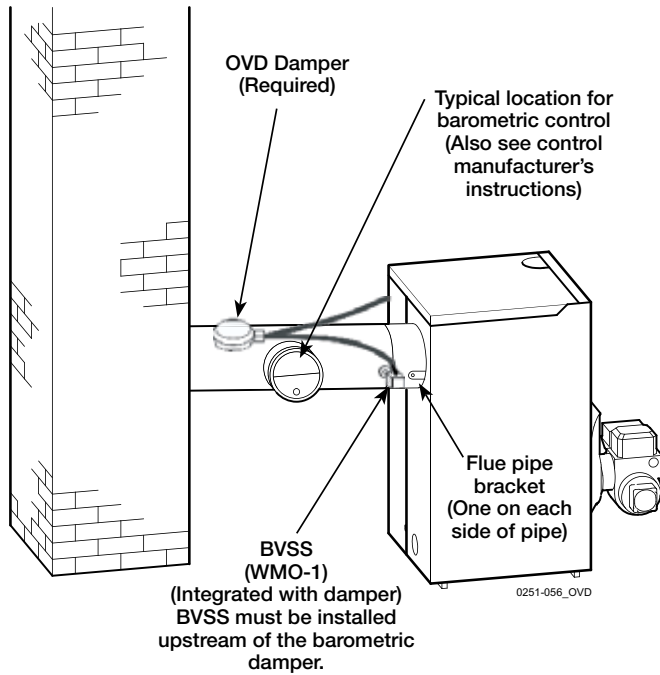

Figure 11 Back outlet breaching connection for SGO-8 and SGO-9

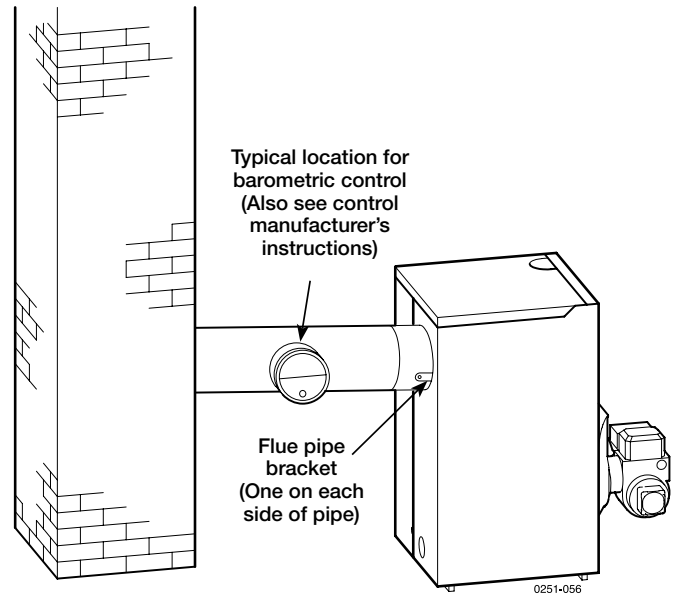

Figure 13 Top outlet breaching connection for SGO-3 through 7 with OVD damper.

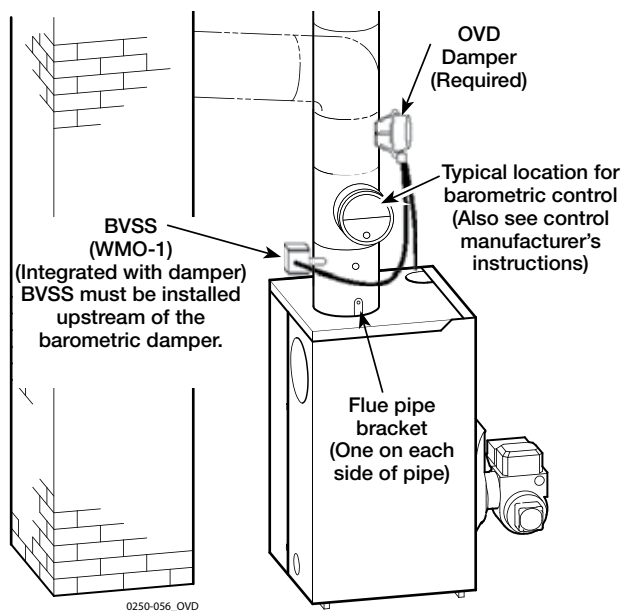
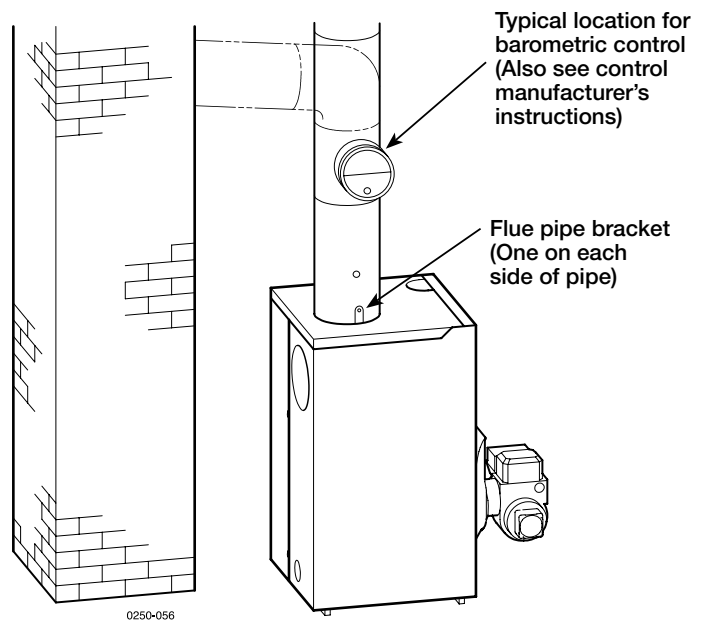

Figure 12 Top outlet breaching connection for SGO-8 and SGO-9





▲WARNING SERVICE TECHNICIAN ONLY — read and follow completely.

Connect steam piping

General piping information

- Hartford Loop piping arrangement and wet return are required for steam boilers.
- Maintain 24-inch minimum from waterline to bottom of header (minimum 50⁷/₈" from floor or top of foundation).
- When using condensate receiver, feed pump must be energized by boiler-mounted pump control.
- Use swing joints in steam piping.
- If installation is to comply with ASME or Canadian requirements, an additional pressure limit control is needed. Install control between existing pressure control and pressure gauge. Control must be installed with siphon (supplied with boiler) between control and boiler. Set control to minimum of 5 psi above set point of existing control and maximum setting of 15 psi. Wire as shown on boiler wiring diagram.

Install piping

1. See Table 5 at right and Figure 14, page 21 or Figure 15, page 22.

▲WARNING Improperly piped systems or undersized piping can contribute to erratic boiler operation and possible boiler or system damage. Piping system must be installed as shown, using minimum pipe sizes shown. Consult your Weil-McLain distributor or sales office before installing alternate piping.

2. Install relief valve vertically in “R” tapping on back of boiler. See Figure 14 or Figure 15 and also refer to tag attached to relief valve for manufacturer’s instructions.

▲WARNING Pipe relief valve discharge line near floor close to floor drain to eliminate potential of severe burns. Do not pipe to any area where freezing could occur. Do not plug, valve or place any obstruction in discharge line.

3. Float-type low water cutoff only — install blow down line in bottom of cutoff. See Figure 14 or Figure 15 and also refer to low water cutoff manufacturer’s instructions for details.

▲WARNING Pipe blow down line near floor close to floor drain to eliminate potential of severe burns. Do not pipe to any area where freezing could occur. Do not plug, valve or place any obstruction in discharge line.

To connect SGO boilers to indirect-fired water heaters

Install and wire per water heater manual provided with water heater.

If boiler already has a tankless heater installed:

- Remove tankless heater and install cover plate.

OR

- Leave tankless heater installed. Drain coil and remove piping. Do not plug holes in tankless heater front plate.

Table 5 Steam piping size table

One and two-pipe systems				
Boiler Model Number	Riser Pipe Size (Note 1)		Header Pipe Size “H” (Note 2)	Equalizer Pipe Size “J”
	A	B		
SGO-3	2½" (Note 3)	—	2½"	1½"
SGO-4	2½" (Note 3)	—	2½"	1½"
SGO-5	2½"	—	3"	1½"
SGO-6	2½"	2½"	3"	1½"
SGO-7	2½"	2½"	3"	1½"
SGO-8	2½"	2½"	3"	1½"
SGO-9	2½"	2½"	3"	1½"

One-pipe counter flow systems				
SGO-3	2½"	—	2½"	1½"
SGO-4	2½"	—	2½"	1½"
SGO-5	2½"	—	3"	1½"
SGO-6	2½"	2½"	4"	1½"
SGO-7	2½"	2½"	4"	1½"
SGO-8	2½"	2½"	4"	1½"
SGO-9	2½"	2½"	4"	1½"
Note 1	Based on ASHRAE Fundamentals Handbook recommendations, allowing ½ oz. pressure drop at 0 psig.			
Note 2	Based on ASHRAE Fundamentals Handbook recommendations, allowing 2 oz. pressure drop per 100 feet of pipe at 3.5 psig. Maintain minimum 24" height from waterline to bottom of header.			
Note 3	Can be reduced to 2".			



WARNING SERVICE TECHNICIAN ONLY — read and follow completely.

Connect steam piping (continued)

Figure 14 Steam piping for sizes 3 through 5 (see Figure 15, page 22, for sizes 6 through 9)

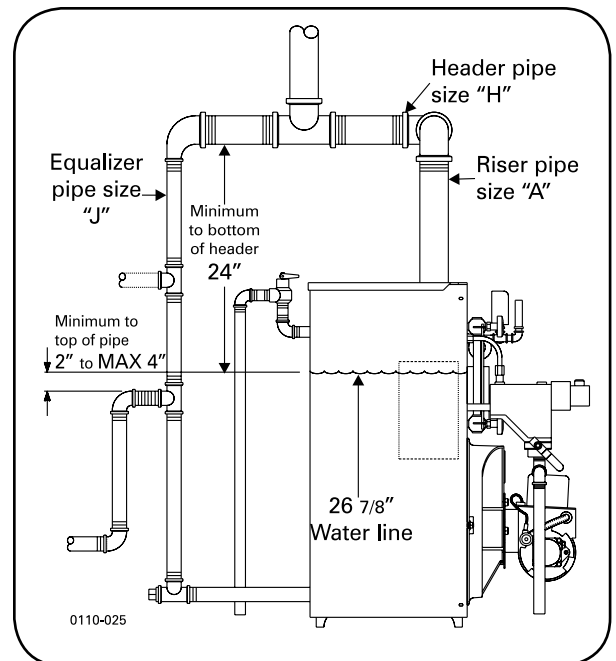
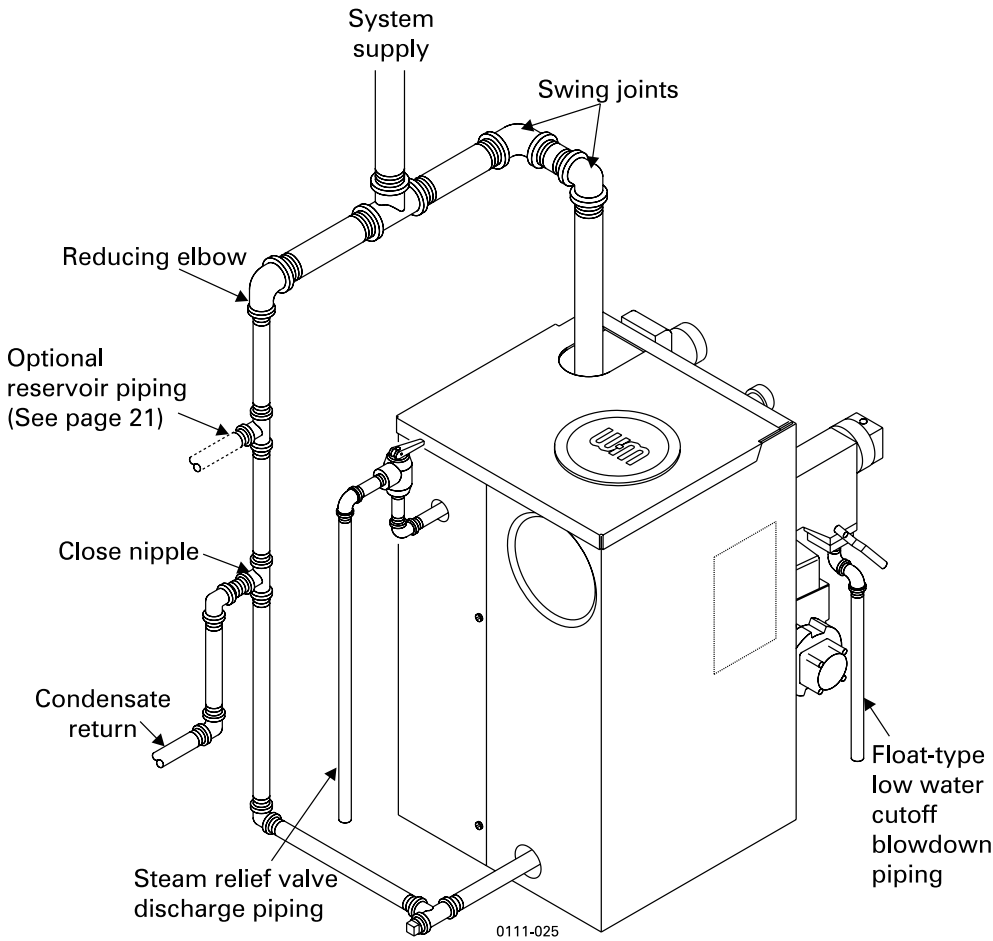



WARNING SERVICE TECHNICIAN ONLY — read and follow completely.

Connect steam piping (continued)

Figure 15 Steam piping for sizes 6 through 9 (see Figure 14, page 21 for sizes 3 through 5)

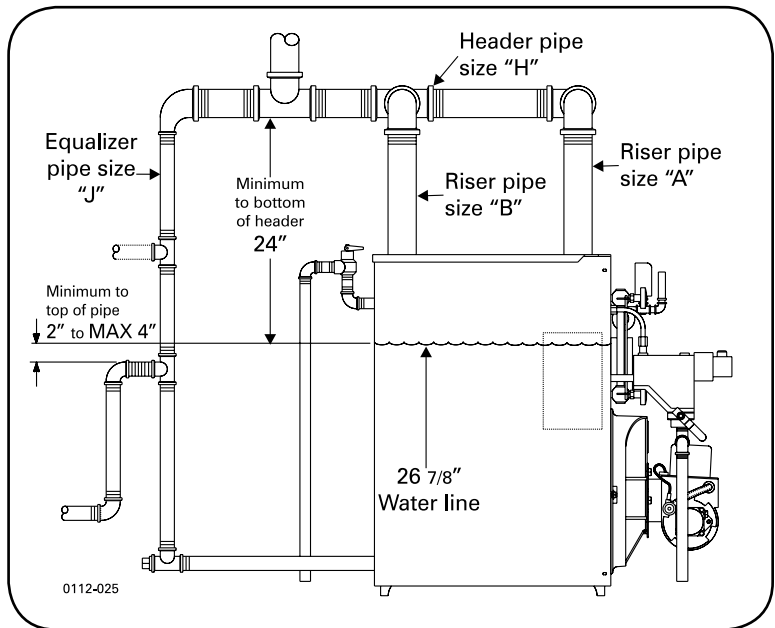
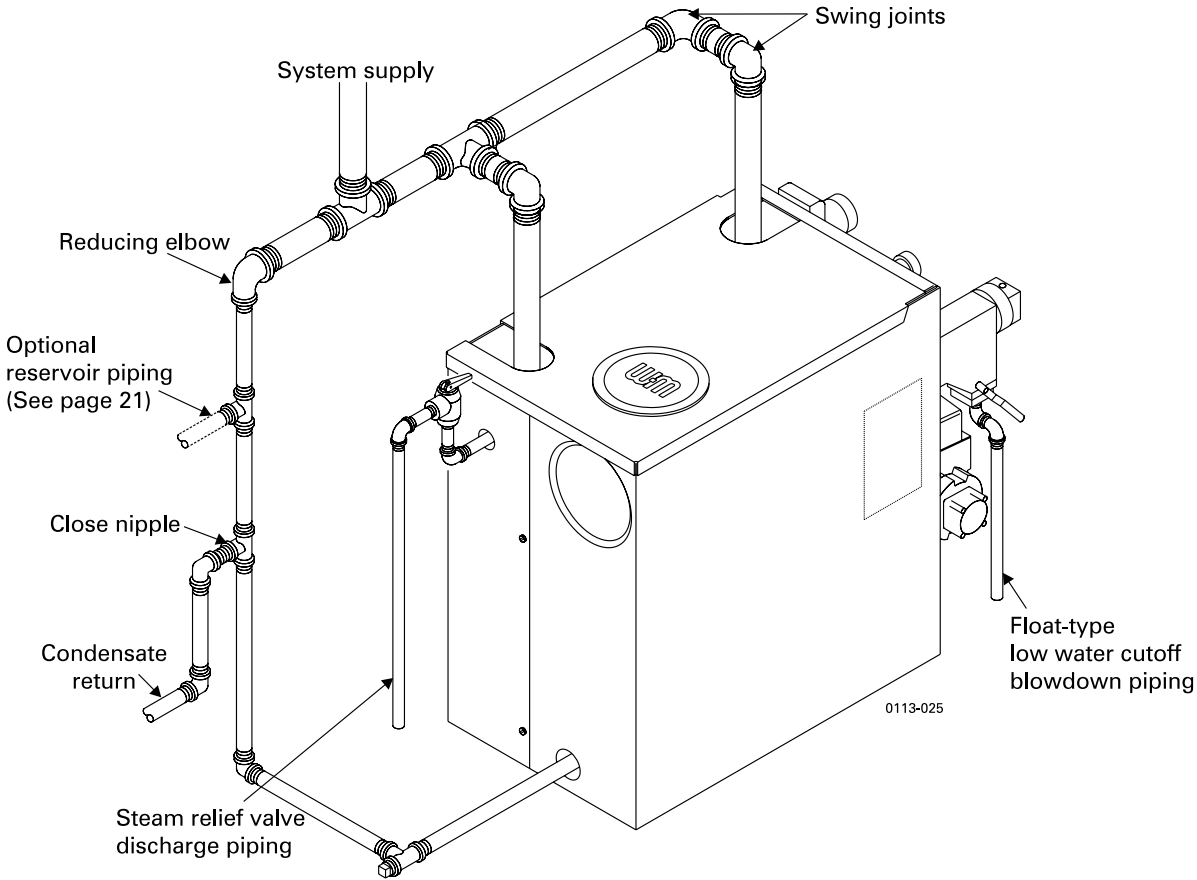



WARNING SERVICE TECHNICIAN ONLY — read and follow completely.

Connect steam piping (continued)

Figure 16 Typical piping (one riser shown on boiler)

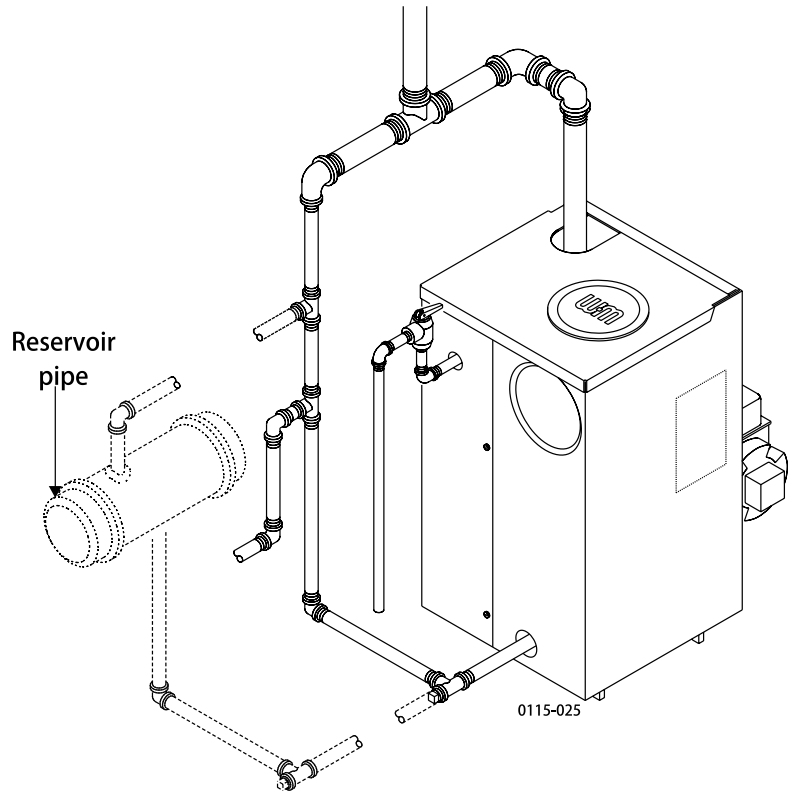
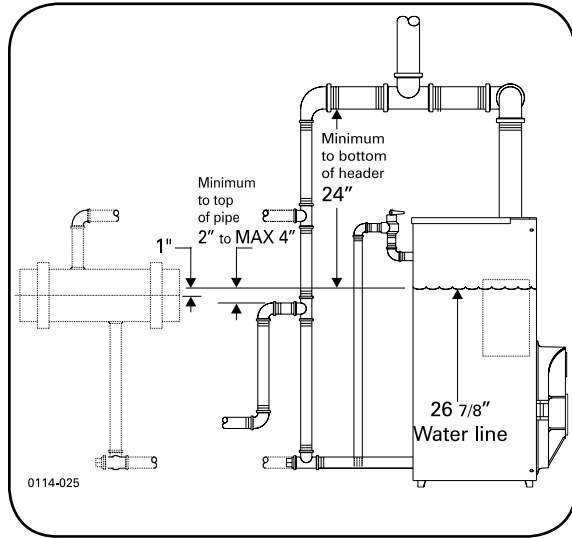

Optional reservoir piping

Modern steam boilers are designed to steam for less time than older, larger boilers. When replacing an older steam boiler, the system condensate return time may be longer than the steaming time. This can cause the following problems:

- Boilers fitted with an automatic water feed could overflow.
- Units fitted with only a low water cutoff would shut down and cycle while waiting for condensate to return.

To size and install reservoir piping :

1. Pipe boiler as shown on page 20 through page 22.
2. Use 8" diameter reservoir pipe.
3. Locate centerline of reservoir pipe 1" below 26 7/8" boiler waterline.

Table 6 Condensate receiver capacity

Boiler Model	Gross Output lbs steam per hour	Gallons condensate per hour	Minimum condensate receiver capacity – gal.				Recommended condensate feed pumping rate gpm at 15 psi
			15 Min.* Boiler operation	30 Min.* Boiler operation	45 Min.* Boiler operation	60 Min.* Boiler operation	
SGO-3	114	14	4	8	12	16	0.5
SGO-4	150	18	5	11	16	22	0.6
SGO-5	180	22	6	13	19	26	0.7
SGO-6	216	26	8	16	23	31	0.9
SGO-7	246	30	9	18	27	35	1.0
SGO-8	274	33	10	20	30	39	1.1
SGO-9	303	36	11	22	33	44	1.2

* Maximum time to when condensate returns to boiler.



▲WARNING SERVICE TECHNICIAN ONLY — read and follow completely.

Connect tankless heater piping

▲DANGER Hot Water Can Scald!

- Consumer Product Safety Commission and some states recommend domestic hot water temperature of 130°F or less.
- When installing an automatic mixing valve, selection and installation must comply with valve manufacturer’s recommendations and instructions.
- Water heated to a temperature suitable for clothes washing, dish washing and other sanitizing needs will scald and cause injury.
- Children, elderly, infirm or physically handicapped persons are more likely to be injured by hot water. Never leave them unattended in or near a bathtub, shower or sink. Never allow small children to use a hot water faucet or draw their own bath. If anyone using hot water in the building fits this description, or if state laws or local codes require certain water temperatures at hot water faucets, take special precautions:
 - Install automatic mixing valve set according to those standards.
 - Use lowest practical temperature setting.
 - Check water temperature immediately after first heating cycle and after any adjustment.

To pipe tankless heater

1. Size piping no smaller than tankless heater inlet and outlet.
2. Following controls (furnished by others) must be installed:
 - a. **Automatic mixing valve.** See Figure 17. (Read **▲DANGER** at left.)
 - b. Flow regulating valve. Size according to intermittent draw of tankless heater. See Table 7 below. Follow valve manufacturer’s instructions to install.
3. Additional anti-scald devices may be installed at each hot water faucet, bath and shower outlet.
4. In hard water areas, soften cold domestic supply water to heaters to prevent lime build-up.



Tankless water heaters for SGO boilers have been tested and certified by CSA Group (certificate # 2552127).

▲WARNING

Studies have indicated that dangerous bacteria can form in potable water distribution systems if certain minimum water temperatures are not maintained. Contact local health department for more information.

Table 7 Tankless heater ratings

Boiler model number	Heater number	Intermittent draw ratings (gpm)*	Inlet and Outlet tapping sizes
SGO-3	35-S-29	3.25	3/4"
SGO-4	35-S-29	3.50	3/4"
SGO-5	35-S-29	3.75	3/4"
SGO-6	35-S-29	4.00	3/4"
SGO-7	35-S-29	4.00	3/4"
SGO-8	35-S-29	4.00	3/4"
SGO-9	35-S-29	4.00	3/4"
NOTES:	<ol style="list-style-type: none"> 1. To avoid supplying steam to system during summer tankless operation, raise water level to one inch above normal water line. 2. Gallons of water per minute heated from 40°F to 140°F with 200°F boiler water temperature. Tested in accordance with AHRI testing and rating standard for indirect tankless water heaters tested with boilers. 		



WARNING SERVICE TECHNICIAN ONLY — read and follow completely.

Connect tankless heater piping (continued)

Figure 17 Tankless heater piping

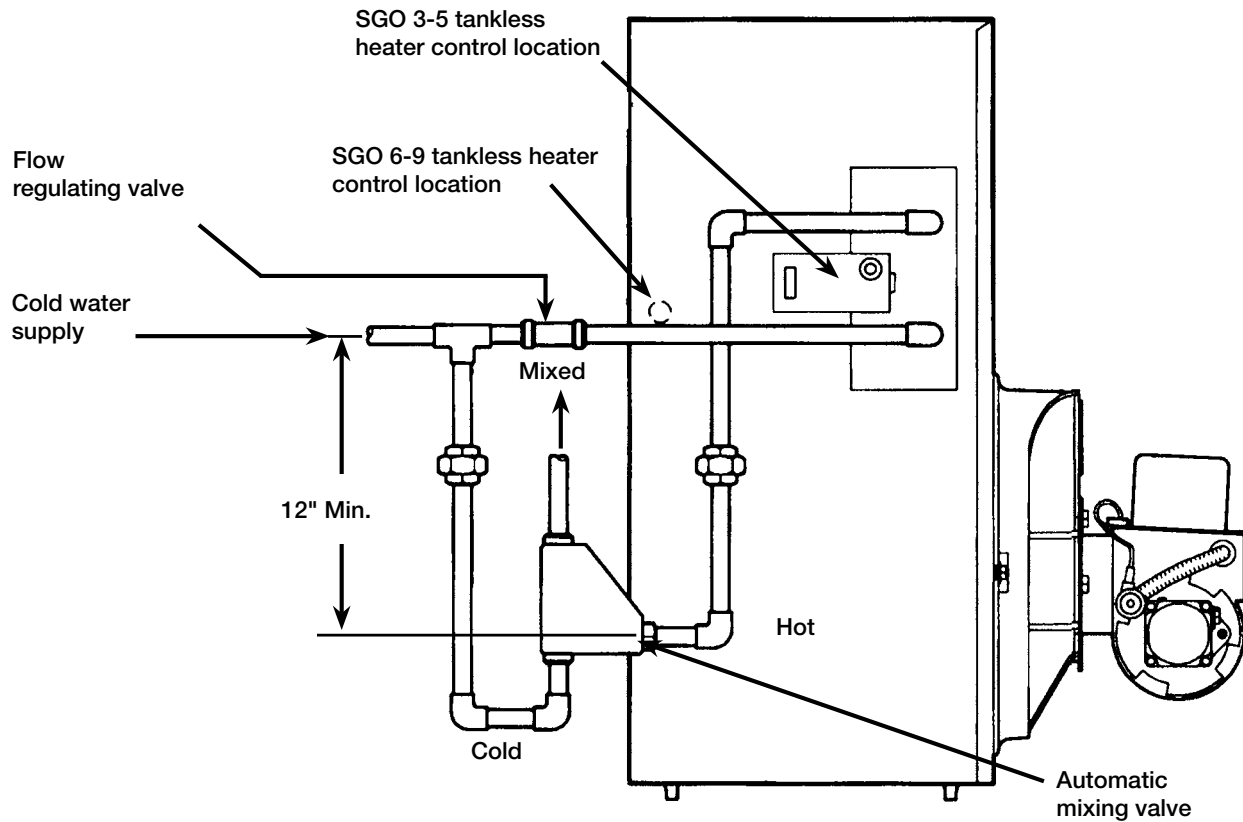

These single wall heat exchangers comply with National Standard Plumbing Code provided that:

- Boiler water (including additives) is practically non-toxic, having a toxicity rating or class of 1, as listed in Clinical Toxicology of Commercial Products.
- Boiler water pressure is limited to max. 15 psig by approved steam relief valve.

**▲WARNING** SERVICE TECHNICIAN ONLY — read and follow completely.

Connect wiring — general information

General wiring requirements

▲WARNING **ELECTRICKSHOCK HAZARD**— Can cause severe personal injury or death if power source, including service switch on boiler, is not disconnected before installing or servicing.

Installations must follow these codes:

- National Electrical Code, ANSI/NFPA 70, — latest edition and any additional national, state or local codes.
- In Canada, CSA C22.1 Canadian Electrical Code Part One — latest edition and any local codes.
- Wiring must be NEC Class 1 — latest edition. If original wire as supplied with boiler must be replaced, type 105°C wire or equivalent must be used. Supply wiring to boiler and additional control wiring must be 14 gauge or heavier.
- Provide electrical ground at boiler as required by codes.

Thermostat wiring

- Install thermostat on inside wall away from influences of drafts, hot or cold water pipes, lighting fixtures, television, sun rays or fireplaces.
- Follow instructions with thermostat. If it has a heat anticipator, set heat anticipator in thermostat to match power requirements of equipment connected to it. Boiler wiring diagrams give setting for standard equipment.

Junction box (furnished)

- Junction box houses electrical connections for all boiler components.
- Packaged boilers have harnesses furnished.
- For Semi-packaged and Knocked-down boilers, trim kits are furnished with burner and limit harnesses.
- All field-provided high voltage wiring must be sheathed in flexible metal conduit.
- Connect incoming line voltage “HOT” wire to service switch, and neutral wire to white wire. Field-install equipment ground wire to green wire with wire nut.

- Service switch (15 amp) is provided with boiler. For Semi-packaged and Knocked-down boilers — install switch as shown.
- Some local codes may require an emergency shut-off switch installed at a location away from boiler. Follow local codes.

Burner wiring

- Burner wire harness incorporates a disconnect plug, providing a convenient way to disconnect wiring when burner mounting door is opened.
- All Packaged boilers have a power disconnect plug installed on the service switch junction box.
- The burner is provided with a burner disconnect plug as shown in Figure 20, page 29, or Figure 23, page 31. For burners in which the disconnect plug is not factory-wired, connect the threaded conduit coupling of the disconnect plug wire harness (P/N 591-391-850, included in steam trim carton) to the burner housing and route the wires to make all connections in burner junction box as shown in boiler wiring diagram.

High temperature limit

- To comply with ASME, UL 726 or Canadian requirements, an additional high temperature limit is needed.
- Install the secondary control in the supply piping between boiler and isolation valve.
- Set the control to a minimum of 20°F above the set point of the combination control.
- The maximum allowable set point is 220°F.
- Wire the control as shown on page 28 (float-type LWCO) or page 30 (probe-type LWCO).



WARNING SERVICE TECHNICIAN ONLY — read and follow completely.

Connect wiring — general information (continued)

Blocked vent shutoff switch

WARNING **Electric shock hazard** – Turn off electrical power supply at service entrance panel before making any electrical connections to avoid possible electric shock hazard. Failure to do so can cause severe personal injury or death.

NOTICE In Canada, a blocked vent shutoff switch kit must be installed (see replacement parts list page 42). See Figure 28.

When using the OVD damper kit, the BVSS is required, and is integrated into the damper harness wiring.

When using the BVSS without the OVD damper, the BVSS is wired directly to the junction box as follows.

The BVSS wiring diagram in Figure 24, page 31 shows boiler wiring up to the burner disconnect. For additional information, refer to manufacturer’s installation instructions.

After installing BVSS switch, proceed as follows

1. Disconnect power.
2. Install BVSS Switch Wiring Harness (P/N 591-391-942, which is included in BVSS kit P/N 591-624-650) as follows:
 - a. Remove cover from BVSS Box.
 - b. Install straight fitting end of the harness on the BVSS Box. Install elbow (90°) end fitting on the Boiler Junction Box (see Figure 18).
 - c. Install both the fork ends to the screw terminals on the BVSS Switch as per the wiring diagram, (see Figure 21, page 29).
 - d. Replace BVSS box cover.

To wire blocked vent shutoff switch, see:
 Figure 19, page 28 for float-type LWCO
 Figure 22, page 30 for probe-type LWCO

Figure 18 Blocked vent shutoff switch installation

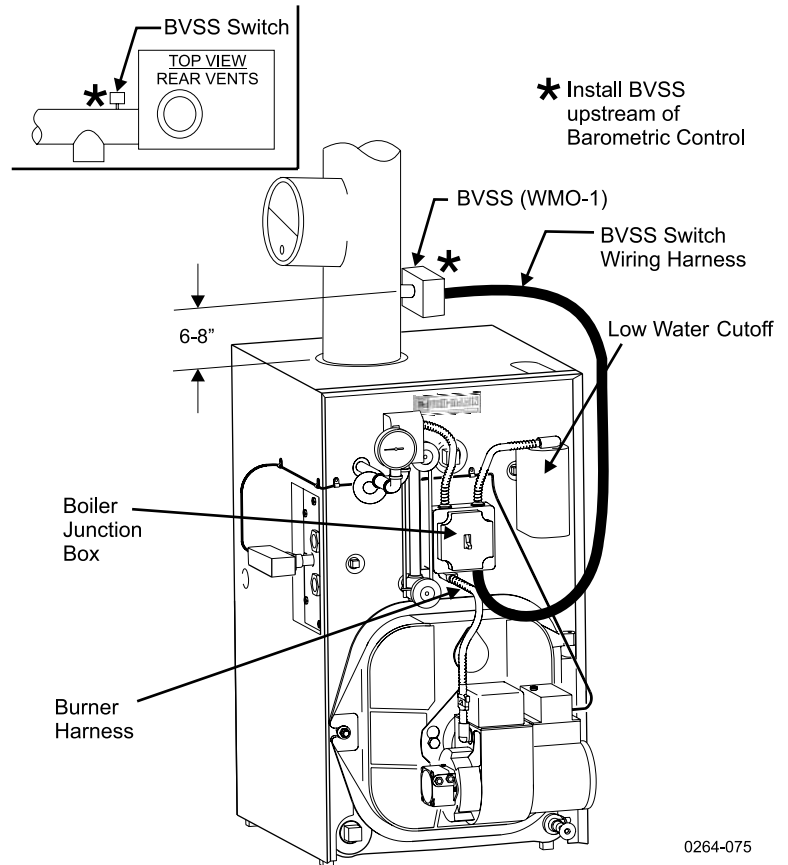

0264-075



WARNING SERVICE TECHNICIAN ONLY — read and follow completely.

Connect wiring (Float-type LWCO)

Figure 19 Boiler wiring for float-type LWCO — see Figure 20, page 29 for component locations

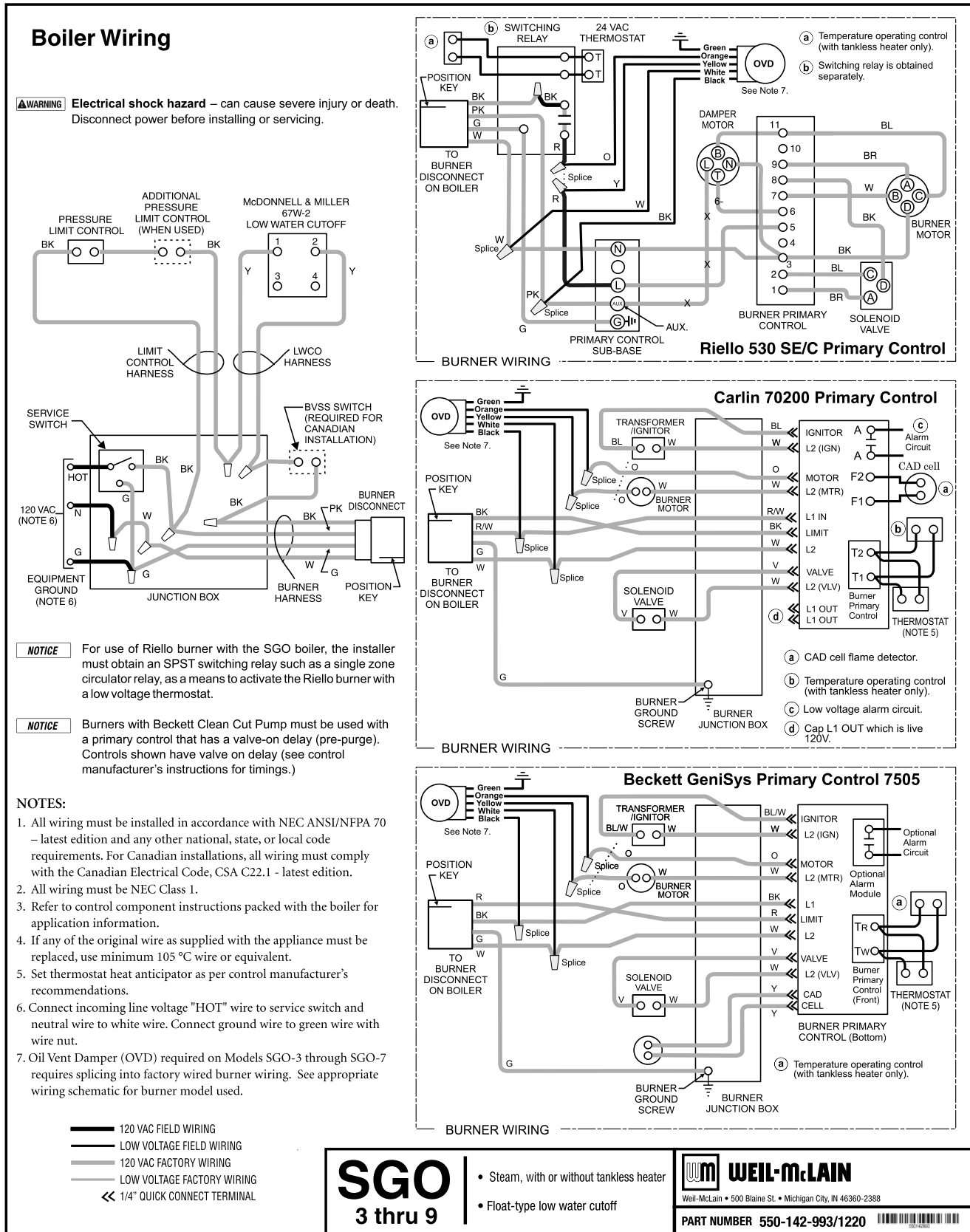

SGO

3 thru 9

- Steam, with or without tankless heater
- Float-type low water cutoff

WEIL-McLAIN
 Weil-McLain • 500 Blaine St. • Michigan City, IN 46360-2388
PART NUMBER 550-142-993/1220



WARNING SERVICE TECHNICIAN ONLY — read and follow completely.

Connect wiring (Float-type LWCO) (continued)

Figure 20 Boiler wiring for float-type LWCO — component locations for wiring diagram, Figure 19, page 28

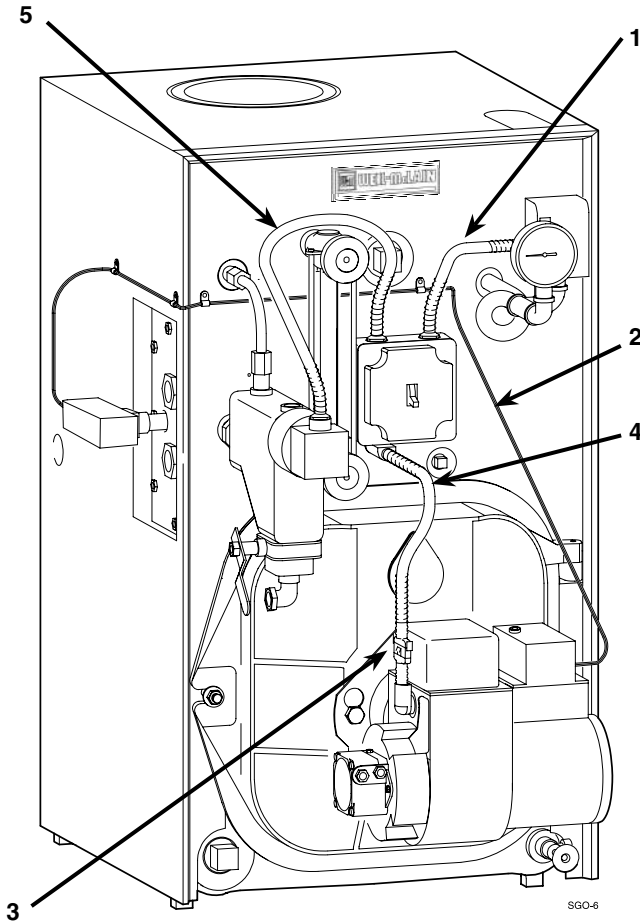

- 1 Pressure control wiring harness
- 2 Tankless heater control wiring
- 3 Burner disconnect plug
- 4 Burner wiring harness
- 5 Low water cutoff wiring harness (not furnished on Semi-packaged and Knocked-down boilers).

Blocked vent shutoff switch (BVSS), when required

NOTICE In Canada, a blocked vent shutoff switch kit must be installed (see parts list page 42). See Figure 18, page 27.

When using the OVD damper kit, the BVSS is required, and is integrated into the damper harness wiring.

When using the BVSS without the OVD damper, the BVSS is wired directly to the junction box as follows.

The BVSS wiring diagram in Figure 21 shows boiler wiring only up to the burner disconnect. For additional information, refer to manufacturer's instructions.

1. Locate and remove boiler junction box cover.
2. Locate wire nut with yellow and black wire (if more than one exists, pick the one with black wire going to burner harness). Clip the wire nut.
3. Strip 1/2" from the ends of both the black and the yellow wires.
4. Clip the quick connects from the blue wires coming from the BVSS Harness and strip 1/2" from the ends.
5. Using two wire nuts from the kit, wire the blue wires in series with the black and yellow wires (see Figure 21).
6. Replace junction box cover.
7. Turn on power and verify safe operation of the appliance per GO Boiler Manual.
8. Restore boiler to normal operation.

Figure 21 BVSS wiring diagram (float-type LWCO)

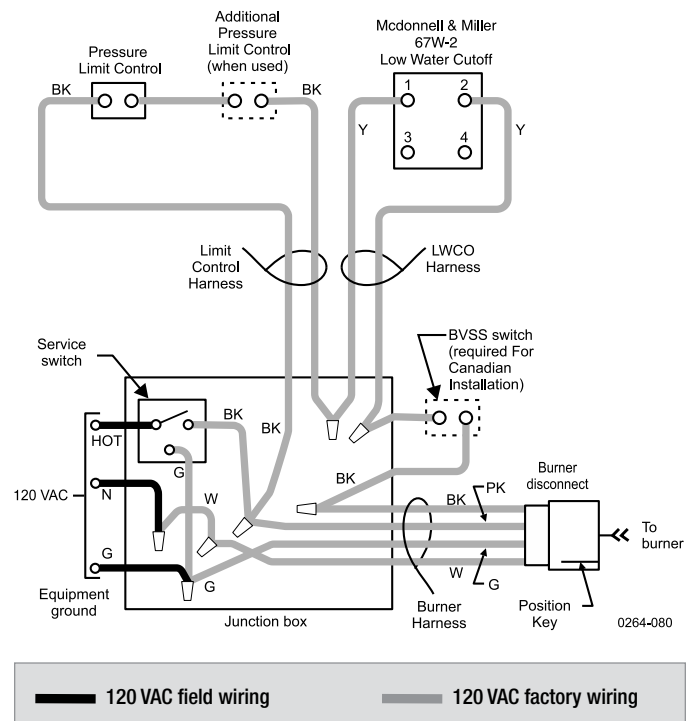



WARNING SERVICE TECHNICIAN ONLY — read and follow completely.

Connect wiring (Probe-type LWCO)

Figure 22 Boiler wiring for probe-type LWCO — see Figure 23, page 31 for component locations

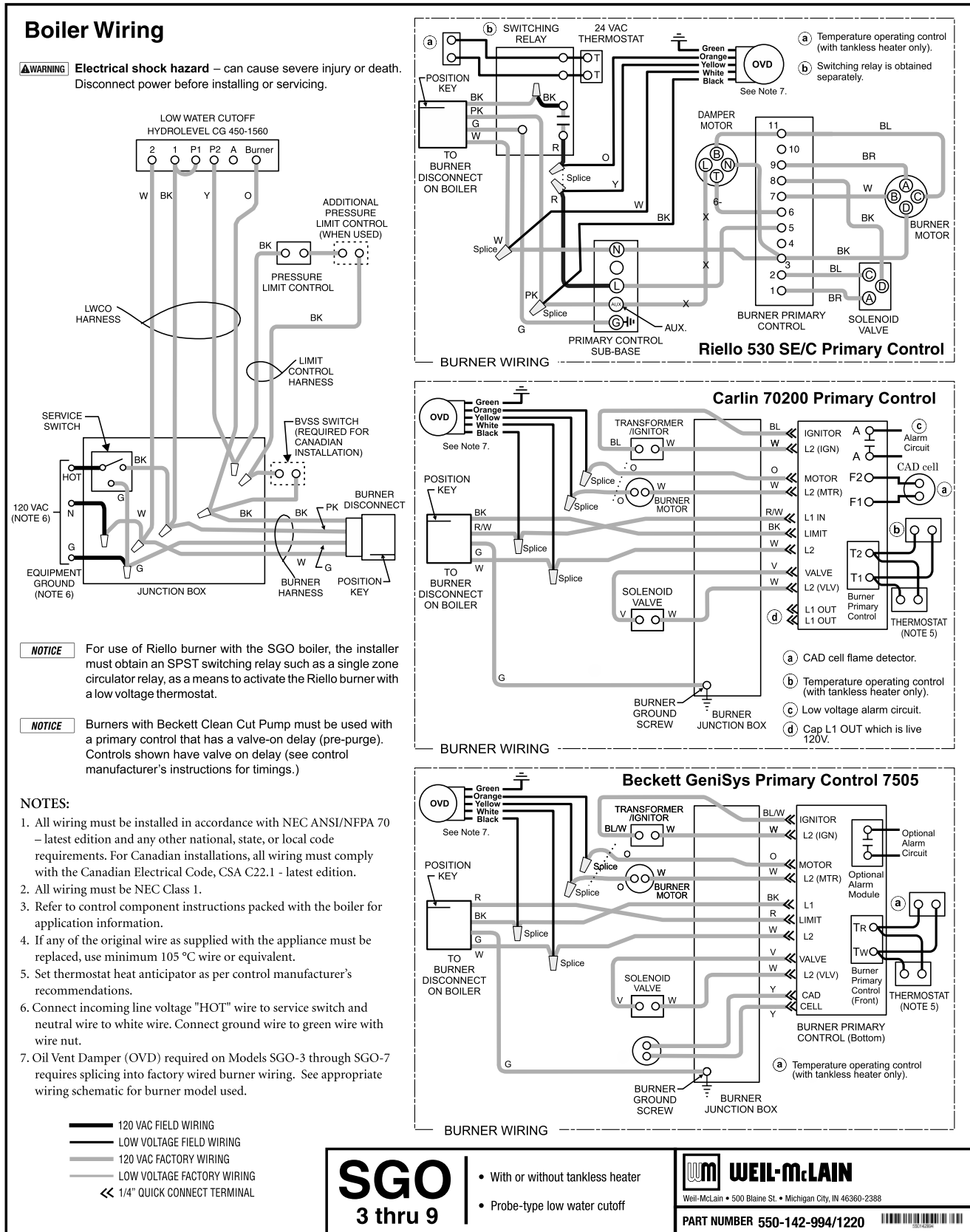

SGO

3 thru 9

- With or without tankless heater
- Probe-type low water cutoff

WEIL-McLAIN
 Weil-McLain • 500 Blaine St. • Michigan City, IN 46360-2388
PART NUMBER 550-142-994/1220



WARNING SERVICE TECHNICIAN ONLY — read and follow completely.

Connect wiring (Probe-type LWCO) (continued)

Figure 23 Boiler wiring for probe-type LWCO — component locations for wiring diagram, Figure 22, page 30

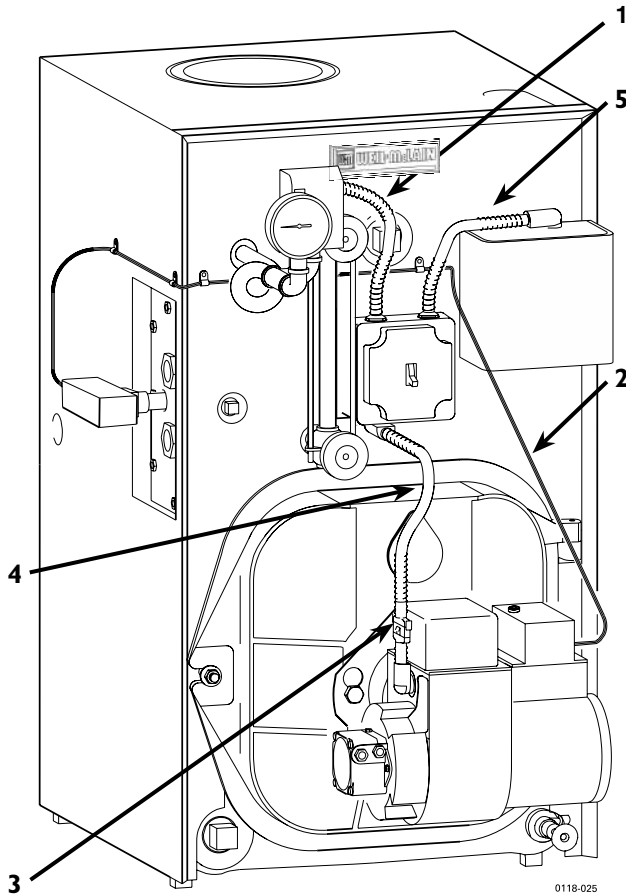

- 1 Pressure control wiring harness
- 2 Tankless heater control wiring
- 3 Burner disconnect plug
- 4 Burner wiring harness
- 5 Low water cutoff wiring harness (not furnished on Semi-packaged and Knocked-down boilers).

Blocked vent shutoff switch (BVSS), when required

NOTICE In Canada, a blocked vent shutoff switch kit must be installed (see parts list page 42). See Figure 18, page 27. When using the OVD damper kit, the BVSS is required, and is integrated into the damper harness wiring.

When using the BVSS without the OVD damper, the BVSS is wired directly to the junction box as follows.

The BVSS wiring diagram in Figure 24 shows boiler wiring only up to the burner disconnect. For additional information, refer to manufacturer’s instructions.

1. Locate and remove boiler junction box cover.
2. Locate wire nut with two black wires (if more than one exists, pick the one with black wire going to the burner harness). Clip the wire nut.
3. Strip 1/2" from the end of both the black wires.
4. Clip the quick connects from the blue wires coming from the BVSS Harness and strip 1/2" from the ends.
5. Using two wire nuts from the kit, connect the blue wires in series with the two black wires (see Figure 24).
6. Replace junction box cover.
7. Turn on power and verify safe operation of the appliance.
8. Restore boiler to normal operation.

Figure 24 BVSS wiring diagram (probe-type LWCO)

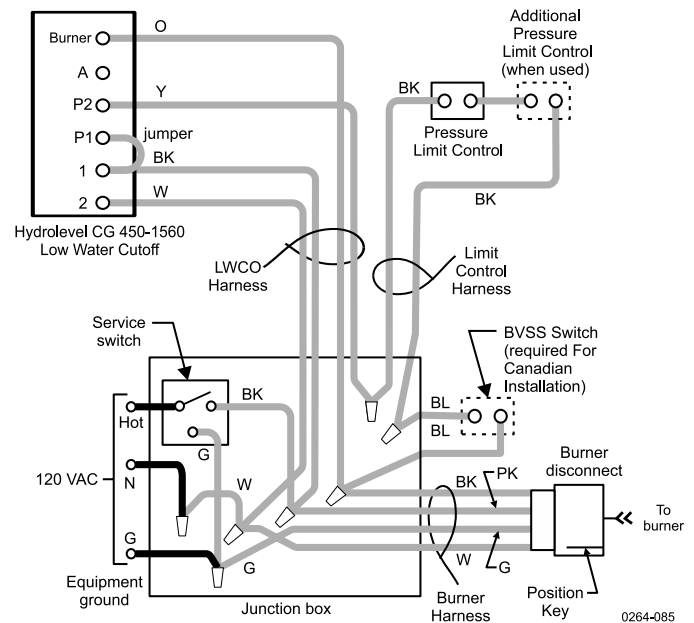

— 120 VAC field wiring — 120 VAC factory wiring



▲WARNING SERVICE TECHNICIAN ONLY — read and follow completely.

OVD-Vent damper wiring

Vent damper wiring

1. Boiler models SGO-3 through SGO-7 require the installation of the Field Controls OVD-7 damper, Weil-McLain part number 381-800-515. The damper is included with Packaged SGO-3 to SGO-6 boilers, and is sold separately for Semi-packaged and Knocked-down boilers.
2. When installing the boiler, wire all controls from vent damper and thermal switch in accordance with the OVD damper instruction sheet, which is provided with the damper.
3. Connect damper wires to the burner by splicing the burner wires as shown in the appropriate wiring diagram. See Figure 19, page 28 or Figure 22, page 30.

Connect oil piping

General oil piping requirements

Location and installation of oil tanks, oil piping and burners must follow:

- NFPA 31 - latest edition, Standard for the Installation of Oil-Burning Equipment.
- In Canada, CSA B139, Installation of Oil-Burning Equipment.
- Local codes and regulations.
- Information provided with burner and fuel pump.
- If any part of fuel oil tank is above level of burner, installation of an anti-siphon device is highly recommended to prevent flow of oil in case of oil line break.
- Support oil lines as required by codes.
- Make tank connections with swing joints or copper tubing to prevent breaking in case the tank settles. Make swing joints so they will tighten as tank settles. Non-hardening pipe joint compounds should be used on all threads.

▲WARNING Do not use Teflon tape as an oil pipe sealant. It can cause valves to fail, creating hazards. Do not use compression fittings, only flare fittings.

- Underground pipe must be run in a casing to prevent oil leaking into ground or under floor. Check local codes for information.

Oil piping connection at burner

See Figure 25 for recommended connection at burner, allowing burner mounting door to swing open completely for servicing.

Figure 25 Recommended oil piping connection to burner

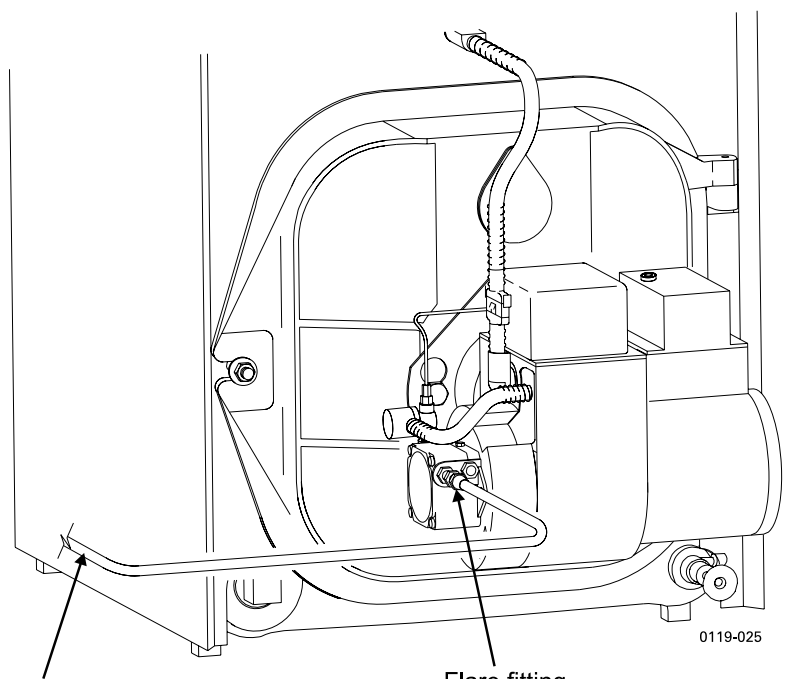

See local codes for appropriate arrangement and piping of filter, control valves, etc., back to oil tank.

Start up – Steam Boiler Water Treatment

Steam Heating Installation Considerations

Closed steam heating systems should not have high amounts of make-up water. Make-up water only occurs when the system is leaking or when make-up water is incorrectly administered. And, even with chemical treatment, make-up water will reduce boiler life due to corrosion. And chemical treatment may be difficult to execute if the system make-up volume is unpredictable.

Troubleshoot the system **BEFORE** considering water treatment. If the system is using make-up water, then the following may be likely:

- Leaking return lines, underground pipes, faulty steam traps, faulty air vents
- Automatic water feed is installed incorrectly or incorrectly adjusted
- If the system utilizes a condensate receiver, the feeder may be flooding due to long system time lag.

If the piping is NOT leaking, consider installing a boiler feed system (NOT a condensate return system). The boiler feed system provides condensate storage and allows the boiler to directly control water level. This is not the case with gravity return systems or condensate return systems — these only provide water to the boiler when the condensate returns from the system. If the system time lag is longer than boiler can provide steam, and the boiler is equipped with an automatic feeder, water will feed to the boiler before the condensate can return from the system. This will cause overflow and flooding when the condensate does return. Also, pumping cold make-up water directly into the boiler collapses the water level, causing false indications of need for make-up. With a boiler feed system, the float control on the boiler turns the feed pump on and off as needed. Make-up water is added at the boiler feed system tank. And the storage volume of the tank makes it unlikely that make-up will be needed UNLESS there is a system leak.

Chlorides

Over the last several decades, the level of chlorides in some ground water and city water supplies have increased due to use of salt during the removal of snow and ice from roads and highways, and the increased use of water softeners. Elevated levels of chlorides (over 200 ppm) in the water of steam boilers will accelerate water side corrosion and shorten the operating life of the boiler.

Chlorides and other dissolved solids are present in boiler make-up water and are not removed from the boiler when the boiler is producing steam. The level of chlorides and dissolved solids in the boiler water increase when make-up water is added to the boiler because of normal maintenance to low water cutoffs and system leaks. If there are high chloride and dissolved solid levels in boiler make-up water, boiler water treatment should be considered.

In general, cast iron steam boilers do not require water treatment for protection. However, some boiler water treatment chemicals can promote water level instability. Surging and priming in steam boilers can result even though the boiler was thoroughly cleaned before the treatment was added.

Systems where treatment should be considered are:

- Process applications
- Contaminated condensate
- Large make-up water requirements
- System components requiring corrosion inhibitor
- Extremely hard water
- Make-up water supply with higher than 30 ppm of chloride

Beware the Foam

Water treatment chemicals should be thoroughly reviewed before they are introduced into the boiler and heating system. Of particular concern are foaming agents that will interfere with the disengagement of the steam at the boiler waterline. For this reason, foaming agents cannot be tolerated in steam boilers.

Testing & Treatments

To test the boiler water treatment chemicals, prepare a small amount of the chemical intended for the boiler with water. In a ventilated area, put this mixture into a pan and bring to a “rolling boil” on the stove. If the mixture foams, it is not suitable for the boiler.

Recognized treatment compounds used for oxygen scavenging and corrosion protection should not affect the life of the elastomer sealing rings. Asking the treatment supplier to test a sealing ring in the proposed compound can eliminate any doubt. In any case, a compound containing petroleum should not be used.

Without Chemical Treatment

- When the chloride level is above 400 ppm, or the total dissolved solids (TDS) are above 1000 ppm, drain and refill the boiler with fresh water and bring the boiler to pressure for 15 minutes per the boiler manual to drive off excess oxygen.
- If chemical treatment is not used and chloride level and TDS levels are not monitored, drain and refill the boiler when the chloride level is above 400 ppm, or the total dissolved solids (TDS) are above 1000 ppm. After refilling the boiler, bring the boiler to pressure for 15 minutes per the boiler manual to drive off excess oxygen.

These steps will help prevent corrosion caused by high conductivity, but may not prevent under-deposit corrosion.

In general, cast iron steam boilers do not require water treatment for protection. However, some water conditions may require the boiler be drained and refilled, or in more aggressive areas, chemically treated.



▲WARNING SERVICE TECHNICIAN ONLY — read and follow completely.

Start up (continued)

Fill the system

1. Do not fill (except for leakage tests) until boiler is ready to be fired.
2. Fill to normal water line as indicated on jacket front panel.
3. Boiler water pH 7.0 to 8.5 is recommended.

NOTICE Failure to maintain recommended pH level can cause section failure and leaks.

4. Follow “Skim steam boiler” to assure proper operation.

Tips for steam systems

- Check boiler and system piping for leaks. Continual makeup water will reduce boiler life. Minerals can build up in sections, reducing heat transfer and causing cast iron to overheat, resulting in section failure.

▲CAUTION Failure to maintain recommended pH and repair leaks can cause section iron corrosion, leading to section failure and leaks. Do not use petroleum-based sealing or stop-leak compounds in boiler system. Damage to system components can result.

- For pH conditions outside 7.0 to 8.5 range or unusually hard water areas (above 7 grains hardness), consult local water treatment company.

Skim steam boiler

NOTICE Clean new steam boilers to remove any impurities. Failure to properly clean can result in violent water level fluctuations, water passing into steam mains, or high maintenance costs on strainers, traps or vents. Skim boiler only. Do not clean old piping or leaks can occur.

▲CAUTION Do not use petroleum-based compounds in boiler system. Damage to system components can result, causing property damage.

1. Provide 1½" skim piping from skim tapping to floor drain. Add a tee in piping to observe skim water level. Raise waterline to midpoint of skim tapping.
2. Fire burner to maintain water temperature below steaming temperature during skimming process.
3. Feed in water to maintain water level. Cycle burner to prevent rise in steam pressure. Continue skimming until discharge is clear.
4. While boiler is warm, but not hot, drain boiler through drain valve.

5. Remove skim piping. Close drain valve. Fill with fresh water to normal waterline. Start burner and steam for 15 minutes to remove dissolved gases. Stop burner.
6. Check traps and air vents for proper operation.
7. Process may need to be repeated after several weeks of operation.

To place in operation

▲DANGER Follow information below to prevent severe personal injury, death or substantial property damage:

- Do not use crankcase drainings or any oil containing gasoline. See burner manual for proper fuel oil.
- Do not attempt to start burner when excess oil has accumulated in combustion chamber, when unit is full of vapor, or when combustion chamber is very hot.
- Do not start burner unless collector hood, breeching and burner mounting door are secured in place. Never burn garbage or paper in the boiler.
- Never leave combustible material around boiler

1. Verify boiler is filled with water to normal waterline as indicated on jacket front panel.
2. Open burner door and verify rear target wall, floor and burner door insulations are in proper position and condition.
3. Verify burner mounting door is closed tightly and burner wiring harness is connected to junction box.
4. Factory burner adjustment and settings may not be suitable for specific job conditions. See “Burner adjustments” on page 37.

NOTICE A burner nozzle change may be required - refer to the burner instructions or boiler’s rating label for correct selection.

▲WARNING Make final burner adjustments using combustion test equipment to assure proper operation. Do not fire boiler without water. Sections will overheat, damaging boiler and resulting in substantial property damage.

5. Check boiler and system piping for leaks. See “Tips for steam systems.”
6. Inspect breeching and venting for proper operation.



WARNING SERVICE TECHNICIAN ONLY — read and follow completely.

Check out procedure

Check off Steps as completed

- Boiler properly filled with water?
- Boiler piping checked for leaks (including tankless heater, if used)?
- System vents operating properly?
- Boiler properly skimmed?
- Air purged from oil piping? Piping checked for leaks?
- Flue cap in place and tightened? Burner door closed, sealed and nut tight? Burner plugged in and service switch on?

WARNING Obtain gas-tight seal to prevent possible flue gas leakage and carbon monoxide emissions, leading to severe personal injury or death.

- Proper draft and burner flame? Final adjustment made with combustion test equipment?
- Test pressure control: While burner is operating, move indicator on limit control below actual boiler steam pressure. Burner should go off. Raise setting on pressure control above steam pressure and burner should re-ignite.
- Test low water cutoff(s): Follow control manufacturer’s instructions for testing procedures. Make sure burner goes off when control responds to low water condition. Burner should re-ignite when proper water level is restored.
- Test additional field-installed controls: If boiler has additional operating control or other controls, test for operation as outlined by control manufacturer. Burner should be operating and should go off when controls are tested. When controls are restored, burner should re-ignite.
- Limit control set to system pressure requirements?
- Thermostat heat anticipator setting (if available) set properly? Refer to “Connect wiring,” page 26.
- Boiler cycled with thermostat? Raise to highest setting and verify boiler goes through normal start-up cycle. Lower to lowest setting and verify boiler goes off.
- Observed several operating cycles for proper operation?
- Set room thermostat(s) to desired room temperature?
- Completed Installation and Service Certificate?
- Reviewed Maintenance and Service Manual with owner or maintenance person and instructed person to keep for future reference?
- Returned all instructions provided with boiler to its envelope and placed with boiler for future reference?

Installation and service certificate

Installation and service certificate

Date Installed: _____

Boiler Model Number: _____ Series: _____

Consumer Protection (CP) Number(s): _____

Measured Btu or GPH Input: _____

Installer: _____

(Company)

(Address)

(Phone)

- Installation instructions have been followed.
- Check-out procedure has been performed.
- Above information is certified to be correct.
- Information received and left with owner/ maintenance person.

(Installer’s Signature)



▲WARNING SERVICE TECHNICIAN ONLY — read and follow completely.

Annual service check list

Annual Service Call Checklist (follow in order listed below)		Dates										Comments	
1	Check that boiler area is free from combustible materials, gasoline and other flammable vapors and liquids.												
2	Check for and remove any obstruction to combustion and ventilation air flow to boiler.												
3	Check breeching and chimney or vent for obstructions, damage, etc. Repair or replace as necessary.												
4	Clean boiler flue ways. See page 38.												
5	Perform service on low water cutoff, relief valve and gauge glass. See page 37.												
6	Check boiler and piping for leaks and repair if found.												
7	Inspect and adjust burner. See burner manual and: <ul style="list-style-type: none"> • change nozzle. • check ignition electrode settings. • clean blower housing and wheel. • make sure blower wheel turns freely. • oil burner motor if required. • clean air inlet. • clean or change fuel filter and strainer. 												
8	Make sure boiler is filled with water. See page 34.												
9	Start unit and verify combustion settings with combustion test equipment. See page 34.												
10	Verify operation of all controls on boiler. See page 34.												

Any parts of the boiler furnished by Weil-McLain must be replaced by parts listed in Weil-McLain Boiler and Repair Parts Book.



Service and maintenance

General description of control operation

Low water cutoff

Shuts down boiler if there is a low water condition.

Steam relief valve

Provides discharge if boiler pressure exceeds 15 psig.

Pressure limit control

If high steam pressure occurs, control shuts down burners until pressure drops. Limit should be set higher than design pressure of system. Operating control can be set at 5 psig and adjusted to comfort level. Normal operation is usually less than 5 psig. At certain times the system may operate under vacuum conditions.

Gauge glass

Indicates boiler water level. Cold fill water level should correspond to line stamped on boiler jacket. When boiler operates, water level will fluctuate.

Pressure gauge

Provides reading of boiler pressure. Maximum boiler pressure is 15 psig.

Tankless water heater

Weil-McLain tankless heater ratings are based on 200°F boiler water temperature. To get rated output, set tankless heater control to 200°F. Control can be adjusted to meet system hot water requirements.

Burner adjustments

NOTICE A burner nozzle change may be required - refer to the burner instructions or boiler's rating label for correct selection.

▲WARNING Final burner adjustments must be made using combustion test equipment to assure proper operation. Do not fire boiler without water or sections will overheat.

1. Refer to burner manual for start-up.
2. Allow boiler to heat to design condition.
3. Burner should be adjusted to 13% CO₂ or less with a smoke level of zero and over-fire of $-0.01''$ to $-0.02''$. Re-adjust burner combustion to account for environmental conditions. Actual CO₂ value will vary and should be adjusted for clean and safe combustion operation. Seasonal variations as well as sufficient combustion air supply can affect proper combustion and boiler performance. The burner should only be adjusted by a service professional with appropriate instrumentation.

Controls requiring annual service

Float-type low water cutoff

Follow instructions to blow down cutoff on page 20. Also refer to instructions from cutoff manufacturer in envelope assembly provided with boiler.

Probe-type low water cutoff

Cutoff must be removed and inspected and cleaned annually. Refer to cutoff manufacturer's instructions in envelope assembly provided with boiler.

Steam relief valve

Check operation of steam relief valve. Follow instructions on label fastened to relief valve.

▲DANGER Scald potential. Do not check operation of relief valve unless discharge piping has been installed according to Boiler Manual. If piping is not in place, a qualified service technician must properly install piping.

Gauge Glass

To clean glass:

1. Close lower gauge glass cock and carefully open petcock below glass to blow water and sediment out of glass by steam pressure.
2. Slowly open lower gauge glass cock and allow a small amount of water to flush out through the open petcock.
3. Close petcock and fully open lower gauge cock. The water level should immediately rise to its proper level.
4. If gauge glass breaks, close off both gauge cocks and loosen glass retaining nuts to remove gauge glass. Do not use thin glass tubing as a replacement.



▲WARNING SERVICE TECHNICIAN ONLY — read and follow completely.

Service and maintenance

(continued)

Cleaning boiler flue ways

▲WARNING The boiler contains ceramic fiber and fiberglass materials. Use care when handling these materials per instructions on page 48 of this manual. This boiler contains ceramic fiber and fiberglass materials that have been identified as carcinogenic, or possibly carcinogenic, to humans). Failure to comply could result in severe personal injury.

▲DANGER Make sure all electrical connections to boiler are turned off and wait until boiler is warm, not hot, before cleaning. Failure to do so will result in severe personal injury, death or substantial property damage.

1. Top flue boilers -remove breeching and jacket top panel. Rear flue boilers - remove jacket top panel.
2. Remove flue collector hood, saving hardware for reassembly.
3. Shut off oil valves. Arrange drip pans under the areas of oil piping that will be disconnected. Disconnect oil line at burner so that you can swing open the door completely.
4. Line combustion chamber floor with newspaper to catch any soot that will be loosened in the cleaning process.
5. Starting at the top of the boiler, use a wire flue brush to thoroughly clean between all pins at all angles. Be careful not to damage side wall of rear refractory.
6. Move to the bottom of the flue ways and clean up between the sections to reach pins left uncleaned in Step #5.
7. Once the flue ways are cleaned, carefully remove the paper from the floor of the combustion chamber.
8. Verify sealing rope around flue area is intact. Visually check condition and position of insulation in combustion chamber floor, and the refractories at the rear of boiler and in the burner mounting door. Replace any parts as necessary.
9. Close burner mounting door and tighten nut securely. Place flue collector hood on top of boiler. Secure with hardware from Step #2.

▲WARNING Maintain a gas-tight seal to avoid possible flue gas leakage and carbon monoxide emissions, which can lead to severe personal injury or death.

10. Check breeching for sooting and clean if necessary. Install jacket top panel and breeching.
11. Reconnect oil line and all electrical connections.

Figure 26 Thoroughly clean flue ways between all pins at all angles. Start on top of boiler, finish from the bottom.

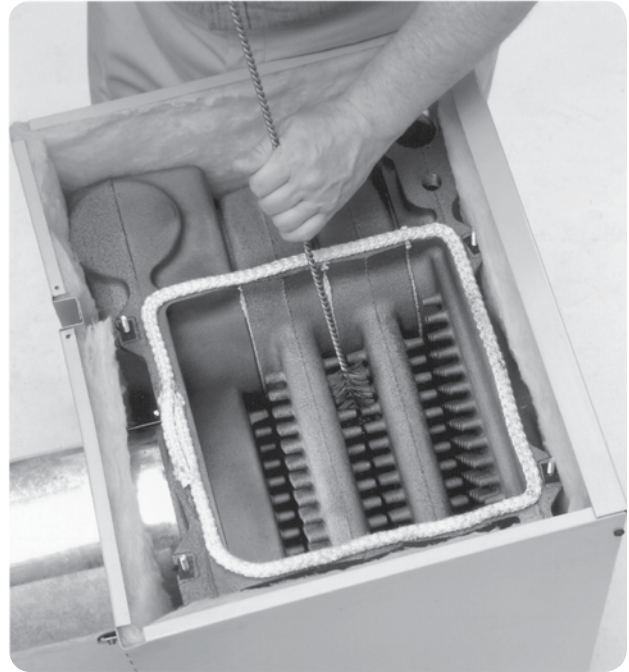

▲WARNING Wear a NIOSH -certified dust respirator (N95) while cleaning the boiler, per WARNING on page 48. Failure to comply could result in severe personal injury.

□ Inspect

Reported problems

Inspect any problems reported by owner and correct before proceeding.

Boiler area

1. Verify that boiler area is free of any combustible materials, gasoline and other flammable vapors and liquids.
2. Verify that boiler area is free of any of the contaminants listed in Table 2 on page 10 of this manual. If any of these are present in the boiler intake air vicinity, they must be removed. If they cannot be removed, install combustion air piping to the boiler in accordance with national, provincial or local codes.

Piping

1. Check the boiler interior piping and all system piping for signs of leaks.
2. Repair any leaks before proceeding.

▲DANGER Do not use petroleum-based cleaning or sealing compounds in boiler system. Severe damage to boiler will occur, resulting in substantial property damage.

▲WARNING Eliminate all system or boiler leaks. Continual fresh makeup water will reduce boiler life. Minerals can build up in sections, reducing heat transfer, overheating cast iron, and causing section failure. Leaking water may also cause severe property damage.



WARNING SERVICE TECHNICIAN ONLY — read and follow completely.

Service and maintenance (continued)

☐ Service.

Gauge glass

Normal waterline is halfway up gauge glass. Clean when needed.

1. Close lower gauge cock.
2. Open pet cock.
3. Open lower gauge cock and allow a small amount of water to flush out through open pet cock.
4. Close pet cock.
5. Open lower gauge cock.

⚠ DANGER Boiler pressure must be low to eliminate potential of severe burns.

⚠ WARNING If gauge glass breaks, close both gauge cocks. Replace gauge glass. Do not replace with thin glass tubing. Failure to comply could cause severe personal injury, death or substantial property damage.

☐ Check/test.

Boiler waterline

Normal waterline is halfway up gauge glass.

Limit controls

Inspect and test the boiler limit control. Verify operation by turning control set point below boiler pressure. Boiler should cycle off. Return dial to original setting.

Low water cutoffs

Probe-type low water cutoff (see below)

Clean and test probe-type low water cutoff for proper operation.

Remove, inspect and clean the low water cutoff at least annually before testing. Refer to low water cutoff manufacturer's instructions in envelope assembly provided with boiler.

1. Turn off power to boiler and wait 5 minutes.
2. Drain water to bottom of gauge glass.
3. Turn on power.
4. Set thermostat to call for heat. Red neon lamp on lower water cutoff should light.

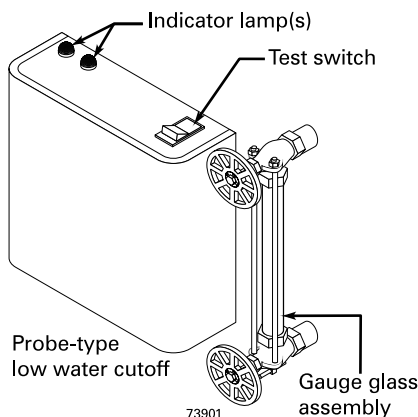

5. Wait 5 minutes. Boiler should not fire.
6. Refill boiler to correct waterline. Red lamp should go off.
7. Wait 5 minutes. Boiler should fire.
8. Return thermostat to normal setting.

☐ Check/test.

Float-type low water cutoff (when provided by others — see below)

Clean and test float-type low water cutoff (when provided by others) to clear float chamber of sediment.

1. Open blow down valve at bottom control.
2. Drain water into a bucket.

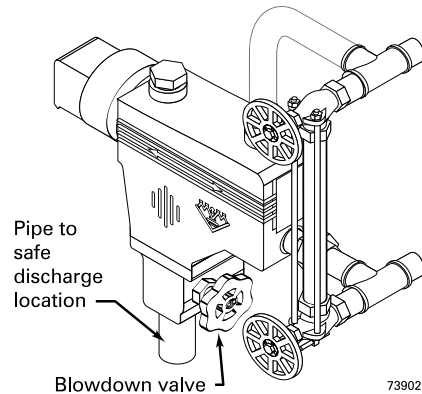

⚠ DANGER Scald potential. Boiler pressure must be low to avoid the potential of severe burns from steam.

3. Check float-type low water cutoff for proper operation:
 - a. Turn operating control to call for heat.
 - b. Before water gets hot, drain to bottom of gauge glass. Boiler should shut off after water level lowers a few inches.
 - c. Refill boiler to correct waterline. Boiler should come back on.

☐ Check monthly

Venting system

Visually inspect all parts of the flue gas venting system for any signs of blockage, leakage or joints or deterioration of the piping. Notify your qualified service technician at once if you find any problem.

⚠ WARNING Failure to inspect the vent system as noted above and have it repaired by a qualified service technician can result in vent system failure, causing severe personal injury or death.

**▲WARNING** SERVICE TECHNICIAN ONLY — read and follow completely.

Service and maintenance (continued)

Boiler and system piping

Visually inspect for leaks around piping, circulators, relief valve and other fittings. Check oil lines and boiler air for signs of oil leakage. Immediately call a qualified service technician to repair any leaks.

▲WARNING Have leaks fixed at once by a qualified service technician. Continual fresh makeup water will reduce boiler life. Minerals can build up in sections, reducing heat transfer, overheating cast iron, and causing section failure.

▲WARNING Do not use petroleum-based cleaning or sealing compounds in boiler system. Severe damage to boiler and system components can occur, resulting in possible severe personal injury, death or substantial property damage.

Review with owner

1. Review the Homeowner's Information, pages 2 through 7 with the owner.
2. Emphasize the need to perform the maintenance schedule specified on page 5.
3. Remind the homeowner of the need to call in a licensed contractor should the boiler or system exhibit any unusual behavior.
4. Remind the homeowner to follow the proper shut-down procedure and to schedule an annual start-up at the beginning of the next heating season.

Annual service

Boiler relief valve

After following the warning directions below, if the relief valve weeps or will not seat properly, replace the relief valve.

▲DANGER Before testing, make certain discharge pipe is properly connected to valve outlet and arranged to contain and safely dispose of boiler discharge. Wear gloves to protect your hands from hot surfaces. Verify that discharge piping is installed in accordance with this manual and the instructions on the relief valve tag. Failure to comply will expose operator and others to severe personal injury or death.

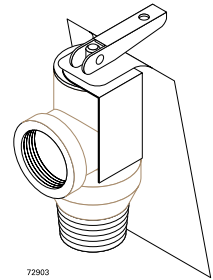

▲WARNING Safety relief valves should be reinspected **AT LEAST ONCE EVERY THREE YEARS**, by a licensed plumbing contractor or authorized inspection agency, to ensure that the product has not been affected by corrosive water conditions and to ensure that the valve and discharge line have not been altered or tampered with illegally. Certain naturally occurring conditions may corrode the valve or its components over time, rendering the valve inoperative. Such conditions are not detectable unless the valve and its components are physically removed and inspected. This inspection must only be conducted by a plumbing contractor or authorized inspection agency — not by the owner. Failure to reinspect the boiler relief valve as directed could result in unsafe pressure buildup, which can result in severe personal injury, death or substantial property damage.

▲WARNING Check the setting of the boiler limit control. The control should never be set with a pressure above 10 psig. Operating at a higher pressure can cause damage to the boiler relief valve.

▲WARNING The boiler relief valve must be tested at least monthly during the heating season to verify the valve and discharge piping flow freely.

Inspect the boiler relief valve and the relief valve discharge pipe for signs of weeping or leakage.

If the relief valve often weeps, the expansion tank may not be working properly.

- Immediately contact your qualified service technician to inspect the boiler and system.

If corrosion and/or deposits are noticed within the valve body, testing must be performed more often. A “try lever test” must also be performed at the end of any non-service period. Follow the instructions below for a “try lever test”:

- With the system at operating pressure, lift and hold the test lever fully open for at least 5 seconds to flush the valve seat free of sediment and debris. Then release lever and permit the valve to snap shut.



WARNING SERVICE TECHNICIAN ONLY — read and follow completely.

Replacement parts

Figure 27 SGO Series 4 boiler jacket

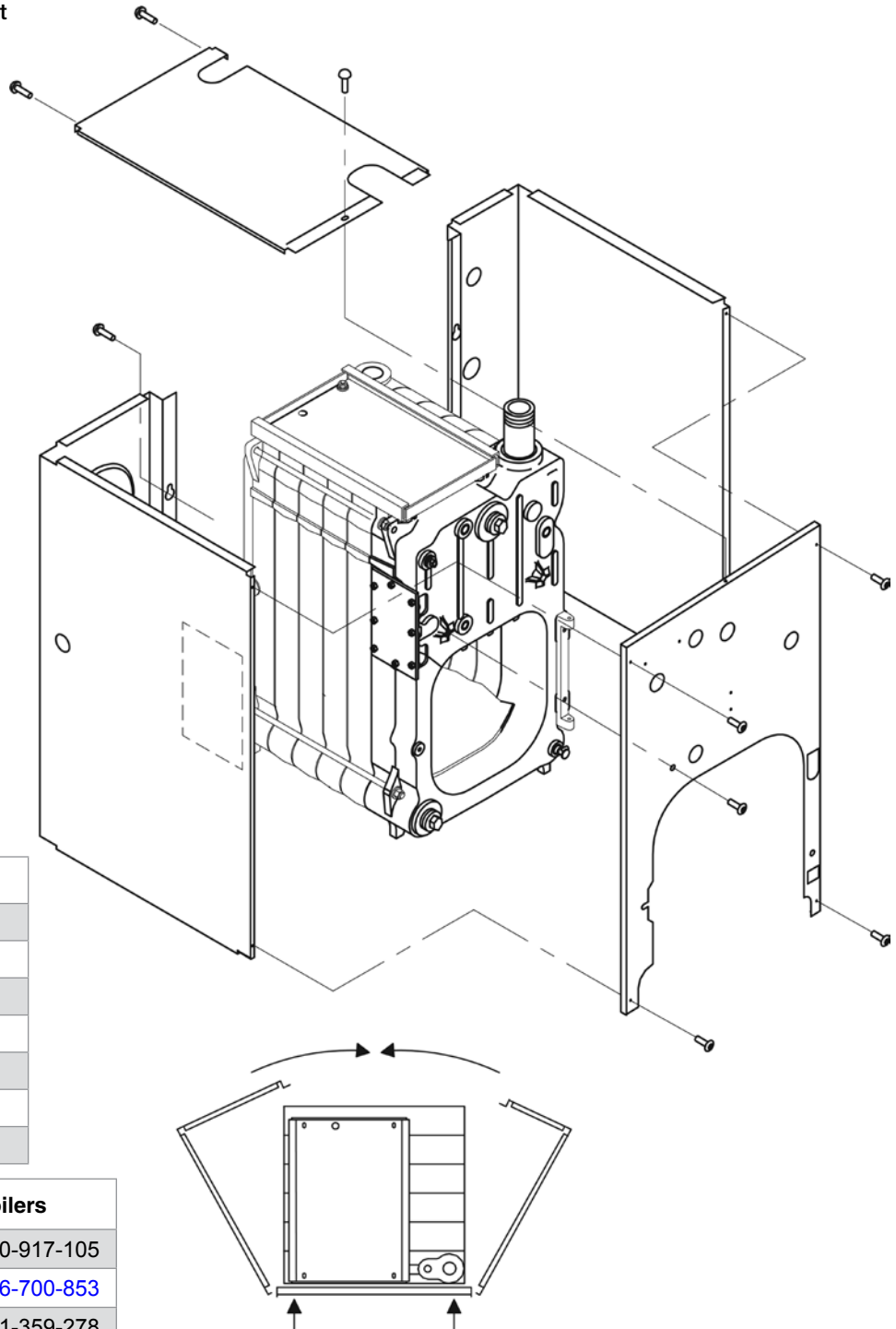

Complete Jacket cartons	
3 section	416-700-453
4 section	416-700-454
5 section	416-700-455
6 section	416-700-456
7 section	416-700-457
8 section	416-700-458
9 section	416-700-459

Common jacket parts for all boilers	
Plastic flue cap cover w/insulation	560-917-105
Jacket hardware kit	386-700-853
Touch up paint, Cloud spray can	381-359-278
Touch up paint, Slate spray can	384-000-141

Model	Jacket panel with insulation — front	Left side and rear	Right side and rear	Top panel with cap
SGO-3	381-355-928	381-355-929	381-355-974	381-355-933
SGO-4	381-355-928	381-355-930	381-355-975	381-355-934
SGO-5	381-355-928	381-355-931	381-355-976	381-355-935
SGO-6	381-355-928	381-355-932	381-355-977	381-355-936



▲WARNING SERVICE TECHNICIAN ONLY — read and follow completely.

Replacement parts

Figure 28 SGO Series 4 section and flue collector parts

Item	Description	Part Number	Item	Description	Part Number
A	Wide front section (7021)	316-700-245	G	Tie rod 1/2 x 51/2 (SGO-7, 8, 9)	560-234-464
B	Regular intermediate section (7015)	316-700-065	G	Tie rod 1/2 x 103/4 (SGO-7)	560-234-491
C	Intermediate section w/draw rod lugs (7016)	316-700-070	G	Tie rod 1/2 x 121/4 (SGO-3)	560-234-493
D	Back section w/7" flue, supply & 2" return (7027)	316-700-227	G	Tie rod 1/2 x 133/8 (SGO-7 & 8)	560-234-494
E	Section replacement kit (for 1 joint, includes seals, rope, adhesive and collector hood hardware) front or back section	386-700-852	G	Tie rod 1/2 x 14 (SGO-8, 9)	560-234-470
	Section replacement kit (for 2 joints, includes seals, rope and adhesive) intermediate section	386-700-851	G	Tie rod 1/2 x 15 (SGO-9)	560-234-495
	Section assembly, for SGO-3 w/jacket & collector hood installed	386-701-008	G	Tie rod 1/2 x 153/8 (SGO-4)	560-234-532
	Section assembly, for SGO-4 w/jacket & collector hood installed	386-701-009	G	Tie rod 1/2 x 161/2 (SGO-9)	560-234-496
	Section assembly, for SGO-5 w/jacket & collector hood installed	386-701-010	G	Tie rod 1/2 x 181/2 (SGO-5)	560-234-475
	Section assembly, for SGO-6 w/jacket & collector hood installed	386-701-011	G	Tie rod 1/2 x 215/8 (SGO-6)	560-234-536
	Section assembly only, for SGO-3	386-700-969	G	Tie rod 1/2 x 243/4 (SGO-7)	560-234-540
	Section assembly only, for SGO-4	386-700-970	G	Tie rod 1/2 x 28 (SGO-8)	560-234-544
	Section assembly only, for SGO-5	386-700-971	G	Tie rod 1/2 x 31 (SGO-9)	560-234-546
	Section assembly only, for SGO-6	386-700-972	H	Heater cover plate carton (cover plate, gasket, studs & nuts)	389-900-103
	Section assembly only, for SGO-7	386-700-669	J	Combustion chamber kit (rear & front ref., Door refractory blanket, rope, blanket & water glass)	386-700-355
	Section assembly only, for SGO-8	386-700-670	K	Burner mounting door assembly (door, obs. Port, rope, ins. And pins)	386-700-358
	Section assembly only, for SGO-9	386-700-671	L	Door hinge (7054)	330-054-300
F	Collector hood kit for SGO-3*	386-700-340	M	Door refractory	386-700-359
F	Collector hood kit for SGO-4*	386-700-341	N	Door refractory blanket	591-222-115
F	Collector hood kit for SGO-5*	386-700-342	P	Observation port shutter	460-039-867
F	Collector hood kit for SGO-6*	386-700-343	Q	Door seal rope 5'	590-735-104
F	Collector hood kit for SGO-7*	450-020-191	R	3/8" Glass rope for collector hood (7' for largest size hood)	590-735-109
F	Collector hood kit for SGO-8*	450-020-192	S	Flue cap assembly (cap, strap, rope and screws)	386-700-344
F	Collector hood kit for SGO-9*	450-020-193		Flue brush (123D)	591-706-214
				Blocked vent shutoff switch (Canada only)	511-624-650
			* Includes flue cap assembly, rope and hardware for installation.		



WARNING SERVICE TECHNICIAN ONLY — read and follow completely.

Replacement parts (continued)

Figure 29 SGO Series 4 section and flue collector parts

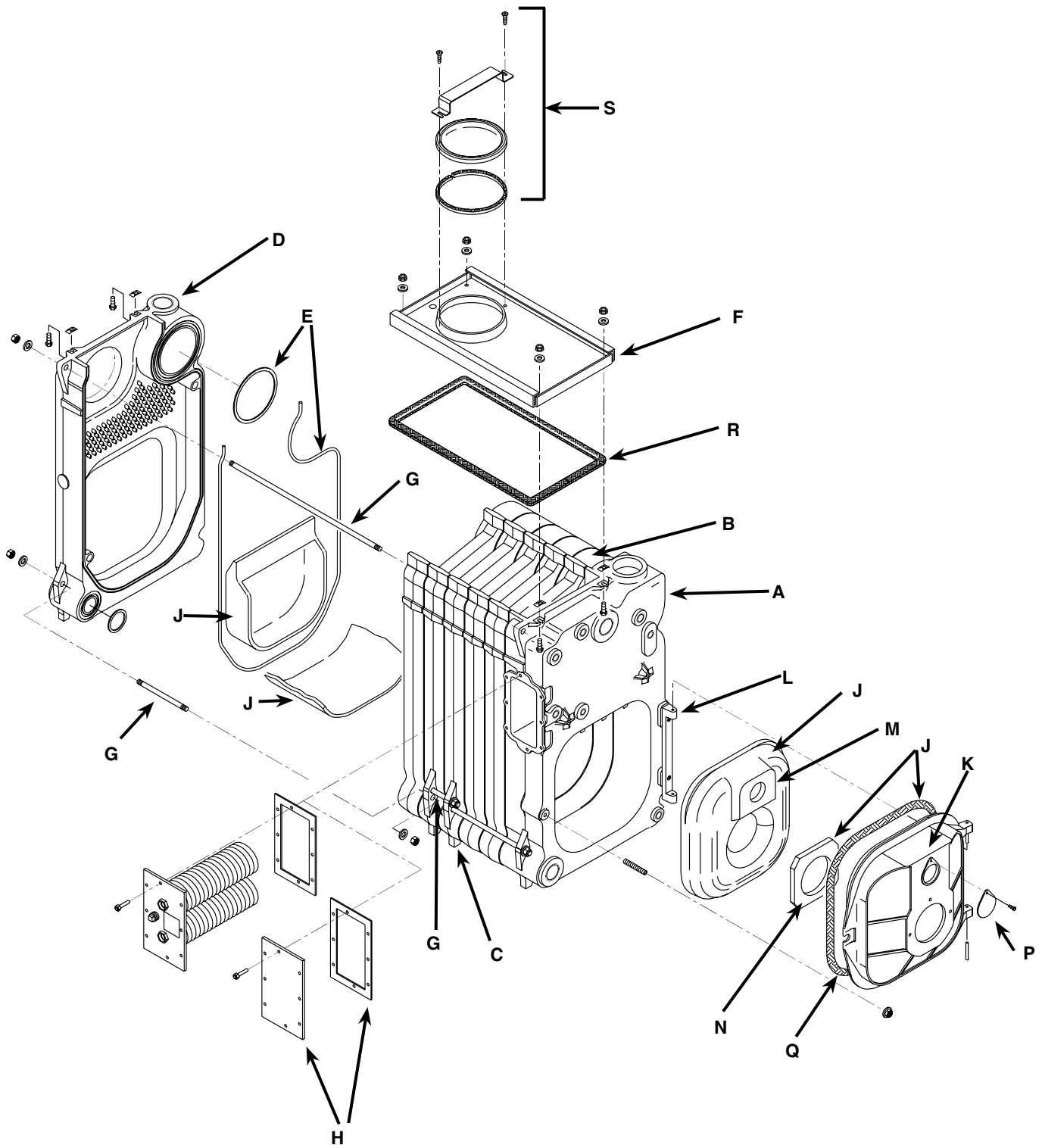

NOTICE

Repair parts must be purchased through Weil-McLain for the specific boiler as indicated in the list - page 42. Results from using modified or other manufactured parts will not be covered by warranty and may damage boiler or impair operation.



▲WARNING SERVICE TECHNICIAN ONLY — read and follow completely.

Replacement parts (continued)

Figure 30 SGO Series 4 Trim Parts

Item No.	Description	Part number
1	Syphon, 180° Bend, 1/4" brass pipe	560-640-698
2a	Steam relief valve, set to relieve at 15 PSIG., 3/4" NPT inlet 3/4" NPT side outlet, 300 lbs./hr steam capacity	511-548-023
2b	Steam relief valve, set to relieve at 15 PSIG., 3/4" NPT male inlet 3/4" NPT female side outlet, 407 lbs./hr steam capacity	
3	Steam pressure gauge, 0-30 PSIG.	510-218-045
4	Gauge cock set, B15, standard stem	510-218-135
5	Gauge glass kit, includes glass, gaskets and brass washers	383-600-001
6	Water gauge glass guard, 105/8" long	563-334-597
7	High pressure limit control, operating range 0.5-9 PSI., additive differential 1-5 PSI.	510-312-135
	High pressure limit control, operating range 0-15 PSI., differential 2-8 PSI.	
8	High temperature limit control, spst, automatic recycle with 3/4" well (used in tankless heater kit)	510-312-209
9	Low water cutoff, float type	511-114-495
10	Low water cutoff, probe type	511-100-007
11	Drain cock, 3/4", 11/2" shank	511-210-423
	Drain cock, 3/4"	511-246-392
12	Balanced draft damper (barometric) 7"	510-512-267
13	Junction box wiring harness assembly (Semi-packaged and Knocked-down boilers only)	591-391-848
14	Junction box cover assembly with service switch	591-391-854
15	Burner harness assembly	591-391-850
16	Limit control without well, spdt (for tankless heater)	510-311-024
17	Junction box-wiring harness assembly (SGO – float low water cutoff only - Packaged only)	591-391-842
18	Junction box-wiring harness assembly (SGO - probe low water cutoff only - Packaged only)	591-391-965
19	Flue pipe brackets (requires 2 of this item) (Not shown)	426-700-268
20	Tankless Heater - steam boiler, includes heater, gasket, nuts and studs. For SGO-3 through 9 (Not shown)	590-921-903
21	OVD-7 Vent damper kit – Required for SGO-3 through 7	381-800-515



WARNING SERVICE TECHNICIAN ONLY — read and follow completely.

Replacement parts (continued)

Figure 31 SGO Series 4 Trim Parts

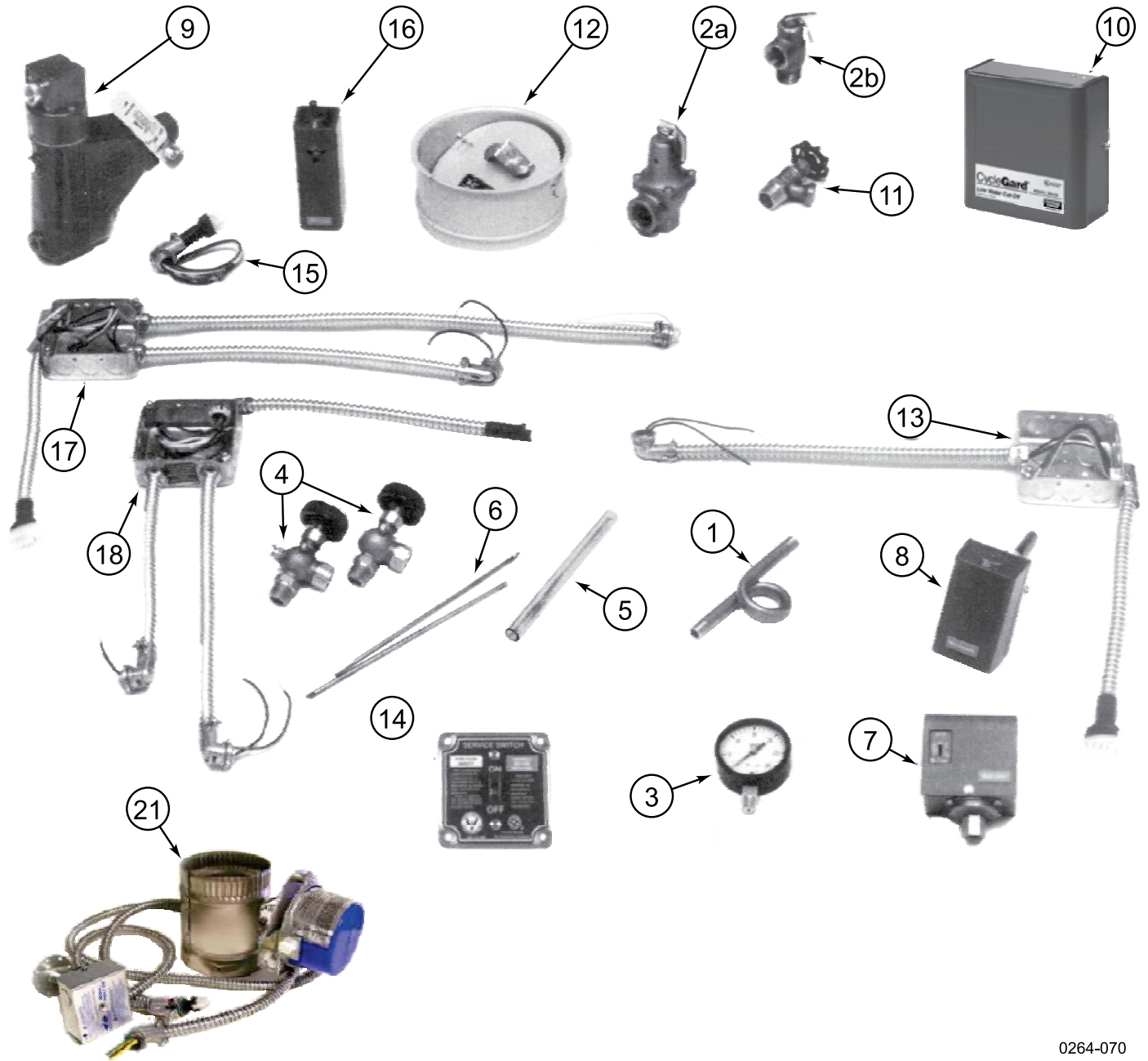

0264-070

NOTICE Repair parts must be purchased through Weil-McLain for the specific boiler as indicated in the list - page 42. Results from using modified or other manufactured parts will not be covered by warranty and may damage boiler or impair operation.



▲WARNING SERVICE TECHNICIAN ONLY — read and follow completely.

Dimensions

Figure 32 SGO boiler dimensions — inches (mm)

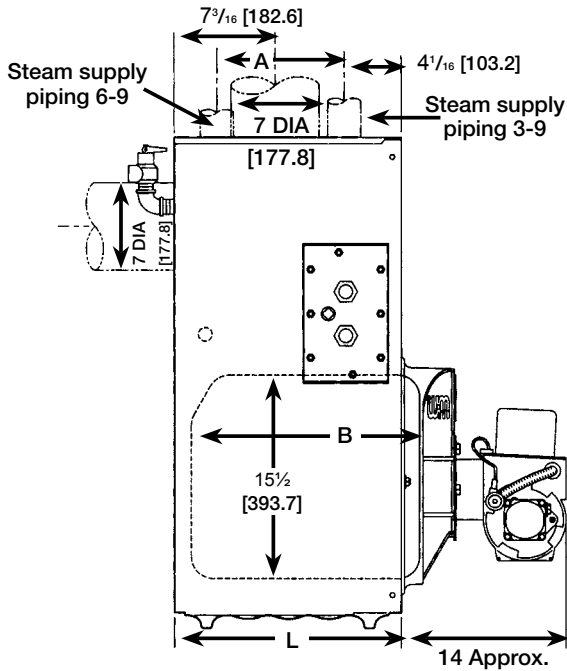

SGO side with burner

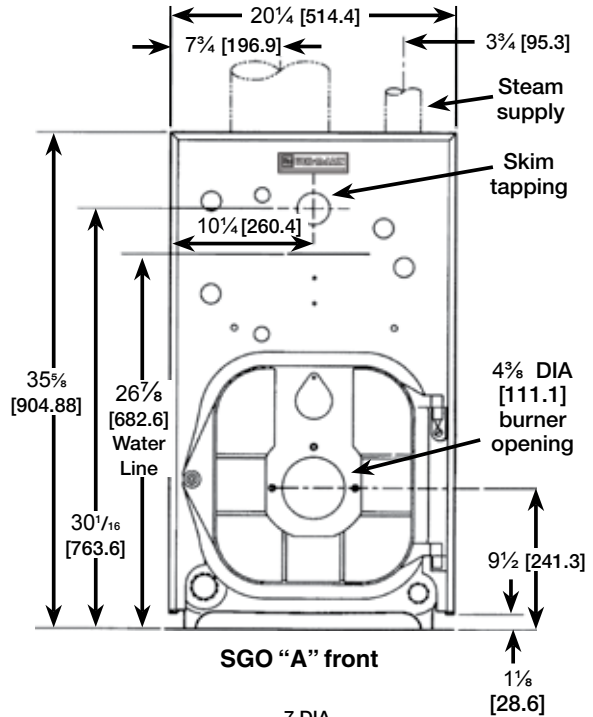

SGO "A" front

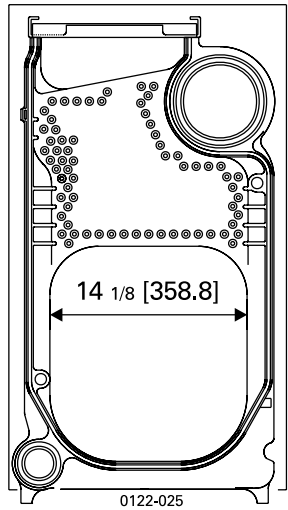

Intermediate

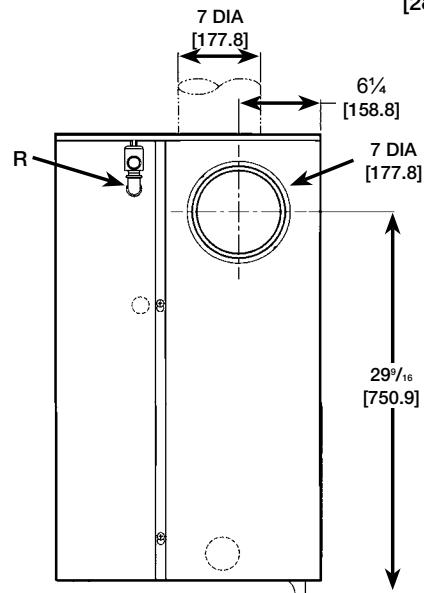

SGO back

Boiler model number	A		B		L	
	Inches	mm	Inches	mm	Inches	mm
SGO-3	—	—	13-1/2	342.9	16-7/8	428.7
SGO-4	—	—	16-5/8	422.1	20	508.0
SGO-5	—	—	19-7/8	504.9	22-1/8	587.2
SGO-6	19	482.6	23	584.2	26-1/4	666.7
SGO-7	22-1/8	561.8	26-1/8	663.4	29-3/8	746.2
SGO-8	25-1/4	641.4	29-1/4	742.9	32-1/2	825.5
SGO-9	28-3/8	720.9	32-3/8	822.4	35-5/8	904.7



WARNING SERVICE TECHNICIAN ONLY — read and follow completely.

Ratings

Figure 33 SGO steam boiler ratings



DOE

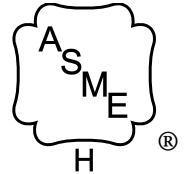

AHRI Certified Rating

Boiler Model Number	Burner Input		Heating Capacity	Seasonal Efficiency	Net Ratings Note 5		Steam Boiler Water Content	Minimum Chimney Dimensions			Flue Outlet Diameter	Draft Loss Thru Boiler	OVD Damper Required
	GPH Note 3	MBH Note 2	MBH Note 2	AFUE %	Steam Sq. Ft.	Steam MBH	Gallons Note 8	Rect. In.	Round In.	Height Ft.	Size Inches Note 1 & 7	Inch W.C. Note 9	Yes/No
SGO-3	0.95	133	114 (10)(11)	85.0	358	86	10.7	8 x 8	6	15	7	.020	Yes
SGO-4	1.20	168	144 (10)(11)	85.0	450	108	12.5	8 x 8	6	15	7	.010	Yes
SGO-5	1.45	203	174 (10)(11)	85.0	546	131	14.2	8 x 8	7	15	7	.015	Yes
SGO-6	1.75	245	210 (10)(11)	85.0	658	158	16	8 x 8	7	15	7	.015	Yes
SGO-7	2.00	280	240 (10)(11)	85.0	758	182	17.7	8 x 8	8	15	7	.015	Yes
SGO-8	2.30	322	266 (4)(6)	—	833	200	19.4	8 x 12	8	20	7	.025	---
SGO-9	2.55	357	295 (4)(6)	—	921	221	21.2	8 x 12	8	20	7	.030	---

NOTES:

1. SGO boiler designed with convertible vertical and horizontal flue outlet.
2. MBH refers to thousands of Btu per hour.
3. Based on 140,000 Btu/gal.
4. Based on standard test procedures prescribed by the United States Department of Energy at combustion condition of 13.5% CO₂ and -0.02" W.C. draft over fire.
5. Net ratings are based on net installed radiation of sufficient quantity for the requirements of the building and nothing need be added for normal piping and pick-up. Steam ratings are based on a piping and pick-up allowance of 1.33. An additional allowance should be made for unusual piping and pick-up loads. Consult local Weil-McLain Sales Office.
6. Gross output
7. See page 18 for minimum breeching diameter.
8. To water line.
9. Listed draft losses are for factory-shipped settings.
10. Based on standard test procedures prescribed by the United States Department of Energy at combustion of 13.0% CO₂ and -0.02" W.C. draft over fire.
11. Installation of OVD Automatic Vent Damper (P/N 381-800-515) is required.

Note: A burner nozzle change may be required - refer to the burner instructions or boiler's rating label for correct selection.



Handling ceramic fiber and fiberglass materials

REMOVAL OF COMBUSTION CHAMBER LINING OR BASE PANELS

▲WARNING The combustion chamber lining or base insulation panels in this product contain ceramic fiber materials that have been identified as carcinogenic, or possibly carcinogenic, to humans. Ceramic fibers can be converted to cristobalite in very high temperature applications. The International Agency for Research on Cancer (IARC) has concluded, “Crystalline silica inhaled in the form of quartz or cristobalite from occupational sources is carcinogenic to humans (Group 1).”:

Precautionary measures

- ❑ Avoid breathing fiberglass dust and contact with skin or eyes.
 - Use NIOSH certified dust respirator (N95). This type of respirator is based on the OSHA requirements for fiberglass wool at the time this document was written. Other types of respirators may be needed depending on the job site conditions. Current NIOSH recommendations can be found on the NIOSH web site at <http://www.cdc.gov/niosh/homepage.html>. NIOSH approved respirators, manufacturers, and phone numbers are also listed on this web site.
 - Wear long-sleeved, loose fitting clothing, gloves, and eye protection.
- ❑ Apply enough water to the combustion chamber lining or base insulation to prevent airborne dust.
- ❑ Remove combustion chamber lining or base insulation from the boiler and place it in a plastic bag for disposal.
- ❑ Wash potentially contaminated clothes separately from other clothing. Rinse clothes washer thoroughly.

NIOSH stated First Aid

- ❑ Eye: Irrigate immediately
- ❑ Breathing: Fresh air

REMOVAL OF FIBERGLASS WOOL or

INSTALLATION OF FIBERGLASS WOOL OR BASE PANELS:

▲WARNING This product contains fiberglass jacket insulation and ceramic fiber materials in combustion chamber lining or base panels in gas fired products. Airborne fibers from these materials have been listed by the State of California as a possible cause of cancer through inhalation.

Precautionary measures

- ❑ Avoid breathing fiberglass dust and contact with skin or eyes.
 - Use NIOSH certified dust respirator (N95). This type of respirator is based on the OSHA requirements for fiberglass wool at the time this document was written. Other types of respirators may be needed depending on the job site conditions. Current NIOSH recommendations can be found on the NIOSH web site at <http://www.cdc.gov/niosh/homepage.html>. NIOSH approved respirators, manufacturers, and phone numbers are also listed on this web site.
 - Wear long-sleeved, loose fitting clothing, gloves, and eye protection.
- ❑ Operations such as sawing, blowing, tear out, and spraying may generate airborne fiber concentration requiring additional protection.
- ❑ Wash potentially contaminated clothes separately from other clothing. Rinse clothes washer thoroughly.

NIOSH stated First Aid

- ❑ Eye: Irrigate immediately
- ❑ Breathing: Fresh air