



## Series 4 Gas-Fired Water Boilers

# Boiler Manual

- Installation
- Maintenance
- Startup
- Parts

*Now With Built In  
Low Water Cut Off Functionality*



*\*Blower cover on sizes CGi 25-6 only*



**DO NOT USE BOILER DURING CONSTRUCTION** unless you provide dust-free air to the boiler area or follow the requirements given on page 9. Failure to comply could result in severe personal injury, death or substantial property damage.



Installation and service of the boiler must be performed by a qualified installer or service technician. **Before installing**, read all instructions, including this manual, and any related supplements. Perform steps in the order given. Failure to comply can result in severe personal injury, death or substantial property damage.



## How it works . . .



### Control module

The control module responds to signals from the room thermostat, air pressure switch and boiler limit circuit to operate the boiler circulator, pilot burner, gas valve and inducer. When room thermostat calls for heat, the control module starts the system circulator and inducer.

The control module runs the inducer long enough to purge the boiler flue passages, then opens the pilot valve and activates pilot ignition spark.

The control module allows up to 15 seconds to establish pilot flame. If flame is not sensed within 15 seconds, the control module will turn off the gas valve, flash the Flame light, and then enter a 15-second postpurge. The control module will then start a new cycle. This will continue indefinitely until pilot flame is established or power is interrupted. Once pilot flame is proven, the control module opens the gas valve to allow main burner flame.

When the room thermostat is satisfied, the control module turns off the gas valve, operates the inducer for a 15-second postpurge and waits for the next heat call.

The control module indicator lights show normal sequence when the lights are on steady. When a problem occurs, the control module flashes combinations of lights to indicate the most likely reason for the problem (see page 49).



### Transformer

The control transformer reduces line voltage to 24 volts for the gas valve and limit circuit.



### Inducer

The inducer pulls flue gases through the boiler, causing air to be pulled in through the boiler air openings. The inducer pushes the flue gases through the vent pipe as well.



### Air pressure switch

The air pressure switch signals the control module, telling the control module whether the inducer is working correctly or the vent is blocked.



### Water temperature/LWCO sensor

The water temperature/LWCO sensor provides a signal to the control module to turn off the gas valve if the temperature in the boiler goes above its setting or if a low water condition is sensed. (The circulator will continue to run as long as there is a call for heat.)



### Boiler circulator

The boiler circulator circulates water through the external (system) piping. The circulator is shipped loose, and can be mounted on either the boiler supply or return piping. The factory-installed circulator wiring harness provides ample length for either location. **NOTE** — The control module provides a pump exercising routine. If the boiler is not operated for 30 days, the control module will power the circulator for 30 seconds, then turn off.

### Other boiler components:

- |                                  |   |                                    |
|----------------------------------|---|------------------------------------|
| <b>a</b> supply to system        | <b>f</b> pressure/temperature gauge               | <b>k</b> pilot burner and bracket  |
| <b>b</b> return from system      | <b>g</b> relief valve                             | <b>l</b> gas manifold              |
| <b>c</b> stainless steel burners | <b>h</b> air vent connection                      | <b>m</b> cast iron boiler sections |
| <b>d</b> flue outlet             | <b>i</b> flame rollout thermal fuse element (TFE) | <b>n</b> flue collector            |
| <b>e</b> gas valve               | <b>j</b> burner shield                            | <b>o</b> junction box              |





# Contents

<b>How it works . . . . .</b>	<b>2</b>
<b>Hazard definitions . . . . .</b>	<b>4</b>
<b>Please read before proceeding . . . . .</b>	<b>5</b>
<b>1 Prepare boiler location . . . . .</b>	<b>6-11</b>
<b>2 Prepare boiler . . . . .</b>	<b>12-13</b>
<b>3 Venting . . . . .</b>	<b>14-19</b>
<b>4 Water piping . . . . .</b>	<b>20-29</b>
<b>5 Gas piping . . . . .</b>	<b>30</b>
<b>6 Field wiring . . . . .</b>	<b>31</b>
<b>7 Start-up . . . . .</b>	<b>32-35</b>
<b>8 Check-out procedure — checklist . . . . .</b>	<b>36</b>
<b>9 Department of Energy Compliance . . . . .</b>	<b>37</b>
<b>9a Operation . . . . .</b>	<b>37-43</b>
<b>10 Service and maintenance . . . . .</b>	<b>44-48</b>
<b>11 Troubleshooting . . . . .</b>	<b>49-60</b>
<b>12 Replacement parts . . . . .</b>	<b>62-68</b>
<b>13 Dimensions and ratings . . . . .</b>	<b>69-70</b>
<b>Handling ceramic fiber and fiberglass materials... .</b>	<b>71</b>

## Hazard definitions

The following defined terms are used throughout this manual to bring attention to the presence of hazards of various risk levels or to important information concerning the life of the product.



Indicates presence of hazards that **will cause severe** personal injury, death or substantial property damage.



Indicates presence of hazards that **can cause severe** personal injury, death or substantial property damage.



Indicates presence of hazards that **will or can cause minor** personal injury or property damage.



Indicates special instructions on installation, operation or maintenance that are important but not related to personal injury or property damage.



# Please read before proceeding

## Installer

- ▲WARNING** **Read all instructions before installing.** Follow all instructions in proper order to prevent personal injury or death.
- Consider **pipng and installation** when determining boiler location.
  - Any **claims for damage or shortage in shipment** must be filed immediately against the transportation company by the consignee.

**▲WARNING** The boiler contains ceramic fiber and fiberglass materials. Use care when handling these materials per instructions on of this manual. Failure to comply could result in severe personal injury.

**NOTICE** When calling or writing about the boiler— Please have the boiler model number from the boiler rating label and the Consumer Protection (CP) number from the boiler jacket. You may list the CP number in the space provided on the **Installation and service certificate** found on page 36.

**▲WARNING** The installer must verify that at least one carbon monoxide alarm has been installed within a residential living space or home following the alarm manufacturer's instructions and applicable local codes before putting the appliance into operation. Failure to adhere can result in severe personal injury, death or substantial property damage.

## User

- **This manual is for use only by your qualified heating installer/service technician.**
- Please refer to the **User's Information Manual** for your reference.
- We recommend regular **service by a qualified service technician, at least annually.**

**▲WARNING** Failure to adhere to the guidelines on this page can result in severe personal injury, death or substantial property damage.

### When servicing boiler —

- To avoid electric shock, disconnect electrical supply before performing maintenance.
- To avoid severe burns, allow boiler to cool before performing maintenance.

### Boiler operation —

- Do not block flow of combustion or ventilation air to boiler.
- Should overheating occur or gas supply fail to shut off, do not turn off or disconnect electrical supply to circulator. Instead, shut off the gas supply at a location external to the appliance.
- Do not use this boiler if any part has been under water. Immediately call a qualified service technician to inspect the boiler and to replace any part of the control system and any gas control that has been under water.

### Boiler water —

- Do not use petroleum-based cleaning or sealing compounds in boiler system. Water seal deterioration will occur, causing leakage between sections. This can result in substantial property damage.
- Do not use "homemade cures" or "boiler patent medicines". Serious damage to boiler, personnel and/or property may result.
- Continual fresh makeup water will reduce boiler life. Mineral buildup in sections reduces heat transfer, overheats cast iron, and causes section failure. Addition of oxygen and other gases can cause internal corrosion. Leaks in boiler or piping must be repaired at once to prevent makeup water.
- Do not add cold water to hot boiler. Thermal shock can cause sections to crack.

### Glycol — potential fire hazard —

All glycol is flammable when exposed to high temperatures. If glycol is allowed to accumulate in or around the boiler or any other potential ignition source, a fire can

develop. In order to prevent potential severe personal injury, death or substantial property damage from fire and/or structural damage:

- Never store glycol of any kind near the boiler or any potential ignition source.
- Monitor and inspect the system and boiler regularly for leakage. Repair any leaks immediately to prevent possible accumulation of glycol.
- Never use automotive antifreeze or ethylene glycol in the system. Using these glycols can lead to hazardous leakage of glycol in the boiler system.

**Saltwater Damage** — The exposure of boiler components to saltwater can have both immediate and long-term effects. While the immediate effects of saltwater damage are similar to those of freshwater (shorting out of electrical components, washing out of critical lubricants, etc.), the salt and other contaminants left behind can lead to longer term issues after the water is gone due to the conductive and corrosive nature of the salt residue. Therefore, Weil-McLain equipment contaminated with saltwater or polluted water will no longer be covered under warranty and should be replaced.

**Electrical Damage** — If any **electrical component or wiring** came into contact with water, or was suspected to have come into contact with water, replace the boiler with a new Weil-McLain boiler.

### ▲CAUTION Frozen Water Damage Hazard

Residences or buildings that are unattended in severely cold weather, boiler system components failures, power outages, or other electrical system failures could result in frozen plumbing and water damage in a matter of hours. For your protection, take preventative actions such as having a security system installed that operates during power outages, senses low temperature, and initiates an effective action. Consult with your boiler contractor or a home security agency.

# 1a Prepare boiler location — codes & checklist

## Installations must follow these codes:

- Local, state, provincial, and national codes, laws, regulations and ordinances.
- National Fuel Gas Code, ANSI Z223.1/NFPA 54 – latest edition.
- Where required by the authority having jurisdiction, the installation must conform to the Standard for Controls and Safety Devices for Automatically Fired Boilers, ANSI/ASME CSD-1 — latest edition.
- National Electrical Code, ANSI /NFPA 70 – latest edition.
- For Canada only: Natural Gas and Propane Installation Code, CAN/CSA B149.1 or B149.2 Installation Code, CSA C22.1 Canadian Electrical Code Part 1 and any local codes.

**NOTICE**

The CGi boiler gas manifold and controls meet safe operating and other performance criteria when boiler underwent tests specified in ANSI Z21.13 – latest edition.

**NOTICE**

For the Commonwealth of Massachusetts, read and follow the special instructions located on page 15 of this manual.

## Before locating the boiler, check the following:

- Check for nearby connection to:
  - System water piping
  - Venting connections
  - Gas supply piping
  - Electrical power
- Check area around boiler. **Remove any combustible materials, gasoline and other flammable liquids, or other contaminants.**

**WARNING**

Failure to keep boiler area clear and free of **combustible materials, gasoline and other flammable liquids and vapors** can result in severe personal injury, death or substantial property damage.

- Boiler must be installed so that gas control system components are protected from dripping or spraying water or rain during operation or service.
- If new boiler will replace existing boiler, check for and correct system problems, such as:
  1. System leaks causing oxygen corrosion or section cracks from hard water deposits.
  2. Incorrectly-sized expansion tank.
  3. Lack of antifreeze in boiler water causing system and boiler to freeze and leak.



# 1b Prepare boiler location — clearances

## Recommended SERVICE clearances (Fig. 1a)

1. Provide clearances for cleaning and servicing the boiler and for access to controls and components. See Figure 1a for recommendations.
2. Provide at least screwdriver clearance to jacket front panel screws for removal of front panel for inspection and minor service. If unable to provide at least screwdriver clearance, install unions and shutoff valves in system so boiler can be moved for servicing.

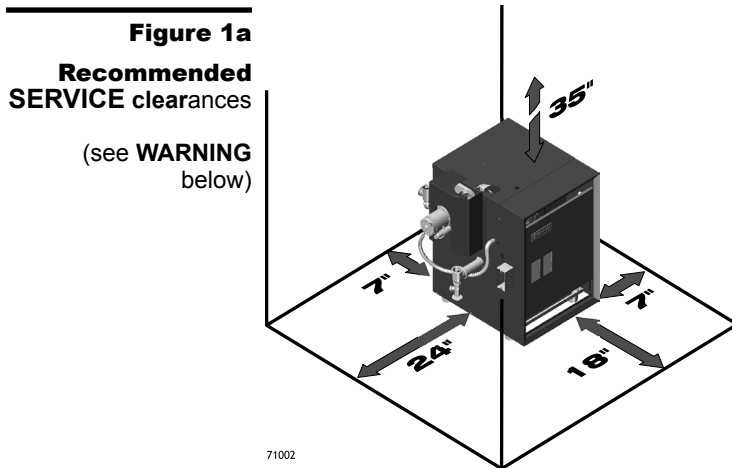

**WARNING** If any clearance is less than in Figure 1a, provide openings for combustion and ventilation air located on the wall or door opposite the boiler FRONT (see Figure 1b).

These openings must be located as shown in Figure 1b to provide proper air flow around the boiler. The free area of each opening (after deducting for louvers) must be at least **one square inch per 1,000 Btuh** of boiler input. If the building is of unusually tight construction (see page 11 for definition), the air openings must connect directly to outside or the building must have air openings to the outside as specified on page 11.

If clearances are equal to or greater than Figure 1a, see pages 10 and 11 for location and sizing of combustion air openings.

Failure to comply can result in severe personal injury, death or substantial property damage and reduced boiler life.

## Required MINIMUM clearances (Fig. 1b)

- WARNING** Never install the boiler in a space with clearances less than the minimum clearances shown in Figure 1b. Failure to comply can result in severe personal injury, death or substantial property damage and reduced boiler life.
1. **Hot water pipes:** at least  $\frac{1}{2}$  inch from combustible material.
  2. **Single-wall vent pipe:** at least 6 inches from combustible material.
  3. **Type B double-wall metal vent pipe:** refer to vent manufacturer's recommendation for clearances to combustible material.

Figure 1b Required MINIMUM clearances

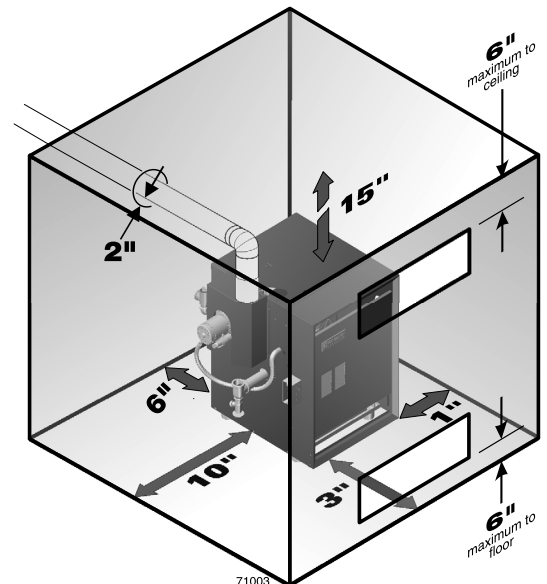

## Flooring

The CGi boiler is approved for installation on combustible flooring, but must never be installed on carpeting.

**WARNING** Do not install boiler on carpeting even if foundation is used. Fire can result, causing severe personal injury, death or substantial property damage.

## Foundation

1. Provide a solid brick or minimum 2-inch thick concrete foundation pad if any of the following is true:
  - floor can become flooded.
  - the boiler mounting area is not level.
2. Minimum dimensions are **25 inch length** by:

Minimum foundation width:			
CGi-25/3	12"	CGi-6	21"
CGi-4	15"	CGi-7	24"
CGi-5	18"	CGi-8	27"

## Residential garage installations

Take the following special precautions when installing the boiler in a residential garage. If the boiler is located in a residential garage, per ANSI Z223.1/NFPA 54 - latest edition:

- Mount the boiler a minimum of **18 inches above the floor** of the garage to assure the burner and ignition devices will be no less than 18 inches above the floor.
- Locate or **protect the boiler** so it cannot be damaged by a moving vehicle.



# 1c

## Prepare boiler location — vent system

**⚠ WARNING**

Failure to follow all instructions can result in flue gas spillage and carbon monoxide emissions, causing severe personal injury or death.

**⚠ DANGER**

Inspect existing chimney before installing boiler. Failure to clean or replace perforated pipe or tile lining will cause severe personal injury or death.

**⚠ DANGER**

**Direct exhaust venting (Category III) — DO NOT COMMON** vent the CGi in a direct exhaust system (Category III). Connecting more than one appliance to a direct exhaust system will cause flue gas spillage or appliance malfunction, resulting in possible severe personal injury, death or substantial property damage.

### When removing boiler from an existing common vent system:

At the time of removal of an existing boiler, the following steps shall be followed with each appliance remaining connected to the common venting system placed in operation, while the other appliances remaining connected to the common venting system are not in operation.

- a. **Seal any unused openings** in the common venting system.
- b. **Visually inspect the venting system** for proper size and horizontal pitch and determine there is no blockage or restriction, leakage, corrosion or other deficiencies which could cause an unsafe condition.
- c. **Test vent system** — Insofar as is practical, close all building doors and windows and all doors between the space in which the appliances remaining connected to the common venting system are located and other spaces of the building. Turn on clothes dryers and any appliance not connected to the common venting system. Turn on any exhaust fans, such as range hoods and bathroom exhausts, so they will operate at maximum speed. Do not operate a summer exhaust fan. Close fireplace dampers.
- d. **Place in operation** the appliance being inspected. Follow the operating instructions. Adjust thermostat so appliance will operate continuously.
- e. **Test for spillage** at draft hood relief opening after 5 minutes of main burner operation. Use the flame of a match or candle.
- f. After it has been determined that **each appliance** remaining connected to the common venting system properly vents when tested as outlined above, return doors, windows, exhaust fans, fireplace dampers, and any other gas-burning appliance to their previous conditions of use.

Any improper operation of common venting system should be corrected so the installation conforms with the National Fuel Gas Code, ANSI Z223.1/NFPA 54 – latest edition. Correct by resizing to approach the minimum size as determined using the appropriate tables in Part 13 of that code. Canadian installations must comply with B149.1 or B149.2 Natural Gas and Propane Installation Code.

### Chimney or vent requirements

1. Venting must be installed according to Part 7, Venting of Equipment, of National Fuel Gas Code, ANSI Z223.1/NFPA 54 – latest edition and applicable building codes. Canadian installations must comply with B149.1 or B149.2 Natural Gas and Propane Installation Code.
2. See Ratings table on page 66 for minimum chimney or vent sizes. A chimney or vent **without a listed cap** should extend **at least 3 feet above the highest point** where it passes through a roof of a building and **at least 2 feet higher than any portion of a building within a horizontal distance of 10 feet**. A chimney or vent must not extend less than the distances stated above.
3. A lined chimney is preferred and must be used when required by local, state, provincial and national codes, laws, regulations and ordinances. Vitreous tile linings with joints that prevent retention of moisture and linings made of noncorrosive materials are best. Advice for flue connections and chimney linings can be obtained from local gas utility. **Type B** double-wall metal vent pipe or single-wall vent pipe may be used as a liner.
4. Cold masonry chimneys, also known as outside chimneys, typically have one or more walls exposed to outside air. When any atmospheric gas-fired boiler with automatic vent damper is vented through this type of chimney, the potential exists for condensation to occur. Condensation can damage a masonry chimney. Weil-McLain recommends the following to prevent possible damage.
  - a. Line chimney with corrosion-resistant metal liner such as AL29-4C® single-wall stainless steel or B-vent. Size liner per National Fuel Gas Code ANSI Z223.1 /NFPA 54 – latest edition.
  - b. Provide drain trap to remove any condensate.



# 1d Prepare boiler location — air contamination

Please review the following information on potential combustion air contamination problems.

Refer to **Table 1** for products and areas which may cause contaminated combustion air.

**WARNING**

To prevent potential of severe personal injury or death, check for products or areas listed below before installing boiler. If any of these contaminants are found:

- remove contaminants permanently
- OR —
- isolate boiler and provide outside combustion air. See national, provincial or local codes for further information.

**Table 1** Corrosive or destructive contaminants and likely locations

Products to avoid	Areas likely to have contaminants
Spray cans containing chloro/fluorocarbons	Dry cleaning/laundry areas and establishments
Permanent wave solutions	Swimming pools
Chlorinated waxes/cleaners	Metal fabrication plants
Chlorine-based swimming pool chemicals	Beauty shops
Calcium chloride used for thawing	Refrigeration repair shops
Sodium chloride used for water softening	Photo processing plants
Refrigerant leaks	Auto body shops
Paint or varnish removers	Plastic manufacturing plants
Hydrochloric acid/muriatic acid	Furniture refinishing areas and establishments
Cements and glues	New building construction
Antistatic fabric softeners used in clothes dryers	Remodeling areas
Chlorine-type bleaches, detergents, and cleaning solvents found in household laundry rooms	Garages with workshops
Adhesives used to fasten building products and other similar products	Buildings under construction (where air is contaminated with particulates)
Airborne particulates (drywall dust, fiberglass particles, road or gravel dust, lint, etc.)	

**WARNING**

**CONSTRUCTION DUST HAZARD** — Airborne particulates, such as drywall dust or fiberglass dust, will cause blockage of the CGi burners, resulting in carbon monoxide production, a fire hazard, or building freeze damage. If the boiler is operated during construction, you must isolate the boiler to provide clean air for combustion. **If you are unable to ensure uncontaminated air in the boiler vicinity at all times, you must inspect the boiler at least once weekly.** When inspecting, clean the burners if necessary using the procedure given on page 45. Failure to follow these guidelines could result in severe personal injury, death or substantial property damage.

# 1e Prepare boiler location — air openings

## ⚠ WARNING

**Combustion air opening location and sizing requirements depend on the clearances around the boiler.** Check the boiler placement compared to Figure 1a, page 7.

**If all clearances are at least equal to Figure 1a, page 7,** apply the sizing and placement of openings given on pages 10 and 11.

**If ANY clearance is less than Figure 1a, page 7,** you must provide air openings sized and located as shown in Figure 1b, page 7. **DO NOT** apply the sizing and location information shown on page 10 or 11.

## Air openings must be provided

Combustion and ventilation air openings to be in accordance with the section “Air for Combustion and Ventilation,” of the National Fuel Gas Code, ANSI Z223.1/NFPA 54 – latest edition, or applicable provisions of the local building codes.

## ⚠ WARNING

Provide adequate combustion and ventilation air to assure proper combustion and reduce the risk of severe personal injury, death or substantial property damage caused by flue gas spillage and carbon monoxide emissions.

## Air opening options

### Two openings — Air supply from inside the building

1. If the building is of **unusually tight construction** (see definition, next page), the **building must also be provided with air openings directly to the outside**, sized and located per Figure 3, Figure 4 or Figure 5.
2. Buildings of typical construction should provide adequate combustion air from natural infiltration, so additional air openings to the building are not required.
3. See Figure 2. Provide **two openings** through the interior wall, within 12 inches of the ceiling and the floor, sized per Figure 2.

### Two openings — Air supply directly from outside

1. Air openings must be directly through an outside wall, or into a space that connects directly to the outside (such as a ventilated attic or crawl space, for example).
2. See Figure 3 — **Openings directly through an outside wall** — provide **two openings** within 12 inches of the ceiling and the floor, sized per Figure 3.
3. See Figure 4 — **Air supplied through vertical ducts** — provide **two openings** terminated within 12 inches of the ceiling and the floor, sized per Figure 4.
4. See Figure 5 — **Air supplied through horizontal ducts** — provide **two openings** within 12 inches of the floor and the ceiling, sized per Figure 5.

**Figure 2** Air openings to interior spaces

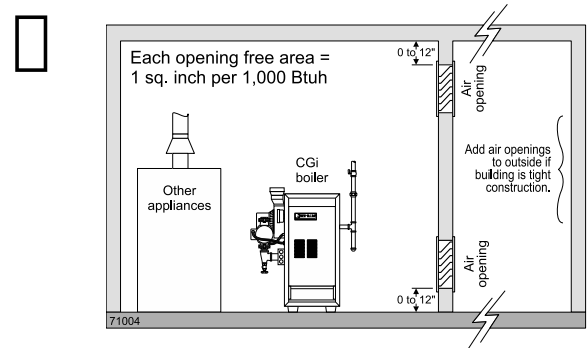

**Figure 3** Air directly through outside wall

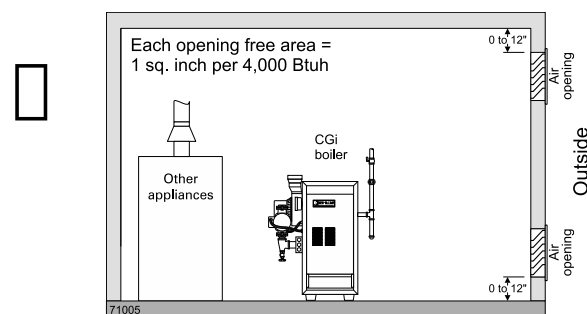

**Figure 4** Air from outdoors — vertical ducts

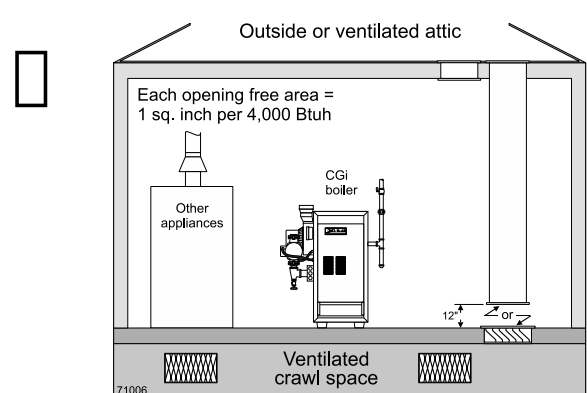

**Figure 5** Air from outdoors — horizontal ducts

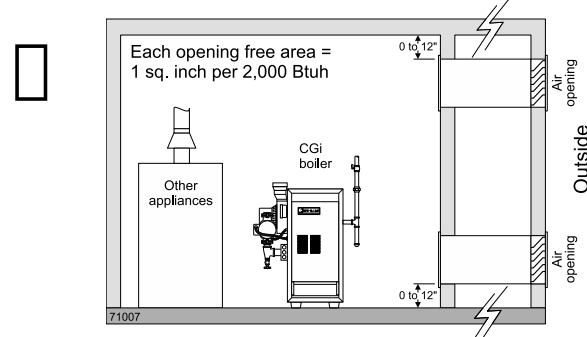

# 1e Prepare boiler location — air openings

## NOTICE

**FREE AREA** of openings — the minimum areas given in this manual are free area (equals the area, length times width of opening, after deduction for louver obstruction).

Use the free area information provided by the louver manufacturer. When this information is not available, assume:

- Wood louvers — assume free area is 20% of total; so the actual area of each opening with wood louvers would be 5 times the required free area.
- Metal louvers — assume free area is 60% of actual area; so, for wood louvers, the actual area of each opening must be 1.67 times the required free area.

## Single air opening option

A single combustion air opening can be used in lieu of the two-opening options on page 10, provided:

### Clearances from boiler to walls

- The boiler must have clearances of at least those shown in Figure 1a, page 7.

### Opening must be directly to outside

- The opening must connect directly to the outdoors or to a space that communicates directly to the outdoors (not to an interior space).
- The air can be provided through a direct opening or through a horizontal or vertical duct.

### Opening placement

- The top of the air opening must be within 12 inches of the ceiling.

### Opening size

- The free area of the opening must be at least equal to the sum of the areas of all equipment vent connectors in the space, and . . .
- The free area of the opening must be at least 1 square inch per 3,000 Btu/hr input rating of all equipment located in the space.

## Exception for large spaces

No combustion air openings are needed when the boiler (and other appliances) are installed in a space with a volume **at least 50 cubic feet per 1,000 Btu/h** of all installed appliances, provided:

- **the building must not have unusually tight construction** (see definition, this page).
- all clearances around the boiler must be no less than shown in Figure 1a, page 7.

To determine if the space is large enough to qualify:

- Add the total input of all appliances in MBH (1,000's of Btu/h).
- Multiply this number times 50 to determine minimum room volume.
- Example: For a total input of 100 MBH (100,000 Btu/h), minimum volume is  $50 \times 100 = 5,000$  cubic feet. At a ceiling height of 8 feet, the space must have at least  $5,000 \div 8 = 625$  square feet (25 feet x 25 feet, for instance).

## Unusually tight construction

Unusually tight construction means (per ANSI Z223.1/NFPA 54) buildings in which:

- Walls and ceilings exposed to the outside atmosphere have a continuous water vapor retarder with a rating of 1 perm or less with openings gasketed, and . . .
- Weather-stripping has been added on openable windows and doors, and . . .
- Caulking or sealants are applied to areas such as joints around windows and door frames, between sole plates and floors, between wall-ceiling joints, between wall panels, at penetrations for plumbing, electrical, and gas lines, and in other openings.

For such construction cases, if appliances use inside air for combustion, **provide air openings into the building from outside**. Size and locate these openings per the appropriate case in **Figure 3, 4 or 5** on page 10.

## Exhaust fans and air movers

The appliance space must never be under a negative pressure, even if the appliance(s) are installed as direct vent. Always provide air openings sized not only to the dimensions required for the firing rate of all appliances, but also to handle the air movement rate of the exhaust fans or air movers using air from the building or space.

## Motorized air dampers

If the air openings are fitted with motorized dampers, electrically interlock the damper to:

- Prevent the boiler from firing if the damper is not fully open.
- Shut the boiler down should the damper close during boiler operation.

To accomplish this interlock, wire an **isolated contact** (proving the damper open) in series with the thermostat input to the boiler. The boiler will not start if this contact is open, and will shut down should it open during operation.



# 2a Prepare boiler — placement & setup

## Place boiler/crate near position

1. Leave boiler in shipping carton and on pallet until installation site is ready.
2. Move entire shipping carton and pallet next to selected location.
3. Remove shipping carton.
4. Remove boiler from pallet.

**NOTICE** Do not drop boiler or bump jacket on floor or pallet. Damage to boiler can result.

- a. Tilt left side of boiler up and place a board under left legs.
- b. Tilt boiler the other way and place a board under right legs.
- c. Slide boiler backward off pallet and into position.
5. Check level.
  - a. Shim legs, if necessary.
  - b. Do not alter legs.

## Inspect orifices and burners

1. Remove front jacket door. Remove burner shield (see Figure 40, item 4, page 64).
2. Check for correctly-sized manifold orifices. See Table 2 for sizing. (The orifice size is stamped on the orifice spud barrel.)

**⚠ DANGER** Correctly-sized manifold orifices must be used. Failure to do so will result in severe personal injury, death or substantial property damage.

3. Reinstall burner shield.

**⚠ WARNING**

Do not operate boiler without burner shield in place. Failure to do so could result in severe personal injury, death or substantial property damage.

## Orifice replacement procedure

(when required)

1. Remove the screws securing the burner shield and remove burner shield.
2. Using a 7/16" open-end wrench, remove the burner orifices from the manifold.
3. Apply a small amount of pipe dope to each of the new orifices and install in the manifold using a 7/16" open-end wrench. Make sure the orifices are aligned correctly, not cross-threaded in the manifold tapings.

**⚠ WARNING**

Use only pipe dope compatible with propane gas, even if boiler is to be operated on natural gas. Failure to comply could result in severe personal injury, death or substantial property damage.

4. Carefully replace the burner shield.
5. Follow the check-out procedure, Section 8 page 36, to assure the boiler is now operating properly after orifices are replaced.

**Table 2** Manifold orifice sizing at sea level and altitudes to 4,500 feet

Location	Boiler model number	Natural gas		Propane gas	
		0-2,000 ft.	over 2,000 ft.	0-2,000 ft.	over 2,000 ft.
U. S.	CGi-25	2.30 mm	(Note 1)	#54	(Note 1)
	CGi-3 and CGi-5	2.55 mm		1.60 mm	
	CGi-4, CGi-6 - CGi-8	2.70 mm		1.65 mm	
Canada		<b>0-2,000 ft.</b>	<b>2,000-4,500</b>	<b>0-2,000 ft.</b>	<b>2,000-4,500</b>
	CGi-25	2.30 mm	#44	#54	#55
	CGi-3 and CGi-5	2.55 mm	#41	1.60 mm	1.45 mm
	CGi-4, CGi-6 - CGi-8	2.70 mm	#38	1.65 mm	#53

**Note 1:** For elevations above 2,000 feet, contact your local Weil-McLain sales office for details.



# 2b Prepare boiler — pressure test

## Hydrostatic pressure test

Pressure test boiler **before** attaching water or gas piping (except as noted below) or electrical supply.

### Prepare boiler for test

1. Remove the shipping nipple (from CGi supply tapping) and remove the boiler relief valve. **Temporarily** plug the relief valve tapping with a 3/4" NPT pipe plug.
2. Remove 1 1/4" nipple, reducing tee and drain valve from circulator hardware and pressure/temperature gauge carton. Install in boiler return connection as shown on page 3 and **Figure 42**, page 67. Install circulator on either the return or supply.
3. Remove 1 1/4" nipple, 1 1/4" x 1 1/4" x 1/2" tee and pressure/temperature gauge from circulator hardware and pressure/temperature gauge carton. Pipe to boiler supply connection as shown on page 3 and **Figure 42**, page 67. (Use pipe dope sparingly.)
4. Connect a hose to boiler drain valve, the other end connected to a fresh water supply. Make sure hose can also be used to drain boiler after test.
5. Connect a nipple and shutoff valve to system supply connection on the 1 1/4" tee. This valve will be used to bleed air during the fill. (Valve and nipple are not included with boiler.)
6. Connect a nipple and shutoff valve to system return connection (at circulator flange if circulator installed on return). This valve will be used to bleed air during the fill. (Valve and nipple are not included with boiler.)

### Fill and pressure test

1. Open the shutoff valves you installed on supply and return connections.
2. Slowly open boiler drain valve and fresh water supply to fill boiler with water.
3. When water flows from shutoff valves, close boiler drain valve.

4. Close shutoff valves.
5. Slowly reopen boiler drain valve until test pressure on the pressure/temperature gauge reaches no more than:

- 45 psig for boilers with 30 psig relief valve.
- 75 psig for boilers with 50 psig relief valve.

6. **Test for no more than 10 minutes at:**

- 45 psig for boilers with 30 psig relief valve.
- 75 psig for boilers with 50 psig relief valve.



**Do not leave boiler unattended.** A cold water fill could expand and cause excessive pressure, resulting in severe personal injury, death or substantial property damage.

7. Make sure constant gauge pressure has been maintained throughout test. Check for leaks. Repair if found.



**Leaks must be repaired at once.** Failure to do so can damage boiler, resulting in substantial property damage.



**Do not use petroleum-based cleaning or sealing compounds in boiler system.** Severe damage to boiler will occur, resulting in substantial property damage.

## Drain and remove fittings

1. Disconnect fill water hose from water source.
2. Drain boiler at drain valve or out hose, whichever provides best access to drain. Remove hose after draining if used to drain boiler.
3. Remove nipples and valves unless they will remain for use in the system piping.
4. Remove plug from relief valve tapping. See page 20 to replace relief valve.



# 3a Venting — general information

## CGi venting methods — Chimney draft or Direct exhaust

### Chimney draft venting

Chimney draft venting uses the natural draft provided by a vertical vent or chimney. Category I appliance (non-positive vent static pressure and vent gas temperature that avoids excessive condensate production in vent). See Section 3b. Chimney draft installations use:

1. Vent connector (single or double wall) sized to eliminate positive pressure in vent system. Diameter increases immediately at boiler.
2. Double wall metal vent (B-vent) or chimney with liner approved by the National Fuel Gas Code, ANSI Z223.1/NFPA 54 – latest edition, or in Canada B149.1 or B149.2 Natural Gas and Propane Installation Code.

### Direct exhaust — vertical or sidewall

Direct exhaust venting uses inside combustion air with no combustion air connector piping. All CGi flue gas vents are pressurized, requiring careful sealing of all joints. Category III appliance (positive vent static pressure and vent gas temperature that avoids excessive condensate production in vent). See pages 15-19.

Direct exhaust installations use:

1. Vent pipe specified in this manual.
2. Vent termination through outside wall, roof or unused chimney. Tight chimney areas will make vent joint construction very difficult.

# 3b Venting — chimney draft venting

**Table 3**  
Vent connector diameter

Boiler model number	“D” Minimum vent connector diameter
CGi-25 & CGi-3	4”
CGi-4 to CGi-6	5”
CGi-7 & -8	6”

**⚠ DANGER**

Inspect existing chimney before installing boiler. Failure to clean or replace perforated pipe or lining will cause severe personal injury or death.

**⚠ WARNING**

Vent sizing given in **Table 3** is only a general guideline. The vent connector and chimney must be designed, sized and constructed in compliance with all applicable codes. Failure to correctly size and install the vent system could result in severe personal injury, death or substantial property damage.

**Figure 7**  
Chimney draft venting

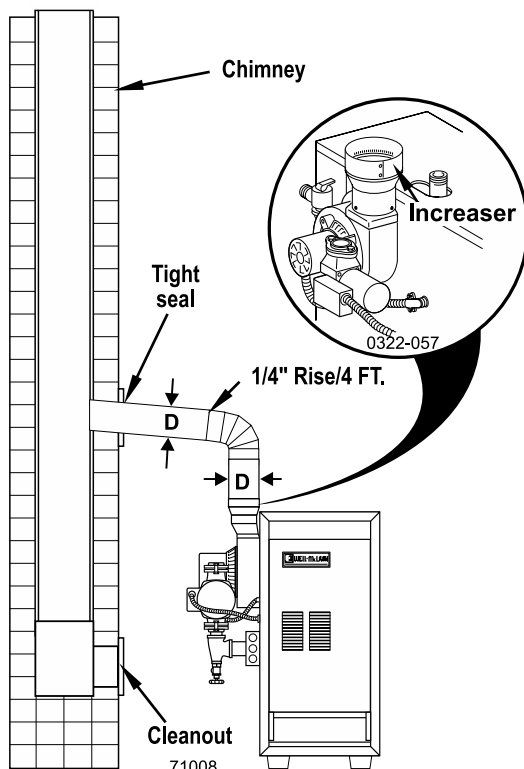

1. Use double wall metal vent (B-vent) or chimney with liner as required by the National Fuel Gas Code, ANSI Z223.1/NFPA 54 –latest edition, or in Canada, B149.1 or B149.2 Natural Gas and Propane Installation Code.
2. To prevent downdrafts, chimney should extend at least 3 feet above the highest point where it passes through a roof and at least 2 feet higher than any portion of a building within a horizontal distance of 10 feet.
3. To vent with another appliance, see National Fuel Gas Code, ANSI Z223.1/NFPA 54 –latest edition or in Canada B149.2 or B149.2 Natural Gas and Propane Installation Code.
4. Do not connect breeching to any portion of a mechanical draft system that can operate under positive pressure.
5. Maintain minimum 2” clearance from combustible materials to vent pipe.
6. Do not use chimney with an open fireplace.
7. Make horizontal runs as short as possible. Long runs can cause condensation.
8. When longer runs are used, support pipe with appropriate hangers.
9. To prevent blockage, do not vent into bottom of chimney.
10. Vent pipe must not go beyond inside wall of chimney.
11. Vent passing through floors or ceilings must be fire-stopped.
12. See **Figure 7** and **Table 3** to connect boiler to venting system.

# 3c Venting — Direct exhaust — components

## Obtain vent system components

- The following special gas vent systems comply with UL-1738 and ULC-S636 standards and are certified by CSA as the only systems suitable for use with CGi boilers (all 3" diameter):
  - Heat-Fab, Inc. **Saf-T Vent®**
  - Flex-L International, Inc. **StaR-34**
  - Z-Flex®, Inc. **Z-Vent II**
  - ProTech Systems **FasNSeal™**

### **WARNING**

Use only the vent starter of the same manufacturer as the vent components. Do not mix components from different systems. The vent system could fail, causing flue gas spillage, resulting in severe personal injury or death.

- Select vent method based on page 14 and installation requirements.
- Refer to **Table 4** for maximum vent run lengths and number of elbows. Do not exceed data in **Table 4**.
- Select vent components from separate **CGi, & GV Vent Component Supplement**. All components, including the vent

**Table 4** Maximum vent length

Max. vent length (feet)	Total number of elbows (Note 1)					
	1	2	3	4	5	6
CGi-25 to CGi-6	55	48	41	34	27	20
CGi-7	35	28	21	14	7	--
CGi-8	28	21	14	7	--	--
Note 1:	Do not include termination fitting when counting total number of elbow.					
* (Minimum length for all applications is 2 feet equivalent with two (2) elbows.						

starter, must be of the same vent manufacturer. Do not mix components.

## Massachusetts installations

- For all side wall horizontally vented gas fueled equipment installed in every dwelling, building or structure used in whole or in part for residential purposes, including those owned or operated by the Commonwealth and where the side wall exhaust vent termination is less than seven (7) feet above finished grade in the area of the venting, including but not limited to decks and porches, the following requirements shall be satisfied:
  - INSTALLATION OF CARBON MONOXIDE DETECTORS.** At the time of installation of the side wall horizontal vented gas fueled equipment, the installing plumber or gas fitter shall observe that a hard wired carbon monoxide detector with an alarm and battery back-up is installed on the floor level where the gas equipment is to be installed. In addition, the installing plumber or gas fitter shall observe that a battery operated or hard wired carbon monoxide detector with an alarm is installed on each additional level of the dwelling, building or structure served by the side wall horizontal vented gas fueled equipment. It shall be the responsibility of the property owner to secure the services of qualified licensed professionals for the installation of hard wired carbon monoxide detectors
    - In the event that the side wall horizontally vented gas fueled equipment is installed in a crawl space or an attic, the hard wired carbon monoxide detector with alarm and battery back-up may be installed on the next adjacent floor level.
    - In the event that the requirements of this subdivision can not be met at the time of completion of installation, the owner shall have a period of thirty (30) days to comply with the above requirements; provided, however, that during said thirty (30) day period, a battery operated carbon monoxide detector with an alarm shall be installed.
  - APPROVED CARBON MONOXIDE DETECTORS.** Each carbon monoxide detector as required in accordance with the above provisions shall comply with NFPA 720 and be ANSI/UL 2034 listed and IAS certified.
  - SIGNAGE.** A metal or plastic identification plate shall be permanently mounted to the exterior of the building at a minimum height of eight (8) feet above grade directly in line with the exhaust vent terminal for the horizontally vented gas fueled heating appliance or equipment. The sign shall read, in print size no less than one-half (1/2) inch in size, "GAS VENT DIRECTLY BELOW. KEEP CLEAR OF ALL OBSTRUCTIONS."
- INSPECTION.** The state or local gas inspector of the side wall horizontally vented gas fueled equipment shall not approve the installation unless, upon inspection, the inspector observes carbon monoxide detectors and signage installed in accordance with the provisions of 248 CMR 5.08(2)(a) 1 through 4.
- EXEMPTIONS:** The following equipment is exempt from 248 CMR 5.08(2)(a)1 through 4:
  - The equipment listed in Chapter 10 entitled "Equipment Not Required To Be Vented" in the most current edition of NFPA 54 as adopted by the Board; and
  - Product Approved side wall horizontally vented gas fueled equipment installed in a room or structure separate from the dwelling, building or structure used in whole or in part for residential purposes.
- MANUFACTURER REQUIREMENTS — GAS EQUIPMENT VENTING SYSTEM PROVIDED.** When the manufacturer of Product Approved side wall horizontally vented gas equipment provides a venting system design or venting system components with the equipment, the instructions provided by the manufacturer for installation of the equipment and the venting system shall include:
  - Detailed instructions for the installation of the venting system design or the venting system components; and
  - A complete parts list for the venting system design or venting system.
- MANUFACTURER REQUIREMENTS — GAS EQUIPMENT VENTING SYSTEM NOT PROVIDED.** When the manufacturer of a Product Approved side wall horizontally vented gas fueled equipment does not provide the parts for venting the flue gases, but identifies "special venting systems", the following requirements shall be satisfied by the manufacturer:
  - The referenced "special venting system" instructions shall be included with the appliance or equipment installation instructions; and
  - The "special venting systems" shall be Product Approved by the Board, and the instructions for that system shall include a parts list and detailed installation instructions.
- A copy of all installation instructions for all Product Approved side wall horizontally vented gas fueled equipment, all venting instructions, all parts lists for venting instructions, and/or all venting design instructions shall remain with the appliance or equipment at the completion of the installation.



# 3d Venting — direct exhaust — vent starter

1. Select a vent pipe manufacturer and obtain all vent components needed, based on boiler location and venting method.
2. You must use the vent starter made by the vent pipe manufacturer. See separate **CGi, & GV Vent Component Supplement**, for part number of each component, listed by vent manufacturer.
3. Follow all applicable national, state, local or provincial codes when venting the CGi boiler.
4. Connect vent starter to blower housing outlet as shown in the **Figures 8 through 11**.
  - a. Do not mix components from different vent manufacturers.
  - b. Maintain minimum 2" clearance from combustible materials to vent pipe.
  - c. Seal with sealant specified by vent pipe manufacturer, using  $\frac{3}{8}$ " bead (not required for FasNSeal™).
  - d. Tighten strap at band clamp screw until strap is snug around blower housing.
  - e. Place blower cover over blower and fasten with four (4) screws. (Blower cover not shown for clarity).



Use only the vent starter of the same manufacturer as the vent components. Do not mix components from different systems. The vent system could fail, causing flue gas spillage, resulting in severe personal injury or death.

**Figure 8**  
FasNSeal™  
vent starter

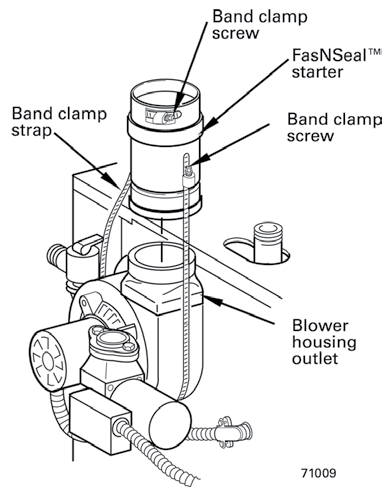

**Figure 10**  
Saf-T Vent®  
vent starter

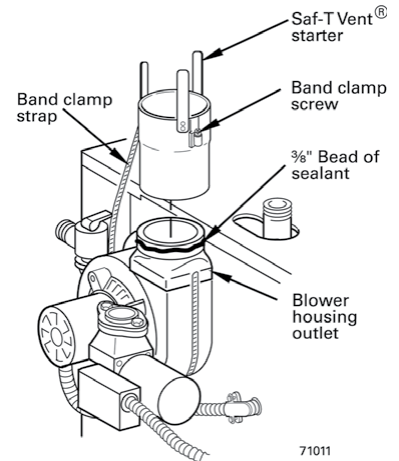

**Figure 9**  
Z-Vent II  
vent starter

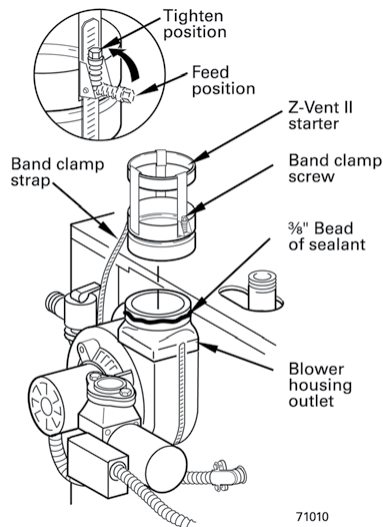

**Figure 11**  
StaR-34  
vent starter

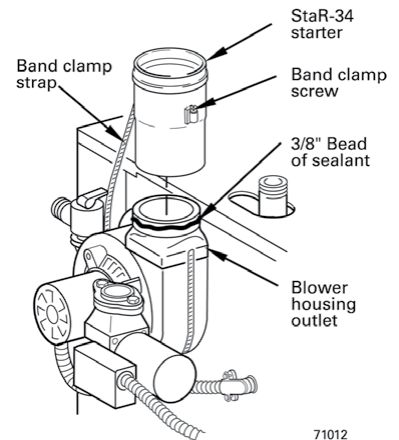

# 3e Venting — direct exhaust — termination

The vent termination must be located to meet all requirements below (also applies to vertical vent terminations). The minimum distance from adjacent public walkways, adjacent buildings, openable windows and building in the National Fuel Gas Code, ANSI Z223.1/NFPA 54 – latest edition and/or the Natural Gas and Propane Installation Code, CAN/CSA B149.1. The vent termination clearances below are for U.S.A., for Canadian vent termination clearances please refer to the requirements of CSA B149.1 Natural Gas and Propane Installation Code. Consideration should be given to avoid possible damage caused by vent plumes and condensate when choosing a venting configuration and location. Maintain a minimum clearance of 4 ft. (1.22m) horizontally from, and in no case above or below, unless a 4 ft. (1.22m) horizontal distance is maintained, from electrical meters, gas meters, regulators, and relief equipment.

**▲WARNING** Follow instructions on this page when determining vent location to avoid possibility of severe personal injury, death or substantial property damage.

1. Locate the boiler and vent penetration through the wall so all requirements on this page and in Figure 12 will be met. Also follow vent manufacturer's instructions.
2. Gases will form white plume in winter. Plume could obstruct window view.
3. Prevailing winds could cause freezing of condensate and water/ice buildup on vent termination, building, plants or roof. Ice buildup on vent termination can cause boiler shutdown and building freeze up.
4. Winds over 31 mph can cause nuisance boiler shutdown if boiler is sidewall vented. This could result in loss of heat to building, causing freeze up.
5. Locate or guard vent termination to prevent condensate from damaging exterior surfaces.
6. Locate the vent termination well away from trees, shrubs, and decorative items.
7. Locate or guard vent to prevent accidental contact by people or pets.
8. Do not terminate vent in window well, stairwell, alcove, courtyard, or other recessed areas.
9. Do not wrap or insulate vent pipe or fittings.
10. Do not terminate vent above any door or window. Condensate can freeze, causing ice formations.
11. Do not connect:
  - Any other appliance to vent pipe.
  - Multiple boilers to a common vent pipe.
12. Canadian installations — See B149.1 or B149.2 Natural Gas and Propane Installation Code. Terminate vent no less than 6 feet from another combustion air inlet, 3 feet from any other building opening, and 3 feet from any gas service regulator.
13. See **Figure 12**, showing that the vent must terminate:
  - more than 4 feet below or to side of all doors or windows.
  - more than 1 foot above grade or anticipated snow line.
  - at least 7 feet above public walkway.
  - 3 feet above any forced air intake within 10 feet.
14. Vent must also terminate:
  - at least 6 feet away from adjacent walls.
  - no closer than 5 feet below roof overhang.
  - at minimum of 4 feet horizontally (and in no case above or below unless a 4 foot horizontal distance is maintained) from electric meters, gas meters, regulators, relief valves, and other equipment.
15. Site conditions may dictate greater clearances.
16. Do not extend exposed vent pipe outside of building more than 4 feet.
 

Condensate could freeze and block vent pipe.

**▲WARNING** A gas vent extending through an exterior wall shall not terminate adjacent to the wall or below building extensions such as eaves, parapets, balconies or decks. Failure to comply could result in severe personal injury, death or substantial property damage.

**Figure 12** Vent termination minimum clearances

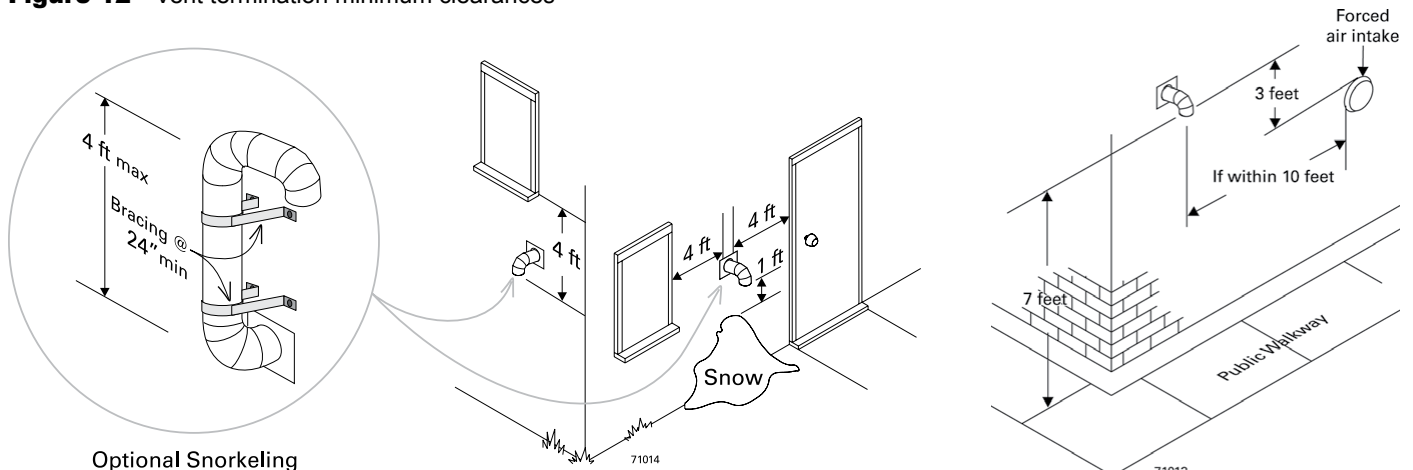

# 3f Venting — direct exhaust — installation

1. Do not mix types or manufacturers of vent materials.
2. Clean all joints before sealing. See vent manufacturer's instructions for cleaning and sealing joints. Use their specified sealant. Do not use screws.
3. Install vent pipe with seams on top of vent horizontal runs. Follow requirements in Section 3e for vent termination.
4. Maintain minimum 2" clearance from combustible materials to vent pipe.
5. **Vertical venting** — See **Figure 13**. Follow vent manufacturer's instructions for venting through roof.
  - Vent pipe must extend through roof flashing, jacket or thimble.
  - Vent may pass through floor, inside wall or concealed space when installed according to vent manufacturer's instructions.
6. **Sidewall venting** — See **Figures 14 and 15**. Vent must terminate at least one foot above anticipated snow line. Vent must be terminated only with:
  - Tee or elbow with integral screen. (Tee may be mounted either vertically or horizontally. **DO NOT** use horizontal tee with CGi-7 or CGi-8.)
  - Elbow and termination coupling with screen (not available for StaR-34).
6. Do not seal vent pipe (slip connector for Saf-T Vent) to inside or outside plate.
7. If passing through noncombustible wall, provide hole diameter large enough to insert the vent pipe (slip connector for Saf-T Vent).
8. Install horizontal drain tee as close as possible to boiler, in first horizontal run. See **Figures 13 and 14**.
9. Do not exceed the maximum vent system length given in **Table 4**, page 15.

**Figure 13** Direct exhaust vertical venting

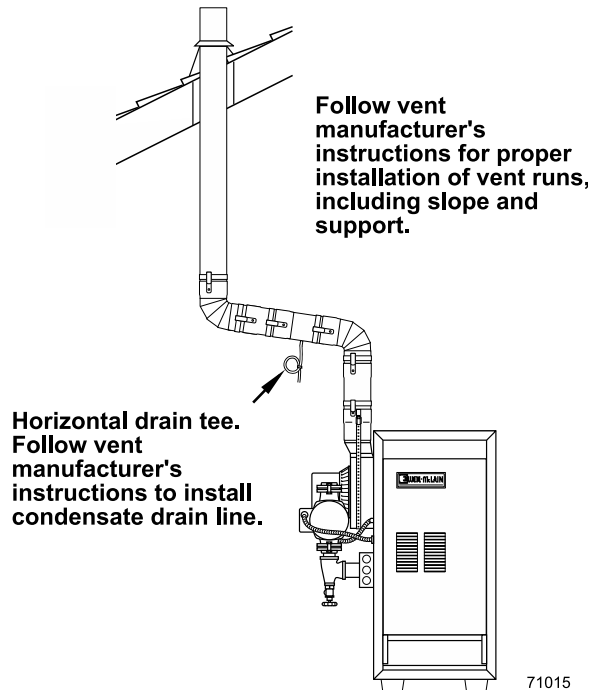

71015

**Figure 14** Direct exhaust sidewall venting

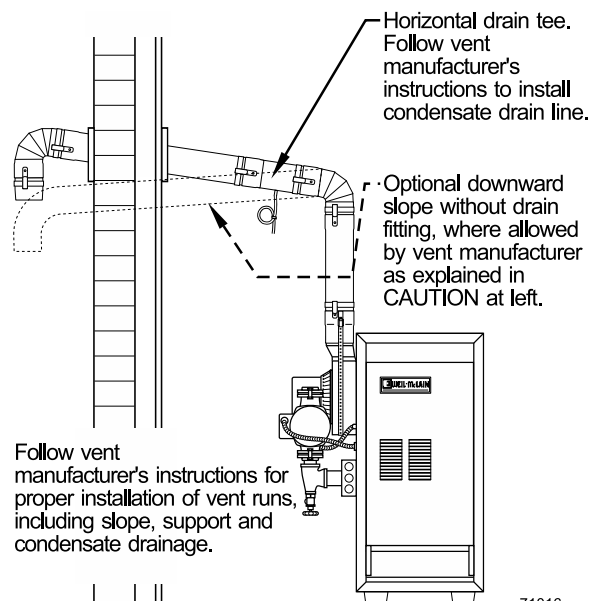

71016

**WARNING**

Condensate drain line — use only silicone tubing rated for at least 400°F for the first 18" of condensate drain line, then other non-metallic tubing may be used. Using any other material could cause flue gas leakage, potentially resulting in severe personal injury, death or substantial property damage.

**CAUTION**

On some installations, the condensate drain fitting may be omitted, provided:

- Vent manufacturer shows this option in their instructions.
- Vent is sloped toward termination as shown in dotted lines in **Figure 14**.
- The vent is installed per Weil-McLain and vent manufacturer's instructions.
- Condensate drip page from such vents may accumulate on the ground below. Consider traffic in the area to avoid hazard due to ice accumulation.



# 3f Venting — direct exhaust — installation (cont.)

Figure 15 Sidewall termination



Using any termination other than one of those shown could cause nuisance outages and loss of heat, resulting in substantial property damage.

<p style="writing-mode: vertical-rl; transform: rotate(180deg);">Saf-T Vent®</p>	<p>Termination elbow or tee</p> <p>Sealant</p> <p>Note 1</p>	<p>Elbow and termination coupling with screen</p> <p>Sealant</p>	<p>18" Slip connector</p> <p>Metal plate</p> <p>Exterior wall</p> <p>Metal plate</p> <p>Sealant</p> <p>Band clamp</p> <p>Pipe section</p> <p>Note 1: DO NOT use horizontal tee with CGi-7 or CGi-8.</p>
<p style="writing-mode: vertical-rl; transform: rotate(180deg);">Z-Vent II</p>	<p>Termination elbow or tee</p> <p>Sealant</p> <p>Note 1</p>	<p>Elbow and termination coupling with screen</p> <p>Sealant</p>	<p>Sealant</p> <p>Pipe section</p> <p>Metal plate</p> <p>Exterior wall</p> <p>Metal plate</p> <p>Pipe section</p> <p>Note 1: DO NOT use horizontal tee with CGi-7 or CGi-8.</p>
<p style="writing-mode: vertical-rl; transform: rotate(180deg);">StaR-34</p>	<p>Termination elbow or tee</p> <p>Sealant</p> <p>Note 1</p>	<p>Termination coupling not available</p>	<p>Sealant</p> <p>Pipe section</p> <p>Metal plate</p> <p>Exterior wall</p> <p>Metal plate</p> <p>Pipe section</p> <p>Note 1: DO NOT use horizontal tee with CGi-7 or CGi-8.</p>
<p style="writing-mode: vertical-rl; transform: rotate(180deg);">FasNSeal™</p>	<p>Termination elbow or tee</p> <p>Note 1</p>	<p>Elbow and termination coupling with screen</p> <p>Locking band</p>	<p>Pipe section</p> <p>Metal plate</p> <p>Exterior wall</p> <p>Metal plate</p> <p>Pipe section</p> <p>Note 1: DO NOT use horizontal tee with CGi-7 or CGi-8.</p>

71017



# 4a Water piping — general information

## General piping information

If installation is to comply with ASME or Canadian requirements, an additional high temperature limit maybe needed. Install control in supply piping between boiler and isolation valve. Set second control to minimum 20°F above setpoint of first control. Maximum allowable setpoint is 240°F. See Section 9b for wiring.

Use backflow check valve in cold water supply as required by local codes.

## Water temperature/LWCO sensor

A low water cutoff device is required when boiler is installed above radiation level or by certain state or local codes or insurance companies. The boiler has a pre-installed water temperature/LWCO sensor.

## Pressure/temperature gauge

Install pressure/temperature gauge in tee on supply piping (as shown in drawing on page 3).

## Isolation valves

Isolation valves are required to enable servicing of the boiler's temperature sensor. Install as shown in appropriate piping diagram.

## Relief valve

Install relief valve vertically in 3/4" tapping on side of boiler. See Figure 16 or 17, page 21, and the tag attached to the relief valve for manufacturer's instructions.

### ⚠ WARNING

To avoid water damage or scalding due to relief valve operation:

- Discharge line must be connected to relief valve outlet and **run to a safe place of disposal**. Terminate the discharge line to eliminate possibility of severe burns should the valve discharge.
- Discharge line must be as short as possible and be the **same size as the valve discharge connection** throughout its entire length.
- Discharge line must **pitch downward** from the valve and terminate at least 6" above the floor drain where any discharge will be clearly visible.
- The discharge line shall **terminate plain, not threaded**, with a material serviceable for temperatures of 375°F or greater.
- **Do not pipe the discharge to any place where freezing could occur.**
- **No shutoff valve** shall be installed between the relief valve and boiler, or in the discharge line. Do not plug or place any obstruction in the discharge line.
- **Failure to comply** with the above guidelines could result in failure of the relief valve to operate, resulting in possibility of severe personal injury, death or substantial property damage.
- **Test the operation of the valve** after filling and pressurizing system by lifting the lever. Make sure the valve discharges freely. If the valve fails to operate correctly, replace it with a new relief valve.

## Circulator

The circulator is shipped loose (wiring pre-attached to boiler) to allow you to locate it either in the return or supply piping, as desired. See page 3 for a typical installation. Pipe the expansion tank to the suction side of the circulator whenever possible. Install an air separator in the supply piping. Connect the expansion tank to the air separator only if the separator is on the suction side of the circulator. Always install the system fill connection at the same point as the expansion tank connection to the system. Figures 16 and 17 show typical near-boiler piping connections.

## System water piping

See Figure 16 (diaphragm-type or bladder-type expansion tank) or Figure 17 (closed-type expansion tank) and Table 6, for near-boiler and single-zone systems designed for return water at least 130°F.

See pages 22-23 to complete multiple-zone piping or pages 24-29 to complete piping for radiant heating systems or converted gravity systems (large-volume systems originally designed for circulation by natural convection rather than a pump). See page 29 for boilers used with refrigeration systems.

**Table 6** Water pipe size (based on 20°F rise)

Boiler model number	To system	From system
CGi-25	3/4"	3/4"
CGi-3, 4, 5	1"	1"
CGi-6, 7	1 1/4"	1 1/4"
CGi-8	1 1/2"	1 1/2"

Note: The boiler supply and return connections, the return/drain tee and the supply/gauge tee supplied with the boiler are 1 1/4" NPT. One of the circulator flanges supplied with the boiler is 1 1/4". The other circulator flange is the size of the recommended system piping shown above.

### ⚠ WARNING

**Chillers or air handling units:**  
Install boiler such that —

- Chilled medium, if used, is piped in parallel with heating boiler. Use appropriate valves to prevent chilled medium from entering boiler. Consult AHRI Installation and Piping Guides.
- If boiler is connected to heating coils located in air handling units where they can be exposed to refrigerated air, use flow control valves or other automatic means to prevent gravity circulation during cooling cycle. Circulation of cold water through the boiler could result in damage to the heat exchanger, causing possible severe personal injury, death or substantial property damage.

# 4b Water piping — single-zone system



Undersized expansion tanks cause system water to be lost from relief valve and makeup water to be added through fill valve. Eventual section failure can result.

## Diaphragm-type or bladder-type expansion tank (Figure 16)

1. Ensure expansion tank size will handle boiler and system water volume and temperature. Tank must be located in boiler return piping as close to boiler as possible, before inlet side of circulator. See tank manufacturer's instructions for details.
2. Install an **automatic air vent** as shown.

## Closed-type expansion tank (Figure 17)

1. Ensure expansion tank size will handle boiler and system water volume and temperature. See tank manufacturer's instructions for details.
2. Connect tank to  $\frac{1}{2}$ " NPT tapping located behind supply outlet, using  $\frac{1}{2}$ " NPT piping. Pitch any horizontal piping up towards tank 1 inch per 5 feet of piping.



Use **Figure 16** or **Figure 17** only for single-zone systems designed for return water at least 130°F. For systems with low return water temperature possible, such as converted gravity systems and radiant heating systems, refer to the special piping suggestions of pages 24-29. Failure to prevent low return water temperature to the boiler could cause corrosion of the boiler sections or burners, resulting in severe personal injury, death or substantial property damage.

**Figure 16** Diaphragm- or bladder-type expansion tank — Piping to single-zone system using diaphragm-type or bladder-type expansion tank. See Table 6 for piping sizes.

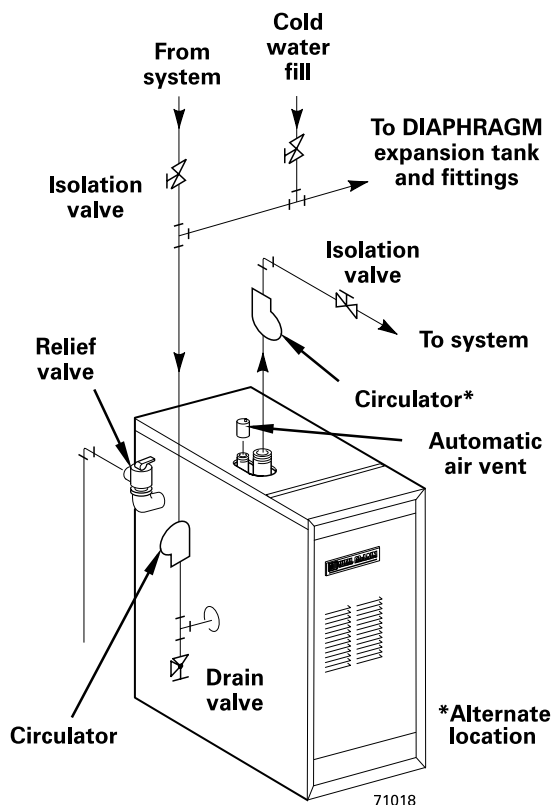

**Figure 17** Closed-type expansion tank — Piping to single-zone system using closed-type expansion tank. See Table 6 for piping sizes.

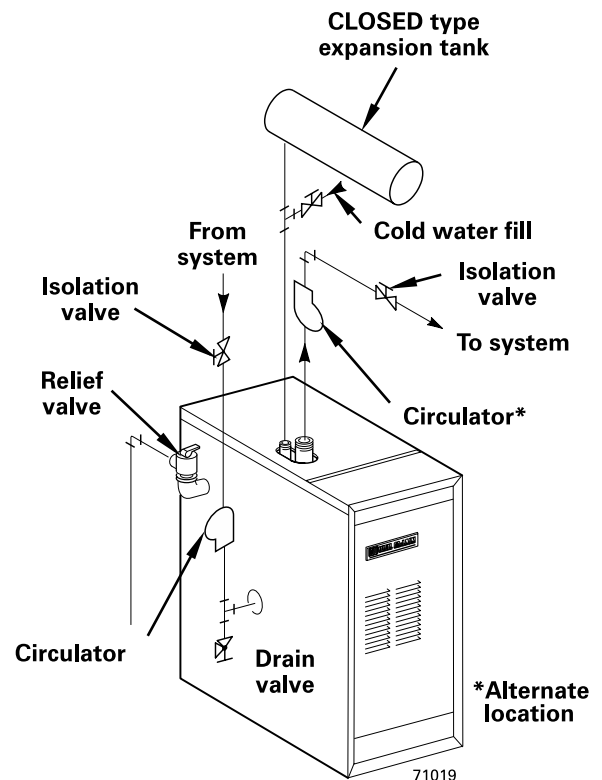



# 4c Water piping — multiple zones

## Piping multiple zones

Follow instructions on pages 20 and 21 to install near-boiler or single-zone piping. (Also refer to **Piping for radiant heating systems or converted gravity systems**, below, if applicable.)

See **Figure 18** or **Figure 19** to complete installation.

### Zoning with circulators (**Figure 18**) (return temp over 130°F)

1. Size each circulator to individual circuit requirements.
2. Do not install circulator on boiler (except for primary/secondary piping).
3. Install isolation (balancing) valves to adjust flow to distribute heat to all zones.
4. Install and wire a separate relay for each zone circulator.

### Zoning with zone valves (**Figure 19**) (return temp over 130°F)

1. Install isolation (balancing) valves to adjust flow to distribute heat to all zones.
2. Provide a separate 24-volt transformer to power the zone valves. Size the transformer to handle the total rated load of all connected zone valves.

**CAUTION** **DO NOT connect directly from 3-wire zone valves to the T-T terminals on the boiler.** When using 3-wire zone valves, install an isolation relay. Connect the zone valve end switch wires to the isolation relay coil. Connect the isolation relay contact across the boiler T-T terminals. Failure to comply can result in damage to boiler components or cause unreliable operation, resulting in severe property damage.

## Piping for radiant heating systems or converted gravity systems

### Converted gravity (or steam) systems

Whenever possible, use the primary/secondary piping shown in **Figures 20 or 21** on page 25. This piping design allows changing boiler flow rate without affecting primary circuit flow rate.

If **Figures 20 or 21** cannot be used, use the boiler-by-pass piping shown in **Figure 22 or Figure 23** on page 27. You can also use the piping shown in **Figure 24** on page 29 (system-bypass), if the reduced flow rate in the heating system will not cause heat distribution problems.

#### **WARNING**

Failure to prevent low return water temperature to the boiler could cause corrosion of the boiler sections or burners, resulting in severe personal injury, death or substantial property damage.

### Radiant heating systems

Preferably, use primary/secondary piping, as shown in **Figures 20 or 21** on page 25. Alternatively, use the method of either **Figure 22 or Figure 23** on page 27. **Do not use the piping of Figure 24** (system-bypass), because this method does not control radiant system supply temperature.

If radiant system tubing has no oxygen barrier, a **heat exchanger** must be used.

**WARNING** Radiant heating system piping should include a means of regulating the boiler return water temperature and the system supply temperature (such as provided by an injection pumping control). Boiler return water temperature will be adequately controlled using the methods shown in this manual provided the system supply temperature is relatively constant.

**DO NOT** apply the methods in this manual if the system is equipped with an **out-door reset control**. Instead, provide controls and piping which can regulate the boiler return water temperature at no less than 130°F regardless of system supply temperature. Contact your Weil-McLain representative for suggested piping and control methods. Failure to prevent cold return water temperature to the boiler could cause corrosion damage to the sections or burners, resulting in possible severe personal injury, death or substantial property damage.1

# 4c Water piping — multiple zones (continued)

**Figure 18** Zoning with circulators  
— return water 130°F or higher.

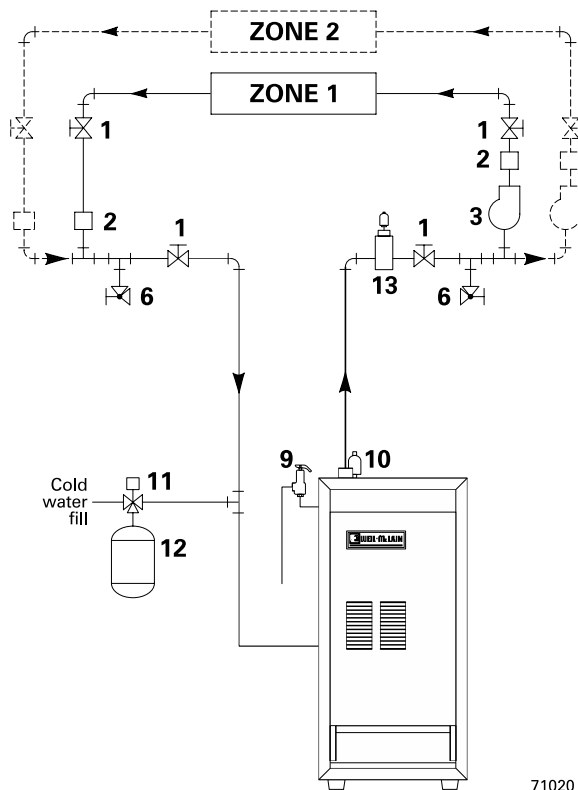

**Figure 19** Zoning with zone valves  
— return water 130°F or higher.

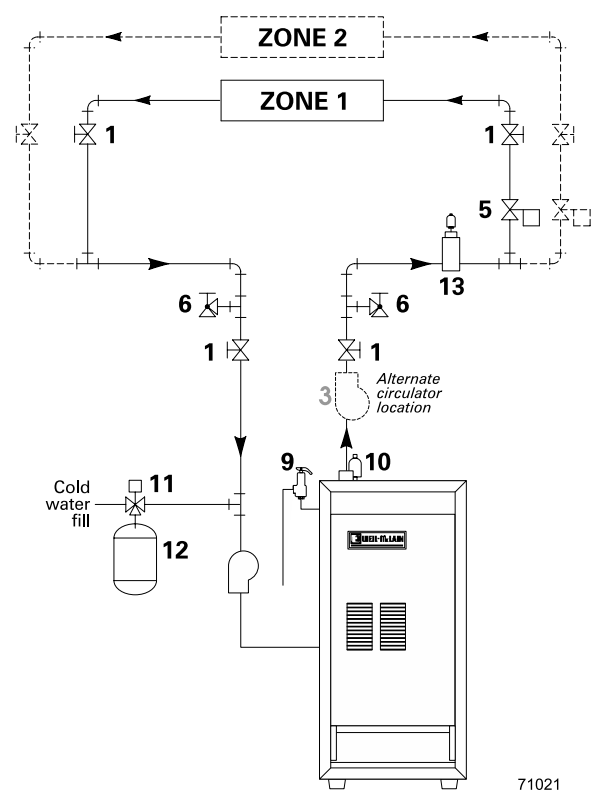

- |  |  |
|--|--|
| <p>1 Boiler isolation (balancing) valves</p> <p>2 Flow/check valve</p> <p>3 System or zone circulator</p> <p>5 Zone valve</p> <p>6 Drain valve</p> <p>9 Relief valve</p> | <p>10 Automatic air vent (with diaphragm-type expansion tank), or connect to tank fitting (closed-type expansion tank). <b>DO NOT</b> use an automatic air vent when using closed-type expansion tank. It would allow air to leave the system, causing waterlogging of the expansion tank.</p> <p>11 Fill valve</p> <p>12 Diaphragm-type or bladder-type expansion tank, if used (For closed-type expansion tank, pipe from top of air separator to tank fitting as in Figure 17.)</p> <p>13 Air separator and automatic vent, if used (Note that the fill valve must always be connected to the expansion tank, regardless of location of expansion tank circulator or air separator.</p> |
|--|--|

**WARNING**

For systems with possible low return-water temperature (such as converted gravity systems, radiant heating systems and heat pump systems), refer to the special piping suggestions of Figures 20 – 24, as applies. Failure to prevent sustained low return water temperature to the boiler could cause corrosion of the boiler sections, resulting in severe personal injury, death or substantial property damage.



# 4d Piping — low temperature systems

## Primary/secondary (preferred) bypass piping method

**Primary/secondary** bypass piping is preferred because the flow rate and temperature drop in the heating circuit(s) is determined only by the heating circuit circulator(s). So adjustment of the bypass valves in the boiler circuit will not cause a change in the heating circuit rate and temperature distribution.

**Figures 20 and 21** show suggested bypass arrangements using **primary/secondary** bypass piping (preferred) for low temperature systems such as **radiant heating systems** or **converted gravity systems**. For alternatives, see pages 26 through 29.

The bypass valves (items **7a** and **7b**) provide mixing of hot boiler outlet water with cooler system return water — set to assure a minimum return water temperature (at least 130°F) to the boiler. Set the valves as explained below.

### Temperature gauges

Gauge **4a** is suggested, but optional on any system.

Gauge **4b** is optional on converted gravity systems, but **required** on radiant heating systems — to display the water temperature being sup-

plied to the radiant tubing.

Gauge **8** is **required** on all systems to assure the return water temperature is accurately set for a minimum of 130°F. If this gauge is not available however, adjust the valves such that the boiler-mounted temperature/pressure gauge reads at least 150°F when the system return water is cold (approximately 60°F water temperature).

### Valve adjustment (Figures 20 and 21 only)

1. Set the valves while the system is cool, setting for the coldest expected water temperature (usually 60°F since the system will often drop to room temperature between cycles).
2. Start with valve **7a** fully closed and **7b** fully open.
3. Gradually open valve **7a** while closing valve **7b** until the temperature at gauge **8** reads 130°F when gauge **4a** reads 60°F.
4. Note that valve **7a** regulates the amount of hot water from the boiler supply which mixes with return water. Valve **7b** regulates the amount of system water flowing through the boiler secondary loop.

#### **WARNING**

Failure to **prevent low return water temperature** to the boiler could cause corrosion of the boiler sections or burners, resulting in severe personal injury, death or substantial property damage.

Radiant heating system piping should include a means of **regulating the boiler return water temperature** and the **system supply temperature** (such as provided by an **injection pumping control**).

Boiler return water temperature will be adequately controlled using the methods shown in this manual provided the **system supply temperature** is **relatively constant**.

**DO NOT** apply the methods of this manual if the system is equipped with an **outdoor reset control**. Instead, **provide controls and piping** which can **regulate the boiler return water temperature** at **no less than 130°F** regardless of system supply temperature. Contact your Weil-McLain representative for suggested piping and control methods.

Failure to **prevent cold return water temperature** to the boiler could cause corrosion damage to the sections or burners, resulting in possible severe personal injury, death or substantial property damage.

# 4d Piping — low temperature systems (continued)

**Figure 20** Primary/secondary piping  
Zoning with circulators

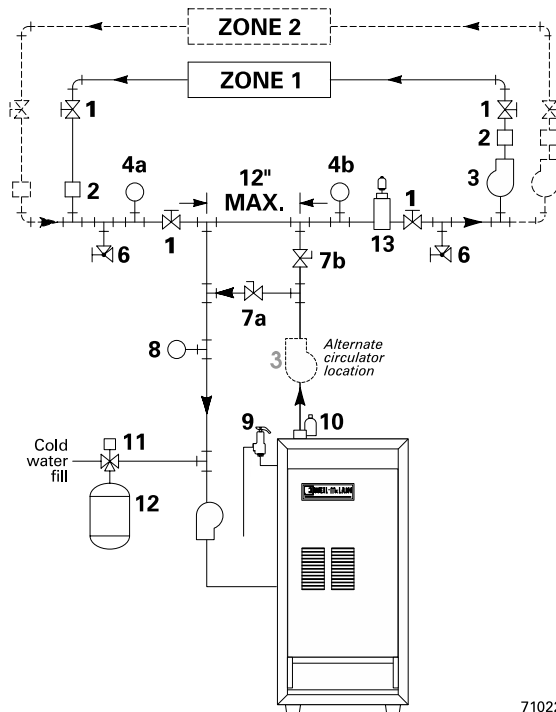

**Figure 21** Primary/secondary piping  
Zoning with zone valves

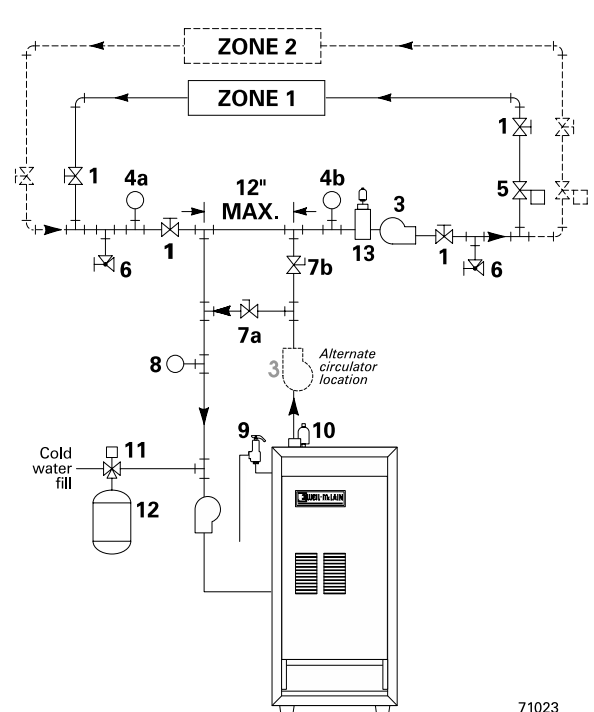

- 1 Boiler isolation (balancing) valves
- 2 Flow/check valve
- 3 System or zone circulator
- 4 System temperature gauges
- 5 Zone valve
- 6 Drain valve
- 7 System temperature valves (see instructions to the left for adjusting valves)
- 8 Blend temperature gauge

- 9 Relief valve
- 10 Automatic air vent (with diaphragm-type expansion tank), or connect to tank fitting (closed-type expansion tank). **DO NOT** use an automatic air vent when using closed-type expansion tank. It would allow air to leave the system, causing waterlogging of the expansion tank.
- 11 Fill valve
- 12 Diaphragm-type or bladder-type expansion tank, if used (For closed-type expansion tank, pipe from top of air separator to tank fitting as in **Figure 17**.)
- 13 Air separator and automatic vent, if used (Note that the fill valve must always be connected to the expansion tank, regardless of location of expansion tank, circulator or air separator.)



# 4d Piping — low temperature systems (continued)

## BOILER-bypass piping method

This piping method (**Figure 22** or **23**) is called a **boiler-bypass** because part of the circulator flow is bypassed around the boiler (through valve **7a**). This method reduces the flow rate throughout the boiler, in order to raise the average water temperature in the boiler enough to prevent flue gas condensation. Boiler-bypass piping is effective for some boilers — including the CGi — provided the flow rates are adjusted according to the instructions following.

**Figures 22** and **23** are alternative piping suggestions for **converted gravity** (large water content or steam systems) or **radiant heating system** — for use when primary/secondary piping can't be applied. (**Figure 24** is another alternative, using system bypass in place of boiler-bypass piping. **Figure 24** however, is not suitable for radiant heating applications because it does not protect the radiant system from possible high water temperature.)

Boiler-bypass piping keeps system flow rate as high as possible and temperature drop as low as possible, helping to equalize the building heat distribution.

## Temperature gauges

Gauge **4a** is optional if the bypass valves will be adjusted using cold (or room temperature) return water to the boiler. (When setting the valves without gauge **4a** installed — using cold or room temperature water — assume the return water temperature to be 60°F. Set the valves so gauge **8** reads at least 120°F.

Gauge **4b** is optional on converted gravity systems, but **required** on radiant heating systems — to display the water temperature being supplied to the radiant tubing.

Gauge **8** is **required** on all systems to assure reliable adjustment of the bypass valves. The boiler-mounted temperature/pressure gauge can be used if a separate temperature gauge is not installed.

## Valve adjustment

1. Start with valve **7a** fully closed and **7b** fully open.
2. Gradually open valve **7a** while closing valve **7b** until the temperature at gauge **8** reads 60 °F higher than gauge **4a**. A minimum 60°F temperature rise through the boiler assures a low enough flow rate and high enough average temperature to prevent condensation even with low system return water temperature.
3. Valve **7a** regulates the system flow rate, while valve **7b** regulates the boiler flow rate.
4. The boiler-mounted temperature/pressure gauge may be used in place of a separate gauge **8**.

### **WARNING**

Failure to **prevent low return water temperature** to the boiler could cause corrosion of the boiler sections or burners, resulting in severe personal injury, death or substantial property damage.

Radiant heating system piping should include a means of **regulating the boiler return water temperature** and the **system supply temperature** (such as provided by an **injection pumping control**).

Boiler return water temperature will be adequately controlled using the methods shown in this manual provided the **system supply temperature** is **relatively constant**.

**DO NOT** apply the methods of this manual if the system is equipped with an **outdoor reset control**. Instead, **provide controls and piping** which can **regulate the boiler return water temperature** at no less than 130°F regardless of system supply temperature. Contact your Weil-McLain representative for suggested piping and control methods.

Failure to **prevent cold return water temperature** to the boiler could cause corrosion damage to the sections or burners, resulting in possible severe personal injury, death or substantial property damage.



# 4d Piping — low temperature systems (continued)

**Figure 22** Boiler-bypass piping — Zoning with circulators — (Alternative to primary/secondary piping Figures 20 and 21)

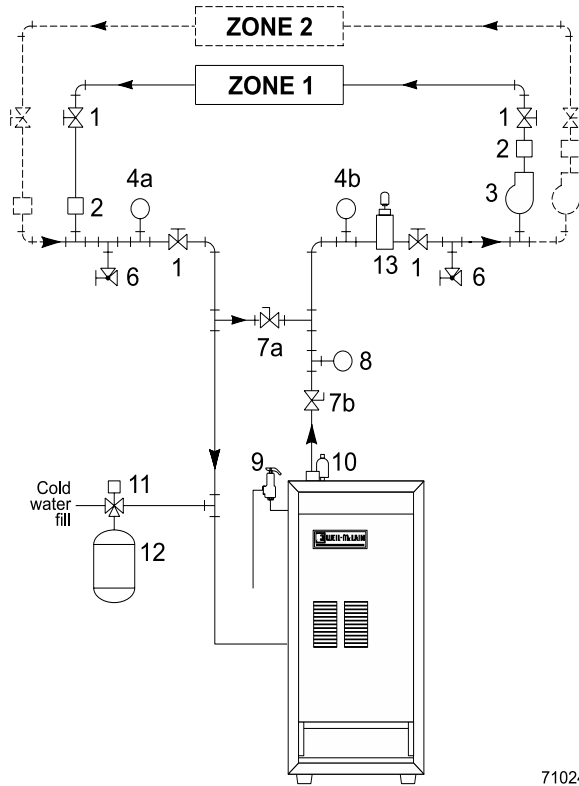

**Figure 23** Boiler-bypass piping — Zoning with zone valves — (Alternative to primary/secondary piping Figures 20 and 21)

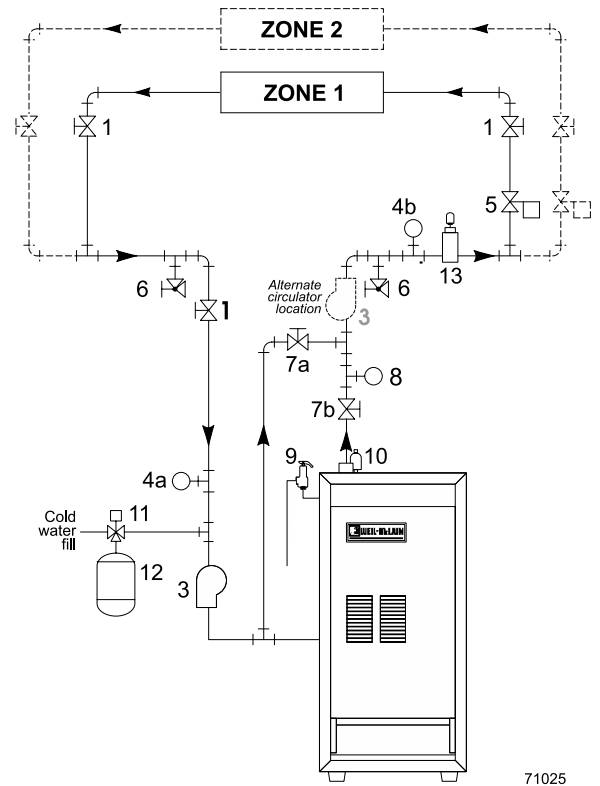

- |   |   |
|---|---|
| 1 Boiler isolation (balancing) valves   | 9 Relief valve  |
| 2 Flow/check valve  | 10 Automatic air vent (with diaphragm-type expansion tank), or connect to tank fitting (closed-type expansion tank). <b>DO NOT</b> use an automatic air vent when using closed-type expansion tank. It would allow air to leave the system, causing waterlogging of the expansion tank. |
| 3 System or zone circulator   | 11 Fill valve   |
| 4 System temperature gauges   | 12 Diaphragm-type or bladder-type expansion tank, if used (For closed-type expansion tank, pipe from top of air separator to tank fitting as in <b>Figure 17</b> , page 21).  |
| 5 Zone valve  | 13 Air separator and automatic vent, if used (Note that the fill valve must always be connected to the expansion tank, regardless of location of expansion tank, circulator or air separator.)  |
| 6 Drain valve   |   |
| 7 System temperature valves (see instructions to the left for adjusting valves) |   |
| 8 Blend temperature gauge   |   |



# 4d Piping — low temperature systems (continued)

## SYSTEM-bypass piping method

This piping method is called a **system-bypass** because part of the circulator flow bypasses the system (through valve **7a**). This bypassed hot water from the boiler outlet mixes with cooler system return water temperature in order to provide minimum 130°F return water to the boiler. Valve **7b** will most often be full open, but may need to be slightly closed on some low pressure drop systems in order to cause enough flow through valve **7a**.

**Figure 24** is an alternative piping method that provides return water temperature control for boilers installed on **converted gravity systems** (large water content or steam systems).

**Do not** apply the piping of **Figure 24** on **radiant heating systems**. It provides no method regulating the water temperature provided to the system and could result in excessive water temperature in the radiant tubing.

System-bypass piping as shown in **Figure 24** can be used with either zone valve or circulator zoning. When used with circulator zoning however, the boiler circulator (item **3**), must be piped as shown.

It cannot be used as one of the zoning circulators.

Do not apply system-bypass piping if the reduced flow in the system could cause poor heat distribution. That is, system-bypass piping reduces the flow in the system and increases the water temperature supplied to the system. This can cause increased heat from radiators at the beginning of the system and reduced heat from radiators near the end of the system.

## Valve adjustment

1. Start with valve **7a** fully closed and **7b** fully open.
2. Gradually open valve **7a** while closing valve **7b** until the temperature at gauge **8** reads at least 130°F at all times.
3. Valve **7a** regulates the amount of boiler supply water mixed with return water. Valve **7b** causes a pressure drop in the system needed to balance flow through valve **7a** and the system.
4. The valve adjustment should be done with the system at the coldest expected temperature (60°F for converted gravity systems or high mass radiant systems).

### WARNING

Failure to **prevent low return water temperature** to the boiler could cause corrosion of the boiler sections or burners, resulting in severe personal injury, death or substantial property damage.

Radiant heating system piping should include a means of **regulating the boiler return water temperature** and the **system supply temperature** (such as provided by an **injection pumping control**).

Boiler return water temperature will be adequately controlled using the methods shown in this manual provided the **system supply temperature** is **relatively constant**.

**DO NOT** apply the methods of this manual if the system is equipped with an **outdoor reset control**. Instead, **provide controls and piping** which can **regulate the boiler return water temperature** at **no less than 130°F** regardless of system supply temperature. Contact your Weil-McLain representative for suggested piping and control methods.

Failure to **prevent cold return water temperature** to the boiler could cause corrosion damage to the sections or burners, resulting in possible severe personal injury, death or substantial property damage.



# 4d Piping — low temperature systems (continued)

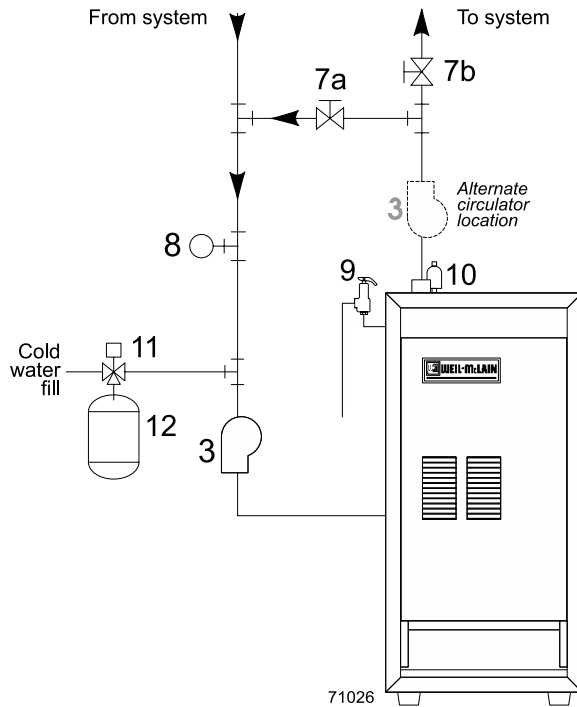
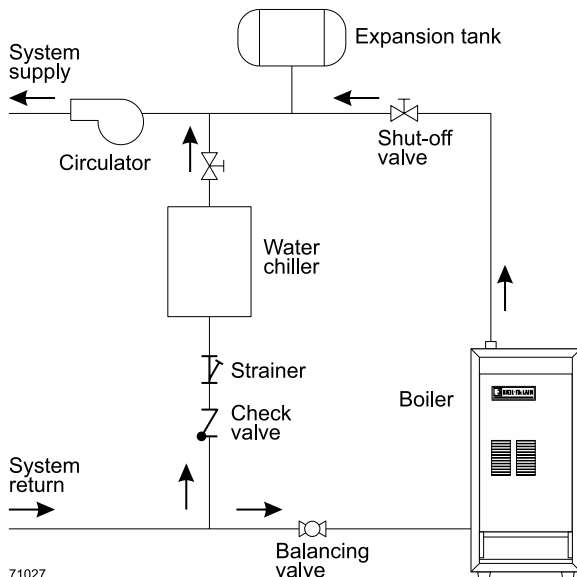

Figure 24 System-bypass piping — Zoning with zone valve or circulators, return water 130°F or higher — (Alternative to boiler-bypass piping Figures 22 and 23)

- 3 System or zone circulator
- 7 System temperature valves (see instructions to the left for adjusting valves)
- 8 Blend temperature gauge
- 9 Relief valve
- 10 Automatic air vent (with diaphragm-type expansion tank), or connect to tank fitting (closed-type expansion tank). **DO NOT** use an automatic air vent when using closed-type expansion tank. It would allow air to leave the system, causing waterlogging of the expansion tank.
- 11 Fill valve
- 12 Diaphragm-type or bladder-type expansion tank, if used (For closed-type expansion tank, pipe from top of air separator to tank fitting as in Figure 17, page 21.)

# 4e Water piping — refrigeration system

Figure 25 Piping refrigeration systems



## Prevent chilled water from entering boiler

**WARNING** Install boiler so that chilled medium is piped in parallel with the heating boiler. Use appropriate valves to prevent chilled medium from entering boiler. See Figure 18 for typical installation of balancing valve and check valve.

**WARNING** If boiler is connected to heating coils located in air handling units where they can be exposed to refrigerated air, use flow control valves (see Figure 25) or other automatic means to prevent gravity circulation during cooling cycle.



# 5 Gas piping

## Connecting gas supply piping to boiler

1. Remove jacket front panel and refer to **Figure 26** to pipe gas to boiler.
  - a. **Install drip leg** at inlet of gas connection to boiler. Where local utility requires drip leg to be extended to the floor, use appropriate length of pipe between cap and tee.
  - b. **Install ground joint union** for servicing, when required.
  - c. **Install manual shutoff valve** in gas supply piping outside boiler jacket when required by local codes or utility requirements.
  - d. **In Canada** — When using manual main shutoff valve, it **must be identified** by the installer.
2. **Support piping** with hangers, not by boiler or its accessories.
3. **Purge all air** from gas supply piping.
4. Before placing boiler in operation, **check boiler and its gas connection for leaks**.
  - a. **Close manual main shutoff valve** during any pressure testing at less than 13" w.c.
  - b. **Disconnect boiler and gas valve from gas supply piping** during any pressure testing greater than 13" w.c.

**WARNING** Do not check for gas leaks with an open flame — use bubble test. Failure to use bubble test or check for gas leaks can cause severe personal injury, death or substantial property damage.

5. **Use pipe dope compatible with propane gases.** Apply sparingly only to male threads of pipe joints so that pipe dope does not block gas flow.

**WARNING** Failure to apply pipe dope as detailed above can result in severe personal injury, death or substantial property damage.

**Table 7** Pipe capacity for 0.60 specific gravity natural gas

Gas pipe length (feet)	Capacity of pipe for pipe size of: (Capacity in cubic feet gas per hour)				
	½"	¾"	1"	1¼"	1½"
10	132	278	520	1050	1600
20	92	190	350	730	1100
30	73	152	285	590	860
40	63	130	245	500	760
50	56	115	215	440	670
75	45	93	175	360	545
100	38	79	150	305	460
150	31	64	120	250	380

## Natural Gas:

1. Refer to **Table 7** for pipe length and diameter. Base on rated boiler input (divide by 1,000 to obtain cubic feet per hour). **Table 7** is only for gas with **specific gravity 0.60, with a pressure drop through the gas piping of 0.30" w.c.** For additional gas pipe sizing information, refer to ANSI Z223.1/NFPA 54 – latest edition (or B149.1 or B149.2 for Canadian Natural Gas and Propane Installation Code).
2. Inlet pressure required at gas valve inlet:
  - Maximum: 13" w.c.
  - Minimum: 5" w.c.
  - Manifold gas pressure: 3.5" w.c.
3. Install 100% lockup gas pressure regulator in supply line **if inlet pressure exceeds 13" w.c.** Adjust for 13" w.c. maximum.

## Propane Gas:

1. Contact gas supplier to size pipes, tanks and 100% lockup gas pressure regulator.
2. Adjust propane supply regulator provided by gas supplier for 13" w.c. maximum pressure.
3. Inlet pressure required at gas valve inlet:
  - Maximum: 13" w.c.
  - Minimum: 11" w.c.
  - Manifold gas pressure: 10" w.c.

**Figure 26** Gas supply piping

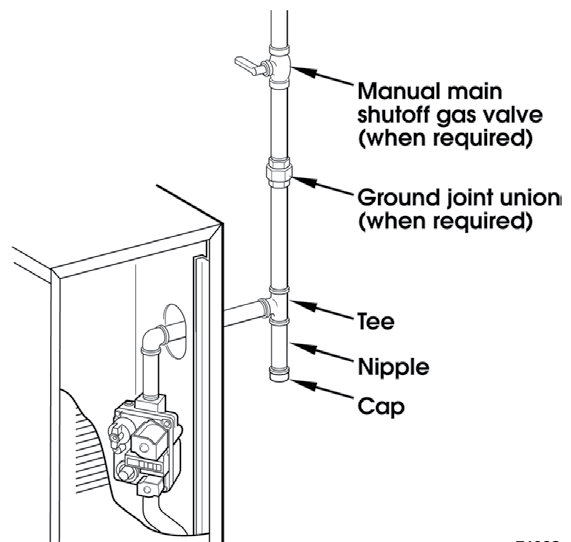

71028

# 6 Field wiring

**WARNING** For your safety, **turn off electrical power supply at service entrance panel before making any electrical connections** to avoid possible electric shock hazard. Failure to do so can cause severe personal injury or death.

## NOTICE

### Wiring must be N.E.C. Class 1.

If original rollout thermal fuse element wire as supplied with boiler must be replaced, use only type **200°C** wire or equivalent. If other original wiring as supplied with boiler must be replaced, type **105°C** wire or equivalent must be used.

Boiler must be **electrically grounded** as required by National Electrical Code ANSI/NFPA 70 –latest edition.

## Electrical installation must comply with:

1. National Electrical Code ANSI/NFPA 70 – latest edition and any other national, state, provincial or local codes or regulations.
2. In Canada, CSA C22.1 Canadian Electrical Code Part 1, and any local codes.

## Wiring connections

Boiler is shipped with controls completely wired.

## Thermostat

1. Connect thermostat as shown on wiring diagram on boiler.
2. **Install on inside wall away from influences of drafts, hot or cold water pipes, lighting fixtures, television, sun rays, or fireplaces.**
3. If thermostat has a heat anticipator, set heat anticipator in thermostat to match power requirements of equipment connected to it. If connected directly to boiler, set for 0.1 amps

plus gas valve current. See information on wiring diagram as shown in **Figure 32**, page 39. For other devices, refer to manufacturer's specifications. Wiring diagram on boiler gives setting for control module and gas valve. Also see instructions with thermostat.

## DHW

Connect DHW aquastat as shown in wiring below. Economy function isn't utilized with DHW input.

## Junction Box (furnished)

1. Connect 120 VAC power wiring as shown in **Figure 27**.
2. Fused disconnect or service switch (15 amp. recommended) may be mounted on this box. For those installations with local codes which prohibit installation of fused disconnect or service switch on boiler, install a 2 x 4 cover plate on the boiler junction box and mount the service switch remotely as required by the code.

## Wiring multiple zones

Refer to zone valve manufacturer's literature for wiring and application. A separate transformer is required to power zone valves. Zoning with circulators requires a relay for each circulator.

## CAUTION

**DO NOT connect directly from 3-wire zone valves to the T-T terminals on the boiler.** When using 3-wire zone valves, install an isolation relay. Connect the zone valve end switch wires to the isolation relay coil. Connect the isolation relay contact across the boiler T-T terminals. Failure to comply can result in damage to boiler components or cause unreliable operation, resulting in severe property damage.

## NOTICE

The CGi control module is polarity-sensitive. The hot and neutral wires must be connected to the correct leads.

A flashing **POWER** light usually indicates reversed polarity of 120 VAC lead wires.

**Figure 27**

Field wiring connections — service switch, DHW (if used) and thermostat (or end switch) provided by installer

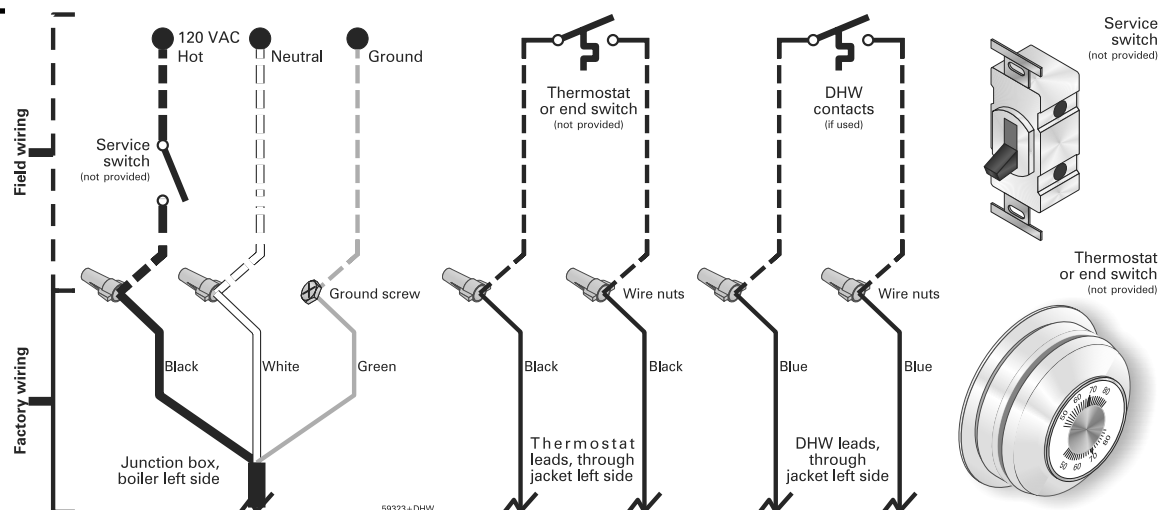



# 7a Start-up — preparation

## Check for gas leaks

**⚠ WARNING**

Before starting the boiler, and during initial operation, smell near the floor and around the boiler for gas odorant or any unusual odor. Do not proceed with start-up if there is any indication of a gas leak. Repair any leak at once.

**⚠ WARNING**

**Propane boilers only** — Your propane supplier mixes an odorant with the propane to make its presence detectable. In some instances, the odorant can fade and the gas may no longer have an odor.

- Propane gas can accumulate at floor level. Smell near the floor for the gas odorant or any unusual odor. If you suspect a leak, do not attempt to light the pilot.
- Use caution when attempting to light the propane pilot. This should be done by a qualified service technician, particularly if pilot outages are common.
- Periodically check the odorant level of your gas.
- Inspect boiler and system at least yearly to make sure all gas piping is leak-tight.
- Consult your propane supplier regarding installation of a gas leak detector. There are some products on the market intended for this purpose. Your supplier may be able to suggest an appropriate device.

## Determine if water treatment is needed

**⚠ DANGER**

Do not use **petroleum-based cleaning or sealing compounds** in boiler system. Severe damage to boiler will occur, resulting in substantial property damage.

**⚠ WARNING**

Eliminate all system leaks. Continual fresh makeup water will reduce boiler life. Minerals can build up in sections, reducing heat transfer, overheating cast iron, and causing section failure.

### Verify water chemistry

Consult local water treatment companies for unusually hard water areas (above 7 grains hardness) or low pH water conditions (below 7.0). Boiler water pH of 7.0 to 8.5 is recommended.

## Freeze protection (when used)

Use antifreeze made especially for hydronic systems. Inhibited propylene glycol is recommended.

**⚠ WARNING**

Do not use **ethylene glycol, automotive or undiluted antifreeze**. Severe personal injury or death can result.

1. Determine **antifreeze quantity** according to system water content. Boiler water content is listed on page 70. Remember to include expansion tank water content.
2. Follow antifreeze manufacturer's instructions.
3. A 50% solution of propylene glycol/water provides maximum protection to about -30°F.
4. Local codes may require **back flow preventer** or actual disconnect from city water supply.
5. When using antifreeze in a system with automatic fill, install a water meter to monitor water makeup. Glycol will leak before the water begins to leak, causing glycol level to drop. Added water will dilute the antifreeze, reducing the freeze protection level.



# 7a Start-up — preparation (continued)

## Fill the system with water

1. Close manual and automatic **air vents** and boiler drain cock.
2. **Fill to correct system pressure.** Correct pressure will vary with each application. Typical cold water fill pressure for a residential system is 12 psi.
3. **Purge air** from system:
  - a. Connect a hose to the purge valve (see **drain valves**, item 6, in suggested piping diagrams on pages 23 through 27, **Figure 18** through **Figure 23**). Route hose to an area where water can drain and be seen.
  - b. Close the boiler or system isolation valve between the purge valve and fill connection to the system.
  - c. Close zone isolation valves.
  - d. Open quick-fill valve on cold water makeup line.
  - e. Open purge valve.
  - f. One zone at a time, open the isolation valves. Allow water to run through the zone, pushing out the air. Run until no noticeable air flow is present. Close the zone isolation valves and proceed with the next zone. Follow this procedure until all zones are purged.
  - g. Close the quick-fill water valve and purge valve and remove the hose. Open all isolation valves. Watch that system pressure rises to correct cold-fill pressure.
  - h. After the system has operated for a while, eliminate any residual air by using the manual air vents located throughout the system.
  - i. If purge valves are not installed in system, open manual air vents in system one at a time, beginning with lowest floor. Close vent when water squirts out. Repeat with remaining vents.
4. Open **automatic air vent** (diaphragm-type or bladder-type expansion tank systems only) one turn.
5. Open other vents:
  - a. Starting on the lowest floor, open air vents one at a time until water squirts out.
  - b. Repeat with remaining vents.
6. Refill to correct pressure.

## Inspect system water piping

After filling the boiler and system with water, **inspect all piping** throughout the system for leaks. If found, repair immediately. Repeat this inspection after the boiler has been started and the system has heated up.



**Leaks must be repaired at once.** Failure to do so can damage the boiler, resulting in substantial property damage.



Do not use **petroleum-based cleaning or sealing compounds** in boiler system. Severe damage to boiler will occur, resulting in substantial property damage.

## Inspect base insulation



The boiler contains ceramic fiber and fiberglass materials. Use care when handling these materials per instructions on page 71 of this manual. Failure to comply could result in severe personal injury.



**Failure to replace** damaged insulation or reposition insulation can result in a fire hazard, causing severe personal injury, death or substantial property damage.

Check to make sure **base insulation is secure** against all four sides of the base. If insulation is damaged or displaced, **do not** operate boiler. Replace or reposition insulation.



# 7b Start-up — operate boiler

**WARNING**

**DO NOT** proceed with boiler operation unless boiler and system have been filled with water and all instructions and procedures of previous manual sections have been completed. Failure to do so could result in severe personal injury, death or substantial property damage. Before starting the boiler, do the following:

- Read manual **Section 9** and the **Operating instruction** procedure applicable for the gas valve supplied on the boiler (Section **9c**).
- Verify the boiler and system are **full of water**.
- Verify the **Start-up preparation** procedures of **Section 7** have been completed.

## Adjust boiler control settings

### BOILER OPERATING TEMPERATURE

With power turned on, control module receives a signal from the temperature/LWCO sensor and displays boiler temperature. The control knob labeled **BOILER TEMP** is used to adjust the operating temperature setpoint, turning clockwise to increase temperature setting and counterclockwise to decrease. When the knob is turned to adjust temperature the display will brighten to indicate adjustment mode. After temperature is set to desired value, display will dim after approximately 5 seconds to indicate measurement mode.

- **ADJUST BOILER OPERATING TEMPERATURE TO DESIRED SETPOINT.**

### BOILER ECONOMY SETTING

To comply with Department of Energy regulations, the control module circulates available hot water before turning on the boiler to attempt to satisfy a call for heat. While attempting to satisfy the heat demand, the control also monitors the boiler temperature changes via the temperature/LWCO sensor. It then determines whether the available hot water will satisfy the demand and adjusts the time delay to turn on the boiler until it determines that additional heat will be needed. The knob labeled **ECONOMY ADJUST** provides an adjustment between maximize (MAX) and minimize (MIN) time delay. The maximum (MAX) adjustment position should be used to maximize energy savings. Turning the knob counterclockwise decreases the delay time and should only be used in the event that the heated space becomes uncomfortable.

- **ADJUST ECONOMY TO DESIRED POSITION.**

## IMPORTANT

In accordance with Section 325 (f) (3) of the Energy Policy and Conservation Act, this boiler is equipped with a feature that saves energy by reducing the boiler water temperature as the heating load decreases. This feature is equipped with an override which is provided primarily to permit the use of an external energy management system that serves the same function.

**THIS OVERRIDE MUST NOT BE USED UNLESS AT LEAST ONE OF THE FOLLOWING CONDITIONS IS TRUE:**

- An external energy management system is installed that reduces the boiler water temperature as the heating load decreases.
- This boiler is part of a modular or multiple boiler system having a total input of 300,000 BTU/hr or greater.
- This boiler is equipped with a tankless coil.

**WARNING**

If you discover evidence of any gas leak, shut down the boiler at once. Find the leak source with bubble test and repair immediately. Do not start boiler again until corrected. Failure to comply could result in severe personal injury, death or substantial property damage.

**WARNING**

**Eliminate all system leaks.** Continual fresh makeup water will reduce boiler life. Minerals can build up in sections, reducing heat transfer, overheating cast iron, and causing section failure.

**WARNING**

**Glycol or antifreeze leaks** around the boiler may result in fire, causing severe personal injury, death or substantial property damage.

**DANGER**

Do not use **petroleum-based cleaning or sealing compounds** in boiler system. Severe damage to boiler will occur, resulting in substantial property damage.

# 7b Start-up — operate boiler (continued)

## Start the boiler

- Follow the **Operating instructions** from Section 9c to start the boiler.
- See Section 7c if boiler fails to start.

## Check system and boiler

1. **Check system piping for leaks.** If found, shut down boiler and repair immediately.
2. **Vent air from system** using manual vents. Air in the system will interfere with circulation and cause heat distribution problems and noise.
3. **Inspect vent system** thoroughly for signs of deterioration from corrosion, physical damage or sagging. In addition — Check for gas-tight seal at every connection and seam.

**Venting system must be sealed gas-tight** to prevent flue gas spillage and carbon monoxide emissions which will result in severe personal injury or death.

4. **Check around the boiler** for gas odor following the procedure of Section 7a of this manual.
5. **Verify operation** per Section 7b. Perform check-out procedure in Section 8, and fill in the **Installation and service certificate** on the same page.

## Check burner flames

View pilot and main flames through the inspection port in the base burner shield.

### Pilot burner flame (Figure 28)

#### *PROPER pilot flame characteristics*

1. Blue flame.
2. Inner cone engulfing pilot flame sensor.
3. Pilot flame sensor glowing cherry red.

#### *IMPROPER pilot flame characteristics*

1. Overfired — Large flame lifting or blowing past pilot flame sensor.
2. Underfired — Small flame. Inner cone not engulfing pilot flame sensor.
3. Lack of primary air — Yellow flame tip.
4. Incorrectly heated pilot flame sensor.

### Main burner flame (Figure 29)

#### *PROPER main burner flame characteristics*

1. Yellow-orange streaks may appear (caused by dust).

#### *IMPROPER main burner flame characteristics*

1. Overfired — Large flames.
2. Underfired — Small flames.
3. Lack of primary air — Yellow tipping on flames (sooting will occur).

**Figure 28** Typical pilot burner flame

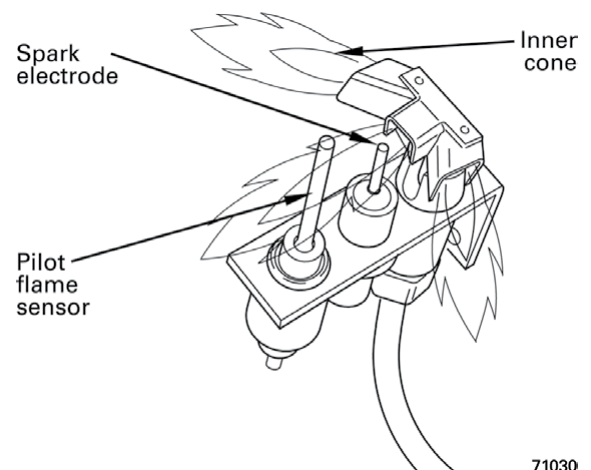

71030

**Figure 29** Typical main burner flame

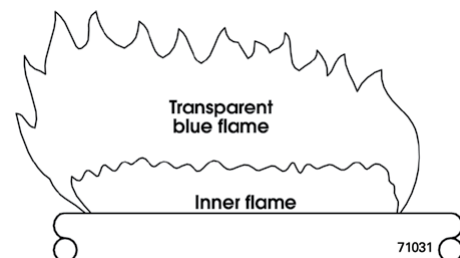

71031

# 7c Start-up — if boiler doesn't start . . .

## Check for:

1. Loose connections, blown fuse or service switch off?
2. High limit switch set below boiler water temperature?
3. Thermostat set below room temperature?
4. Gas not turned on at meter or boiler?
5. Incoming gas pressure less than:  
5" w.c. for natural gas? 11" w.c. for propane gas?
6. If none of the above corrects the problem, refer to **Troubleshooting**, section 11 of this manual.



# 8 Check-out procedure — checklist

- Boiler and heat distribution units filled with water?
- Automatic air vent, if used, open one full turn?
- Air purged from system?
- Air purged from gas piping? Piping checked for leaks?
- Correctly sized manifold orifices installed? Refer to **Table 2**, page 12, to check size and fuel type.

**⚠ DANGER** Correctly sized manifold orifices must be used. Failure to do so will cause severe personal injury, death or substantial property damage.

- Followed operating instructions on boiler or in manual Section 9 for proper start-up?
- Proper burner flame observed? Refer to **Check burner flame**, manual Section 7b.
- Test temperature limit — While burners are operating, turn Boiler Temp adjustment knob counterclockwise until display reading is below actual boiler water temperature. Burners should go off while circulator continues to operate. Turn Boiler Temp adjustment knob clockwise until display reading is above boiler water temperature and ignition sequence should resume.
- Test low water cut off — While burners are operating, press and hold “LWCO TEST” button on control. Burners should go off while circulator continues to operate and LWCO light should turn ON. Release “LWCO TEST” button and ignition sequence should resume.
- Test field-installed controls — If the boiler has an additional low water cutoff, additional high limit or other controls, test for operation as outlined by manufacturer. Burners should be operating and should go off when controls are tested. When controls are restored, burners should reignite.
- Test ignition system safety device:
  - a. Connect manometer to outlet side of gas valve.
  - b. Start boiler, allowing for normal start-up cycle to occur and main burners to ignite.
  - c. With main burners on, manually shut off gas supply at manual main shutoff gas valve. Burners should go off.
  - d. Open manual main shutoff gas valve. Manometer should confirm there is no gas flow.

- e. Pilot will relight, flame sensing element will sense pilot flame and main burners will reignite.
- Set limit control(s) to system temperature requirements. Adjust balancing valves and controls to provide design temperature to system.
- Set Economy mode.
- For multiple zones, adjust flow so it is about the same in each zone.
- Verify thermostat heat anticipator (if available) set properly? Refer to **Field wiring**, manual Section 6, page 31, **Thermostat(s)**.
- Cycle boiler with thermostat — Raise to highest setting and verify boiler goes through normal start-up cycle. Lower to lowest setting and verify boiler goes off.
- Cycle DHW Aquastat if used.
- Measure natural gas input:
  - a. Operate boiler 10 minutes.
  - b. Turn off other appliances.
  - c. At natural gas meter, measure time (in seconds) required to use one cubic foot of gas.
  - d. Calculate gas input:

$$\frac{3600 \times 1000}{\text{number of seconds from step c}} = \text{Btuh}$$

- e. Btuh calculated should approximate input rating on boiler rating label.
- Check manifold gas pressure by connecting manometer to downstream test tapping on main gas valve. Manifold pressure for natural gas should be 3.5" w.c. and for propane gas should be 10" w.c.
- Observe several operating cycles for proper operation.
- Set room thermostat to desired room temperature.
- Fill in Installation and service certificate below?
- Review all instructions shipped with this boiler with owner or maintenance person. Return instructions to envelope and give to owner or place in pocket inside front panel in boiler.

### Installation and service certificate

Boiler model \_\_\_\_\_ Series \_\_\_\_\_ Consumer Protection number \_\_\_\_\_ Date installed \_\_\_\_\_

Measured Btuh input \_\_\_\_\_

- Installation instructions have been followed.
- Check out sequence has been performed.
- Above information is certified to be correct.
- Information received and left with owner/maintenance person

Installer \_\_\_\_\_ (company) \_\_\_\_\_ (address) \_\_\_\_\_ (phone)

Installer's signature: \_\_\_\_\_



## 9 Department of Energy – Compliance

This boiler is equipped with a control system that automatically adjusts a time delay period to turn on the boiler during a call for heat. This is accomplished by circulating available hot water in the system while measuring water boiler water temperature changes. The control calculates a suitable delay based on temperature measurements and turns the boiler on only after it determines that the demand for heat cannot be satisfied with the available hot water.

Due to the wide variety of controls used in boiler installations, this control is also equipped with an adjustment for the calculated time delay period (ECONOMY ADJUST). In the MIN position, the time delay is zero and the IMPORTANT notice below must be observed:

### IMPORTANT

In accordance with Section 325 (f) (3) of the Energy Policy and Conservation Act, this boiler is equipped with a feature that saves energy by reducing the boiler water temperature as the heating load decreases. This feature is equipped with an override which is provided primarily to permit the use of an external energy management system that serves the same function.

THIS OVERRIDE MUST NOT BE USED UNLESS AT LEAST ONE OF THE FOLLOWING CONDITIONS IS TRUE:

- An external energy management system is installed that reduces the boiler water temperature as the heating load decreases.
- This boiler is part of a modular or multiple boiler system having a total input of 300,000 BTU/hr or greater.
- This boiler is equipped with a tankless coil.

## 9a Operation — sequence

1. **Read Operating instructions** on page 41. This information is also located on a label on the inside of the boiler jacket door panel.
2. **Raise** room thermostat to call for heat.
  - a. While attempting to satisfy the heat demand, the control module monitors the boiler temperature changes via the water temperature sensor and determines whether or not the available hot water will satisfy the demand, only running the circulator. If additional heat is needed, the sequence continues. When DHW (if used) calls for heat, sequence above is bypassed.
3. **Circulator energizes.** If limit circuit is closed, the inducer starts. After pressure switch proves proper airflow, control module initiates 10-second prepurge.
4. **Control module sparks** the pilot and opens pilot valve in main gas valve.
  - a. If pilot **does not** light within 15 seconds, pilot valve is closed and spark generator is turned off. Control module initiates a 15-second postpurge, then starts a new cycle.
  - b. If pilot does light and control module senses flame current, spark generator is turned off and main valve opens.
5. During main burner operation:
  - a. Control module monitors pilot flame current. If signal is lost, main valve closes, spark generator activates and sequence returns to step 4.
  - b. If power is interrupted, control system shuts off pilot and main gas valves and restarts at step 1 when power is restored.
6. In the event the **limit control shuts down the boiler** — The control module closes the pilot and main gas valves, but keeps the inducer operating for 15-second postpurge.



# 9a Operation — sequence (continued)

— The circulator continues to operate.

7. Lower room thermostat setting to stop call for heat. Thermostat is satisfied — Pilot and main gas valves are closed — Inducer operates for 15-second postpurge — Circulator is shut off.
8. Boiler is now in the off cycle.
9. Repeat steps 1 through 6 several times to verify operation.
10. Return the thermostat to normal setting.
11. Set thermostat heat anticipator setting as instructed in Figure 32, page 40.

**Figure 30** Control module sequence of operation — status light indications

STEPS (following step 7, cycle goes back to step 1.)	Call for Heat?	POWER	TSTAT CIRC	LIMIT	PURGE	FLAME	LWCO	Timing
<b>1. Standby</b> • Waiting for call for heat	<b>NO</b>							—
<b>2. Call for heat</b> • Circulator on	<b>YES</b>							—
<b>3. Limit circuit</b> • Limit controls closed • Rollout TFE contacts closed	<b>YES</b>							—
<b>4. Inducer</b> • Inducer turns on	<b>YES</b>							—
<b>5. Pressure circuit</b> • Pressure switch contacts closed • Prepurge for 10 seconds	<b>YES</b>							<b>35 sec</b>
<b>6. Flame proven *</b> • Gas valve open • Ignitor remains on • Boiler producing heat	<b>YES</b>							<b>15 sec</b>
<b>7. Limit cycle</b> • Limit circuit open • Gas valve closed	<b>YES</b>							—
<b>8. Flame outage *</b> • Flame out • Boiler recycles	<b>YES</b>							—
<b>9. Thermostat satisfied</b> • Circulator off	<b>NO</b>							<b>15 sec</b>
<b>10. Circulator exercise routine</b> • Circulator turns on for 30 seconds if boiler not operated for 30 days	<b>NO</b>							<b>30 sec</b>
<b>11. LWCO circuit</b> • LWCO circuit open	<b>YES/NO</b>							—

= ON      = OFF

\* See Section 9, Items 4b for controls response to failure to prove pilot flame.

Control will lockout under the following conditions:

- Line voltage polarity is reversed
- Stray voltage is sensed on thermostat line
- Flame is sensed when it shouldn't be there

Control will reset after these lockouts if any of the following occur:

- 1 hour waiting period
- Opening and closing of thermostat circuit for 2 to 20 seconds
- Removal of 120 VAC power for 2 to 20 seconds



# 9b Operation — wiring diagrams

Figure 31 Schematic wiring diagram

**CAUTION** *DO NOT connect directly from 3-wire zone valves to the T-T terminals on the boiler.* When using 3-wire zone valves, install an isolation relay. Connect the zone valve end switch wires to the isolation relay coil. Connect the isolation relay contact across the boiler T-T terminals. Failure to comply can result in damage to boiler components or cause unreliable operation, resulting in possible severe property damage.

**NOTICE**

- The control module is polarity-sensitive to the incoming 120 VAC power. If polarity is reversed, control will flash the **POWER** light when powered and will not cycle boiler.
- All contacts shown without power applied.
- Connector and status light locations/orientations may vary.

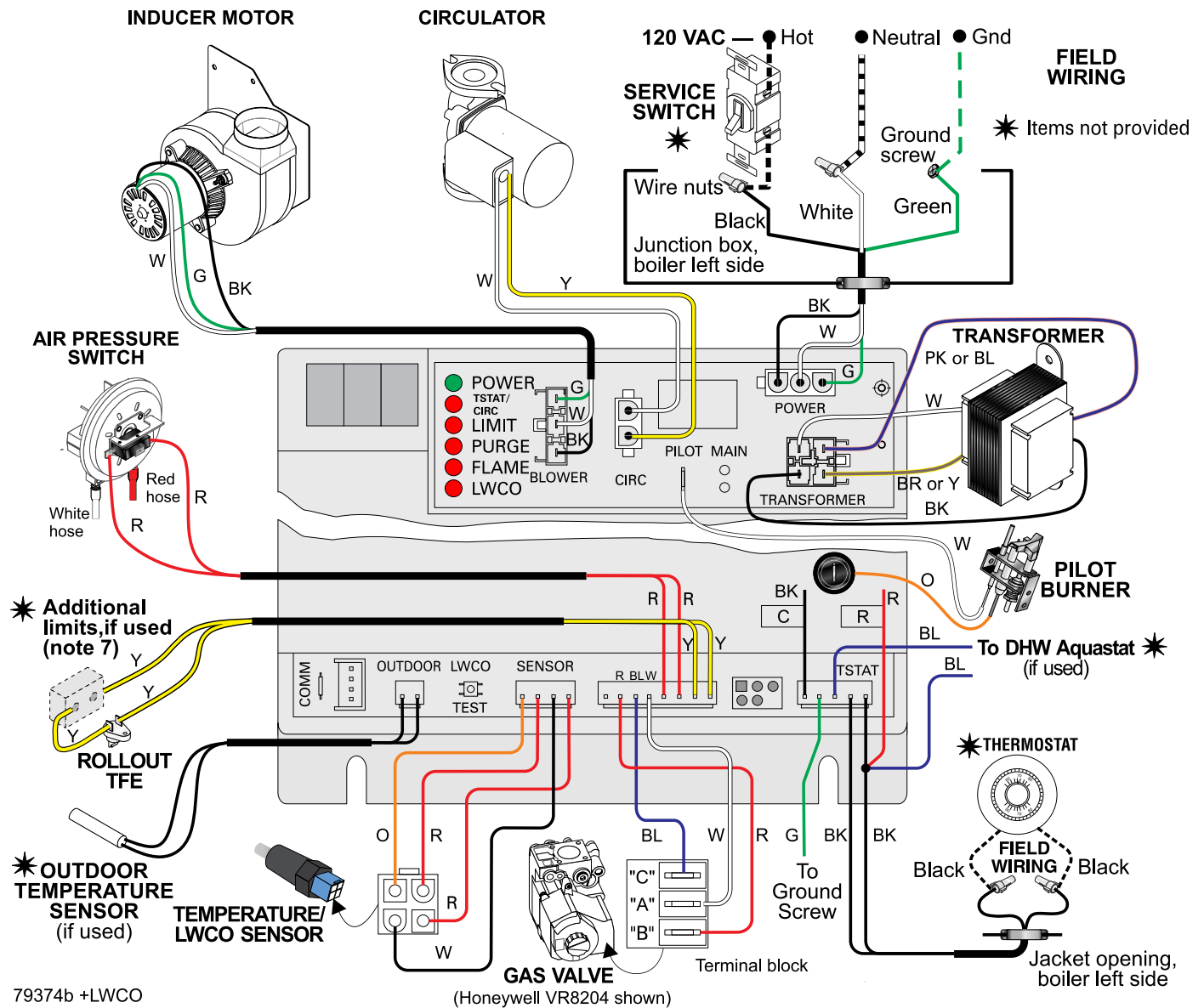

79374b +LWCO

(Honeywell VR8204 shown)



# 9b Operation — wiring diagrams (continued)

**Figure 32** Ladder wiring diagram

**WARNING** Electrical shock hazard — can cause severe injury or death. Disconnect power before installing or servicing.

Legend for ladder wiring diagram	
	120 VAC field wiring
	Low voltage field wiring
	120 VAC factory wiring
	Low voltage factory wiring
	High voltage spark ignition wiring
	Ground connectors

**Table G: Gas valve terminals and anticipator settings**

Gas valve	"A"	"B"	"C"	Anticipator amps
Honeywell VR8204	MV/PV	MV	PV	0.6
Honeywell VR8304	MV/PV	MV	PV	0.8
White-Rodgers 36E	2	1	3	0.64
White-Rodgers 36C	2-4 *	1	3	0.7

\* Terminals 2-4 are factory-jumpered on the White-Rodgers 36C gas valve.

- All wiring must be installed in accordance with:
  - U.S.A. — N.E.C. And any other national, state, or local code requirements.
  - Canada — C.S.A. C22.1 C.E.C. Part 1 and any other national, provincial, or local code requirements.
- Pilot lead wires are not field replaceable. Replace pilot assembly if necessary.
- If any of the original wire as supplied with the appliance must be replaced, use minimum 105 °C wire or equivalent. Exception — wires to a rollout TFE must be 200 °C or equivalent.
- Thermostat anticipator setting (single zone) — see Table G for anticipator setting, depending on which gas valve is installed in boiler.
- For multiple zoning, use either zone valves or circulators. Refer to the component manufacturer's instructions and this manual for application and wiring suggestions.
- Refer to control component instructions packed with the boiler for application information.
- Wire any additional limit controls (low water cut-off, additional high limit, etc.) in series with boiler rollout TFE and spill switch as shown.

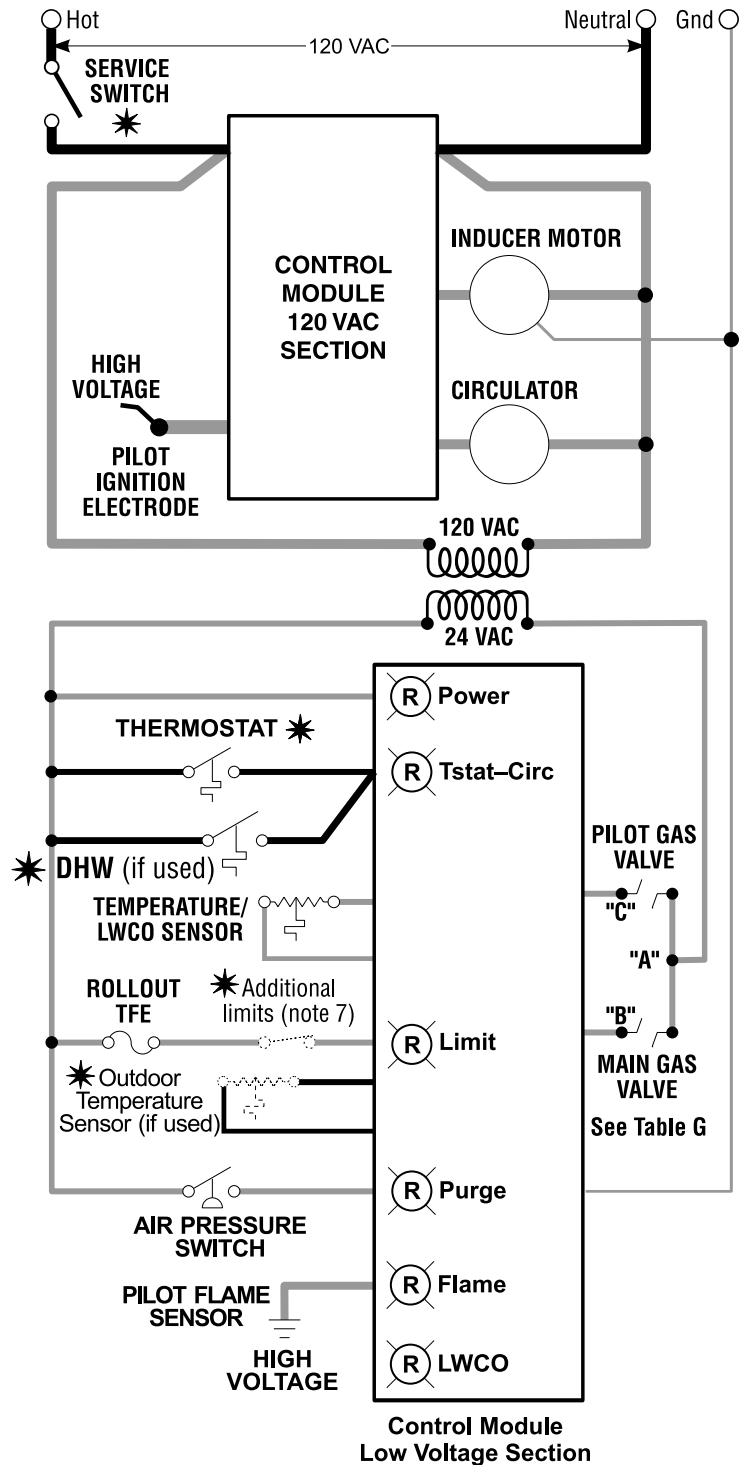

79374a +LWCO

# 9c Operating instructions CGi-25 thru -6

- Spark pilot • Natural or propane gas
- Gas valve: Honeywell VR8204/VR8304

## FOR YOUR SAFETY READ BEFORE OPERATING

**WARNING** If you do not follow these instructions exactly, a fire or explosion may result causing property damage, personal injury or loss of life.

- This appliance is equipped with an ignition device which automatically lights the pilot. Do not try to light the pilot by hand.
- BEFORE OPERATING**, smell all around the appliance area for gas. Be sure to smell next to the floor because some gas is heavier than air and will settle on the floor. See below.
- Use only your hand to turn the gas control knob. Never use tools. If the knob will not turn by hand, don't try to repair it, call a qualified service technician. Force or attempted repair may result in a fire or explosion.
- Do not use this appliance if any part has been under water. Immediately call a qualified service technician to inspect the appliance and to replace any part of the control system and any gas control, which has been under water.

### WHAT TO DO IF YOU SMELL GAS

- Do not try to light any appliance.
- Do not touch any electric switch; do not use any phone in your building.
- Immediately call your gas supplier from a neighbor's phone. Follow the gas supplier's instructions.
- If you cannot reach your gas supplier, call the fire department.

## OPERATING INSTRUCTIONS

- STOP!** Read the safety information above on this label.
- Set the thermostat to lowest setting.
- Turn off all electrical power to the appliance.
- Remove front panel.
- This appliance is equipped with an ignition device which automatically lights the pilot. Do not try to light the pilot by hand.
- Turn gas control knob clockwise ↻ to "OFF."
- Wait five (5) minutes to clear out any gas. Then smell for gas, including near the floor. If you smell gas, **STOP!** Follow "B" in the safety information above. If you don't smell gas, go to the next step.
- Turn gas control knob counterclockwise ↻ to "ON."
- Turn on all electric power to the appliance.
- Set thermostat to desired setting.
- If the appliance will not operate, follow the instructions "To Turn Off Gas To The Appliance" and call your service technician or gas supplier.
- Replace front panel.

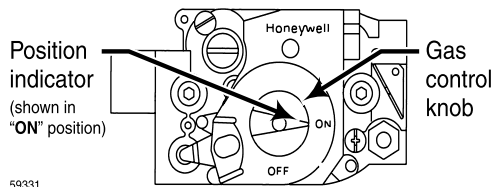

## TO TURN OFF GAS TO THE APPLIANCE

- Set the thermostat to lowest setting.
- Turn off all electric power to the appliance if service is to be performed.
- Remove front panel.
- Turn gas control knob clockwise ↻ to "OFF." Do not force.
- Replace front panel.

550-223-041(0415)

# 9c Operating instructions CGI-25 thru -6

- Spark pilot • Natural or propane gas
- Gas valve: White-Rodgers 36E

## FOR YOUR SAFETY READ BEFORE OPERATING



If you do not follow these instructions exactly, a fire or explosion may result causing property damage, personal injury or loss of life.

- A. This appliance is equipped with an ignition device which automatically lights the pilot. Do not try to light the pilot by hand.
- B. BEFORE OPERATING, smell all around the appliance area for gas. Be sure to smell next to the floor because some gas is heavier than air and will settle on the floor. See below.
- C. Use only your hand to turn the gas control knob. Never use tools. If the knob will not turn by hand, don't try to repair it, call a qualified service technician. Force or attempted repair may result in a fire or explosion.
- D. Do not use this appliance if any part has been under water. Immediately call a qualified service technician to inspect the appliance and to replace any part of the control system and any gas control, which has been under water.

### WHAT TO DO IF YOU SMELL GAS

- Do not try to light any appliance.
- Do not touch any electric switch; do not use any phone in your building.
- Immediately call your gas supplier from a neighbor's phone. Follow the gas supplier's instructions.
- If you cannot reach your gas supplier, call the fire department.

## OPERATING INSTRUCTIONS

1. STOP! Read the safety information above on this label.
2. Set the thermostat to lowest setting.
3. Turn off all electrical power to the appliance.
4. Remove front panel.
5. This appliance is equipped with an ignition device which automatically lights the pilot. Do not try to light the pilot by hand.
6. Turn gas control knob clockwise ↻ to "OFF."
7. Wait five (5) minutes to clear out any gas. Then smell for gas, including near the floor. If you smell gas, STOP! Follow "B" in the safety information above. If you don't smell gas, go to the next step.
8. Turn gas control knob counterclockwise ↺ to "ON."
9. Turn on all electric power to the appliance.
10. Set thermostat to desired setting.
11. If the appliance will not operate, follow the instructions "To Turn Off Gas To The Appliance" and call your service technician or gas supplier.
12. Replace front panel.

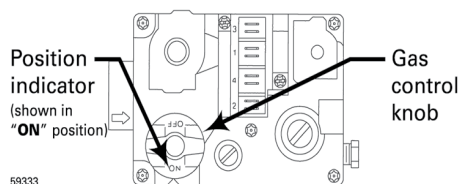

## TO TURN OFF GAS TO THE APPLIANCE

1. Set the thermostat to lowest setting.
2. Turn off all electric power to the appliance if service is to be performed.
3. Remove front panel.
4. Turn gas control knob clockwise ↻ to "OFF." Do not force.
5. Replace front panel.

550-223-042(0906)

# 9c Operating instructions CGi-25 thru -8

- Spark pilot • Natural or propane gas
- Gas valve: White-Rodgers 36C

## FOR YOUR SAFETY READ BEFORE OPERATING



If you do not follow these instructions exactly, a fire or explosion may result causing property damage, personal injury or loss of life.

- A. This appliance is equipped with an ignition device which automatically lights the pilot. Do not try to light the pilot by hand.
- B. BEFORE OPERATING, smell all around the appliance area for gas. Be sure to smell next to the floor because some gas is heavier than air and will settle on the floor. See below.
- C. Use only your hand to depress or turn the gas control knob. Never use tools. If the knob will not depress or turn by hand, don't try to repair it, call a qualified service technician. Force or attempted repair may result in a fire or explosion.
- D. Do not use this appliance if any part has been under water. Immediately call a qualified service technician to inspect the appliance and to replace any part of the control system and any gas control, which has been under water.

### WHAT TO DO IF YOU SMELL GAS

- Do not try to light any appliance.
- Do not touch any electric switch; do not use any phone in your building.
- Immediately call your gas supplier from a neighbor's phone. Follow the gas supplier's instructions.
- If you cannot reach your gas supplier, call the fire department.

## OPERATING INSTRUCTIONS

1. STOP! Read the safety information above on this label.
2. Set the thermostat to lowest setting.
3. Turn off all electrical power to the appliance.
4. Remove front panel.
5. This appliance is equipped with an ignition device which automatically lights the pilot. Do not try to light the pilot by hand.
6. Depress gas control knob slightly and turn clockwise ↻ to "OFF." Note: Knob cannot be turned to "OFF" unless knob is depressed slightly. Do not force.
7. Wait five (5) minutes to clear out any gas. Then smell for gas, including near the floor. If you smell gas, STOP! Follow "B" in the safety information above. If you don't smell gas, go to the next step.
8. Turn gas control knob counterclockwise ↺ to "ON."
9. Turn on all electric power to the appliance.
10. Set thermostat to desired setting.
11. If the appliance will not operate, follow the instructions "To Turn Off Gas To The Appliance" and call your service technician or gas supplier.
12. Replace front panel.

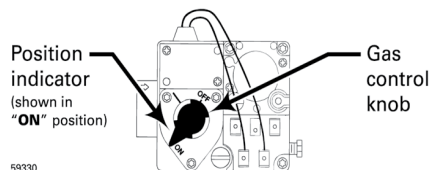

## TO TURN OFF GAS TO THE APPLIANCE

1. Set the thermostat to lowest setting.
2. Turn off all electric power to the appliance if service is to be performed.
3. Remove front panel.
4. Depress gas control knob slightly and turn clockwise ↻ to "OFF." Do not force.
5. Replace front panel.

550-223-043(0906)



# 10a Service and maintenance — schedule

**VERIFY PROPER OPERATION AFTER SERVICING**

**Table 8** Service and maintenance schedules

<b>Service technician</b> (see following pages for instructions)	<b>Owner maintenance</b> (see CGi User's Information Manual for instructions)
ANNUAL START-UP	<b>Inspect:</b>
	<ul style="list-style-type: none"> <li>• Reported problems</li> <li>• Boiler area</li> <li>• Air openings</li> <li>• Flue gas vent system (and air piping)</li> <li>• Pilot and main burner flames</li> <li>• Water piping</li> <li>• Boiler heating surfaces</li> <li>• Burners, base and inlet air box</li> <li>• Condensate drain system</li> </ul>
	<b>Service:</b>
	<ul style="list-style-type: none"> <li>• Inducer motor</li> <li>• Temperature/LWCO sensor</li> </ul>
	<b>Start-up:</b>
	<ul style="list-style-type: none"> <li>• Perform start-up per manual</li> </ul>
<b>Check/test:</b>	
<ul style="list-style-type: none"> <li>• Gas piping</li> <li>• Cold fill and operating pressures</li> <li>• Air vents and air elimination</li> <li>• Limit controls and cutoffs</li> <li>• Expansion tank</li> <li>• Boiler relief valve</li> </ul>	
<b>Review:</b>	
<ul style="list-style-type: none"> <li>• Review with owner</li> </ul>	
	<b>Daily</b>
	<ul style="list-style-type: none"> <li>• Check boiler area</li> <li>• Check air openings</li> <li>• Check boiler pressure temperature gauge</li> </ul>
	<b>Monthly</b>
	<ul style="list-style-type: none"> <li>• Check boiler interior piping</li> <li>• Check venting system</li> <li>• Check air vents</li> <li>• Check boiler relief valve</li> <li>• Check condensate drain system</li> <li>• Check automatic air vents (if used)</li> </ul>
	<b>Periodically</b>
	<ul style="list-style-type: none"> <li>• Test low water cutoff</li> </ul>
	<b>Every 6 months</b>
	<ul style="list-style-type: none"> <li>• Oil inducer motor</li> <li>• Operate relief valve</li> </ul>
	<b>End of season</b>
	<ul style="list-style-type: none"> <li>• Shut down procedure</li> </ul>



Follow the **Service and maintenance** procedures given throughout this manual and in component literature shipped with the boiler. Failure to perform the service and maintenance could result in damage to the boiler or system. Failure to follow the directions in this manual and component literature could result in severe personal injury, death or substantial property damage.



# 10b Service and maintenance — annual start-up

**⚠ WARNING**

The boiler should be **inspected and started annually**, at the beginning of the heating season, **only by a qualified service technician**. In addition, the maintenance and care of the boiler designated in **Table 8**, page 44, and explained on the following pages must be performed to assure maximum boiler efficiency and reliability. Failure to service and maintain the boiler and system could result in equipment failure.

**⚠ WARNING**

**Eliminate all system or boiler leaks.** Continual fresh makeup water will reduce boiler life. Minerals can build up in sections, reducing heat transfer, overheating cast iron, and causing section failure. Leaking water may also cause severe property damage.

**⚠ DANGER**

Do not use **petroleum-based cleaning or sealing compounds** in boiler system. Severe damage to boiler will occur, resulting in substantial property damage.

**⚠ WARNING**

Electrical shock hazard — **Turn off power to the boiler before any service operation** on the boiler except as noted otherwise in this instruction manual. Failure to turn off electrical power could result in electrical shock, causing severe personal injury or death.

## □ Inspect . . .

### Reported problems

Inspect any problems reported by owner and correct before proceeding.

### Boiler area

1. Verify that boiler area is free of any **combustible materials**, gasoline and other flammable vapors and liquids.
2. Verify that boiler area (and air intake) is free of any of the **contaminants** listed in **Table 1** on page 9 of this manual. If any of these are present in the boiler intake air vicinity, they must be removed. If they cannot be removed, isolate the boiler and provide outside combustion air. See national, provincial or local codes for further information.

### Air openings

1. Verify that combustion and ventilation air openings to the boiler room and/or building are open and **unobstructed**.
2. Verify that boiler vent discharge is **clean and free of obstructions**.

### Flue gas vent system

1. **Visually inspect entire flue gas venting system** for blockage, deterioration or leakage. Repair any joints that show signs of leakage in accordance with vent manufacturer's instructions.

**⚠ WARNING**

**Failure to inspect** for the above conditions and have them repaired can result in severe personal injury or death.

### Pilot and main burner flames

1. Visually inspect pilot burner and main burner flames as directed under **Start-up**, Section 7 of this manual.

### Water piping

1. Check the boiler interior piping and all system piping for signs of leaks.
2. Repair any leaks before proceeding.

### Boiler heating surfaces

1. Disconnect the vent pipe at the boiler inducer outlet connection after turning off power to the boiler.
2. Use a bright light to inspect the flue pipe interior and inducer interior.
3. Inspect the boiler vent outlet area and heating surfaces by looking through the opening.
4. If the vent pipe or inducer interior show evidence of soot, follow **Cleaning boiler heating surfaces** on page 48 to remove the flue collector and clean the boiler if necessary after close inspection of boiler heating surfaces. If there is evidence of rusty scale deposits, check the water piping and control system to make sure the boiler return water temperature is properly maintained (per this manual).
5. Reconnect vent to inducer outlet and replace all boiler components before returning to service.
6. Check inside and around boiler for evidence of any leaks from the boiler. If found, locate source of leaks and repair.



# 10b Service & maintenance – annual start-up (cont.)

## □ Inspect . . .

### Burners and base

**▲WARNING**

The boiler contains ceramic fiber and fiberglass materials. Use care when handling these materials per instructions on page 71 of this manual. Failure to comply could result in severe personal injury.

**▲WARNING**

If insulation is damaged or displaced, do not operate the boiler. Replace or reposition insulation as necessary. Failure to replace damaged insulation can result in a fire hazard, causing severe personal injury, death or substantial property damage.

1. After turning off power to the boiler, remove the base burner shield (**Figure 40**, item 4, page 64).
2. Inspect burners and all other components in the boiler base.
3. If burners must be cleaned see **Burner cleaning instructions** below.
4. Inspect the slotted jacket cooling openings in the bottom left and right of the base pan (**Figure 40**, item 7, page 64).
5. Inspect the base insulation. Pay attention to the **WARNING** on page 71 regarding working with insulation materials. Verify that the insulation is intact and secure against all four sides of the base.

### Burner cleaning instructions

**▲WARNING**

Airborne materials, such as fiberglass and dust, are present during construction and remodeling. These materials can be drawn in with the combustion air and obstruct burner ports, resulting in carbon monoxide production, a fire hazard, or building freeze damage. Read and follow the **WARNING** on page 9. Failure to inspect and clear gas burner ports could result in severe personal injury, death or substantial property damage.

1. Remove burner shield and the base pan air baffle. Next remove the pilot bracket assembly. Then remove the four screws securing the burner tray to the manifold and slide the burner tray out under the manifold.
2. Inspect each burner to insure that every port is completely open.
3. If any port is not completely clear, run a vacuum at the burner inlet while cleaning the burner ports with a wire brush. The vacuum will help to draw any airborne material out of the burner.

4. Reinstall components, starting with the burner tray, then the pilot bracket assembly, burner baffle, and air inlet top and front panels.
5. Follow the start-up procedure in the boiler manual.

### Condensate drain system

1. Inspect condensate drain fittings and tubing. Verify that condensate can flow freely to drain.

## □ Service . . .

### Inducer motor

1. With boiler power **off**, place a few drops of SAE 20 motor oil in each of the two oil cups.

**▲WARNING**

Use only **SAE 20 motor oil** to lubricate the inducer motor. Do not use universal household oils. Motor could be damaged, resulting in possible severe property damage.

### Oiled-bearing circulators

1. The circulator shipped with the CGi boiler is water-lubricated. No oiling is required.
2. Check other circulators in the system. Oil any circulators requiring oil, following circulator manufacturer's instructions. Over-oiling will damage the circulator.

### Temperature/LWCO sensor

1. The temperature/LWCO sensor may accumulate deposits on the probe surface. Annual inspection and cleaning of the probe will improve boiler performance. Disconnect power, unplug harness from sensor.
  - a. Drain boiler water to a level below the sensor.
  - b. Remove sensor from boiler.
  - c. Wipe any built up contaminants from probe and insulator surfaces.
  - d. Reinstall sensor into boiler using appropriate thread sealant. Do not overtighten.
  - e. Refill boiler.

## □ Start-up . . .

1. Perform all start-up procedures in Section 7 of this manual.
2. Verify **cold fill pressure** is correct and that fill system is working properly.
3. Verify **antifreeze level** (if used) is at the right concentration and that inhibitor level is correct.
4. **Check gas piping** per manual Sections 5 and 7a, verifying no indications of leakage and all piping and connections are in good condition.
5. Read the appropriate **Operating instructions** (Section 9c of this manual or on boiler label) applying to the boiler.
6. Start the boiler following the appropriate **Operating instructions** (Section 9c of this manual or on boiler label).

# 10b Service & maintenance – annual start-up (cont.)

## □ Check/test . . .

### Gas piping

1. Sniff near floor and around boiler area for any indication of a **gas leak**.
2. **Test gas piping using bubble test**, per Section 5 of this manual, if there is any indication of a leak.

### Cold fill and operating pressures

1. While the system is cold, note the **pressure reading** on the boiler pressure/temperature gauge. Verify that cold fill pressure is correct.
2. **Watch the pressure** as the boiler and system heat up to ensure pressure rise is normal. Too high a rise would indicate a waterlogged or undersized expansion tank.

### Air vents and air elimination

1. Inspect automatic air vents (if used). Also inspect air separators to ensure they are operational.
2. The cap must be unscrewed one turn to allow air to escape.
3. See **Figure 34**. If the air vent is leaking, remove cap **A** and briefly push valve **B** and then release to clean the valve seat.
4. Replace cap **A** by twisting all the way onto valve **B** and then unscrewing one turn.

**Figure 34** Automatic air vent, typical

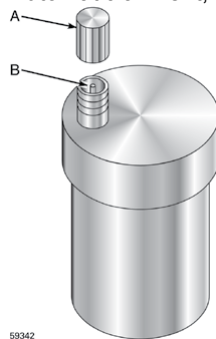

### Limit controls and cutoffs

1. Inspect and test the boiler limit control. Verify operation by turning control set point below boiler temperature. Boiler should cycle off. Return dial to original setting.
2. Inspect and test additional limit controls or low water cutoffs installed on system.

### Expansion tank

1. Expansion tanks provide space for water to move in an out as the heating system water expands due to temperature increase or contracts as the water cools. Tanks may be open, closed or diaphragm or bladder

type. See Section 4 of this manual for suggested best location of expansion tanks and air eliminators.

**Open-type** — located above highest radiator or baseboard unit, usually in the attic or closet. Has a gauge glass and overflow pipe to a drain.

**Closed-type** — welded gas tight and located above boiler. Tank is partially filled with water, leaving an air cushion for expansion.

- Make sure this type of tank is fitted with a **tank fitting**, such as the B & G **Tank-Trol** or Taco **Taco-Trol**. This fitting reduces gravity circulation of air-saturated tank water back to the system and prevents the air from bubbling up through the water as it returns from the system.
- **Do not use automatic air vents in systems with closed-type tanks.** The air will escape from the system instead of returning to the tank. Eventually, the tank will waterlog and no longer control pressurization. The boiler relief valve will weep frequently.

**Diaphragm- or bladder-type** — welded gas tight with a rubber membrane to separate the tank pressurizing air and the water. May be located at any point in the system, but most often found near the boiler.

- Systems with this type of expansion tank require at least one **automatic air vent**, preferably located on top of an air eliminator, as shown in examples in manual Section 4.

2. If relief valve has tended to weep frequently, the expansion tank may be waterlogged or undersized.

**Closed-type tank** — tank is most likely waterlogged. Install a tank fitting if not already installed. Then check fill level per fitting manufacturer's instructions. If fill level is correct, check tank size against manufacturer's instructions. Replace with a larger tank if necessary.

**Diaphragm- or bladder-type** — first, check tank size to be sure it is large enough for the system. If size is too small, add additional tank(s) as necessary to provide sufficient expansion. If tank size is large enough, remove tank from system and check charge pressure (usually 12 psig for residential applications). If tank won't hold pressure, membrane has been damaged. Replace tank.

# 10b Service & maintenance – annual start-up (cont.)

## ▲WARNING

Safety relief valves should be **reinspected AT LEAST ONCE EVERY THREE YEARS**, by a licensed plumbing contractor or authorized inspection agency, to ensure that the product has not been affected by corrosive water conditions and to ensure that the valve and discharge line have not been altered or tampered with illegally. Certain naturally occurring conditions may corrode the valve or its components over time, rendering the valve inoperative. Such conditions are not detectable unless the valve and its components are physically removed and inspected. This inspection must only be conducted by a plumbing contractor or authorized inspection agency — not by the owner. Failure to reinspect the boiler relief valve as directed could result in unsafe pressure buildup, which can result in severe personal injury, death or substantial property damage.

## ▲WARNING

Following installation, the **valve lever must be operated AT LEAST ONCE A YEAR** to ensure that waterways are clear. Certain naturally occurring mineral deposits may adhere to the valve, rendering it inoperative. When manually operating the lever, water will discharge and precautions must be taken to avoid contact with hot water and to avoid water damage. Before operating lever, check to see that a discharge line is connected to this valve directing the flow of hot water from the valve to a proper place of disposal otherwise severe personal injury may result. **If no water flows, valve is inoperative.** Shut down boiler until a new relief valve has been installed.

### Boiler relief valve

1. Inspect the relief valve and lift the lever to verify flow as in the following warnings, excerpted from a relief valve manufacturer's warning label. Before operating any relief valve, ensure that it is piped with its discharge in a safe area to avoid severe scald potential. Read manual Section 4 before proceeding further.
2. After following the above warning directions, if the relief valve weeps or will not seat properly, replace the relief valve. Ensure that the reason for relief valve weeping is the valve and not over-pressurization of the system due to expansion tank waterlogging or under sizing.

**Figure 35** Relief valve, typical

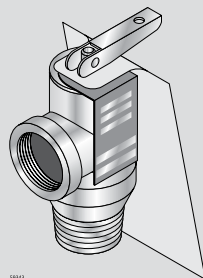

## □ Review with owner

1. Review the **User's Information Manual** with the owner.
2. Emphasize the need to perform the maintenance schedule specified in the **User's Information Manual** (and in this manual as well).
3. Remind the owner of the need to call in a licensed contractor should the boiler or system exhibit any unusual behavior.
4. Remind the owner to follow the proper shutdown procedure and to schedule an annual start-up at the beginning of the next heating season.

## □ Cleaning boiler heating surfaces

### ▲WARNING

The boiler contains ceramic fiber and fiberglass materials. Use care when handling these materials per instructions on page 71 of this manual. Failure to comply could result in severe personal injury.

1. Shut down boiler:
  - Follow "**To Turn Off Gas to Appliance**" instructions on boiler and **Operating instructions**.
  - Do not drain boiler unless it will be exposed to freezing temperatures. If using antifreeze in system, do not drain.
2. Follow shutdown procedure.
3. Remove venting system connection to boiler.
4. Remove top jacket panel. Turn back insulation.
5. Remove collector box/transition assembly. Clean sealant from assembly and sections.
6. Remove radiation plates hanging between sections.
7. Remove burners from base. Brush and vacuum burners to remove all dust and lint. Verify that all burner ports are free of debris.
8. Place newspapers in base of boiler to collect soot.
9. Clean between sections with wire flue brush.
10. Remove newspaper and soot. Vacuum or brush base and surrounding area.
11. Reinstall radiation plates.
12. Replace collector box/transition assembly. Seal with sealant. Obtain gas-tight seal to prevent flue gas spillage and carbon monoxide emissions, resulting in severe personal injury or death.
13. Replace insulation and jacket top panel.
14. Start up boiler following Section 7, pages 32-35 of this manual and the boiler **Operating instructions**. Excessive sooting indicates improper gas combustion. If found check for proper combustion and make any necessary adjustments.

# 11a Troubleshooting — procedure

## CAUTION

Label all wires prior to disconnection when servicing controls. Wiring errors can cause improper and dangerous operation.

## WARNING

Never jumper (bypass) rollout thermal fuse element or any other device except for momentary testing as outlined in **Troubleshooting Charts**. Severe personal injury, death or substantial property damage can result.

### Before troubleshooting:

- Have the following items:
  - Voltmeter that can check 120VAC and 24VAC.
  - Microammeter with a minimum scale range of 0-25.
  - Continuity checker.
  - U-tube manometer.
- Check for 120VAC (minimum 102VAC to maximum 132VAC) to boiler.
- Make sure thermostat is calling for heat and contacts (including appropriate zone controls) are closed. Check for 24VAC between thermostat wire nuts and ground.

### Check the following:

- Wire connectors to control module are securely plugged in at module and originating control.
- Air pressure switch hoses are properly and securely plugged in and are not damaged.
- Gas pressures:
  - With boiler off — 13" w.c. maximum natural or propane gas pressure upstream of gas valve.
  - With boiler on:
    - 5" w.c. minimum natural gas pressure or 11" w.c. propane gas pressure upstream of gas valve.
    - 3 1/2" w.c. minimum natural gas pressure or 10" w.c. propane gas pressure downstream of gas valve — Can be adjusted by regulator on gas valve.
- Verify gas manifold pressure (downstream of gas valve):
  - Natural gas:  
Manifold pressure, high fire: 3.50" w.c.
  - Propane gas:  
Manifold pressure, high fire: 10.0" w.c.
  - If necessary, adjust gas pressure on the gas valve as shown below. After adjustments, refer to page 35 to check the flame.

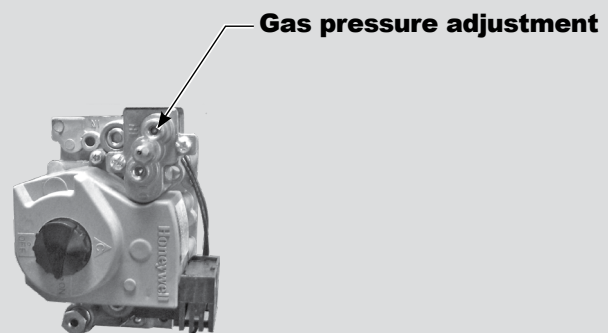

# 11b Troubleshooting — components

## Air pressure switch

### NOTICE

Make sure boiler water temperature is 100 °F or cooler before starting procedure to obtain appropriate readings.

### NOTICE

The boiler will not operate correctly unless pressure switch hoses are correctly located. The red hose connects from the right side (negative) hose barb to the flue collector. The white hose connects from the left side (positive) hose barb of the switch to the connector box (between flue collector and inducer) as shown in **Figure 36**, page 50.

### Check pressure switch setting

- See **Figure 36**, page 50, and **Table 9**.
- Remove both air pressure switch hoses from air pressure switch.
- Install tees and tubing as shown in **Figure 36**, page 50, to inclined manometer.
- Turn off gas valve and set thermostat to call for heat. Inducer will run but burners will not ignite.
- Check for 24 VAC between both air pressure switch terminals.



# 11a Troubleshooting — components (continued)

## Troubleshooting air pressure reading

- If manometer reading is lower than the setpoint of the switch (see **Table 9**) — check for possible causes:
  - blockage in hoses
  - obstruction in inducer housing outlet
  - loose inducer wheel on motor shaft
  - inducer motor not in proper rpm
  - inducer back plate not sealed properly
  - blockage in block assembly
- If manometer reading is above the setpoint of the switch (see **Table 9**), but there is not 24 VAC between both air pressure switch terminals — replace air pressure switch.

## Return to normal operation

When pressure reading is correct and air pressure switch is operating properly — remove tees and reinstall hoses to air pressure switch.

**Table 9** Pressure switch setpoint (for elevations above 2,000 ft., contact your local Weil-McLain Technical Service office for details.)

Boiler model number	Inches W.C.
CGi-25	2.10
CGi-3	2.10
CGi-4	1.40
CGi-5	1.65
CGi-6	1.20
CGi-7	1.35
CGi-8	1.45

**Figure 36** Manometer connections

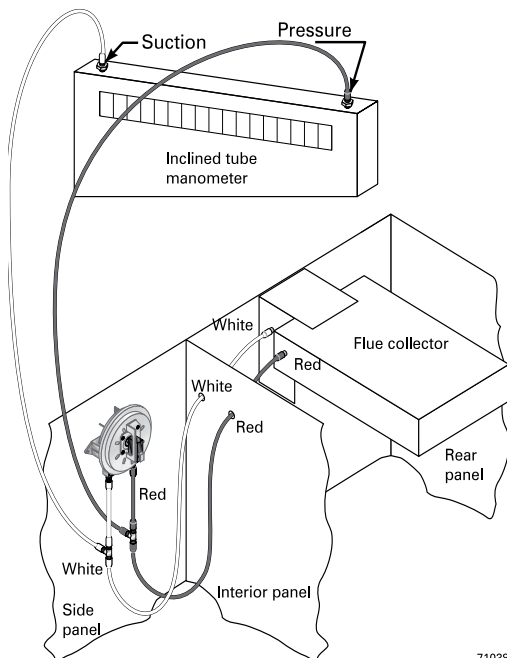

71038

## Temperature/LWCO sensor

- The boiler temperature/LWCO sensor is a resistance-type device.
- The **Table 10**, below shows the correct value for the sensor at various temperatures.
- Use the resistance values at 32°F, 60°F, 70°F and 212°F to measure the sensor resistance at known temperatures (ice point, room temperature and sea level boiling point). For ice point and boiling point, insert the sensor in water at that temperature. Use an ohmmeter to read resistance value between thermistor # and thermistor common. See Figure 38, page 52, for sensor plug details.

**Table 10** Temperature/LWCO sensor resistance values

Sensor resistance values					
Temp. (°F)	Sensor ohms		Temp. (°F)	Sensor ohms	
	Min.	Max.		Min.	Max.
<b>32</b>	34265	37871	<b>120</b>	4517	4992
<b>40</b>	27834	30764	<b>130</b>	3698	4088
<b>50</b>	21630	23907	<b>140</b>	3043	3364
<b>60</b>	16944	18727	<b>150</b>	2517	2782
<b>70</b>	13372	14780	<b>160</b>	2091	2311
<b>80</b>	10629	11747	<b>170</b>	1744	1928
<b>90</b>	8504	9399	<b>180</b>	1461	1615
<b>100</b>	6847	7568	<b>190</b>	1229	1359
<b>110</b>	5545	6129	<b>200</b>	1038	1147

# 11b Troubleshooting — components (continued)

## NOTICE

The information on this page and pages 52 through 60 apply only to spark-ignited pilot CGi boilers. These boilers are equipped with an ignition control module that has indicator lights to show control status. Charts 1 through 8, pages 53-60, help you identify problems based on indicator light conditions.

Figure 37 Control module



## Control module

### WARNING

Solder or water splatter between plugs and circuit board can cause improper operation of control module. Place a shield over the boiler internal controls and components during installation. Failure to comply could result in severe personal injury, death or substantial property damage.

## NOTICE

Make sure **ground wiring** is installed per wiring diagram. Good grounding is extremely important for proper operation.

## Control indicator lights — LOCKOUT modes

See Charts 1 through 8 in this section for detailed troubleshooting procedures.

## Control indicator lights — HARD LOCKOUT Summary (Flashing LED's)

MAY remove 120VAC power for more than 2 seconds to clear lockout OR ignition control will automatically restart sequence of operation after 1 hour waiting period after fault condition is cleared.

INDICATOR LIGHT	CONDITION
POWER Flashes once per second	120 VAC connection to boiler reversed or there is insufficient earth ground.
Flash code 2*	Internal fault, microprocessor or memory.
Flash code 3*	Internal fault, LWCO circuit.
Flash code 4*	Unused.
Flash code 5*	Internal fault, water thermistors disagree.
Flash code 6* Flashes once per second	Internal fault, gas valve circuit.
* Flash code pattern: POWER LED flashes 2, 3, etc. times rapidly followed by 2 seconds off, then repeats.	
ALL LED'S FLASHING	Failure to establish pilot flame after 4 attempts.
SOLID LWCO LED	Low water condition occurred.

## SOFT LOCKOUT Summary (Flashing LED's)

MAY remove 120VAC power for more than 2 seconds, cycle thermostat for between 2 and 20 seconds, OR ignition control will automatically restart sequence of operation after 1 hour waiting period.

INDICATOR LIGHT	CONDITION
POWER + TSTAT/CIRC	High voltage detected on TSTAT circuit.
POWER + PURGE	Pressure Switch stuck open or closed.
POWER + FLAME	Flame sensed without call for heat or out of sequence during ignition trial.
CAUTION Summary (Flashing LED's)	
INDICATOR LIGHT	CONDITION
PURGE	Pressure switch opened after it had been proven closed.
LIMIT	Fault detected in temperature sensing hardware.
FLAME	Flame loss or flame not sensed during trial for ignition.
LWCO	LWCO circuit approaching lockout state. Sensor requires maintenance. LWCO LED will flash 3 times when maintenance is required.

## Troubleshooting the control module

See Figure 38, for location of harness plug receptacles and plugs on the control module.



# 11b Troubleshooting — components (continued)

**Figure 38** Control module connections

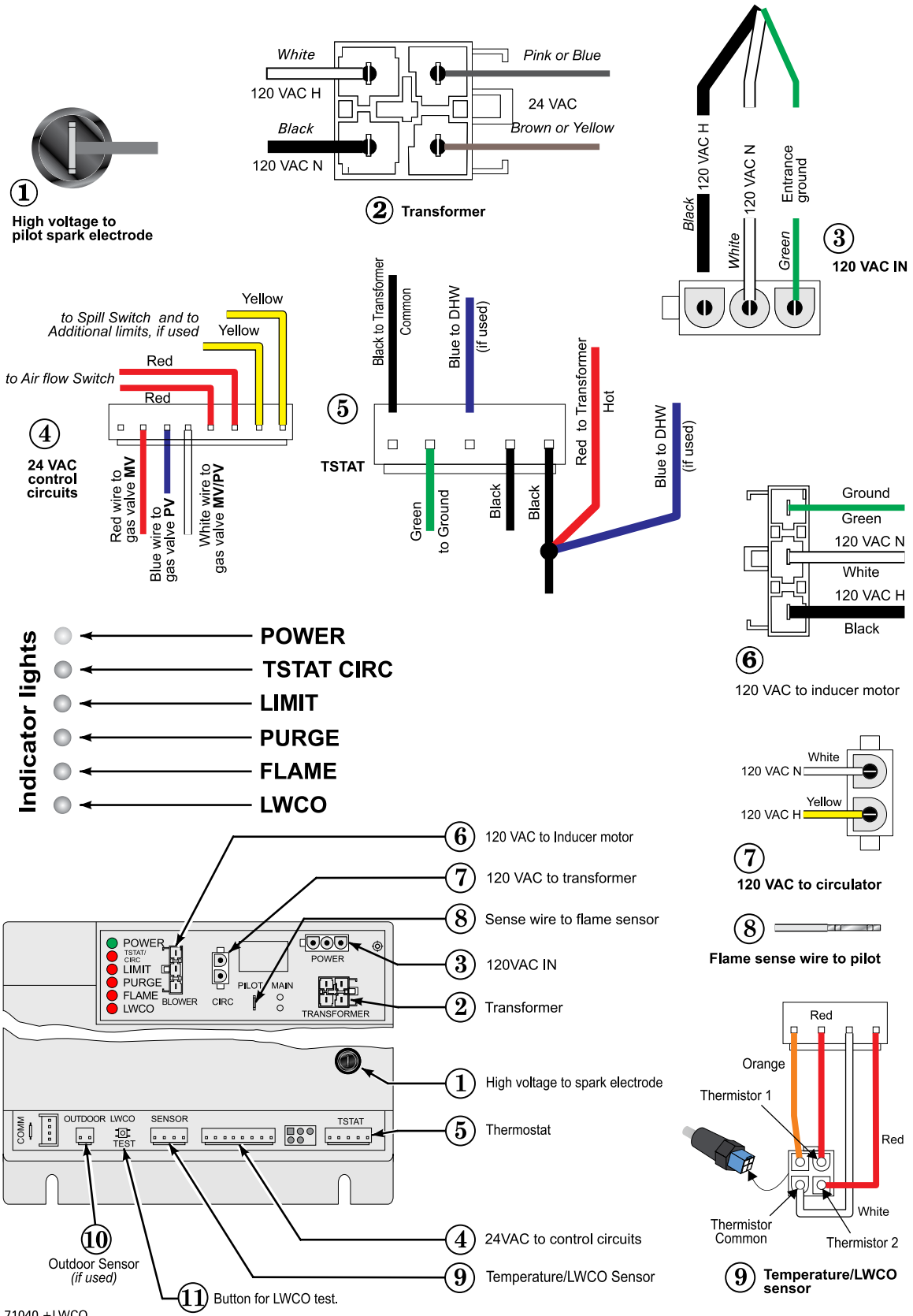

71040 +LWCO



# 11c Troubleshooting — control module lights

**CHART 1 — Troubleshooting POWER light status**

— Usually indicates reversed 120 VAC polarity if POWER light flashes by itself —

**⚠ WARNING Electrical shock hazard** — Wherever you see **▲ TURN OFF POWER ▲**, follow the instructions. Failure to follow instructions could result in severe personal injury, death or substantial property damage.

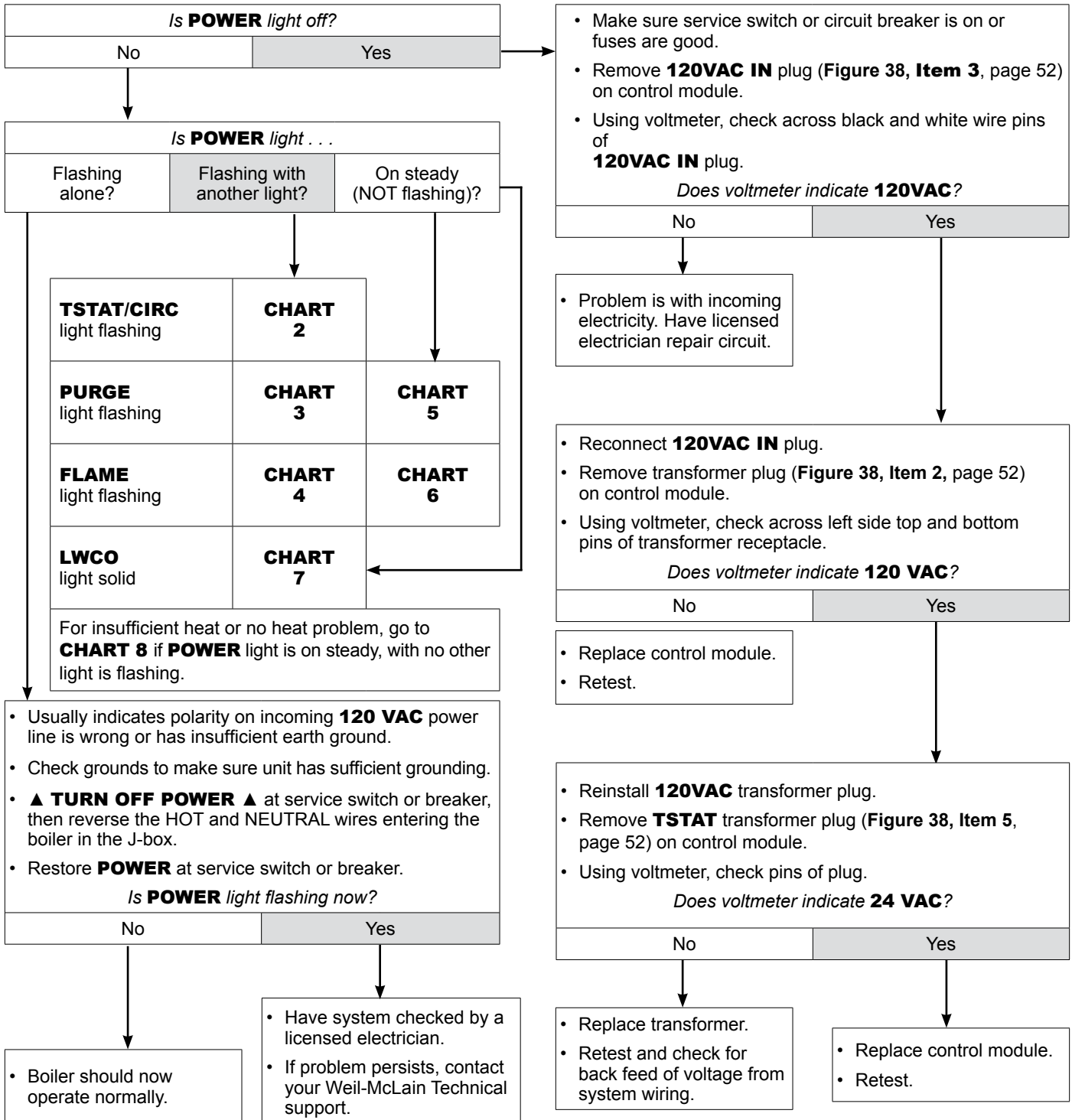



# 11c Troubleshooting — control module lights (cont.)

## CHART 2 — TSTAT CIRC & POWER light flashing

— Usually indicates 48 VAC on thermostat circuit (stray voltage) —

**⚠ WARNING Electrical shock hazard** — Wherever you see **▲ TURN OFF POWER ▲**, follow the instructions. Failure to follow instructions could result in severe personal injury, death or substantial property damage.

- Disconnect the two external wires connected to the boiler thermostat leads (two black low voltage leads in J-box).
  - Connect a voltmeter across these two incoming wires. Close each thermostat, zone valve and relay in the external circuit one at a time and check the voltmeter reading across the wires.
  - There should NEVER be a voltage reading.
  - If a voltage does occur under any condition, check and correct the external wiring. (This is a common problem when using 3-wire zone valves.)
  - Once the external thermostat circuit wiring is checked and corrected if necessary, reconnect the external thermostat circuit wires to the boiler thermostat wires and allow the boiler to cycle.
- Did you find and correct a voltage across the two external thermostat circuit wires?*

Yes	No
-----	----



- Leave external boiler thermostat connection wires disconnected from boiler.
- Troubleshoot the external thermostat circuit until you find the source of the stray voltage. (Pay close attention to the wiring connections to 3-wire zone valves.)
- Correct the problem and repeat the voltmeter test above, verifying there is no longer a voltage reading under any condition in the external thermostat circuit.
- An isolating relay may be required.

- If no voltage is found under any condition of the external thermostat circuit, connect the two boiler thermostat connection leads together (or jumper the boiler aquastat T-T terminals).
  - Turn off power to the boiler for 1 minute.
  - Turn on power and allow boiler to cycle.
- Does the TSTAT and POWER lights still flash?*
- |    |     |
|----|-----|
| No | Yes |
|----|-----|

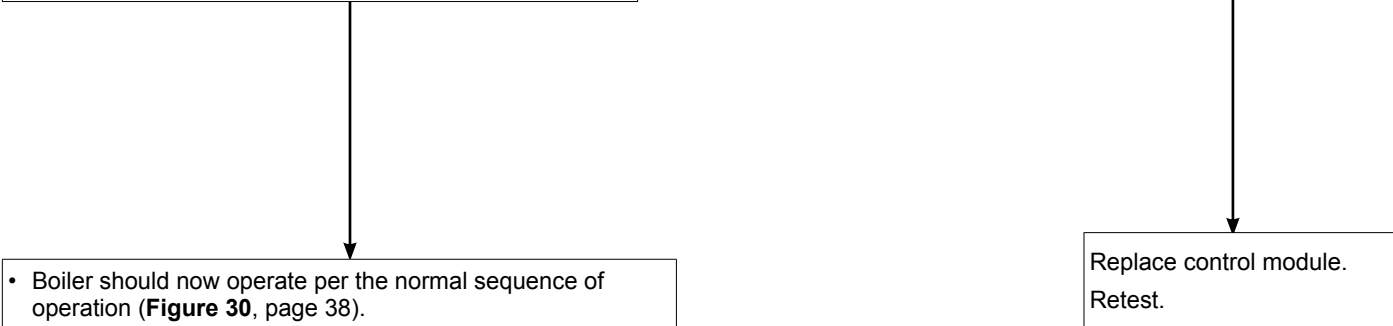

• Boiler should now operate per the normal sequence of operation (**Figure 30**, page 38).

Replace control module.  
Retest.



# 11c Troubleshooting — control module lights (cont.)

## CHART 3 — PURGE & POWER light flashing

— Usually indicates pressure switch stuck closed or failed to make within 5 minutes —

**⚠ WARNING Electrical shock hazard** — Wherever you see **▲ TURN OFF POWER ▲**, follow the instructions. Failure to follow instructions could result in severe personal injury, death or substantial property damage.

- Reset boiler control by turning off power at service switch or turning down thermostat for at least 45 seconds.
- Thermostat should call for heat and appropriate zone valves open.

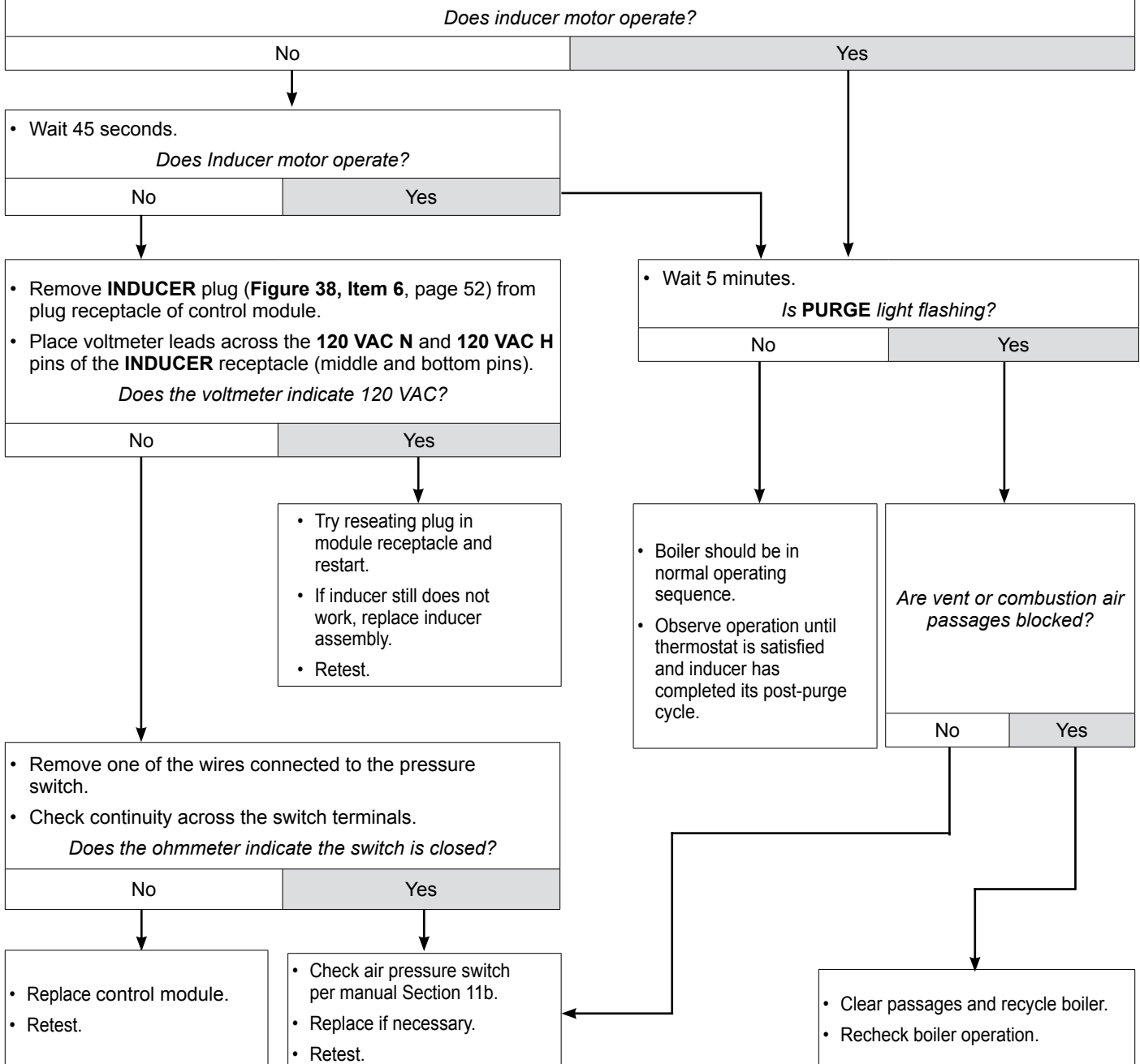



# 11c Troubleshooting — control module lights (cont.)

## CHART 4 — FLAME & POWER light flashing

— Usually indicates flame sensed when it shouldn't be there —

**⚠ WARNING** **Electrical shock hazard** — Wherever you see **▲ TURN OFF POWER ▲**, follow the instructions. Failure to follow instructions could result in severe personal injury, death or substantial property damage.

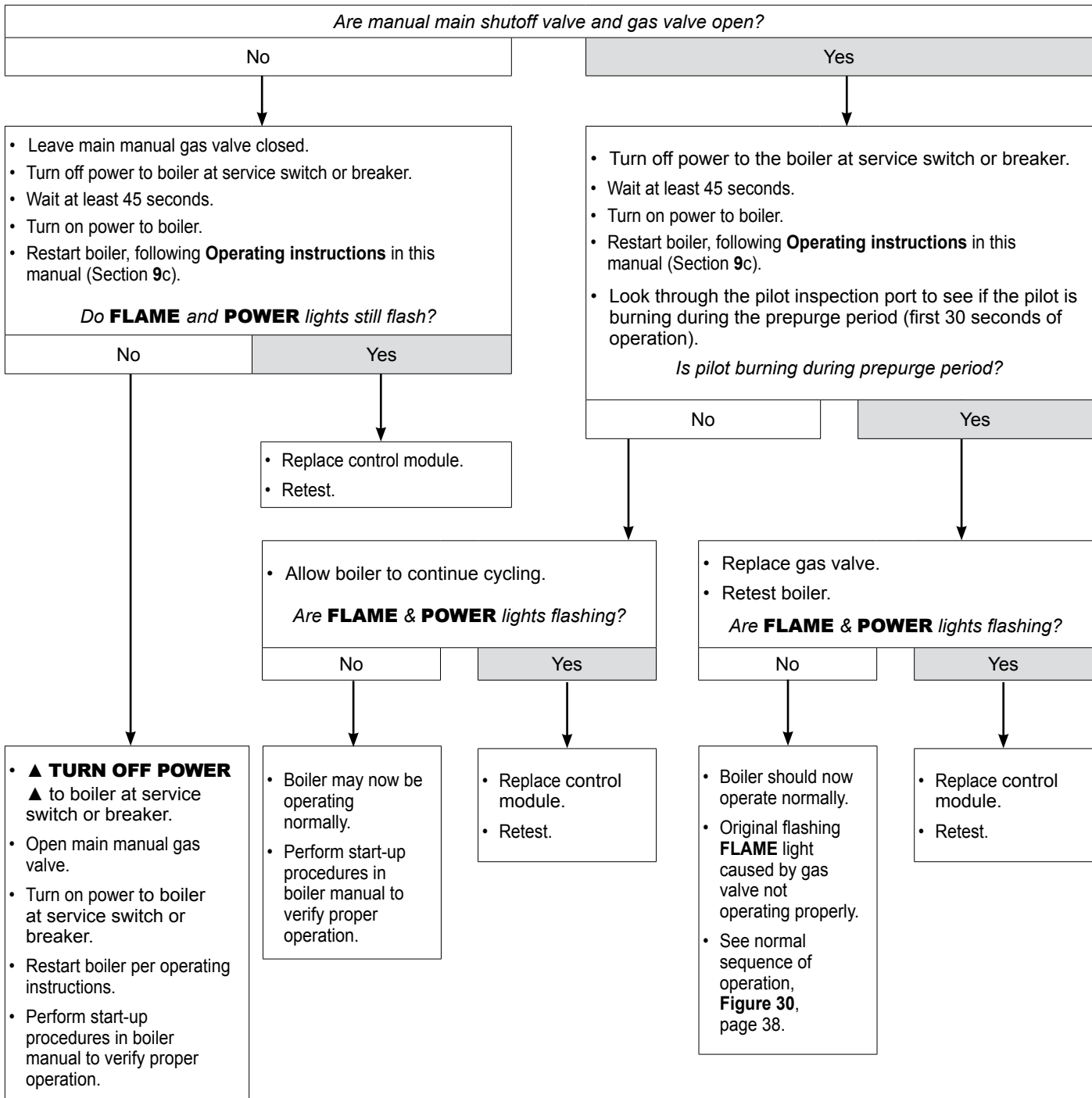



# 11c Troubleshooting — control module lights (cont.)

## CHART 5 — PURGE light flashing and POWER light on steady

— Usually indicates pressure switch opened during run cycle —  
 — May also be caused by wind gusts in excess of 31 mph for non-direct vent sidewall-vented boilers —

**⚠ WARNING Electrical shock hazard** — Wherever you see **▲ TURN OFF POWER ▲**, follow the instructions. Failure to follow instructions could result in severe personal injury, death or substantial property damage.

- Reset boiler control by turning off power at service switch or turning down thermostat for at least 45 seconds.
- Thermostat should call for heat and appropriate zone valves open.

*Does inducer motor operate?*

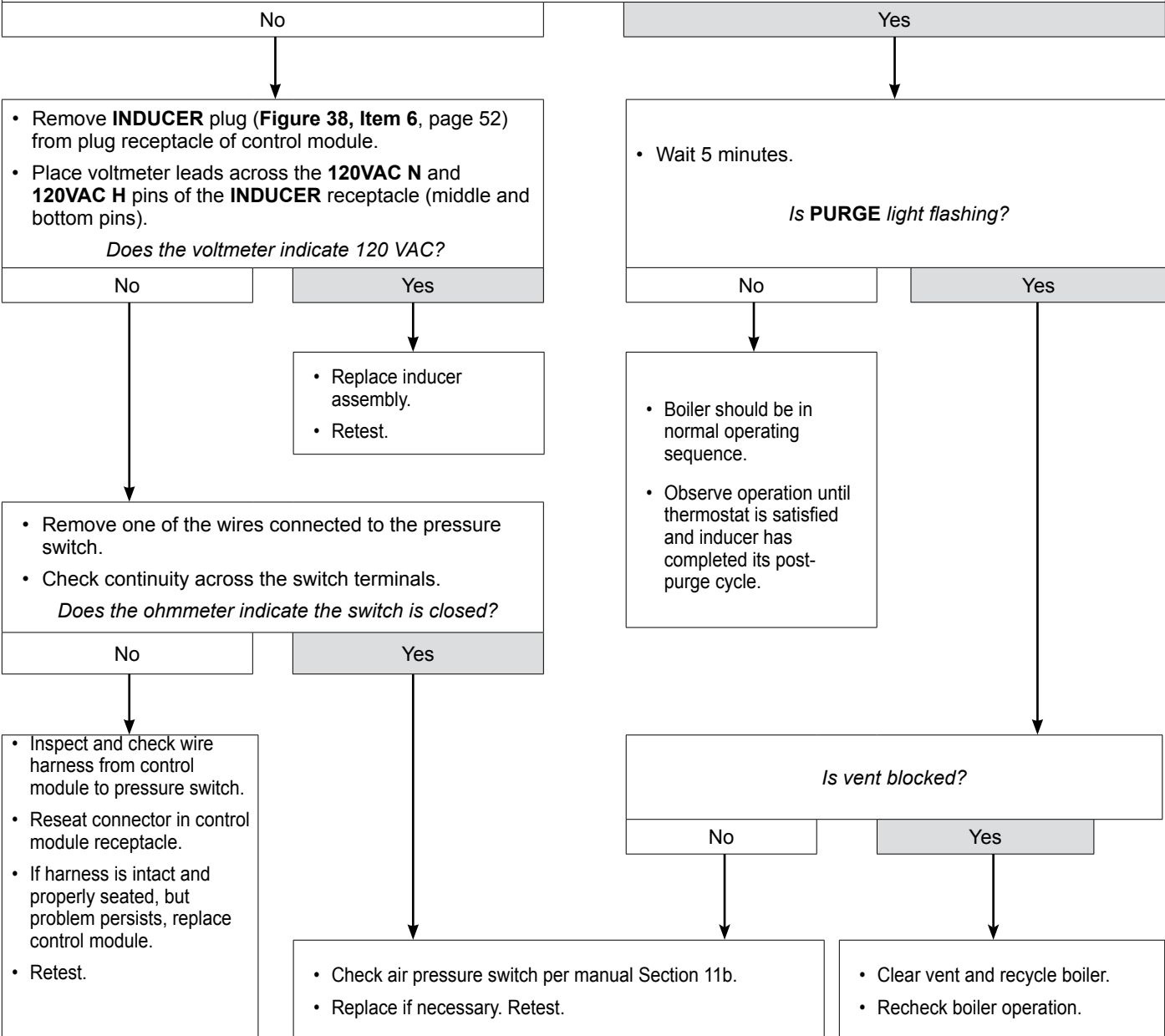



# 11c Troubleshooting — control module lights (cont.)

**CHART 6 — FLAME light flashing and Power light on steady**  
**Also — Troubleshooting failure to establish main flame.**

**⚠ WARNING Electrical shock hazard** — Wherever you see **▲ TURN OFF POWER ▲**, follow the instructions. Failure to follow instructions could result in severe personal injury, death or substantial property damage.

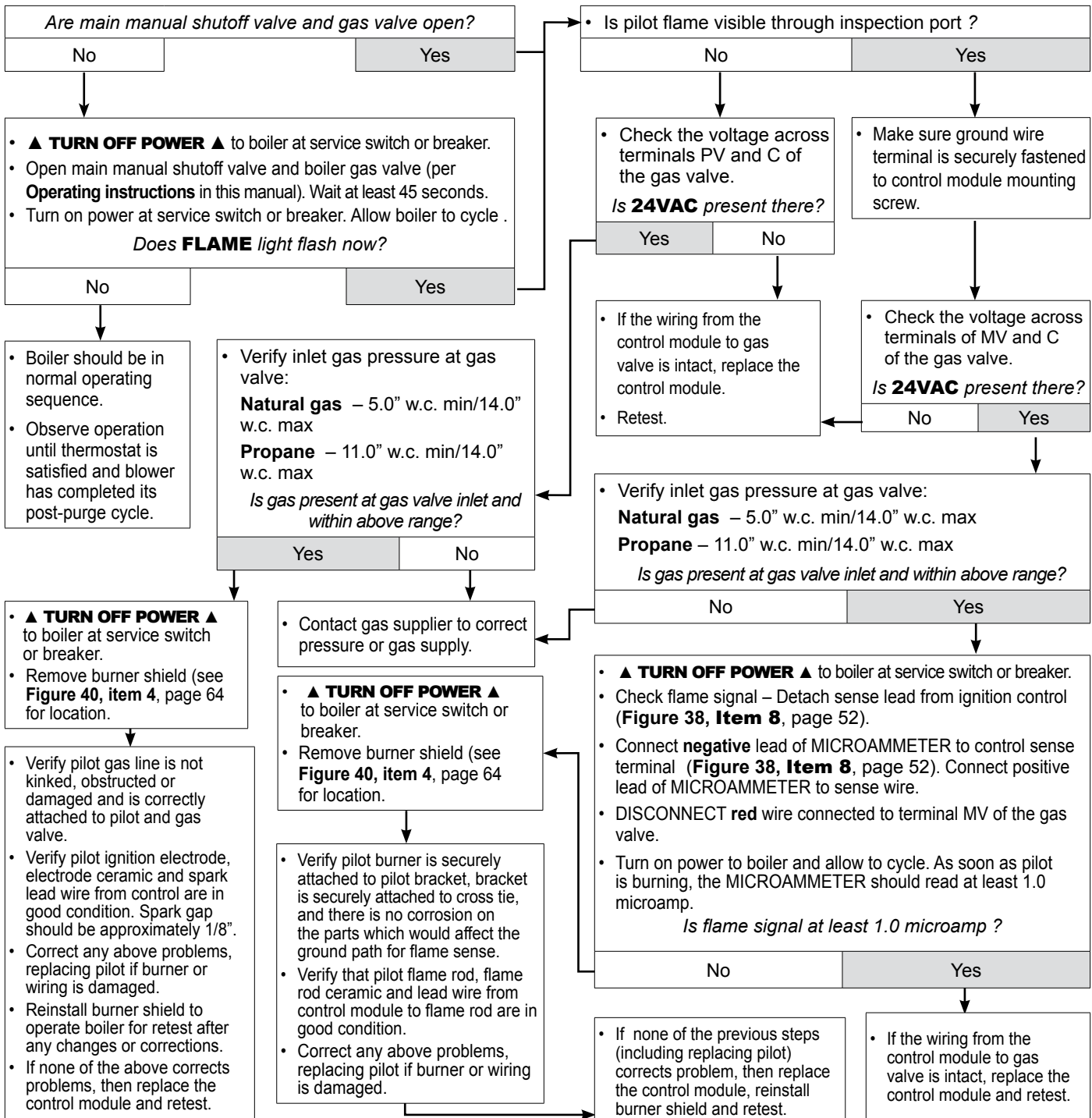



# 11c Troubleshooting — control module lights (cont.)

## CHART 7 — Troubleshooting LWCO and POWER light Solid and/or “LCO” shown on display

**⚠️ WARNING Electrical shock hazard** — Wherever you see **▲ TURN OFF POWER ▲**, follow the instructions. Failure to follow instructions could result in severe personal injury, death or substantial property damage.

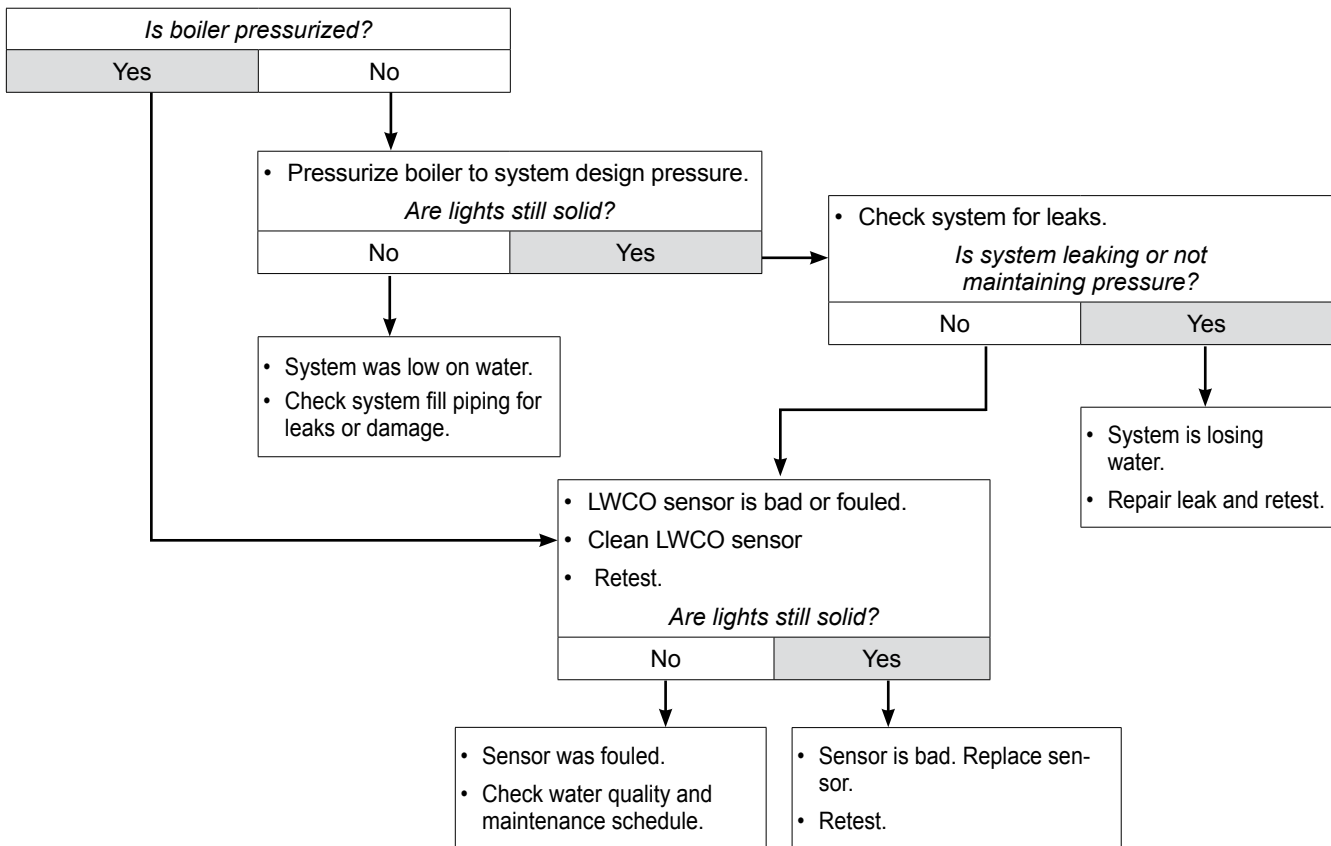



# 11c Troubleshooting — control module lights (cont.)

**CHART 8 — Insufficient heat or no heat to system (POWER light on steady)**

**⚠ WARNING Electrical shock hazard** — Wherever you see **▲ TURN OFF POWER ▲**, follow the instructions. Failure to follow instructions could result in severe personal injury, death or substantial property damage.

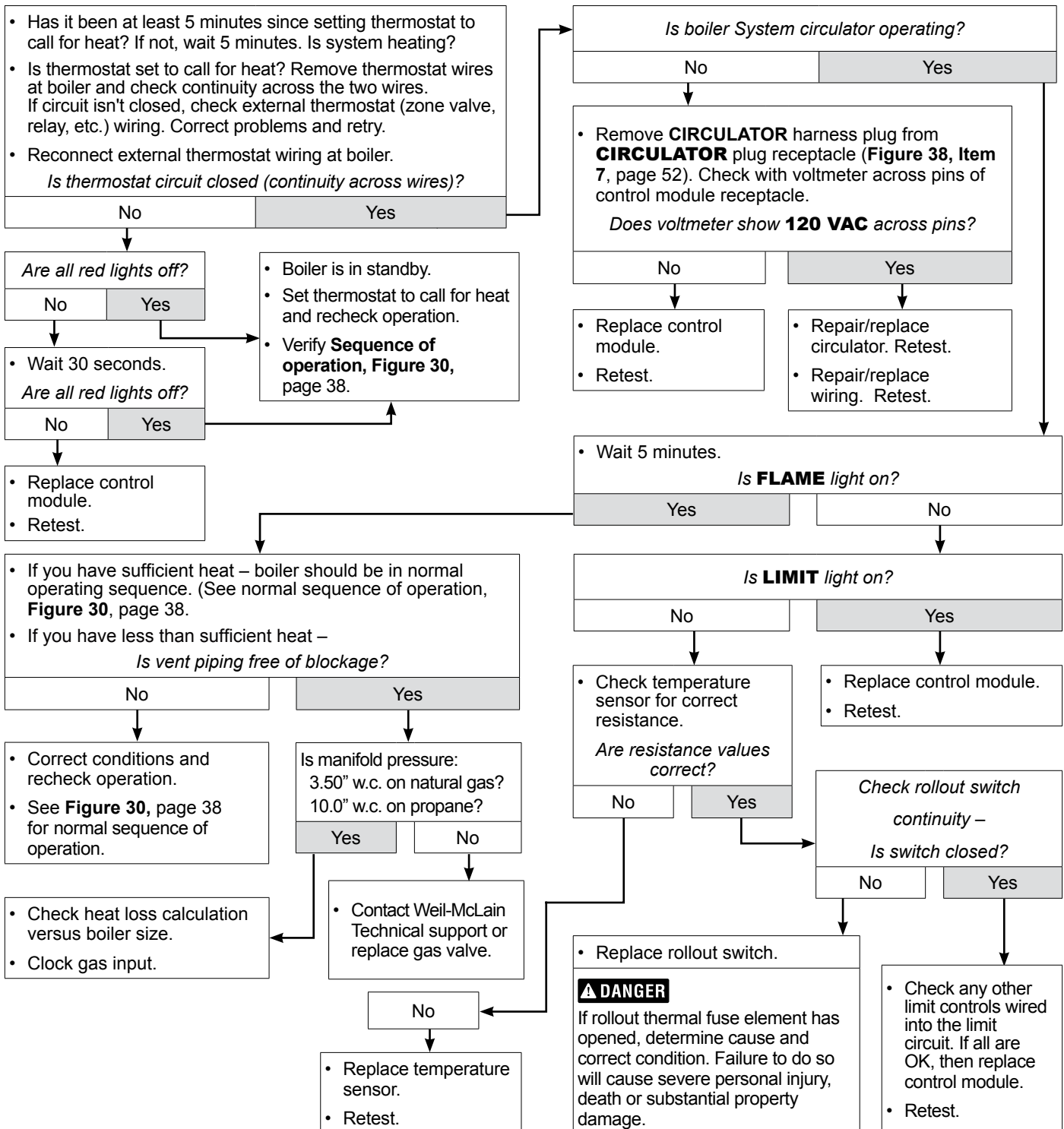





# 12a Replacement parts

**Section assembly ..... 63**

**Base ..... 64**

**Jacket ..... 66**

**Trim ..... 67**

**Controls ..... 68**

**▲WARNING**

Replacement parts must be purchased through a local Weil-McLain distributor. When ordering, specify boiler model and size and include description and part number of replacement part. Results from using modified or other manufactured parts will not be covered by warranty and may damage boiler or impair operation.

**NOTICE**

Weil-McLain part numbers are found in **Weil-McLain Boilers and Controls Repair Parts Lists**.

**▲WARNING**

The boiler contains ceramic fiber and fiberglass materials. Use care when handling these materials per instructions on page 71 of this manual. Failure to comply could result in severe personal injury.

# 12b Replacement parts — section assembly

Figure 39 Section assembly

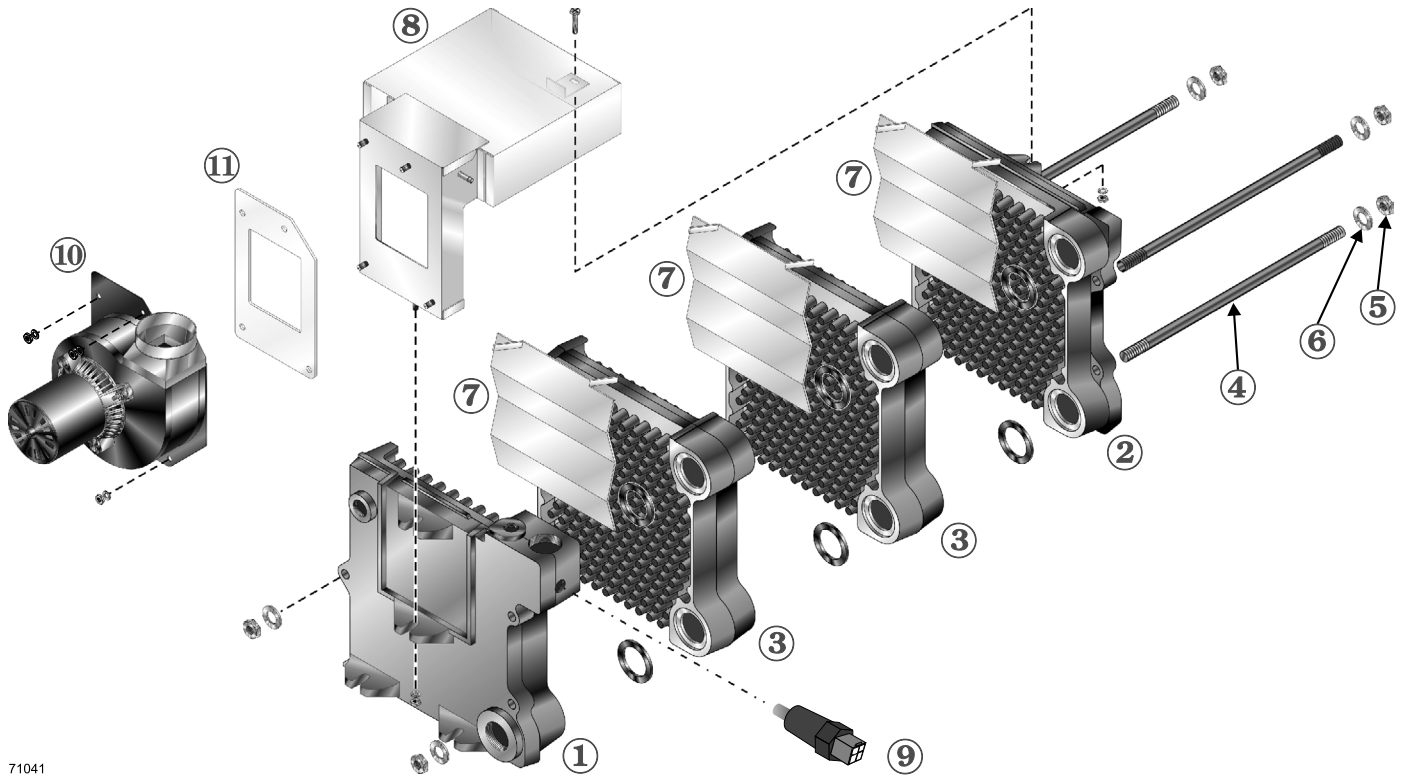

71041

Item	Description	Weil-McLain part number
1	End section, left hand, 51124	<a href="#">311-103-851</a>
2	End section, right hand 51128	<a href="#">311-103-821</a>
3	Intermediate section, 51127	311-103-845
not shown	Replacement section assembly	CGi-25 and CGi-3 321-114-360 CGi-4 321-114-361 CGi-5 321-114-362 CGi-6 321-114-363 CGi-7 321-114-364 CGi-8 321-114-365
not shown	Section replacement kit, includes seals and sealant for 1 joint	<a href="#">381-354-527</a>
4	Tie rod, 7/16" without nut (3 per boiler):	CGi-25 and CGi-3 <a href="#">560-234-500</a> CGi-4 <a href="#">560-234-501</a> CGi-5 <a href="#">560-234-502</a> CGi-6 <a href="#">560-234-503</a> CGi-7 <a href="#">560-234-504</a> CGi-8 <a href="#">560-234-505</a>
5	Nut, 7/16" (2 per tie rod)	<a href="#">561-928-235</a>

Item	Description	Weil-McLain part number
6	Washer, 7/16" (1 per tie rod)	<a href="#">562-248-684</a>
7	Radiation plate (1 per joint)	CGi 4-8 460-003-017
8	Collector hood and transition assembly	CGi-25 381-359-286 CGi-3 <a href="#">381-354-595</a> CGi-4 381-359-288 CGi-5 381-359-289 CGi-6 381-359-290 CGi-7 381-359-291 CGi-8 381-359-292
9	Temperature/LWCO Sensor	<a href="#">381-356-589</a>
10	Inducer fan assembly kit, includes inducer fan assembly, gasket and nuts	CGi 25 & 3 <a href="#">381-354-588</a> CGi 4-6 381-359-293 CGi 7 & 8 381-359-294
11	Gasket, inducer	<a href="#">590-317-627</a>

# 12c Replacement parts — base

**Figure 40** Base assembly

Item	Description		Weil-McLain part number
	Base assembly kit (includes base panels items 1, 2, 3, 4, 5, 6 and 7)	CGi-25 & CGi-3 CGi-4 CGi-5 CGi-6 CGi-7 CGi-8	<a href="#">381-354-337</a> <a href="#">381-354-338</a> <a href="#">381-354-339</a> <a href="#">381-354-340</a> <a href="#">381-354-341</a> <a href="#">381-354-342</a>
1	Base side panel (in Base assembly)		
2	Base front cross-tie assembly (in Base assembly)		
3	Base back cross-tie assembly (in Base assembly)		
4	Burner shield (in Base assembly)		
5	Base pan angle, left side (in Base assembly)		
6	Base pan angle, right side (in Base assembly)		
7	Base pan (in Base assembly)		
7a	Base pan air baffle (in Base assembly)		
8a	Burner mounting plate	CGi-25 & CGi-3 CGi-4 CGi-5 CGi-6 CGi-7 CGi-8	<a href="#">450-003-690</a> <a href="#">450-003-691</a> <a href="#">450-003-692</a> <a href="#">450-003-693</a> <a href="#">450-003-795</a> <a href="#">450-003-796</a>
8b	Rear spacing strip	CGi-25 & CGi-3 CGi-4 CGi-5 CGi-6 CGi-7 CGi-8	<a href="#">550-320-160</a> <a href="#">550-320-161</a> <a href="#">550-320-162</a> <a href="#">550-320-163</a> <a href="#">550-320-164</a> <a href="#">550-320-165</a>
8c	Nut, hex 5mm Zp		<a href="#">550-320-170</a>
9	Base insulation kit	CGi-25 & CGi-3 CGi-4 CGi-5 CGi-6 CGi-7 CGi-8	<a href="#">381-354-330</a> <a href="#">381-354-331</a> <a href="#">381-354-332</a> <a href="#">381-354-333</a> <a href="#">381-354-334</a> <a href="#">381-354-335</a>
10	Boiler leg kit		<a href="#">550-320-219</a>
11	Manifold	CGi-25 & CGi-3 CGi-4 CGi-5 CGi-6 CGi-7 CGi-8	<a href="#">591-126-735</a> <a href="#">591-126-736</a> <a href="#">591-126-737</a> <a href="#">591-126-738</a> <a href="#">591-126-739</a> <a href="#">591-126-740</a>
12	Main burner orifice — Natural gas, sea level (see Table 2, page 12 for orifice size) CGi-25 CGi-3 - CGi-5 CGi-6 - CGi-8  Main burner orifice — Liquefied Petroleum (Propane) gas, sea level (see Table 2, page 12 for orifice size) CGi-25 CGi-3 - CGi-5 CGi-6 - CGi-8		<a href="#">560-529-090</a> <a href="#">560-529-126</a> <a href="#">560-529-077</a>  <a href="#">560-529-084</a> <a href="#">560-529-111</a> <a href="#">560-529-078</a>
13	Burner		<a href="#">512-200-076</a>
14	Screw, 10-32 x 0.38 STP type 23 hex, washer head slot		<a href="#">562-135-710</a>
15	Rollout thermal fuse element		<a href="#">512-050-230</a>



# 12c Replacement parts — base (continued)

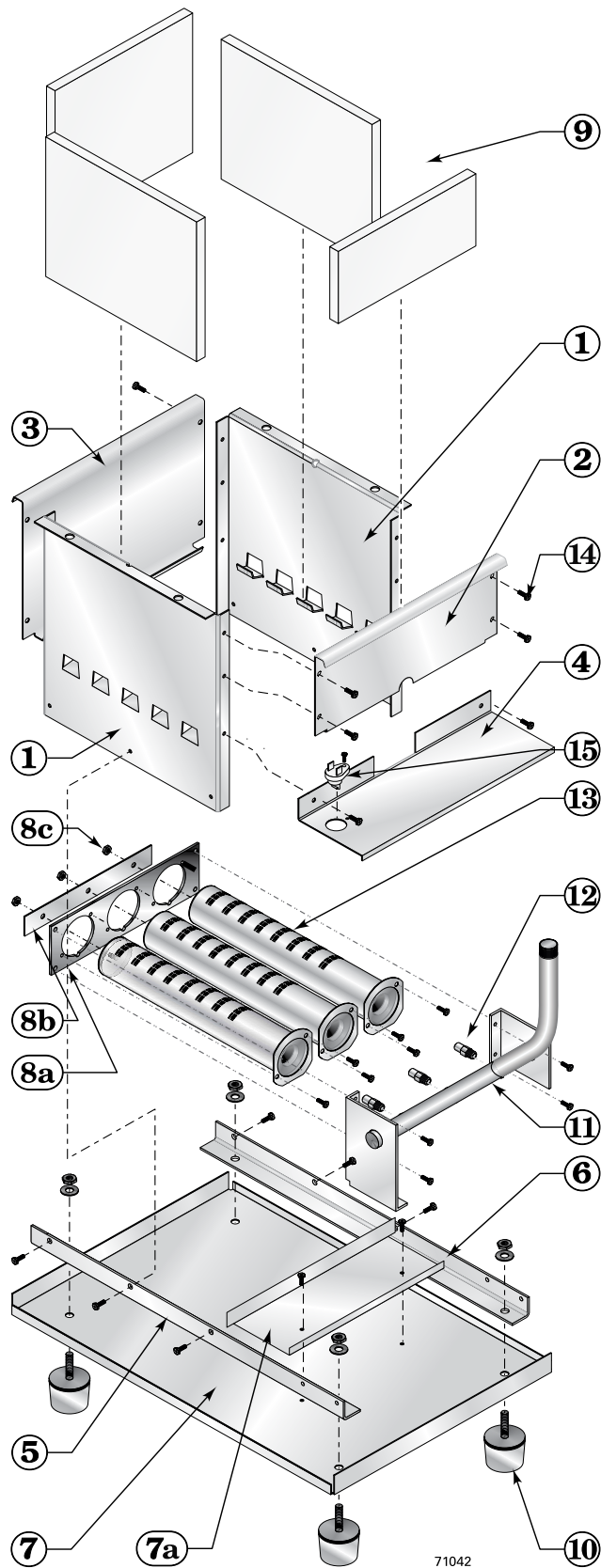

71042



# 12d Replacement parts — jacket

Figure 41 Jacket assembly

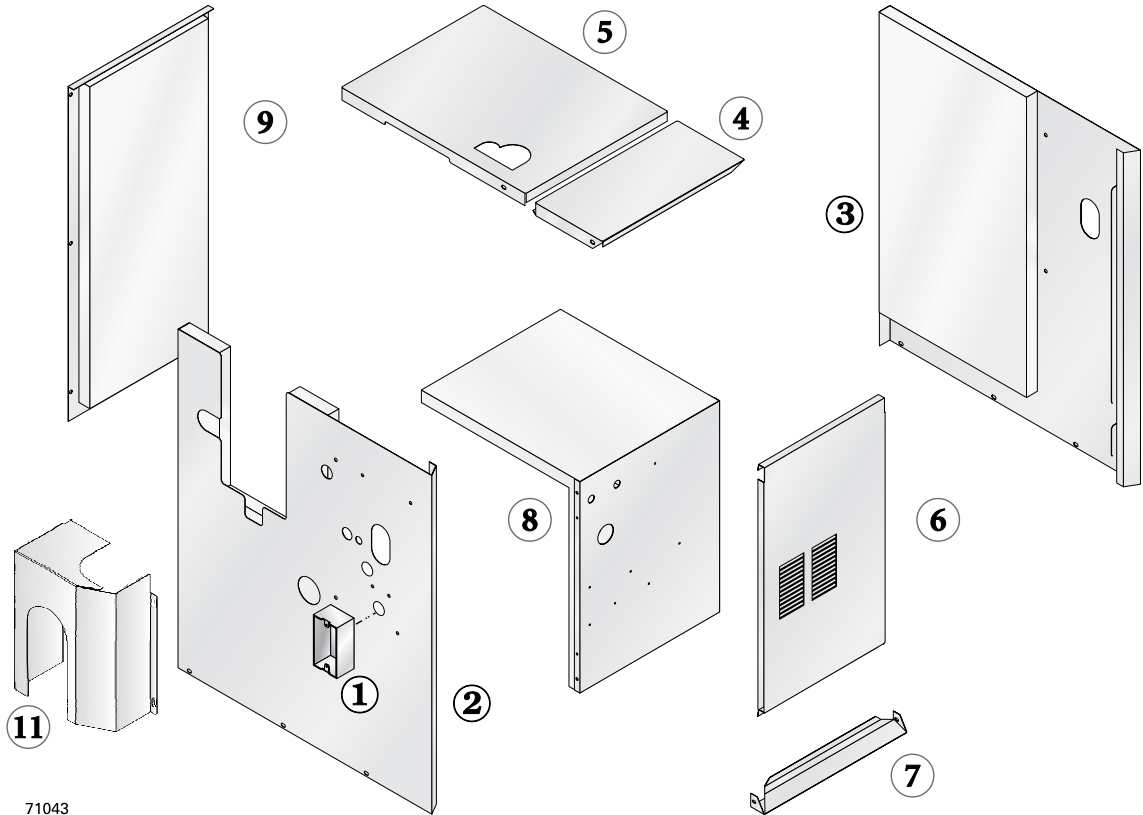

71043

Boiler Model	1	2		3	4	5	Boiler Model
	Junction box, 2 x 4	Panel, left side, with insulation		Panel, right side, with insulation	Panel, top front, with insulation	Panel, top rear, with insulation	
		Natural Gas	Propane Gas				
	Weil-McLain part number						
CGi-25	(Available at local supply house)	381-359-215	381-359-222	381-359-229	381-359-230	381-359-242	CGi-25
CGi-3		381-359-216	381-359-223	381-359-229	381-359-230	381-359-242	CGi-3
CGi-4		381-359-217	381-359-224	381-359-229	381-359-231	381-359-243	CGi-4
CGi-5		381-359-218	381-359-225	381-359-229	381-359-232	381-359-244	CGi-5
CGi-6		381-359-219	381-359-226	381-359-229	381-359-233	381-359-245	CGi-6
CGi-7		381-359-220	381-359-227	381-359-229	381-359-234	381-359-246	CGi-7
CGi-8		381-359-221	381-359-228	381-359-229	381-359-235	381-359-247	CGi-8
Boiler Model		6	7	8	9	10	11
	Panel, door	Cross tie, bottom front	Panel, interior, with insulation	Panel, rear, with insulation	Not shown — touch-up paint	Blower cover	
	Weil-McLain part number						
CGi-25	381-359-254	381-359-260	381-359-266	381-359-272	381-359-278	381-359-200	CGi-25
CGi-3	381-359-254	381-359-260	381-359-266	381-359-272	Cloud		CGi-3
CGi-4	381-359-255	381-359-261	381-359-267	381-359-273	384-000-141 Slate	Optional	CGi-4
CGi-5	381-359-256	381-359-262	381-359-268	381-359-274			CGi-5
CGi-6	381-359-257	381-359-263	381-359-269	381-359-275			CGi-6
CGi-7	381-359-258	381-359-264	381-359-270	381-359-276			CGi-7
CGi-8	381-359-259	381-359-265	381-359-271	381-359-277			CGi-8



# 12e Replacement parts — trim

**Figure 42** Trim assembly

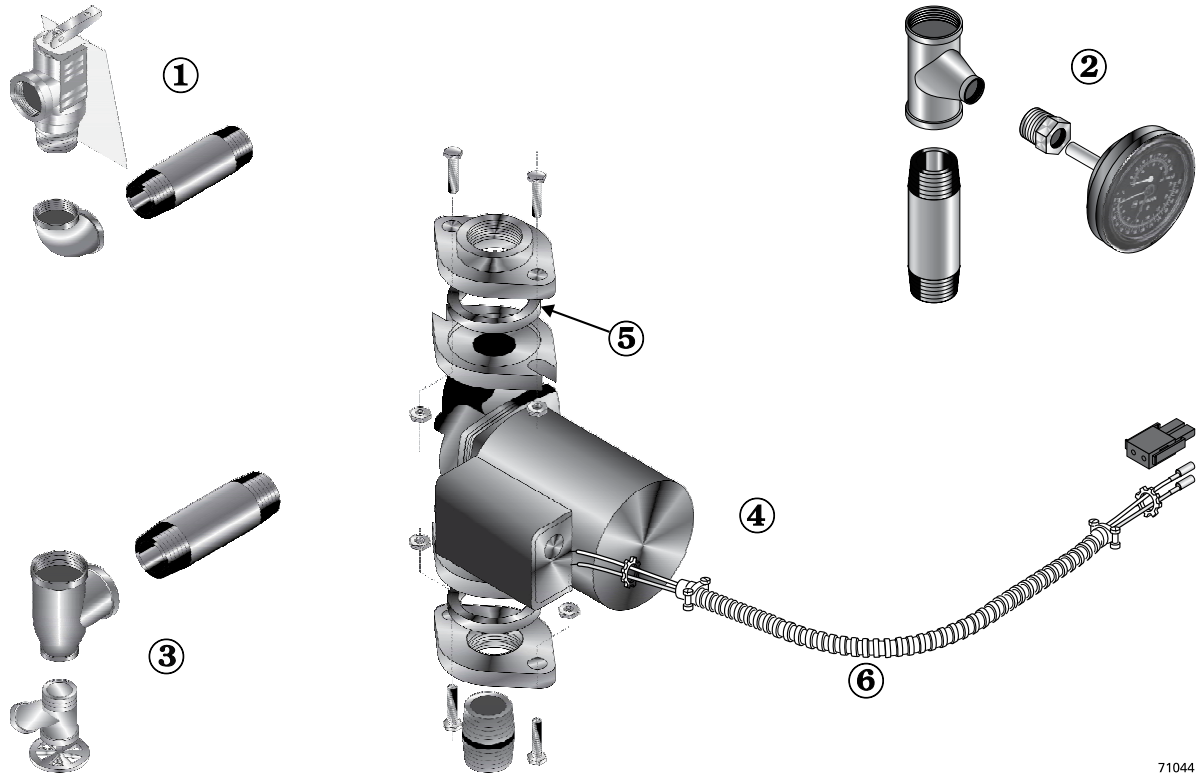

71044

Item number	Description	Weil-McLain part number
1	Pressure relief valve, ASME, 30 PSIG, 3/4" male inlet (Fittings shown are factory-installed on boiler.)	<a href="#">383-500-095</a>
2	Combination pressure-temperature gauge, 3 1/2" diameter, short shank (Fittings shown are shipped loose with boiler.)	<a href="#">380-000-000</a>
3	Drain valve, 3/4" (Fittings shown are included with boiler.)	<a href="#">511-210-423</a> <a href="#">511-246-392</a>
4	Circulator (Fittings shown are shipped loose with boiler.)	CGi-25 through CGi-5 CGi-6 through CGi-8 <a href="#">511-405-153</a> <a href="#">511-405-113</a>
5	Circulator gasket, universal (2 per boiler)	<a href="#">590-317-535</a>
not shown	Circulator hardware kit, includes: 1 flange, 2 nuts, 2 screws, 1 gasket —	3/4" NPT — CGi-25 1" NPT — CGi-3 through CGi-5 1 1/4" NPT — CGi-6 and CGi-7 1 1/2" NPT — CGi-8 <a href="#">381-354-530</a> <a href="#">381-354-525</a> <a href="#">381-354-526</a> <a href="#">381-354-531</a>
6	Circulator wiring harness kit, with Molex (loose)	<a href="#">381-356-528</a>



# 12f Replacement parts — controls

**Figure 43** Gas control assembly

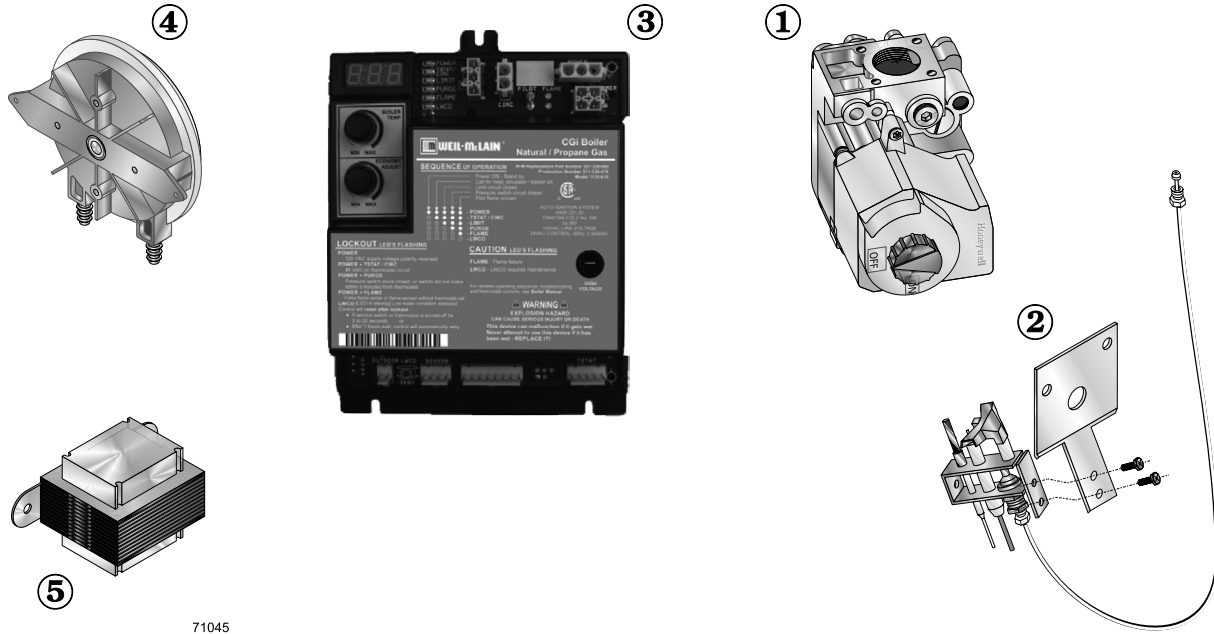

71045

Item number	Description	Boiler model	Weil-McLain part number
<b>Natural gas components</b>			
1	Gas valve, 1/2" x 1/2"	CGi-25 thru -6	<a href="#">511-044-381</a>
	Gas valve, 3/4" x 3/4"	CGi-7 & CGi-8	<a href="#">511-044-353</a>
2	Pilot kit w/orifice & aluminum pilot gas tubing		<a href="#">511-330-080</a>
<b>Propane gas components</b>			
1	Gas valve, 1/2" x 1/2"	CGi-25 thru -6	<a href="#">511-044-354</a>
	Gas valve, 3/4" x 3/4"	CGi-7 & CGi-8	<a href="#">511-044-355</a>
2	Pilot kit w/orifice & aluminum pilot gas tubing		<a href="#">511-330-081</a>
<b>Natural gas and propane gas components</b>			
3	Control module		<a href="#">381-330-040</a>
not shown	Wiring harness - Controls to control module		<a href="#">591-391-978</a>
4	Air pressure switch	CGi-25 CGi-3 CGi-4 CGi-5 CGi-6 CGi-7 CGi-8	<a href="#">381-359-280</a> <a href="#">381-359-280</a> <a href="#">381-359-281</a> <a href="#">381-359-282</a> <a href="#">381-359-283</a> <a href="#">381-359-284</a> <a href="#">381-359-285</a>
5	Control transformer		<a href="#">381-356-578</a>
not shown	Tubing, air pressure switch, 0.12 I.D. silicone red, to collector hood white, to transition		<a href="#">590-317-650</a> <a href="#">590-317-651</a>
not shown	Wiring harness - J-box to control module		<a href="#">591-391-975</a>
not shown	Wiring harness - Thermostat		<a href="#">591-392-006</a>
not shown	Wiring harness - Water Temperature / LWCO Sensor		<a href="#">591-391-995</a>
not shown	Wiring harness - Inducer motor to control module		<a href="#">591-391-980</a>



# 13a Dimensions

**Figure 44** Dimensional drawing

- ① Supply piping (note 1)
- ② Return piping (note 1)
- ③ Relief valve, 3/4" NPT
- ④ 1/2" NPT to expansion tank/air vent
- ⑤ 3" Diameter vent

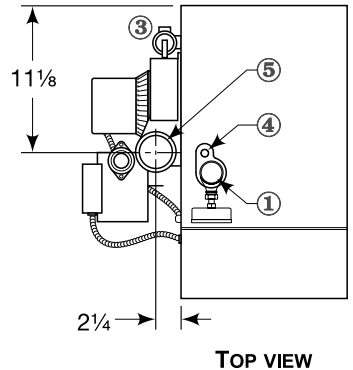

- ⑥ Gas supply piping
- ⑦ Drain valve
- ⑧ Gas supply entrance (right or left side)
- ⑨ Pressure/temperature gauge

**Note 1:** Boiler supply and return tapings are both 1 1/4" NPT. See **Table 6**, page 20 for recommended system supply and return piping sizes.

**Note 2:** Boiler circulator is shipped loose. Circulator may be mounted on either boiler supply or return piping. Circulator flange provided with boiler is same size as recommended pipe size in **Table 6**, page 20.

ALL DIMENSIONS IN INCHES

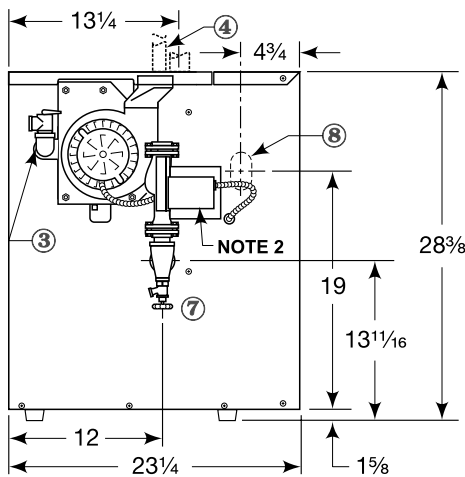

71046

LEFT SIDE

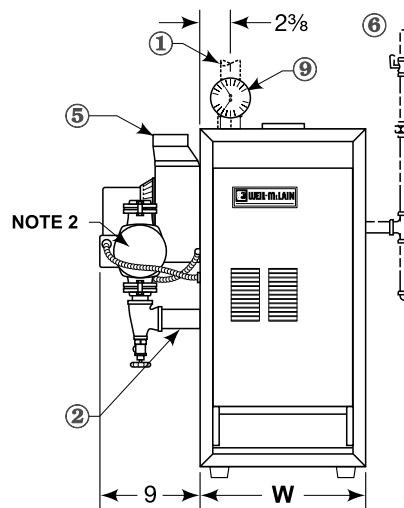

FRONT

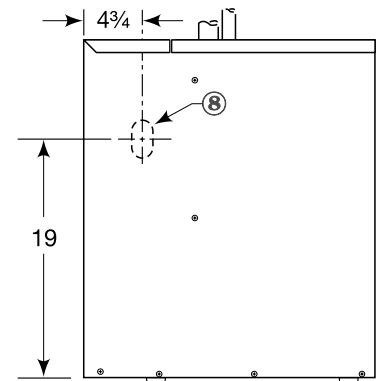

RIGHT SIDE

Boiler model number	Supply tapping (inches NPT)	Return tapping (inches NPT)	Gas connection size Note 3 (inches NPT)	Gas manifold size Note 3 (inches NPT)	"W" Jacket width (inches)
CGi-25	1 1/4	1 1/4	1/2	1/2	10
CGi-3	1 1/4	1 1/4	1/2	1/2	10
CGi-4	1 1/4	1 1/4	1/2	1/2	13
CGi-5	1 1/4	1 1/4	1/2	1/2	16
CGi-6	1 1/4	1 1/4	1/2	1/2	19
CGi-7	1 1/4	1 1/4	3/4	3/4	22
CGi-8	1 1/4	1 1/4	3/4	3/4	25

Note 3: Gas piping from meter to boiler to be sized per local utility requirements.



# 13b Ratings

**Table 11** Boiler ratings

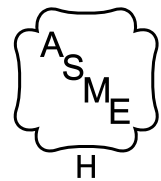

Boiler model number	0 - 2,000 feet Altitude		2,000 - 4,500 feet Altitude		AHRI Certified Ratings			Boiler water content Gallons	Vent size Inches (Note 4)
	Input (Btuh)	Output (Btuh)	Input (Btuh)	Output (Btuh)	Heating Capacity Btuh (Note 2)	Seasonal Efficiency AFUE %	Net Ratings (water) Btuh (Note 3)		
	(Note 1)								
<b>CGi-25</b>	48,000	40,000	43,000	36,000	41,000	84.0	35,000	1.5	3"
<b>CGi-3</b>	58,000	49,000	52,000	43,000	49,000	84.0	42,000	1.5	3"
<b>CGi-4</b>	90,000	76,000	81,000	68,000	77,000	84.0	66,000	2.1	3"
<b>CGi-5</b>	119,000	100,000	107,000	90,000	102,000	84.0	88,000	2.7	3"
<b>CGi-6</b>	158,000	133,000	142,000	119,000	135,000	84.0	117,000	3.3	3"
<b>CGi-7</b>	190,000	160,000	171,000	143,000	162,000	84.0	140,000	3.8	3"
<b>CGi-8</b>	222,000	186,000	200,000	168,000	189,000	84.0	164,000	4.4	3"

<b>Notes</b>	1. Add "PIN" for Natural gas boiler - "PIL" for Liquefied Petroleum (propane) gas boiler.
	2. Based on standard test procedures prescribed by the United States Department of Energy.
	3. Net AHRI ratings are based on net installed radiation of sufficient quantity for the requirements of the building and nothing need be added for normal piping and pickup. Ratings are based on a piping and pickup allowance of 1.15. An additional allowance should be made for unusual piping and pickup loads.
	4. CGi boilers require special venting, consistent with Category I, or III boilers. Use only the vent materials and methods specified in this manual. Vent diameter shown above is for direct exhaust venting. See Table 3, page 14, for vent diameter when chimney draft venting.

**NOTICE** CGi boilers for residential radiant panel systems, converted gravity heating systems or other low water temperature applications should be installed with balancing valves and bypass piping equal to the supply and return size to avoid excessive flue gas condensation due to lower operating water temperatures. CSA design certified for installation on combustible flooring. Tested for 50 psi working pressure.

## Handling ceramic fiber and fiberglass materials

### REMOVAL OF COMBUSTION CHAMBER LINING OR BASE PANELS

#### **▲WARNING**

The combustion chamber lining or base insulation panels in this product contain ceramic fiber materials that have been identified as carcinogenic, or possibly carcinogenic, to humans. Ceramic fibers can be converted to cristobalite in very high temperature applications. The International Agency for Research on Cancer (IARC) has concluded, "Crystalline silica inhaled in the form of quartz or cristobalite from occupational sources is carcinogenic to humans (Group 1).":

#### *Precautionary measures*

- Avoid breathing fiberglass dust and contact with skin or eyes.
  - Use NIOSH certified dust respirator (N95). This type of respirator is based on the OSHA requirements for fiberglass wool at the time this document was written. Other types of respirators may be needed depending on the job site conditions. Current NIOSH recommendations can be found on the NIOSH web site at <http://www.cdc.gov/niosh/homepage.html>. NIOSH approved respirators, manufacturers, and phone numbers are also listed on this web site.
  - Wear long-sleeved, loose fitting clothing, gloves, and eye protection.
- Apply enough water to the combustion chamber lining or base insulation to prevent airborne dust.
- Remove combustion chamber lining or base insulation from the boiler and place it in a plastic bag for disposal.
- Wash potentially contaminated clothes separately from other clothing. Rinse clothes washer thoroughly.

#### *NIOSH stated First Aid.*

- Eye: Irrigate immediately.
- Breathing: Fresh air.

### REMOVAL OF FIBERGLASS WOOL

or

### INSTALLATION OF FIBERGLASS WOOL, COMBUSTION CHAMBER LINING OR BASE PANELS:

#### **▲WARNING**

This product contains fiberglass jacket insulation and ceramic fiber materials in combustion chamber lining or base panels in gas fired products. Airborne fibers from these materials have been listed by the State of California as a possible cause of cancer through inhalation.

#### *Precautionary measures*

- Avoid breathing fiberglass dust and contact with skin or eyes.
  - Use NIOSH certified dust respirator (N95). This type of respirator is based on the OSHA requirements for fiberglass wool at the time this document was written. Other types of respirators may be needed depending on the job site conditions. Current NIOSH recommendations can be found on the NIOSH web site at <http://www.cdc.gov/niosh/homepage.html>. NIOSH approved respirators, manufacturers, and phone numbers are also listed on this web site.
  - Wear long-sleeved, loose fitting clothing, gloves, and eye protection.
- Operations such as sawing, blowing, tear out, and spraying may generate airborne fiber concentration requiring additional protection.
- Wash potentially contaminated clothes separately from other clothing. Rinse clothes washer thoroughly.

#### *NIOSH stated First Aid.*

- Eye: Irrigate immediately.
- Breathing: Fresh air.



WM Technologies, LLC  
500 Blaine Street  
Michigan City, IN 46360-2388  
[weil-mclain.com](http://weil-mclain.com)