

# EVERGREEN® Pro

CONDENSING GAS BOILER  
220/299/300/399

## Boiler Manual

- Installation
- Maintenance
- Startup
- Parts



**WARNING**

This manual must only be used by a qualified heating installer/service technician. Read all instructions, including this manual and all other information shipped with the boiler, before installing. Perform steps in the order given. Failure to comply could result in severe personal injury, death or substantial property damage.



# The Evergreen<sup>®</sup> Gas-fired water boilers

1. **Stainless steel firetube heat exchanger**
2. **Burner access cover/heat exchanger cover plate**
3. **Blower**

The advanced blower design and air inlet silencer on Evergreen<sup>®</sup> boilers result in very quiet operation. Air enters the boiler enclosure through the air intake adapter (Item 20), flows through the enclosure, enters the air inlet silencer (Item 5), then enters the venturi (Item 6) where it mixes with gas before entering the blower. The blower pulls air through these components and then pushes it through the cover plate to the burner (Item 11).

4. **Gas valve**

The automatic gas valve references the pressure in the Evergreen<sup>®</sup> cabinet and allows gas to flow when the control (Item 17) applies power. A manual gas valve is shipped loose with the boiler. It allows shutting off the gas supply for servicing or shut down. See instructions in this manual for manual gas valve installation.

5. **Air inlet silencer**

The horn-shaped air inlet silencer significantly reduces fan noise, providing exceptionally quiet operation.

6. **Venturi**

When air flows through the venturi, a negative pressure is created. This causes gas to flow from the gas valve into the venturi, where it is mixed with the air. The gas/air mixture then continues into the blower.

7. **Outlet water temperature dual sensor**

This dual sensor monitors boiler outlet water temperature. The control adjusts boiler firing rate so the outlet water temperature is correct, based on the calculated (if outdoor reset used — see page 129) or fixed target temperature.

8. **Return water temperature sensor**

This sensor monitors return water temperature. The control reduces or increases boiler input, depending on how close the return water temperature is to the outlet water temperature.

9. **Electronic display & interface buttons**

The electronic display is used to configure boiler settings and monitor boiler operation. The buttons allow changing display mode, selecting and adjusting control settings, and resetting the control after lockout.

10. **Flue adapter (fits 4" PVC)**

11. **Burner**

The high-grade stainless steel burner uses pre-mixed air and gas to provide a modulating flame to the heat exchanger.

12. **Ignition electrode**

The burner flame is ignited by applying a high voltage to the ignition electrode. This causes a spark from the electrode to ground.

13. **Flame sense rod**

After ignition, this measures the flame signal to provide a safe combustion at all times.

14. **Water outlet pipe (supply) (1½" NPT)**

15. **Water inlet pipe (return) (1½" NPT)**

16. **Gas line**

This stainless steel flexible gas line connects the incoming gas line to the gas valve. The gas line has a ¾" NPT connection for installation.

17. **Evergreen<sup>®</sup> control (see discussion upper right)**

18. **Circulator/Communication Board**

The circulator/communication board provides boiler-to-boiler communication, Building Management System (BMS) interface, and 120VAC power for the boiler loop circulator.

19. **Transformer**

The 120VAC/24VAC transformer provides 24VAC to low voltage control circuitry. Do NOT splice wiring into transformer.

20. **Air intake adapter (fits 4" PVC)**

- 21a & 21b. **Electrical entrances**

The four (4) knockouts on the left side of the control tray are intended for low voltage and boiler pump wiring, and the four knockouts on the right side are intended for the line voltage and three high voltage outputs from the control.

22. **Air pressure switch**

Air pressure switch monitors air flow by sensing changes in pneumatic pressure.

23. **Flue gas condensate drain**

Connect the boiler internal condensate trap line to the heat exchanger here (parts supplied with boiler, but field installed).

24. **Control access panel (not shown)**

Remove when power is off to access the control.

25. **Flue gas condensate drain connection**

The condensate trap PVC fittings are field-installed, connected to the condensate trap line as shown in this manual.

## Evergreen<sup>®</sup> control overview

- The Evergreen<sup>®</sup> control can operate a single boiler or coordinate with other Evergreen<sup>®</sup> boilers in a multiple boiler system.
- Control inputs and outputs allow operation of multiple heating circuits (space heating and DHW, for example).
- Up to three priority levels can be set, providing automatic switch-over on demand.
- This manual provides quick set-up information for single boiler installations.
- The Advanced Manual, available at Weil-McLain.com, provides instructions for setting up multiple-boiler systems and for using advanced options for single boilers.

## Evergreen<sup>®</sup> control operation

- The control responds to signals from the room thermostats, DHW aquastats (if used), boiler sensors (boiler return, boiler supply, flue temperature), outdoor temperature and system sensor, if used.
- The control automatically adjusts blower speed (and gas flow rate) to match boiler output to space heating and/or DHW heating demand.
- The default control settings provide for three space heating zones. The control can be easily set up for operation with a DHW zone, with or without domestic priority.

## Evergreen<sup>®</sup> control WIZARD

- The control setup Wizard is available from the BOILER SETTINGS menu that appears during initial startup.
- The Wizard leads through a step-by-step setup procedure designed for the application chosen.
- Context-sensitive help is available to explain the purpose of key setup items.

26. **Front door**

The front door is sealed to the boiler assembly around its entire perimeter.

27. **Front door latches**

Two latches secure the door in place.

28. **Flame inspection window**

The quartz glass window provides a view of the burner surface and the flame.

29. **Flue gas dual sensor**

This dual sensor monitors the flue gas exit temperature. The control will shut down the boiler if flue gas temperature gets too hot. This protects the flue pipe and the heat exchanger from overheating.

30. **ON/OFF switch**

31. **Boiler drain valve (not shown)**

Shipped loose for field installation. See instructions in this manual.

32. **Boiler relief valve (not shown)**

Shipped loose for field installation. See instructions in this manual.

33. **Boiler pressure/temperature gauge (not shown)**

Shipped loose for field installation. See instructions in this manual.

34. **Manual gas shutoff valve (not shown)**

Shipped loose for field installation. See instructions in this manual.

35. **Leveling Legs**

The leveling legs are adjustable to level the boiler.

36. **Receptacle**

The receptacle can be used for a condensate pump 2 amp maximum.

37. **Top panel hatch**

Remove this panel when removing the burner.

38. **Control tray inspection window**

Provides a better view of the burner and flame.



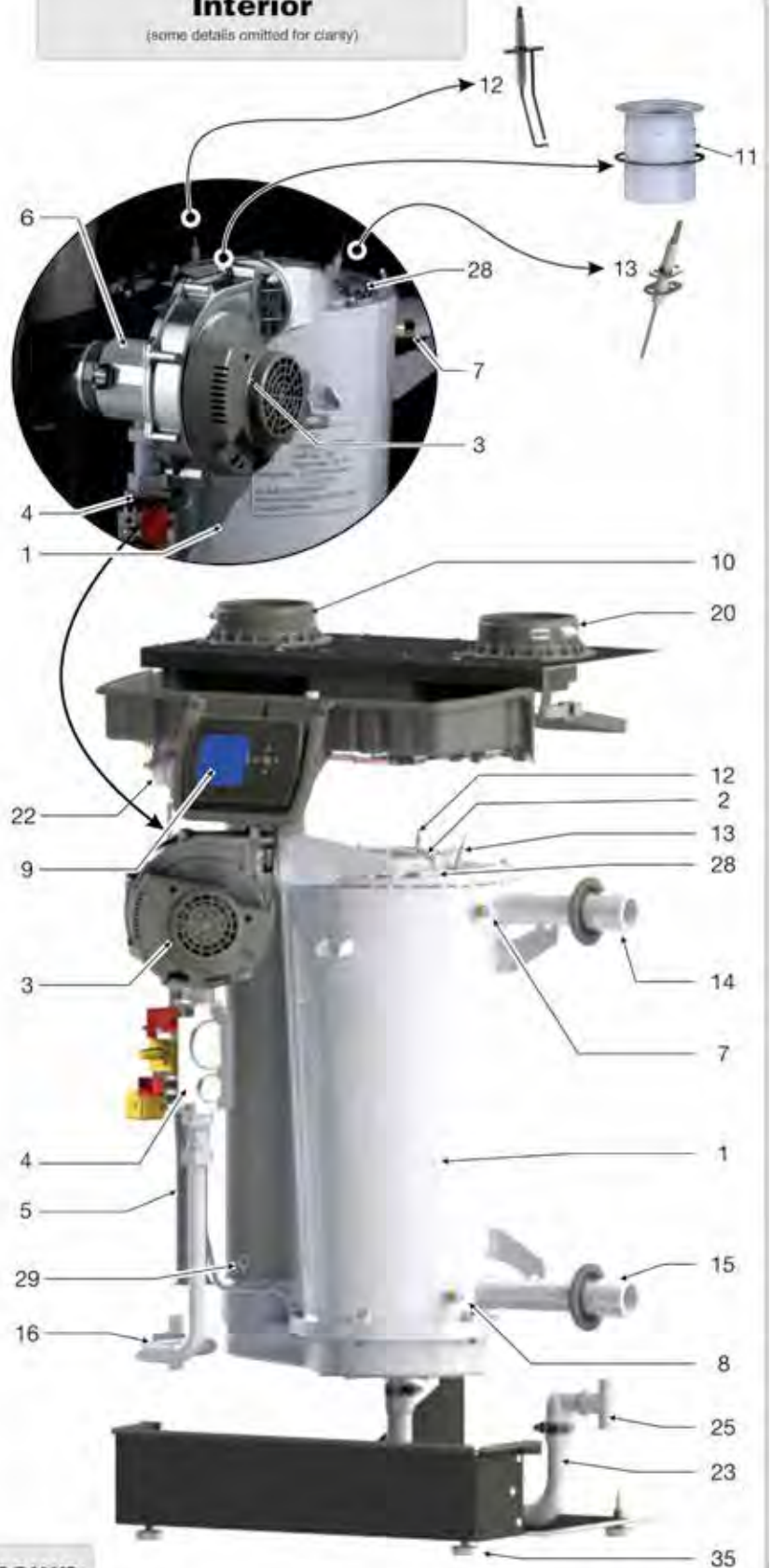
# The Evergreen® Gas-fired water boiler *(continued)*

## Front right



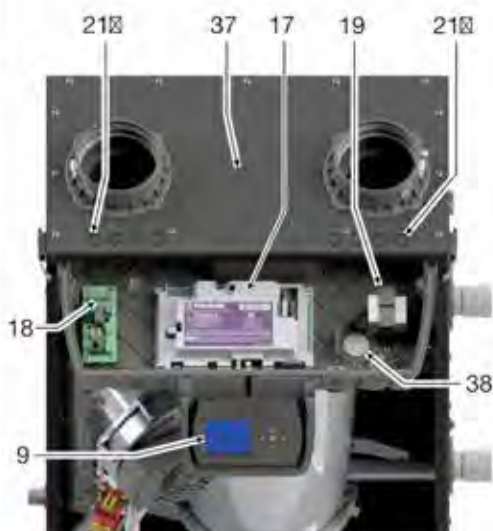
## Interior

(some details omitted for clarity)



## Control tray

(Control access panel (24) removed for clarity)



220 Shown



# Contents

The Evergreen® Gas-fired water boilers . . . . . 2  
 Please read before proceeding . . . . . 5  
 Boiler location . . . . . 6  
 Prepare boiler location . . . . . 8  
 Wall-mounting the boiler . . . . . 8  
 Boiler hydrostatic test . . . . . 10  
 Gas conversions . . . . . 12  
 Gas piping — sizing gas lines . . . . . 18  
 Venting/air piping — general . . . . . 19  
 Commonwealth of Massachusetts installations . . . . . 22  
 Vent termination requirements . . . . . 23  
 Boiler room air openings . . . . . 24  
 DIRECT VENT — Sidewall with separate pipes . . . . . 25  
 DIRECT VENT — Sidewall with W-M vent/air plate . . . . . 27  
 DIRECT VENT — Sidewall concentric . . . . . 29  
 DIRECT VENT — Vertical with separate pipes . . . . . 31  
 DIRECT VENT — Vertical concentric . . . . . 33  
 Concentric termination, typical (sidewall or vertical) . . . . . 35  
 DIRECT VENT — Vertical vent / sidewall air . . . . . 36  
 Vent and air piping and boiler connections . . . . . 38  
 Install water piping . . . . . 39  
 Expansion tank . . . . . 42  
 Install condensate line . . . . . 49  
 Gas piping . . . . . 51  
 Field wiring . . . . . 52  
 Wiring diagram — schematic . . . . . 59  
 Wiring diagram — ladder . . . . . 60  
 Zoning with the EVG Control . . . . . 61  
 Evergreen Control operation . . . . . 63  
 EXPRESS SETUP — Example A . . . . . 68  
 EXPRESS SETUP — Example B . . . . . 70  
 EXPRESS SETUP — Example C . . . . . 72

**⚠ WARNING** DO NOT SERVICE THE BOILER WITHOUT A Evergreen® MAINTENANCE KIT AVAILABLE

The Evergreen® maintenance kit includes components that may have to be replaced when accessing or disassembling parts of the boiler. Failure to replace damaged components and to use only the parts specifically intended for the boiler can result in severe personal injury, death or substantial property damage. See [Figure 111, page 117](#) for part number.

Available control settings and system presets . . . . . 74  
 CONTRACTOR menus . . . . . 75  
 BOILER SETTINGS menu, BASIC mode . . . . . 76  
 PRIORITY 1, 2, 3 menus, BASIC mode . . . . . 77  
 ASSIGN INPUTS menu, BASIC mode . . . . . 78  
 DIAGNOSTIC menu . . . . . 80  
 MAINTENANCE, DATE AND TIME menus . . . . . 85  
 Startup — fill the system . . . . . 86  
 Startup — final checks . . . . . 88  
 Check-out/startup verification . . . . . 92  
 Annual startup and general maintenance . . . . . 93  
 Annual startup . . . . . 94  
 Manual Test Mode for Single and Multiple Boilers . . . . . 101  
 Troubleshooting . . . . . 102  
 Maintenance . . . . . 110  
 Cleaning heat exchanger flue side . . . . . 111  
 Replacement parts . . . . . 116  
 Dimensions . . . . . 128  
 Ratings . . . . . 129  
 Ratings — Multiple boilers . . . . . 130  
 Installation and Service Certificate . . . . . 131  
 Installation and Gas Boiler Data Collection Sheet . . . . . 132

## Hazard definitions

The following defined terms are used throughout this manual to bring attention to the presence of hazards of various risk levels or to important information concerning the life of the product.

**⚠ DANGER** Indicates presence of hazards that will cause severe personal injury, death or substantial property damage.

**⚠ WARNING** Indicates presence of hazards that can cause severe personal injury, death or substantial property damage.

**⚠ CAUTION** Indicates presence of hazards that will or can cause minor personal injury or property damage.

**NOTICE** Indicates special instructions on installation, operation or maintenance that are important but not related to personal injury or property damage.



# Please read before proceeding

**WARNING** **Installer**— Read all instructions, including this manual and all other information shipped with the boiler, before installing. Perform steps in the order given.

**User** — This manual is for use only by a qualified heating installer/service technician. Refer to User's Information Manual for your reference.

**User** — Have this boiler serviced/inspected by a qualified service technician, at least annually. Failure to comply with the above could result in severe personal injury, death or substantial property damage.

**NOTICE** Write in the CP number in the space provided on the Installation certificate on [page 131](#) if not already shown.

When calling or writing about the boiler— Please have the boiler model number from the boiler rating label and the CP number from the boiler jacket.

Consider piping and installation when determining boiler location.

Any claims for damage or shortage in shipment must be filed immediately against the transportation company by the consignee.

**DANGER** **If any part of a boiler, burner or its controls has been sprayed with or submerged under water, either partially or fully, DO NOT attempt to operate the boiler until the boiler has been either replaced or completely repaired, inspected, and you are sure that the boiler and all components are in good condition and fully reliable.**

Otherwise, by operating this boiler, you will cause a fire or explosion hazard, and an electrical shock hazard, leading to serious injury, death, or substantial property damage. See the instructions at right.

**Saltwater Damage** — The exposure of boiler components to saltwater can have both immediate and long-term effects. While the immediate effects of saltwater damage are similar to those of freshwater (shorting out of electrical components, washing out of critical lubricants, etc.), the salt and other contaminants left behind can lead to longer term issues after the water is gone due to the conductive and corrosive nature of the salt residue. Therefore, Weil-McLain equipment contaminated with saltwater or polluted water will no longer be covered under warranty and should be replaced.

**Electrical Damage** — If any **electrical component** or **wiring** came into contact with water, or was suspected to have come into contact with water, replace the boiler with a new Weil-McLain boiler.

**WARNING** Failure to adhere to the guidelines below can result in severe personal injury, death or substantial property damage.

## EXPANSION TANK

Relieve pressure from the system before isolating the expansion tank.

### When servicing boiler —

- To avoid electric shock, disconnect all electrical supplies to the boiler before performing maintenance.
- To avoid severe burns, allow boiler to cool before performing maintenance.
- This boiler contains ceramic fiber and fiberglass materials. Refer to the **WARNING** and instructions on [page 94](#).

### Boiler operation —

- Do not block flow of combustion or ventilation air to boiler.
- Should overheating occur or gas supply fail to shut off, do not turn off or disconnect electrical supply to pump. Instead, shut off the gas supply at a location external to the appliance.

### Combustion air —

- DO NOT install combustion air intake where there is a risk of combustion air contamination.

### Carbon monoxide detector —

- A carbon monoxide detector that is wired on the same electrical circuit as the boiler is strongly recommended.

### SURGE PROTECTOR —

- Provide surge protection in the boiler power supply. This will reduce the possibility of damage to the boiler control.

### Boiler water —

- The Evergreen heat exchanger is made of stainless steel, and requires that system water chemistry be within the limits in this manual. **ADDITIONAL CHEMICAL TREATMENT MAY BE NECESSARY.** See [page 86](#) for details.
- Thoroughly flush the system (**BEFORE** connecting boiler) to remove sediment. The high-efficiency heat exchanger can be damaged by build-up or corrosion due to sediment.

- Do not use petroleum-based cleaning or sealing compounds in boiler system. Gaskets and seals in the system may be damaged. This can result in substantial property damage.

- Continual fresh make-up water will reduce boiler life. Mineral buildup in heat exchanger reduces heat transfer, overheats the stainless steel heat exchanger, and causes failure. Addition of oxygen carried in by make-up water can cause internal corrosion. Leaks in boiler or piping must be repaired at once to

prevent make-up water. Use this boiler **ONLY** in a closed-loop system.

- Do not add cold water to a hot boiler. Thermal shock can cause heat exchanger to crack.

### Freeze protection fluids —

- NEVER use automotive or standard glycol antifreeze. Use only freeze-protection fluids made for hydronic systems. Follow all guidelines given by the antifreeze manufacturer. Thoroughly clean and flush any replacement boiler system that has used glycol before installing the new boiler

### CAUTION Frozen Water Damage Hazard

Residences or buildings that are unattended in severely cold weather, boiler system components failures, power outages, or other electrical system failures could result in frozen plumbing and water damage in a matter of hours. For your protection, take preventative actions such as having a security system installed that operates during power outages, senses low temperature, and initiates an effective action. Consult with your boiler contractor or a home security agency.

## Commonwealth of Massachusetts

- When the boiler is installed within the Commonwealth of Massachusetts:
- This product must be installed by a licensed plumber or gas fitter.
  - If antifreeze is used, a reduced pressure back-flow preventer device shall be used.
  - Sidewall vent air installations — see instruction on [page 22](#).



# Boiler location

## Installations must comply with:

- Local, state, provincial, and national codes, laws, regulations and ordinances.
- National Fuel Gas Code, ANSI Z223.1/NFPA 54 - latest edition.
- National Electrical Code.
- For Canada only: CAN/CSA B149.1, Natural Gas and Propane Installation Code, and any local codes.

**NOTICE**

The Evergreen<sup>®</sup> boiler gas manifold and controls met safe lighting and other performance criteria when boiler underwent tests specified in ANSI Z21.13 — latest edition.

## Flooring

1. The boiler **must not** be installed on carpeting.

**WARNING**

Do not install boiler on carpeting even if foundation is used. Fire can result, causing severe personal injury, death or substantial property damage.

## Before locating the boiler, check:

2. The boiler is suitable for INDOOR installation only.
3. Check for nearby connection to:
  - System water piping
  - Venting connections
  - Gas supply piping
  - Electrical power
  - Condensate drain
4. Check area around boiler. Remove any combustible materials, gasoline and other flammable liquids.

**WARNING**

Failure to keep boiler area clear and free of combustible materials, gasoline and other flammable liquids and vapors can result in severe personal injury, death or substantial property damage.

5. The boiler must be installed such that the gas ignition system components are protected from water (dripping, spraying, rain, etc.) during appliance operation and service (circulator replacement, condensate trap, control replacement, etc.).
6. If new boiler will replace existing boiler, check for and correct system problems, such as:
  - Sediment or corrosion in system piping — clean and flush piping BEFORE connecting the new boiler. See [page 86](#).
  - System leaks causing oxygen corrosion or heat exchanger cracks from hard water deposits.
  - Incorrectly-sized expansion tank.
  - Lack of freeze protection in boiler water causing system and boiler to freeze and leak.

## Residential garage installation

### Precautions

1. Take the following special precautions when installing the boiler in a residential garage. If the boiler is located in a residential garage:
  - Mount the boiler with its bottom at least 18 inches above the floor. This complies with the National Fuel Gas Code, ANSI Z223.1 NFPA 54 -latest edition for U. S. installations, or Natural Gas and Propane Installation Code, CAN/CSA B149.1 and B149.2 for Canadian installations.

- Locate or protect the boiler so it cannot be damaged by a moving vehicle.
- Ensure that the installation complies with all applicable codes.
- Prevent boiler water and condensate from freezing.

## Provide air openings to room

### Evergreen<sup>®</sup> boiler alone in boiler room (Direct Vent)

1. No air ventilation openings into boiler room are needed if clearances around Evergreen<sup>®</sup> boiler are at least equal to the SERVICE clearances shown in [Figure 1, page 7](#).
2. For spaces that DO NOT supply the minimum service clearances, provide two openings as shown in [Figure 1, page 7](#). Each opening must provide 1 square inch free area per 1,000 Btuh of boiler input.

### Evergreen<sup>®</sup> boiler in same space with other gas or oil-fired appliances

1. Follow the sizing requirements shown in [Figure 26, page 24](#).

**WARNING**

The space must be provided with combustion/ventilation air openings correctly sized for all appliances located in the same space as the Evergreen<sup>®</sup> boiler.

Reinstall boiler jacket front door after servicing. The boiler front door must be securely fastened to the boiler to prevent boiler from drawing air from inside the boiler room. This is particularly important if the boiler is located in the same room as other appliances.

Failure to comply with the above warnings could result in severe personal injury, death or substantial property damage.

## Vent and air piping

1. The Evergreen<sup>®</sup> boiler requires a special vent system, designed for pressurized venting. Evergreen<sup>®</sup> boilers are rated ANSI Z21.13 Category IV (pressurized vent, likely to condense in the vent). See instructions beginning on [page 19](#).
2. You must also install air piping from outside to the boiler air intake adapter. The resultant installation is categorized as direct vent (sealed combustion). Note prevention of combustion air contamination on [page 19](#) when considering vent/air termination.
3. Vent and air must terminate near one another unless otherwise specified in this manual. Vent and air piping may be routed vertically through the roof or out a side wall, following the options give in this manual. You may use any of the vent/air piping methods covered in this manual. Do not attempt to install the boiler using any other means.
4. Be sure to locate the boiler such that the vent and air piping can be routed through the building and properly terminated. The vent/air piping lengths, routing and termination method must all comply with the methods and limits in instructions beginning on [page 19](#).



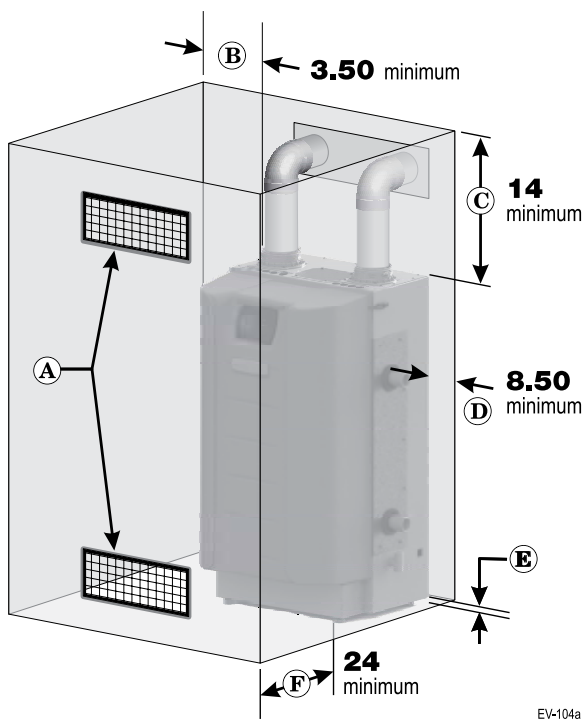
# Boiler location *(continued)*

## Provide clearances for service access — RECOMMENDED

1. See Figure 1 for recommended service clearances.
2. If you do not provide minimum service clearances shown, it might not be possible to service the boiler without removing it from the space.

**⚠WARNING** Closet or small-enclosure installations which do not provide at least these recommended clearances require the specially-sized and placed air openings shown in Figure 2.

**Figure 1** RECOMMENDED service clearances (all dimensions are in inches)



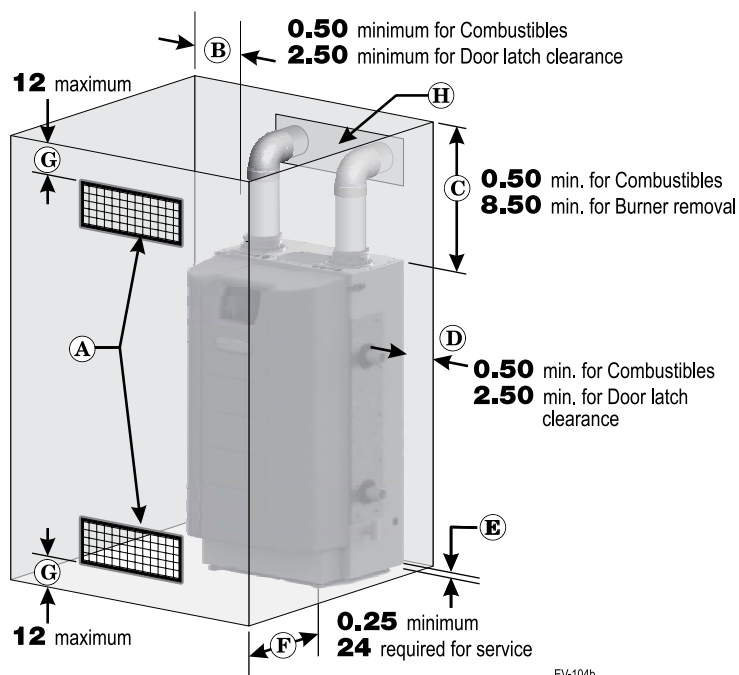
EV-104a

## Provide clearances from combustible materials — REQUIRED

1. See Figure 2 for REQUIRED minimum clearances. ALL installation must provide at least these minimums.
2. Hot water pipes — at least 1/2" from combustible materials.
3. Vent pipe — at least 3/16" from combustible materials.
4. See Figure 1 for service clearance minimums.

**⚠WARNING** Closet or small-enclosure installations which do not provide at least the recommended service clearances shown in Figure 1 require the specially-sized and placed air openings shown in Figure 2.

**Figure 2** REQUIRED minimum clearances (all dimensions are in inches)



EV-104b

A Provide combustion air/ventilation openings per Figure 26, page 24 or as otherwise directed in this manual or by applicable codes. **NOTE:** If the installation does not provide the minimum clearances in this illustration, then the enclosure must have air openings located and sized per Figure 2.

B Left side service clearance = 3.50 inches minimum.

C Service clearance above top of boiler = 14 inches minimum.

D Right side service clearance = 8.50 inches minimum.

E Service clearance below the boiler = 0 inches minimum.

F Service clearance in front of the boiler = 24 inches minimum.

**NOTICE**

ADDITIONAL service clearance may be needed, depending on how piping is routed to the boiler.

A Provide combustion air/ventilation openings per Figure 26, page 24 or as otherwise directed in this manual or by applicable codes. **NOTICE** If the installation does not provide the minimum clearances in Figure 1, then the enclosure MUST HAVE air openings located per Figure 2, above. Each of these air openings must have free area of at least 1 square inch per 1,000 MBH of boiler input.

B Left side clearance to combustibles = 0.50 inches minimum, but 2.5" for door latch removal.

C Top of boiler clearance to combustibles = 0.50 inches minimum, but 8.5" for burner removal.

D Right side clearance to combustibles = 8.50 inches minimum, but 2.5" for door latch removal.

E Bottom of boiler clearance to combustibles = 0 inches minimum (must be 18 inches above floor for garage installations).

F Clearance in front of the boiler = 0.25 inches, but 24 inches minimum required for service.

G Air openings must be located in the FRONT of the enclosure, as shown. They must be no more than 12 inches from the floor or ceiling, as shown.

H Vent pipe must be minimum 3/16 inch from combustibles. Opening in combustible wall, floor, ceiling or roof must be 3/8" larger than flue pipe diameter, fitted with galvanized steel thimble, or larger if required by codes or as specified by vent pipe manufacturer.



# Prepare boiler location

## Flooring and foundation

### Flooring

1. The boiler is approved for installation on combustible flooring, but must never be installed on carpeting.

**⚠WARNING** Do not install boiler on carpeting even if foundation is used. Fire can result, causing severe personal injury, death or substantial property damage.

### Foundation

1. Provide a solid foundation pad, at least 2 inches above the floor, if any of the following is true:
  - floor can become flooded.
  - the floor is dirt, sand, gravel or other loose material.
  - the boiler mounting area is severely uneven or sloped.
2. The minimum foundation size is:
  - Evergreen®: 24 inches wide x 24 inches deep
3. Foundation may be of wood, brick or concrete (minimum 2 inches thick) construction.

If flooding is possible, elevate boiler sufficiently to prevent water from reaching boiler.

## Remove boiler from crate

**⚠WARNING** **The boiler is heavy.** Use caution not to drop the boiler or cause bodily injury while lifting and handling. Verify that the boiler is securely attached to prevent possibility of boiler falling after installation.

**⚠CAUTION** **Cold weather handling** — If boiler has been stored in a very cold location (below 0°F) before installation, handle with care until the plastic components come to room temperature.

1. The Evergreen® boiler is generally easier to handle and maneuver after removing the shipping container.
2. Remove items 1, 2, 4, and 5 in Figure 3. Remove trim kit and parts from item 6.
3. After removing outer shipping carton from boiler, REMOVE jacket front door by opening door latches. Removing the door will prevent possible damage to the door during handling.
4. Remove the additional trim kits from inside the boiler.
5. To remove boiler from pallet (after removing jacket front door):
  - a. Remove the lag screws securing the shipping brackets.
  - b. Unscrew the two (2) rear boiler legs and remove the shipping brackets and discard. The shipping brackets are NOT to be used for wall mounting.
  - c. Discard the cardboard protector insert on the rear of the boiler.

**NOTICE** Do not drop boiler or bump jacket on floor or pallet. Damage to boiler can result.

## Placing floor-mounted boilers

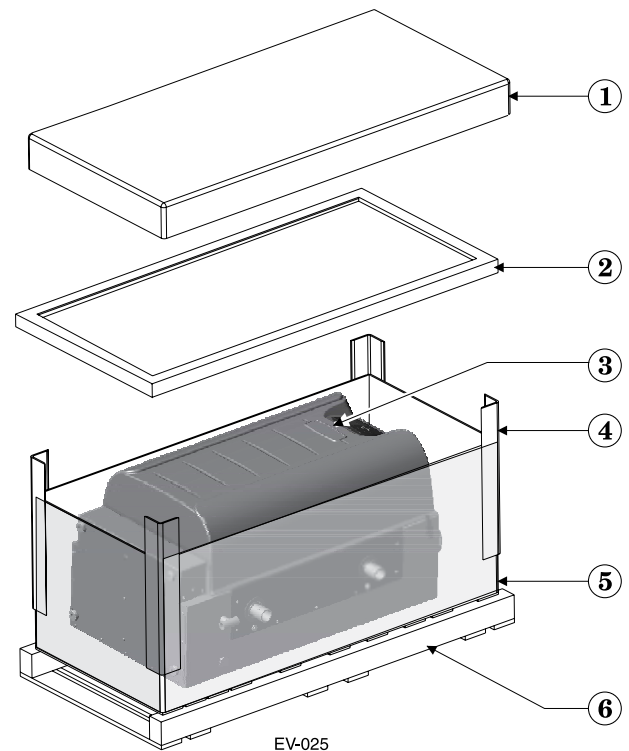
1. Set boiler in place, plumb and level.
  - a. Adjust legs, if necessary to plumb and/or level boiler.

## Wall-mounted boilers

1. Boilers can be wall mounted ONLY if using the optional wall-mount kit available from Weil-McLain.

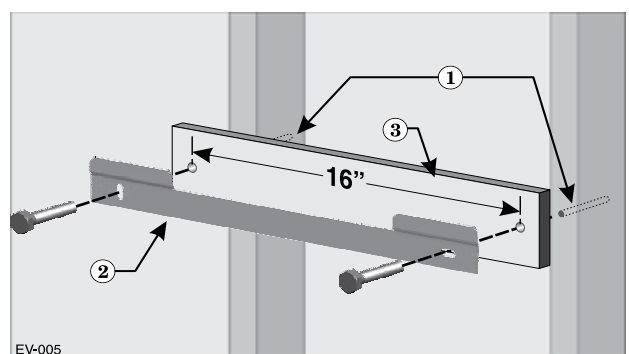
# Wall-mounting the boiler

Figure 3 Boiler shipping container



- |   |                    |   |                          |
|---|--------------------|---|--------------------------|
| 1 | Cardboard cap, top | 4 | Cardboard corners        |
| 2 | Cardboard support  | 5 | Cardboard outside sleeve |
| 3 | Boiler             | 6 | Pallet                   |

Figure 4 Wall-mount bracket and spacer board



1. Studs — Pre-drill through the wall into the studs ¼ inch diameter x 3 inches deep for 3/8-inch lag screws— Studs must be on 16-inch centers. If studs are any other spacing, provide a secure, solid mounting surface on which to attach the boiler wall-mounting bracket.
  2. Wall-mount bracket.
  3. Provide a spacer board pre-drilled with two clearance holes, spaced on 16 inch centers. Board must be **minimum** ½ inch thick by 3½" high by 18 inches long. Clearance holes (2) should be ½" diameter for 3/8-inch lag bolts or ¼" diameter for 3/16-inch toggle bolts.
- RECOMMENDED for drywall or plaster lathe.



# Wall-mounting the boiler *(continued)*

## Wall-mounting requirements

The wall-mounting kit is NOT supplied with the boiler, and must be purchased separately.

2. Verify kit contents:
  - a. Wall-mount bracket
  - b. Lag screws, 3/8" hex head x 3" (2)
3. Verify mounting location:
  - a. Wood stud wall: install bracket with lag screws included in kit, directly into the studs.
  - b. Metal stud wall: secure bracket to studs with 3/16" toggle bolts and flat washers (not included with kit).

**⚠ WARNING** Verify that the studs are suitable for carrying a wall-mounted load. Some metal studs are not designed for this purpose.

## Wall-mounting instructions

1. Locate studs. Bracket holes are spaced for 16" center studs. For other stud spacing, provide secure, solid mounting structure on which to attach the wall-mounting bracket.

**⚠ WARNING** DO NOT attempt to attach the wall mount bracket using anchors or any means other than directly securing to the wall studs (or equivalent wood structure if studs are not on 16-inch centers).

**The boiler must be vertically plumb and capable of carrying the weight of the boiler and any attached components.**

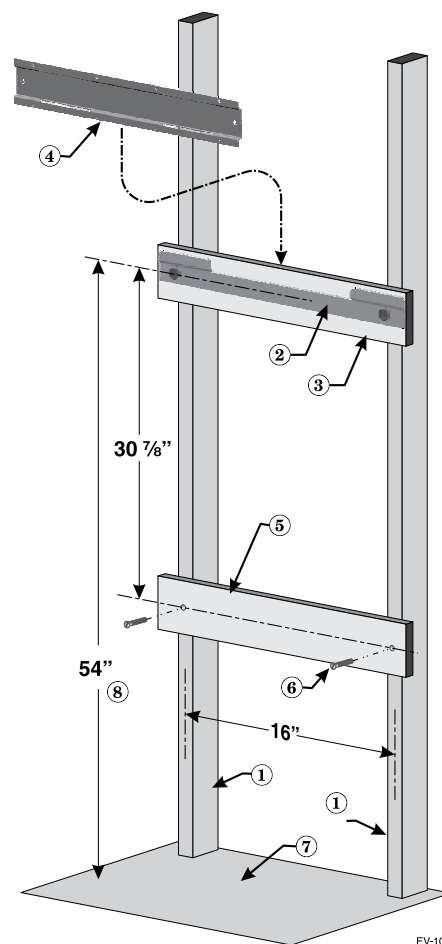
The operating weights for Evergreen<sup>®</sup> models are:

Evergreen 220:	<b>190 pounds</b>
Evergreen 299/300:	<b>255 pounds</b>
Evergreen 399:	<b>255 pounds</b>

Failure to comply with above and the procedure given below could result in severe personal injury, death or substantial property damage.

2. Optional – If boiler is being mounted on drywall or similar surface, provide spacer boards to be installed as shown in [Figure 4, page 8](#) and [Figure 5](#). The boards must be a minimum of 1/2" thick. Prepare upper board by tracing the mounting slots on the board, and drilling two 1/4" through holes in the center of the outlines. Skip to step 5.
3. Place the wall-mount bracket on the wall so that the mounting slots are centered over the studs (see [Figure 4, page 8](#)). If using a backing board, skip this step.
4. Level the bracket using a level and trace the outline of the screw slots with a pencil. If using a backing board, skip this step.
5. Remove the wall-mounting bracket and drill 1/4" diameter by 3" deep holes, centered in the bracket slot outlines. For metal stud walls using 3/16" toggle bolts, drill required clearance holes. If using a backing board, use the upper board as a template to drill two (2) 1/4" by 3" deep holes into the wall studs.
6. Position the bracket (and upper spacer board, if used) on the wall. Insert and loosely tighten the two (2) lag screws (or toggle bolts for metal studs).
7. Level the wall-mounting bracket, and tighten lag screws so bracket is secured. For installations using a backing board, avoid over-tightening the screws to avoid damage to the wall surface.

**Figure 5** Place boiler on wall-mount bracket



- 1 Studs — Pre-drill through the wall into the studs 1/4 inch diameter x 3 inches deep — Studs must be on 16-inch centers. If studs are any other spacing, provide a secure, solid mounting surface on which to attach the boiler wall-mounting bracket.
- 2 Wall-mount bracket — secure wall mount bracket and space bar to wall as instructed on previous page.
- 3 Upper spacer board — (Recommended for drywall or plaster lathe)
- 4 Boiler mounting bracket — The two slots in the bracket on back of boiler must engage with the two tabs on the wall bracket. This piece is attached to the boiler. (The boiler is not shown to improve clarity.)
- 5 Lower space board — Provide lower spacer board pre-drilled with two clearance holes, spaced on 16 inch centers. Board must be **minimum** 1/2 inch thick by 3 1/2" high by 18 inches long. Use minimum two flat-head wood screws by 2 inches long to secure the space board securely to the studs. Clearance holes should large enough to clear the shaft of the flat-head wood screws used to secure the board to the studs. (RECOMMENDED for drywall or plaster lathe).
- 6 Flat-head wood screws by 2" long.
- 7 Floor surface.
- 8 RECOMMENDED mounting height — for garage installations.



## Wall-mounting the boiler *(continued)*

8. If upper spacer board is used, install the lower spacer board as shown in [Figure 5, page 9](#).
9. Once the wall-mount bracket is installed, measure 35" below the bottom edge of the bracket and strike a line or place a piece of masking tape with the top edge even with the 35" mark. This line will indicate if the boiler has been properly seated in the hanging bracket.
10. **Obtain assistance to lift the boiler into position.**

**⚠ WARNING** The boiler is heavy, and requires two people to lift and place. Wear non-slip rubber gloves to prevent possibility of cuts from sheet metal edges.

The jacket door can be left on boiler, but boiler must ONLY be lifted from the bottom and rear of the sheet metal housing, NOT from the pipes or any plastic part.

11. Lift the boiler high enough that its rear bracket (item 4, [Figure 5, page 9](#)) will be above the wall-mount bracket.
12. Slide the boiler down so that the back of the cabinet is in contact with the lag screw heads until the bottom of the boiler is below the line or tape placed in Step 9. If necessary, move boiler left or right until the tabs on the wall-mounting bracket insert into the back of the cabinet.

**⚠ WARNING** When mounting the boiler, use the method described in Step 9 to ensure the cabinet is fully seated on wall mounting bracket. If the bracket is not fully engaged, the boiler could fall. Failure to comply could result in severe personal injury, death, or substantial property damage.

## Boiler hydrostatic test

**⚠ WARNING** DO NOT install a relief valve with a pressure higher than 80 PSIG. This is the maximum allowable relief valve setting for the Evergreen<sup>®</sup> boiler. Failure to comply could prevent the relief valve from operating as needed, resulting in possibility of severe personal injury, death or substantial property damage.

**⚠ WARNING** Use two wrenches when tightening any pipe connection to the boiler. Failure to prevent the boiler pipes from turning could damage pipes, resulting in possible severe personal injury, death or substantial property damage.

### Hydrostatic pressure test

Pressure test the boiler before permanently attaching water or gas piping or electrical supply.

### Install pipe fittings for relief valve and P/T gauge

1. Install the (Item 5a) two 1½" reducing tee (EVG 220 model) or two 1½" tees (EVG 299/300 & 399 models), and close nipple shipped loose with the boiler, located and oriented as shown in [Figure 6, page 11](#) and [Figure 7, page 11](#), on the boiler supply and return.
2. Install the (Item 5b) one 1¼" NPT tee on EVG 220 or 1½" NPT tee on EVG 299/300/399) and close nipples shipped loose with the boiler, located and oriented as shown in [Figure 6, page 11](#) on the boiler supply.

**⚠ WARNING** DO NOT install the relief valve until after the hydrostatic test. Temporarily install a ¾" pipe plug in the relief valve location as directed in these instructions. The plug must be removed after the test.

3. Apply pipe dope to all fittings sparingly.

### Install fittings and valves required for hydrostatic testing

1. The following piping components (supplied by installer) are required for the test configuration:
  - a. Two isolation shut-off valves (1¼" NPT on EVG 220; 1½" NPT on EVG 299/300/399).
  - b. 1¼" NPT or 1½" NPT pipe nipples as shown in [Figure 7, page 11](#).
  - c. ¾" NPT pipe plug.
2. **TEMPORARILY** insert a ¾" NPT pipe plug in the relief valve tapping. After the hydrostatic test, this plug must be removed and the relief valve must be installed.
3. Install Pressure/Temperature gauge into the tee (Item 5b) as shown in [Figure 7, page 11](#).

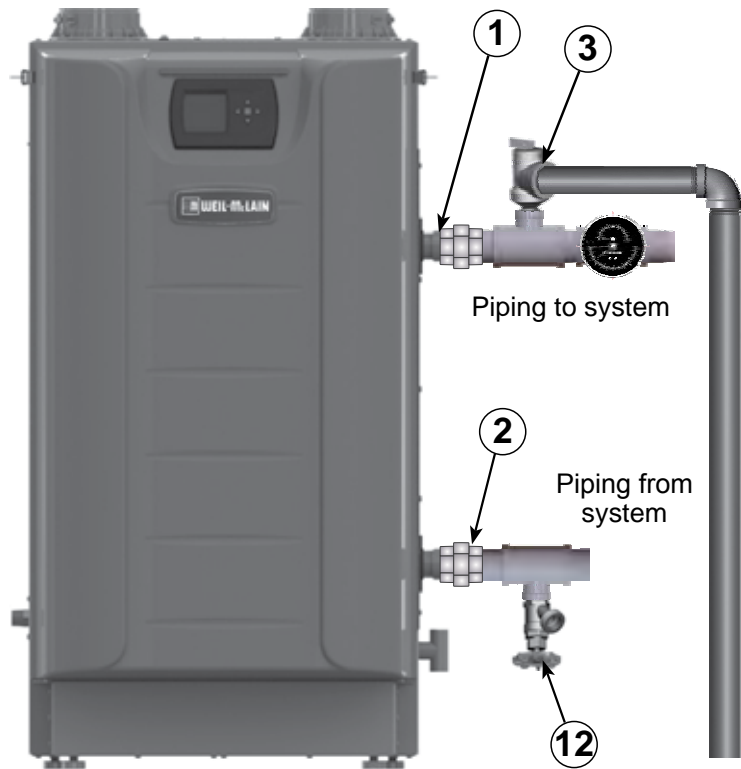
### Fill and pressure test

1. See [Figure 6, page 11](#) for use with the following instructions.
2. CLOSE boiler drain valve (item 12). Connect a hose to fresh water supply and to the drain valve.
3. Place a bucket under the ends of Isolation shut-off valves (item 10 and item 11) to catch water drippage.
4. CLOSE isolation valve 11. (Return)
5. OPEN top isolation valve 10. (Supply)
6. Slowly open boiler drain valve (item 12) and fresh water supply to fill boiler with water. The boiler and internal piping will fill quickly because of the low water content.



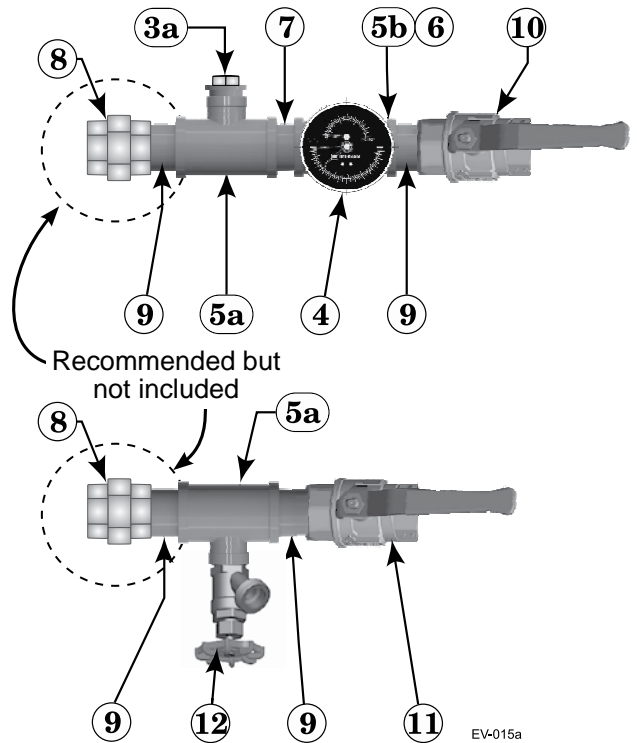
# Boiler hydrostatic test *(continued)*

**Figure 6** Install piping fittings for relief valve and pressure/temperature gauge — **DO NOT mount relief valve until AFTER hydrostatic testing** (see legend below)



EV-015

**Figure 7** Install piping components required for hydrostatic test (see legend below)



EV-015a

## Legend for Hydrostatic Testing

- |  |  |
|--|--|
| <p>1 Boiler supply (outlet) connection, male 1½” NPT.</p> <p>2 Boiler return connection, male 1½” NPT.</p> <p>3 Boiler relief valve, shipped loose with boiler — <b>DO NOT mount relief valve until AFTER hydrostatic testing.</b></p> <p>3a <b>TEMPORARILY ONLY</b> — Insert a ¾” NPT plug in the relief valve tapping of the reducing tee.<br/><b>This MUST BE REMOVED after the test and the relief valve mounted here.</b></p> <p>4 Pressure/temperature gauge, shipped loose with boiler.</p> <p>5a Reducing tee, NPT, 1½” x 1¼” x ¾” on EVG 220 or 1½” x 1½” x ¾” on EVG 299/300/399, shipped loose with boiler.</p> <p>5b Reducing tee, NPT 1¼” x 1¼” x ¼” on EVG 220 or 1½” x 1½” x ¾” on EVG 299/300/399, shipped loose with boiler.</p> <p>6 Bushing, ¾” NPT x ¼” on EVG 299/300/399, shipped loose with boiler.</p> | <p>7 Nipple, 1¼” NPT x close or 1½” NPT x close, shipped loose with boiler.</p> <p>8 Unions, 1 ½” NPT by installer (recommended, but NOT furnished).</p> <p>9 Pipe nipple, 1¼” NPT x close or 1½” NPT x close, by installer.</p> <p>10 Isolation valve on supply connection, by installer (1¼” NPT on EVG 220, 1 ½” NPT on EVG 299/300/399).</p> <p>11 Isolation valve on return connection, by installer (1¼” NPT on EVG 220, 1½” NPT on EVG 299/300/399).</p> <p>12 ¾” NPT boiler drain valve, shipped loose with boiler — after hydrostatic testing, move drain valve to lowest point on the return piping.</p> |
|--|--|



## Boiler hydrostatic test

(continued)

7. When water begins to exit from the supply outlet, close the boiler drain valve (item 12).
8. OPEN isolation valve 11. Close this valve when water begins to run from the return isolation shut-off valve (item 11).
9. Continue filling by opening the boiler drain valve (item 12) until water flows from supply outlet isolation shut-off valve (item 10). Then CLOSE isolation valve 10.
10. The test pressure should be 1-½ times the pressure setting of the relief valve to be installed on the boiler (45 psig for a 30-psig relief valve; 75 psig for a 50-psig relief valve; or 120 psig for a 80-psig relief valve). Open boiler drain valve until desired pressure is achieved.
11. Hold at test pressure for 10 minutes.

**▲WARNING** Do not leave boiler unattended. A cold water fill could expand and cause excessive pressure, resulting in severe personal injury, death or substantial property damage.

12. Make sure constant gauge pressure has been maintained throughout test. Check for leaks. Repair if found.

**▲WARNING** Leaks must be repaired at once. Failure to do so can damage boiler, resulting in substantial property damage.

**▲WARNING** Do not use petroleum-based cleaning or sealing compounds in boiler system. Gaskets and seals in the system may be damaged. This can result in substantial property damage.

## Drain and remove fittings

1. Disconnect fill water hose from water source.
  2. Drain boiler through drain valve.
- ▲WARNING** Use caution when releasing pressure from the boiler. Rapid water flow could cause injury.
3. Remove hose after draining.
  4. Remove nipples and valves unless they will remain for use in the system piping.
  5. Remove plug and install relief valve as specified in the following WARNING.

**▲WARNING** Remove plug from relief valve tee. Install the relief valve in the ¾” tee, see [page 41](#) to install relief valve discharge piping. Failure to install the boiler relief valve could result in severe personal injury, death or substantial property damage.

## Gas conversions

### Prepare boiler for propane — Evergreen® 220/299/300/399 (if required)

#### Propane operation

**▲WARNING** ALL Evergreen® boilers must be converted for propane operation.

**Converting an existing natural gas-fired boiler for propane** — For a boiler already installed, you must turn off gas supply, turn off power and allow boiler to cool before proceeding. You must also completely test the boiler after conversion to adjust gas valve to proper setting, verify performance, and start up the boiler following instructions beginning on [page 86](#) of this manual.

**Verify propane gas venturi**— See [Figure 9, page 13](#) LP gas venturi will have a black label and will be clearly labeled “LP”.

Must change control settings to proper gas type.

Failure to comply could result in severe personal injury, death or substantial property damage.

### ▲WARNING

**This conversion kit shall be installed by a qualified service agency in accordance with the manufacturer’s instructions and all applicable codes and requirements of the authority having jurisdiction. If the information in these instructions is not followed exactly, a fire, an explosion or production of carbon monoxide may result causing property damage, personal injury or loss of life. The qualified service agency is responsible for the proper installation of this kit. The installation is not proper and complete until the operation of the converted appliance is checked as specified in the manufacturer’s instructions.**

**Figure 8** Natural and Liquefied Petroleum (Propane) gas conversion kits

### Natural Gas to Liquefied Petroleum (Propane) conversion kits

EVG 220 LP P/N 540-202-849 NG to Propane Gas Conversion Kit contents:		
511-050-236	Venturi - Liquefied Petroleum (Propane) Gas	1
562-150-292	Screw Pan Hd T20 M4x12 w/Square Cone Lock Washer	3
562-248-765	Washer .89 ID x 1.19 OD Garlock	1
590-318-102	O-Ring 3mm x 70mm Black	1
590-318-103	Gasket 1-Lips EPDM Ring 60 Dia MM	1
550-225-336	Label Gas Conversion	1
550-143-004	Instructions Conversion Nat to LP Gas	1



## Gas conversions *(continued)*

### Natural Gas to Liquefied Petroleum (Propane) conversion kits *(continued)*

EVG 299/300 LP P/N 540-202-841 NG to Propane Gas Conversion Kit contents:		
511-050-220	Venturi - Liquefied Petroleum (Propane) Gas	1
562-150-292	Screw Pan Hd T20 M4x12 w/Square Cone Lock Washer	3
562-248-765	Washer .89 ID x 1.19 OD Garlock	1
590-318-102	O-Ring 3mm x 70mm Black	1
590-318-103	Gasket 1-Lips EPDM Ring 60 Dia MM	1
550-225-336	Label Gas Conversion	1
550-142-871	Instructions Conversion Nat to LP Gas	1

EVG 399 LP P/N 540-202-842 NG to Propane Gas Conversion Kit contents:		
511-050-221	Venturi - Liquefied Petroleum (Propane) Gas	1
562-150-292	Screw Pan Hd T20 M4x12 w/Square Cone Lock Washer	3
562-248-765	Washer .89 ID x 1.19 OD Garlock	1
590-318-102	O-Ring 3mm x 70mm Black	1
590-318-103	Gasket 1-Lips EPDM Ring 60 Dia MM	1
550-225-336	Label Gas Conversion	1
550-142-871	Instructions Conversion Nat to LP Gas	1

### Liquefied Petroleum (Propane) to Natural Gas conversion kits

EVG 220 NG P/N 383-900-054 LP to Natural Gas Conversion Kit contents:		
511-050-212	Venturi - Natural Gas	1
562-150-292	Screw Pan Hd T20 M4x12 w/Square Cone Lock Washer	3
562-248-765	Washer .89 ID x 1.19 OD Garlock	1
590-318-102	O-Ring 3mm x 70mm Black	1
590-318-103	Gasket 1-Lips EPDM Ring 60 Dia MM	1
550-225-336	Label Gas Conversion	1
550-142-160	Instructions Conversion LP to Natural Gas	1

EVG 299/300 NG P/N 383-900-055 LP to Natural Gas Conversion Kit contents:		
511-050-215	Venturi - Natural Gas	1
562-150-292	Screw Pan Hd T20 M4x12 w/Square Cone Lock Washer	3
562-248-765	Washer .89 ID x 1.19 OD Garlock	1
590-318-102	O-Ring 3mm x 70mm Black	1
590-318-103	Gasket 1-Lips EPDM Ring 60 Dia MM	1
550-225-336	Label Gas Conversion	1
550-142-160	Instructions Conversion LP to Natural Gas	1

EVG 399 NG P/N 383-900-056 LP to Natural Gas Conversion Kit contents:		
511-050-216	Venturi - Natural Gas	1
562-150-292	Screw Pan Hd T20 M4x12 w/Square Cone Lock Washer	3
562-248-765	Washer .89 ID x 1.19 OD Garlock	1
590-318-102	O-Ring 3mm x 70mm Black	1
590-318-103	Gasket 1-Lips EPDM Ring 60 Dia MM	1
550-225-336	Label Gas Conversion	1
550-142-160	Instructions Conversion LP to Natural Gas	1

#### ▲WARNING

- Follow all instructions in proper order.
- Do not tamper with venturi. DO NOT change or modify venturi in any way.
- Dispose of an uninstalled venturi; do not leave in the building.
- Caution – the gas supply shall be shut off prior to disconnecting the electrical power, before proceeding with the conversion.
- Whenever the venturi is removed, all gaskets must be replaced with new gaskets.

#### Pipe sizing for propane gas

1. Contact gas supplier to size pipes, tanks and 100% lockup gas pressure regulator.

#### Natural and Propane supply pressure

1. Adjust propane supply regulator provided by gas supplier between the pressure listed below:
2. Pressure required at gas valve inlet pressure port:
  - a. Maximum: 14” (356 mm) w.c. with no flow (lockup).
  - b. Minimum gas pressure, with gas flowing (verify during boiler startup, while boiler is at high fire): 3½” (89 mm) w.c.

#### Installing propane venturi —

1. Propane venturi will have a black label identifying venturi part number. See [Figure 8, page 12](#) for correct part number.
2. Verify that the label on the propane venturi is correct for the model size (see [Figure 9](#) below).
3. If the jacket front door was not already removed, remove it.

**Figure 9** Propane gas venturi label identification (Black label)

Boiler Model	Part Number	Gas Type	Venturi Ø
EVG 220	511-050-236	LPG	30
EVG 299/300	511-050-220	LPG	34
EVG 399	511-050-221	LPG	38

**Figure 10** Natural gas venturi label identification (White label)

Boiler Model	Part Number	Gas Type	Venturi Ø
EVG 220	511-050-212	NG	30
EVG 299/300	511-050-215	NG	34
EVG 399	511-050-216	NG	38



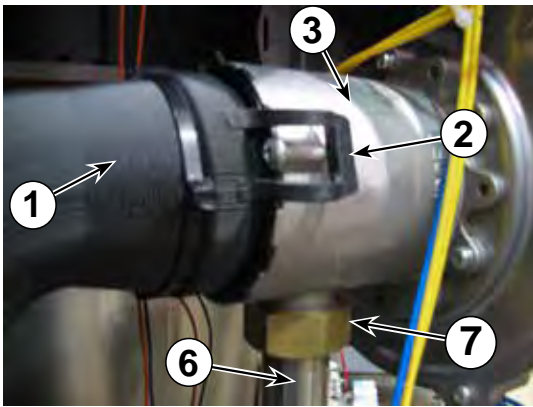
# Gas conversions *(continued)*

LEGEND for Figures 11, 12, 13 and 14			
1	Air Silencer	5	Gas valve
2	Air silencer clips (2)	6	Gas pipe
3	Venturi	7	Swivel nut
4	Blower	8	Fiber Washer

**WARNING** Use two wrenches when tightening gas piping at boiler, using one wrench to prevent the boiler gas line connection from turning. Failure to support the boiler gas connection pipe to prevent it from turning could damage gas line components.

4. Locate the blower and venturi (see Figure 11).
5. Gently pull on both silencer retaining clips (Figure 11, item 2) and remove air silencer from front of venturi (item 3).

**Figure 11** Air silencer removal

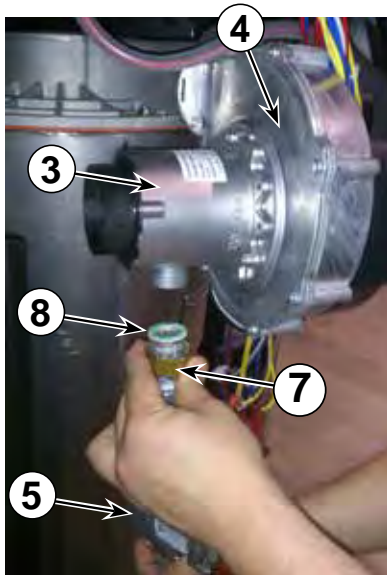


## Label wires before removing

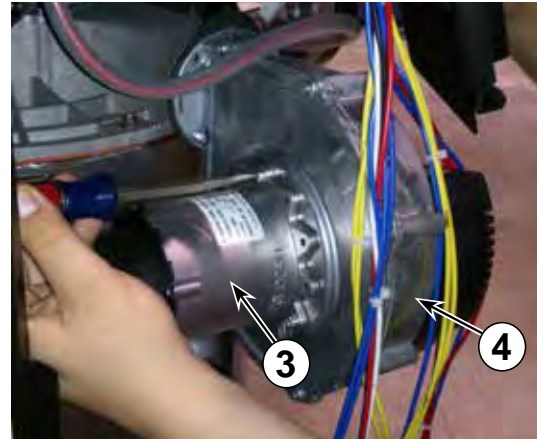
**CAUTION** Label all wires prior to disconnection when servicing controls. Wiring errors can cause improper and dangerous operation.

6. Disconnect wire harness from gas valve.
7. Loosen swivel nut (Figure 11, item 7) on venturi-gas valve connection (item 6). See Figure 12. Gently set gas valve a side.

**Figure 12** Gas pipe loosened for propane conversion

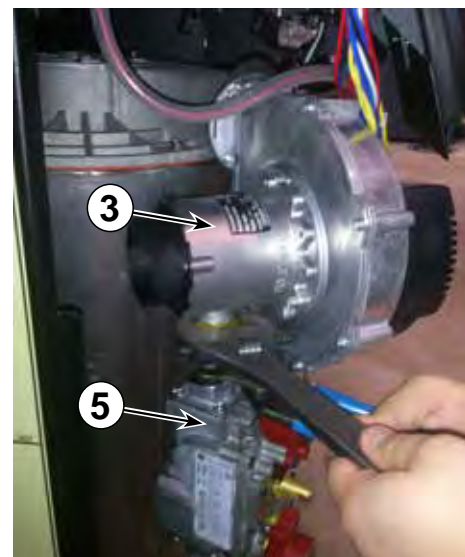


**Figure 13** Removal of Natural gas venturi



8. Remove three (3) T20 Torx screws holding the venturi, (Item 3) in place. Remove venturi, o-ring, and inspect blower surface. Discard old o-ring and fiber washer, see Figure 13.
9. Install new propane venturi and o-ring from conversion kit.
10. Ensure o-ring is seated properly in groove on blower.
11. Insert three (3) new Torx screws from conversion kit to hold venturi in place. Torque screws to no more than 23 inch-pounds.
12. Reassemble gas pipe with new fiber washer from conversion kit to the venturi connection, using two wrenches to tighten swivel nut. Replace silencer gasket and re-attach air silencer to venturi. See Figure 14.

**Figure 14** Installing the new propane gas venturi





# Gas conversions *(continued)*

**⚠ DANGER** Inspect the gas pipe fitting connections on the gas valve and new venturi (Item 3, [Figure 14, page 14](#)). Check the seal of the connections. Failure to comply will cause a gas leak, resulting in severe personal injury or death.

**⚠ WARNING** Do not check for gas leaks with an open flame — use bubble test. Failure to use bubble test or check for gas leaks can cause severe personal injury, death or substantial property damage.

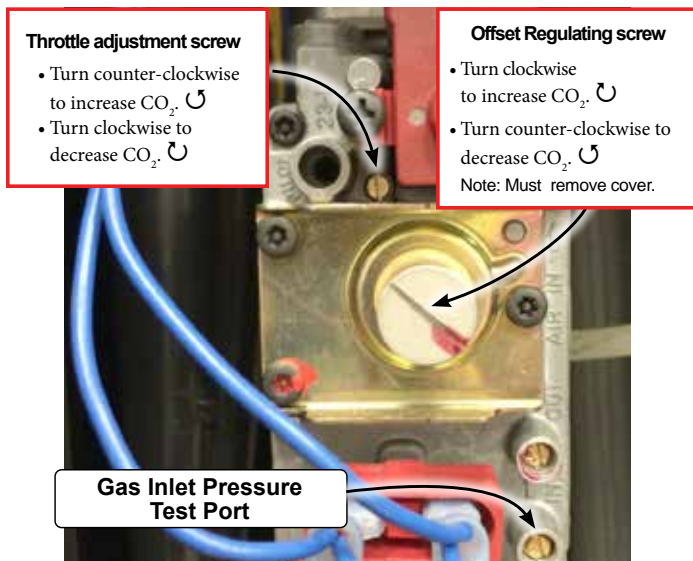
13. Prior to the boiler’s first ignition, adjust the throttle adjustment screw by first turning the screw clockwise (↻) until it bottoms out – do not apply any additional or excess torque. Adjust the throttle screw in a counterclockwise (↺) direction with precisely the number of turns listed in Table 1, according to the boiler model/size.

**Table 1:** Course adjustment settings—Throttle and offset adjustments to be made prior to first ignition, by size.

Boiler Model	Throttle Turns (Counterclockwise ↺ from Bottom-out Position)	Offset Turns (Counterclockwise ↺ Factory NG Position)
EVG 220 LP	5/8	3/4
EVG 299/300 LP	1-3/8	1/4
EVG 399 LP	1-5/8	1/4

14. After the throttle has been adjusted coarsely, the offset regulating screw must be adjusted. Remove the sealed, slotted cap protecting the white offset regulating screw before making adjustments. It is critical to be precise for the adjustment of

**Figure 15** Gas valve adjustment locations—ONLY for use by a qualified technician, using properly working, calibrated combustion test instruments.

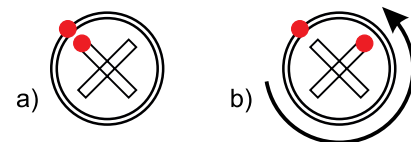


the offset regulating screw. DO NOT attempt to bottom out the offset regulating screw as was done for the throttle adjustment. Adjustments to the offset regulating screw should be made from the factory-provided natural gas position.

## Adjust the offset regulating screw using the following steps, referencing [Figure 16](#):

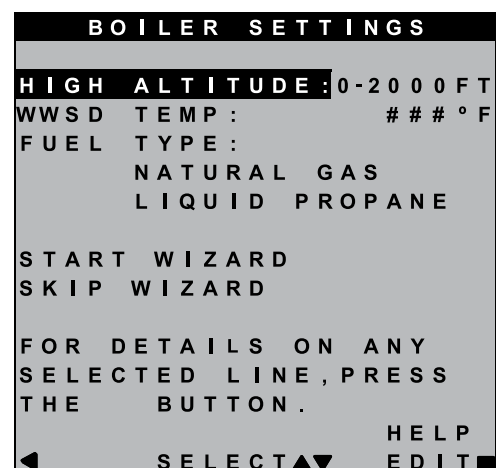
- 1a. Use a marker to mark the corner of one tip of the cross on the offset regulating screw and the corresponding location on the outside of the screw housing, as shown in [Figure 16a](#).
- 2b. Adjust the offset regulating screw in a counterclockwise (↺) direction with precisely the number of turns listed in Table 1, according to the boiler model/size.

**Figure 16** Offset regulating screw adjustment—(a) Marking factory-provided NG position. (b) View after 3/4 turn CCW adjustment.



15. Reconnect wire harness to gas valve.
16. Restore electrical power, turn on gas by opening manual gas valve and check for leaks.
17. When boiler has not been fired, follow instructions on the initial screens to select propane as the gas type. If natural gas was already selected in the boiler control, the gas type parameter will need to be adjusted. In the contractor menu, under the Boiler Settings menu, adjust the “LP Gas” setting to “YES”, see [Figure 75, page 76](#).
18. Before firing, verify that the Boiler Settings are for LP gas, “Max Rate” for the input (priority) used to fire the boiler

**Figure 17** Evergreen® fuel type setting screen





## Gas conversions *(continued)*

**Table 2:** Low-fire blower speeds—Minimum blower speed settings according to altitude settings.

Altitude Setting (ft.)	Lowest Rate for Altitude		
	220	299/300	399
0-2000	10%	10%	10%
2500	11%	11%	12%
3000	11%	11%	12%
3500	12%	11%	12%
4000	12%	12%	13%
4500	13%	12%	13%
5000	13%	12%	13%
5500	13%	13%	14%
6000	14%	13%	14%
6500	14%	13%	14%
7000	15%	14%	15%
7500	15%	14%	15%
8000	15%	14%	16%
8500	16%	14%	16%
9000	16%	15%	16%
9500	17%	15%	17%
10000	17%	15%	17%
10500	17%	16%	17%
11000	18%	16%	18%

is set between 96% and 100%. Also verify that the ‘Min Rate’ is set to 10% or the minimum rate allowed (if above 2000 ft. elevation). Adjust control settings if not at proper rate. Verify that boiler is operating at the expected firing rate at both high- and low-fire during combustion analysis. Refer to Table 2, [page 16](#) for proper low-fire rate based on altitude settings.

- Prior to turning on the boiler, review the procedure and control sequence for the operation of the [Manual Test Mode for Single and Multiple Boilers](#) starting on [page 101](#). The procedure differs between boilers set as a single or multiple-boiler unit.

**⚠ DANGER** The use of a flue gas analyzer is required to convert this unit and determine proper gas valve settings. Do not perform this conversion without a flue gas analyzer. Improper gas valve settings can cause severe personal injury, death, or property damage.

- Do NOT allow the boiler to modulate freely until the combustion analysis and adjustment is complete. Turn on and

connect properly working, calibrated combustion analyzer to the boiler flue pipe. Fire the boiler and force it to High Fire in Manual Test Mode. Adjust the high fire combustion first, using the throttle adjustment screw, to the CO<sub>2</sub> and CO ranges specified in [Figure 89, page 91](#), by model size. Then, force the boiler to Low Fire and adjust the offset regulating screw to the CO<sub>2</sub> and CO ranges specified in [Figure 89, page 91](#), by model size. Reinstall the slotted cap over the offset adjustment screw. Follow the full startup instructions found in this Boiler Manual including [Re-check the Maximum and Minimum CO<sub>2</sub> and CO rate](#).

- The coarse adjustment prescribed by this manual should result in combustion settings that allow for ignition and are a starting point for further adjustment. If, after making the coarse adjustments prescribed above, the boiler will not light, turn the throttle screw only counterclockwise (⤵) an additional 1/4 turn and attempt to light again. Repeat for a total of up to one full turn. If, after following the procedure above, the boiler still will not ignite or, during combustion analysis, the analyzer reads less than 1.0% O<sub>2</sub>, contact Weil-McLain Technical Services for assistance.
- Check for gas leaks and confirming proper performance.

### Perform Boiler Manual start-up

Perform complete start-up sequence (beginning on [page 86](#)), including check for gas leaks and checking for proper operation.

After placing the boiler in operation, the ignition system safety shutoff device must be tested, [page 91](#).

### Install front door

**⚠ WARNING** Install front door after servicing. The front door must be securely fastened to the boiler frame to prevent boiler from drawing air from inside the boiler room. This is particularly important if the boiler is located in the same room as other appliances. Failure to keep the door securely fastened could result in severe personal injury or death.

### Apply installer conversion label

- After installation is complete and boiler is set up for propane gas, fill out and attach the propane conversion label next to the boiler rating label (left side of cabinet).
- Contractor/installer is responsible for completing the information required on label (provided in kit) and attaching installer conversion label next to the boiler rating label.



# Gas conversions *(continued)*

**Figure 18** Installer conversion label

**NOTICE** THIS BOILER HAS BEEN CONVERTED TO PROPANE.

THIS MODEL \_\_\_\_\_ BOILER HAS BEEN CONVERTED  
 ON \_\_\_\_\_ (DATE OF CONVERSION) TO PROPANE GAS WITH A HIGH FIRE  
 % CO<sub>2</sub> OF \_\_\_\_\_ (% CO<sub>2</sub>)  
 BY \_\_\_\_\_ (NAME)  
 \_\_\_\_\_ (ADDRESS)

WHO ACCEPTS THE RESPONSIBILITY FOR THE CORRECTNESS OF THIS CONVERSION.

**NOTICE** MINIMUM AND MAXIMUM GAS PRESSURE, MANIFOLD PRESSURE AND INPUT RATINGS DO NOT CHANGE WITH THIS CONVERSION. REFER TO THE RATING LABEL FOR THIS INFORMATION.

**▲DANGER!** DO NOT PERFORM THIS CONVERSION WITHOUT A FLUE GAS ANALYZER. THE PROPER USE OF A FLUE GAS ANALYZER IS REQUIRED TO DETERMINE PROPER GAS VALVE SETTINGS. IMPROPER GAS VALVE SETTINGS CAN CAUSE SEVERE PERSONAL INJURY, DEATH OR PROPERTY DAMAGE. SEE BOILER INSTALLATION MANUAL FOR GAS VALVE ADJUSTMENT INFORMATION.

AFFIX THIS LABEL AS CLOSE AS POSSIBLE TO THE RATING LABEL.

550-225-336 (0309)

**Figure 19** Course adjustment settings—Throttle and offset adjustments to be made prior to first ignition, by size.

Boiler Model	Throttle Turns (Counterclockwise ↺ from Bottom-out Position)	Offset Turns (Clockwise ↻ Factory LP Position )
<b>EVG 220 NG</b>	1-5/8	3/8
<b>EVG 299/300 NG</b>	3-3/4	1/8
<b>EVG 399 NG</b>	3	1/8

**▲WARNING** The door must be in place during operation. DO NOT operate the boiler with the jacket door removed except for inspection and testing as directed in this manual.

## LP to Natural gas conversion

1. Follow the same instructions as LP conversion, except using the correct Natural gas conversion kit, See [Figure 8, page 12](#).
2. If LP gas was already selected in the boiler control, the gas type parameter will need to be adjusted. In the contractor menu, under the Boiler Settings menu, adjust the “LP Gas” setting to “NO”.
3. Turn throttle screw clockwise until it stops, and then turn counter-clockwise number of turns per [Figure 19](#). [Figure 19](#) is intended to make rough adjustment to gas valve to allow the boiler to fire. They are NOT intended to replace proper adjustment of combustion valves per instructions on [page 91](#) of this manual.
4. Adjust the offset regulating screw in a Clockwise direction the number of turns listed in [Figure 19](#), according to the boiler model/size.



# Gas piping — sizing gas lines

**NOTICE** Boiler gas connection is 3/4" NPT. Size gas lines large enough to provide gas to all connected appliances.

## Natural Gas:

### Pipe sizing for natural gas

1. Size gas piping from meter outlet to entrance of boiler in accordance with Figure 20 and Figure 21.
2. Use total input of all connected appliances. Divide total input in Btuh by 1,000 to obtain cubic feet per hour of natural gas.
  - a. Pipe lengths in Figure 20 are equivalent length of straight pipe. Convert pipe fittings to equivalent lengths using data from Figure 21.
  - b. Figure 20 is only for natural gas with specific gravity 0.60, with a pressure drop through the gas piping as listed in the table.
  - c. For additional gas pipe sizing information, refer to ANSI Z223.1 NFPA 54 - latest edition (or Natural Gas and Propane Installation CAN/CSA B149.1 or B149.2 for Canadian installations).

### Natural gas supply pressure

1. Pressure required at gas valve inlet pressure port:
  - a. Maximum: 14" (356 mm) w.c. with no flow (lockup).
  - b. Minimum gas pressure, with gas flowing (verify during boiler startup, while boiler is at high fire): 3 1/2" (89 mm) w.c.
2. Install 100% lockup gas pressure regulator in supply line if inlet pressure can exceed 14" w.c. at any time. Adjust lockup regulator for 14" w.c. maximum.

## Propane Gas:

**WARNING** You must follow the instructions, beginning on page 12, to operate the boiler on propane. Failure to comply could result in severe personal injury, death or substantial property damage.

### Pipe sizing for propane gas

1. Contact gas supplier to size pipes, tanks and 100% lockup gas pressure regulator.

### Propane supply pressure

1. Adjust propane supply regulator provided by gas supplier between the pressures listed below:
2. Pressure required at gas valve inlet pressure port:
  - a. Maximum: 14" (356 mm) w.c. with no flow (lockup).
  - b. Minimum gas pressure, with gas flowing (verify during boiler startup, while boiler is at high fire): 3 1/2" (89 mm) w.c.

**Figure 20** Pipe capacity for 0.60 specific gravity natural gas; pipe length is in equivalent feet (for non-corrugated pipe)

Gas pipe total length, feet	Capacity							
	Cubic feet per hour, natural gas, 0.60 specific gravity Gas pressure 14" (356 mm) w.c. or less Pressure drop 0.3 inches (7.6 mm) w.c.							
	3/4"	1"	1 1/4"	1 1/2"	2"	2 1/2"	3"	4"
10	278	520	1050	1600	3050	4800	8500	17500
20	190	350	730	1100	2100	3300	5900	12000
30	152	285	590	890	1650	2700	4700	9700
40	130	245	500	760	1450	2300	4100	8300
50	115	215	440	670	1270	2000	3600	7400
75	105	175	360	545	1020	1650	3000	6200
100	96	150	305	460	870	1400	2500	5100
150	90	120	250	380	710	1130	2000	4100

**Figure 21** Equivalent lengths of straight pipe for typical gas line fittings

Pipe size inches	Equivalent length, feet	
	90° Elbow	Tee
3/4	2.06	4.12
1	2.62	5.24
1 1/4	3.45	6.90
1 1/2	4.02	8.04
2	5.17	10.30
2 1/2	6.16	12.30
3	7.67	15.30
4	10.10	20.20



# Venting/air piping — general

**⚠ DANGER** Do not install the Evergreen® boiler into a common vent with any other appliance. This will cause flue gas spillage or appliance malfunction, resulting in possible severe personal injury, death or substantial property damage.

**⚠ WARNING** Existing common vent systems may be too large for the appliances remaining connected after the existing boiler is removed.

**⚠ WARNING** Failure to follow all instructions can result in flue gas spillage and carbon monoxide emissions, causing severe personal injury or death.

**⚠ WARNING** Use ONLY the venting materials and venting manufacturers' components and systems approved by Weil-McLain. Follow all instructions provided by the venting component and system manufacturer. Failure to do so can cause flue gas spillage and carbon monoxide emissions, resulting in severe personal injury or death.

## Replacing a boiler from an existing common vent system

The Evergreen® boiler cannot be common vented with any other appliance. When an existing boiler is replaced with an Evergreen® boiler, the Evergreen® boiler CANNOT use the existing common vent. The Evergreen® boiler requires its own vent and air piping, as specified in this manual. This may cause a problem for the appliances that remain on the original common vent, because the vent may be too large.

Perform the test sequence below for **each** appliance remaining on the original common vent system. Operate each appliance individually with other appliances turned off. This procedure will test whether the common vent system can properly vent each appliance.

### Existing vent test procedure

*(The following is intended to test whether the appliances remaining on an existing vent system will operate satisfactorily.)*

1. Seal any unused openings in the common venting system.
2. Visually inspect the venting system for proper size and horizontal pitch and determine there is no blockage or restriction, leakage, corrosion or other deficiencies which could cause an unsafe condition.
3. Test vent system — Insofar as is practical, close all building doors and windows and all doors between the space in which the appliances remaining connected to the common venting system are located and other spaces of the building. Turn on clothes dryers and any appliance not connected to the common venting system. Turn on any exhaust fans, such as range hoods and bathroom exhausts, so they will operate at maximum speed. Do not operate a summer exhaust fan. Close fireplace dampers.
4. Place in operation the appliance being inspected. Follow the lighting instructions. Adjust thermostat so appliance will operate continuously.
5. Test for spillage at draft hood relief opening after 5 minutes of main burner operation. Use the flame of a match or candle, or smoke from a cigarette, cigar, or pipe.
6. After it has been determined that each appliance remaining connected to the common venting system properly vents when tested as outlined herein, return doors, windows, exhaust fans, fireplace dampers, and any other gas-burning appliance to their previous conditions of use.

Any improper operation of common venting system should be corrected so the installation conforms with the National Fuel Gas Code, ANSI Z223.1/NFPA 54 — latest edition. Correct by re-sizing to approach the minimum size as determined using the appropriate tables in Part 13 of that code. Canadian installations must comply with Natural Gas and Propane Installation Code, CAN/CSA B149.1 or B149.2.

**⚠ WARNING** You must pipe combustion air to the boiler air intake.

Install air inlet piping for the Evergreen® boiler as described in this manual.

The air termination fitting must be installed with the clearances and geometry relative to the vent outlet depicted in this manual to ensure that flue products do not enter the air intake.

Ensure that the combustion air will not contain any of the contaminants in Figure 22. Do not pipe combustion air near a swimming pool, for example. Avoid areas subject to exhaust fumes from laundry facilities. These areas will always contain contaminants.

Contaminated combustion air will damage the boiler, resulting in possible severe personal injury, death or substantial property damage.

**Figure 22** Corrosive contaminants and sources

Products to avoid
Spray cans containing chloro/fluorocarbons
Permanent wave solutions
Chlorinated waxes/cleaners
Chlorine-based swimming pool chemicals
Calcium chloride used for thawing
Sodium chloride used for water softening
Refrigerant leaks
Paint or varnish removers
Hydrochloric acid/muriatic acid
Cements and glues
Antistatic fabric softeners used in clothes dryers
Chlorine-type bleaches, detergents, and cleaning solvents found in household laundry rooms
Adhesives used to fasten building products and other similar products
Excessive dust and dirt

Areas likely to have contaminants
Dry cleaning/laundry areas and establishments
Swimming pools
Metal fabrication plants
Beauty shops
Refrigeration repair shops
Photo processing plants
Auto body shops
Plastic manufacturing plants
Furniture refinishing areas and establishments
New building construction
Remodeling areas
Garages with workshops
Buildings under construction (where air is contaminated with particulates)



# Venting & air — general *(continued)*

**Figure 23 Evergreen<sup>®</sup> venting and air piping — DIRECT VENT ONLY — OPTIONS and PIPING LIMITS**

**NOTICE**



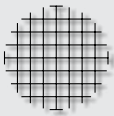
The table below lists the acceptable vent/air pipe terminations described in this manual. Follow all instructions provided to install the vent/air system. **NOT SHOWN** below, but also approved, are the polypropylene piping and terminations listed in [Figure 24, page 21](#). For these applications, use **ONLY** the manufacturers' parts listed and follow all instructions provided by the pipe manufacturer.

Evergreen <sup>®</sup> Model	Maximum vent and air pipe length = 100 feet for all applications (Minimum length for all applications is 2 feet equivalent plus termination) <small>(All applications include allowance for the termination fittings plus one elbow in air piping and one elbow in vent piping).</small>										USE SWEEP ELBOWS ONLY	
	See <a href="#">Figure 24, page 21</a> for material specifications   See <a href="#">Figure 111, page 117</a> for part/kits numbers											
	Vent and air pipe sizes: Maximum vent lengths apply for either 3" or 4" vent and air pipe. If using 3" pipe, provide 4"x 3" tapered reducers at boiler connections and at Weil-McLain vent/air cap or at concentric terminations. Boilers will derate as vent/air pipe length increases — see rating data on <a href="#">Figure 123, page 129</a> for derate amounts.											
	SIDEWALL termination						VERTICAL termination					
	Separate pipes [Note 1]		Weil-McLain vent/air plate [Note 1 & 2]		PVC Concentric [Note 1 & 2]		Separate pipes [Note 1]		PVC or PP Concentric [Note 1 & 2]		Vertical vent/Sidewall air [Note 1]	
	See <a href="#">page 25</a>		See <a href="#">page 27</a>		See <a href="#">page 29</a>		See <a href="#">page 31</a>		See <a href="#">page 33</a>		See <a href="#">page 36</a>	
Size, inches	Materials <a href="#">page 21</a>	Size, inches	Materials <a href="#">page 21</a>	Size, inches	Materials <a href="#">page 21</a>	Size, inches	Materials <a href="#">page 21</a>	Size, inches	Materials <a href="#">page 21</a>	Size, inches	Materials <a href="#">page 21</a>	
220	3	PVC/PVC-DWV CPVC, PP, SS	3	PVC/PVC-DWV CPVC, PP	3	PVC/PVC-DWV CPVC	3	PVC/PVC-DWV CPVC, PP, SS	3	PVC/PVC-DWV CPVC, PP	3	PVC/PVC-DWV CPVC, PP, SS
	4	PVC/PVC-DWV CPVC, PP, SS	4	PVC/PVC-DWV CPVC, PP	4	PVC/PVC-DWV CPVC	4	PVC/PVC-DWV CPVC, PP, SS	4	PVC/PVC-DWV CPVC, PP	4	PVC/PVC-DWV CPVC, PP, SS
299/300	4	PVC/PVC-DWV CPVC, PP, SS	4	PVC/PVC-DWV CPVC, PP	4	PVC/PVC-DWV CPVC	4	PVC/PVC-DWV CPVC, PP, SS	4	PVC/PVC-DWV CPVC, PP	4	PVC/PVC-DWV CPVC, PP, SS
399	4	PVC/PVC-DWV CPVC, PP, SS	4	PVC/PVC-DWV CPVC, PP	4	PVC/PVC-DWV CPVC	4	PVC/PVC-DWV CPVC, PP, SS	4	PVC/PVC-DWV CPVC, PP	4	PVC/PVC-DWV CPVC, PP, SS
<p><b>WARNING</b> All elbows in vent and air piping must be sweep elbows ONLY. DO NOT use short-radius elbows. When transitioning to 4-inch to 3-inch, use tapered reducer with 4" PVC nipple (l ≥ 6"). Do not use 4-inch to 3-inch bushing. Bushing will Not seal in boiler adapter.</p>												
<p><b>Equivalent feet for elbows (USE SWEEP ELBOWS ONLY)</b> — deduct from max. equivalent length of piping (does not apply to termination fittings).  <b>PVC</b> • 7 feet per for each additional 90° sweep elbow or 45° elbow — If piping contains more than 1 elbow in air or vent piping, other than termination fittings.  <b>PP</b> • Centrotherm 3" = 6'                      4" = 20'                      Duravent 3" = 17'                      4" = 22'</p>												
Note 1	<p>Material abbreviations: PP = polypropylene, SS = AL29-4C stainless steel                      If using polypropylene or stainless pipe, provide adapters for 4" boiler connections and for terminations, if required IPEX PVC concentric vent kits can be used with standard PVC pipe, fittings and cement (ANSI/ASTM D1785) except if ULC S636 compliance is required. For ULC S636 compliance, all pipe, fittings and cement must be IPEX System 636. For UL 1738 compliance all pipe, fittings and cement must be IPEX System 1738. If using IPEX kits, use only IPEX product code listed in <a href="#">Figure 111, page 117</a>. Contact Weil-McLain for ordering information and availability of Weil-McLain venting kits.</p>											
Note 2	<p>Use only Weil-McLain approved termination kits listed in <a href="#">Figure 111, page 117</a>.</p>											



# Venting & air — general *(continued)*

**Figure 24 Vent and air piping materials** — Use only the materials listed below, ensuring that all materials meet local codes (see [Figure 111](#), [page 117](#) for part/kit numbers)

Item	Material	Standards for installations in:		
		United States	Canada (Note 2)	
<b>Plastic piping materials</b>		<b>Vent or air piping</b>	<b>Vent piping</b>	<b>Air piping</b>
<b>Vent or air pipe &amp; fittings</b>	PVC schedule 40 (Note 1)	ANSI/ASTM D1785/UL1738/ULC S636	ULC S636	PVC, PVC-DWV, CPVC or polypropylene
	PVC-DWV schedule 40 (Note 1)	ANSI/ASTM D2665	N/A	
	CPVC schedule 40 (Note 1)	ANSI/ASTM F441 / ULC S636	ULC S636	
<b>PVC &amp; ABS pipe cement &amp; primer</b>	PVC (Note 1)	ANSI/ASTM D2564 / F656 / UL1738	ULC S636	Use only cement and primer suitable for piping material used
	CPVC (Note 1)	ANSI/ASTM F493	ULC S636	
	CPVC to PVC transition	Use only cement and primer suitable for piping material used	ULC S636	
<b>Polypropylene vent pipe, fittings, terminations and cement</b>	<b>Simpson-Duravent</b> — Obtain all materials from M&G Simpson-Duravent <b>Centrotherm Eco Systems InnoFlue® Single-wall</b> — Obtain all materials from Centrotherm (Note: See <a href="#">page 117</a> for correct appliance adapters to be used.)	See manufacturer's literature for detailed information <b>MUST USE LOCKING COLLAR ON EVERY JOINT</b>	ULC S636	PVC, PVC-DWV, CPVC or polypropylene
<b>AL29-4C stainless steel piping materials</b>				
<b>Vent pipe AL29-4C stainless steel</b>	Heat Fab, Inc. — Saf-T-Vent® Z-Flex, Inc. — Z-Vent Dura-Vent — FasNSeal™ Metal-Fab, Inc. — CORR/GUARD	Certified for Category IV and direct vent appliance venting	Certified for Category IV and direct vent appliance venting	
<b>Weil-McLain stainless steel bird screens, 3" or 4" (purchase separately)</b> — see <a href="#">Figure 111</a> , <a href="#">page 117</a> for part numbers				
Note 1:	Weil-McLain concentric vent kits are made from PVC pipe and fittings.	<b>⚠ WARNING</b> ADAPTERS — AL29-4C piping — Install a PVC-to-stainless adapter supplied by the AL29-4C stainless pipe manufacturer at the 4" PVC boiler vent connection. Can not be used with Weil-McLain termination plate or concentric termination.  ADAPTERS — Polypropylene piping — Provide adapters from polypropylene pipe to the 4" PVC connections at the boiler and at terminations, if required (Weil-McLain sidewall plate, for example).  ADAPTERS — If using 3" piping, where approved for the application, provide adapters for the 4" PVC boiler connections and at the terminations, if required (Weil-McLain sidewall plate, for example).		
Note 2:	System 636 PVC concentric terminations utilize PVC pipe/fittings certified to ULC S636. If ULC S636 compliance is required, use only System 636 pipe, fittings and cement. If UL1738 compliance is required, use only System 1738 pipe, fittings and cement.			
<b>⚠ WARNING</b>	DO NOT mix piping from different pipe manufacturers unless using adapters specifically designed for the purpose by the manufacturer.			
<b>⚠ WARNING</b>	Every joint on <b>polypropylene vent piping</b> must include a locking collar.			
<b>⚠ WARNING</b>	DO NOT use cellular core PVC (ASTM F891), cellular core CPVC, or Radel® (polyphenolsulfone) in venting systems.			
<b>⚠ WARNING</b>	DO NOT cover non-metallic vent pipe and fittings with thermal insulation.			
		<b>⚠ WARNING</b>	For PVC — <b>USE SWEEP ELBOWS FOR ALL VENT AND AIR PIPING</b> — DO NOT use short radius elbows for vent or air piping. Boiler performance could be affected.	
	<b>⚠ WARNING</b>	<b>ALL</b> vent and air pipes require a <b>BIRD SCREEN at each termination</b> . Most kits do not include the bird screens. Purchase bird screens separately from Weil-McLain or vent kit supplier if not included. [Note — bird screening is integral to the 3" and 4" PVC Weil-McLain sidewall vent cap, purchased separately. No additional screening is required.]		



# Commonwealth of Massachusetts installations

**Commonwealth of Massachusetts** — When the boiler is installed within the Commonwealth of Massachusetts, the boiler must be installed by a licensed plumber or gas fitter. Read and comply with the instructions below.

- (a) **REQUIREMENTS:** For all sidewall horizontally-vented gas-fueled equipment installed in every dwelling, building or structure used in whole or in part for residential purposes, including those owned or operated by the Commonwealth and where the side wall exhaust vent termination is less than seven (7) feet above finished grade in the area of the venting, including but not limited to decks and porches, the following requirements shall be satisfied:
1. **INSTALLATION OF CARBON MONOXIDE DETECTORS.** At the time of installation of the side wall horizontal vented gas fueled equipment, the installing plumber or gas fitter shall observe that a hard wired carbon monoxide detector with an alarm and battery back-up is installed on the floor level where the gas equipment is to be installed. In addition, the installing plumber or gas fitter shall observe that a battery operated or hard wired carbon monoxide detector with an alarm is installed on each additional level of the dwelling, building or structure served by the side wall horizontal vented gas fueled equipment. It shall be the responsibility of the property owner to secure the services of qualified licensed professionals for the installation of hard wired carbon monoxide detectors.
    - a. In the event that the side wall horizontally vented gas fueled equipment is installed in a crawl space or an attic, the hard wired carbon monoxide detector with alarm and battery back-up may be installed on the next adjacent floor level.
    - b. In the event that the requirements of this subdivision can not be met at the time of completion of installation, the owner shall have a period of thirty (30) days to comply with the above requirements; provided, however, that during said thirty (30) day period, a battery operated carbon monoxide detector with an alarm shall be installed.
  2. **APPROVED CARBON MONOXIDE DETECTORS.** Each carbon monoxide detector as required in accordance with the above provisions shall comply with NFPA 720 and be ANSI/UL 2034 listed and IAS certified.
  3. **SIGNAGE.** A metal or plastic identification plate shall be permanently mounted to the exterior of the building at a minimum height of eight (8) feet above grade directly in line with the exhaust vent terminal for the horizontally vented gas fueled heating appliance or equipment. The sign shall read, in print size no less than one-half (1/2) inch in size, “GAS VENT DIRECTLY BELOW. KEEP CLEAR OF ALL OBSTRUCTIONS.”
  4. **INSPECTION.** The state or local gas inspector of the side wall horizontally vented gas fueled equipment shall not approve the installation unless, upon inspection, the inspector observes carbon monoxide detectors and signage installed in accordance with the provisions of 248 CMR 5.08(2)(a) 1 through 4.
- (b) **EXEMPTIONS:** The following equipment is exempt from 248 CMR 5.08(2)(a)1 through 4:
1. The equipment listed in Chapter 10 entitled “Equipment Not Required To Be Vented” in the most current edition of NFPA 54 as adopted by the Board; and
  2. Product Approved side wall horizontally vented gas fueled equipment installed in a room or structure separate from the dwelling, building or structure used in whole or in part for residential purposes.
- (c) **MANUFACTURER REQUIREMENTS — GAS EQUIPMENT VENTING SYSTEM PROVIDED.** When the manufacturer of Product Approved side wall horizontally vented gas equipment provides a venting system design or venting system components with the equipment, the instructions provided by the manufacturer for installation of the equipment and the venting system shall include:
1. Detailed instructions for the installation of the venting system design or the venting system components; and
  2. A complete parts list for the venting system design or venting system.
- (d) **MANUFACTURER REQUIREMENTS — GAS EQUIPMENT VENTING SYSTEM NOT PROVIDED.** When the manufacturer of a Product Approved side wall horizontally vented gas fueled equipment does not provide the parts for venting the flue gases, but identifies “special venting systems”, the following requirements shall be satisfied by the manufacturer:
1. The referenced “special venting system” instructions shall be included with the appliance or equipment installation instructions; and
  2. The “special venting systems” shall be Product Approved by the Board, and the instructions for that system shall include a parts list and detailed installation instructions.
- (e) **PLASTIC VENTING SYSTEMS.**  
The only plastic piping which may be used for venting appliances shall be:
1. Allowed by the appliance manufacturer.
  2. Listed to a national/international standard for plastic venting systems.
  3. Product-accepted for that purpose by the board.
- (f) **INSTALLATION INSTRUCTIONS.** A copy of all installation instructions for all Product Approved side wall horizontally vented gas fueled equipment, all venting instructions, all parts lists for venting instructions, and/or all venting design instructions shall remain with the appliance or equipment at the completion of the installation.



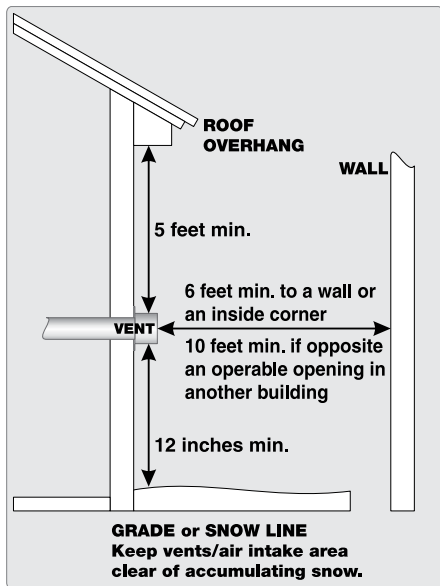
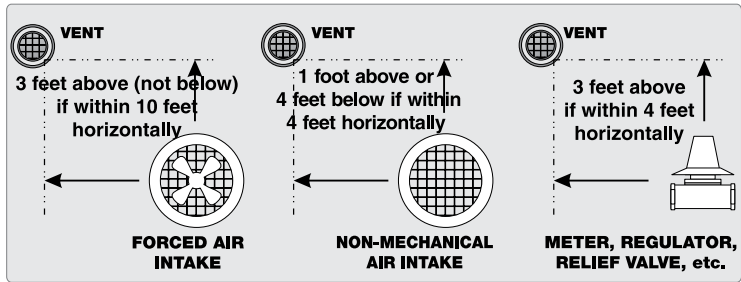
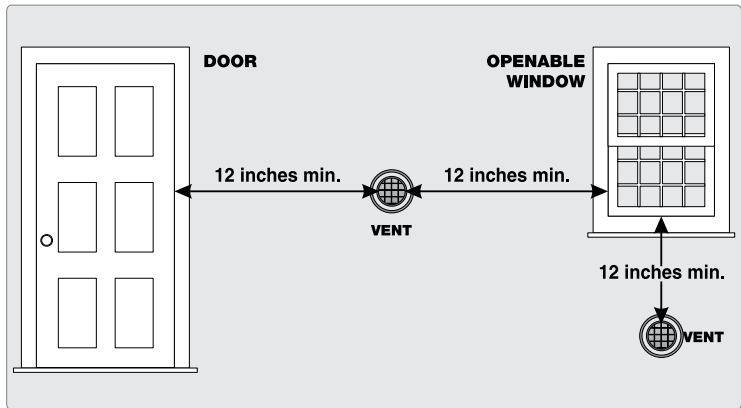
# Vent termination requirements

**Figure 25** The vent termination must be located to meet all requirements below (also applies to vertical vent terminations). The minimum distance from adjacent public walkways, adjacent buildings, openable windows and building in the National Fuel Gas Code, ANSI Z223.1/NFPA 54 and/or the Natural Gas and Propane Installation Code, CAN/CSA B149.1. The vent termination clearances below are for U.S.A., for Canadian vent termination clearances please refer to the requirements of CAN/CSA B149.1 Natural Gas and Propane Installation Code. Consideration should be given to avoid possible damage caused by vent plumes and condensate when choosing a venting configuration and location. Maintain a minimum clearance of 4 ft. (1.22 m) horizontally from, and in no case above or below, unless a 4 ft. (1.22m) horizontal distance is maintained, from electrical meters, gas meters, regulators, and relief equipment.

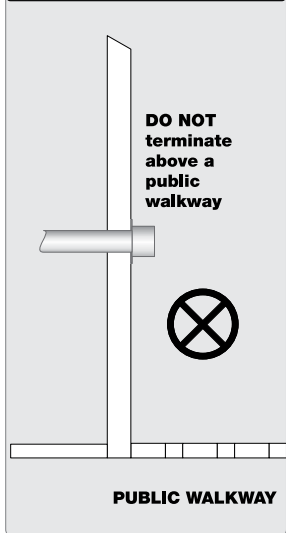


WH-026

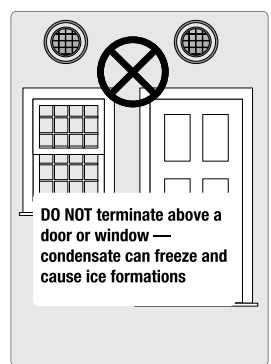
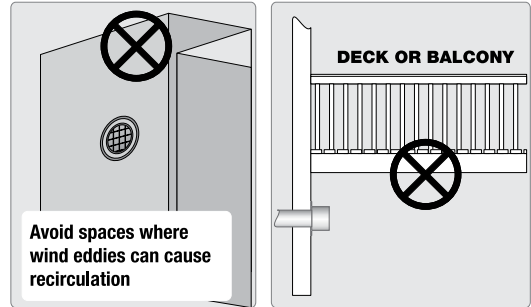
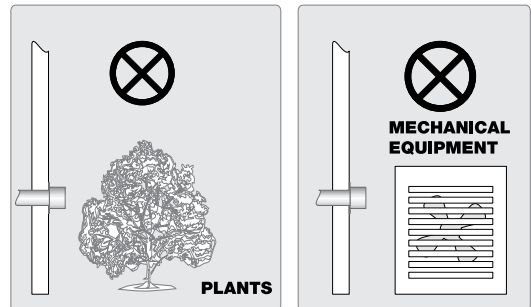
## MINIMUM CLEARANCES



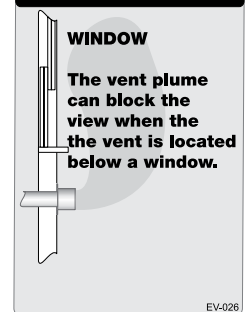
## DO NOT TERMINATE:



## DO NOT TERMINATE:



## CONSIDER



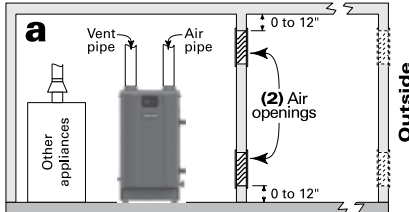
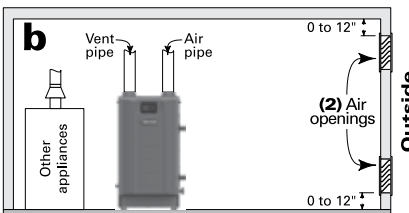
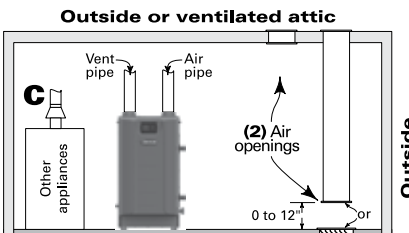
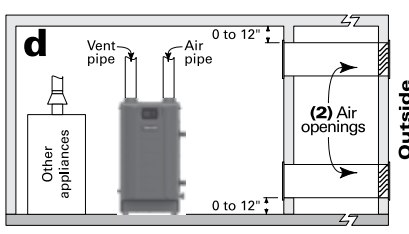
EV-026



# Boiler room air openings

**Figure 26** Combustion and ventilation air openings for Evergreen<sup>®</sup> Direct Vent installations. Provisions for combustion and ventilation air to be in accordance with the section “Air for Combustion and Ventilation,” of the National Fuel Gas Code, ANSI Z223.1/NFPA 54, or applicable provisions of the local building codes.

**WARNING** The Evergreen<sup>®</sup> boiler CANNOT be in the same space with other appliances if clearances around the Evergreen<sup>®</sup> are less than the recommended service clearances shown in Figure 1, page 7.

<p><b>Air openings</b></p> <p>The required air opening sizes below are FREE AREA, after reduction for louver obstruction. Note the exception below for large spaces.</p>	<p><b>Evergreen<sup>®</sup> boiler WITH other appliances in room</b></p>	<p><b>Evergreen<sup>®</sup> boiler WITHOUT other appliances in room</b></p>
	<p><b>TWO</b> openings, each at least: <b>1 square inch per 1,000 Btuh</b> of all other appliances in the room (Unless specified otherwise by appliance manufacturer)</p>	
	<p><b>TWO</b> openings, each at least: <b>1 square inch per 4,000 Btuh</b> of all other appliances in the room — OR — <b>ONE</b> opening **, each at least: <b>1 square inch per 3,000 Btuh</b> of all other appliances in the room (Unless specified otherwise by appliance manufacturer)</p>	<p><b>NO</b> openings are required if the boiler installation provides at least the recommended service clearances shown in Figure 1, page 7.</p>
<p><b>Outside or ventilated attic</b></p> 	<p><b>TWO</b> openings, each at least: <b>1 square inch per 4,000 Btuh</b> of all other appliances in the room — OR — <b>ONE</b> opening **, each at least: <b>1 square inch per 3,000 Btuh</b> of all other appliances in the room (Unless specified otherwise by appliance manufacturer)</p>	<p><b>If the space is smaller than Figure 1, page 7, provide openings ONLY as shown in Figure 2, page 7.</b> Each opening must have a free area no less than 1 square inch per 1,000 Btuh input of the boiler.</p>
	<p><b>TWO</b> openings, each at least: <b>1 square inch per 2,000 Btuh</b> of all other appliances in the room — OR — <b>ONE</b> opening **, each at least: <b>1 square inch per 3,000 Btuh</b> of all other appliances in the room (Unless specified otherwise by appliance manufacturer)</p>	
<p><b>** NOTICE:</b></p> <p><b>Requirements for using the SINGLE air opening option.</b></p>	<p>A single combustion air opening can be used for cases b, c, or d above (Evergreen<sup>®</sup> with other appliances in room only), sized as listed, provided that:</p> <ul style="list-style-type: none"> <li>• The single opening must communicate directly to the outdoors or to a space that communicates directly with outdoors (NOT to an interior space).</li> <li>• The top of the opening must be within 12 inches of the ceiling.</li> <li>• The free area of the opening must be at least equal to the sum of the areas of all equipment vent connectors in the space.</li> </ul>	
<p><b>SPECIAL EXCEPTION FOR LARGE SPACES (Evergreen WITH other appliances in room only):</b></p>	<p>NO combustion air openings are needed if the boiler (and other appliances) are installed in a space with a volume NO LESS than 50 cubic feet per 1,000 Btuh of all appliances in the space. That is, total the input of all appliances in MBH (1,000's of Btuh), then multiply this total times 50. The building MUST NOT be of tight construction.</p> <p>Example: For a total input of 500 MBH (500,000 Btuh), the minimum volume would be 50 x 500 = 25,000 cubic feet.</p>	



# DIRECT VENT — Sidewall with separate pipes

## Allowable vent/air pipe materials & lengths

**▲WARNING** Use only the vent materials and kits listed in Figure 24, page 21. Provide pipe adapters if specified.

1. Locate the termination such that the total air piping and vent piping from the boiler to the termination will not exceed the maximum length given in Figure 23, page 20.

**Polypropylene** For polypropylene applications, comply with any additional requirements in the vent system manufacturer's instructions. Provide 4" PVC-to-PP transition pieces at the boiler vent and air connections. PP adapter must have smooth, straight section of pipe to insert in to the boiler vent and air connections and must fit and seal tightly. PP adapters with their own seal which would interfere with the internal seal of the boiler vent or air connections must not be used. Refer to page 117 for a list of compliant adapters. Install a locking collar at every joint.

**AL29-4C S.S.** For AL29-4C vent pipe applications, comply with any additional requirements in the vent system manufacturer's instructions. Provide a 4" PVC transition piece at the boiler vent connection. The air piping must be PVC or CPVC. Provide a 4" PVC transition piece at the boiler air connection if using 3" air piping.

2. For 4" to 3" transitions, must use appropriate vent material. For polypropylene or stainless steel must use approved suppliers transitions (EVG 220 only).

## Determine termination location

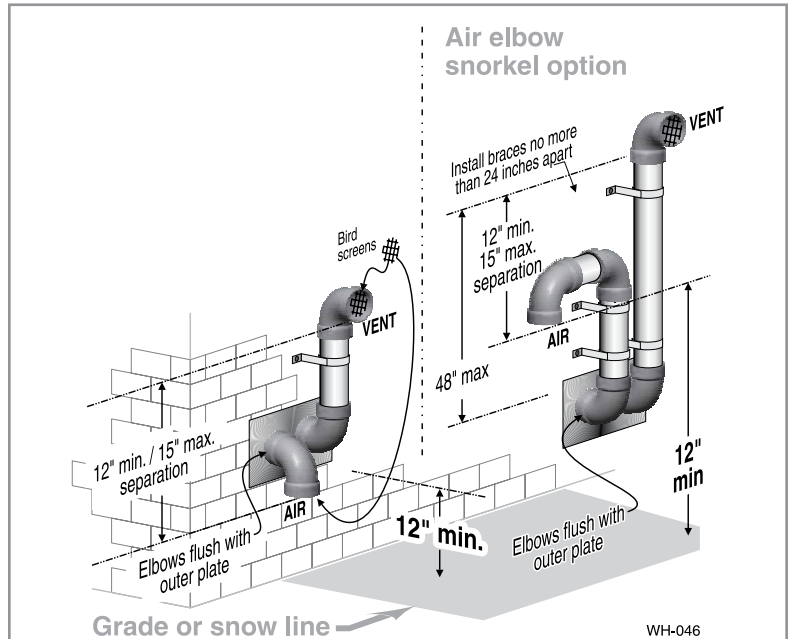
1. Wall penetration thickness between 0" to 24".
2. The air and vent terminations must be installed as shown in Figure 27 and Figure 29, page 26.
3. The terminations must comply with clearances and limitations shown in Figure 25, page 23.
4. Locate the terminations so they are not likely to be damaged by foreign objects, such as stones or balls, or subject to buildup of leaves or sediment.

**▲WARNING** Do not exceed the maximum lengths of the outside vent piping shown in Figure 27. Excessive length exposed to the outside could cause freezing of condensate in the vent pipe, resulting in potential boiler shut down. In extremely cold climates, install an insulated chase around the vent piping, particularly if using longer lengths. The chase must allow for inspection of the vent pipe, and insulation must be protected from water.

## Multiple vent/air terminations

1. When terminating multiple Evergreen® boilers, terminate each vent/air connection as described in this manual.

Figure 27 INSTALLATION SEQUENCE — Separate pipes sidewall



- Step 1** Read and follow all instructions in this manual. **DO NOT proceed with vent/air installation until you have read page 19 through page 24.** **Polypropylene AL29-4C S.S.** See notices at left.
- Step 2** Install the boiler in a location that allows proper routing of all vent and air piping to the selected sidewall location.
- Step 3** Make sure the selected sidewall termination location complies with Figure 25, page 23. (Multiple boiler sidewall plates must also comply with Figure 28, page 26.)
- Step 4** Use only the vent materials listed in Figure 24, page 21. Provide pipe adapters where required. Vent piping and air piping lengths must not exceed the values shown in Figure 23, page 20.
- Step 5** Prepare the sidewall penetrations and secure the sidewall plates as instructed in this section. See "Prepare wall penetrations" on page 26. **Polypropylene AL29-4C S.S.** See notices at left.
- Step 6** The air piping must terminate in a **down-turned elbow** as shown above. The vent piping must terminate in an **elbow pointed outward or away from the air inlet** as shown above. See illustration above.
- Step 7** Install vent and air piping between the boiler and the sidewall openings. Slope horizontal piping downward toward the boiler at least 1/4 inch per foot. See page 38 for general guidelines. **Polypropylene AL29-4C S.S.** See notices at left.
- Step 8** Install pipe supports every 5 feet on both the horizontal and vertical runs. Install a hanger support within 6 inches of any upturn in the piping, or per vent pipe manufacturer's instructions. **Polypropylene AL29-4C S.S.** See notices at left.
- Step 9** Attach the vent termination exterior piping: Use either of the configurations shown above, as needed to ensure clearance above grade or snow line. Keep vents/air intake area clear of accumulating snow.
- Step 10** The vent and air pipes may run up as high as 4 feet with no enclosure. The vent and air pipes must be secured with braces, and all clearances and lengths must be maintained. Space braces no further than 24 inches apart.
- Step 11** External venting greater than 4 feet requires an insulated enclosure around the vent and air pipes. The vent and air terminations must exit through the enclosure as shown in the illustration above, maintaining all required clearances.



**▲WARNING** **USE SWEEP ELBOWS FOR ALL VENT AND AIR PIPING** — DO NOT use short radius elbows for vent or air piping. Boiler performance could be affected.



# DIRECT VENT — Sidewall with separate pipes *(continued)*

Polypropylene AL29-4C S.S. See notices on previous page.

**WARNING** All vent pipes and air inlets must terminate at the same height to avoid possibility of severe personal injury, death or substantial property damage.

2. Place wall penetrations to obtain minimum clearances shown in Figure 28 for U. S. installations. For Canadian installations, provide clearances required by Natural Gas and Propane Installation Code, CAN/CSA B149.1 or B149.2 and a ULC S636 compliant vent kit.
3. The air inlet of a Evergreen<sup>®</sup> boiler is part of a direct vent connection. It is not classified as a forced air intake with regard to spacing from adjacent boiler vents.

## Prepare wall penetrations

1. Air pipe penetration:
  - a. Cut a hole for the air pipe. Size the air pipe hole as close as desired to the air pipe outside diameter.
2. Vent pipe penetration:
  - a. Cut a hole for the vent pipe. For either combustible or non-combustible construction, size the vent pipe hole at least 0.4” larger than the vent pipe diameter.
  - b. Insert a galvanized metal thimble in the vent pipe hole as shown in Figure 29.
3. Use the provided paper template for correct location of hole centers.
4. Use of a sidewall termination plate is REQUIRED.
  - a. Kits for several vent sizes are available from Weil-McLain. See “VENT/AIR PARTS AND KITS” on page 117.
  - b. Plate may be field fabricated from corrosion resistant material of sufficient strength. Plate must allow venting to maintain minimum clearance to combustibles.

**WARNING** Ensure that the plate material is strong enough to prevent the termination from being pushed inward if struck or pushed from the outside.

5. Follow all local codes for isolation of vent pipe when passing through floors or walls.
6. Seal exterior openings thoroughly with exterior caulk.

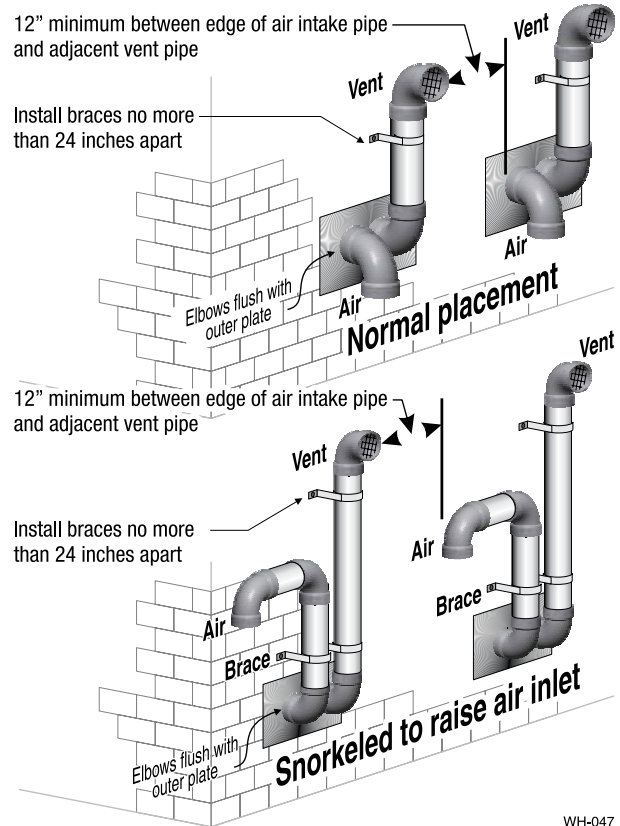
## Termination and fittings

1. Prepare the vent termination elbow and the air termination elbow by inserting bird screens. (See Figure 27, page 25.) Bird screens must be purchased separately. See the parts list at the end of this manual for part numbers.
2. When completed, the air termination coupling must be oriented at least 12 inches below the vent termination and at least 12 inches above grade or snow line as shown in Figure 27, page 25.
3. Orient the vent termination elbow directly outward as shown in Figure 27, page 25.
4. Maintain the required dimensions of the finished termination piping as shown in Figure 27, page 25.
5. For multiple boiler terminations, see Figure 28.
6. Do not extend exposed vent pipe outside of building more than shown in this document. Condensate could freeze and block vent pipe.

**NOTICE** If extending the vent and air pipes out from the wall, install a coupling on each pipe. Mount the piping with the coupling flush with the outer plate.

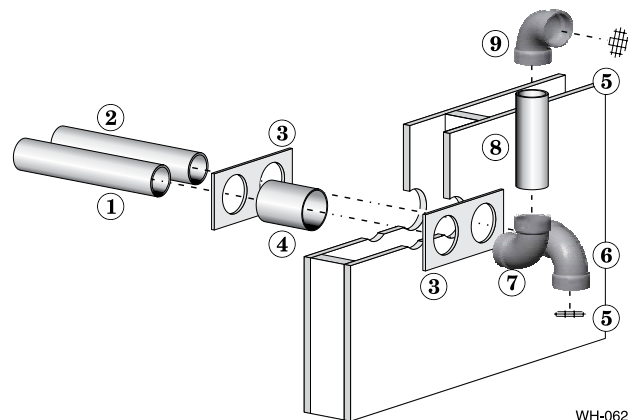
**NOTICE** Wall penetration thickness between 0” to 24”.

**Figure 28** Multiple separate pipes sidewall terminations — maintain vertical spacing between vent and air fittings shown in Figure 27, page 25.



WH-047

**Figure 29** Sidewall termination assembly — using separate pipes



WH-062

- |  |                                     |
|--|-------------------------------------|
| 1 Air piping.  | 4 Galvanized thimble, by installer. |
| 2 Vent piping.   | 5 Bird screen, by installer.        |
| 3 Sidewall termination plates: for 4” PVC, use plates supplied with boiler in W-M vent/air plate kit; for 4” AL29-4C or 3” PVC, purchase optional sidewall separate pipes plate kit. | 6 Air inlet elbow.                  |
|  | 7 Elbow.                            |
|  | 8 Nipple.                           |
|  | 9 Elbow (vent termination).         |



# DIRECT VENT — Sidewall with W-M vent/air plate

## Allowable vent/air pipe materials & lengths

**▲WARNING** Use only the vent materials and kits listed in [Figure 24, page 21](#). Provide pipe adapters if specified.

1. Locate the termination such that the total air piping and vent piping from the boiler to the termination will not exceed the maximum length given in [Figure 23, page 20](#).

**Polypropylene** For polypropylene applications, comply with any additional requirements in the vent system manufacturer's instructions. Provide 4" PVC-to-PP transition pieces at the boiler vent and air connections. PP adapter must have smooth, straight section of pipe to insert in to the boiler vent and air connections and must fit and seal tightly. PP adapters with their own seal which would interfere with the internal seal of the boiler vent or air connections must not be used. Refer to [page 117](#) for a list of compliant adapters. Install a locking collar at every joint.

**AL29-4C S.S.** For AL29-4C vent pipe applications, comply with any additional requirements in the vent system manufacturer's instructions. Provide 4" PVC transition pieces at the boiler and at the vent and air terminations. (The air pipe must be PVC or CPVC.)

2. For 4" to 3" transitions, must use appropriate vent material. For polypropylene or stainless steel must use approved suppliers transitions (EVG 220 only).

## Determine termination location

1. Wall penetration thickness between 0" to 24".
2. The vent/air cap must be installed as shown in [Figure 33, page 28](#).
3. The termination must comply with clearances and limitations shown in [Figure 25, page 23](#).
4. Locate the termination so it is not likely to be damaged by foreign objects, such as stones or balls, or subject to buildup of leaves or sediment.

## Multiple vent/air terminations or termination adjacent to other appliance terminations

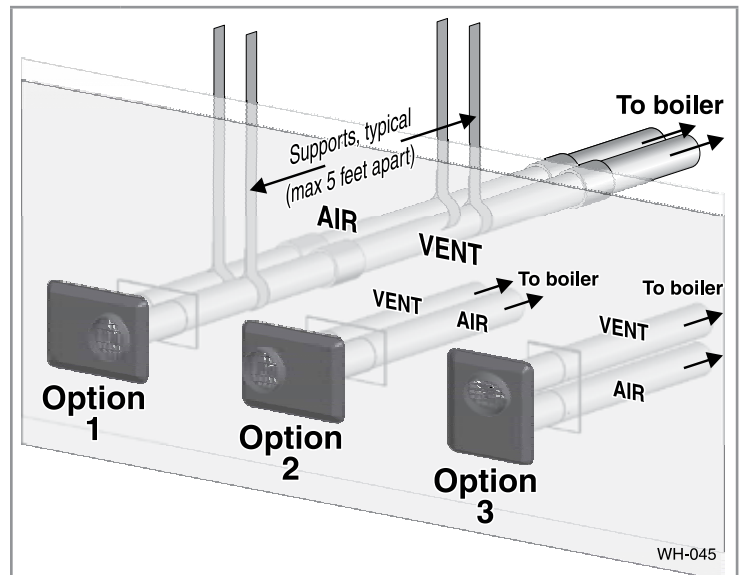
1. When terminating multiple Evergreen® boilers, terminate each vent/air connection as described in this manual.

**▲WARNING** All vent pipes and air inlets must terminate at the same height to avoid possibility of severe personal injury, death or substantial property damage.

2. Place wall penetrations to obtain minimum clearance as shown in for U. S. installations. For Canadian installations, provide clearances required by Natural Gas and Propane Installation Code, CAN/CSA B149.1 or B149.2 and a ULC S636 compliant vent kit.
3. The air inlet of a Evergreen® boiler is part of a direct vent connection. It is not classified as a forced air intake with regard to spacing from adjacent boiler vents.

**▲WARNING** For terminations of other appliances, provide at least the clearance shown. The installation must also comply with the manual for the other appliances.

Figure 30 INSTALLATION — W-M sidewall vent/air plate



Vent/air pipes and vent/air can be oriented as option 1, 2, or 3. DO NOT mount with plate vertical and vent outlet down.

- Step 1** Read and follow all instructions in this manual. **DO NOT proceed with vent/air installation until you have read [page 19 through page 24](#).** **Polypropylene** **AL29-4C S.S.** See notices at left.
- Step 2** Install the boiler in a location that allows proper routing of all vent and air piping to the selected sidewall location.
- Step 3** Make sure the selected sidewall termination location complies with [Figure 25, page 23](#). (Multiple boiler sidewall plates must also comply with [Figure 28, page 26](#).)
- Step 4** Use only the vent materials listed in [Figure 24, page 21](#). Provide pipe adapters where required.
- Step 5** Vent piping and air piping lengths must not exceed the values shown in [Figure 23, page 20](#).
- Step 6** Ensure proper clearance above grade or snowline. Keep vents/air intake area clear of accumulating snow.
- Step 7** Prepare the sidewall penetrations and secure the sidewall plates as instructed in this section. See "Install Weil-McLain vent/air cap" on [page 28](#).
- Step 8** The Weil-McLain plate termination must be installed before piping from the boiler to the termination.
- Step 9** Install vent and air piping between the boiler and the vent/air termination plate. Slope horizontal piping downward toward the boiler at least 1/4 inch per foot. See [page 38](#) for general guidelines.
- Step 10** Install pipe supports every 5 feet on both the horizontal and vertical runs, or per vent pipe manufacturer's instructions. **Polypropylene** **AL29-4C S.S.** See notices at left.
- Step 11** Install a hanger support within 6 inches of any upturn in the piping, or per vent pipe manufacturer's instructions. **Polypropylene** **AL29-4C S.S.** See notices at left.



**▲WARNING** USE SWEEP ELBOWS FOR ALL VENT AND AIR PIPING — DO NOT use short radius elbows for vent or air piping. Boiler performance could be affected.



# DIRECT VENT — Sidewall with W-M vent/air plate *(continued)*

## Install Weil-McLain vent/air cap

**⚠ WARNING** **ADAPTERS** — Use adapters if using other than 4-inch PVC or CPVC. This is required for different materials (polypropylene or AL29-4C stainless steel) or if using 3-inch pipe.

**NOTICE** The inside and outside cover plates are stamped to identify the exhaust (vent) and intake (air) openings. Make sure to orient the plates correctly.

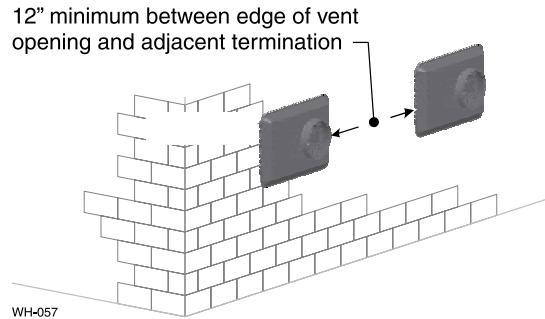
1. Locate termination opening and avoid obstructions:
  - a. Use the template supplied with the termination kit.
  - b. Locate the template on the outside building surface where the penetration is to be made.
  - c. Make sure there will be no obstructions that might prevent proper placement of the termination.
  - d. Use the template to mark the locations for the four mounting holes, flue pipe and air pipe. Level the template with a level.

**⚠ WARNING** For the Weil-McLain plate, the template must be level to ensure the flue and air pipe will be side-to-side, as shown in Figure 32. Failure to comply could result in severe personal injury, death or substantial property damage.

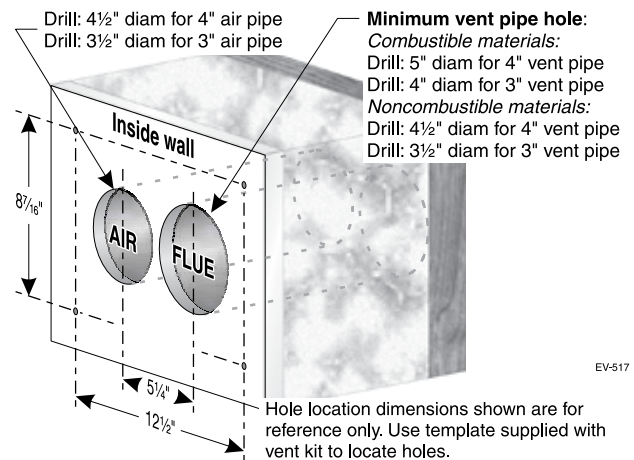
- e. Cut holes in the wall as shown in Figure 32, using the location marks made with the template. For best results, use a small-diameter, long drill bit to drill centering holes for the flue and air pipe openings. Then drill the large openings from both the inside and outside.
  - f. The flue pipe and air pipe may be run through a rectangular cutout (as marked on the template) in lieu of two separate holes if desired.
2. Drill holes for the screws or plastic anchors to secure the outside plate. Install the outside plate and mount the termination on the plate (temporarily).
    - a. Cut the flue pipe so the extension through the wall will cause the vent pipe to fully extend into the termination socket.
    - b. Cut the air pipe so the extension through the wall will butt the air pipe against the stops inside the termination.
    - c. Temporarily slide the flue and air pipes through the opening(s). Slide the inside wall plate over the two pipes and into position on the inside wall.
    - d. Position the inside plate so the flue pipe and air pipe slope downward slightly toward the boiler (1/4" per foot).
    - e. Mark the four (4) mounting holes for the plate.
    - f. Remove the vent and air pipe, drill the four mounting holes, and mount the inside plate.
  3. Test fit the vent/air termination on the vent pipe. Make sure the vent pipe fully penetrates the termination socket and the air pipe butts against the interior stops.
  4. Apply silicon RTV sealant to the interior of the vent termination and slide onto vent pipe. Rotate slightly to spread the silicon to ensure a tight seal around the vent pipe.
  5. Secure the termination in place using the four (4) #10 x 1/2" sheet metal screws and lock washers (see Figure 33).

**NOTICE** Vent/air pipes and W-M vent/air plate can be oriented in any of the configurations shown in [Figure 30, page 27](#).

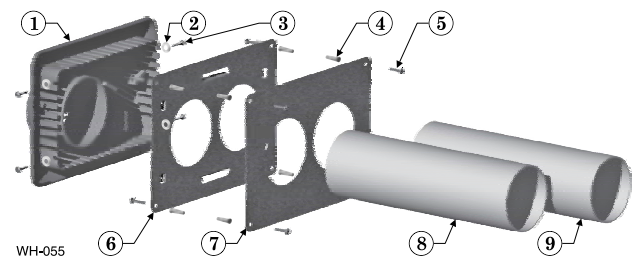
**Figure 31** Adjacent terminations — OUTSIDE VIEW — clearance from air inlet to exhaust from another appliance



**Figure 32** Hole preparation in wall — INSIDE VIEW (use template provided)



**Figure 33** Termination assembly — INSIDE VIEW Weil-McLain vent/air cap and plates



1 Vent termination (4")	6 Outer mounting plate
2 Lock washer, #10 (4)	7 Inner mounting plate
3 Sheet metal screw, #10 x 1/2" (4)	8 Vent pipe (butt to screen in termination)
4 Plastic wall anchor (8)	9 Air pipe (butt to stops in termination)
5 Sheet metal screw, #10 x 1 1/4" (8)	



# DIRECT VENT — Sidewall concentric

Instructions below - are for the WM 3” and 4” PVC Concentric Kit. If using Simpson-Duravent or Centrotherm Concentric kit, please refer to the manufacturer’s installation instructions.

## Allowable vent/air pipe materials & lengths

1. The concentric termination kit must be purchased separately.

**⚠WARNING** Use only the vent materials and kits listed in [Figure 24, page 21](#). Provide pipe adapters if specified.

2. Locate the termination such that the total air piping and vent piping from the boiler to the termination will not exceed the maximum length given in [Figure 23, page 20](#).
3. This termination requires a 45-degree elbow that is not supplied with the termination kit. The maximum vent/air pipe lengths include allowance for this elbow.

**Polypropylene** For polypropylene applications, comply with any additional requirements in the vent system manufacturer’s instructions. Provide 4” PVC-to-PP transition pieces at the boiler vent and air connections. PP adapter must have smooth, straight section of pipe to insert in to the boiler vent and air connections and must fit and seal tightly. PP adapters with their own seal which would interfere with the internal seal of the boiler vent or air connections must not be used. Refer to [page 117](#) for a list of compliant adapters. Install a locking collar at every joint.

**AL29-4C S.S.** For AL29-4C vent pipe applications, comply with any additional requirements in the vent system manufacturer’s instructions. Provide a 4” PVC transition at the boiler vent connection. Air pipe must be PVC or CPVC. Provide transition pieces to PVC at the vent and air pipe termination connections.

4. For 4” to 3” transitions, must use appropriate vent material. For polypropylene or stainless steel must use approved suppliers transitions (EVG 220 only).

## Determine termination location

1. Wall penetration thickness between 0” to 24”.
2. The concentric termination kit must be installed as shown in [Figure 36, page 30](#).
3. The termination must comply with clearances and limitations shown in [Figure 25, page 23](#).
4. Locate the termination so it is not likely to be damaged by foreign objects, such as stones or balls, or subject to buildup of leaves or sediment.

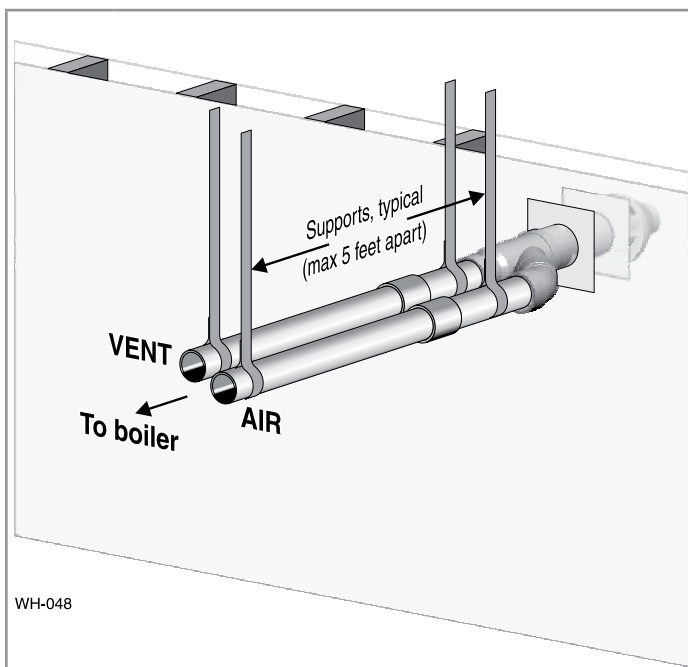
## Multiple vent/air terminations

1. When terminating multiple Evergreen® boilers, install each concentric termination as described in this manual.

**⚠WARNING** All vent pipes and air inlets must terminate at the same height to avoid possibility of severe personal injury, death or substantial property damage.

2. Place wall penetrations to obtain minimum clearance as shown in [Figure 36, page 30](#) for U. S. installations. For Canadian installations, provide clearances required by Natural Gas and Propane Installation Code, CAN/CSA B149.1 or B149.2 Installation Code and a ULC S636 compliant vent kit.
3. The air inlet of a Evergreen® boiler is part of a direct vent connection. It is not classified as a forced air intake with regard to spacing from adjacent boiler vents.

Figure 34 INSTALLATION SEQUENCE — Concentric horizontal



- Step 1** Read and follow all instructions in this manual. **DO NOT proceed with vent/air installation until you have read [page 19](#) through [page 24](#).** **Polypropylene AL29-4C S.S.** See notices at left.
- Step 2** Install the boiler in a location that allows proper routing of all vent and air piping to the selected sidewall location.
- Step 3** Make sure the selected sidewall termination location complies with [Figure 25, page 23](#). (Multiple boiler concentric terminations must also comply with [Figure 35, page 30](#).)
- Step 4** Use only the vent materials listed in [Figure 24, page 21](#). Provide pipe adapters where required.
- Step 5** Vent piping and air piping lengths must not exceed the values shown in [Figure 23, page 20](#).
- Step 6** Ensure proper clearance above grade or snowline. Keep vents/air intake area clear of accumulating snow.
- Step 7** The concentric termination must be assembled and installed before piping from the boiler to the termination.
- Step 8** Prepare the sidewall penetration — assemble the concentric termination kit and secure the cover plates as instructed in this section. Provide the supports indicated and mount the termination assembly. See “Install termination — concentric pipes” on [page 30](#). **Polypropylene AL29-4C S.S.** See notices at left.
- Step 9** Install vent and air piping between the boiler and the concentric vent/air termination. Slope horizontal piping downward toward the boiler at least 1/4 inch per foot. See [page 38](#) for general guidelines.
- Step 10** Install pipe supports every 5 feet on both the horizontal and vertical runs. **Polypropylene AL29-4C S.S.** See notices at left.
- Step 11** Install a hanger support within 6 inches of any upturn in the piping. **Polypropylene AL29-4C S.S.** See notices at left.



**⚠WARNING** USE SWEEP ELBOWS FOR ALL VENT AND AIR PIPING — DO NOT use short radius elbows for vent or air piping. Boiler performance could be affected.



# DIRECT VENT — Sidewall concentric *(continued)*

**Polypropylene** **AL29-4C S.S.** See notices on previous page.

## Install termination — concentric pipes

1. Assemble the vent termination as described for concentric terminations, on [page 35](#).

**⚠WARNING** If necessary, you can shorten the lengths of the inner and outer pipes for a shorter finished assembly. But you must ensure the pipes butt correctly at both ends. Failure to properly assemble the concentric termination can result in flue gas recirculation, causing possible severe personal injury or death.

2. Wall penetration:
  - a. Preferably, use a thimble with a 5½-inch hole (4" Concentric Kit) or a 4½-inch hole (3" Concentric Kit). If not using a thimble, carefully use a hole saw to cut a hole not larger than 5¾ or 4¾ inches in diameter through the wall. The finished hole must provide a solid stop for the rain cap ribs, as shown in the inset to [Figure 36](#).

**⚠WARNING** Ensure that the wall material is strong enough to prevent the rain cap from being pushed inward if struck or pushed from the outside.

3. Secure the termination in place so the rain cap will butt against the outside wall or outer thimble plate as shown in [Figure 36](#).
4. Before beginning vent and air piping from the boiler to the concentric termination, mount and secure the concentric termination as shown in [Figure 36](#).

**⚠WARNING** The vent and air piping must be securely supported, and must not rest its weight on the boiler fittings. Failure to properly support the vent and air piping could result in vent piping damage, resulting in possible severe personal injury, death or substantial property damage.

The supports/bracing used must support the termination assembly to prevent slippage or movement. See instructions provided with concentric kit for details.

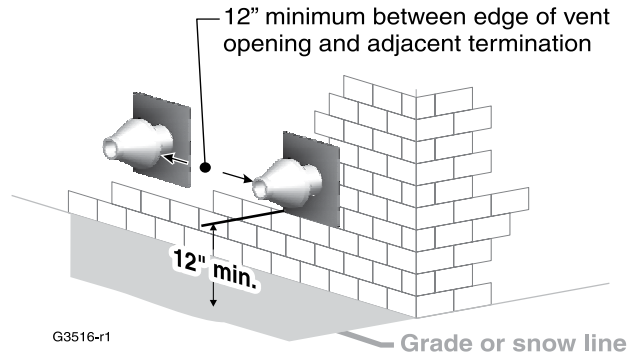
The clamps used on the outside of the termination pipe must not cut into the pipe or contain sharp edges that could cause a crack to form.

**⚠WARNING** When inserting the partially-assembled termination kit through the wall penetration, wrap plastic or other protection over the end of the exposed assembly to prevent debris from entering the pipes. If the air passages become blocked, the boiler will not operate. Once the rain cap has been cemented to the assembly, there is no way to correct the problem. The assembly would have to be replaced if it were cut to be removed and cleaned. Altering the assembly in any way could result in severe personal injury or death due to toxic flue product emissions.

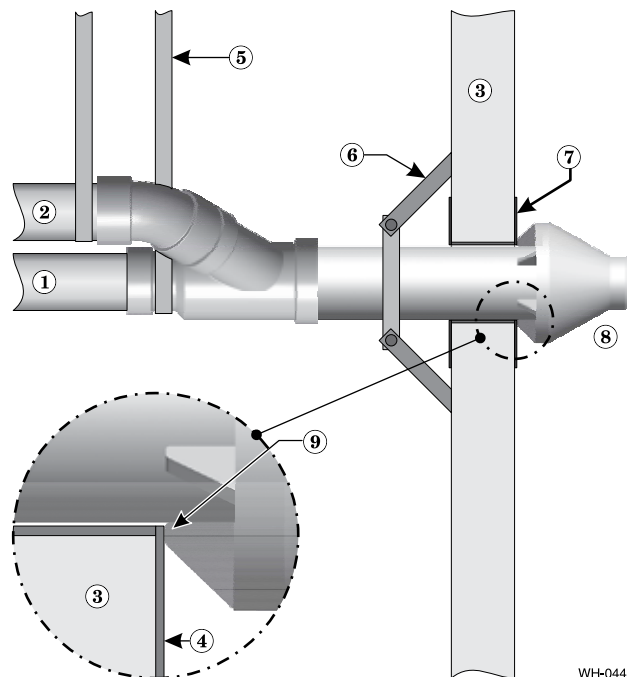
**⚠WARNING** If using AL29-4C stainless vent pipe, use the vent pipe manufacturer's PVC adapter if connecting to a PVC concentric vent attachment.

5. After the assembly has been positioned in the opening and all supports have been attached, install a bird screen (purchased separately if not included with the kit) and rain cap as follows:
  - a. Place the bird screen on the end of the inner pipe as in [Figure 42](#), [page 35](#), or per concentric kit instructions for polypropylene kits.
  - b. Cement the rain cap in place as shown.

**Figure 35** Termination location — concentric termination — multiple boilers — clearance from vent of one to air intake of the next



**Figure 36** Installing and supporting the concentric sidewall vent assembly



### LEGEND

- |  |  |
|--|--|
| 1 Vent pipe.   | 6 Wall brace, by installer, (or see vent pipe mfr's instructions).     |
| 2 Air pipe.  | 7 Thimble, by installer.   |
| 3 Wall.  | 8 Rain cap.  |
| 4 Outer thimble plate.                                       | 9 Rain cap ribs must butt against outer thimble plate or wall opening. |
| 5 Supports every 5 feet or per vent pipe mfr's instructions. |  |



# DIRECT VENT — Vertical with separate pipes

## Allowable vent/air pipe materials & lengths

**⚠ WARNING** Use only the vent materials and kits listed in Figure 24, page 21. Provide pipe adapters if specified.

1. Locate the terminations such that the total air piping and vent piping from the boiler to the termination will not exceed the maximum length given in Figure 23, page 20.

**Polypropylene** For polypropylene applications, comply with any additional requirements in the vent system manufacturer's instructions. Provide 4" PVC-to-PP transition pieces at the boiler vent and air connections. PP adapter must have smooth, straight section of pipe to insert in to the boiler vent and air connections and must fit and seal tightly. PP adapters with their own seal which would interfere with the internal seal of the boiler vent or air connections must not be used. Refer to page 117 for a list of compliant adapters. Install a locking collar at every joint.

**AL29-4C S.S.** For AL29-4C vent pipe applications, comply with any additional requirements in the vent system manufacturer's instructions. Provide a 4" PVC transition piece at the boiler vent connection. The air piping must be PVC or CPVC.

2. For 4" to 3" transitions, must use appropriate vent material. For polypropylene or stainless steel must use approved suppliers transitions (EVG 220 only).

## Determine termination location

1. Wall penetration thickness between 0" to 24".
2. The air and vent terminations must be installed as shown in Figure 37.
3. The terminations must comply with clearances and limitations shown in Figure 25, page 23.
4. Locate the terminations so they are not likely to be damaged by foreign objects, such as stones or balls, or subject to buildup of leaves or sediment.

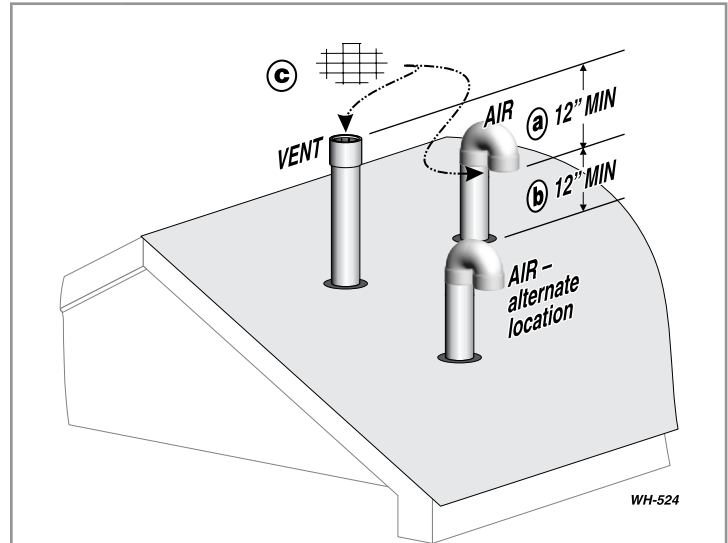
## Multiple vent/air terminations (Figure 38, page 32)

1. When terminating multiple Evergreen<sup>®</sup> boilers, terminate each vent/air connection as described in this section.

**⚠ WARNING** Terminate all vent pipes at the same height and all air pipes at the same height to avoid possibility of severe personal injury, death or substantial property damage.

2. Place roof penetrations to obtain minimum clearance of 12 inches between edge of air intake elbow and adjacent vent pipe of another boiler for U. S. installations (see Figure 38, page 32). For Canadian installations, provide clearances required by Natural Gas and Propane Installation Code, CAN/CSA B149.1 or B149.2 Installation Code and a ULC S636 compliant vent kit.
3. The air inlet of a Evergreen<sup>®</sup> boiler is part of a direct vent connection. It is not classified as a forced air intake with regard to spacing from adjacent boiler vents.

Figure 37 Separate pipes vertical termination



## Terminate vent and air pipes such that:

- a **AIR INTAKE IS AT LEAST 12 inches below vent outlet.**
- b **AIR INTAKE IS AT LEAST 12 inches above roof or snow line.** Keep vents/air intake area clear of accumulating snow.
- c **Vent and air terminations are fitted with bird screens.**

**Step 1** Read and follow all instructions in this manual. **DO NOT proceed with vent/air installation until you have read page 19 through page 24.** **Polypropylene** **AL29-4C S.S.** See notices at left.

**Step 2** Install the boiler in a location that allows proper routing of all vent and air piping to the selected location.

**Step 3** Make sure the selected vertical termination location complies with Figure 25, page 23. (Multiple boiler terminations must also comply with Figure 38, page 32.)

**Step 4** Use only the vent materials listed in Figure 24, page 21. Provide pipe adapters where required. Vent piping and air piping lengths must not exceed the values shown in Figure 23, page 20.

**Step 5** Prepare the vertical penetrations and secure penetration components as instructed in this section. See "Prepare roof penetrations" and "Termination and fittings" on page 32.

**Step 6** The air piping must terminate in a 180-degree return bend or **down-turned elbow** as shown above. The vent piping must terminate in a **coupling pointed upward** as shown above.

**Step 7** Install vent and air piping between the boiler and the vertical terminations. Slope horizontal piping downward toward the boiler at least 1/4 inch per foot. Install pipe supports every 5 feet on both the horizontal and vertical runs. Install a hanger support within 6 inches of any upturn in the piping. See page 38 for general guidelines. Also comply with vent pipe manufacturer's instructions. **Polypropylene** **AL29-4C S.S.** See notices at left.

**Step 8** Insert the vent and air piping through the vertical penetrations and secure the termination fittings.

**Step 9** Maintain clearances shown above. Vent and air terminations must be fitted with a bird screen as shown.



**⚠ WARNING**

**USE SWEEP ELBOWS FOR ALL VENT AND AIR PIPING — DO NOT use short radius elbows for vent or air piping. Boiler performance could be affected.**



# DIRECT VENT — Vertical with separate pipes *(continued)*

Polypropylene AL29-4C S.S. See notices on previous page.

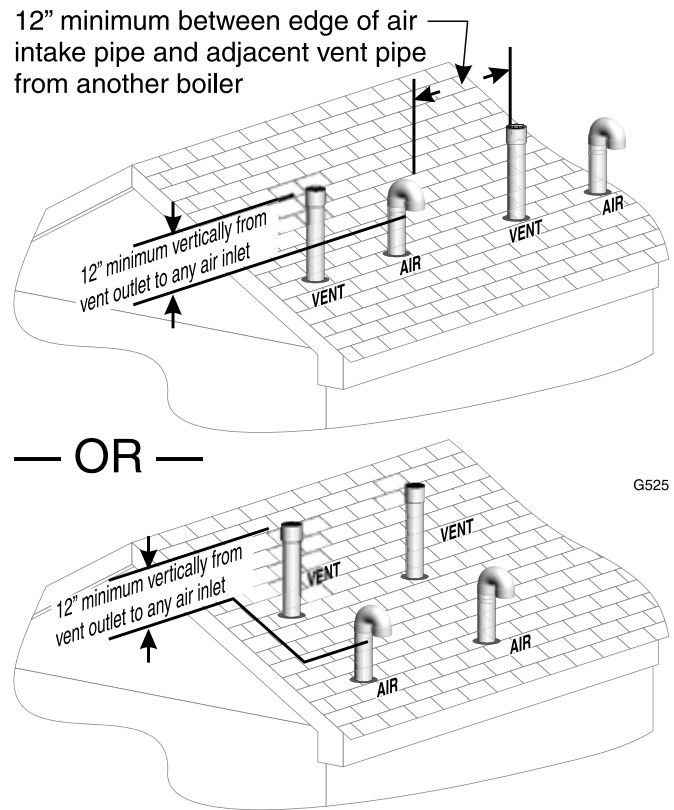
## Prepare roof penetrations

1. Air pipe penetration:
  - a. Cut a hole for the air pipe. Size the air pipe hole as close as desired to the air pipe outside diameter.
2. Vent pipe penetration:
  - a. Cut a hole for the vent pipe. For either combustible or noncombustible construction, size the vent pipe hole at least 0.4" larger than the vent pipe diameter.
  - b. Insert a galvanized metal thimble in the vent pipe hole.
3. Space the air and vent holes no closer than the minimum spacings shown in [Figure 38, page 32](#).
4. Follow all local codes and vent pipe manufacturer's instructions for isolation of vent pipe when passing through floors, ceilings and roofs.
5. Provide flashing and sealing boots sized for the vent pipe and air pipe. Follow all vent pipe manufacturer's instructions.

## Termination and fittings

1. Prepare the vent termination elbow and the air termination elbow ([Figure 37, page 31](#)) by inserting bird screens. Bird screens must be purchased separately. See the parts list at the end of this manual for part numbers.
2. The air piping must terminate in a down-turned 180-degree return bend as shown in [Figure 37, page 31](#). The edge of the air inlet elbow must be at least 12 inches above the roof or snow line.
3. The vent piping must terminate in an up-turned coupling as shown in [Figure 37, page 31](#). The top of the coupling must be at least 12 inches above the air intake in order to avoid the recirculation of flue products into the combustion air stream.
4. Maintain the required dimensions of the finished termination piping as shown in [Figure 37, page 31](#).
5. Do not extend exposed vent pipe outside of building more than shown in this document. Condensate could freeze and block vent pipe.

**Figure 38** Terminations for multiple boilers



G525



# DIRECT VENT — Vertical concentric

## Allowable vent/air pipe materials & lengths

1. The concentric termination kit must be purchased separately.

**WARNING** Use only the vent materials and kits listed in [Figure 24, page 21](#). Provide pipe adapters if specified.

2. Locate the termination such that the total air piping and vent piping from the boiler to the termination will not exceed the maximum length given in [Figure 23, page 20](#).
3. This termination requires a 45-degree elbow that is not supplied with the termination kit. The maximum vent/air pipe lengths include allowance for this elbow.

**Polypropylene** For polypropylene applications, comply with any additional requirements in the vent system manufacturer's instructions. Provide 4" PVC-to-PP transition pieces at the boiler vent and air connections. PP adapter must have smooth, straight section of pipe to insert in to the boiler vent and air connections and must fit and seal tightly. PP adapters with their own seal which would interfere with the internal seal of the boiler vent or air connections must not be used. Refer to [page 117](#) for a list of compliant adapters. Install a locking collar at every joint.

**AL29-4C S.S.** For AL29-4C vent pipe applications, comply with any additional requirements in the vent system manufacturer's instructions. Provide a 4" PVC transition at the boiler vent connection. Air pipe must be PVC or CPVC. Provide transition pieces to PVC at the vent and air pipe termination connections.

4. For 4" to 3" transitions, must use appropriate vent material. For polypropylene or stainless steel must use approved suppliers transitions (EVG 220 only).

## Determine termination location

Locate the concentric vent/air termination using the following guidelines:

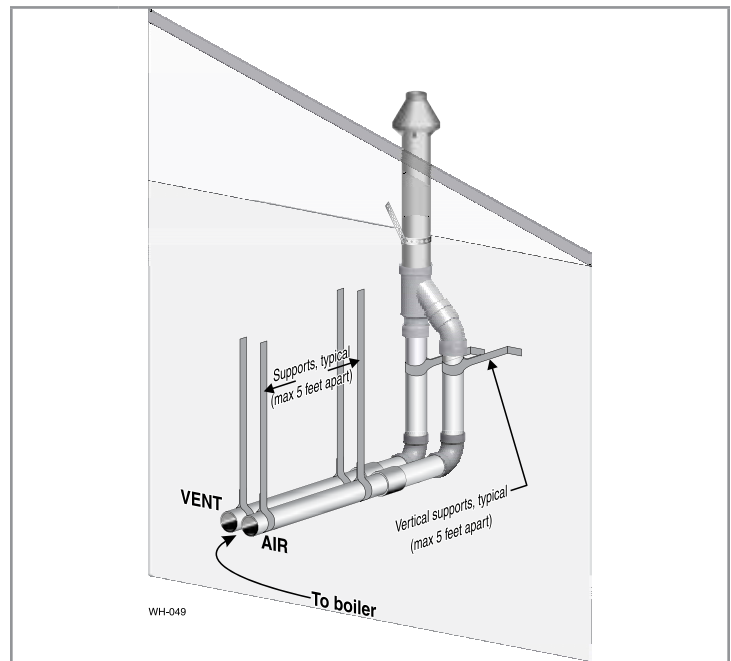
1. Wall penetration thickness between 0" to 24".
2. The concentric vent/air assembly must terminate as shown in these instructions.
3. The termination must comply with the clearances and limitations shown in [Figure 25, page 23](#).
4. Locate the termination so it is not likely to be damaged by foreign objects, such as stones or balls, or subject to buildup of leaves or sediment.
5. For Canadian installations, follow requirements of Natural Gas and Propane Installation Code, CAN/CSA B149.1 or B149.2 and a ULC S636 compliant vent kit.

## Multiple vent/air terminations

1. When terminating multiple Evergreen® boilers, install the concentric vent/air termination assemblies as described in this manual.

**WARNING** All vent outlets must terminate at the same height to avoid possibility of severe personal injury, death or substantial property damage.

Figure 39 INSTALLATION SEQUENCE — Concentric vertical



**Step 1** Read and follow all instructions in this manual. **DO NOT proceed with vent/air installation until you have read [page 19](#) through [page 24](#).** **Polypropylene** **AL29-4C S.S.** See notices at left.

**Step 2** Install the boiler in a location that allows proper routing of all vent and air piping to the selected location.

**Step 3** Make sure the selected vertical termination location complies with [Figure 25, page 23](#). (Multiple boiler vertical concentric terminations must also comply with [Figure 40, page 34](#).)

**Step 4** Use only the vent materials listed in [Figure 24, page 21](#). Provide pipe adapters where required.

**Step 5** Vent piping and air piping lengths must not exceed the values shown in [Figure 23, page 20](#).

**Step 6** The concentric termination must be assembled and installed before piping from the boiler to the termination.

**Step 7** Prepare the vertical penetration(s) — assemble the concentric termination kit and secure the penetration components as instructed in this section. Provide the supports indicated and mount the termination assembly. See "Prepare roof penetrations" and "Mount concentric termination" on [page 34](#). **Polypropylene** **AL29-4C S.S.** See notices at left.

**Step 8** Install vent and air piping between the boiler and the concentric vent/air termination. Slope horizontal piping downward toward the boiler at least 1/4 inch per foot. See [page 38](#) for general guidelines.

**Step 9** Install pipe supports every 5 feet on both the horizontal and vertical runs. **Polypropylene** **AL29-4C S.S.** See notices at left.

**Step 10** Install a hanger support within 6 inches of any upturn in the piping. **Polypropylene** **AL29-4C S.S.** See notices at left.



**WARNING** **USE SWEEP ELBOWS FOR ALL VENT AND AIR PIPING** — DO NOT use short radius elbows for vent or air piping. Boiler performance could be affected.



# DIRECT VENT — Vertical concentric *(continued)*

**Polypropylene** **AL29-4C S.S.** See notices on previous page.

2. Place roof penetrations to obtain minimum of 12 inches between centers of adjacent vent pipe of another boiler for U. S. installations (see Figure 40).
3. The air inlet of a Evergreen<sup>®</sup> boiler is part of a direct vent connection. It is not classified as a forced air intake with regard to spacing from adjacent boiler vents.

## Prepare roof penetrations

1. Roof penetration hole:
  - a. Cut a clearance hole to clear the termination outside diameter as prescribed in the kit instructions.
  - b. Insert a galvanized metal thimble in the vent pipe hole.
2. Follow all local codes for isolation of vent pipe when passing through floors, ceilings and roofs.
3. Provide flashing and sealing boots sized for the concentric termination outside diameter.

## Mount concentric termination

1. Assemble the vent termination as described for concentric termination, [page 35](#).
2. Mount the termination as shown in Figure 41.
3. Support the concentric vent/air termination at the roof penetration as shown in Figure 41 or per concentric kit instructions.
  - The supports/bracing used must support the termination assembly to prevent vertical slippage or sideways movement.
  - The clamps used on the outside of the termination pipe must not cut into the pipe or contain sharp edges that could cause a crack to form.

**⚠WARNING** The vent and air piping must be securely supported, and must not rest its weight on the boiler fittings. DO NOT drill or screw into either the vent pipe or air pipe. Failure to properly support the vent and air piping could result in vent piping damage, resulting in possible severe personal injury, death or substantial property damage.

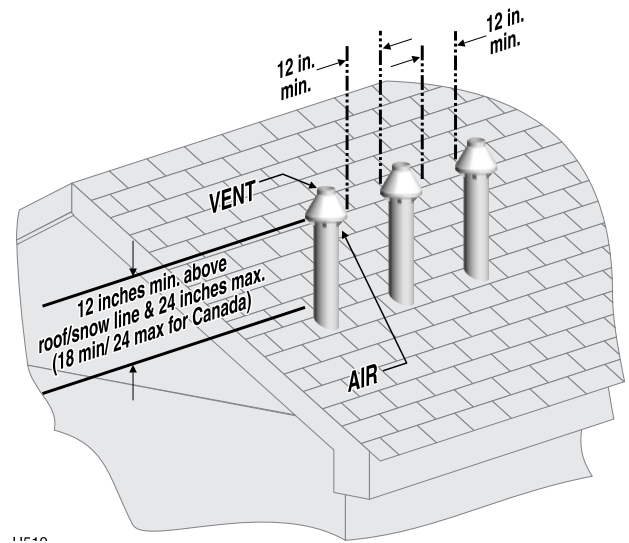
**⚠WARNING** When inserting the partially-assembled termination kit through the roof penetration, wrap plastic or other protection over the end of the exposed assembly to prevent debris from entering the pipes. If the air passages become blocked, the boiler will not operate. Once the rain cap has been cemented to the assembly, there is no way to correct the problem. The assembly would have to be replaced if it were cut to be removed and cleaned. Altering the assembly in any way could result in severe personal injury or death due to toxic flue product emissions.

**⚠WARNING** If using AL29-4C stainless vent pipe, use the vent pipe manufacturer's PVC adapter if connecting to a PVC concentric vent attachment.

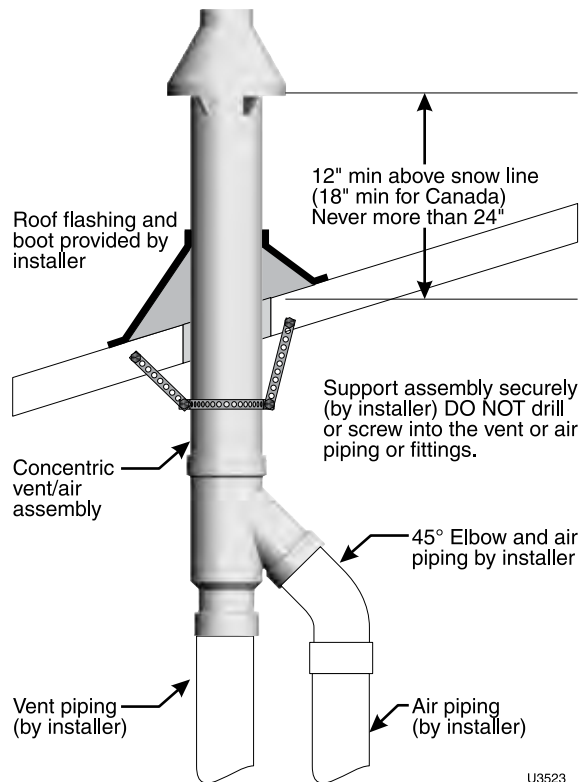
**⚠WARNING** Do not connect any other appliance to the vent pipe or multiple boilers to a common vent pipe.

4. After the assembly has been positioned in the roof opening and all supports have been attached, install a bird screen (purchased separately if not included with the kit) and rain cap as follows:
  - a. Place the bird screen on the end of the inner pipe as in [Figure 42, page 35](#), or per kit instructions for polypropylene kits.
  - b. Cement the rain cap in place.

**Figure 40** Vertical termination — concentric termination — single or multiple boilers



**Figure 41** PVC concentric termination supports



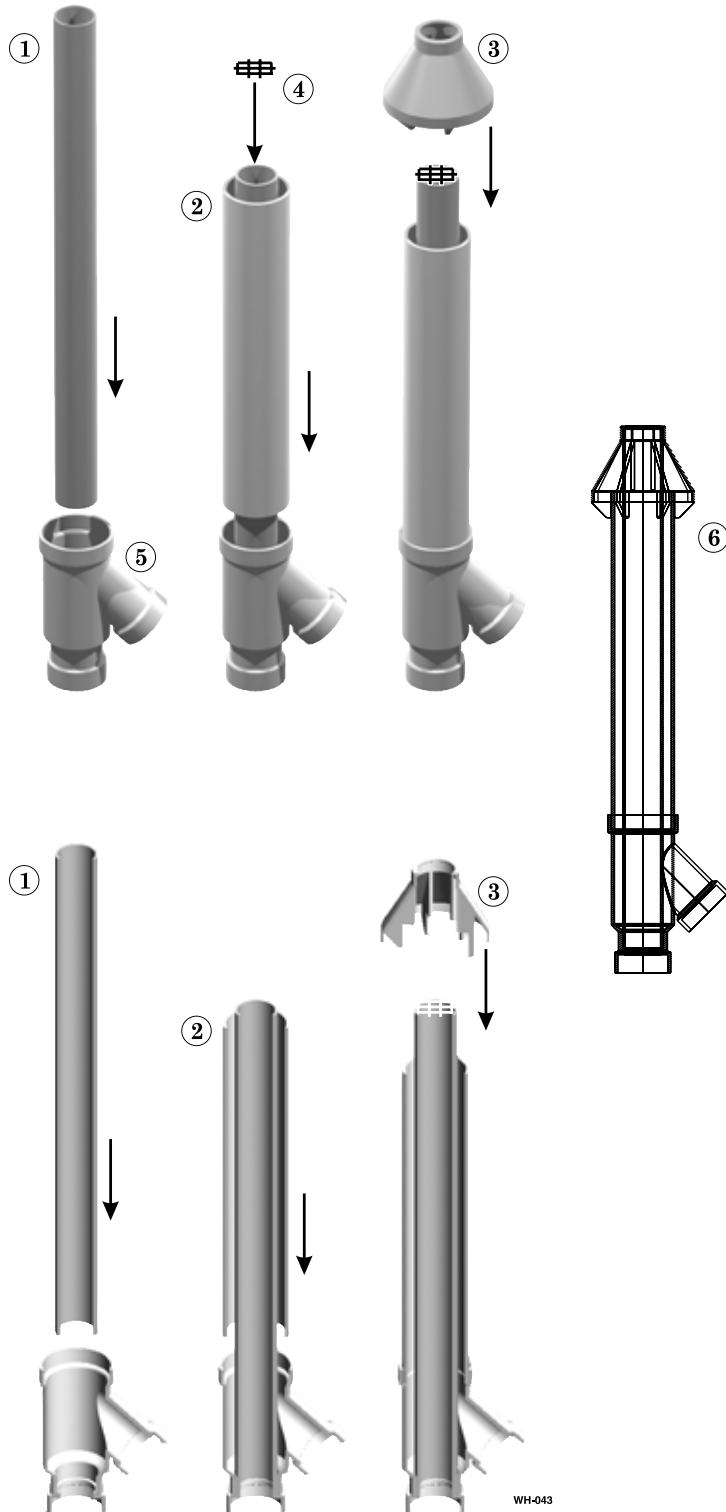
U3523



# Concentric termination, typical *(sidewall or vertical)*

**Figure 42** PVC concentric termination assembly — DO NOT attach the rain cap until the termination has been inserted through the roof or wall and all supports have been installed. See LEGEND at right. See kit instructions for details of polypropylene kits.

**LEGEND for Figure 42** — Inner PVC pipe (vent)  
 1 — Inner PVC pipe (vent)      4 — Bird screen  
 2 — Outer PVC pipe (air)      5 — Y fitting  
 3 — Rain cap                      6 — Finished assembly



## Assembling concentric termination

1. Follow all instructions provided with the concentric termination kit. The following are general guidelines for information only.
2. See Figure 42 for the typical assembly of a concentric termination assembly.
3. Prepare the bird screen, item 4 (purchase separately if not included with the kit). Cut the bird screen to size if required. If the bird screen must be trimmed, cut the bird screen to fit the outside diameter of the PVC inner pipe supplied with the termination kit.
4. Partially assemble the vent termination kit in the sequence shown in Figure 42, or per the concentric kit instructions.

**⚠ WARNING** DO NOT install the rain cap and bird screen until the assembly has been inserted through the roof (or sidewall) and all supports have been installed. Follow instructions to cover the end of the assembly with plastic before inserting through the roof penetration to prevent debris from blocking the air passages.

**⚠ WARNING** If necessary, you can shorten the lengths of the inner and outer pipes for a shorter finished assembly. But you must ensure the pipes butt correctly at both ends. Failure to properly assemble the concentric termination can result in flue gas recirculation, causing possible severe personal injury or death.

**Polypropylene** For polypropylene applications, comply with any additional requirements in the vent system manufacturer's instructions. Provide 4" PVC-to-PP transition pieces at the boiler vent and air connections. PP adapter must have smooth, straight section of pipe to insert in to the boiler vent and air connections and must fit and seal tightly. PP adapters with their own seal which would interfere with the internal seal of the boiler vent or air connections must not be used. Refer to [page 117](#) for a list of compliant adapters. Install a locking collar at every joint.

**AL29-4C S.S.** For AL29-4C vent pipe applications, comply with any additional requirements in the vent system manufacturer's instructions. Provide a 4" PVC transition at the boiler vent connection. Air pipe must be PVC or CPVC. Provide transition pieces to PVC at the vent and air pipe termination connections.

5. For 4" to 3" transitions, must use appropriate vent material. For polypropylene or stainless steel must use approved suppliers transitions (EVG 220 only).



# DIRECT VENT — Vertical vent / sidewall air

## Allowable vent/air pipe materials & lengths

**⚠ WARNING** Use only the vent materials and kits listed in [Figure 24, page 21](#). Provide pipe adapters if specified.

1. Locate the terminations such that the total air piping and vent piping from the boiler to the termination will not exceed the maximum length given in [Figure 23, page 20](#).

**Polypropylene** For polypropylene applications, comply with any additional requirements in the vent system manufacturer's instructions. Provide 4" PVC-to-PP transition pieces at the boiler vent and air connections. PP adapter must have smooth, straight section of pipe to insert in to the boiler vent and air connections and must fit and seal tightly. PP adapters with their own seal which would interfere with the internal seal of the boiler vent or air connections must not be used. Refer to [page 117](#) for a list of compliant adapters. Install a locking collar at every joint.

**AL29-4C S.S.** For AL29-4C vent pipe applications, comply with any additional requirements in the vent system manufacturer's instructions. Provide a 4" PVC transition piece at the boiler vent connection. The air piping must be PVC or CPVC.

2. For 4" to 3" transitions, must use appropriate vent material. For polypropylene or stainless steel must use approved suppliers transitions (EVG 220 only).

## Prepare roof penetration

1. Vent pipe penetration:
  - a. Cut a hole for the vent pipe. For either combustible or noncombustible construction, size the vent pipe hole at least 0.4" larger than the vent pipe diameter.
  - b. Insert a galvanized metal thimble in the vent pipe hole.
2. Follow all local codes for isolation of vent pipe when passing through floors, ceilings and roofs.
3. Provide flashing and sealing boots sized for the vent pipe and air pipe.

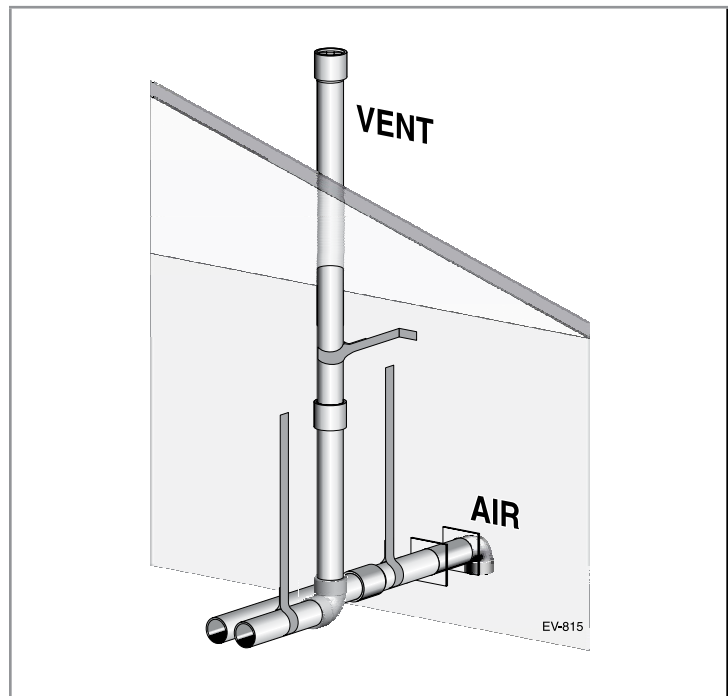
## Vent termination and fittings

1. Prepare the vent termination coupling by inserting a bird screen. Bird screens must be purchased separately. See the parts list at the end of this manual for part numbers.
2. Maintain the required dimensions of the finished termination piping as shown in [Figure 44, page 37](#).

## Multiple vent terminations

1. When terminating multiple Evergreen boilers, terminate each vent/air connection as described in this section.
2. Place adjacent terminations at least 6 inches apart.
3. For Canadian installations, provide clearances required by Natural Gas and Propane Installation CAN/CSA B149.1 or B149.2 Installation Code.

**Figure 43** INSTALLATION SEQUENCE — Vertical vent/ sidewall air



- Step 1** Read and follow all instructions in this manual. **DO NOT proceed with vent/air installation until you have read [page 19](#) through [page 24](#).** **Polypropylene** **AL29-4C S.S.** See notices at left.
- Step 2** Install the boiler in a location that allows proper routing of all vent and air piping to the selected locations.
- Step 3** Make sure the selected vertical termination location complies with [Figure 25, page 23](#).
- Step 4** Use only the vent materials listed in [Figure 24, page 21](#). Provide pipe adapters where required. Vent piping and air piping lengths must not exceed the values shown in [Figure 23, page 20](#).
- Step 5** Prepare the vertical penetration (vent) and sidewall penetration (air) and secure penetration components as instructed in this section.
- Step 6** The air piping must terminate in a 90-degree **down-turned elbow** as shown above. The vent piping must terminate in a **coupling pointed upward** as shown above.
- Step 7** Install vent and air piping between the boiler and the air and vent terminations. Slope horizontal piping downward toward the boiler at least 1/4 inch per foot. Install pipe supports every 5 feet on both the horizontal and vertical runs. Install a hanger support within 6 inches of any upturn in the piping. See [page 38](#) for general guidelines. Also comply with vent pipe manufacturer's instructions. **Polypropylene** **AL29-4C S.S.** See notices at left.
- Step 8** Insert the vent and air piping through the penetrations and secure the termination fittings.
- Step 9** Maintain clearances shown in this section. Vent and air terminations must be fitted with bird screens as shown.



**⚠ WARNING**

**USE SWEEP ELBOWS FOR ALL VENT AND AIR PIPING** — DO NOT use short radius elbows for vent or air piping. Boiler performance could be affected.



# DIRECT VENT — Vertical vent / sidewall air *(continued)*

## Determine location for air inlet elbow

1. The air inlet of an Evergreen boiler is part of a direct vent connection. It is not classified as a forced air intake with regard to spacing from adjacent appliance terminations.
2. Locate the air inlet elbow (termination) using the following guidelines.
3. The air piping must terminate in a down-turned elbow as shown in Figure 45.
  - a. Apply the configuration on the left side of Figure 45 unless the terminations would fail to meet minimum clearance to grade or snow line.
  - b. Apply the configuration on the right side of Figure 45 when the terminations need to be raised higher to meet clearance to grade or snow line.
  - c. The air pipe may run up the side of the building, as shown. The vent and air pipes must be secured with braces, and all clearances and lengths must be maintained. Space braces no further than 24 inches apart.
4. You must consider the surroundings when terminating the air connection:
  - a. Make sure there are no obstructions for air flow. DO NOT locate the termination where plants could grow and cause obstruction to air flow.
  - b. Do not locate the terminations where wind eddies could affect performance or cause recirculation with exhaust from other appliances, such as inside building corners, near adjacent buildings or surfaces, window wells, stairwells, alcoves, courtyards or other recessed areas.
  - c. Locate the air inlet termination at least 12 inches below and 12 inches horizontally from any appliance or building vent outlet.
5. Locate terminations so they are not likely to be damaged by foreign objects, such as stones or balls, or subject to buildup of leaves or sediment.

## Multiple air terminations

1. When terminating multiple Evergreen boiler air connections, terminate each air connection as described in this manual.
2. Place wall penetrations to obtain minimum clearances as instructed in this manual.
3. Place adjacent air inlets for multiple Evergreen boilers at least 6 inches apart.
4. For Canadian installations, provide clearances required by Natural Gas and Propane Installation CAN/CSA B149.1 or B149.2 Installation Code.
5. Combustion air (NOT vent piping) can be manifolded as shown in the Evergreen Advanced manual.

## Prepare wall penetrations

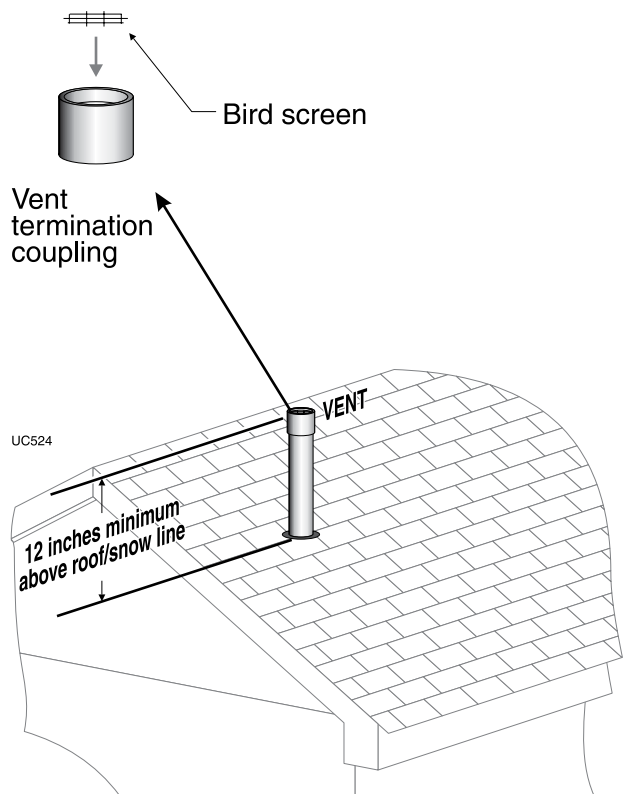
1. Air pipe penetration:
  - a. Cut a hole for the air pipe. Size the air pipe hole as close as desired to the air pipe outside diameter.
2. Seal exterior openings thoroughly with exterior caulk.

## Termination and fittings

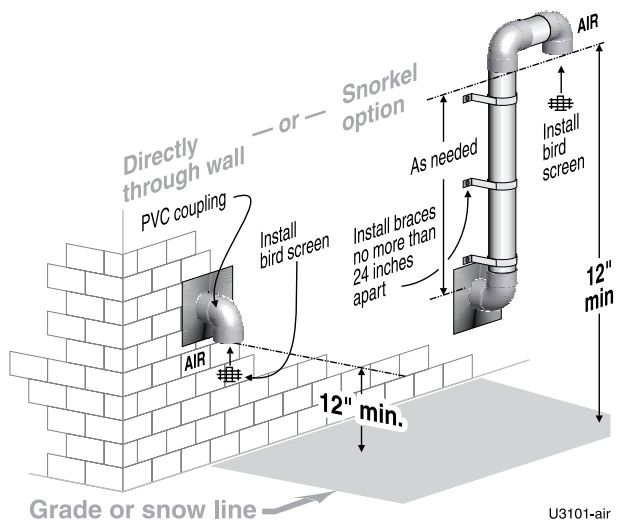
1. Prepare the air termination elbow (Figure 45) by inserting a bird screen. Bird screens must be purchased separately. See the parts list at the end of this manual for part numbers.
2. Use metal plates (by installer) at inside and outside penetrations using the method shown in Figure 29, page 26.

**NOTICE** If extending the air pipe out from the wall, install a coupling on each pipe. Mount the piping with the coupling flush with the outer plate.

**Figure 44** Vent termination (through the roof) for direct vent: vertical vent / sidewall air



**Figure 45** Sidewall air inlet (termination) for direct vent: vertical vent / sidewall air





# Vent and air piping and boiler connections

## Follow termination instructions

Read and follow all instructions for the termination type used before proceeding with this page. Follow all instructions provided by vent pipe manufacturer.

**▲WARNING** Use only materials from the manufacturers listed in Figure 24, page 21.

## Installing vent and air piping

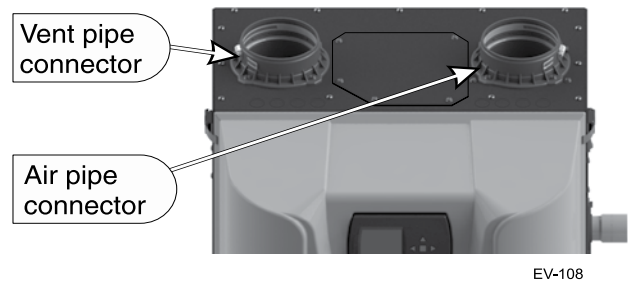
**Polypropylene** For polypropylene applications, comply with any additional requirements in the vent system manufacturer's instructions. Provide 4" PVC-to-PP transition pieces at the boiler vent and air connections. PP adapter must have smooth, straight section of pipe to insert in to the boiler vent and air connections and must fit and seal tightly. PP adapters with their own seal which would interfere with the internal seal of the boiler vent or air connections must not be used. Refer to [page 117](#) for a list of compliant adapters. Install a locking collar at every joint.

**NOTICE** For locations with regulatory or code requirements to use only listed plastic or polymeric venting systems, the use of ULC S636 listed venting systems are allowed. See [Figure 23, page 20](#) and [Figure 24, page 21](#).

**AL29-4C S.S.** For AL29-4C vent pipe applications, comply with any additional requirements in the vent system manufacturer's instructions. Provide a 4" PVC transition piece at the boiler vent connection. Air piping must be PVC or CPVC. Connect to the boiler air piping only with 4" PVC (use a transition piece for 3" air pipe). Provide 4" PVC connections at the termination if using the W-M termination plate. Provide 3" or 4" PVC transitions at the termination if using a PVC concentric vent kit.

1. Work from the boiler to vent or air termination. Do not exceed the lengths given in the previous pages for either the air or vent piping.
2. See Figure 46 for attaching vent (and air) pipes at the boiler. Connections must be 4" PVC or CPVC only — use transitions if needed to adapt to other material or size (3"). When transitioning to 3", use tapered reducer.
3. Cut pipe to required lengths.
4. Dry assemble entire vent or air piping to ensure proper fit before assembling any joint.
5. Maintain minimum clearance of 3/16 inch between vent pipe and any combustible wall or material.
6. Seal wall or floor penetration openings following local code requirements.
7. Assembling PVC or CPVC: **(Polypropylene AL29-4C S.S.)** — follow pipe manufacturer's instructions for preparation and assembly)
  - a. Deburr inside and outside of pipe ends.
  - b. Chamfer outside of each pipe end to ensure even cement distribution when joining.
  - c. Clean all pipe ends and fittings. Dry thoroughly.
  - d. For each joint:
    - Handle fittings and pipes carefully to prevent contamination of surfaces.
    - Apply primer liberally to both joint surfaces — pipe end and fitting socket.
    - While primer is still damp, lightly apply approved cement to both surfaces in a uniform coating.
    - Apply a second coat to both surfaces. Avoid using too much cement on sockets to prevent cement buildup inside.
    - With cement still wet, insert pipe into fitting, twisting ¼ turn. Make sure pipe is fully inserted.
    - Wipe excess cement from joint. Check joint to be sure a smooth bead of cement shows around the entire joint.

**Figure 46** Boiler vent and air connections



EV-108

**▲WARNING ADAPTERS** — Use adapters if using other than 4-inch PVC or CPVC. This is required for different materials or if using 3-inch pipe.

1. Use ONLY 4" PVC or CPVC pipe at boiler connections.
2. Clean and deburr inside and outside of both ends of air and vent pipes. Chamfer boiler end of vent pipe for ease of insertion.

**▲WARNING** The vent pipe end must be smooth and chamfered to prevent possible damage to sealing gasket in vent pipe adapter.

3. Inspect vent or air adapter (above) — verify no obstructions or foreign objects inside.
4. Loosen clamp screw.
5. Measure 3 inches from end of pipe and make a mark with felt-tip pen.
6. Loosen adapter clamp screw.
7. Apply small amount of silicon grease to end of pipe to ease insertion.
8. Insert pipe into adapter.
9. Slide pipe down until the 3 inch mark is reached.

**▲WARNING** Do not apply excessive force or bend the adapter or flue/air pipe when inserting. The adapter or seal could be damaged. If any portion of the vent or air system is damaged, it must be replaced.

10. Secure vent or air pipe by tightening the adapter clamp securely. Do not overtighten.
11. The seal is accomplished with the internal gasket. The clamp is only to hold the pipe in place.

**▲WARNING** When transitioning to 4-inch to 3-inch, use tapered reducer with 4" nipple (6" Length or greater). Do NOT use 4-inch to 3-inch bushing. Bushing will NOT seal in boiler adapter.

**▲WARNING USE SWEEP ELBOWS FOR ALL VENT AND AIR PIPING** — DO NOT use short radius elbows for vent or air piping. Boiler performance could be affected.



# Install water piping

**⚠ WARNING** Use two wrenches when tightening water piping at boiler, using one of the wrenches to prevent the boiler interior piping from turning. Failure to support the boiler piping connections to prevent them from turning could cause damage to boiler components.

## General piping information

### Additional controls, if required

**NOTICE** The control uses temperature sensors to provide both high limit protection and modulating temperature control. The control module also provides low water protection by sensing the temperature of the heat exchanger. **The control's high limit function requires manual reset.** Some codes/jurisdictions may require additional external controls for high limit and/or low water cutoff protection.

### Additional limit controls

Following standard industry practices, if installation is to comply with ASME or Canadian requirements, an additional high temperature limit may be needed. Consult local requirements for other codes/standards to determine if needed.

1. Install a manual reset high temperature limit constructed to prevent a temperature setting above 200°F in system supply piping between boiler and isolation valve. (Note that the Control operating limit function shuts the boiler down at 195°F, or lower if set to a lower value.)

**⚠ WARNING Multi-temperature systems** — If the heating system includes circuits that require lower temperature water (radiant slab circuits, for example) as well as higher temperature circuits, it is recommended to protect low-temperature circuits with limit controls that are wired to a Control external limit circuit terminals.

2. See instructions beginning on [page 52](#) for wiring information.
3. When using a manual reset limit control or wiring in the manual reset circuit, preferably set Max. Boiler Temperature or Supply Max. at least 20°F less than the external manual reset limit (i.e., set control no higher than 180°F for a 200°F external limit, for example).

### Separate low water cutoff

1. A separate low water cutoff device is recommended when the boiler is installed above piping level, and may be required by certain state or local codes or insurance companies. Consult local requirements to determine. See the NOTICE above regarding the inherent protection provided by the Control module. Low water cutoff is standard equipment with the Evergreen<sup>®</sup> boilers.
2. The Control's integral protection is accepted in many jurisdictions as meeting the requirement for low water protection. See [page 56](#) for details.
3. When required, use a low water cutoff designed for water installations. Electrode probe-type is recommended.

See [Replacement parts](#) for the Weil-McLain low water cut-off kit.

4. Purchase low water cutoff and install in a tee in the supply piping above boiler.
5. See field wiring instructions beginning on [page 52](#) for wiring additional limit controls.

### Backflow preventer

Use backflow preventer in the cold water supply piping if required by local codes.

### Boiler loop pipe sizing

#### (Baseboard, convectors or cast iron radiators ONLY)

For residential space heating applications (other than radiant heating or unit heaters) ONLY, you can use the sizing suggestions in [Figure 47](#).

**Figure 47** Suggested pipe sizing for boiler loop

Model	Boiler loop
EVG 220	1¼" or larger
EVG 299, 300 or 399	1½" or larger

Recommendations are based on a 25°F (EVG 220/299/300) and 30°F (EVG 399) temp rise through the boiler.

**Figure 48** Pressure drop through the Evergreen<sup>®</sup> heat exchanger

EVG 220			EVG 299/300			EVG 399		
Flow Rate (GPM)	Head Loss (ft. w.c.)	ΔT (°F)	Flow Rate (GPM)	Head Loss (ft. w.c.)	ΔT (°F)	Flow Rate (GPM)	Head Loss (ft. w.c.)	ΔT (°F)
10**	0.0	45	13**	0.0	45	18**	0.0	45
12	0.0	37	18	0.3	33	24	0.3	33
14	0.1	31	22*	0.6	27	28*	0.7	29
16	0.2	28	28	1.2	21	32	1.1	25
18*	0.2	24	32	1.7	19	36	1.6	22
20	0.3	22	–	–	–	40	2.2	20
22	0.5	20	–	–	–	–	–	–

\* Suggested design flow rates based on a 25°F (EVG 220/299/300) and 30°F (EVG 399) temp rise through the boiler.  
 \*\* Minimum flow rates.

**⚠ CAUTION** Use **at least** the **MINIMUM** pipe size shown in [Figure 47](#) on all boiler loop piping (connecting boiler to and from the primary/secondary connection). **Use only primary/secondary piping as shown.** Failure to follow these guidelines could result in system problems.



# Install water piping *(continued)*

## System water piping methods

**NOTICE** All piping methods shown in this manual use primary/secondary connection to the boiler loop. These designs ensure proper flow through the boiler, for the most efficient and reliable operation of the boiler and the heating system. For other piping methods, consult your local Weil-McLain representative or see separate boiler piping guides.

## Circulators

The boiler circulator (Taco 0014 for Evergreen® 220, 299 and 300; Taco 0013 for Evergreen® 399) is shipped loose. Locate it in the boiler outlet, as shown in the appropriate piping diagram in this manual.

**WARNING** DO NOT use the boiler circulator in any location other than the ones shown in this manual. The boiler circulator is selected to ensure adequate flow through the boiler.

Failure to comply could result in unreliable performance and nuisance shut downs from insufficient flow.

## System circulators and zone circulators

Install a system circulator or zone circulators as shown in the piping diagrams in this manual. These circulators must be supplied by the installer.

### System or zone circulator flow rate

1. Size circulators based on the flow rate required to achieve the temperature change needed.
2. You can closely estimate temperature rise (or drop) through a circuit by using the following formula, where TD is temperature rise (or drop), FLOW is flow rate (in gpm), and BTUH is the heat load for the circuit:

$$\text{FLOW} = \frac{\text{BTUH}}{\text{TD} \times 500}$$

**Example:**

Consider a system loop for a system with total heating load equal to 210,000 Btuh. The desired temperature drop through the system piping is 20°F. Then the required flow rate is:

$$\text{FLOW} = \frac{210,000}{20 \times 500} = 21 \text{ gpm}$$

**SIMPLIFIED:**

For 20° temperature drop, FLOW = MBH / 10.

### System or zone circulator head requirement

1. The circulator must be capable of delivering the required flow against the head loss that will occur in the piping.
2. Determine the pipe size needed and the resultant head loss using accepted engineering methods.
3. The simplified pipe sizing here is limited to residential systems, and does not include systems with fan coil units or radiant tubing.

**CAUTION** The following simplified method for pipe and circulator sizing must be limited to residential applications using baseboard (finned or cast iron), cast iron radiators or convectors. DO NOT apply for radiant heating, fan coil units or commercial installations.

## Simplified pipe/circulator selection

1. Install the boiler and piping using the recommended piping layouts shown in this manual.
2. Size the piping and components for each circuit in the space heating system using [Figure 49, page 41](#). **At the flow rates listed, the head loss in all piping will be 0.04 feet per foot of pipe.**
  - a. Determine the heating load (Btuh) for each circuit.
  - b. Calculate the flow rate for each circuit using its load.
  - c. To use a 20°F temperature drop, just divide the MBH (1,000's of Btuh) by 10.
  - d. Example — Flow for 20°F temp drop with 35,000 Btuh:  
FLOW = 35 MBH / 10 = 3.5 gpm
  - e. Find the pipe size in [Figure 49, page 41](#) that has a max flow rate just larger than that required for the circuit.
  - f. Find the total equivalent length (TEL) of the circuit.
  - g. TEL accounts for losses through fittings and valves by using the equivalent length of pipe that would cause the same head loss. Add these numbers to the measured length of the circuit to find TEL in feet.
  - h. **TEL is usually close to 1.5 times the length of the circuit for residential baseboard, radiator or convector applications.**
  - i. Measure the length of each circuit from the circulator outlet back to its inlet. Then multiply this length times 1.5 to get the approximate TEL of the circuit.
  - j. Find the head loss for each circuit:  
TEL = 1.5 X Circuit Length (feet)  
HEAD = TEL X 0.04 (feet water column)
  - k. NOTE: Size system header piping for the total flow of all connected zones.
3. Example:
  - a. For a circuit with heating load = 45,000 Btuh (= 45 MBH). Measured length of circuit is 88 feet.
  - b. Flow = 45 MBH / 10 = 4.5 gpm.
  - c. TEL = 1.5 x 88 feet = 132 feet.
  - d. From [Figure 49, page 41](#), select 1" pipe (max flow = 7.1 gpm).
  - e. Head loss = TEL x 0.04 = 132 x 0.04 = 5.28 feet.
  - f. Select a circulator that can deliver at least 4.5 gpm at a head of 5.28 feet. (Read the NOTICE below.)

**NOTICE** To use this method, limit the flow through ¾" finned-tube baseboard to 3.9 gpm, or use 1" baseboard and limit flow to 7.1 gpm. If the total load of the circuit requires more flow, split the circuit into two or more.



# Install water piping *(continued)*

**Figure 49** Flow rates for *0.04 feet head loss per foot* of pipe (140°F water)

Pipe size (inches)	MAX Flow rate (GPM) @ 0.04 feet per foot	Pipe size (inches)	MAX Flow rate (GPM) @ 0.04 feet per foot
¾	3.9	2	45
1	7.1	2½	75
1¼	16	3	140
1½	24	4	290

## Install relief valve

1. Install relief valve in a reducing tee, NPT, 1½” x 1¼” x ¾” on Evergreen® 220 or 1½”x 1½”x ¾” on Evergreen® 299/300/399 on the boiler supply piping tee (Figure 6, page 11). The Evergreen® 220, 299 and 300 boilers come shipped loose with a 30 PSIG, 375 MBTU relief valve. The Evergreen® 399 boiler comes shipped loose with a 30 PSIG, 575 MBTU relief valve. This boiler is capable of a pressure up to 80 PSIG. Please see Miscellaneous parts and kits in [Replacement parts](#) for Weil-McLain alternate pressure components.
2. If using a relief valve with a rating higher than 30 psi, other system components may require higher pressure rated equipment such as pressure gauges and expansion tank. Consult local requirements and other codes/standards for required equipment, if needed.
3. Pipe the relief valve only as shown, in the location shown.
4. Connect discharge piping to safe disposal location, following guidelines in the following **WARNING**.

## Install pipe unions (recommended)

Install pipe unions 1½” NPT on boiler supply and boiler return, [Figure 6, page 11](#). Installing unions in these locations will aid in future service. Pipe unions are NOT included with the boiler.

## Connecting to Heating Coils:

If the boiler piping system is connected to heating coils located in air handling units where there may be exposed to refrigerated air circulation then it must be equipped with flow control valves or other automatic means to prevent gravity circulation of the boiler water during the cooling cycle.

**WARNING** To avoid water damage or scalding due to relief valve operation, as per local or state codes:

Install relief valve ONLY with the spindle vertical, as shown in illustrations in this manual.

Discharge line must be connected to relief valve outlet and run to a safe place of disposal. Terminate the discharge line in a manner that will prevent possibility of severe burns or property damage should the valve discharge. Locate away from the top of the boiler.

Discharge line must be as short as possible and be the same size as the valve discharge connection throughout its entire length.

Discharge line must pitch downward from the valve and terminate at least 6” above the floor drain where any discharge will be clearly visible.

The discharge line shall terminate plain, not threaded, with a material serviceable for temperatures of 375 °F or greater.

Do not pipe the discharge to any place where freezing could occur.

No shutoff valve shall be installed between the relief valve and boiler, or in the discharge line. Do not plug or place any obstruction in the discharge line.

Test the operation of the valve after filling and pressurizing system by lifting the lever. Make sure the valve discharges freely. If the valve fails to operate correctly, replace it with a new relief valve.

Failure to comply with the above guidelines could result in failure of the relief valve to operate, resulting in possibility of severe personal injury, death or substantial property damage.



# Expansion tank

## Expansion tank

Figure 50 and Figure 51 show typical installations of the system expansion tank. Always locate the air separator and expansion tank as shown in the suggested piping drawings, beginning on [page 43](#).

Ensure that the expansion tank size will handle boiler and system water volume and temperature. Allow 4.6 gallons for Evergreen<sup>®</sup> 220, 7.0 gallons for Evergreen<sup>®</sup> 299/300 and 6.7 gallons for Evergreen<sup>®</sup> 399. See tank manufacturer's instructions and ratings for details. Additional tanks may be added to the system if needed to handle the expansion. These tanks may be installed by connecting to tees in the system piping.

**CAUTION** **Undersized expansion tanks** cause system water to be lost from the relief valve and makeup water to be added through the fill valve. Eventual boiler failure can result due to excessive make-up water addition. Always locate the **cold water fill connection** at the expansion tank. Never locate this elsewhere in the system.

### Diaphragm- or bladder-type tank:

Refer to Figure 50 for suggested piping when using a diaphragm- or bladder-type expansion tank.

**NOTICE** **Diaphragm- or bladder-type expansion tank** — Control **fill pressure** with the tank air charge pressure. Always check pressure and charge tank **with tank removed from system** to be sure reading is accurate. Boiler relief valve is set for 30 PSIG. Operating pressure of system, after temperature expansion above cold fill pressure, should not exceed 24 PSIG to avoid weeping of relief valve.

Install an **automatic air vent** on top of the air separator, per separator manufacturer's instructions.

### Closed-type expansion tank:

**CAUTION** DO NOT use a closed-type tank if connecting to a water heater that is equipped with an automatic air vent.

Figure 51 shows suggested piping when using a closed-type expansion tank, in which the air is directly in contact with tank water.

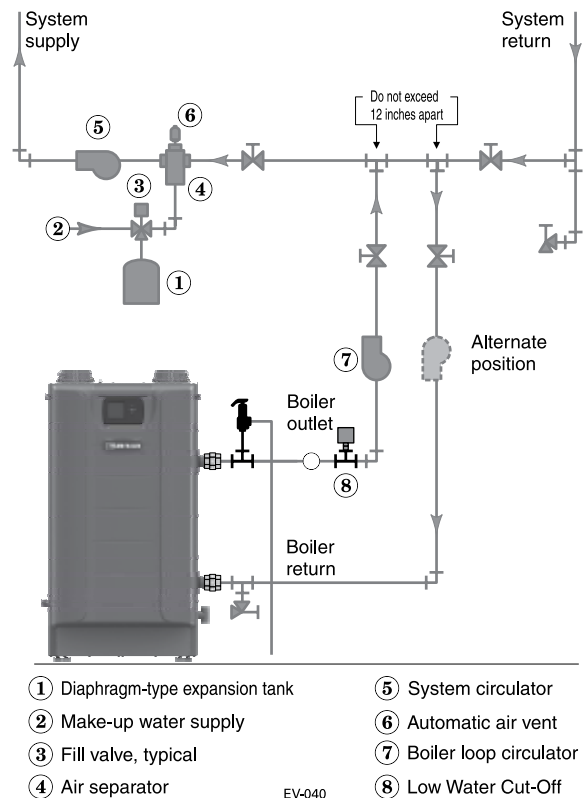
Connect piping ( $\frac{1}{2}$ " or  $\frac{3}{4}$ " ) from the air separator top outlet to the tank fitting. Slope any horizontal piping a minimum of 1 inch per 5 feet of horizontal pipe.

Always use a **tank fitting**, such as the B&G *Tanktrol* or Taco *Taco-Trol* (shown). The fitting reduces gravity flow of water in the piping to the tank, avoids air bubbling through the tank water, and provides the proper fill height in the tank.

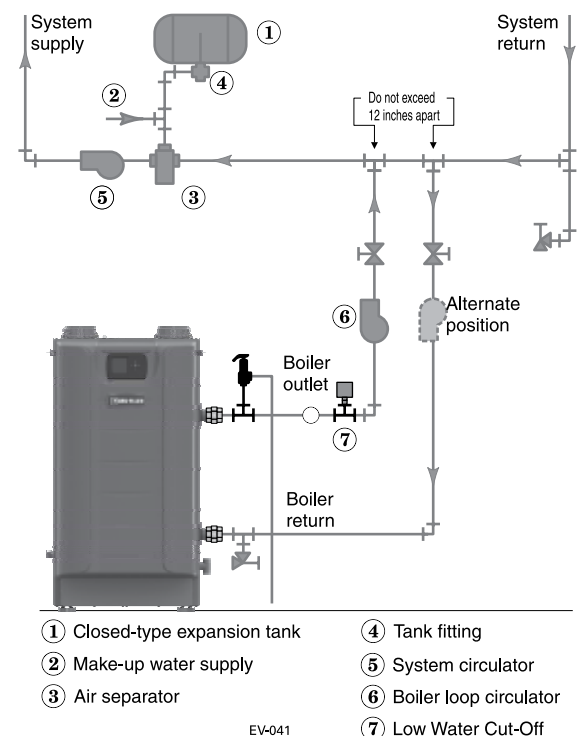
**CAUTION** **Correct all leaks** in the system or tank piping. Leaks allow air to escape from the system and will cause water-logging of the tank. This will result in water loss through the boiler relief valve due to over-pressurization. **NEVER** use an automatic air vent in a system equipped with a closed-type expansion tank. The air removed from the system will cause water-logging of the expansion tank.

**NOTICE** **Closed-type expansion tank** — Follow tank manufacturer's instructions for **filling the tank**. Typical tank sizing provides for approximately 12 PSIG when the tank is filled to the normal level and system water is cold. Note that boiler relief valve is set for 30 PSIG. Operating pressure of system, after temperature expansion above cold fill pressure, should not exceed 24 PSIG to avoid weeping of relief valve.

**Figure 50** Piping to diaphragm (or bladder) type expansion tank



**Figure 51** Piping to closed -type expansion tank





# System piping - Single Boiler Systems

## See Advanced Manual for Multiple Boiler Systems

### ZONE VALVE zoning – primary/secondary (Shown with optional DHW piping) See Figure 52.

This configuration is for zone valve systems using a boiler loop connected as a secondary circuit off of a primary system loop.

1. Install a system circulator (supplied by installer) capable of delivering the proper flow and head as shown.
2. The flow/check valve shown on the boiler outlet piping prevents gravity circulation in the boiler loop during DHW heating.

**CAUTION** Use at least the **MINIMUM** pipe size shown in Figure 47, page 39 on all boiler loop piping (connecting boiler to and from the primary/secondary connection, item 14). Use only primary/secondary piping as shown. Failure to follow these guidelines could result in system problems.

#### Expansion Tank required

1. Provide a system expansion tank following the guidelines on page 42.
2. **DO NOT** use a closed-type tank if connecting to a water heater that is equipped with an automatic vent.

#### Domestic Hot Water (DHW) tank, if used

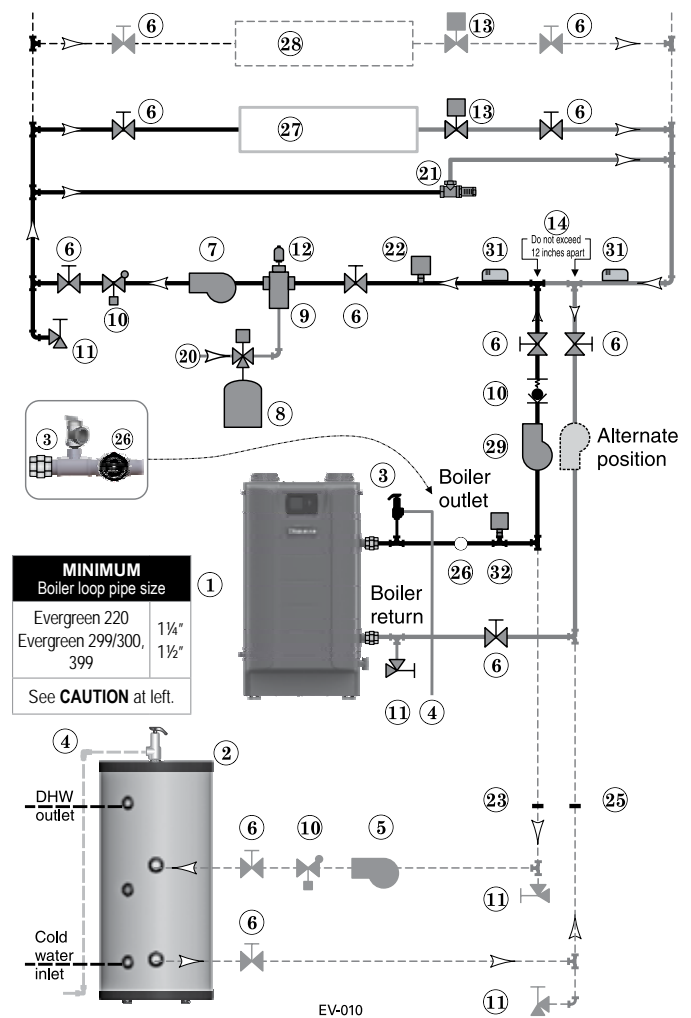
1. DHW direct connection—Pipe from the near-boiler piping to the DHW tank's boiler connections as shown.
2. DHW as zone— A DHW tank can be connected as a zone if a DHW tank is **NOT** already connected to the boiler. See notices on page 129 to ensure compliance with the 2007 Energy Act. See Advanced Manual to configure Boiler Pump to run during DHW demands and change TARGET MOD SENSOR to System Supply.
3. DHW Priority operation— Using Priority 1 for DHW (default) will turn off lower priorities during DHW calls. The MAX ON TIME setting can be adjusted to limit how long this occurs. Use Priority 2 or 3 for DHW if DHW priority is not desired.

**NOTICE** Overriding the Outdoor Reset function by setting control to DHW mode when system is intended for space heating may violate **Section 303 of the 2007 Energy Act**. See page 129 for compliance information and exemptions.

#### Controlling the circulators

1. The control can control up to four circulators (boiler circulator and three others). Refer to Field wiring, beginning on page 52, for instructions on wiring to circulators.
2. The factory default settings are: all three inputs are set up for Space Heating (Priority 2). Each input correlates to its respective circulator output. For DHW Priority applications, wire aquastat to Input 1 and assign to Priority 1. See Field wiring instructions, beginning on page 52, for details.

**Figure 52** Zone valve zoning —primary/secondary connection — a system circulator is required



3. For more than 3-zones, use Weil-McLain WMZV zone valve controller.

**NOTICE** Connect zone valve end switches to Priority 2 input. Connect system circulator to Circ. 2 output.

**CAUTION** Use isolation relays if connecting 3-wire zone valve end switches to the HEAT input.

#### LEGEND for Figure 52

**Note:** This is a common legend for all piping diagrams. Not all items listed appear in every figure.

1 Evergreen boiler	14 Primary/secondary connection (tees no more than 12 inches apart)	23 DHW tank boiler water supply connection, when used
2 Indirect Water Heater, if used	15 Expansion tank, closed type, if used (some chiller systems may use a diaphragm-type expansion tank)	24 Zone circulator
3 Relief valve, supplied with boiler, field piped — MUST be piped to boiler supply connection — see page 41 for information	16 Water chiller	25 DHW tank boiler water return connection, when used
4 Relief valve piping to drain — see page 41.	17 Check valve	26 Pressure/temperature gauge, supplied with boiler, field piped
5 DHW circulator	18 Y-strainer	27 Heating circuits
6 Isolation valves	19 Balancing valve	28 Additional heating circuits,
7 System circulator	20 Make-up water supply – Use applicable codes to determine if backflow preventers, pressure reducing valves, and fill valves may be required	29 Boiler circulator
8 Expansion tank, diaphragm type, if used	21 By-pass pressure regulator; Recommended for zone valve systems unless other provision is made	30 Mixing device, if any
9 Air separator	22 High limit temperature control, when required by local code or for a radiant system.	31 System supply and return sensors: Strap system sensors to lines as shown, at least 6 pipe diameters (but no more than 3 feet) from boiler connection tees.
10 Flow/check valves or spring check		32 Low Water Cut-off
11 Purge/drain valves (one drain valve shipped loose with boiler)		
12 Auto air vent		
13 Zone valves		



# System piping - Single Boiler Systems *(continued)*

## See Advanced Manual for Multiple Boiler Systems

### Circulator zoning – primary/secondary (Shown with optional DHW piping)

See Figure 53.

1. This configuration is for circulator-zoned systems using a boiler loop connected as a secondary circuit off of a primary system loop. Systems zoned with circulators must pipe the boiler loop as a secondary circuit as shown.
2. Install a separate circulator (supplied by installer) for each zone capable of delivering the proper flow and head as shown.
3. The flow/check valve shown on the boiler outlet piping prevents gravity circulation in the boiler loop during DHW heating.

**CAUTION** Use **at least the MINIMUM** pipe size shown in Figure 47, page 39 on all boiler loop piping (connecting boiler to and from the primary/secondary connection, item 14). **Use only primary/secondary piping as shown.** Failure to follow these guidelines could result in system problems.

#### Expansion Tank required

1. Provide a system expansion tank following the guidelines on page 42.
2. **DO NOT** use a closed-type tank if connecting to a water heater that is equipped with an automatic vent.

#### Domestic Hot Water (DHW) tank, if used

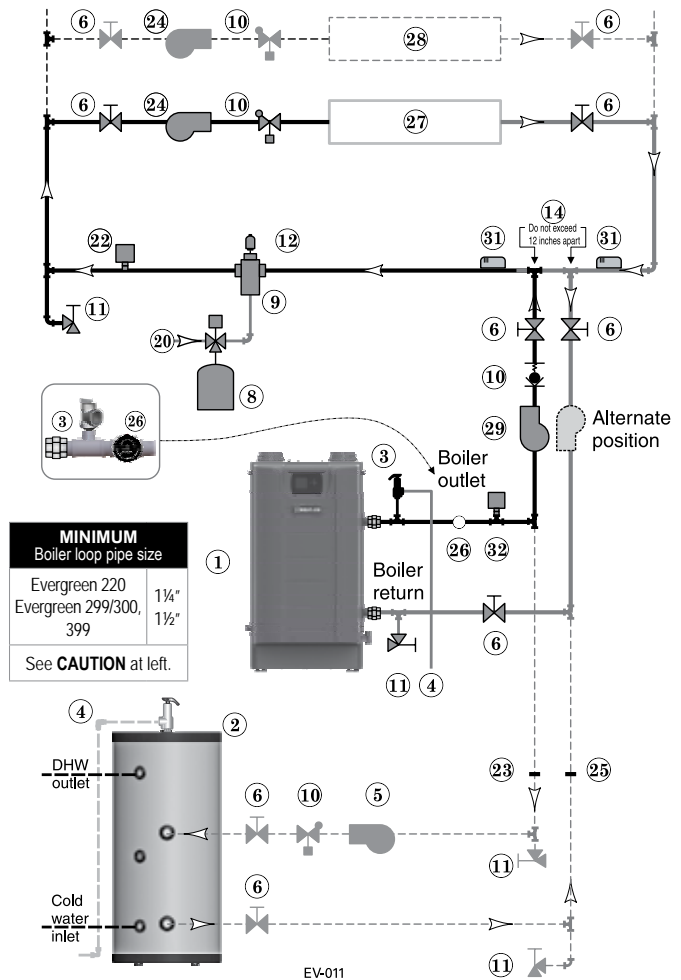
1. DHW direct connection—Pipe from the near-boiler piping to the DHW tank's boiler connections as shown.
2. DHW as zone— A DHW tank can be connected as a zone if a DHW tank is **NOT** already connected to the boiler. See notices on page 129 to ensure compliance with the 2007 Energy Act. See Advanced Manual to configure Boiler Pump to run during DHW demands and change TARGET MOD SENSOR to System Supply.
3. DHW Priority operation— Using Priority 1 for DHW (default) will turn off lower priorities during DHW calls. The MAX ON TIME setting can be adjusted to limit how long this occurs. Use Priority 2 or 3 for DHW if DHW priority is not desired.

**NOTICE** Overriding the Outdoor Reset function by setting control to DHW mode when system is intended for space heating may violate **Section 303 of the 2007 Energy Act.** See page 129 for compliance information and exemptions.

#### Controlling the circulators

1. The control can control up to four circulators (boiler circulator and three others). Refer to Field wiring, beginning on page 52, for instructions on wiring to circulators.

Figure 53 Circulator zoning plus optional DHW piping



2. The factory default settings are: all three inputs are set up for Space Heating (Priority 2). Each input correlates to its respective circulator output. For DHW Priority applications, wire aquastat to Input 1 and assign to Priority 1. See Field wiring instructions, beginning on page 52, for details.
3. For more than 3-zones, use Weil-McLain WMCR zone Circ controller.

#### LEGEND for Figure 53 and Figure 54, page 45

**Note:** This is a common legend for all piping diagrams. Not all items listed appear in every figure.

1 Evergreen boiler	14 Primary/secondary connection (tees no more than 12 inches apart)	23 DHW tank boiler water supply connection, when used
2 Indirect Water Heater, if used	15 Expansion tank, closed type, if used (some chiller systems may use a diaphragm-type expansion tank)	24 Zone circulator
3 Relief valve, supplied with boiler, field piped — MUST be piped to boiler supply connection — see page 41 for information	16 Water chiller	25 DHW tank boiler water return connection, when used
4 Relief valve piping to drain — see page 41.	17 Check valve	26 Pressure/temperature gauge, supplied with boiler, field piped
5 DHW circulator	18 Y-strainer	27 Heating circuits
6 Isolation valves	19 Balancing valve	28 Additional heating circuits, if any
7 System circulator	20 Make-up water supply — Use applicable codes to determine if backflow preventers, pressure reducing valves, and fill valves may be required	29 Boiler circulator
8 Expansion tank, diaphragm type, if used	21 By-pass pressure regulator, Recommended for zone valve systems unless other provision is made	30 Mixing device, if any
9 Air separator	22 High limit temperature control, when required by local code or for a radiant system.	31 System supply and return sensors: Strap system sensors to lines as shown, at least 6 pipe diameters (but no more than 3 feet) from boiler connection tees.
10 Flow/check valves or spring check		32 Low Water Cut-off
11 Purge/drain valves (one drain valve shipped loose with boiler)		
12 Auto air vent		
13 Zone valves		



# System piping - Single Boiler Systems *(continued)*

## See Advanced Manual for Multiple Boiler Systems

### Circulator zoning – Multiple temperature zones with primary/secondary (Shown with optional DHW piping)

See Figure 54.

1. This configuration is for circulator-zoned systems with **high- and low-temperature heating zones** using a boiler loop connected as a secondary circuit off of a primary system loop. Systems zoned with circulators must pipe the boiler loop as a secondary circuit as shown.
2. Install a separate circulator (supplied by installer) for each zone capable of delivering the proper flow and head as shown.
3. The flow/check valve shown on the boiler outlet piping prevents gravity circulation in the boiler loop during DHW heating.

**CAUTION** Use at least the **MINIMUM** pipe size shown in Figure 47, page 39 on all boiler loop piping (connecting boiler to and from the primary/secondary connection, item 14). **Use only primary/secondary piping as shown.** Failure to follow these guidelines could result in system problems.

#### Expansion Tank required

1. Provide a system expansion tank following the guidelines on page 42.
2. **DO NOT** use a closed-type tank if connecting to a water heater that is equipped with an automatic vent.

#### System setup and settings

1. Hi-temp emitters may be baseboards, radiators, fan coils, or heat exchangers.
2. Add a mixing device (Figure 54, item 30) to help ensure supply water temperature will not exceed the maximum allowable for the radiant system.
3. Heating zone supply water temperature settings should be selected for the hi-temp zones. The mixing device regulates supply temperature to the lower-temp zones.

#### Domestic Hot Water (DHW) tank, if used

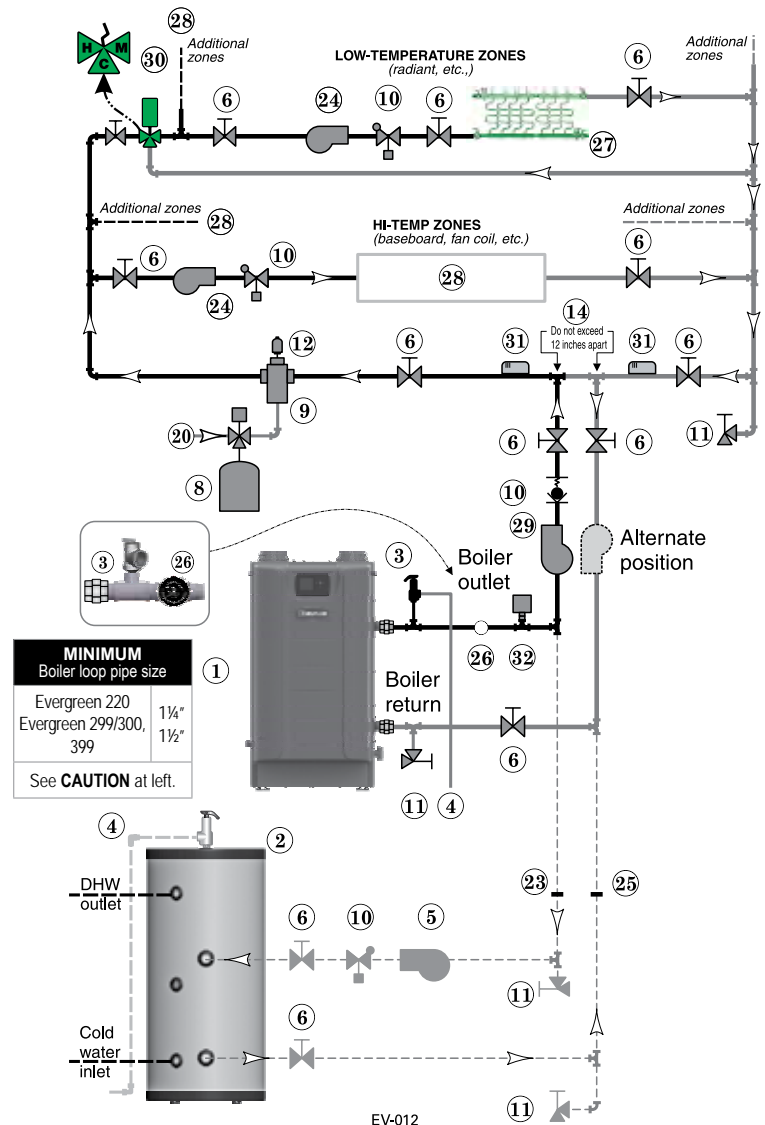
1. DHW direct connection—Pipe from the near-boiler piping to the DHW tank's boiler connections as shown.
2. DHW as zone— A DHW tank can be connected as a zone if a DHW tank is **NOT** already connected to the boiler. See notices on page 129 to ensure compliance with the 2007 Energy Act. See Advanced Manual to configure Boiler Pump to run during DHW demands and change TARGET MOD SENSOR to System Supply.
3. DHW Priority operation— Using Priority 1 for DHW (default) will turn off lower priorities during DHW calls. The MAX ON TIME setting can be adjusted to limit how long this occurs. Use Priority 2 or 3 for DHW if DHW priority is not desired.

**NOTICE** Overriding the Outdoor Reset function by setting control to DHW mode when system is intended for space heating may violate Section 303 of the 2007 Energy Act. See page 129 for compliance information and exemptions.

#### Controlling the circulators

1. The Control can control up to four circulators (boiler circulator and three others). Refer to Field wiring, beginning on page 52, for instructions on wiring to circulators.

Figure 54 Circulator zoning with high- and low-temperature heating zones



2. The factory default settings are: all three inputs are set up for Space Heating (Priority 2). Each input correlates to its respective circulator output. For DHW Priority applications, wire aquastat to Input 1 and assign to Priority 1. See Field wiring instructions, beginning on page 52, for details.
3. For more than 3-zones, use Weil-McLain WMCR zone Circ controller.
4. The Control can operate the Hi-Temp Zones and Low-Temp Zones at the same time when the corresponding inputs are set to the same priority (default: Priority 2). A mixing device must be used in this application to guarantee the proper temperature to the Low-Temp Zones. Two different Priorities can also be used in this application (such as Priority 2 and Priority 3). One priority used for the Hi-Temp Zones and the other used for the Low-Temp Zones. This will allow the boiler to run at lower temperatures while satisfying the Low-Temp Zones thus increasing the boilers efficiency. Proper safety measures should be taken to ensure safe water temperatures to the Low-Temp Zones such as a Mixing device and/or a High Limit Temperature Control. The Control can only satisfy one priority at a time. Please set min and max on timers for each priority for optimal performance.



# System piping - Single Boiler Systems *(continued)*

## See Advanced Manual for Multiple Boiler Systems

### Radiant Heating — Circulator zoning — primary/secondary (Shown with optional DHW piping)

See Figure 55.

1. The Evergreen® boiler is ideal for use in radiant heating. The unique heat exchanger design allows it to work well even in condensing mode. There is no need to regulate boiler return water temperature in radiant heating applications.
2. Apply this configuration for typical radiant heating applications.
3. Size the system piping and circulators to provide the flow and pressure drop needed.
4. The flow/check valve shown on the boiler outlet piping prevents gravity circulation in the boiler loop during DHW heating.

**CAUTION** Use **at least** the **MINIMUM** pipe size shown in [Figure 47, page 39](#) on all boiler loop piping (connecting boiler to and from the primary/secondary connection). **Use only primary/secondary piping as shown.** Failure to follow these guidelines could result in system problems.

#### High limit in system piping

1. Add the recommended high limit control (Figure 55, item 22) to help ensure supply water temperature will not exceed the maximum allowable for the radiant system.
2. Wire the limit control to either the manual reset or automatic reset external limit circuit of the Control.

#### Expansion Tank required

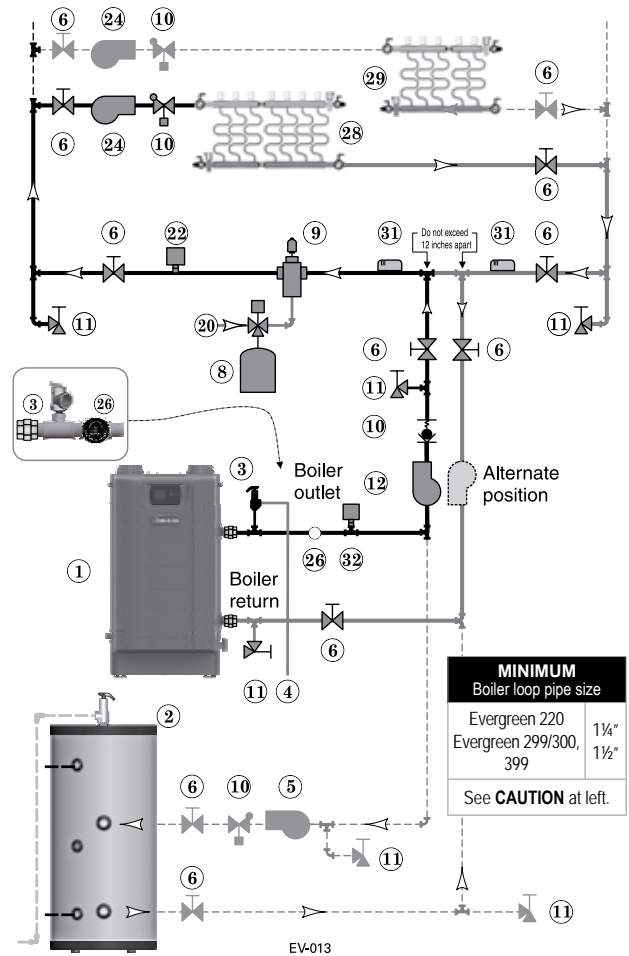
1. Provide a system expansion tank following the guidelines on [page 42](#).
2. **DO NOT** use a closed-type tank if connecting to a water heater that is equipped with an automatic vent.

#### Domestic Hot Water (DHW) tank, if used

1. DHW direct connection—Pipe from the near-boiler piping to the DHW tank's boiler connections as shown.
2. DHW as zone— A DHW tank can be connected as a zone if a DHW tank is **NOT** already connected to the boiler. See notices on [page 129](#) to ensure compliance with the 2007 Energy Act. See Advanced Manual to configure Boiler Pump to run during DHW demands and change TARGET MOD SENSOR to System Supply.
3. DHW Priority operation— Using Priority 1 for DHW (default) will turn off lower priorities during DHW calls. The MAX ON TIME setting can be adjusted to limit how long this occurs. Use Priority 2 or 3 for DHW if DHW priority is not desired.

**NOTICE** Overriding the Outdoor Reset function by setting control to DHW mode when system is intended for space heating may violate **Section 303 of the 2007 Energy Act**. See [page 129](#) for compliance information and exemptions.

Figure 55 Typical radiant heating system piping — circulator zoning



#### Controlling the circulators

1. The control can control up to four circulators (boiler circulator and three others). Refer to [Field wiring, beginning on page 52](#), for instructions on wiring to circulators.
2. The factory default settings are: all three inputs are set up for Space Heating (Priority 2). Each input correlates to its respective circulator output. For DHW Priority applications, wire aquastat to Input 1 and assign to Priority 1. See [Field wiring instructions, beginning on page 52](#), for details.
3. For more than 3-zones, use Weil-McLain WMCR zone Circ controller.

### Legend — Figure 55

- |  |  |   |   |
|--|--|---|---|
| 1 ■ Evergreen boiler   | 9 Air separator.   | 23 Backflow preventer, if used.                                     | 31 System supply and return sensors: Strap system sensors to lines as shown, at least 6 pipe diameters (but no more than 3 feet) from boiler connection tees. |
| 2 Indirect water heater, if used   | 10 Flow/check valves or spring check.                                      | 24 Zone circulators.  | 32 Low Water Cut-off  |
| 3 ■ Relief valve, supplied with boiler, field piped — MUST be piped to boiler supply connection — see <a href="#">page 41</a> for information. | 11 Purge/drain valves (one drain valve is supplied loose with the boiler). | 25 Pressure reducing valve, if used.                                | ■ = Items supplied with boiler — all other items supplied by installer.   |
| 4 Relief valve piping to drain — see <a href="#">page 41</a> .   | 12 Boiler circulator.  | 26 ■ Pressure/temperature gauge, supplied with boiler, field piped. |   |
| 5 DHW circulator.  | 14 Primary/secondary connection (tees no more than 12 inches apart)        | 27 Quick-fill valve, if used.                                       |   |
| 6 Isolation valves.  | 20 Make-up water supply.   | 28 Heating circuits.  |   |
| 8 Supplementary expansion tank, diaphragm type, if used.   | 22 High limit temperature control, when required by local code or          | 29 Additional heating circuits, if any.                             |   |
|  |  | 30 Mixing device, if any  |   |



# System piping - Single Boiler Systems *(continued)*

See Advanced Manual for Multiple Boiler Systems

## DHW as a zone — CIRCULATOR zoning primary/secondary See Figure 56.

1. This configuration is for circulator-zoned systems with a DHW tank piped as a zone in the system. The boiler is connected as a secondary circuit off of a primary system loop. Systems zoned with circulators must pipe the boiler loop as a secondary circuit as shown.
2. Install a separate circulator (supplied by installer) for each zone capable of delivering the proper flow and head as shown.

**CAUTION** Use at least the **MINIMUM** pipe size shown in Figure 47, page 39 on all boiler loop piping (connecting boiler to and from the primary/secondary connection, item 14). Use only primary/secondary piping as shown. Failure to follow these guidelines could result in system problems.

### Expansion Tank required

1. Provide a system expansion tank following the guidelines on page 42.
2. **DO NOT** use a closed-type tank if connecting to a water heater that is equipped with an automatic vent.

### Domestic Hot Water (DHW) tank, as shown

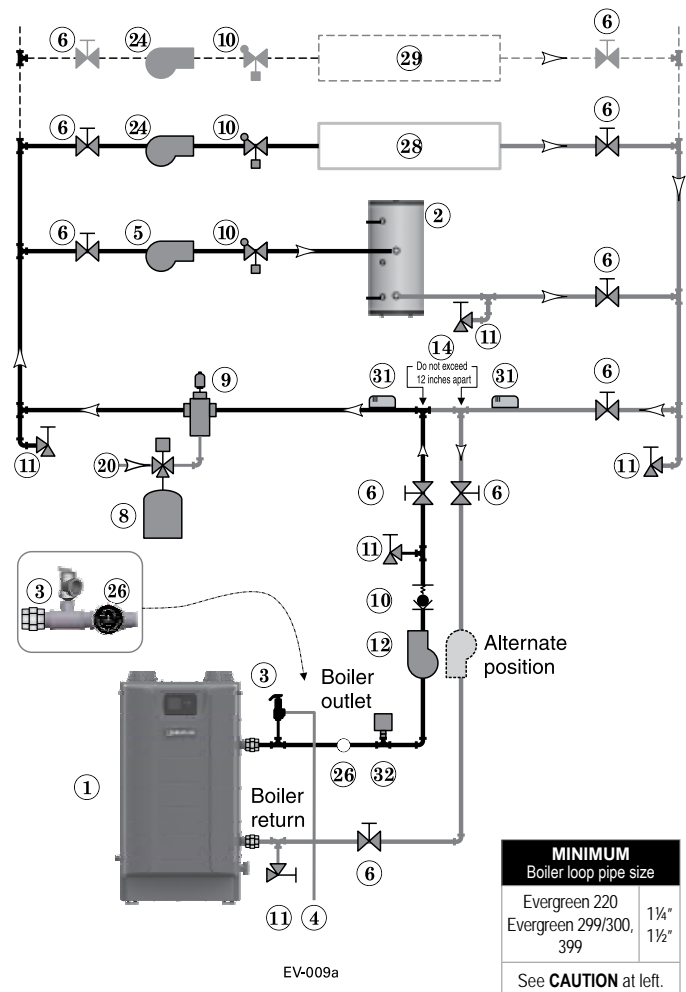
1. Install the DHW tank as a system zone. The DHW tank can be piped as a zone ONLY if a DHW tank is NOT connected to the boiler directly.
2. Wire the DHW aquastat and circulator to an input/output pair, normally Input/Output 1. See notices on page 129 to ensure compliance with the 2007 Energy Act. See the Advanced Manual to configure Boiler Pump to run during DHW demands and change TARGET MOD SENSOR to System Supply.
3. DHW Priority operation— Using Priority 1 for DHW (default) will turn off lower priorities during DHW calls. The MAX ON TIME setting can be adjusted to limit how long this occurs. Use Priority 2 or 3 for DHW if DHW priority is not desired.

**NOTICE** Overriding the Outdoor Reset function by setting control to DHW mode when system is intended for space heating may violate **Section 303 of the 2007 Energy Act**. See page 129 for compliance information and exemptions.

### Controlling the circulators

1. The control can control up to four circulators (boiler circulator and three others). Refer to **Field wiring**, beginning on page 52, for instructions on wiring to circulators.

Figure 56 Circulator zoning with DHW as a zone



2. The factory default settings are: all three inputs are set up for Space Heating (Priority 2). Each input correlates to its respective circulator output. For DHW Priority applications, wire aquastat to Input 1 and assign to Priority 1. See Field wiring instructions, beginning on page 52, for details.
3. For more than 3-zones, use Weil-McLain WMCR zone Circ controller. See EVG Advanced Manual for proper wiring.

### Legend — Figure 56

<p>1 ■ Evergreen boiler</p> <p>2 Indirect water heater, if used</p> <p>3 ■ Relief valve, supplied with boiler, field piped — MUST be piped to boiler supply connection — see page 37 for information.</p> <p>4 Relief valve piping to drain — see page 41.</p> <p>5 DHW circulator.</p> <p>6 Isolation valves.</p> <p>8 Supplementary expansion tank, diaphragm type, if used.</p>	<p>9 Air separator.</p> <p>10 Flow/check valves or spring check.</p> <p>11 Purge/drain valves (one drain valve is supplied loose with the boiler).</p> <p>12 Boiler circulator.</p> <p>14 Primary/secondary connection (tees no more than 12 inches apart)</p> <p>20 Make-up water supply.</p> <p>22 High limit temperature control, when required by local code or for a radiant system.</p>	<p>23 Backflow preventer, if used.</p> <p>24 Zone circulators.</p> <p>25 Pressure reducing valve, if used.</p> <p>26 ■ Pressure/temperature gauge, supplied with boiler, field piped.</p> <p>27 Quick-fill valve, if used.</p> <p>28 Heating circuits.</p> <p>29 Additional heating circuits, if any.</p> <p>31 System supply and return sensors: Strap system sensors to</p>	<p>lines as shown, at least 6 pipe diameters (but no more than 3 feet) from boiler connection tees.</p> <p>32 Low Water Cut-off</p> <p>■ = Items supplied with boiler — all other items supplied by installer.</p>
--	---	---	--



# System piping - Single Boiler Systems *(continued)*

## See Advanced Manual for Multiple Boiler Systems

### WATER CHILLER systems — ZONE VALVES primary/secondary

See Figure 57.

1. The chiller must be piped in parallel with the boiler.
2. Use appropriate valves to prevent chilled medium from entering boiler.
3. Circulator zoning option — The space heating system can be zoned with circulators if a separate circulator is supplied for the chilled water loop. Install a separate circulator for each zone.
4. The flow/check valve shown on the boiler outlet piping prevents gravity circulation in the boiler loop during DHW heating.

**CAUTION** Use at least the MINIMUM pipe size shown in Figure 47, page 39 on all boiler loop piping (connecting boiler to and from the primary/secondary connection). Use only primary/secondary piping as shown. Failure to follow these guidelines could result in system problems.

**NOTICE** If antifreeze is used in the system, consider the effects of antifreeze on circulator sizing and DHW performance. Some local codes may require double-wall DHW heat exchanger design. Use only the antifreeze listed by Weil-McLain for use with this boiler. See page 86 for details.

**WARNING** Chilled medium, if used, is piped in parallel with heating boiler as shown in Figure 57. Use appropriate valves to prevent chilled medium from entering boiler. If boiler is connected to heating coils located in air handling units where they can be exposed to refrigerated air, use flow control valves or other automatic means to prevent gravity circulation during cooling cycle.

#### Expansion Tank required

1. Provide a system expansion tank following the guidelines on page 42.
2. **DO NOT** use a closed-type tank if connecting to a water heater that is equipped with an automatic vent.

#### Domestic Hot Water (DHW) tank, if used

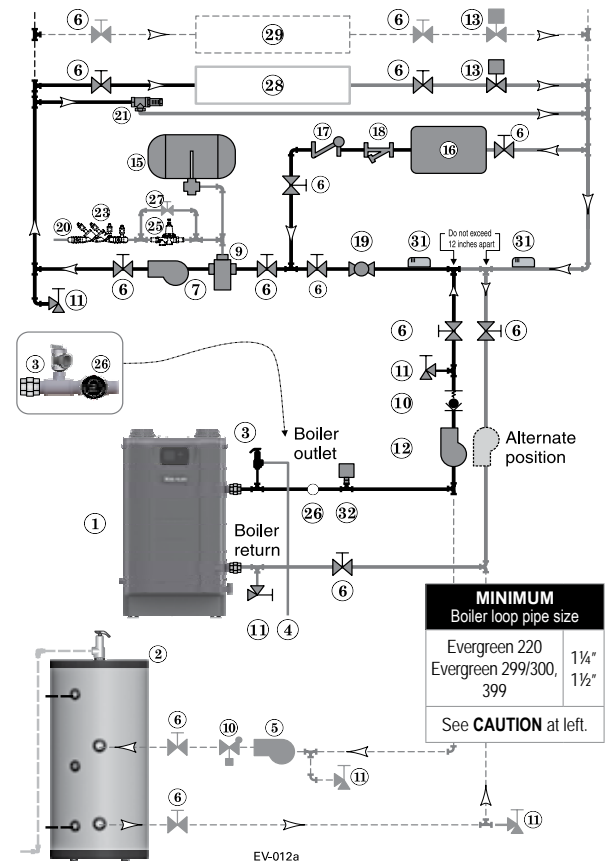
1. DHW direct connection—Pipe from the near-boiler piping to the DHW tank's boiler connections as shown.
2. DHW as zone—Not recommended for this application.
3. DHW Priority operation— Using Priority 1 for DHW (default) will turn off lower priorities during DHW calls. The MAX ON TIME setting can be adjusted to limit how long this occurs. Use Priority 2 or 3 for DHW if DHW priority is not desired.

**NOTICE** Overriding the Outdoor Reset function by setting control to DHW mode when system is intended for space heating may violate Section 303 of the 2007 Energy Act. See page 129 for compliance information and exemptions.

#### Controlling the circulators

1. The control can control up to four circulators (boiler circulator and three others). Refer to Field wiring, beginning on page 52, for instructions on wiring to circulators.

Figure 57 Chilled water system plus optional DHW piping



2. The factory default settings are: all three inputs are setup for Space Heating (Priority 2). Each input correlates to its respective circulator output. For DHW Priority applications, wire aquastat to Input 1 and assign to Priority 1. See Field wiring instructions, beginning on page 52, for details.
3. For more than 3-zones, use Weil-McLain WMZV zone valve controller.

**NOTICE** Connect zone valve end switches to Priority 2 input. Connect system circulator to CIRC 2 output.

**CAUTION** Use isolation relays if connected 3-wire zone valve end switches to the Heat inputs.

### Legend — Figure 57

1 ■ Evergreen boiler	10 Flow/check valves or spring check.	17 Check valve.	28 Heating circuits.
2 Indirect water heater, if used	11 Purge/drain valves (one drain valve is supplied loose with the boiler).	18 Y-strainer.	29 Additional heating circuits, if any.
3 ■ Relief valve, supplied with boiler, field piped — MUST be piped to boiler supply connection — see page 41 for information.	12 Boiler circulator.	19 Balancing valve.	31 System supply and return sensors: Strap system sensors to lines as shown, at least 6 pipe diameters (but no more than 3 feet) from boiler connection tees.
4 Relief valve piping to drain — see page 41.	13 Zone valves.	20 Make-up water supply.	32 Low Water Cut-off
5 DHW circulator.	14 Primary/secondary connection (tees no more than 12 inches apart)	21 By-pass pressure regulator, RECOMMENDED for zone valve systems unless other provision is made.	■ = Items supplied with boiler — all other items supplied by installer.
6 Isolation valves.	15 Supplementary expansion tank, closed type, REQUIRED for chiller systems (some chiller systems may use a diaphragm type expansion tank).	22 Backflow preventer, if used.	
7 System circulator.	16 Water chiller.	25 Pressure reducing valve, if used.	
9 Air separator.		26 ■ Pressure/temperature gauge, supplied with boiler, field piped.	
		27 Quick-fill valve, if used.	



# Install condensate line

## Prepare condensate fittings

1. Remove PVC fittings and gasket from the accessories bag.
2. Deburr and chamfer outside and inside of ½" PVC nipple to ensure even cement distribution when joining.
3. Clean nipple ends and all fittings. Dry thoroughly.
4. For each joint in the condensate line, apply the following. Assemble parts ONLY in the order given (See Figure 58).
  - a. Apply primer liberally to both joint surfaces — pipe end and fitting socket.
  - b. While primer is still damp, lightly apply approved cement to both surfaces in a uniform coating.
  - c. Apply a second coat of cement to both surfaces. Avoid using too much cement on sockets to prevent cement buildup inside.
  - d. With cement still wet, insert pipe into fitting, twisting ¼ turn. Make sure pipe is fully inserted.
  - e. Wipe excess cement from joint. Check joint to be sure a smooth bead of cement shows around the entire joint.
5. Assemble the ½" PVC nipple to the PVC reducing elbow as shown.
6. Allow joint to dry completely.
7. Then slide gasket over nipple as shown in Figure 59.
8. Slide nipple through jacket condensate line hole to position as shown in Figure 59.
9. Cement the ½" tee to the protruding ½" nipple. Be sure both nipple and reducing elbow finish upright.

**CAUTION** Firmly press the reducing elbow and the tee together while the cement sets to ensure the gasket is securely compressed. The gasket ensures the jacket enclosure is airtight at this location.

## Connect condensate trap line and fittings

1. Remove condensate trap line from bag.
2. Connecting condensate line assembly — Figure 60:
  - a. Place a hose clamp over the end of the condensate line.
  - b. Then slide the end of the trap line over the heat exchanger condensate connection.
  - c. Tighten the hose clamp to secure the trap line.
  - d. See “Fill Condensate trap with water” on page 88 for proper instructions on priming the condensate trap, if applicable at the time.
  - e. Place a hose clamp over the other end of the condensate trap line.
  - f. Slide the trap line over the reducing elbow and secure with the hose clamp.

**WARNING** Nothing is to be added to top of this tee, Figure 59.

Figure 58 Condensate trap assembly

### PVC reducing elbow

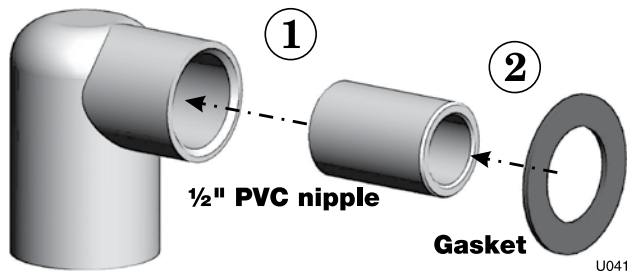


Figure 59 Condensate trap assembled into jacket

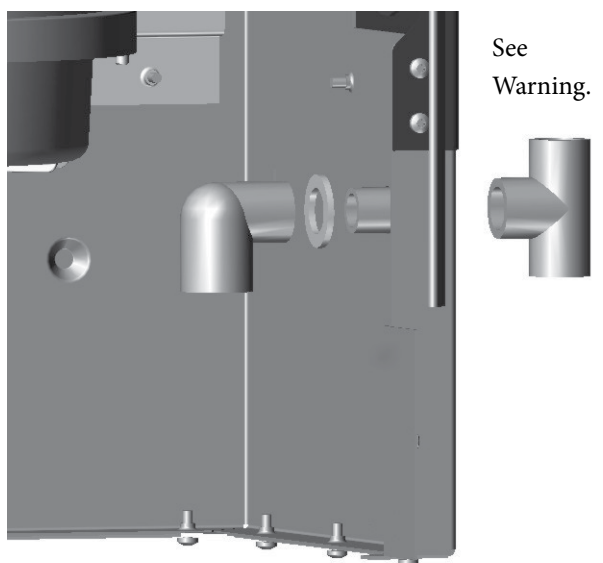
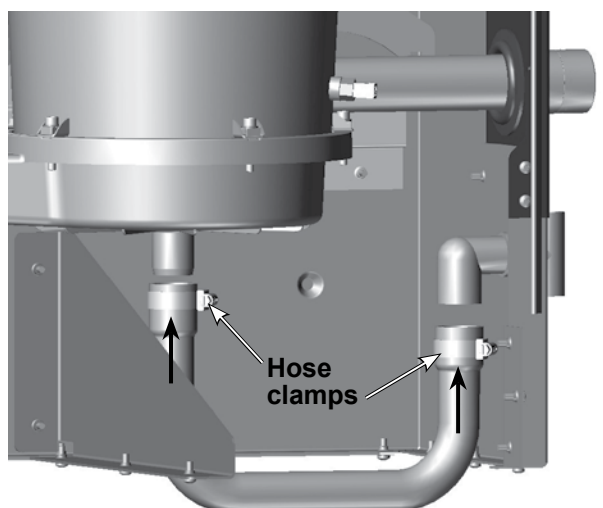


Figure 60 Condensate drain line connections





# Install condensate line *(continued)*

## Condensate drain tubing

1. Connect condensate drain tubing to the ½” PVC tee and run to floor drain or condensate pump (see [Figure 62, page 50](#)). Use ½” PVC or CPVC pipe; or 5/8” I. D. tubing (Installer supplied).

**NOTICE** Use materials approved by the authority having jurisdiction. In the absence of other authority, PVC and CPVC pipe must comply with ASTM D1785, F441 or D2665. Cement and primer must comply with ASTM D2564, F656, or F493. For Canada, use CSA or ULC certified PVC or CPVC pipe, fittings and cement.

2. Leave the top of the ½” tee OPEN. This is needed as a vacuum break. Do not install any pipe or fitting into top of tee.

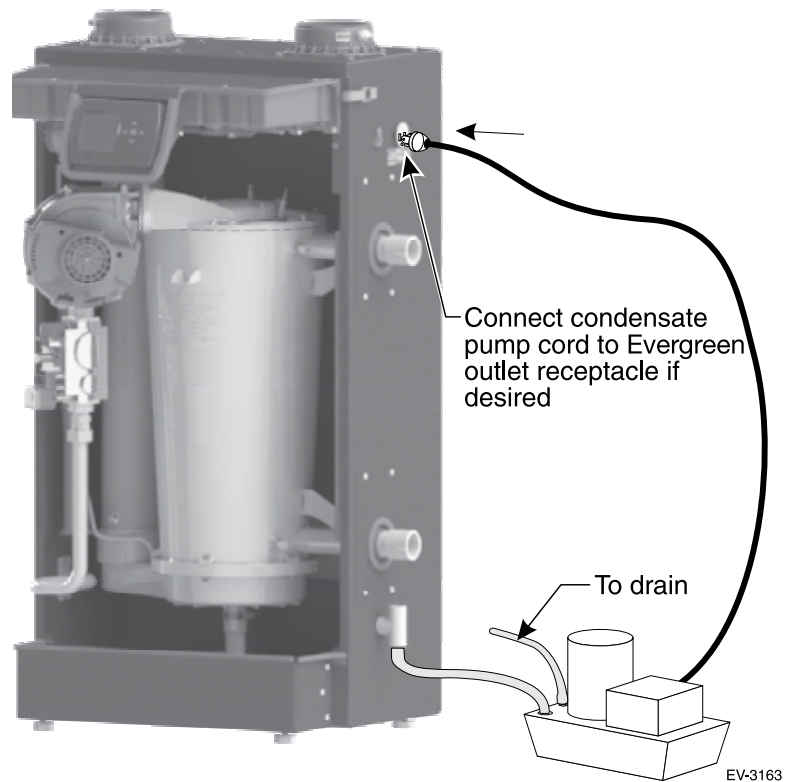
**WARNING** Nothing is to be added to top of this tee.

3. When installing a condensate pump, select one approved for use with condensing boilers and furnaces. The pump should have an overflow switch to prevent property damage from condensate spillage. See [Figure 61](#) for required flow capacity.
4. When sizing condensate pumps, make sure to include the total load of all Evergreen® boilers connected to it.

**CAUTION** The condensate line must remain unobstructed, allowing free flow of condensate. If condensate is allowed to freeze in the line or if the line is obstructed in any other manor, condensate can exit from the boiler tee, resulting in potential water damage to property.

**NOTICE** Condensate from the Evergreen® boiler will be slightly acidic (typically with a pH from 3.2 to 4.5). Install a neutralizing filter if required by local codes. See [Replacement parts](#) at the end of this manual for the Weil-McLain kit.

**Figure 62** Condensate pump (by others), typical



**Figure 61** Suggested condensate pump capacity, GPH

Boiler	Minimum recommended condensate pump capacity, per boiler, GPH
EVG 220	6
EVG 299/300	8
EVG 399	10



# Gas piping

**⚠WARNING** Evergreen® boilers are shipped ready to fire natural gas ONLY. You must install the propane venturi kit if the boiler will be connected to propane. See page 12. Failure to comply could result in severe personal injury, death or substantial property damage.

## Gas pipe sizing

See page 18 for gas line sizing information.

## Connecting gas supply piping

1. Refer to Figure 63 to pipe gas to boiler.
  - a. Place a wrench on the gas line when tightening the gas line assembly to the boiler gas connection (item 1).
  - b. Install steel pipe fittings and factory-supplied gas cock as shown in Figure 63. All pipe fittings are supplied by the installer. The gas cock is shipped loose with the boiler.
  - c. In Canada — The gas shut-off valve (item 2) must be identified by the installer.
2. Use pipe dope compatible with propane gases. Apply sparingly only to male threads of pipe joints so that pipe dope does not block gas flow.

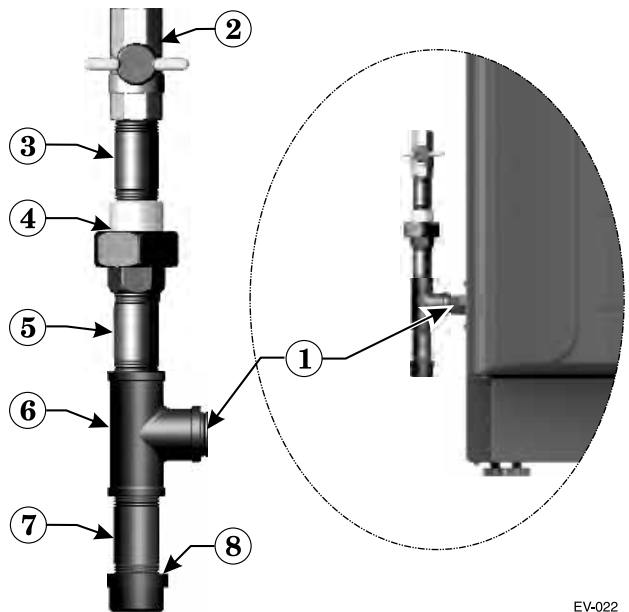
**⚠WARNING** Failure to apply pipe dope as detailed above can result in severe personal injury, death or substantial property damage.

3. Connect gas supply piping to the 3/4" NPT gas cock (item 2).
4. Support gas piping with hangers, not by boiler or its accessories.
5. Purge all air from gas supply piping.
6. Before placing boiler in operation, check boiler and its gas connection for leaks.
  - a. During any pressure testing at less than 14" (356 mm) w.c., close the gas shutoff valve and disconnect system gas piping. At higher test pressures, disconnect boiler and gas valve from gas supply piping.
  - b. After placing the boiler in operation, the ignition system safety shutoff device must be tested, page 91.
7. Install 100% lockup gas pressure regulator in supply line if inlet pressure can exceed 14" (356 mm) w.c. at any time. Adjust lockup regulator for 14" (356 mm) w.c. maximum.

**⚠WARNING** Do not check for gas leaks with an open flame — use bubble test. Failure to use bubble test or check for gas leaks can cause severe personal injury, death or substantial property damage.

**⚠WARNING** DO NOT adjust or attempt to measure gas valve outlet pressure. The gas valve is factory-set for the correct outlet pressure. This setting is suitable for natural gas and propane. Attempting to alter or measure the gas valve outlet pressure could result in damage to the valve, causing potential severe personal injury, death or substantial property damage.

**Figure 63** Connect gas supply piping



EV-022

- 1 Boiler gas supply connection, 3/4" NPT male.
- 2 T-handle gas cock, 3/4" NPT, shipped loose with boiler.

**ALL OF THE FOLLOWING ARE SUPPLIED BY THE INSTALLER:**

- 3 Nipple, 3/4" NPT
- 4 Union, 3/4" NPT
- 5 Nipple, 3/4" NPT
- 6 Tee, 3/4" NPT
- 7 Nipple, 3/4" NPT x 4", for drip leg
- 8 Cap, 3/4" NPT

**⚠WARNING** Use two wrenches when tightening gas piping at boiler, using one wrench to prevent the boiler gas line connection from turning. Failure to support the boiler gas connection pipe to prevent it from turning could damage gas line components.

## Check gas pressure at inlet to boiler

1. See Figure 88, page 91 for location of the gas inlet pressure test port.
2. For natural gas or propane, the pressure required at gas valve inlet pressure port (verify minimum gas pressure when all gas appliances are in operation):
  - a. Maximum: 14" (356 mm) w.c. with no flow (lockup) or with boiler on.
  - b. Minimum gas pressure, with gas flowing (verify during boiler startup, while boiler is at high fire) 3 1/2" (89 mm) w.c.



# Field wiring (see wiring diagram, [Figure 65, page 59](#))

**⚠ WARNING**

**ELECTRICAL SHOCK HAZARD** — For your safety, turn off electrical power supply at service entrance panel before making any electrical connections to avoid possible electric shock hazard. Failure to do so can cause severe personal injury or death.

**NOTICE**

The installation must comply with National Electrical Code and any other national, state, provincial or local codes or regulations. In Canada, CSA C22.1 Canadian Electrical Code Part 1, and any local codes.

Wiring must be N.E.C. Class 1. If original wiring as supplied with boiler must be replaced, use only type 105 °C wire or equivalent. Boiler must be electrically grounded as required by National Electrical Code ANSI/NFPA 70 – latest edition.

Do not use 24V from transformer to power any external devices that are not listed in this manual.

## Wire entrances

Eight knockouts are provided in the top of the cabinet for line and low voltage wiring. See [Figure 64](#) for locations and functions.

**⚠ WARNING**

**Installer MUST use a strain relief** through jacket knockouts. Failure to do so can cause severe personal injury, death or substantial property damage.

**⚠ WARNING**

**Installer MUST SEAL** all electrical entrances using a sealed strain relief or a strain relief sealed with duct seal putty or silicone. Sealing the entrances prevents water from entering the electrical enclosure. Failure to seal entrances could result in severe personal injury, death or substantial property damage.

## Wiring overview

See details on the following pages for the wiring connections outlined below:

### Required wiring connections

- 120VAC power to boiler; 120VAC power out to boiler circulator; system supply and return temperature sensors; and outdoor temperature sensor (unless exempt as described in this manual).

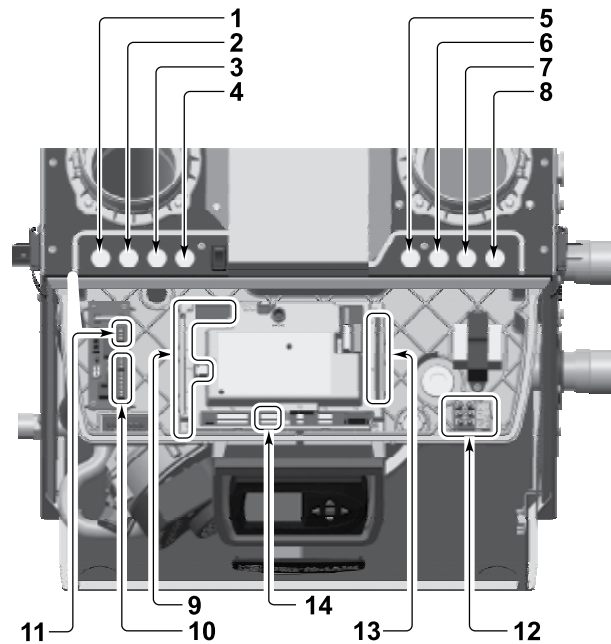
### Connections as needed by systems

- Thermostat, end switch or other inputs for call for heat.
- System zone circulators, valves, relays, etc.
- System circulator, when required.
- Low water cut-off (when required).

### Optional wiring connections

- External limits; proof-of-closure interlocks (combustion air damper, flow switch, etc.); 0–10VDC for target or modulation control; remote alarm; additional heat demand contact; and communication cables for boiler networking and/or building management system interface (MODBUS).

**Figure 64** Field wiring overview (see [Figure 65, page 59](#) and [Figure 66, page 60](#) for detailed schematic and ladder wiring diagrams)



- 1 120VAC knockout for power to boiler circulator terminals at item 11.
- 2 For wiring to P12 – Low water cutoff kit (when used) wire harness should be routed through this knockout with no other wires. Provide strain relief and a seal at cabinet entry.
- 3 & 4 Two knockouts for low voltage wires to terminal strips at items 9 and 10 (terminal strips P10, P11, P13, P14, P15 and P16). These knockouts are provided with multi-hole cord grips. Use if allowed by codes.
  - Thermostat, aquastat, limit device, outdoor temperature sensor, system temperature sensor, and boiler communication wiring should be mounted through the cord grip.
  - Mount cord grip to desired low voltage knockout and secure with a locknut before passing wire through cord grip.
  - After all wires are routed through cord grip holes and secured to connecting terminals, hand tighten the nut on top of the cord grip to seal any unused holes and grip the wires tightly.
- 5, 6, 7 & 8 Four knockouts for 120VAC wiring to power in (at item 12) and three 120VAC outputs on terminal strip (at item 13).
- 9 Low voltage connection terminal strips are shipped loose with boiler and must be plugged into receptacles on control module.
- 10 Low voltage terminal strips (P4 & P5) for connection of communication cables (multiple boiler applications).
- 11 120VAC terminal strip (P8) on Pump/Comm Board for boiler circulator power.
- 12 120VAC terminal strip (T1) for boiler power supply (15-amp breaker unless larger capacity is required for outputs connected on terminal strip P2, located at item 13).
- 13 120VAC terminal strip (P2) for outputs to circulators or auxiliary devices.
- 14 Low voltage terminal strip P7: clip jumper to wire proof-of-closure interlocks (combustion air damper, flow switch, etc.).



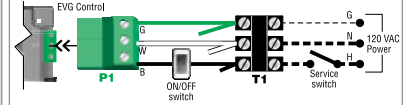
# Field wiring (see wiring diagram, Figure 65, page 59)(continued)

## A. 120 VAC Power Supply – REQUIRED

### Terminal Block T1 (control tray, right front)

- Provide and install a properly-sized, fused disconnect or service switch as required by applicable codes. (15-amp for most cases.)
  - Use table at right to determine total load. Suggested fused disconnect or service switch sizing is 15-amp if total load is 12 amps or less, 20-amp if total load is more than 12 amps.
- Connect properly sized **120 VAC** power wiring to Evergreen® boiler line voltage terminal strip T1 as shown at right.
- If possible, provide a surge suppressor in the supply power line. This will reduce the possibilities of control damage due to line surges.
- Must wire ground to this terminal to provide boiler grounding.

Determine total load	
Boiler & boiler pump (combined load)	8.4 amps
Output 1 . . . . . (2.2 amps max)	___ amps
Output 2 . . . . . (2.2 amps max)	___ amps
Output 3 . . . . . (2.2 amps max)	___ amps
TOTAL . . . . .	___ amps

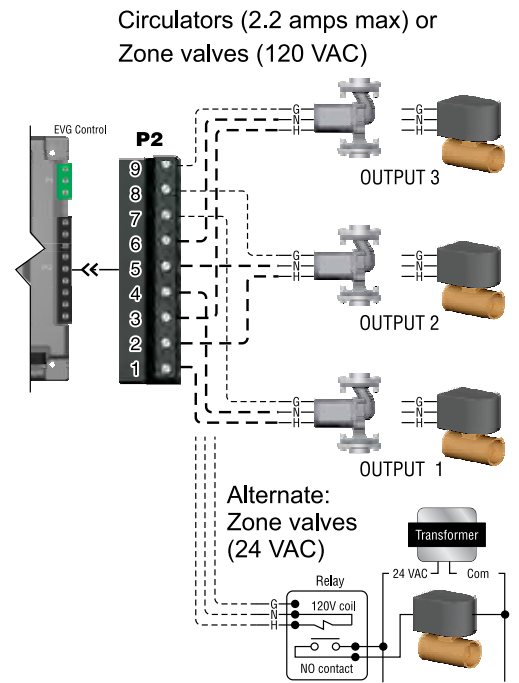


See Figure 65, page 59 for details

## B. 120 VAC Outputs 1, 2 & 3 – As needed for systems

### Terminal Strip P2 (EVG control module, right side)

- Output 1: P2 Terminals 1 (H), 4 (N), 7 (G).
- Output 2: P2 Terminals 2 (H), 5 (N), 8 (G).
- Output 3: P2 Terminals 3 (H), 6 (N), 9 (G).
- Maximum load: 2.2 amps (use relay if circulator load is higher). See WARNING below.
- These three outputs (Output 1, Output 2, and Output 3) can provide 120VAC to the following listed below.
  - A zone circulator.
  - A system circulator.
  - A DHW circulator (used to circulate through an indirect tank).
  - An auxiliary item that must be energized during an input call, such as an air damper.
- When using inputs/outputs for heat/DHW demands, each input (Input 1, Input 2, and Input 3) controls its respective 120VAC output (Output 1, Output 2, and Output 3). Outputs are energized only when BOTH conditions below are met:
  - The corresponding input indicates a call for heat/DHW (i.e. contact closure).
  - The PRIORITY assigned to the Input/Output pair is ACTIVE (i.e. the zone may be calling but the pump won't activate unless the boiler is currently running on that system/priority).
- When using the inputs/outputs for the AUX PUMP/OUTPUT function, the output is controlled by selectable conditions set up in the control.
  - Use the AUX PUMP/OUTPUT function for devices such as system pumps, combustion air dampers, and other auxiliary equipment to activate when the boiler is on/running.
  - See page 78 and page 79 for more information on the setup and selection of operating conditions.



See Figure 65, page 59 for details.

**WARNING** Output circuits are 120 VAC. If an output is to operate a low voltage circuit or must be an isolated contact, use an isolation relay.

**NOTICE** For Priority DHW Application: The DHW aquastat can be connected to any one of the three input/output pairs. The selected input should be assigned to PRIORITY 1 during the WIZARD setup or manually in the ASSIGN INPUTS menu.

**WARNING** CIRCULATOR POWER – The maximum allowable current for each circulator is 2.2 amps at 120 VAC. For circulators with higher amp ratings, install a circulator relay or starter. Connect only the 120-VAC coil to the Evergreen circulator terminals.

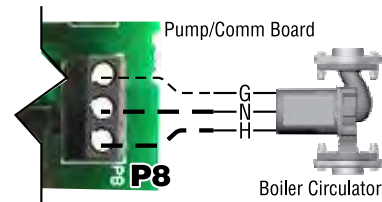


# Field wiring (see wiring diagram, Figure 65, page 59)(continued)

## C. 120 VAC to Boiler Circulator – REQUIRED

### Terminal Strip P8 on Pump/Comm Board (control tray, left side)

1. Provides 120VAC to the boiler circulator at Pump/Comm Board P8 Terminals.
2. Terminals are: 1 (H), 2 (N), 3 (G).
3. Maximum load: 2.2 amps (use relay if circulator load is higher). See WARNING above.
4. The boiler circulator (shipped loose with boiler) is used in the boiler loop of the primary / secondary piping. Primary / secondary piping is required to be used with the Evergreen<sup>®</sup> boiler to ensure proper flow through the heat exchanger.



See Figure 65, page 59 for details.

## D. Inputs 1, 2 and 3 (tstats, end switches, etc.) – As needed for systems

### Terminal Strip P11 (input 1) & Terminal Strip P15 (inputs 2 & 3) (EVG control module, left side)

1. Input 1 – Terminal Strip P11 – 4 & 5 (EVG control module)
2. Input 2 – Terminal Strip P15 – 1 & 2 (EVG control module)
3. Input 3 – Terminal Strip P15 – 3 & 4 (EVG control module)
4. These three inputs on each boiler can indicate a call for heat to the control by means of a dry contact closure (thermostat, aquastat, or switch). (See right and Figure 65, page 59).
5. The control provides inputs for up to three zones or three systems (priorities).

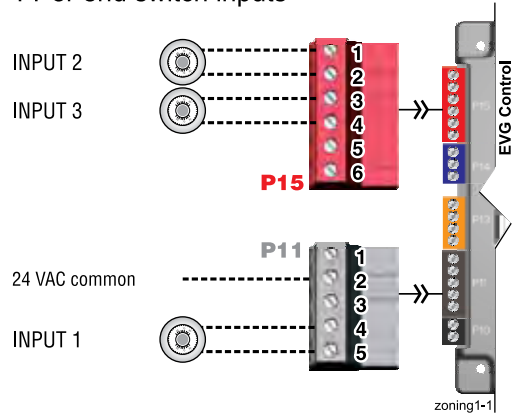
**NOTICE** The control default setting is for three space heating zones tied to PRIORITY 2, which is defaulted to FINNED TUBE BASEBOARD system type.

6. For DHW applications, the aquastat can be connected to one of the three input/output pairs. Take advantage of factory default settings by using PRIORITY 1 for the DHW system. The default control setting for PRIORITY 1 is a direct-piped DHW system type.
7. The default control setting uses each input (INPUT 1, INPUT 2, and INPUT 3) to control its respective 120VAC output (OUTPUT 1, OUTPUT 2, and OUTPUT 3).

**NOTICE** Use of 0–10VDC input for modulation disables Input 1 from creating calls for heat. See page 58 for instructions.

An input can be assigned to an AUX PUMP/OUTPUT function to operate a system pump or interlock with a combustion air damper. Inputs assigned for this function cannot be used for heat demand operation. See page 78 and page 79 for more information on the setup and selection of operating conditions.

#### TT or end switch inputs



See Figure 65, page 59 for details.

**WARNING** **Thermostats** — DO NOT supply 24-volt power to the thermostat circuits (Input1, Input2 and Input3 in Figure 65, page 59) or attempt to supply 24 volts for any other application.

For thermostats that require a continuous 24-volt power source, connect the common wire (“C”) to **P11** Pin 2 (see Figure 65, page 59). Do NOT exceed total amp draw per thermostat.

**Zone valves** — If using 3-wire zone valves, use relays to provide dry contacts to the Control thermostat connections. The zone valve end switches of 3-wire valves carry 24 VAC from the valve.

**Thermostat anticipator setting** — 0.1 amps.



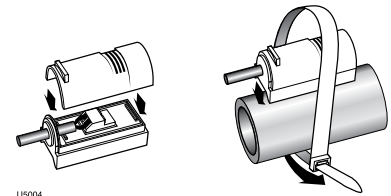
# Field wiring (see wiring diagram, [Figure 65, page 59](#))(continued)

## E. System supply and return temperature sensors – **REQUIRED**

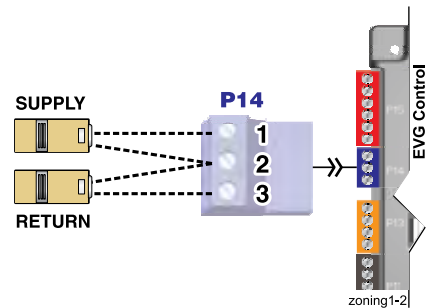
### Terminal Block P14 (EVG control module, left side)

- Two strap-on temperature sensors are shipped with the boiler. Attach one to the system supply piping and the other to the system return piping. For piping larger than 5 inch diameter or nonmetallic piping, using immersion sensors will provide faster response.
- Locate the supply sensor at least six pipe diameters, but no further than 3 feet, downstream from the boiler connection to the main to ensure adequate mixing.
- Supply sensor – wire between P14 #1 and #2 (common).
- Return sensor – wire between P14 #3 and #2 (common).
- Thermostat wire can be used to connect these sensors.
- The Control compares the system return temperature with the system supply temperature. Should the return temperature ever exceed the supply temperature, the Control knows there is likely a sensor failure and will report this problem on the display.

**NOTICE** All heating systems shown in this manual require the System Supply and Return sensors to be installed for proper control function. System will not properly provide heat if sensors are not installed according to these instructions.



Strap to supply & return piping

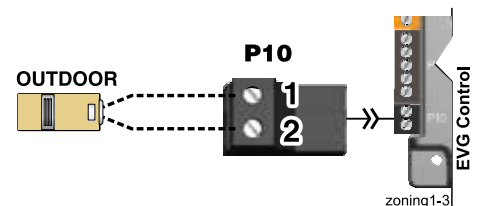


See [Figure 65, page 59](#) for details.

## F. Outdoor temperature sensor – **REQUIRED unless exempted**

### Terminal Block P10 (EVG control module, left side)

- The control provides programmable options if using an outdoor temperature sensor. This sensor is supplied with the boiler.
- The outdoor sensor must be installed unless specifically exempted in the Energy Act statement on [page 129](#).**
- Mount the outdoor sensor on an exterior wall, shielded from direct sunlight or flow of heat or cooling from other sources.
- The wire outlet on the sensor must be oriented DOWN to prevent water entry.
- Connect the sensor leads to the terminal shown at right and in the wiring diagrams (see [Figure 65, page 59](#)). Thermostat wire can be used to connect the sensor.



See [Figure 65, page 59](#) for details.

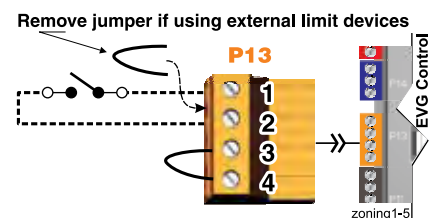
## G. External limits – **OPTIONAL**

### To cause MANUAL reset: Terminal Block P13 #1 & #2 (EVG control module, left side)

EVG control will require manual reset after circuit is interrupted.

- Remove factory-installed jumper and connect isolated contacts of external limits across P13 pins 1 and 2 to cause the control to enter manual reset lockout if the limit circuit opens. The limit must close and the control must be manually reset using the procedure given in this manual. See drawing at right and wiring diagram ([Figure 65, page 59](#)).

**NOTICE** The control will lockout when a limit in its manual reset circuit opens (P13 pins 1 & 2). The control activates its alarm terminals and shuts the boiler down. An operator (user or technician) must manually reset the control to restart the boiler.



See [Figure 65, page 59](#) for details.

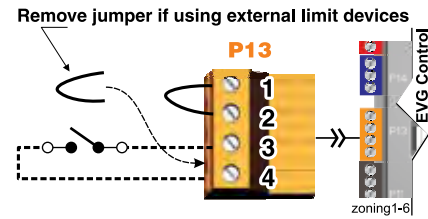


# Field wiring *(see wiring diagram, Figure 65, page 59)(continued)*

## To cause AUTOMATIC reset: Terminal Block P13 #3 & #4 (EVG control module, left side)

EVG control will reset automatically after circuit is interrupted.

1. Remove factory-installed jumper and connect isolated contacts of external limits across P13 pins 3 and 4 to cause the control to shut down the boiler on limit opening, then automatically restart 150 seconds after the limit closes.
2. See drawing at right and wiring diagram (Figure 65, page 59).



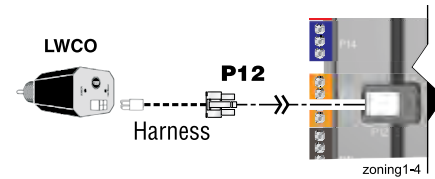
See Figure 65, page 59 for details.

## H. Low water cutoff – WHEN REQUIRED

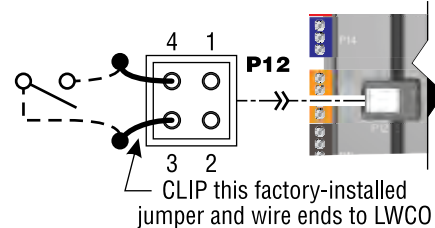
### Terminal Block P12 (EVG control module, left side)

1. Install a low water cut-off when required.
2. Wiring Weil-McLain LWCO Kit:
  - a. When possible, use the Weil-McLain Low water cut-off kit listed in the back of this manual. It includes a probe-type low water cut-off and provides a simple harness connection for the wiring.
  - b. Connect as shown at top right and in the control wiring diagram (Figure 65, page 59).
  - c. The Weil-McLain Low water cut-off kit is included with the boiler.
3. Wiring another LWCO — must have isolated contact:
  - a. Other low water cut-offs can be used with the EVG only if the device uses an isolated contact for the LWCO function.
  - b. Connect as shown at bottom right.

#### Wiring for Weil-McLain LWCO Kit



#### Wiring other isolated contact LWCO

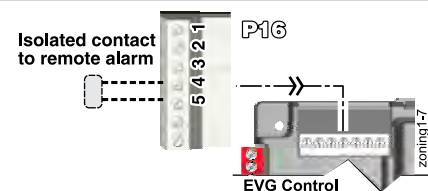


See Figure 65, page 59 for details.

## I. Alarm contacts – OPTIONAL

### Terminal Block P16 #4 & #5 (EVG control module, top left)

1. The control's alarm dry contact (P16, terminals 4 and 5) closes when the boiler enters manual lockout only.
2. Connect these terminals for remote alarm notification.
3. Contact electrical ratings: 24VAC or less; 0.5 amp or less.

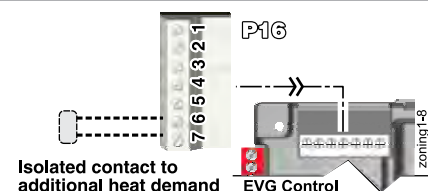


See Figure 65, page 59 for details.

## J. Additional heat demand contacts – OPTIONAL

### Terminal Block P16 #6 & #7 (EVG control module, top left)

1. The control module can be set to activate another heat source using its additional heat demand dry contacts through terminal block P16 pins 6 & 7.
2. Connect these terminals to call for heat from the other heat source.
3. Contact electrical ratings: 24VAC or less; 0.5 amp or less.
4. Set the control to activate the heat demand contacts as needed.
5. See EVG Advanced Manual to configure.



See Figure 65, page 59 for details.



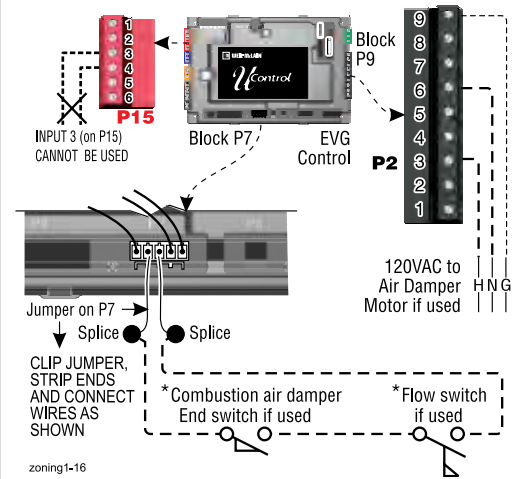
# Field wiring (see wiring diagram, Figure 65, page 59)(continued)

## K. Proof of closure (flow switch and/or CAD) – see ADVANCED Manual – OPTIONAL

### Jumper on Terminal Strip P7 (EVG control, bottom left of center)

1. A flow switch or combustion air damper (CAD) interlock can be configured by clipping the jumper on terminal strip P7 and wiring components as shown at right and in the wiring diagram (Figure 65, page 59).
2. No control settings are required when using a flow switch.
3. Recommended configuration of the EVG control for a CAD interlock:
  - a. Assign **INPUT 3** as a **AUX PUMP/OUTPUT** function.
  - b. For the **AUX PUMP/OUTPUT** operating mode, select **ANY BURNER DEMAND**. This ensures the damper will be activated any time the boiler is called on to fire.
  - c. **OUTPUT 3** will provide 120VAC to the damper motor. Use an isolation relay if damper motor requires another voltage or more than 2.2 amp if using 120 VAC.

**NOTICE** \* The devices used must provide electrically isolated contacts, because the P7 jumper circuit carries 5 VDC.

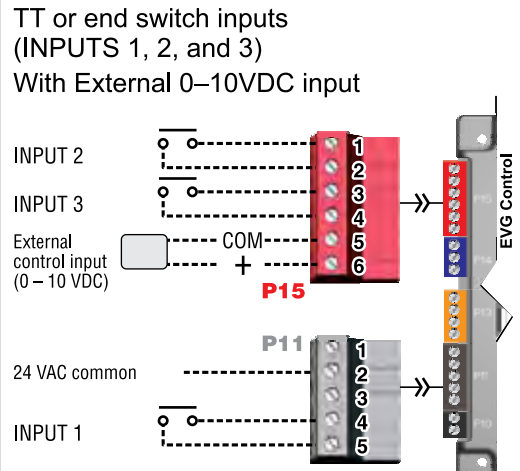


See Figure 65, page 59 for details.

## L. 0–10 VDC Remote TARGET input – OPTIONAL

### Terminal Block P15 #5 & #6 (EVG control module, left side)

1. See illustration at right and Figure 65, page 59 (wiring diagram) for details.
2. Remote target using 0–10VDC input requires a 0–10VDC input signal at P15-4/5 as shown at right.
  - a. The input positive connection must be at P15 terminal 6 and the common connection at terminal 5.
3. This illustration also shows how to connect TT or end switch contacts at INPUT 1, INPUT 2 and INPUT 3.
  - a. If a Heat/DHW demand is required, connect the demand's dry contact to an unused input on the control and its pump/valve to the respective output. Then assign and setup a priority to the input using the Wizard or manually through the contractor menu.
  - b. A dry contact heat demand must be applied to one of the inputs in order to initiate a call for heat.
4. The 0–10VDC signal is used to adjust the supply target temperature, using the TARGET ADJUST setting. Set TARGET ADJUST during the WIZARD or manually in the PRIORITY SETTINGS menu for the desired system/ priority.
  - a. Many options are available for configuring the control. The following is a suggested setup that uses factory default settings as much as possible.
  - b. Use PRIORITY 1 for the DHW heating system when used. This priority's default values are set for DHW, direct-piped to the boiler. Verify that settings are suitable for the application, change if needed.
  - c. Use PRIORITY 2 for the heating systems.
    - For single boilers, the factory default settings for PRIORITY 2 make this priority a good choice for space heating applications. Set PRIORITY 2 values to the following:
      - Set TARGET ADJUST value to 0–10V.
      - Set VOLTS FOR MAX at the voltage that will call for the highest target temperature. Set SUPPLY MAX at this temperature.
      - Set VOLTS FOR MIN at the voltage that will call for the lowest target temperature. Set SUPPLY MIN at this temperature.
      - For voltages between VOLTS FOR MAX and VOLTS FOR MIN, the target temperature will range proportionately between SUPPLY MAX and SUPPLY MIN. See the EVG Advanced Manual for a full discussion.
      - NOTE: The 0–10VDC signal replaces the ODT sensor as the target temperature modifier (TARGET ADJUST setting). The EVG control does not control target.



See Figure 65, page 59 for details.



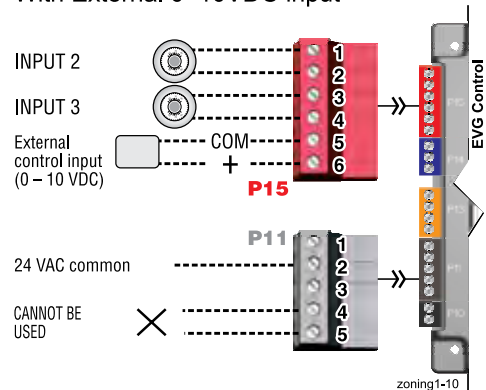
# Field wiring (see wiring diagram, Figure 65, page 59)(continued)

## M. 0–10 VDC Remote MODULATION input – OPTIONAL

### Terminal Block P15 #5 & #6 (EVG control module, left side)

1. See illustration at right and [Figure 65, page 59](#) for details.
2. This illustration also shows how to connect TT or end switch contacts at INPUT 2 and INPUT 3 for other uses.
3. Note that using 0–10VDC input replaces INPUT 1 for generating a heat demand. Do not wire any input to INPUT 1 as shown at right.
4. Remote modulation requires a 0–10VDC input signal at P15-4/5 as shown at right.
  - a. The 0–10VDC input positive connection must be at terminal 6 and common connection at terminal 5.
5. Control setup:
  - a. Many options are available for configuring the control. The following is a suggested setup that uses factory default settings as much as possible.
  - b. Default is BASIC in the Contractor menu.
  - c. If DHW is required, use PRIORITY 1 to minimize setup steps.
    - Connect the DHW aquastat to INPUT 2 or INPUT 3 and assign the input used to PRIORITY 1.
    - Verify that control settings are suitable for the application, change if necessary.
  - d. Use PRIORITY 2 for the system to be remote modulated.
    - The factory default settings for this priority are best suited for space heating.
    - Assign INPUT 1 to the priority chosen. Accept all defaults for INPUT 1 — no changes should be necessary during the WIZARD.
    - After the WIZARD has been completed, go to the ASSIGN INPUTS menu for INPUT 1. Change SOURCE to 0–10V (default setting is TT1). See [page 78](#) for ASSIGN INPUTS menu information.
6. Operation:
  - a. The boiler comes on at 0.9VDC and turns off at 0.8VDC. 1 VDC = 10% input. 10 VDC = 100% input. These voltage settings are not adjustable.
  - b. OUTPUT 1 (120VAC) is activated and deactivated as the heat demand is turned on and off. This output is a good choice to operate the system pump.
7. NOTE: The EVG control can be configured to use either 0–10VDC for target operation (see previous section) or modulation, **but not both**.

TT or end switch inputs (INPUTS 2, 3)  
With External 0–10VDC input



See [Figure 65, page 59](#) for details.

## N. 120VAC Power Receptacle

### Located on boiler right side panel

1. Electrical rating is 2.0 amps max at 120VAC.
2. This receptacle can be used to plug in a condensate pump.

## O. Multiple Boiler and BMS Connections – see ADVANCED Manual

### Terminal Strips P4 and P5 on Pump/Comm Board (control tray, left side)

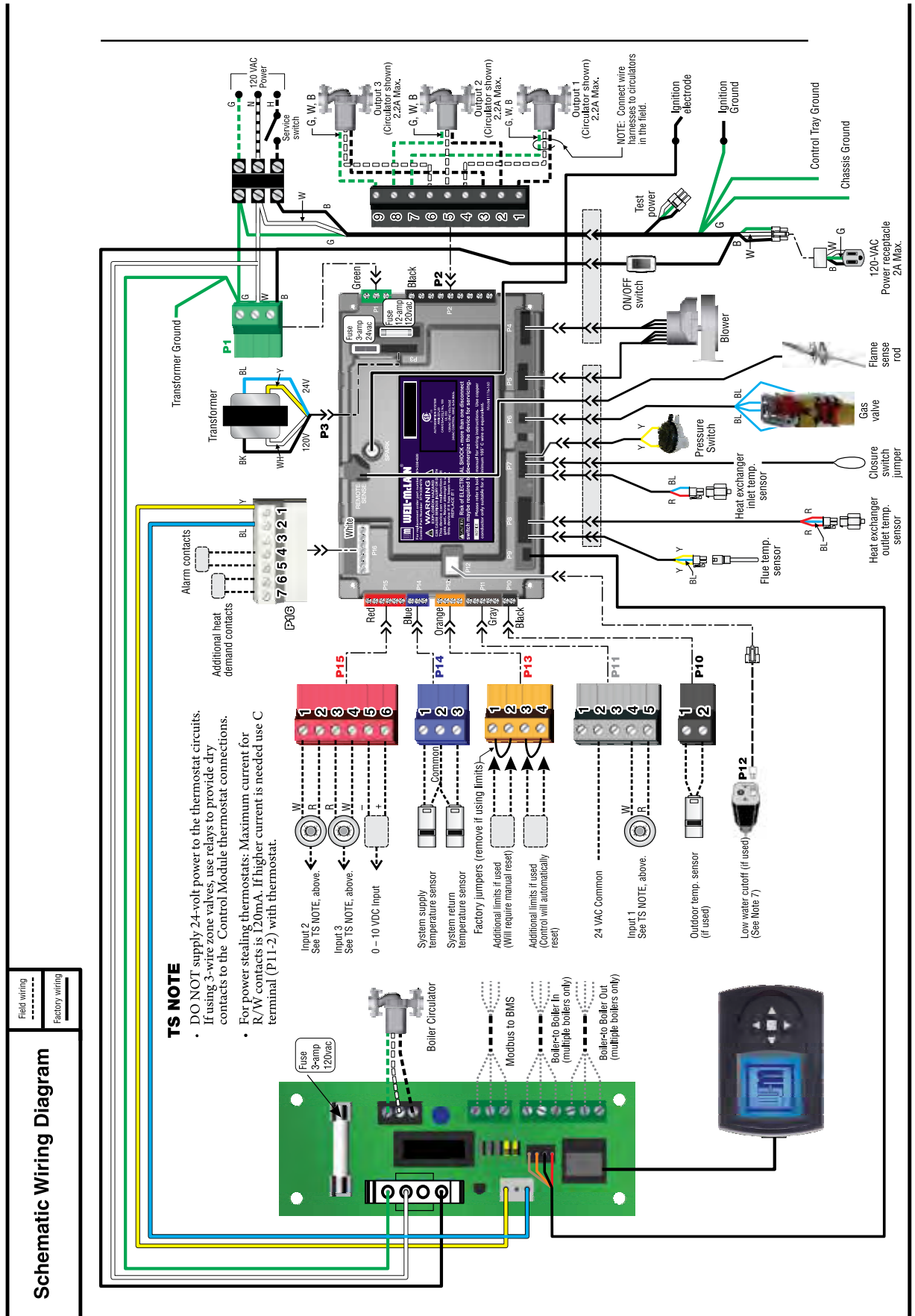
1. The boiler control is capable of multiple boiler communication and control of up to eight Evergreen® boilers in one installation.
2. The boiler control is also capable of BMS communication.
3. The boiler control is also capable ZoneStacking™:
  - Uses All boiler inputs, not just the first and last boilers, up to 24 customizable inputs across boiler network (3 per unit, maximum of 8 boilers on the network).
4. See Evergreen® Advanced Manual for multiple boiler installation and setup information.

See EVG Advanced Manual for details.



# Wiring diagram — schematic

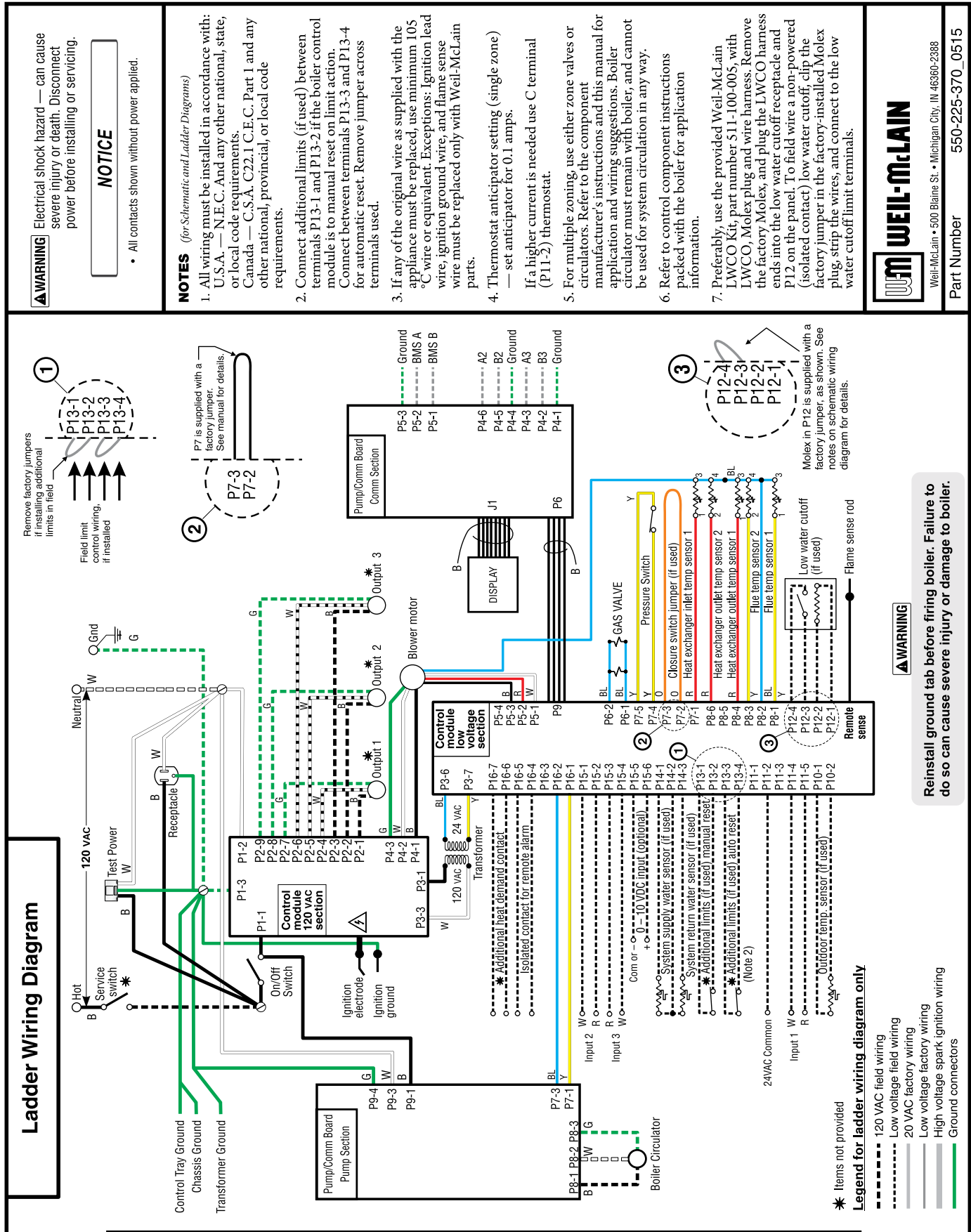
Figure 65 Evergreen<sup>®</sup> schematic wiring diagram (see Figure 66, page 60 for legend and notes)





# Wiring diagram — ladder

Figure 66 Evergreen ladder wiring diagram (see Figure 65, page 59 for schematic wiring diagram)



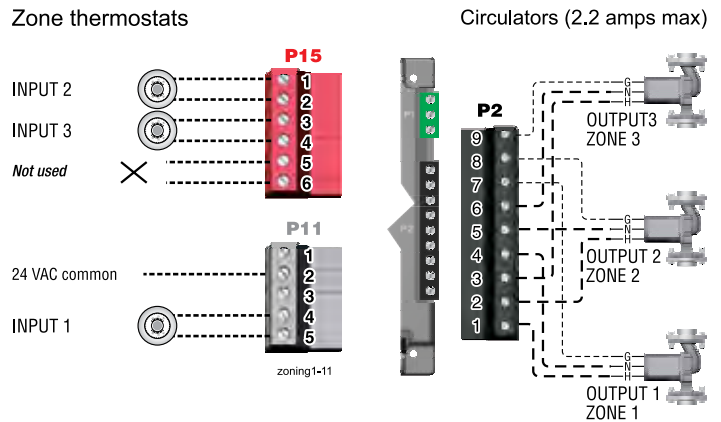


# Zoning with the EVG Control

## A. Zoning with CIRCULATORS, suggested applications

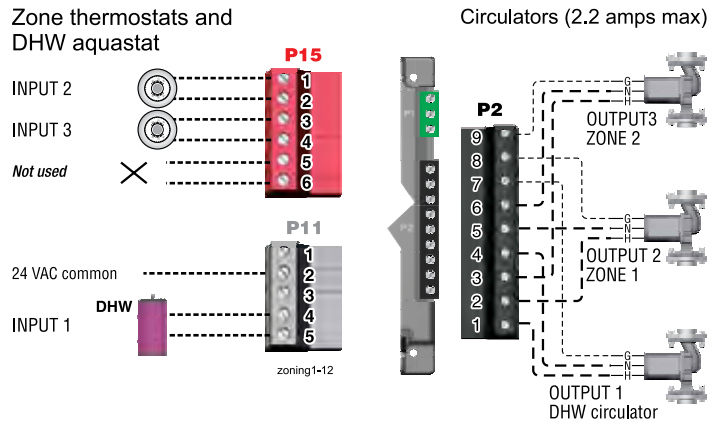
### Three space heating zones (no DHW)

1. Review wiring information on [page 53](#) (120VAC outputs) and [page 54](#) (24VAC inputs).
2. The configuration at right uses the three input/output pairs to receive thermostat inputs on P11-4/5, P15-1/2, and P15-3/4; and circulator outputs on P2 as shown.
3. The factory default settings assign all inputs 1, 2 and 3 to PRIORITY 2.
4. Choose the space heating system type that matches the heating system during the WIZARD setup or manually in the PRIORITY 2 menu.
5. Use the factory default settings for the system type chosen, or change if needed.
6. Factory defaults should work for other settings not listed above.



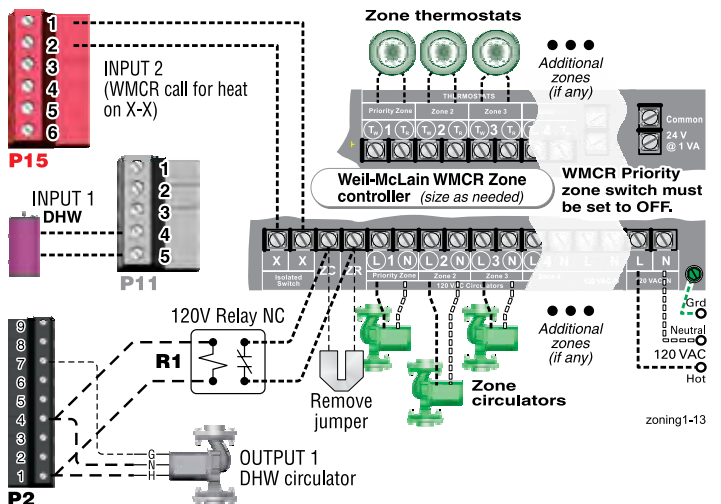
### Two space heating zones plus DHW piped directly to boiler

1. Review wiring information on [page 53](#) (120VAC outputs) and [page 54](#) (24VAC inputs).
2. The configuration at right uses INPUT 2 and 3 for space heating thermostats. INPUT 1 uses the input from a DHW aquastat.
3. The factory default settings assign inputs 1, 2 and 3 to PRIORITY 2. Keep inputs 2 and 3 assigned to PRIORITY 2. To set up PRIORITY 2, choose the space heating system type that matches the heating system during the WIZARD setup or manually in the PRIORITY 2 menu.
4. Assign INPUT 1 to PRIORITY 1, which is factory default configured for DHW applications.
5. Use the factory default settings for DHW and for the heating system type chosen, or change if needed.
6. Factory defaults should work for other settings not listed above.



### WMCR circulator zone controller plus DHW controlled by boiler, DHW piped directly to boiler

1. Review wiring information on [page 53](#) (120VAC outputs) and [page 54](#) (24VAC inputs).
2. To shut down Space Heating during DHW operation: Provide and connect relay R1 (120VAC coil with NC contact) to interrupt the Zone controller's ZC-ZR (120VAC operating circuit).
3. The configuration at right uses INPUT 2 for space heating with the call for heat coming from the zone controller (X-X). INPUT 1 uses the input from a DHW aquastat.
4. The factory default settings assign inputs 1, 2 and 3 to PRIORITY 2. Keep input 2 assigned to PRIORITY 2. To set up PRIORITY 2, choose the space heating system type that matches the heating system during the WIZARD setup or manually in the PRIORITY 2 menu.
5. Assign INPUT 1 to PRIORITY 1, which is factory default configured for DHW applications. Wire the DHW circulator to OUTPUT 1.
6. Use the factory default settings for DHW and for the heating system type chosen, or change if needed. Factory defaults should work for other settings not listed above.



P15, P11 and P2 are terminal strips on the EVG control.



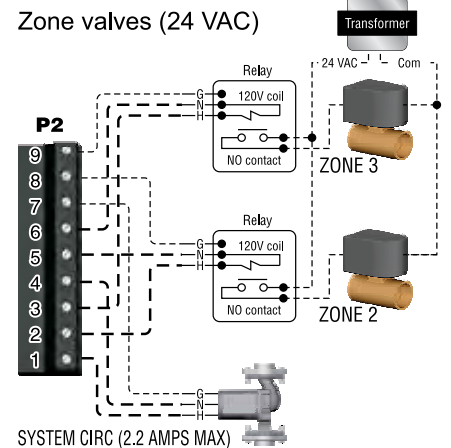
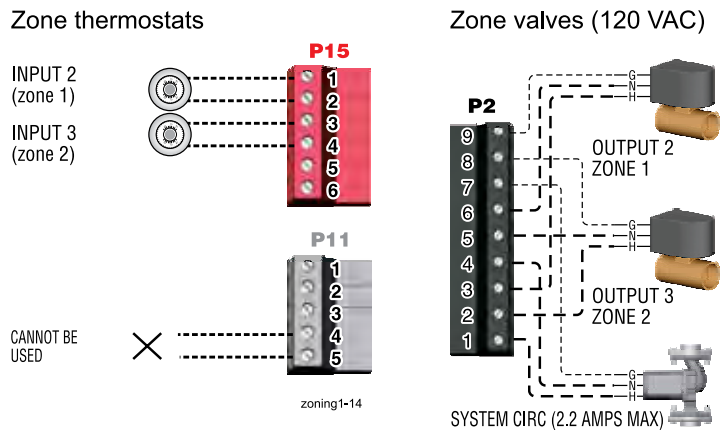
# Zoning with the EVG Control *(continued)*

## B. Zoning with ZONE VALVES, suggested applications

### Two space heating zones (no DHW)

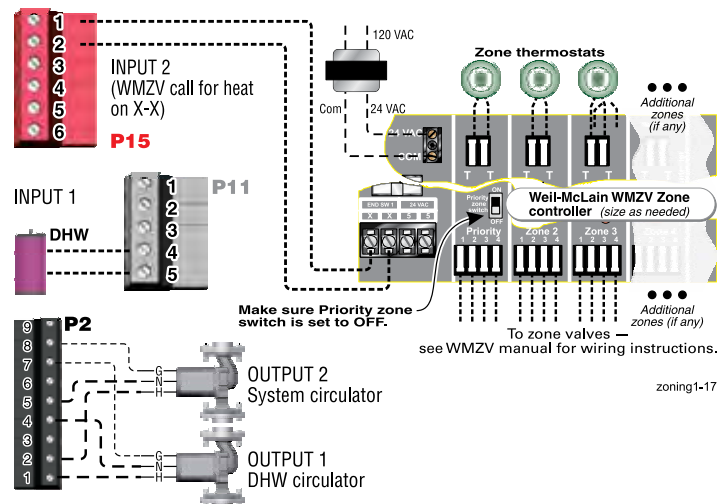
1. Review wiring information on [page 53](#) (120VAC outputs) and [page 54](#) (24VAC inputs).
2. The configuration at right uses INPUT 2 and 3 for space heating thermostats. INPUT 1 is reserved here for configuring the operation of the system circulator.
3. The factory default settings assign inputs 1, 2 and 3 to PRIORITY 2. Keep inputs 2 and 3 assigned to PRIORITY 2. To set up PRIORITY 2, choose the space heating system type that matches the heating system during the WIZARD setup or manually in the PRIORITY 2 menu.
4. Use the factory default settings for the heating system type chosen, or change if needed.
5. Assign INPUT 1 to AUX PUMP/OUTPUT. Then select ANY INPUT BY ITS PRIORITY when prompted for when to activate the output. This will cause the system pump to run when either of the zones calls for heat. Confirm that Priority 2 RUN AUX PUMP/OUT is set to YES.
6. INPUT 1 (P11-4/5) cannot be used for a wired connection (as shown at right) because it is being used in the control setup to run the system circulator.
7. Factory defaults should work for other settings not listed above.

**WARNING** The system must be equipped with a by-pass pressure regulating valve. Flow can occur with zone valves closed.



### WMZV zone valve zone controller plus DHW controlled by boiler, DHW piped directly to boiler

1. Review wiring information on [page 53](#) (120VAC outputs) and [page 54](#) (24VAC inputs).
2. The configuration at right uses INPUT 2 for space heating with the call for heat coming from the zone controller (X-X). INPUT 1 uses the input from a DHW aquastat.
3. The factory default settings assign inputs 1, 2 and 3 to PRIORITY 2. Keep input 2 assigned to PRIORITY 2. To set up PRIORITY 2, choose the space heating system type that matches the heating system during the WIZARD setup or manually in the PRIORITY 2 menu.
4. The system circulator, wired to OUTPUT 2, will turn on whenever there is a call for heat from the zone controller.
5. Assign INPUT 1 to PRIORITY 1, which is factory default configured for DHW applications. Wire the DHW circulator to OUTPUT 1.
6. Use the factory default settings for DHW and for the heating system type chosen, or change if needed. Factory defaults should work for other settings not listed above.



P15, P11 and P2 are terminal strips on the EVG control.



# Evergreen Control operation

## Evergreen control setup

1. Set control parameters using the WIZARD option provided on initial start-up or manually enter parameters using control menu (see Figure 74, page 75 and following pages for information.)
2. See **Express setup** instructions beginning on page 68 for basic systems and minimum settings required (using factory defaults).
3. This manual provides set-up information for a single boiler using BASIC control setting options. See the EVG Advanced Manual for single-boiler advanced settings and for all multiple boiler applications.

### ⚠ WARNING

#### Boiler Model, Altitude and Fuel Type are critical settings.

Failure to set correctly could result in severe personal injury, death or substantial property damage.

**Temperature settings** — You must ensure that the Evergreen control is set for the proper water temperatures for the system. Excessive water temperature can cause significant property damage in some applications.

**Multi-temperature systems** — If the heating system includes circuits that require lower temperature water (radiant slab circuits, for example) as well as higher temperature circuits (DHW, finned tube baseboard, etc.), it is recommended to protect low-temperature circuits with limit controls that are wired to an Evergreen<sup>®</sup> control external limit circuit. Failure to provide regulation can result in substantial property damage.

## Control features

- Single or multiple boiler control (with lead boiler rotation).
- Graphic and robust text display for ease of operation monitoring and troubleshooting.
- Three programmable priority assignments for up to three heat inputs.
- Preset operating parameters for typical heating systems, including target temperatures, reset curves and circulator assignments.
- Integral outdoor reset option, with reset curves matched to the system type selected.
- ModBus communications for external communication and monitoring.
- 0-10VDC input modulation or remote target input.
- Four pump outputs, including 1 boiler pump output.
- Additional heat demand operation to call a second heat source to help supply the energy required for heating.
- Advanced PI response to anticipate system needs.
- Flue temperature modifier to target temperature.
- Modulation based on flue sensor and boiler/system supply/return sensors.
- Integral low water protection by monitoring heat exchanger temp.
- Dual temperature sensors on boiler outlet and flue, providing redundant protection.
- Boiler is shipped with an outdoor sensor and strap on system supply and return sensors.
- Blower speed modulation to control boiler firing rate.
- Alarm relay on error/fault for use with an audible safety.
- ZoneStacking<sup>™</sup> – Uses All boiler inputs, not just the first and last boilers, up to 24 customizable inputs across boiler network (3 per unit, maximum of 8 boilers on the network).
- SmartSequencing<sup>™</sup> – Uses a low firing rate setting, called BASERATE LOW, to keep boilers at a low firing rate, bringing on additional boilers at reduced rate until all boilers are on if necessary. Boilers are then allowed to modulate together as high as necessary to meet demand.

## Sequence of operation

1. Figure 67 is a summary of the operating sequence for the Evergreen<sup>®</sup> control.
  - The statuses shown appear in the display as the Evergreen<sup>®</sup> control cycles the boiler. See Figure 71, page 67 for screen shots.
  - The display will flash red if a problem has been detected.

Figure 67 Control sequence of operation

Display status text	Control action <i>(also see Figure 71, page 67)</i>
<b>POWER UP</b>	<ul style="list-style-type: none"> <li>• Check the boiler model listed on the power-up screen. If it is not correct, turn off the boiler. See page 76 for instructions to change setting.</li> <li>• When power is turned on, the screen lists sensors that are detected. If any sensor is not listed, make sure it is connected correctly. Turn off power and restart.</li> </ul>
<b>Standby</b>	<ul style="list-style-type: none"> <li>• Standby - no calls for heat.</li> <li>• Toggles through no dots, 1 dot, 2 dots, then 3 dots while in standby (wrench symbol will show instead if maintenance is needed).</li> </ul>
<b>Blower ON</b>	<ul style="list-style-type: none"> <li>• Call for heat detected.</li> <li>• Display on with BLUE light (space heating) or PURPLE light (DHW).</li> <li>• Start min/max timers if more than one system is calling - highest priority starts first.</li> <li>• Start circulators for this priority setup based upon settings.</li> <li>• Calculate target temp — If sensor temp is below target temp, begin firing sequence.</li> <li>• Blower to ignition speed for prepurge.</li> </ul>
<b>Ignition</b>	<ul style="list-style-type: none"> <li>• After prepurge times out, begin ignition cycle.</li> <li>• Activate gas valve and ignition spark.</li> <li>• Continue ignition spark for ignition period.</li> <li>• Turn off spark and use electrode to check for flame signal.</li> </ul>
<b>Space Heating</b>	<ul style="list-style-type: none"> <li>• Flame detected.</li> <li>• Release boiler to modulation.</li> <li>• NOTE: If flame is not detected, the gas valve is turned off, blower turns on (postpurge), and control starts cycle again. After 5 failures, the control waits 60 minutes, then tries again.</li> <li>• If priority timer times out, switch to next priority and start priority timer.</li> <li>• If demand satisfied, go to postpurge.</li> </ul>
<b>DHW Heating</b>	<ul style="list-style-type: none"> <li>• Flame detected.</li> <li>• Release boiler to modulation.</li> <li>• NOTE: If flame is not detected, the gas valve is turned off, blower turns on (postpurge), and control starts cycle again. After 5 failures, the control waits 60 minutes, then tries again.</li> <li>• If priority timer times out, switch to next priority and start priority timer.</li> <li>• If demand satisfied, go to postpurge.</li> </ul>
<b>Blower OFF</b>	<ul style="list-style-type: none"> <li>• Demand satisfied (temperature reaches target temperature or limit setting).</li> <li>• Gas valve off.</li> <li>• Blower to ignition speed for postpurge.</li> <li>• Return to standby after purge.</li> </ul>
<b>Maintenance</b>	<ul style="list-style-type: none"> <li>• Display turns BLUE, toggling between graphic screen and maintenance screen (occurs if maintenance schedule timer times out).</li> <li>• Will show during standby only.</li> <li>• Boiler operates as normal.</li> </ul>
<b>Error/fault</b>	<ul style="list-style-type: none"> <li>• Display turns RED due to error or limit event.</li> <li>• Flashing display means lockout condition.</li> </ul>
<b>WWSD</b>	<ul style="list-style-type: none"> <li>• Warm weather shut down - the boiler will not be allowed to fire on space heating if the outside temperature is greater than the WWSD setting.</li> <li>• DHW operation is not affected by WWSD.</li> </ul>



# Evergreen Control operation *(continued)*

## EVG control Priorities & Input/Outputs

- For heating installations with multiple systems, the EVG control uses PRIORITIES to determine the order of operation of the systems. The control's MAX and MIN time settings determine the maximum and minimum times a system will be operated before being turned off to allow another system to operate. A typical example is DHW priority — heat demand from the DHW system is given preference over space heating, if set to use Priority 1.
- Each PRIORITY has its own set of operating parameters. The control prompts the user to select the system type (finned tube baseboard, DHW, etc.) and is factory programmed with parameters suited to each of these system types. The user can also choose CUSTOM to create a system type.
- The EVG control provides up to three priorities for single boiler applications and up to four priorities for network boiler applications. The order of operation is: PRIORITY 1, PRIORITY 2, PRIORITY 3.
- The 120VAC power output to the boiler circulator is provided by a relay located on the boiler's Pump/Communications Board. For each of the priorities, the control can be setup to run the boiler pump or to leave it off. It is recommended to set Blr Circ to OFF for DHW that is directly piped with its own DHW Circ.
- Each boiler has three input/output pairs (INPUT/OUTPUT 1, 2 and 3). Control setup prompts the user to assign each of these I/O pairs to a PRIORITY. The EVG control then knows which system (priority) to operate when the input receives a call for heat. On a call for heat to an input, the EVG control closes the corresponding output (120VAC) and begins controlling the boilers according to the setup for the assigned priority.
- The MAX ON TIME setting controls the maximum time a priority will be allowed to run before switching to a lower priority's call for heat. The MIN ON TIME setting controls the minimum time a priority will be operated before switching to a higher priority's call for heat, or the next lower priority.
- When multiple inputs are set up on the same priority, they will run at the same time if the priority and inputs are active.

## Evergreen control operation

- The control responds to signals from:
  - Room thermostats.
  - DHW aquastats (if used).
  - Temperature sensors (boiler return, boiler supply, flue temperature) and, when used, system supply and system return, outdoor temperature). **For optimal performance, it is recommended to install the system supply and return sensors.**
- The control automatically adjusts blower speed (and gas flow rate) to match boiler output to space heating and/or DHW heating demand.
- The control provides three inputs and three outputs (for circulators or auxiliary devices) plus a fourth boiler circulator output.
- Outdoor reset must be used in all applications that are not exempt as described on [page 129](#).
  - The outdoor temperature is used for supply temperature reset operation and for the warm weather shut down (WWSD) option.
- System presets:
  - The Evergreen control provides presets by system type (see [Figure 73](#), [page 74](#) for complete list).

Setting Up the Boiler	
<b>Step 1</b>	<ul style="list-style-type: none"> <li>• DETERMINE input/output needs –</li> <li>• What are the inputs? – Thermostats, remote contacts, end switches, etc.</li> <li>• What does each control's output need to do? – operate a pump, activate an air louver, etc.</li> </ul>
<b>Step 2</b>	<ul style="list-style-type: none"> <li>• Connect wiring to the control inputs and outputs to accomplish the purposes set in Step 1.</li> </ul>
<b>Step 3</b>	<ul style="list-style-type: none"> <li>• Install the boiler following all instructions in the Evergreen Boiler Manual before proceeding further.</li> <li>• See the Advanced Manual for multiple boiler installations.</li> <li>• Follow instructions in the Boiler Manual to start up and power the boiler.</li> </ul>
<b>Step 4</b>	<ul style="list-style-type: none"> <li>• Use the WIZARD (below) or enter control parameters manually (skip Wizard).</li> </ul>

## Evergreen control WIZARD

- The Wizard is available on initial setup of the boiler. It leads through a step-by-step setup procedure designed for the application chosen.
- Context-sensitive help is available to explain the purpose of key setup items.
- Advanced settings for single boiler applications can be accessed manually from the Contractor menu.

WIZARD Sequence	
<b>Boiler Settings</b>	<ul style="list-style-type: none"> <li>• Altitude – <b>⚠WARNING</b> – must be set correctly for proper operation.</li> <li>• WWSD – set outdoor temperature above which space heating will be deactivated.</li> <li>• Fuel (natural gas or propane) – <b>⚠WARNING</b> – must be set correctly for proper operation – control will pause until this value is selected.</li> </ul>
<b>Inputs/Outputs</b>	<ul style="list-style-type: none"> <li>• Select the usage of inputs 1, 2 and 3.</li> <li>• Determine usage of outputs 1, 2 and 3 (outputs correspond to inputs).</li> </ul>
<b>Set Priorities</b>	<ul style="list-style-type: none"> <li>• Assign priorities 1, 2 and 3 to the inputs.</li> </ul>
<b>System Settings</b>	<ul style="list-style-type: none"> <li>• Set system settings or leave at their defaults.</li> </ul>
<b>System Types</b>	<ul style="list-style-type: none"> <li>• Specify what system type is connected to each of the three outputs; each system type causes the control to preset. operating temperatures.</li> </ul>
<b>Output Activation</b>	<ul style="list-style-type: none"> <li>• (When applicable) Select when to activate AUX PUMP/ OUTPUT – by input, always on, external switch, etc.</li> </ul>
<b>Priority Switching</b>	<ul style="list-style-type: none"> <li>• Set maximum and minimum timings for priorities.</li> </ul>
<b>Date/Time</b>	<ul style="list-style-type: none"> <li>• Set date and time – important for control diagnostic logging.</li> </ul>
<b>Information</b>	<ul style="list-style-type: none"> <li>• Set installer name and contact information.</li> <li>• Enter CP#, install date, maintenance date, etc.</li> <li>• Set automatic maintenance notification timing.</li> </ul>



# Evergreen Control operation *(continued)*

## Outdoor reset operation

1. Set desired temperatures for space heating zones.
2. For an explanation of the target temperatures and associated outdoor temperatures, see Figure 68.
3. The temperature settings discussed below are accessed in the priority menu for the applicable system. For detailed explanations of the priority menus, see [Figure 76, page 77](#).

### SUPPLY MAX

1. Set Supply max to the required supply water temperature for the system at design maximum heat loss (typically 180°F for finned tube baseboard on new installations).

### SUPPLY MIN

1. Supply min should equal the desired minimum supply water temperature for the system.
2. This could be set as low as 70°F, which would supply “zero heat” when outdoor temperature is 70°F, because supply water temperature would equal room temperature.
3. See examples in Figure 68.

### OD RESET MAX

1. OD RESET MAX means the outdoor temperature at which the target temperature reaches its minimum (Supply min).
2. In the examples of Figure 68, this occurs at 70 °F (the factory default).

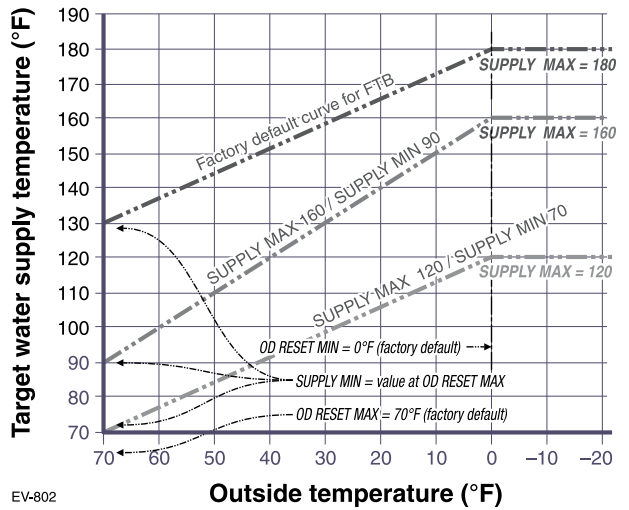
### OD RESET MIN

1. OD RESET MIN means the outdoor temperature at which the target temperature reaches its maximum value (Supply max).
2. In the examples of Figure 68, this occurs at 0°F outside (the factory default setting).
3. OD RESET MIN should equal the ODT (outdoor design temperature) for the installation’s location.

## Remote target operation (0–10VDC input)

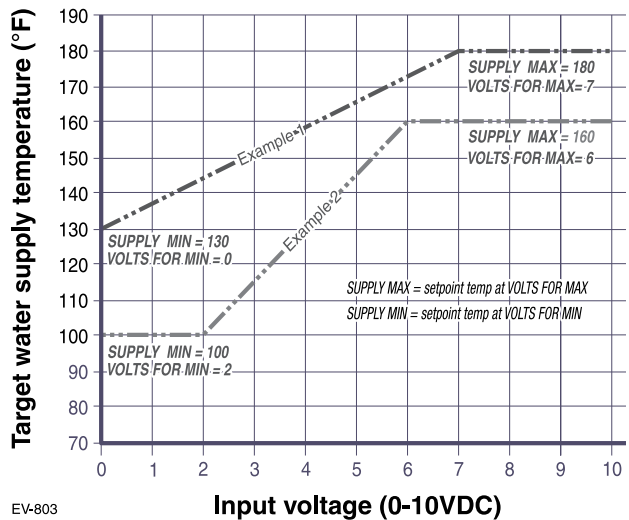
1. This function allows a remote analog input to regulate the supply temperature for control operation/modulation. This can be done for any priority, including network and local priorities for multiple boiler networks.
2. The settings discussed below are accessed in the priority menu for the applicable system. For detailed explanations of the priority menus, see [Figure 76, page 77](#).
3. See Figure 69 for an explanation of target temperature vs voltage when using remote target operation.
4. In the priority menu for the applicable system, select 0-10v for the TARGET ADJUST setting.
5. In the same priority menu, select the VOLTS FOR MIN and VOLTS FOR MAX values. VOLTS FOR MIN sets the voltage value for the desired minimum supply temperature. VOLTS FOR MAX sets the voltage value for the desired maximum supply temperature.

Figure 68 Outdoor reset operation



EV-802

Figure 69 Remote target operation



EV-803

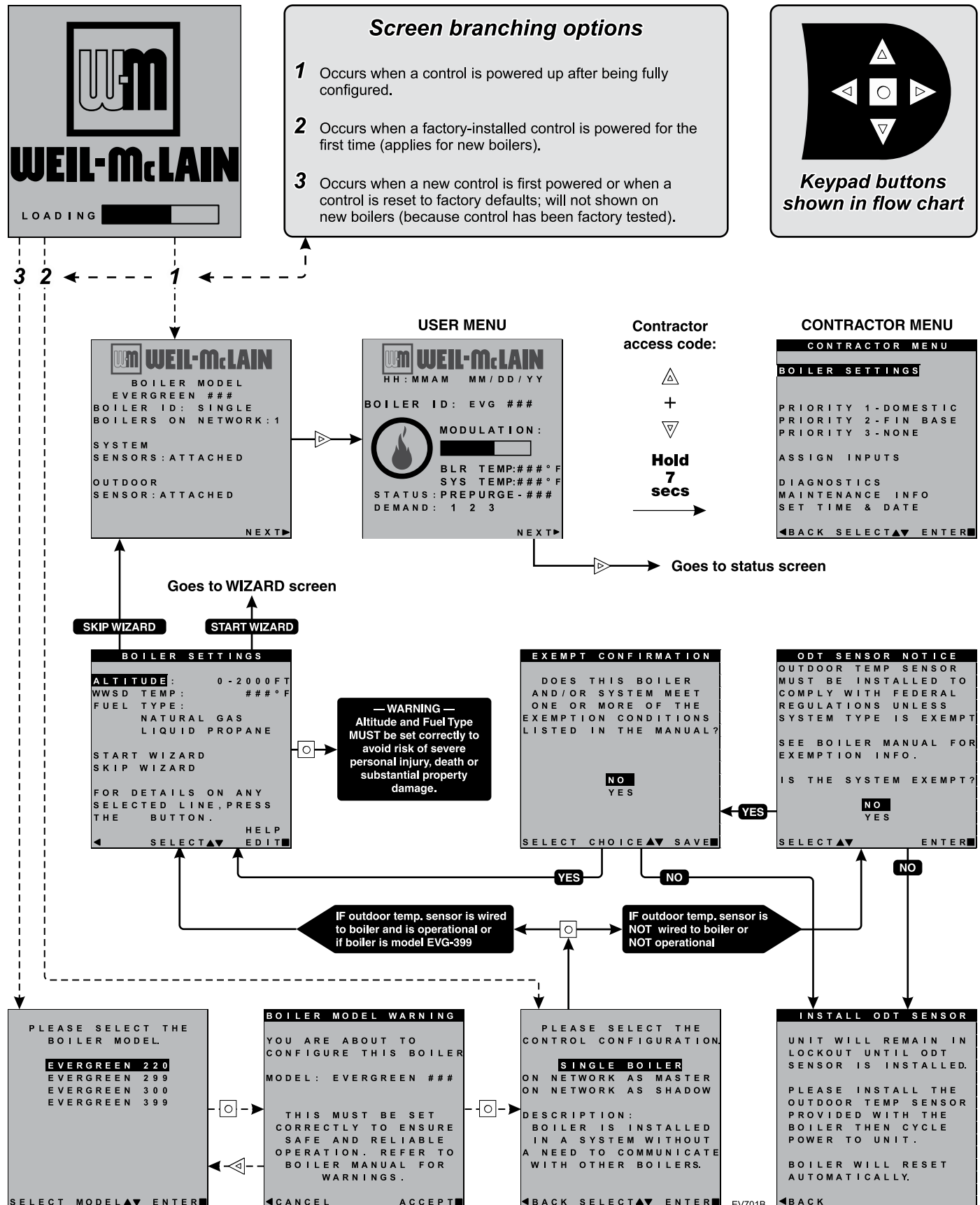
## Remote modulation operation (0–10v input)

1. To use 0-10VDC for remote modulation, go to Contractor Menu -> Assign Inputs. Then change Input 1’s source to 0-10V. The priority that is assigned to Input 1 cannot be used by any other Input.
2. The boiler comes on at 0.9VDC and turns off at 0.8VDC. 1 VDC = 10% input. 10 VDC = 100% input. These voltage settings are not adjustable.



# Evergreen Control operation *(continued)*

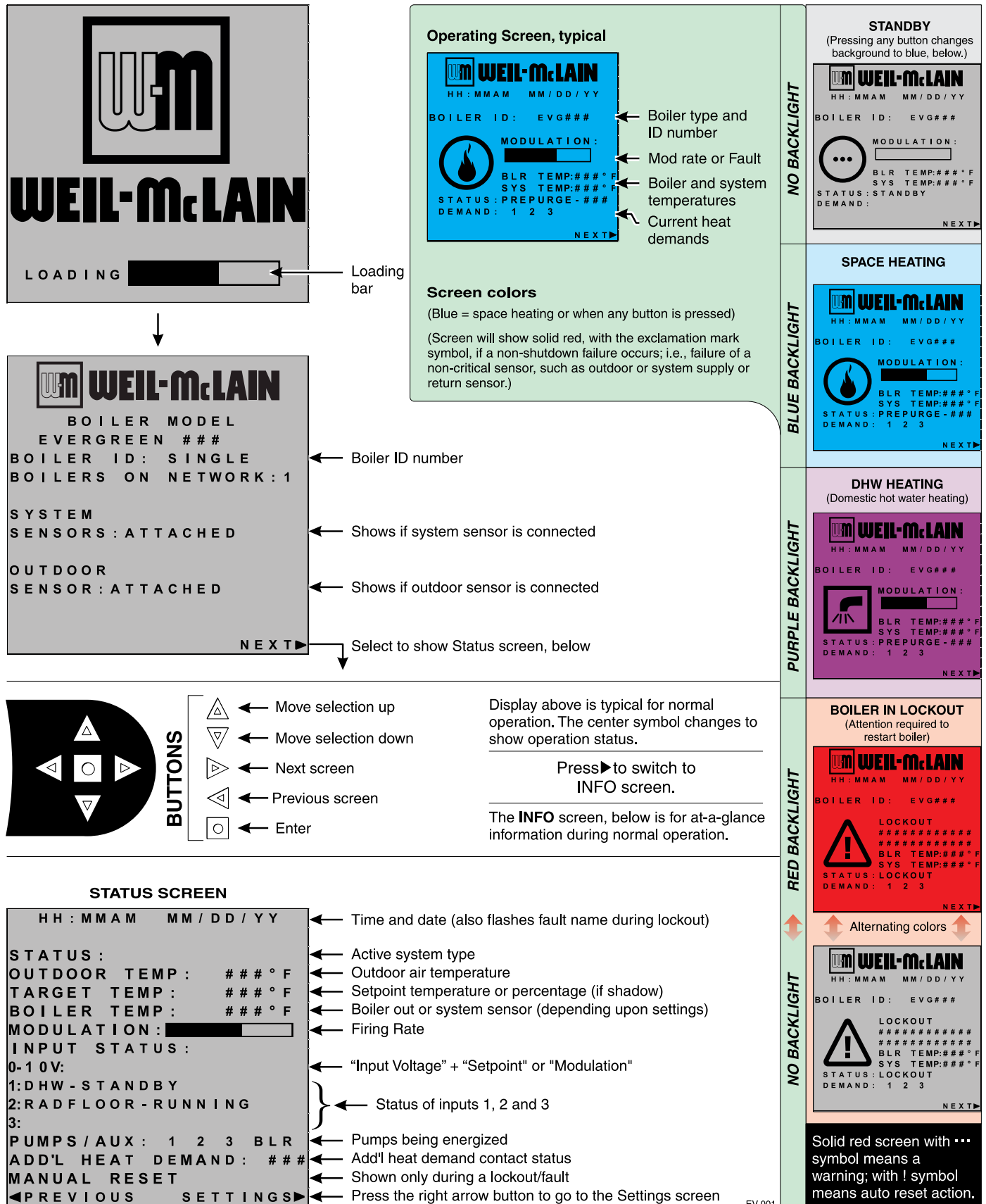
Figure 70 Evergreen single boiler essential settings (REQUIRED on initial start-up) — see page 74 for explanation





# Evergreen Control operation *(continued)*

Figure 71 Evergreen control display screens and typical navigation





# EXPRESS SETUP — EXAMPLE A

Multi-zone SPACE HEATING (Circulators with circulator relays) | DHW (Direct-piped)

**⚠️ WARNING**

**Boiler Model, Altitude and Fuel Type are critical settings.** Failure to set correctly could result in severe personal injury, death or substantial property damage.

Incorrect setup or piping can result in severe personal injury, death or substantial property damage.

Use primary/secondary piping or equivalent ONLY. **Do not use direct-connect system piping.**

Verify that the correct system type is selected on the control and that operating temperature settings are suitable for the system. System and structural damage can occur if temperatures are too high.

## Purpose

- Space heating with multiple zones.
- Zoning with circulators using circulator relays.
- DHW piped directly to the boiler.
- DHW priority — space heating is disabled during call for heat from water heater.

## Control setting notes

- See the table at right for required and optional settings.
- The sequence in the table follows the WIZARD.
- If not using the WIZARD, follow instructions elsewhere in this manual to enter the settings manually.

## Circulators and piping

**⚠️ WARNING**

Provide an external relay and external power to any circulator if its load rating exceeds 2.2 amps FLA, 3.6 amps locked rotor, or 16.4 amps in rush.

- Piping must be primary/secondary as shown.
- DHW circulator must be selected to handle the pressure drop through the boiler, water heater and piping. DHW circulator supplied by installer.
- For some large indirect water heaters, the required flow rate may require piping the water heater differently.
- The control settings in table at right provide DHW priority — space heating will be discontinued during a call for DHW.
- Zone circulators and relays supplied by installer. For alternate zone wiring using a zone controller, see [page 61](#).

## BOILER

- Boiler circulator shipped loose with boiler.
- Follow all instructions in this manual for piping boiler and system.

EVG CONTROL SETTINGS	
(IN ORDER OF WIZARD SEQUENCES)	
<b>BOILER SETTINGS</b>	
BOILER MODEL	Verify model number is correct
WWSO TEMP	Default (70 °F) or as required
HIGH ALTITUDE	Set to altitude if over 2,000 feet
<b>INPUT/OUTPUT 1 (Assign to PRIORITY 1)</b>	
WHAT IS THE USE OF INPUT/OUTPUT 1?	HEAT/DHW DEMAND
WHAT PRIORITY IS INPUT #1?	select PRIORITY 1
WHAT SYSTEM TYPE IS INPUT/OUTPUT 1?	DHW (D)
TARGET MOD SENSOR	BOILER OUT (D)
TARGET ADJUST	NONE (D)
SUPPLY MAX	D (or change if desired)
RUN BOILER PUMP?	NO (D)
RUN AUX PUMP/OUTPUT?	D (not applicable)
<b>INPUT/OUTPUT 2 (Assign to PRIORITY 2)</b>	
WHAT IS THE USE OF INPUT/OUTPUT 2?	HEAT/DHW DEMAND
WHAT PRIORITY IS INPUT #2?	PRIORITY 2
WHAT SYSTEM TYPE IS INPUT/OUTPUT 2?	Select correct system type
TARGET MOD SENSOR	SYSTEM SUPPLY (D)
TARGET ADJUST	ODT (D) (outdoor sensor must be installed)
SUPPLY MAX	D (or change if desired)
SUPPLY MIN	D (or change if desired)
OD RESET MAX	D (or change if desired)
OD RESET MIN	D (or change if desired)
BOOST TIME	D (or change if desired)
RUN BOILER PUMP?	YES (D)
RUN AUX PUMP/OUTPUT?	D (not applicable)
<b>INPUT/OUTPUT 3 (Not used)</b>	
WHAT IS THE USE OF INPUT/OUTPUT 3?	NONE
<b>PRIORITY SWITCH TIMES:</b>	
P1 MAX ON TIME	D (or change if desired)
P2 MAX ON TIME	D (or change if desired)
P2 MIN ON TIME	D (or change if desired)
P3 MIN ON TIME	D (not applicable)
<b>Finish the WIZARD</b>	
ENTER TIME, DATE AND MAINTENANCE INFORMATION AS PROMPTED	

**RED** — VALUE MUST BE SET OR VERIFIED  
**D** — DEFAULT ACCEPTABLE; CHANGE ONLY IF DESIRED

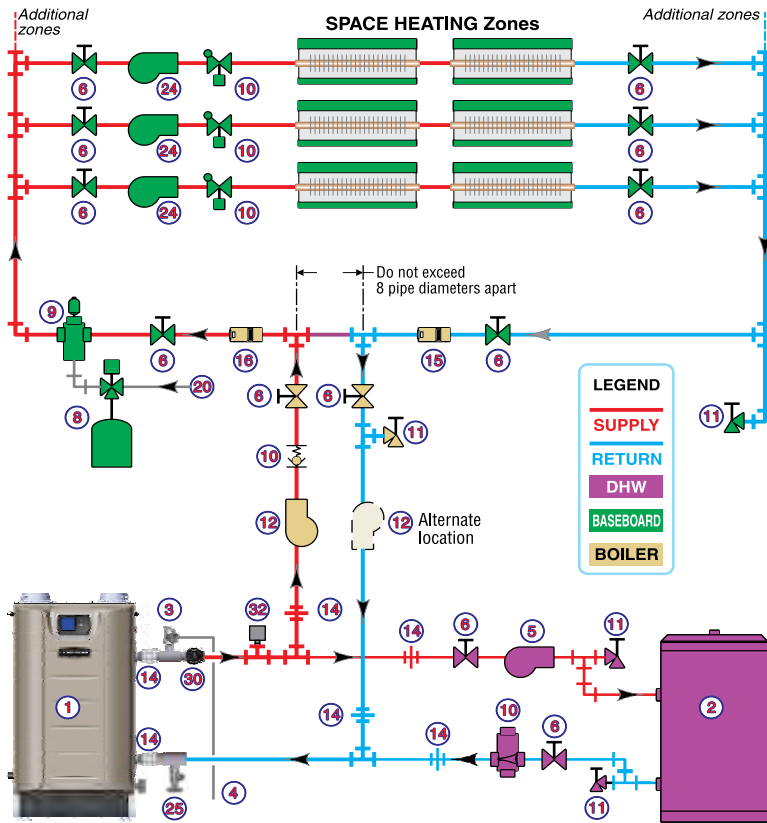
**Note 1:** If DHW is not used, set the USE of INPUT/OUTPUT 1 to NONE. Keep all other wiring as shown at right and follow all settings given above for PRIORITY 2.



# EXPRESS SETUP — EXAMPLE A *(continued)*

Multi-zone SPACE HEATING (Circulators with circulator relays) | DHW (Direct-piped)

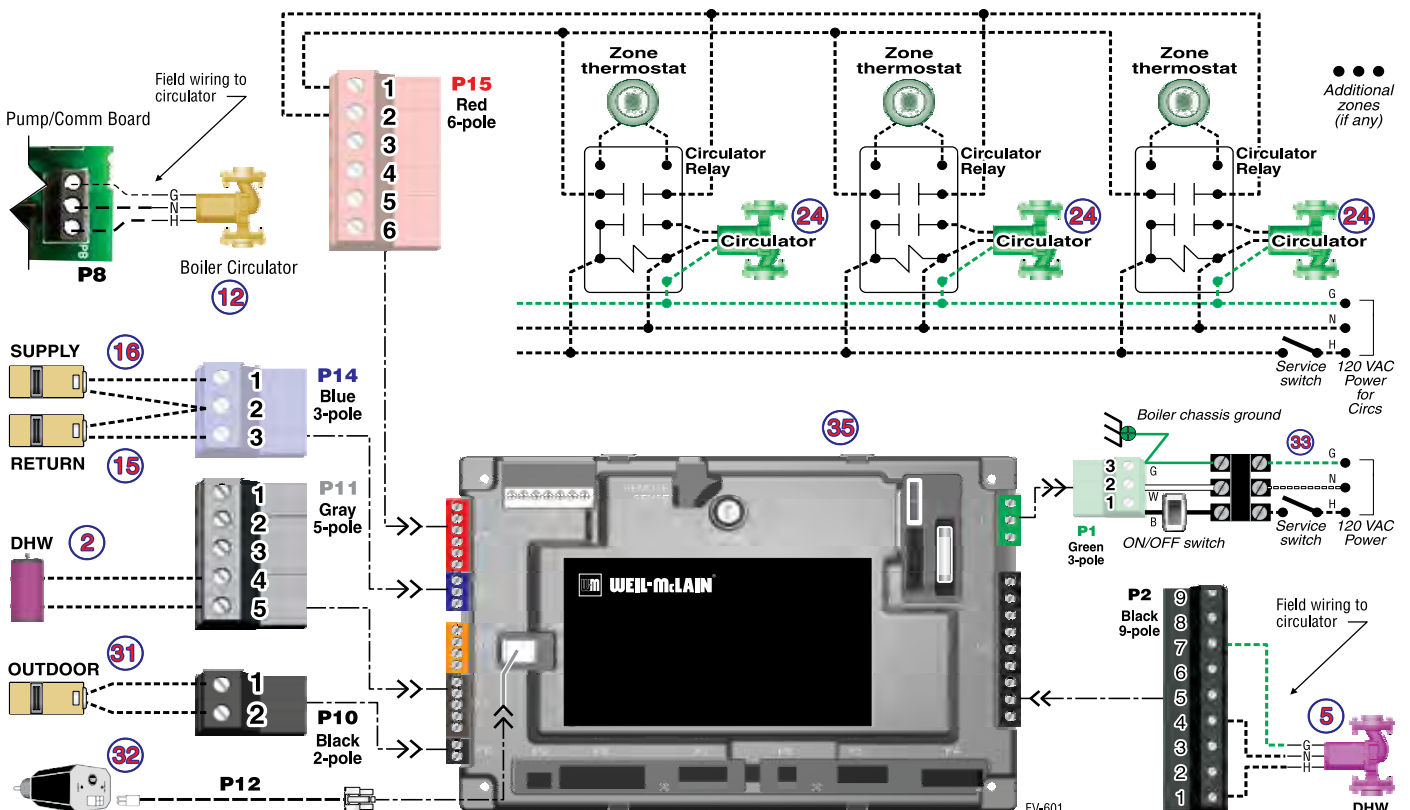
## PIPING



## LEGEND

- |   |   |
|---|---|
| 1 ■ Evergreen boiler.   | 14 Unions as needed for service.                                    |
| 2 Indirect water heater, if used (domestic water piping not shown) — <b>MUST be direct piped to boiler to use default control settings.</b>     | 15 Return temperature sensor.                                       |
| 3 ■ Relief valve, supplied with boiler, field piped — <b>MUST be piped to boiler supply connection</b> — see Figure 6, page 11 for information. | 16 Supply temperature sensor.                                       |
| 4 Relief valve piping to drain.   | 20 Make-up water supply.  |
| 5 DHW circulator.   | 24 Zone circulators.  |
| 6 Isolation valves.   | 25 ■ Boiler drain valve, supplied with boiler, field piped.         |
| 8 Expansion tank.   | 30 ■ Pressure/temperature gauge, supplied with boiler, field piped. |
| 9 Air separator.  | 31 Outdoor sensor.  |
| 10 Flow/check or spring check valves.   | 32 Low water cut-off.   |
| 11 Purge/drain valves.  | 33 120VAC power to boiler — see page 53.                            |
| 12 ■ Boiler circulator, supplied with boiler, field piped.  | 35 EVG Control module.  |
- = Items supplied with boiler — all other items supplied by installer.

## FIELD WIRING





# EXPRESS SETUP — EXAMPLE B

2- or 3-Zone SPACE HEATING (Circulators without circulator relays) | DHW (Direct-piped)

**⚠️ WARNING**

**Boiler Model, Altitude and Fuel Type are critical settings.** Failure to set correctly could result in severe personal injury, death or substantial property damage.

Incorrect setup or piping can result in severe personal injury, death or substantial property damage.

Use primary/secondary piping or equivalent ONLY. **Do not use direct-connect system piping.**

Verify that the correct system type is selected on the control and that operating temperature settings are suitable for the system. System and structural damage can occur if temperatures are too high.

### Purpose

- Space heating with multiple zones.
- Zoning with circulators using EVG control outputs to operate zone circulators (3 zones if space heating only; or 2 space heating zones plus DHW).
- DHW piped directly to the boiler.
- DHW priority — space heating is disabled during call for heat from water heater.

### Control setting notes

- See the table at right for required and optional settings.
- The sequence in the table follows the WIZARD.
- If not using the WIZARD, follow instructions elsewhere in this manual to enter the settings manually.

### Circulators and piping

**⚠️ WARNING**

Provide an external relay and external power to any circulator if its load rating exceeds 2.2 amps FLA, 3.6 amps locked rotor, or 16.4 amps in rush.

- Piping must be primary/secondary as shown.
- DHW circulator must be selected to handle the pressure drop through the boiler, water heater and piping. DHW circulator supplied by installer.
- For some large indirect water heaters, the required flow rate may require piping the water heater differently.
- The control settings in table at right provide DHW priority — space heating will be discontinued during a call for DHW.
- Zone circulators supplied by installer. For alternate zone wiring using a zone controller, see [page 61](#).

### BOILER

- Boiler circulator shipped loose with boiler.
- Follow all instructions in this manual for piping boiler and system.

EVG CONTROL SETTINGS	
(IN ORDER OF WIZARD SEQUENCES)	
<b>RED</b> — VALUE MUST BE SET OR VERIFIED <b>D</b> — DEFAULT ACCEPTABLE; CHANGE ONLY IF DESIRED	
BOILER SETTINGS	
BOILER MODEL	Verify model number is correct
WWSMD TEMP	Default (70 °F) or as required
HIGH ALTITUDE	Set to altitude if over 2,000 feet
INPUT/OUTPUT 1 (Assign to PRIORITY 1) (Note 1)	
WHAT IS THE USE OF INPUT/OUTPUT 1?	HEAT/DHW DEMAND
WHAT PRIORITY IS INPUT #1?	select PRIORITY 1
WHAT SYSTEM TYPE IS INPUT/OUTPUT 1?	DHW (D)
TARGET MOD SENSOR	BOILER OUT (D)
TARGET ADJUST	NONE (D)
SUPPLY MAX	D (or change if desired)
RUN BOILER PUMP?	NO (D)
RUN AUX PUMP/OUTPUT?	D (not applicable)
INPUT/OUTPUT 2 (Assign to PRIORITY 2)	
WHAT IS THE USE OF INPUT/OUTPUT 2?	HEAT/DHW DEMAND
WHAT PRIORITY IS INPUT #2?	PRIORITY 2
WHAT SYSTEM TYPE IS INPUT/OUTPUT 2?	Select correct system type
TARGET MOD SENSOR	SYSTEM SUPPLY (D)
TARGET ADJUST	ODT (D) (outdoor sensor must be installed)
SUPPLY MAX	D (or change if desired)
SUPPLY MIN	D (or change if desired)
OD RESET MAX	D (or change if desired)
OD RESET MIN	D (or change if desired)
BOOST TIME	D (or change if desired)
RUN BOILER PUMP?	YES (D)
RUN AUX PUMP/OUTPUT?	D (not applicable)
INPUT/OUTPUT 3 (Assign to PRIORITY 2)	
If PRIORITY 2 is assigned, no further steps are required. If PRIORITY 3 is assigned, repeat the steps from INPUT/OUTPUT 2, above.	
PRIORITY SWITCH TIMES:	
P1 MAX ON TIME	D (or change if desired)
P2 MAX ON TIME	D (or change if desired)
P2 MIN ON TIME	D (or change if desired)
P3 MIN ON TIME	D (not applicable)
Finish the WIZARD	
ENTER TIME, DATE AND MAINTENANCE INFORMATION AS PROMPTED	

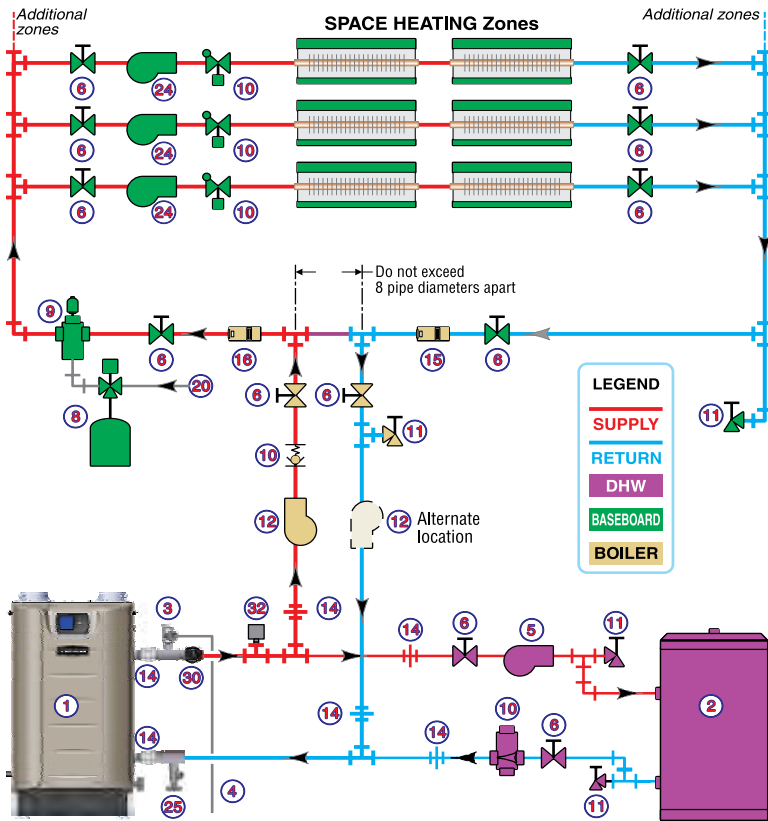
**Note 1:** If DHW is not used, provide a third space heating zone by setting up INPUT/OUTPUT 1 exactly the same as INPUT/OUTPUT 2. Make sure to assign INPUT/OUTPUT 1 to PRIORITY 2. This is because PRIORITY 2 is factory preset for space heating configurations. Wire the third zone thermostat to P11-4&5 and its circulator to P9-1,4&5.



# EXPRESS SETUP — EXAMPLE B *(continued)*

2- or 3-Zone SPACE HEATING (Circulators without circulator relays) | DHW (Direct-piped)

## PIPING

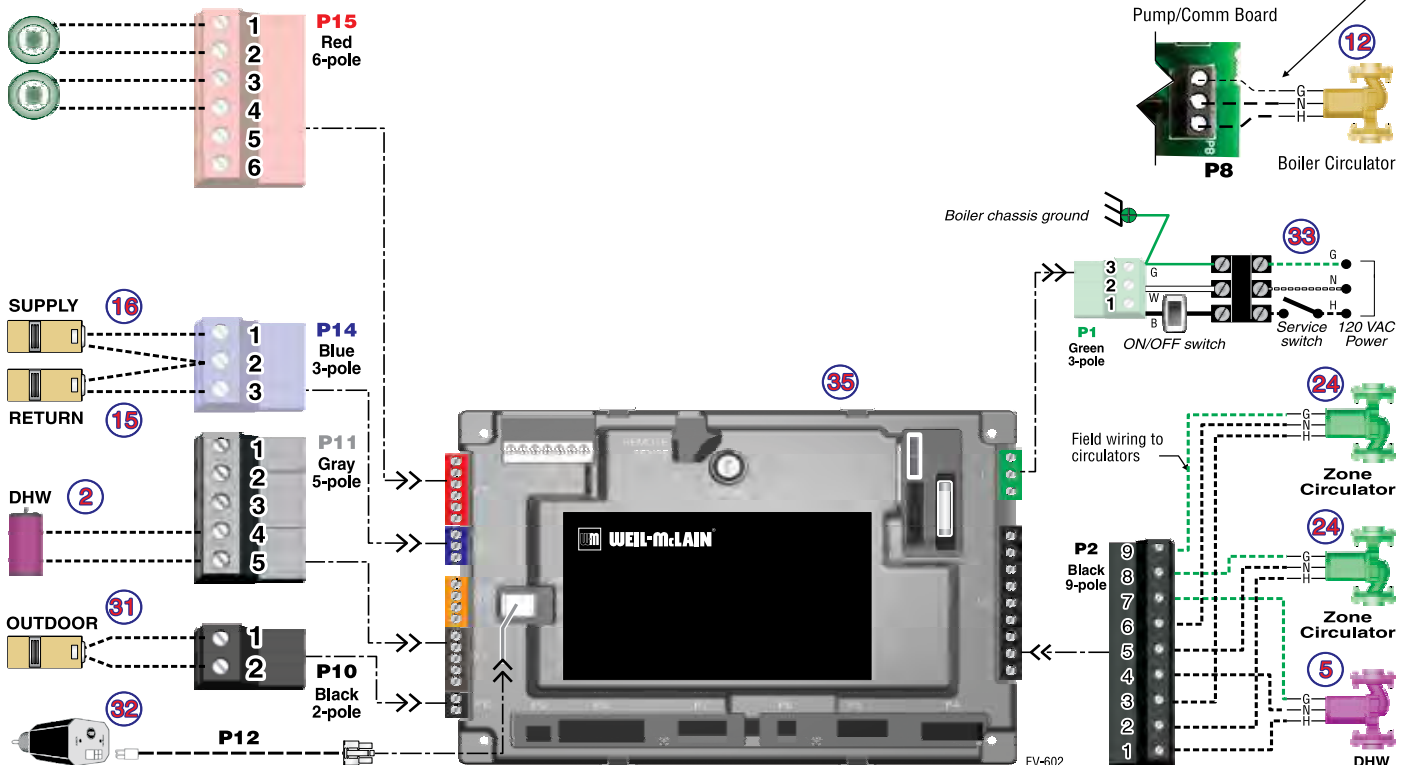


## LEGEND

- |  |   |
|--|---|
| 1 ■ Evergreen boiler.  | 14 Unions as needed for service.                                    |
| 2 Indirect water heater, if used (domestic water piping not shown) — MUST be direct piped to boiler to use default control settings.     | 15 Return temperature sensor.                                       |
| 3 ■ Relief valve, supplied with boiler, field piped — MUST be piped to boiler supply connection — see Figure 6, page 11 for information. | 16 Supply temperature sensor.                                       |
| 4 Relief valve piping to drain.  | 20 Make-up water supply.  |
| 5 DHW circulator.  | 24 Zone circulators.  |
| 6 Isolation valves.  | 25 ■ Boiler drain valve, supplied with boiler, field piped.         |
| 8 Expansion tank.  | 30 ■ Pressure/temperature gauge, supplied with boiler, field piped. |
| 9 Air separator.   | 31 Outdoor sensor.  |
| 10 Flow/check or spring check valves.  | 32 Low water cut-off.   |
| 11 Purge/drain valves.   | 33 120VAC power to boiler — see page 53.                            |
| 12 ■ Boiler circulator, supplied with boiler, field piped.   | 35 EVG Control module.  |
- = Items supplied with boiler — all other items supplied by installer.

## FIELD WIRING

### ZONE THERMOSTATS





# EXPRESS SETUP — EXAMPLE C

Multi-zone SPACE HEATING (Zone valves + WMZV controller) | DHW (Direct-piped)

**⚠ WARNING**

**Boiler Model, Altitude and Fuel Type are critical settings.** Failure to set correctly could result in severe personal injury, death or substantial property damage.

Incorrect setup or piping can result in severe personal injury, death or substantial property damage.

Use primary/secondary piping or equivalent ONLY. **Do not use direct-connect system piping.**

Verify that the correct system type is selected on the control and that operating temperature settings are suitable for the system. System and structural damage can occur if temperatures are too high.

## Purpose

- Space heating with multiple zones.
- Zoning with zone valves. **DO NOT** use 3-wire zone valves — the voltage on the valve end switch will damage the EVG control. Use only 4-wire zone valves with isolated end switches.
- DHW piped directly to the boiler.
- DHW priority — space heating is disabled during call for heat from water heater.

## Control setting notes

- See the table at right for required and optional settings.
- The sequence in the table follows the WIZARD.
- If not using the WIZARD, follow instructions elsewhere in this manual to enter the settings manually.
- The system circulator is wired to OUTPUT 2. It will be activated on any call for heat from a zone valve end switch.

## Circulators and piping

**⚠ WARNING**

Provide an external relay and external power to any circulator if its load rating exceeds 2.2 amps FLA, 3.6 amps locked rotor, or 16.4 amps in rush.

- Piping must be primary/secondary as shown.
- DHW circulator must be selected to handle the pressure drop through the boiler, water heater and piping. DHW circulator supplied by installer.
- For some large indirect water heaters, the required flow rate may require piping the water heater differently.
- The control settings in table at right provide DHW priority — space heating will be discontinued during a call for DHW.
- Zone valves and system circulator supplied by installer. For alternate zone wiring using a zone controller, see page 61.
- A by-pass pressure regulator is recommended when used in a zone valve system as shown in this express setup.

## BOILER

- Boiler circulator shipped loose with boiler.
- Follow all instructions in this manual for piping boiler and system.

### EVG CONTROL SETTINGS

(IN ORDER OF WIZARD SEQUENCES)

**RED** — VALUE MUST BE SET OR VERIFIED  
**D** — DEFAULT ACCEPTABLE; CHANGE ONLY IF DESIRED

BOILER SETTINGS	
BOILER MODEL	Verify model number is correct
WWS D TEMP	Default (70 °F) or as required
HIGH ALTITUDE	Set to altitude if over 2,000 feet
INPUT/OUTPUT 1 (Assign to PRIORITY 1)	
WHAT IS THE USE OF INPUT/OUTPUT 1?	HEAT/DHW DEMAND
WHAT PRIORITY IS INPUT #1?	select PRIORITY 1
WHAT SYSTEM TYPE IS INPUT/OUTPUT 1?	DHW (D)
TARGET MOD SENSOR	BOILER OUT (D)
TARGET ADJUST	NONE (D)
SUPPLY MAX	D (or change if desired)
RUN BOILER PUMP?	NO (D)
RUN AUX PUMP/OUTPUT?	D (not applicable)
INPUT/OUTPUT 2 (Assign to PRIORITY 2)	
WHAT IS THE USE OF INPUT/OUTPUT 2?	HEAT/DHW DEMAND
WHAT PRIORITY IS INPUT #2?	PRIORITY 2
WHAT SYSTEM TYPE IS INPUT/OUTPUT 2?	Select correct system type
TARGET MOD SENSOR	SYSTEM SUPPLY (D)
TARGET ADJUST	ODT (D) (outdoor sensor must be installed)
SUPPLY MAX	D (or change if desired)
SUPPLY MIN	D (or change if desired)
OD RESET MAX	D (or change if desired)
OD RESET MIN	D (or change if desired)
BOOST TIME	D (or change if desired)
RUN BOILER PUMP?	YES (D)
RUN AUX PUMP/OUTPUT?	D (not applicable)
INPUT/OUTPUT 3 (Not used)	
WHAT IS THE USE OF INPUT/OUTPUT 3?	NONE
PRIORITY SWITCH TIMES:	
P1 MAX ON TIME	D (or change if desired)
P2 MAX ON TIME	D (or change if desired)
P2 MIN ON TIME	D (or change if desired)
P3 MIN ON TIME	D (not applicable)
Finish the WIZARD	
ENTER TIME, DATE AND MAINTENANCE INFORMATION AS PROMPTED	

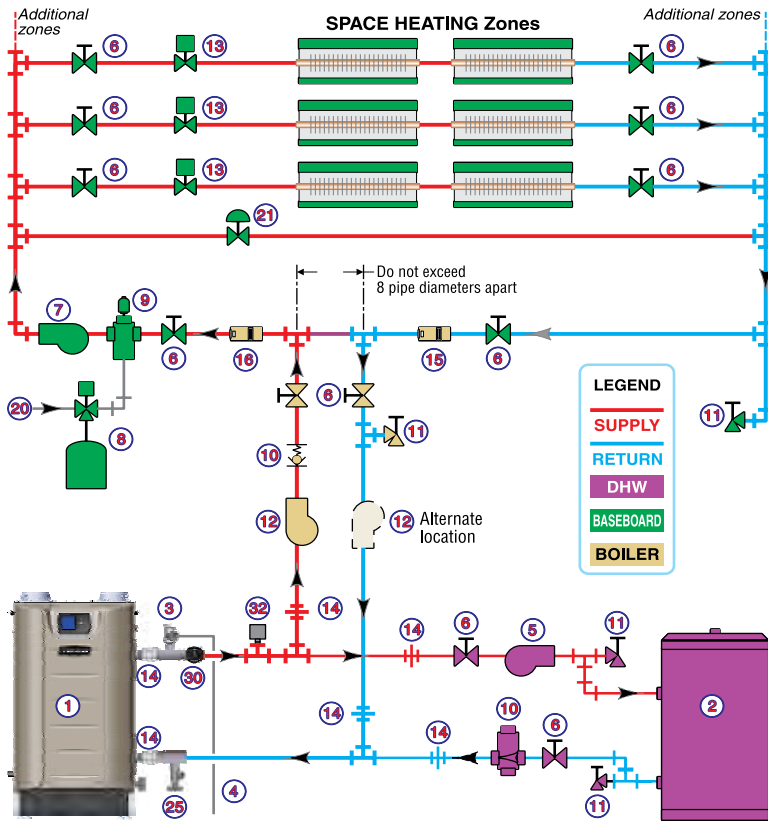
**Note 1:** If DHW is not used, set the USE of INPUT/OUTPUT 1 to NONE. Keep all other wiring as shown at right and follow all settings given above for PRIORITY 2.



# EXPRESS SETUP — EXAMPLE C *(continued)*

Multi-zone SPACE HEATING (Zone valves + WMZV controller) | DHW (Direct-piped)

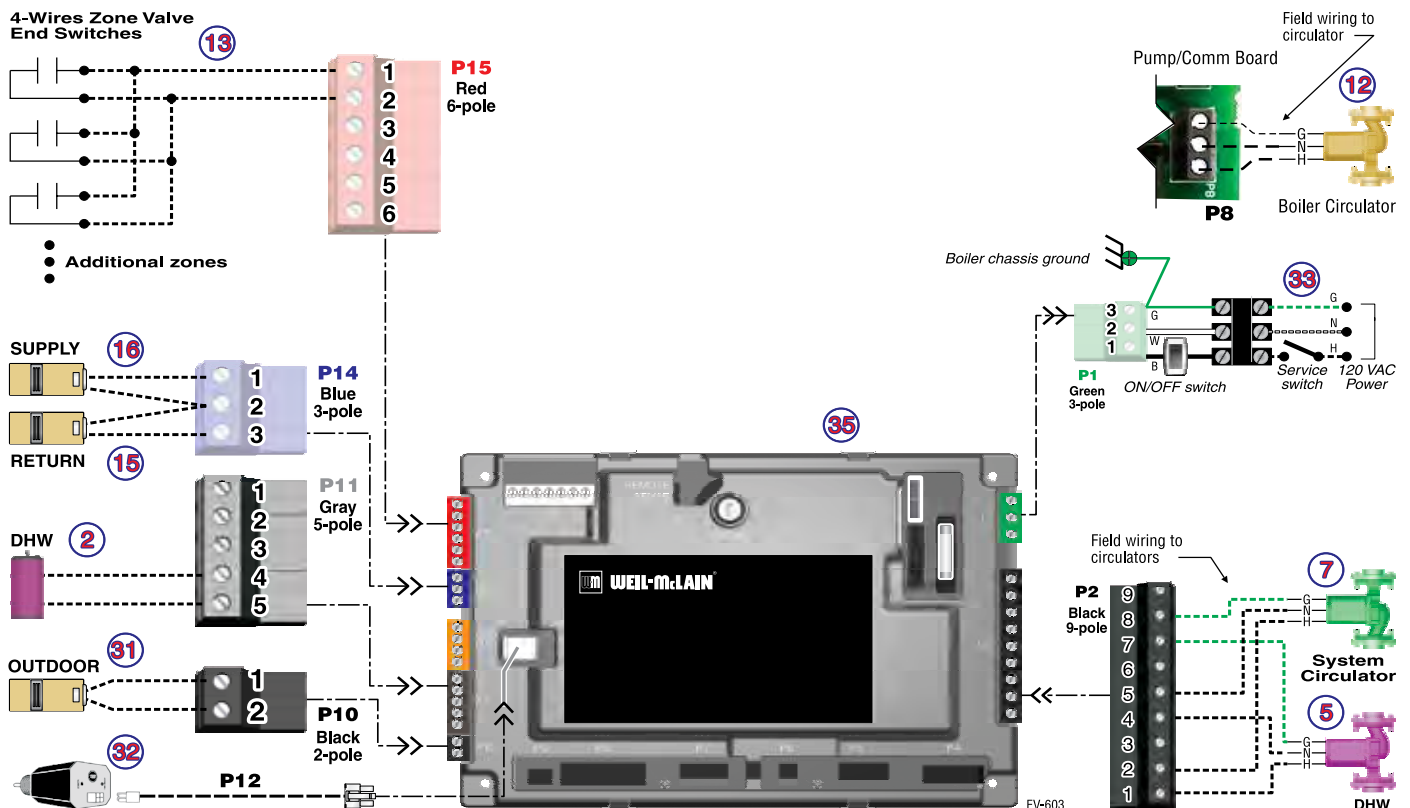
## PIPING



## LEGEND

- |   |  |
|---|--|
| 1 ■ Evergreen boiler.   | 13 Zone valves.  |
| 2 Indirect water heater, if used (domestic water piping not shown) — <b>MUST be direct piped to boiler to use default control settings.</b>     | 14 Unions as needed for service.                                       |
| 3 ■ Relief valve, supplied with boiler, field piped — <b>MUST be piped to boiler supply connection</b> — see Figure 6, page 11 for information. | 15 Return temperature sensor.  |
| 4 Relief valve piping to drain.   | 16 Supply temperature sensor.  |
| 5 DHW circulator.   | 20 Make-up water supply.   |
| 6 Isolation valves.   | 21 By-pass pressure regulator, <b>REQUIRED</b> for zone valve systems. |
| 7 System circulator.  | 25 ■ Boiler drain valve, supplied with boiler, field piped.            |
| 8 Expansion tank.   | 30 ■ Pressure/temperature gauge, supplied with boiler, field piped.    |
| 9 Air separator.  | 31 Outdoor sensor.   |
| 10 Flow/check or spring check valves.   | 32 Low water cut-off.  |
| 11 Purge/drain valves.  | 33 120VAC power to boiler — see page 53.                               |
| 12 ■ Boiler circulator, supplied with boiler, field piped.  | 35 EVG Control module.   |
- = Items supplied with boiler — all other items supplied by installer.

## FIELD WIRING





# Available control settings and system presets

**Figure 72** Evergreen control settings available in BASIC MODE (see Advanced Manual for ADVANCED MODE settings)

Available settings from CONTRACTOR MENU		
Boiler Settings Menu	Priority 2 menu	Assign Inputs menu
• Boiler Model	• Inputs Assigned (non-selectable)	<b>Input 1: TT1</b>
• Control Type	• System Type	• Priority 1, 2 or 3
• High Altitude	• Target Mod Sensor (non-selectable)	• Source (TT1 or 0-10v)
• LP Gas	• Target Adjust (non-selectable)	• AUX PUMP/OUTPUT
• ODT Sensor Exempt	• Supply Max	• Off
• Manual Reset High Limit Temp	• Supply Min (not available for DHW) *	
• WWSD Temp	• OD Reset Max (or Volts for Max) *	<b>Input 2: TT2 and Input 3:TT3</b>
• Adjust Outdoor	• OD Reset Min (or Volts for Min) *	• Priority 1, 2 or 3
• Circulator Exercising	• Boost Time *	• AUX PUMP/OUTPUT
• Freeze Protect Circs		• Off
• Reset Factory Default	<b>Priority 3 menu</b>	
	• Inputs Assigned (non-selectable)	<b>Diagnostics menu</b>
	• System Type	• See <a href="#">Figure 80, page 80</a> for details.
<b>Priority 1 menu</b>	• Target Mod Sensor (non-selectable)	
• Inputs Assigned (non-selectable)	• Target Adjust (non-selectable)	<b>Maintenance Info menu</b>
• System Type	• Supply Max	• See <a href="#">Figure 85, page 85</a> for details.
• Target Mod Sensor (non-selectable)	• Supply Min (not available for DHW) *	
• Target Adjust (non-selectable)	• OD Reset Max (or Volts for Max) *	<b>Set Date and Time menu</b>
• Supply Max	• OD Reset Min (or Volts for Min) *	• See <a href="#">Figure 85, page 85</a> for details.
• Supply Min (not available for DHW) *	• Boost Time *	
• OD Reset Max (or Volts for Max) *		
• OD Reset Min (or Volts for Min) *		* These items only appear in the menus if Target Adjust is active.
• Boost Time *		

**Figure 73** System types available in BASIC MODE (each option shown with factory settings)

System Type	8-Character Abbreviation	3-Character Abbreviation	Supply Max °F	OD Reset Min °F	Supply Min °F	OD Reset Max °F	Run Boiler Pump	Run AUX PUMP/OUTPUT
Fan-coil	FAN-COIL	FCL	180	0	140	70	YES	YES
Finned Tube Baseboard	FIN BASE	FTB	180	0	130	70	YES	YES
Cast Iron Baseboard	IRONBASE	CIB	180	0	120	70	YES	YES
Cast Iron Radiators	RADIATOR	CIR	180	0	120	70	YES	YES
Radiant - slab on grade	RAD SLAB	RSG	120	0	80	70	YES	YES
Radiant - thin slab	RAD SLAB	RTS	140	0	80	70	YES	YES
Radiant - below floor (staple up)	RADFLOOR	RSU	160	0	90	70	YES	YES
Radiant - above floor (sleeper system)	RADFLOOR	RAF	140	0	90	70	YES	YES
Domestic Hot Water	DOMESTIC	DHW	180	N/A	N/A	N/A	NO	NO
Custom (user defined)	XXXXXXXX (user input)	first three of user input	180	0	70	70	YES	YES

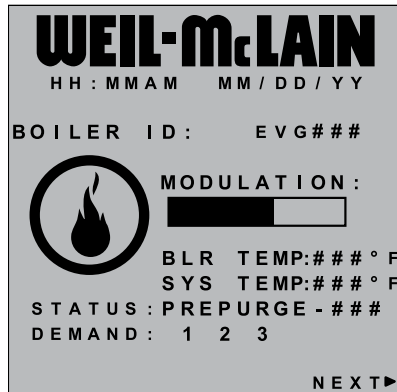


# CONTRACTOR menus

**⚠ WARNING** Boiler Model, Altitude and Fuel Type are critical settings. Failure to set correctly could result in severe personal injury, death or substantial property damage.

1. Access contractor menus by pressing and holding the UP and DOWN arrow keys at the same time for 7 seconds.
2. See the following pages for explanations of control setting options.

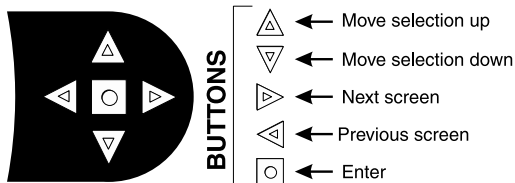
Figure 74 Evergreen control menu access — accessing contractor menus



**▲ + ▼ Hold 7 secs**



Highlight item, then press **◻** to select



**CONTROL NAVIGATION BUTTONS**

EV-002a

MENU ITEM	PURPOSE	More information
USER MODE	<ul style="list-style-type: none"> <li>The default for this setting is <b>BASIC</b> mode. Screens shown in this manual assume the USER MODE is set to BASIC. For advanced features available in <b>ADVANCED</b> mode, see the Evergreen Advanced Manual.</li> </ul>	
BOILER SETTINGS	<ul style="list-style-type: none"> <li>Set/change boiler model, control type, high altitude setting, ODT sensor requirement, manual reset, high limit and WWSD temperature settings, outdoor sensor temp adjustment, circulator exercising, freeze protection setup, and restore to factory default option.</li> </ul>	See <a href="#">page 76</a>
PRIORITY 1	<ul style="list-style-type: none"> <li>These settings control operating temperatures and behaviors for systems that are assigned to “PRIORITY 1.”</li> </ul>	See <a href="#">page 77</a>
PRIORITY 2	<ul style="list-style-type: none"> <li>These settings control operating temperatures and behaviors for systems that are assigned to “PRIORITY 2.”</li> </ul>	See <a href="#">page 77</a>
PRIORITY 3	<ul style="list-style-type: none"> <li>These settings control operating temperatures and behaviors for systems that are assigned to “PRIORITY 3.”</li> </ul>	See <a href="#">page 77</a>
ASSIGN INPUTS	<ul style="list-style-type: none"> <li>These settings assign Priority 1, 2 or 3 to each of the three inputs to the Evergreen control.</li> </ul>	See <a href="#">page 78</a>
DIAGNOSTICS	<ul style="list-style-type: none"> <li>Use to review current and historical information including previous lockouts.</li> </ul>	See <a href="#">page 80</a>
MAINTENANCE INFO	<ul style="list-style-type: none"> <li>Used to set contractor contact information, boiler information and maintenance dates.</li> </ul>	See <a href="#">page 85</a>
SET TIME & DATE	<ul style="list-style-type: none"> <li>Use to set date and time — important since fault occurrences are date/time stamped.</li> </ul>	None

Screens shown above are typical only. Actual screens depend on control settings chosen.

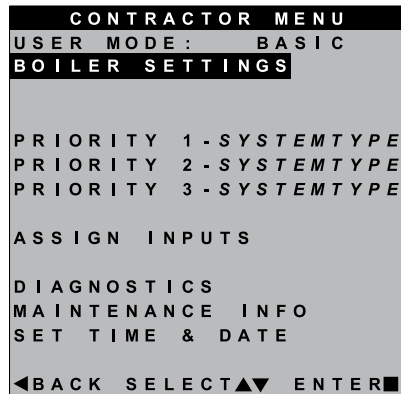


# BOILER SETTINGS menu, BASIC mode

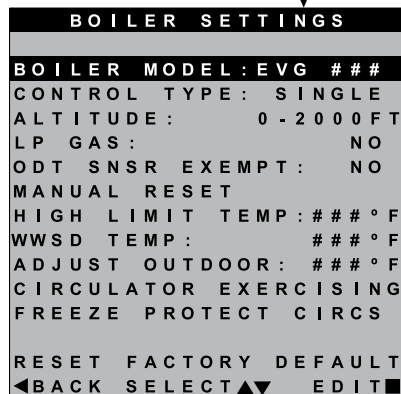
**⚠ WARNING** Boiler Model, Altitude and Fuel Type are critical settings. Failure to set correctly could result in severe personal injury, death or substantial property damage.

1. Access contractor menus by pressing and holding the UP and DOWN arrow keys at the same time for 7 seconds.
2. See Figure 74, page 75 for the screen sequences up to the CONTRACTOR menu.

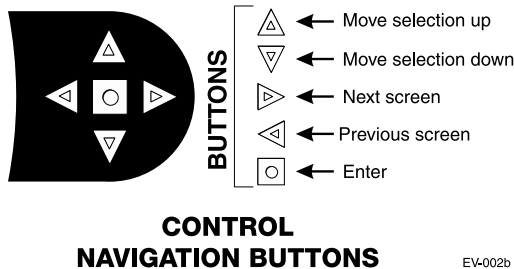
**Figure 75** Evergreen BASIC mode BOILER SETTINGS options (USER MODE must be set to BASIC)



Highlight BOILER SETTINGS then press



Highlight item, then press to select



EV-002b

MENU ITEM	DESCRIPTION
<b>BOILER MODEL</b>	<ul style="list-style-type: none"> <li>• <b>⚠ WARNING</b> MUST be set to correct model.</li> <li>• Check the boiler model against the model listed on the boiler's rating plate. Change the selection to the correct model if not. Also verify the model number on the Evergreen control display at power-up. Failure to correct would result in severe personal injury, death or substantial property damage.</li> </ul>
<b>CONTROL TYPE</b>	<ul style="list-style-type: none"> <li>• Select single, master or shadow. Must be set to Single for basic mode.</li> </ul>
<b>HIGH ALTITUDE</b>	<ul style="list-style-type: none"> <li>• <b>⚠ WARNING</b> MUST be set to correct value if altitude over 2,000 feet — values selectable in 500 feet increments.</li> </ul>
<b>LP GAS</b>	<ul style="list-style-type: none"> <li>• <b>⚠ WARNING</b> MUST be correct — YES if LP Gas is used or NO if natural gas is used. Follow screen instructions to change if necessary.</li> </ul>
<b>ODT SENSOR EXEMPT</b>	<ul style="list-style-type: none"> <li>• Select YES only if boiler is exempt from the requirement for outdoor reset operation stipulated in Section 303 of the 2007 Energy Act. See information provided elsewhere in this manual.</li> </ul>
<b>MANUAL RESET HIGH LIMIT TEMP</b>	<ul style="list-style-type: none"> <li>• If boiler outlet water temperature exceeds this temperature, the Evergreen control will shut down the boiler and enter lockout. Changing this setting is NOT recommended.</li> </ul>
<b>WWSD TEMP</b>	<ul style="list-style-type: none"> <li>• WWSD stands for warm weather shut down. It means the boiler will not be allowed to fire if the outside temperature is greater than the WWSD setting. When the boiler is kept off because the outside temperature is above WWSD, the graphic display will show WWSD, and the boiler will remain in standby until the outside temperature drops below WWSD temperature. WWSD does not apply to DHW systems. The outdoor sensor must be installed to use this function.</li> </ul>
<b>ADJUST OUTDOOR</b>	<ul style="list-style-type: none"> <li>• Use this setting to calibrate the outdoor sensor when needed to compensate for variations in lead length or other factors that could affect total resistance in sensor circuit.</li> </ul>
<b>CIRCULATOR EXERCISING</b>	<ul style="list-style-type: none"> <li>• For each circulator, select whether you want the control to automatically start the circulator and run for 10 seconds for each 72-hour period of inactivity.</li> </ul>
<b>FREEZE PROTECT CIRCS</b>	<ul style="list-style-type: none"> <li>• This function automatically fires the boiler at low fire and starts the circulators chosen if the heat exchanger sensors detect a temperature less than 45 °F. Burner is turned on if temperature drops below 40 °F. Circulators and burner turn off when the temperature rises above 48 °F.</li> </ul>
<b>RESET FACTORY DEFAULTS</b>	<ul style="list-style-type: none"> <li>• Use this function to restore all control settings to factory default values — will require complete restart and setup of control after resetting. Record information from the MAINTENANCE screen and any history information that may be of use in the future. ALL stored data is eliminated when reset to defaults except for boiler model number.</li> </ul>

Screens shown above are typical only. Actual screens depend on control settings chosen.

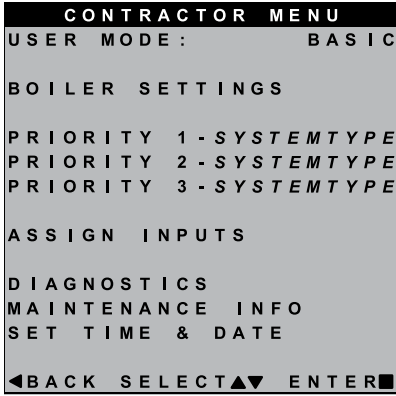


# PRIORITY 1, 2, 3 menus, BASIC mode

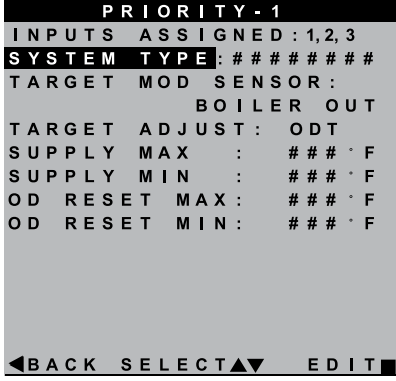
**WARNING** Boiler Model, Altitude and Fuel Type are critical settings. Failure to set correctly could result in severe personal injury, death or substantial property damage.

1. Access contractor menus by pressing and holding the UP and DOWN arrow keys at the same time for 7 seconds.
2. See Figure 74, page 75 for the screen sequences up to the CONTRACTOR menu.

Figure 76 Evergreen BASIC mode PRIORITY options (USER MODE must be set to BASIC)

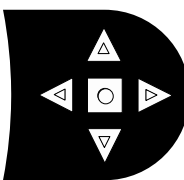


**Highlight PRIORITY 1, 2 or 3 then press**



**Highlight item, then press to select**

MENU ITEM	DESCRIPTION
INPUTS ASSIGNED	<ul style="list-style-type: none"> <li>Lists all the inputs already assigned to this PRIORITY. Inputs will be listed as 1, 2, 3.</li> <li>Shows NONE if there are no inputs assigned to this priority.</li> </ul>
SYSTEM TYPE	<ul style="list-style-type: none"> <li>Select the system type for this PRIORITY, based on the heating terminal units in the system (see Figure 73, page 74). Use the CUSTOM selection to set the control for a different system type. The factory preset values for SUPPLY MAX, SUPPLY MIN, OD RESET MAX and OD RESET MIN are chosen based on the normal best setting for the terminal units.</li> </ul>
TARGET MOD SENSOR	<ul style="list-style-type: none"> <li>Choose SYSTEM SUPPLY or BOILER OUT to determine which will be the primary temperature sensor. The control will modulate boiler input to reach the TARGET temperature. (Default is System Supply.) If system sensors are not used, boiler defaults to using heat exchanger outlet sensor in place of system sensor.</li> <li>Not adjustable in Basic Mode, see Advanced Manual for information on adjusting this parameter.</li> </ul>
TARGET ADJUST	<ul style="list-style-type: none"> <li>Select how target temperature is calculated by control: NONE (no reset, fixed target temperature), 0-10V (target temperature based on analog input from remote source), ODT (outdoor reset operation; default setting).</li> <li>Not adjustable in Basic Mode, see Advanced Manual for information on adjusting this parameter.</li> </ul>
SUPPLY MAX	<ul style="list-style-type: none"> <li>Set SUPPLY MAX to the required supply water temperature for the system at design maximum heat loss (typically 180 °F for finned tube baseboard on new installations.)</li> </ul>
SUPPLY MIN	<ul style="list-style-type: none"> <li>SUPPLY MIN should equal the desired minimum supply water temperature for the system.</li> <li>This line is not shown on priorities configured as DHW system type or Heating system type, if outdoor temperature sensor not used. See Advanced Manual for information on adjusting this parameter.</li> </ul>
OD RESET MAX (Not shown for Priority 1 by default)	<ul style="list-style-type: none"> <li>OD RESET MAX is the outdoor temperature at which the target temperature reaches its minimum (SUPPLY MIN).</li> <li>This line is not shown on priorities configured as DHW system type or Heating system type, if outdoor temperature sensor not used. See Advanced Manual for information on adjusting this parameter.</li> </ul>
OD RESET MIN	<ul style="list-style-type: none"> <li>OD RESET MIN means the outdoor temperature at which the target temperature reaches its maximum value (SUPPLY MAX).</li> <li>OD RESET MIN should equal the ODT (outdoor design temperature) for the installation's location.</li> <li>This line is not shown on priorities configured as DHW system type or Heating system type, if outdoor temperature sensor not used. See Advanced Manual for information on adjusting this parameter.</li> </ul>



**CONTROL NAVIGATION BUTTONS**

- ▲ Move selection up
- ▼ Move selection down
- ▶ Next screen
- ◀ Previous screen
- Enter

Screens shown above are typical only. Actual screens depend on control settings chosen.

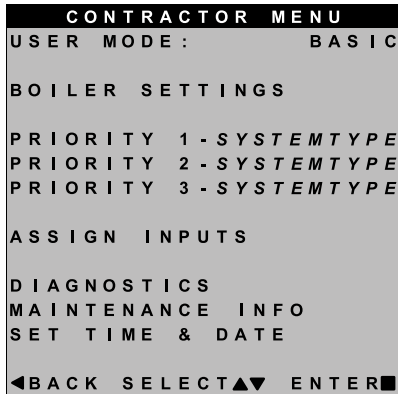


# ASSIGN INPUTS menu, BASIC mode

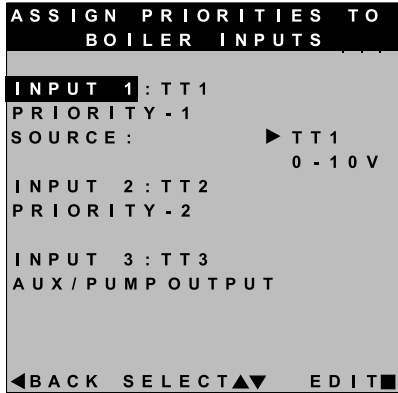
**⚠ WARNING** Boiler Model, Altitude and Fuel Type are critical settings. Failure to set correctly could result in severe personal injury, death or substantial property damage.

1. Access contractor menus by pressing and holding the UP and DOWN arrow keys at the same time for 7 seconds.
2. See [Figure 74, page 75](#) for the screen sequences up to the CONTRACTOR menu.

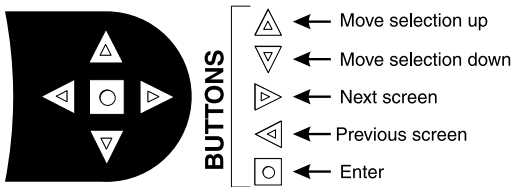
**Figure 77** Evergreen BASIC mode ASSIGN INPUT options (USER MODE must be set to BASIC) — see [Figure 78, page 79](#) and [Figure 79, page 79](#) for explanation of AUX PUMP/OUTPUT settings



Highlight **ASSIGN INPUTS** then press



Highlight item, then press to select



**CONTROL NAVIGATION BUTTONS**

EV-002db

MENU ITEM	DESCRIPTION
Overview	<ul style="list-style-type: none"> <li>• There are three priority levels defined by the settings chosen in <a href="#">Figure 76, page 77</a>.</li> <li>• For DHW priority, make sure PRIORITY 1 is defined for a DHW system.</li> <li>• If DHW priority is required and analog input (0-10v remote modulation) is used for space heating, wire the DHW aquastat to Input 2 (TT2) and assign INPUT 2 as PRIORITY 1 and INPUT 1 as PRIORITY 2 with SOURCE set to 0-10V.</li> </ul>
INPUT 1	<ul style="list-style-type: none"> <li>• Assign priority (system type) for INPUT 1 — options are:</li> <li>• PRIORITY 1 — assigns INPUT 1 to PRIORITY 1 system.</li> <li>• PRIORITY 2 — assigns INPUT 1 to PRIORITY 2 system</li> <li>• PRIORITY 3 — assigns INPUT 1 to PRIORITY 3 system</li> <li>• AUX PUMP/OUTPUT</li> <li>• OFF</li> <li>• NOTE: For INPUT 1 only, select SOURCE = TT1 for thermostat input or 0-10V if analog input is required.</li> </ul>
INPUT 2	<ul style="list-style-type: none"> <li>• Assign priority (system type) for INPUT 2 — options are:</li> <li>• PRIORITY 1 — assigns INPUT 2 to PRIORITY 1 system.</li> <li>• PRIORITY 2 — assigns INPUT 2 to PRIORITY 2 system</li> <li>• PRIORITY 3 — assigns INPUT 2 to PRIORITY 3 system</li> <li>• AUX PUMP/OUTPUT</li> <li>• OFF</li> </ul>
INPUT 3	<ul style="list-style-type: none"> <li>• Assign priority (system type) for INPUT 3 — options are:</li> <li>• PRIORITY 1 — assigns INPUT 3 to PRIORITY 1 system.</li> <li>• PRIORITY 2 — assigns INPUT 3 to PRIORITY 2 system</li> <li>• PRIORITY 3 — assigns INPUT 3 to PRIORITY 3 system</li> <li>• AUX PUMP/OUTPUT</li> <li>• OFF</li> </ul>

Screens shown above are typical only. Actual screens depend on control settings chosen.



# ASSIGN INPUTS menu, BASIC mode *(continued)*

**Figure 78** AUX PUMP/OUTPUT operation (accessed in ASSIGN INPUTS menu – see [Figure 77, page 78](#))

Option	Activation conditions	Suggested uses
<b>ALWAYS ON</b>	<ul style="list-style-type: none"> <li>Output is always energized whenever the control is powered.</li> </ul>	<ul style="list-style-type: none"> <li>Hot loop for seasonal boilers that are manually shut down at end of season and started up at start of heating season.</li> </ul>
<b>EXTERNAL SWITCH</b>	<ul style="list-style-type: none"> <li>The output is energized on closure of an external switch wired to this input and is de-energized when the external switch opens.</li> </ul>	<ul style="list-style-type: none"> <li>Hot loop for boilers whose CH is manually shut down at end of season and started up at start of heating season, but remain available for local calls (DHW, etc.).</li> </ul>
<b>OUTDOOR BELOW WWSD</b>	<ul style="list-style-type: none"> <li>This output is energized only when outdoor temperature is below the WWSD setting (see BOILER SETTINGS menu, <a href="#">Figure 75, page 76</a>).</li> <li>This setting is non-selectable if WWSD is set to OFF or ODT is not connected at initial boiler power. If Outdoor Below WWSD is already chosen and WWSD is later set to OFF, Outdoor Below WWSD will behave as Always On.</li> </ul>	<ul style="list-style-type: none"> <li>Hot loop for boilers whose CH is automatically shut down based on outdoor temperature (inferred heat loss), but remain on for local calls (DHW, etc.).</li> </ul>
<b>ANY TT INPUT</b>	<ul style="list-style-type: none"> <li>The assigned output is energized if there is an input closure on this boiler.</li> <li>The assigned output will de-energize once there are; no input on this boiler, post-purge has finished and post-pump time has expired.</li> <li>If the closed input is configured for a heat demand, its output will de-energize after post-purge and post-pump.</li> </ul>	<ul style="list-style-type: none"> <li>Energize a system pump relay if pump must run during all heating calls.</li> </ul>
<b>ANY TT INPUT BY ITS PRIORITY SETTINGS</b>	<ul style="list-style-type: none"> <li>The assigned output is energized:                             <ul style="list-style-type: none"> <li>If there is an input closure on this boiler.</li> <li>... <b>and</b> ...</li> <li>RUN AUX PUMP/OUTPUT is set to YES for the priority assigned to the closed input.</li> </ul> </li> <li>The assigned output will de-energize once there are no input closures on any of the network boilers, post-purge has finished, and post-pump time has expired.</li> </ul>	<ul style="list-style-type: none"> <li>Energize a system pump relay if pump must run only on some heat calls (such as systems with locally-connected DHW heating).</li> </ul>
<b>BURNER DEMAND</b>	<ul style="list-style-type: none"> <li>The assigned output is energized when the boiler receives a call for heat and starts to pre-purge.</li> <li>The assigned output is de-energized once the burner is off and post-purge is complete.</li> </ul>	<ul style="list-style-type: none"> <li>Use for interlocking with combustion air damper, flow switch, etc.</li> </ul>

**Figure 79** AUX PUMP/OUTPUT operation — start, run and stop, based on boiler status

Option	Standby	TT Closed	Pre-Pump	Pre-Purge	Burner Running	Post-Purge	Post-Pump	Standby	Comments
<b>ANY TT INPUT OR ANY TT INPUT BY ITS PRIORITY SETTINGS</b>	off	ON	→					off	<ul style="list-style-type: none"> <li>See Figure 78 for explanation of differences between the ANY TT INPUT options.</li> </ul>
<b>BURNER DEMAND</b>	off	off	off	ON	→		off	off	



# DIAGNOSTIC menu

Figure 80 DIAGNOSTICS menu navigation (see Figure 71, page 67 for access information)

Menus	Next screen	Next screen	Next screen	Next screen
<i>Follow information at the bottom of each screen to navigate to next/previous screen or enter/save data</i>				
DIAGNOSTICS	TEMPERATURES	STATUS: ##### BOILER OUT1: ### °F BOILER OUT2: ### °F BOILER IN: ### °F SYSTEM SUPPLY: ### °F SYSTEM RETURN: ### °F FROM SENSOR: ##### FLUE 1: ### °F FLUE 2: ### °F OUTDOOR TEMP: ### °F FROM SENSOR: #####	See following pages for details.	
	INPUTS	STATUS: ##### INPUT1: ##### (8-character system type) INPUT2: ##### (8-character system type) INPUT3: ##### (8-character system type) 0–10v: #.#V LINKED TO MASTER: ### DEMAND OF MASTER: ### MANUAL LIMIT: ##### AUTO LIMIT: ##### LOW WTR CUTOFF: ##### AIR P-SWITCH: ##### CLOSURE SWITCH: ##### BLOWER SPEED: ####RPM FLAME SIGNAL: ###	See following pages for details.	
	OUTPUTS	STATUS: ##### GAS VALVE: ### CIRC OUTPUT 1: ### CIRC OUTPUT 2: ### CIRC OUTPUT 3: ### BOILER CIRC: ### BLOWER SIGNAL: ###% ADD'L HEAT DEMANDS: ### ALARM: ###	See following pages for details.	
	RUNTIME	BURNER TIME: ###HR ROTATE TIME: ##DAYS INPUT1 TIME: ###HR INPUT2 TIME: ###HR INPUT3 TIME: ###HR NETWORK TIME: ###HR IGNITION COUNT: ###	See following pages for details.	
	MASTER-SHADOW COMM (shows on shadow boilers only)	Boiler ID: ##### Linked to Master: ### Boilers on Network: # Requested to Run: ### Type: #####-## Requested Mod Rate: ### Max Boiler Temp: ### °F Boiler ON Diff: ## °F Boiler OFF Diff: ## °F	See following pages for details.	
	NETWORK BOILERS (shows on master boilers only)	Shows firing rate, boiler temperature, active priority, with system type and sequence order of all boilers on the network.	See following pages for details.	



# DIAGNOSTICS menu *(continued)*

Figure 81 DIAGNOSTICS menu navigation, continued (see Figure 71, page 67 for access information)

Menus	Next screen	Next screen	Next screen	Next screen
<b>Follow information at the bottom of each screen to navigate to next/previous screen or enter/save data</b>				
DIAGNOSTICS <i>(cont.)</i>	NETWORK INPUTS (shows on master boilers only)	Shows input status of all network boiler inputs.		
	SOFTWARE VERSIONS	DISPLAY WM#.# MAIN MICRO WM#.# SECOND MICRO WM#.#	See following pages for details.	
	PAST ERRORS	CONTROL FAULTS: ### IGNITION RETRIES: ###	See following pages for details.	
		MANUAL RESET CNT: ###	See following pages for details.	
		AUTO RESET CNT: ###	See following pages for details.	
		LOCKOUT HISTORY 1 LOCKOUT HISTORY 2 LOCKOUT HISTORY 3	LOCKOUT HISTORY # FAULT NAME: #### FAULT TYPE: #### TIME: HH:MM AM DATE: MM/DD/YY STATUS: ####### TEMPERATURES INPUTS OUTPUTS	TEMPERATURES INPUT STATUS OUTPUT STATUS
MANUAL TEST MODE (Single boiler or network Shadow boiler)	STATUS: ####### INPUTS: #### TARGET: ### °F or “%” for network MODULATION: ####### BOILER OUT: ### °F BOILER IN: ### °F SYSTEM SUPPLY: ### °F SYSTEM RETURN: ### °F FLUE: ### °F OUTDOOR: ### °F BLOWER SIGNAL: ###% BLOWER SPEED: ###RPM FLAME SIGNAL: ### FORCE RATE: AUTO	See following pages for details.		
MANUAL RESET	PRESS ENTER TO RESET THE FOLLOWING ERROR (SCREEN SHOWS A LIST OF ERRORS)	See following pages for details.		



# DIAGNOSTICS menu *(continued)*

**Figure 82** DIAGNOSTICS menu details (see [Figure 71](#), page 67 for access information)

Menu/Item	Comment
<b>Temperatures</b>	
Status	Current operating status of the boiler. Prepurge, Ignition, Name of the system Type being satisfied, post purge, Warm Weather Shut down, Trouble
Boiler Out1	Temperature of the first sensing element of the boiler's heat exchanger outlet sensor
Boiler Out2	Temperature of the second sensing element of the boiler's heat exchanger outlet sensor
Boiler In	Temperature of the boiler's heat exchanger inlet sensor
System Supply	Temperature of the system water after the boiler loop
System Return	Temperature of the system water returning to the boiler loop
From Sensor	Displays where System Supply/Return values are being read from. Most relevant when using multiple sensors connected to the same Master Boiler Network. When Shadow boilers are connected, this will specify which boiler it is reading.
Flue1	Temperature of the first sensing element of the boiler's flue gas sensor
Flue2	Temperature of the second sensing element of the boiler's flue gas sensor
Outdoor	Temperature of the remote outdoor air temperature sensor

<b>Inputs</b>	
Status	Current operating status of the boiler. Prepurge, Ignition, Name of the system Type being satisfied, post purge, Warm Weather Shut down, Trouble
Input 1	Call for heat status on Input 1 (Input 1 can be TT1 or 0-10VDC input)
Input 2	Call for heat status on Input 2
Input 3	Call for heat status on Input 3
0-10V	Voltage input for target adjust or modulation for single boiler
Linked to Master	For Multiple Boiler Networks. Shows if current control is connected to Master boiler
Demand of Master	For Multiple Boiler Networks. Shows if the Master boiler is calling this boiler heat demand
Manual Limit	External manual limit on low voltage terminal strip
Auto Limit	External auto limit on low voltage terminal strip
Low Wtr Cutoff	Low water cutoff device (inside boiler jacket)
Air P-Switch	Limit device (inside boiler jacket) that will shut off the boiler if flue pressure becomes too high
Closure Switch	P7 jumper circuit closed or open (flow switch, CAD, etc.)
Blower Speed	Feedback from blower sensor
Flame Signal	Number indicating the presence and quality of the flame used to shut down or boost the boiler

<b>Outputs</b>	
Status	Current operating status of the boiler. Prepurge, Ignition, Name of the system Type being satisfied, post purge, Warm Weather Shut down, Trouble
Gas Valve	Control's gas valve circuit status
Circulator 1	Control's circulator 1 relay status
Circulator 2	Control's circulator 2 relay status
Circulator 3	Control's circulator 3 relay status
Boiler Circ	Boiler's circulator
Blower Signal	Control's signal controlling the blower speed
Additional Heat Demand	Additional heat demand contact status
Alarm	Alarm contact status



# DIAGNOSTICS menu *(continued)*

Figure 83 DIAGNOSTICS menu details (continued) (see [Figure 71, page 67](#) for access information)

Menu/Item	Comment
<b>Run Times</b>	
Burner Time	Displays cumulative time the burner has been active (can be increased by user)
Rotate Time	Records the days of operation passed from the last time the Master boiler rotated the firing sequence.
Input 1 Time	Displays cumulative time that Input 1 has been closed (Or 0-10V ≥ 1 volt)
Input 2 Time	Displays cumulative time that Input 2 has been closed
Input 3 Time	Displays cumulative time that Input 3 has been closed
Network Time	Records time this boiler was running on a network call for heat generated by the Master boiler
Ignition Count	Displays total number of successful ignitions
<b>Master-Shadow Comm</b>	
Boiler ID	Displays boiler control type and ID number
Linked to Master	Shows if control is currently linked to a Master control
Boilers on Network	Shows number of boilers currently on network
Requested to Run	Shows if this control is being requested to satisfy a network call
Type	Shows whether the control is Network-P1, Network-P2, or NONE
Requested Mod Rate	Rate coming from the Master
Max Boiler Temp	Displays maximum allowable boiler temperature
Boiler On Diff	Temperature differential from master boiler for network priorities
Boiler Off Diff	Temperature differential from master boiler for network priorities
<b>Network Boilers</b> <b>For multiple boilers only – See EVG Advanced manual</b>	
###%	Shows current rate of boiler
###F	Shows Boiler Out temperature of boiler
#####	Shows priority being satisfied, updated based on active demand
#####	Shows system type of call for heat, updated based on active demand
# OF #	Shows the sequence position of that boiler in all the boilers available
BLR#	Shows boiler number this data belongs to
<b>Network Inputs</b>	
Boiler number	Displays boiler number
Inputs	Displays input's configuration and whether it is active. If input is active, it will be displayed in <b>BOLD</b> print
<b>Software Versions</b>	
Display	Software version of the microprocessor on the display circuit board
Main Micro	Software version of the main microprocessor on the control circuit board
Second Micro	Software version of the second microprocessor on the control circuit board
<b>TO RESET ALL HISTORY COUNTERS TO ZERO:</b>	To reset all history counters to zero: Enter the PAST ERRORS menu. Then press and hold the left and right arrows located below the control display. Hold for 5 seconds. This will cause ALL history to be deleted. To maintain history, reset counters individually.
<b>Past Errors</b>	
Control Fault	Displays number of control faults
Ignition Retries	Displays cumulative ignition attempts. It is recommended that his be reset during yearly maintenance by holding down the <b>Left</b> and <b>Right</b> arrows or by selecting this line and pressing the <b>Enter</b> button
Manual Reset Cnt	Displays number of manual reset lockouts since last cleared
Auto Reset Cnt	Displays number of auto reset lockouts since last cleared
Lockout History 1	Choose this to view the most recent error recorded
Fault Name	Displays the name of the fault that occurred



# DIAGNOSTICS menu *(continued)*

**Figure 84** DIAGNOSTICS menu details (continued) (see [Figure 71, page 67](#) for access information)

Menu/Item	Comment
Fault Type	Displays the type of fault that occurred
Time	Displays time that lockout occurred
Date	Displays date that lockout occurred
Status	Displays what the status of the boiler was at the time of the error
Temperatures	Choose this to view the Boiler Temperatures at the time of the error
Inputs	Choose this to view the status of the Boiler Inputs at the time of the error
Outputs	Choose this to view the status of the Boiler Outputs at the time of the error
Lockout History 2	Choose this to view the second most recent error recorded
Fault Name	Displays the name of the fault that occurred
Fault Type	Displays the type of fault that occurred
Time	Displays time that lockout occurred
Date	Displays date that lockout occurred
Status	Displays what the status of the boiler was at the time of the error
Temperatures	Choose this to view the Boiler Temperatures at the time of the error
Inputs	Choose this to view the status of the Boiler Inputs at the time of the error
Outputs	Choose this to view the status of the Boiler Outputs at the time of the error
Lockout History 3	Choose this to view the third most recent error recorded
Fault Name	Displays the name of the fault that occurred
Fault Type	Displays the type of fault that occurred
Time	Displays time that lockout occurred
Date	Displays date that lockout occurred
Status	Displays what the status of the boiler was at the time of the error
Temperatures	Choose this to view the Boiler Temperatures at the time of the error
Inputs	Choose this to view the status of the Boiler Inputs at the time of the error
Outputs	Choose this to view the status of the Boiler Outputs at the time of the error
<b>Manual Test Mode</b>	
Status	Current operating status of the boiler. Prepurge, Ignition, Name of the system Type being satisfied, post purge, Warm Weather Shut down, Trouble
Inputs	Displays which inputs are presently calling for heat
Target	Calculated target temperature based on outdoor temp or the max target if no ODR
Modulation	Displays what sensor the boiler is using to modulate from. May also indicate reason for boiler rate self-limiting.
Boiler Out	Temperature of the outlet sensor on the boiler heat exchanger
Boiler In	Temperature of the inlet sensor on the boiler heat exchanger
System Supply	Temperature of the system water after the boiler loop
System Return	Temperature of the system water returning to the boiler loop
Flue	Temperature of flue gases
Outdoor	Temperature of outdoor air
Blower Signal	Control's signal controlling the blower speed
Blower Speed	Blower's feedback to the control
Flame Signal	Number indicating the presence and quality of the flame used to shut down or boost the boiler
Force Rate	Used to manually force a rate during a call for heat. Choose auto for normal operation
<b>Manual Reset</b>	
	Reset selected condition



# MAINTENANCE, DATE AND TIME menus

Figure 85 MAINTENANCE, DATE AND TIME menus — navigation (see Figure 71, page 67 for access information)

Maintenance Info	Comment
Name	Contractor name to appear in maintenance reminders and during lockouts
Phone	Contractor phone number
Model	Displays the boiler model selected in the boiler setup
CP Number	Enter the CP# of the boiler
Installed	Enter the date the boiler was installed
Last Date	Date automatically entered when Reset Reminder is chosen by contractor
Next Date	Date automatically calculated when Reset Reminder is selected by contractor
Interval Settings	Contractor selects maintenance reminder frequency based on service history
Reset Reminder	Contractor selects this to update Last maintenance Date and Next Date. Homeowner uses this to ignore the reminder and update only the Next Date.

Set Time and Date	
Year	Set year (homeowner or contractor)
Month	Set month (homeowner or contractor)
Day	Set day (homeowner or contractor)
Hour	Set hour (homeowner or contractor)
Minute	Set minute (homeowner or contractor)

## MAINTENANCE INFO

1. Use this section to enter contractor’s information, CP number, install date and to enter an automatic notice for maintenance (default is 12 months). Because this shows on the display, it is an automatic means of notifying the homeowner of need for scheduled maintenance by the technician. Select RESET REMINDER to reset for the next maintenance date.

## SET TIME AND DATE

1. Enter current date and time. This allows correct maintenance reminder timing and provides date and time stamp for lockout histories on ERROR screen in Diagnostic Menu.



# Startup — fill the system

**Figure 86** Tools needed for start-up

Tool	Purpose
#2 Phillips screwdriver	Multiple uses
Flat blade screwdriver	To assemble the condensate trap
Multimeter	Measurements on sensors and electrical components
Manometer (Inclined or digital)	Measure the INLET gas pressure to the boiler
Combustion analyzer (Digital preferred)	Combustion testing and boiler adjustments
Contact thermometer	Checking surface temperatures of heat exchanger and pipes

## Clean system to remove sediment

1. You must thoroughly flush the system (without boiler connected) to remove sediment. The high-efficiency heat exchanger can be damaged by buildup or corrosion due to sediment.

**WARNING** If the system needs to be cleaned, we recommend using Sentinel X400 cleaner, available from Weil-McLain. See [Figure 111, page 117](#) for information. Follow instructions supplied with the X400 cleaner.

2. For zoned systems, flush each zone separately through a purge valve. (If purge valves and isolation valves are not already installed, install them to properly clean the system.)
3. Flush system until water runs clean and you are sure piping is free of sediment.

**WARNING** Do not use petroleum-based cleaning or sealing compounds in boiler system. Damage to elastomer seals and gaskets in system could occur, resulting in substantial property damage. Before filling the boiler and system with water, verify the following. **DO NOT fill with softened water.** Boiler corrosion can occur. Failure to comply could result in boiler failure or unreliable operation.

## Water chemistry

### Water pH requirements

1. Maintain boiler water pH between 7.0 and 8.5. Check with litmus paper or have chemically analyzed by water treatment company.
2. If pH differs from above, consult local water treatment company for treatment needed.

### Hardness requirements

1. Consult local water treatment companies for unusually hard water areas (above 7 grains hardness).

## Chloride concentration requirement

1. Filling with chlorinated fresh water should be acceptable since drinking water chloride levels are typically less than 5 ppm.
2. Do not use the boiler to directly heat swimming pool or spa water.
3. Do not fill boiler or operate with water containing chloride in excess of 200 ppm.

**WARNING** Verify that the water chemistry meets the limitations and requirements of all other equipment in the system.

## Antifreeze

1. Use only antifreeze listed by Weil-McLain as suitable for use with Evergreen® Gas Boilers. See [Figure 111, page 117](#) for information.
2. See [Replacement parts](#) at the end of this manual for Weil-McLain part numbers to obtain antifreeze through a Weil-McLain distributor.

## Use the correct amount of antifreeze

1. Determine the freezing temperature needed (to protect against lowest likely temperature the system water will encounter).
2. Find the antifreeze concentration by volume needed for this temperature from the antifreeze manufacturer's data on the antifreeze container.
3. Add up the volume (gallons) of all system piping and components, including the expansion tank and boiler.
  - a. Boiler water content is listed in [Figure 124, page 130](#).
  - b. Remember to include expansion tank water content.
4. Multiply this volume by the (percent) antifreeze needed to find the number of gallons of antifreeze to add.

## Fill and test water system

1. Fill system only after ensuring the water meets the requirements of this manual.
2. Close manual and automatic air vents and boiler drain valve.
3. Fill to correct system pressure. Correct pressure will vary with each application.
  - a. Typical cold water fill pressure for a residential system is 12 psig.
  - b. Pressure will rise when boiler is turned on and system water temperature increases.
  - c. Pressure should NOT exceed 24 psig when using as shipped, 30 psig relief valve.
  - d. Operating pressure should be no higher than 80% of the relief valve setting for most systems. Operating pressure must never exceed 80 PSIG.
4. At initial fill and during boiler startup and testing, check system thoroughly for any leaks. Repair all leaks before proceeding further.

**WARNING** Eliminate all system leaks. Continual fresh make-up water will reduce boiler life. Minerals can build up in the heat exchanger, reducing heat transfer, overheating heat exchanger, and causing heat exchanger failure.

## Purge air from water system

1. Connect a hose to the purge valve (see purge/drain valves, item 11, in piping diagrams beginning on [page 43](#)). Route hose to an area where water can drain and be seen.
2. Close the boiler or system isolation valve between the purge valve and fill connection to the system.



## Startup — fill the system *(continued)*

### Freeze protection (if used)

**▲WARNING** Follow these guidelines to prevent possibility of severe personal injury, death or substantial property damage:

**Use only the products listed by Weil-McLain for use with this boiler. See page 117 for information.**

**Thoroughly flush any system that has used glycol** before installing the new Evergreen® boiler.

**Review the material safety data sheets (MSDS)** are available online. The MSDS contains information on potential hazards and first aid procedures for exposure or ingestion.

**Check antifreeze inhibitor level at least annually.** Glycol concentration and inhibitor levels may change over time. Add antifreeze to increase concentration if necessary. Add inhibitor as needed to bring to acceptable level, using inhibitor test kit to verify.

In addition to antifreeze and inhibitor, use and maintain minimum level of Sentinel X100 inhibitor as directed on this page.

If using freeze protection fluid with automatic fill, **install a water meter to monitor water make-up.** Freeze protection fluid may leak before the water begins to leak, causing concentration to drop, reducing the freeze protection level.

**DO NOT exceed 50% antifreeze by volume.** Antifreeze moves more sluggishly than water and can interfere with heat transfer. At antifreeze concentrations higher than 50%, sludge can develop in the boiler, potentially causing damage to the heat exchanger.

**Clean the system before filling.** Always drain and flush the system thoroughly before filling with antifreeze. Sludge, iron oxide deposits and other sediment in the system inhibit flow and can cause rapid breakdown of inhibitors.

Use only antifreeze recommended by Weil-McLain.

**NOTICE**

Weil-McLain provides information for application of the antifreeze products listed in this document only for use in Weil-McLain Evergreen® boilers. Do not apply these products or instructions for other applications. Local codes may require a backflow preventer or actual disconnection from city water supply.

3. Close zone isolation valves.
4. Open quick-fill valve on cold water make-up line.
5. Open purge valve.
6. One zone at a time, open the isolation valves. Allow water to run through the zone, pushing out the air. Run until no noticeable air flow is present. Close the zone isolation valves and proceed with the next zone. Follow this procedure until all zones are purged. Follow the same procedure to purge air from the boiler and its internal piping.
7. Close the quick-fill water valve and purge valve and remove the hose. Open all isolation valves. Watch that system pressure rises to correct cold-fill pressure.
8. After the system has operated for a while, eliminate any residual air by using the manual air vents located throughout the system.
9. If purge valves are not installed in system, open manual air vents in system one at a time, beginning with lowest floor. Close vent when water squirts out. Repeat with remaining vents.
10. Open automatic air vent (diaphragm-type or bladder-type expansion tank systems only) one turn.
11. Starting on the lowest floor, open air vents one at a time until water squirts out.
12. Repeat with remaining vents.
13. Refill to correct pressure.

**▲WARNING**

### X100 inhibitor is required

1. It is required that the Evergreen® boiler have Sentinel X100 added to the system to prevent damage to the boilers' heat exchanger. See [Replacement parts](#) for re-ordering information.
2. After filling the system as directed in these instructions, use a caulking gun to inject the X100 inhibitor concentrate into the system, or fill with the X100 in its liquid form, following the instructions on the tube or container.
3. After adding the inhibitor to the system, allow time for the water to circulate and mix. Then check the inhibitor level. Add additional inhibitor if necessary.
4. See separate instructions or Weil-McLain website for suggested guidelines to determine how much inhibitor to use.

### Check/verify water chemistry

1. The system may have residual substances that could affect water chemistry.
2. After the system has been filled and leak tested, verify water pH and chloride concentrations are acceptable.
3. Verify antifreeze concentration, if used.
4. Follow the instructions on the Sentinel test kit to sample the system water and verify inhibitor concentration.

### Check inhibitor concentration annually

1. Test the pH of a sample of system water at least annually. The pH of the water mixture must be between 7.0 and 8.5. (Or use the Sentinel inhibitor test kit to check concentration.)
2. If pH is outside this range (or inhibitor test kit indicates low level), the inhibitor level may not be sufficient to prevent corrosion.
3. Test antifreeze concentration.

**▲WARNING**

Test antifreeze concentration at least annually. If concentration is low, add antifreeze or drain system and refill with correct mixture.

4. Follow instructions on antifreeze container to determine the amount of antifreeze needed. **DO NOT** exceed 50% by volume concentration of antifreeze.
5. Check inhibitor level after adjustments are made.



# Startup — final checks

## **⚠️WARNING** Check for gas leaks

Before starting the boiler, and during initial operation, use a leak detector or smell near the floor and around the boiler for gas odorant or any unusual odor. Remove boiler front door and smell the interior of the boiler jacket. **Do not proceed with startup if there is any indication of a gas leak. Repair any leak at once.**

**DO NOT adjust or attempt to measure gas valve outlet pressure.** The gas valve is factory-set for the correct outlet pressure. This setting is suitable for natural gas and propane, requiring no field adjustment. Attempting to alter or measure the gas valve outlet pressure could result in damage to the valve, causing potential severe personal injury, death or substantial property damage.

**Propane boilers only** — Your propane supplier mixes an odorant with the propane to make its presence detectable. In some instances, the odorant can fade, and the gas may no longer have an odor. Before startup (and periodically thereafter), have the propane supplier verify the correct odorant level in the gas.

## Check thermostat circuits

1. Disconnect wires connected to the Input 1, Input 2 and Input 3 thermostat terminals (see [Field wiring](#), beginning on [page 52](#) for low voltage terminal locations and application information). Mark the wires before removing to avoid wiring errors when re-connecting them.
2. Connect a voltmeter across each pair of incoming wires. Close each thermostat, zone valve and relay in the external circuits one at a time and check the voltmeter reading across the incoming wires.
3. **There should NEVER be a voltage reading.**
4. If a voltage does occur under any condition, check and correct the external wiring.

**⚠️WARNING** **DO NOT connect the thermostat terminals to 3-wire zone valves.** This could cause control damage.

5. Once the external thermostat circuit wiring is checked and corrected if necessary, reconnect the external thermostat circuit wires.

## Inspect/fill condensate system

### Inspect/check condensate lines and fittings

1. Inspect the condensate drain line, condensate PVC fittings and condensate trap. (See [page 49](#) for component locations.)
2. Pour water into the top of the boiler's ½" PVC condensate tee and check for any leaks in the condensate drain line or fittings. Repair any leaks.

## Fill condensate trap with water

1. Loosen the hose clamp securing the right end of the condensate trap to the PVC reducing elbow (see [page 49](#) for details).
2. Slide the trap hose end off of the elbow.
3. Fill the trap with fresh water to within an inch of the end of the hose.
4. Replace trap hose on PVC reducing elbow and tighten the hose clamp.

**⚠️WARNING** The condensate trap must be filled with water during all times of boiler operation to avoid flue gas emission from the condensate drain line. [Prime the condensate trap (by pouring water into the outlet tee while restricting flow in drain tube) if boiler has been out of service for an extended period.] Failure to fill the trap could result in severe personal injury or death.

## Final checks before starting boiler

- Read the instructions to adjust and set up the control module.
- Verify that the boiler model is set correctly in the control, and that it displays correctly.
- Verify that the boiler and system are full of water and all system components are correctly set for operation.
- Fill vent condensate trap with water (by removing hose clamp and hose at PVC reducing elbow). Replace hose on PVC reducing elbow and tighten clamp.
- Verify electrical connections are correct and securely attached.
- Inspect vent piping and air piping for signs of deterioration from corrosion, physical damage or sagging. Verify air piping and vent piping are intact and correctly installed per this manual.

## To start the boiler

1. Follow the Operating Instructions, [Figure 87, page 89](#).
2. The control display will show installed sensors when first powered. Make sure the right sensors are detected and the correct boiler model is identified. If not, determine the cause and correct before proceeding.

## If boiler does not start correctly

1. Check for loose connections, blown fuse or service switch off?
2. Are external limit controls (if used) open? Is boiler water temperature above 200 °F?
3. Are thermostats set below room temperature?
4. Is gas turned on at meter and boiler?
5. Is incoming gas pressure less than the minimum values given on [page 18](#)?
6. Are control settings correct for the application?
7. Is the warm weather shut down activated?
8. If none of the above corrects the problem, refer to Troubleshooting, beginning on [page 102](#).



# Startup — final checks *(continued)*

**Figure 87** Operating instructions (WARNING — Verify that the Control is set for the correct boiler model before proceeding.)

## FOR YOUR SAFETY — READ BEFORE OPERATING



**WARNING** If you do not follow these instructions exactly, a fire or explosion may result causing property damage, personal injury or loss of life.

- |   |  |
|---|--|
| <p>A. This appliance does not have a pilot. It is equipped with an ignition device which automatically lights the burner. Do not try to light the burner by hand.</p> <p>B. Before OPERATING, smell all around the appliance area for gas. Be sure to smell next to the floor because some gas is heavier than air and will settle on the floor. See below.</p> | <p>C. Use only your hand to turn the gas control knob. Never use tools. If the knob will not turn by hand, don't try to repair it, call a qualified service technician. Force or attempted repair may result in a fire or explosion.</p> <p>D. Do not use this appliance if any part has been under water. Immediately call a qualified service technician to inspect the appliance and to replace any part of the control system and any gas control, which has been under water.</p> |
|---|--|

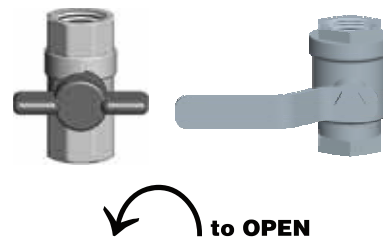
## WHAT TO DO IF YOU SMELL GAS

- Do not try to light any appliance.
- Do not touch any electric switch; do not use any phone in your building.
- Immediately call your gas supplier from a neighbor's phone. Follow the gas supplier's instructions.
- If you cannot reach your gas supplier, call the fire department.

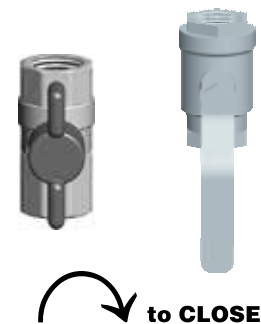
## OPERATING INSTRUCTIONS

1. **STOP!** Read the safety information above on this label. This appliance is equipped with an ignition device which automatically lights the burner. Do not try to light the burner by hand.
2. Set room thermostat(s) to lowest setting.
3. Turn OFF all electrical power to the appliance.
4. Locate boiler manual gas valve (in the gas piping connected to the boiler).
5. Turn boiler manual gas valve knob counterclockwise ↺ to OPEN gas supply.
6. Wait five (5) minutes to clear out any gas. Then smell for gas, including near the floor.
7. If you smell gas, **STOP!** Turn the boiler manual gas valve to OFF. Then follow WHAT TO DO IF YOU SMELL GAS, above. If you don't smell gas, go to step 8, below.
8. Turn ON all electrical power to the appliance.
9. Set thermostat(s) to desired setting.
10. The boiler display will show symbols and/or text describing the status of the boiler as it proceeds through its operating sequence. "Standby" status means the burner is off.
11. If the appliance will not operate when there is a call for heat and piping is not hot, follow the instructions "To Turn Off Gas To Appliance" below and call your service technician or gas supplier.

### Gas valve CLOSED



### Gas valve OPEN



## TO TURN OFF GAS TO THE APPLIANCE

1. Set room thermostats to lowest setting.
2. Turn OFF all electrical power to the appliance.
3. Turn boiler manual gas valve knob clockwise ↻ to close gas supply.

550-101-264 (0614)



# Startup — final checks *(continued)*

## ❑ Check system and boiler

1. Check system piping for leaks. If found, shut down boiler and repair immediately. (See WARNING on [page 86](#) regarding failure to repair leaks.)
2. Vent any remaining air from system using manual vents. Air in the system will interfere with circulation and cause heat distribution problems and noise.

## ❑ Check vent piping and air piping

Check for gas-tight seal at every connection and seam of air piping and vent piping.

**▲WARNING** Venting system must be sealed gas-tight to prevent flue gas spillage and carbon monoxide emissions which will result in severe personal injury or death.

## ❑ Check gas piping

Check around the boiler and inside the boiler jacket for gas odor following the procedure of [page 51](#) of this manual.

**▲WARNING** If you discover evidence of any gas leak, shut down the boiler at once. Find the leak source with bubble test and repair immediately. Do not start boiler again until corrected. Failure to comply could result in severe personal injury, death or substantial property damage.

## ❑ Propane boilers — verify conversion

Verify boiler has been converted for propane. See [page 12](#).

**▲WARNING** **DO NOT attempt to measure gas valve outlet pressure**

DO NOT adjust or attempt to measure gas valve outlet pressure. The gas valve is factory-set for the correct outlet pressure. This setting is suitable for natural gas and propane, requiring no field adjustment.

Attempting to alter or measure the gas valve outlet pressure could result in damage to the valve, causing potential severe personal injury, death or substantial property damage.

Evergreen® boilers are shipped ready to fire natural gas ONLY.

Failure to comply could result in severe personal injury, death or substantial property damage.

## ❑ Check flame & combustion with instruments

1. Initiate a call for heat on one of the thermostat inputs.
2. Access the Evergreen® Control contractor menus by pressing and holding the UP and DOWN arrow keys for seven seconds.
3. Make sure the Max firing rate is set to the maximum given in the table. If not, adjust as necessary. Then navigate to DIAGNOSTICS — Manual test mode (see [page 101](#) for proper instructions on testing a multiple boiler system) and force the firing rate to HIGH (High fire).
4. Look at the flame through the flame inspection window. The high fire flame should be blue and should be stable. The burner surface should be covered with orange dots.

5. **Insert combustion analyzer probe** — Remove the flue temperature sensor from the flue pipe and insert a combustion test probe.
6. Test for CO<sub>2</sub> (or O<sub>2</sub>) and for CO. The CO<sub>2</sub> values must comply with [Figure 88, page 91](#). If results are acceptable, proceed to step 7. **IF NOT**, follow the instructions under “Gas Valve Adjustment” on [page 91](#) to set the throttle screw position.

**▲WARNING**

If combustion at either high or low fire is outside the range given in [Figure 88, page 91](#), follow the procedure given on [page 91](#) for adjusting the throttle screw on the gas valve. If throttle screw adjustment does not correct the problem, then shut down the boiler and contact your local Weil-McLain representative. Throttle screw adjustment must be done only by a qualified technician, using calibrated test instruments. Failure to comply could result in severe personal injury, death or substantial property damage.

7. Measure natural gas input:
  - a. Operate boiler 10 minutes. Turn off other appliances.
  - b. At natural gas meter, measure time (in seconds) required to use one cubic foot of gas.
  - c. Calculate gas input:
 
$$\frac{3600 \times 1000}{\text{number of seconds from step b}} = \text{Btuh}$$
  - d. Btuh calculated should approximate input rating on boiler rating label.
8. Use the control display to navigate to Manual test mode (see [Figure 81, page 81](#)) and force the firing rate to MIN (Low fire).
9. Look at the flame through the flame inspection window. The low fire flame should be stable and evenly distributed over burner surface with a uniform orange color.
10. Repeat the combustion test as instructed in the previous steps.
11. Use the control display to navigate to Manual test mode (see [Figure 81, page 81](#)) and force the firing rate to AUTO (normal operation).
12. Reinstall the flue gas temperature sensor. When replacing the sensor, remove the rubber grommet from the probe. Insert the rubber grommet into the flue pipe, then insert the probe into the rubber grommet.

**▲WARNING**

You must reinstall the flue gas temperature sensor to prevent flue gas spillage into the boiler enclosure. Failure to comply could result in severe personal injury, death or substantial property damage.



# Startup — final checks *(continued)*

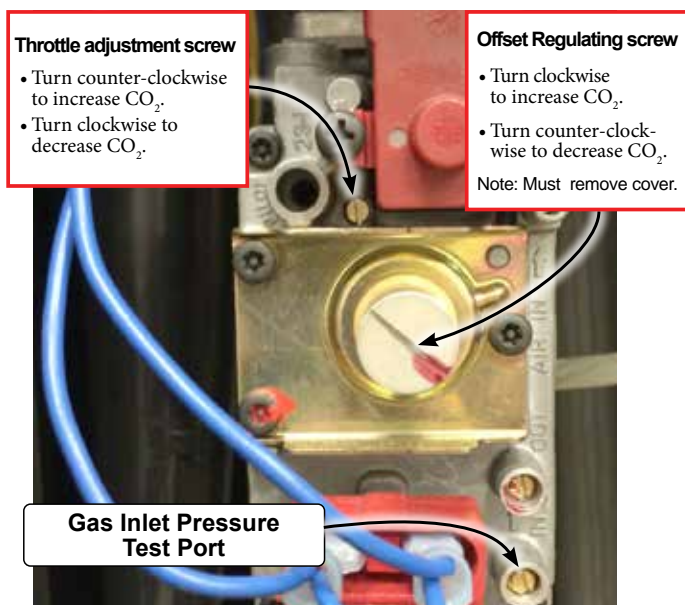
## Gas Valve Adjustment

**⚠ WARNING** DO NOT attempt to adjust the throttle or offset screw unless done by a qualified technician, and with the use of calibrated combustion test instruments. Adjust the throttle or offset screw only as needed to meet the combustion values given in Figure 89. Must confirm correct low fire RPM before making any adjustments to Offset regulating screw.

1. Throttle screw adjustment is **only necessary** if specified elsewhere in this manual or if combustion tests indicate the need, as explained under “**Check flame & combustion with instruments,**” page 90.
2. Boiler behavior that might indicate a need to check combustion values at high fire (as per page 90) to verify boiler is in adjustment include: difficulty igniting, poor flame stability at low fire, combustion noise or high carbon monoxide values.
3. Combustion readings must be taken at both high fire and low fire. DO NOT attempt an adjustment of the throttle screw at low fire.
  - See Figure 88 for location of the throttle screw. Remove the cover screw to access the throttle adjustment screw.

**⚠ CAUTION** Adjust the throttle adjustment screw in small movements.

**Figure 88** Throttle screw (ONLY for use by a qualified technician, using calibrated combustion test instruments)



### High Fire

Make sure the Max firing rate is set to the maximum and confirm the rpm valve during operation given in the table Figure 96, page 100. If not, adjust as necessary. Then navigate to DIAGNOSTICS — Manual test mode (Figure 81, page 81) and force the firing rate to HIGH (maximum output). After the boiler has had time to stabilize, take a CO<sub>2</sub> and CO readings.

- a. If the CO<sub>2</sub> is HIGH, turn the throttle screw CLOCKWISE to lower the input. Allow the boiler to stabilize and take another reading. Continue until the desired CO<sub>2</sub> value is achieved.
- b. If the CO<sub>2</sub> is LOW, turn the throttle screw COUNTERCLOCKWISE to increase the input. Allow the boiler to stabilize and take another reading. Continue until the desired CO<sub>2</sub> value is achieved.
- c. Confirm that the CO is within limits.

**Figure 89** Acceptable combustion values — measured values must be within the ranges given below

Boiler model	Fuel	High fire		Low fire	
		% CO <sub>2</sub>	CO ppm	% CO <sub>2</sub>	CO ppm
220	NG	9.25 ± 0.5	< 100	8.75 ± 0.5	< 50
	LP	10.25 ± 0.25	< 120	9.75 ± 0.25	< 50
299/300	NG	9.25 ± 0.5	< 100	8.75 ± 0.5	< 50
	LP	10.75 ± 0.5	< 120	10.25 ± 0.5	< 50
399	NG	9.25 ± 0.5	< 100	8.75 ± 0.5	< 50
	LP	10.75 ± 0.5	< 120	10.25 ± 0.5	< 50

- Values above are with the boiler front door removed. Values will increase about 0.2% once the door is reinstalled.
- REINSTALL the boiler door after completing service.
- The low fire CO<sub>2</sub> listed is typical. The valve may vary with conditions, but must be 0.35% to 0.75% lower than the high fire CO<sub>2</sub> value.

### Low Fire

1. Adjust the boiler to (LOW) (minimum output) and allow the boiler to stabilize. Confirm the rpm valve during operation with the table Figure 96, page 100.
2. Remove the slotted cap, see Figure 88, for Offset screw adjustment.
  - a. If the CO<sub>2</sub> is HIGH, turn the offset regulating screw COUNTERCLOCKWISE to lower the input. Allow the boiler to stabilize and take another reading. Continue until the desired CO<sub>2</sub> value is achieved.
  - b. If the CO<sub>2</sub> is LOW, turn the regulating screw CLOCKWISE to increase the input. Allow the boiler to stabilize and take another reading. Continue until the desired CO<sub>2</sub> value is achieved.
  - c. Confirm that the CO is within limits.

### Re-check the Maximum and Minimum CO<sub>2</sub> and CO rate

1. Turn off the boiler and then turn it back on and put in Test Mode at maximum. Ensuring the CO<sub>2</sub> setting level has remained unchanged and confirm that CO is within limits.
2. Reduce to minimum and re-check the minimum rate output ensuring the CO<sub>2</sub> setting level has remained unchanged and confirm that CO is within limits.
3. In the event that the CO<sub>2</sub> and CO cannot be obtained, please contact your Weil-McLain representative.
4. Should you require any assistance during the set up procedure contact your Weil-McLain representative if the problem cannot be addressed with the information provided in this manual.

### ☐ Check ignition system safety shutoff device

1. After the boiler has been installed, turn off the boiler.
2. Shut off the manual gas valve located on the gas line to stop flow of fuel to the boiler.
3. Turn on the boiler. It will start the ignition sequence, but will not light. After some time, the boiler will lockout, the display screen will turn red, and the Control will flash “Ignition Fault”. It means that the boiler tried to ignite without success for five (5) times and went into Lockout mode. This means that the ignition system safety device worked properly.
4. Clear the Lockout condition by selecting “Manual Reset” in the Diagnostic Menu.
5. Open the manual gas valve located on the gas line to resume fuel supply to the boiler.



## Startup — final checks *(continued)*

### Check Heat exchanger and vent seals

1. Operate the boiler on HIGH fire.
2. Using an inspection mirror, move the mirror around all heat exchanger joints and vent pipe connections at the top of the boiler and at the connection to the condensate dish.
3. A leak would appear as vapor on the surface of the mirror.
4. If there is any indication of a leak at any joint, immediately shut down the boiler.
  - a. If possible, tighten the retaining screws or nuts (without over-tightening).
  - b. If this does not correct the problem, disassemble the components where the leak appeared. Use the procedures given in [Maintenance](#).
5. Condensate dish joint
  - c. When disassembling components, inspect gaskets to see if there is damage. Replace any damaged gasket.
  - d. Contact your Weil-McLain representative if the problem cannot be addressed with the information provided in this manual.

### 5. Condensate dish joint

- a. If the inspection mirror check shows a leak at the condensate dish-to-heat exchanger joint.

or

If the mirror test does not reveal a leak at the condensate dish joint, but there are signs of weepage or other indications that there might be leakage, the boiler must not be operated until a new sealing ring is obtained. Follow the instructions supplied with the sealing kit to disassemble boiler components as necessary to access and replace the seal.

## Check-out/startup verification

### Adjust and test boiler controls

1. Follow instructions in this manual to set and verify operation of the boiler controls.
2. Follow low water cutoff manufacturers instructions (If installed).

### Have the following been done?

- Control set for the correct boiler model?
- Installation date and installer contact information entered into Control?
- Boiler and heat distribution units filled with water?
- Water chemistry verified per [page 86](#)?
- Sentinel X100 corrosion inhibitor added and water tested to be within range?
- Automatic air vents, if used, opened one full turn?
- Air purged from system?
- Air purged from gas piping? Piping checked for leaks?
- Condensate line primed?
- Propane venturi installed for propane firing and propane conversion label affixed to jacket?

**⚠ WARNING** Evergreen® boilers are shipped ready to fire natural gas ONLY. To fire on propane, you must follow the instructions in this manual to install the propane venturi kit. See [page 12](#). Failure to comply could result in severe personal injury, death or substantial property damage.

- Thermostat circuit wiring checked to ensure there are no stray voltages?
- Followed Operating Instructions, [Figure 87](#), [page 89](#)?
- Burner flame and combustion verified per [pages 90](#) and [91](#)?

- Control operation for space heating and DHW (if used) verified per this manual?

- Additional field-installed controls tested as outlined by control manufacturers? (Boiler should be operating and should go off when controls are tested. Verify controls cause automatic reset lockout or manual reset lockout as desired.)

- Additional field-installed limit control(s) set to system temperature requirements? Balancing valves and controls adjusted to provide design temperature to system?

- Flow adjusted/balanced for each zone of multiple zones systems?

- Thermostat heat anticipator (if available) set properly?

- Boiler cycled with thermostats (and with DHW aquastat, if installed) — Raised to highest setting and verified boiler goes through normal startup cycle? Lowered to lowest setting and verified boiler goes off?

- Natural gas input measured? ([page 90](#))

- Incoming gas pressure checked by connecting manometer to gas valve ahead of boiler? (Gas pressure must be at least the minimum values given on [page 18](#), with boiler operating at high fire, and no more than 14 inches (356 mm) w.c. with boiler operating or boiler off.)

- Observed several operating cycles for proper operation?

- Room thermostats set to desired room temperature (and DHW aquastat, if installed, to desired DHW storage temperature)?

- All instructions shipped with this boiler reviewed with owner or maintenance person?

### Before leaving:

- Fill in **Installation certificate**, [page 131](#).

- Return instructions to envelope and give to owner or place inside boiler housing.

**NOTICE**

Fill out start-up data on the Installation and Service Certificate, [page 131](#).



# Annual startup and general maintenance

**WARNING** Follow the service and maintenance procedures given throughout this manual and in component literature shipped with the boiler. Failure to perform the service and maintenance could result in damage to the boiler or system. Failure to follow the directions in this manual and component literature could result in severe personal injury, death or substantial property damage.

**Figure 90** Service and maintenance schedules

<b>Service technician</b> (see page numbers indicated for details)		<b>Owner maintenance</b> (see Evergreen® User's Information Manual)			
<b>ANNUAL START-UP (See First-year special inspection)</b>	• Handling ceramic fiber materials . . . . .	94	<b>Daily</b>	• Check boiler area.	
	• First-year special inspection . . . . .	94		• Check air openings.	
	• Address reported problems . . . . .	95		• Check pressure/temperature gauge.	
	• Inspect boiler area . . . . .	95	<b>Monthly</b>	• Verify boiler front door is securely in place.	
	• Inspect boiler interior & door gaskets . . . . .	95		• Check vent piping.	
	• Clean condensate trap . . . . .	95		• Check air piping.	
	• Check all piping for leaks . . . . .	96		• Check relief valve.	
	• Check air openings. . . . .	96		• Check condensate drain system.	
	• Inspect flue vent system and air piping . . . . .	96		• Check automatic air vents (if used).	
	• Check water system . . . . .	96		• Verify that domestic hot water is being supplied to fixtures at the correct temperature. (If Indirect Tank installed)	
	• Remove the burner access panel . . . . .	96		<b>Every 6 months</b>	• Check boiler piping (gas and water).
	• Remove and inspect ignition electrode assembly and wiring . . . . .	97			• Operate relief valve.
	• Remove and inspect flame sense rod and wiring . . . . .	97			
	• Remove, inspect and clean the burner. . . . .	97			
	• Inspect combustion chamber and refractory. . . . .	97			
	• Replace all components . . . . .	98			
	• Check all boiler wiring . . . . .	99			
	• Check control settings . . . . .	99			
	• Inspect pressure switch, wiring and tube . . . . .	99			
	• Perform startup and checks . . . . .	99			
• Check low water cutoff service light . . . . .	99				
• Check burner flame and flame signal . . . . .	99				
• Check blower speeds . . . . .	100				
• Check flue gas temperature . . . . .	100				
• Check boiler relief valve . . . . .	101				
• Reinstall jacket door after servicing . . . . .	101				
• Review with owner . . . . .	101				



# Annual startup

## FIRST-YEAR SPECIAL INSPECTION

### NOTICE

It is recommended that you obtain a Weil-McLain Evergreen® Boiler Maintenance kit before attempting the first-year inspection, to ensure all parts that may be needed are available. This kit includes essential components, gaskets and seals required to perform the annual start-up procedures. See listing in [Replacement parts](#). These parts must be on hand when you perform the first-year inspection in the event they must be replaced.

### WARNING

Failure to replace the items above when needed could result in severe personal injury, death or substantial property damage.

1. **No later than 12 months** after the boiler is installed, perform a first-year inspection of the boiler. This should include the following **in addition to routine annual start-up procedures**.
  - a. Inspect the heat exchanger and clean if necessary (see [page 111](#) for access and cleaning procedures).
  - b. Inspect the cover plate refractory and gasket. Replace if not in good condition.
  - c. Inspect the burner carefully. Clean the burner thoroughly using a vacuum cleaner or compressed air if needed.
  - d. Make sure there is no blockage or accumulation of debris in the burner or the burner ports. Replace the burner if necessary.
  - e. Check the burner for tightness.
  - f. Disconnect the condensate trap and drain lines. Inspect, then flush thoroughly. Reinstall and refill the trap per [page 88](#).
  - g. Check heat exchanger seals and vent seals, procedure described on [page 92](#), “Check exchanger and vent seals”.
2. Determine any follow-up maintenance and service needs based on the condition of the heat exchanger and condensate lines.
  - a. If the heat exchanger shows substantial fouling, or if condensate lines show accumulation of sediment, schedule a follow-up service call to perform the first-year inspection again, sooner than the normal twelve months between.
  - b. Heavy fouling of the exchanger or condensate lines indicates possible combustion air contamination. Inspect the air intake area carefully, and remove possible contaminants. See [page 19](#), for products to avoid.

### WARNING

You must eliminate causes of corrosion and contamination to ensure reliable operation of the boiler and system.

## ANNUAL STARTUP

### WARNING

The boiler should be inspected and started annually, at the beginning of the heating season, only by a qualified service technician. In addition, the maintenance and care of the boiler designated in [Figure 90, page 93](#) and explained on the following pages must be performed to assure maximum boiler efficiency and reliability. Failure to service and maintain the boiler and system could result in equipment failure.

## TOOLS REQUIRED

Before beginning annual start-up or first-year special inspection, obtain the tools listed on [page 102](#).

## HANDLING CERAMIC FIBER MATERIALS

### REMOVING COVER PLATE REFRACTORY

### WARNING

The Evergreen® cover plate refractory contains ceramic fiber materials that have been identified as carcinogenic, or possibly carcinogenic, to humans. Ceramic fibers can be converted to cristobalite in very high temperature applications. The International Agency for Research on Cancer (IARC) has concluded, “Crystalline silica inhaled in the form of quartz or cristobalite from occupational sources is carcinogenic to humans (Group 1)”:

- Avoid breathing dust and contact with skin and eyes.
  - Use NIOSH certified dust respirator (N95). This type of respirator is based on the OSHA requirements for cristobalite at the time this document was written. Other types of respirators may be needed depending on the job site conditions. Current NIOSH recommendations can be found on the NIOSH web site at <http://www.cdc.gov/niosh/homepage.html>. NIOSH approved respirators, manufacturers, and phone numbers are also listed on this web site.
  - Wear long-sleeved, loose fitting clothing, gloves, and eye protection.
- Handle carefully to minimize dust that could be caused by abrasion.
- If replacement is necessary, remove the refractory from the boiler and place it in a plastic bag for disposal.
- Wash potentially contaminated clothes separately from other clothing. Rinse clothes washer thoroughly.

### NIOSH stated First Aid

- Eye: Irrigate immediately.
- Breathing: Fresh air.



## Annual startup *(continued)*

**⚠ WARNING** DO NOT SERVICE THE BOILER WITHOUT AN Evergreen® INSPECTION KIT AVAILABLE

Before each annual inspection, obtain an EVG Inspection Kit, which includes parts required for the procedures given in this manual. It is recommended to also obtain an EVG Maintenance Kit, which includes additional parts that may be required if inspection of components indicates the need for replacement. See [Replacement parts](#) for kit part numbers.

### Disconnect power

**⚠ WARNING** **ELECTRICAL SHOCK HAZARD** — Disconnect all electrical power to the boiler before attempting maintenance procedures. Failure to complete could result in severe personal injury, death or substantial property damage.

### Reinstall boiler jacket door after startup or servicing

**⚠ WARNING** Reinstall boiler jacket door after start-up or servicing. The boiler front door must be securely fastened to the boiler to prevent boiler from drawing air from inside the boiler room. This is particularly important if the boiler is located in the same room as other appliances.

Inspect boiler jacket door gaskets. Gaskets must be in good condition, with no tears or gaps. Replace if necessary.

Failure to keep the door securely sealed and fastened could result in severe personal injury or death.

### Start-up and check/out

**⚠ WARNING** Removing and reinstalling components can change boiler behavior. After any maintenance procedure, you must prove the boiler is operating correctly. To do so, follow the complete procedure for boiler and system start-up, beginning on [page 86](#). Failure to comply could result in severe personal injury, death or substantial property damage.

### Address reported problems

Inspect any problems reported by owner and correct before proceeding.

### Inspect boiler area

1. Verify that boiler area is free of any combustible materials, gasoline and other flammable vapors and liquids.
2. Verify that air intake area is free of any of the contaminants listed on [page 19](#) of this manual. If any of these are present in the boiler intake air vicinity, they must be removed. If they cannot be removed, reinstall the air and vent lines per this manual.

### Inspect boiler interior & door gaskets

1. Remove jacket front door and inspect interior of boiler.
2. Visually inspect the door gaskets. Make sure all are in good condition. Obtain replacements if any gasket is damaged.

**⚠ WARNING** Door gaskets must be intact, and must provide a reliable seal. Replace any damaged gasket.

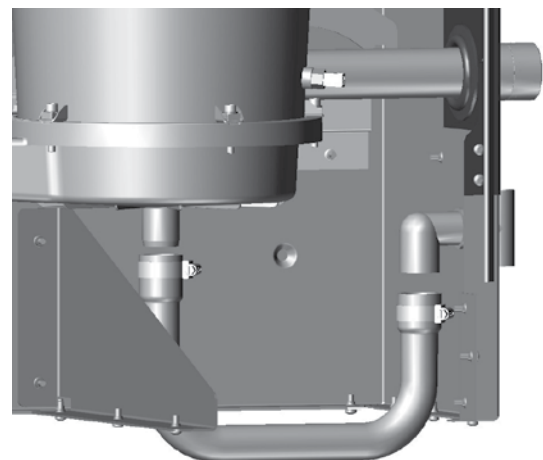
3. Remove the venturi air inlet silencer and clean if necessary. Reinstall silencer.
4. Vacuum any sediment from the inside of the boiler and components. Remove any obstructions.

**⚠ WARNING** Do not use solvents to clean any of the boiler components. The components could be damaged, resulting in unreliable or unsafe operation.

### Clean condensate trap

1. See Figure 91. Loosen condensate trap line hose clamps and remove trap line.
2. Empty water from trap line and inspect. Flush out if needed with fresh water.
3. Check condensate elbow, tee, and condensate line to drain. Flush if necessary to clean.
4. Fill trap with fresh water.
5. Reinstall condensate trap line and tighten hose clamps.

**Figure 91** Condensate drain line cleaning





## Annual startup *(continued)*

### Check all piping for leaks

**⚠WARNING** Eliminate all system or boiler leaks. Continual fresh make-up water will reduce boiler life. Minerals can build up in the heat exchanger, reducing heat transfer, overheating heat exchanger, and causing heat exchanger failure. Leaking water may also cause severe property damage.

1. Inspect all water and gas piping and verify to be leak free.
2. Look for signs of leaking lines in the system and in the boiler and correct any problems found.
3. Check gas line using procedure on [page 51](#).

### Check air openings

1. Verify that combustion and ventilation air openings to the boiler room and/or building are open and unobstructed.
2. Check operation and wiring of automatic combustion air dampers, if used.
3. Verify that boiler vent discharge and air intake are clean and free of obstructions.

### Inspect flue vent system and air piping

Visually inspect entire flue gas venting system and combustion air piping for blockage, deterioration or leakage. Proper replacement of damaged components, reassembly, and resealing of the vent-air intake system must be done if any of these signs are present in accordance with the vent manufacturer's instructions. Verify that air inlet piping is connected and properly sealed.

**⚠WARNING** Failure to inspect for the above conditions and have them repaired can result in severe personal injury or death.

### Check water system

1. Verify all system components are correctly installed and operational.
2. Check the cold fill pressure for the system. Verify it is correct (usually around 12 PSIG).
3. Watch the system pressure as the boiler heats up (during testing) to ensure pressure doesn't rise too high. Excessive pressure rise indicates expansion tank sizing or performance problem.
4. Inspect automatic air vents and air separators. Remove air vent caps and briefly press push valve to flush vent. Reinstall caps. Make sure vents do not leak. Replace any leaking vents.
5. Check system water chemistry (pH, hardness and inhibitor level). See [page 86](#).

### Check expansion tank(s)

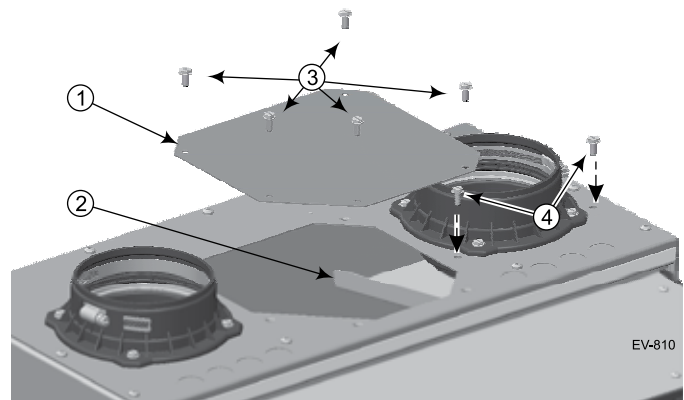
1. Expansion tanks provide space for water to move in and out as the heating system water expands due to temperature increase or contracts as the water cools.
2. Tank types — see [page 42](#).
  - **Closed-type** — welded gas tight and located above boiler. Tank is partially filled with water, leaving an air cushion for expansion.

- Make sure a closed-type tank is fitted with a tank fitting, such as the B & G Tank-Trol or Taco Taco-Trol. This fitting reduces gravity circulation of air-saturated tank water back to the system and prevents the air from bubbling up through the water as it returns from the system.
  - Do not use automatic air vents in systems with closed-type tanks. The air will escape from the system instead of returning to the tank.
  - Eventually, the tank will waterlog and no longer control pressurization. The boiler relief valve will weep frequently.
- **Diaphragm- or bladder-type** — welded gas tight with a rubber membrane to separate the tank pressurizing air and the water. May be located at any point in the system, but preferably located on the suction side of the system circulator.
    - Systems with this type of expansion tank require at least one automatic air vent, preferably located on top of an air eliminator, as shown in examples in this manual.
3. If relief valve has tended to weep frequently, the expansion tank may be waterlogged or undersized.
    - a. **Diaphragm- or bladder-type expansion tank** — first, check tank size to be sure it is large enough for the system. If size is too small, add additional tank (or tanks) as necessary to provide sufficient expansion. If tank size is large enough, remove tank from system and check charge pressure (usually 12 PSIG for residential applications). If tank won't hold pressure, membrane has been damaged. Replace tank.
    - b. **Closed-type expansion tank** — tank is most likely waterlogged. Install a tank fitting if not already installed. Then check fill level per fitting manufacturer's instructions. If fill level is correct, check tank size against manufacturer's instructions. Replace with a larger tank if necessary.

### Remove the burner access panel

1. See Figure 92.
2. Remove the burner access panel (item 1) located on the top of the boiler jacket by removing the screws (item 3).

**Figure 92** Remove the burner access panel and screws (1 and 3) and air baffle and screws (2 and 4) from the jacket top as shown below





## Annual startup *(continued)*

- Remove the air baffle (item 2) and screws (item 4) from the jacket top as shown.

### Remove and inspect ignition electrode assembly and wiring

- See [Figure 93, page 98](#) (EVG 220 shown) for component references below.
- Disconnect the ground wire and ignition cable connected to the ignition electrode assembly (item 7).
- Use a 3 mm Allen wrench to remove the two (2) screws securing the ignition electrode assembly to the heat exchanger cover plate (item 6).
- Carefully remove the ignition electrode assembly from the heat exchanger cover plate.
- Discard the ignition electrode assembly gasket.
- Inspect the ignition electrodes and ceramic insulators.
  - Remove any white oxides accumulated on the ignition electrodes using steel wool.
  - Clean the gasket surfaces on the ignition electrode assembly flange and on the mating surface of the heat exchanger cover plate.
  - If the ignition electrode ceramic is cracked or damaged, or if the electrodes cannot be cleaned satisfactorily, replace the ignition electrode assembly with a new one.
- Slide the new gasket onto the ignition electrode assembly.
- Set the ignition electrode assembly with new gasket aside for later re-insertion.
- Check ignition cable electrical resistance.
  - A good cable will have resistance between 950 and 1050 ohms.
  - Replace cable if not acceptable.
- Verify all wiring is in good condition and securely attached.
- Inspect boiler ground wire from heat exchanger access cover to ground terminal screw in control tray.
  - Check resistance. It should be 0 ohms.
  - Check ground continuity of wiring using continuity meter.
  - Replace ground wires if results are not satisfactory.

### Remove and inspect flame sense rod and wiring

- See [Figure 93, page 98](#) (EVG 220 shown) for component references below.
- Disconnect the flame sense wire connected to the flame sense rod (item 8).
- Use a 3 mm Allen wrench to remove the two screws securing the flame sense rod assembly to the heat exchanger cover plate. Carefully remove the flame sense rod.
- Discard the flame sense rod gasket.
- Inspect the flame sense rod and ceramic.
  - Remove any white oxides accumulated on the flame sense rod.
  - Clean the gasket surfaces on the flame sense assembly flange and on the mating surface of the heat exchanger cover plate.

- If the flame sense rod is bent or cannot be cleaned satisfactorily or if the ceramic is cracked or damaged, replace the flame sense rod assembly with a new one.
- Slide the new gasket onto the flame sense rod assembly.
  - Inspect flame sense wire from flame sense connector to the connector at the control module in boiler control tray.
    - Check resistance. It should be 0 ohms.
    - Replace Wire Harness– Low Voltage if results are not satisfactory.

### Remove, inspect and clean the burner

- See [Figure 93, page 98](#) (EVG 220 shown).
- Use a Phillips stubby screwdriver to remove the four (4) M4 screws (item 10) that secure the burner access cover (item 4) to the heat exchanger cover plate (item 6).
- Remove the burner access cover (item 4) and the burner (item 11).



Use caution when removing the burner to pull it directly up and out. DO NOT angle the burner as you remove it. Angling the burner could cause it to strike the refractory, damaging the refractory and causing fragments to fall into the heat exchanger. Should this happen, a heat exchanger refractory replacement kit must be installed and the heat exchanger must be thoroughly cleaned following the procedures given in this manual and the refractory replacement instructions.

- Remove and discard the burner gasket (item 12). This gasket is graphite and may pull apart or stick to the burner on removal. Use a soft brush if necessary to remove residue. DO NOT allow debris to drop into the heat exchanger. A new gasket must be installed later when the burner is re-inserted.
- Inspect the burner access cover seal (item 13). Discard and use a new seal during re-assembly if the seal is damaged in any way.
- Inspect the interior of the burner. Brush and vacuum the interior if needed to remove lint or sediment. Alternative cleaning methods:
  - Blow air or nitrogen from the inside out.
  - Clean with a water spray from inside the burner.
- Inspect the burner exterior. It must be in good condition, with no visible damage.
- Clean the under side of the burner flange (see item 15) with a soft brush to remove any gasket fragments remaining.
- Set the burner aside for re-insertion later.

### Inspect combustion chamber and refractory

- Look into the burner opening in the heat exchanger cover plate.
- Use a trouble light and inspection mirror to inspect the heat exchanger interior.
  - Make sure that there is no debris inside the heat exchanger.
  - Use the inspection mirror to check the condition of the burner refractory that is adhered to the bottom of the heat exchanger cover plate. It must be in good condition with no indication of damage or sagging.



# Annual startup *(continued)*

## LEGEND — Figure 93 PARTS A and B

- A** Boiler interior assembled view (Model EVG 220 shown; component locations vary with other models)
- B** Boiler interior exploded view, showing heat exchanger cover plate (item 6) blower, burner assembly, burner access cover seal (item 13), ignitor, flame sense rod, and sight glass.
- 1 Inlet air silencer
  - 2 Blower assembly
  - 3 Gas valve
  - 4 Burner access cover
  - 5 Venturi assembly
  - 6 Heat exchanger cover plate
  - 7 Ignition electrode assembly
  - 8 Flame sense rod
  - 9 Heat exchanger cover plate retainer nuts (6) M6 hex
  - 10 Burner cover retainer screws, M4 Phillips with captive washers
  - 11 Burner
  - 12 Burner gasket
  - 13 Burner access cover seal
  - 14 Burner gasket sealing surface
  - 15 Burner sealing surface (lower surface of burner flange)

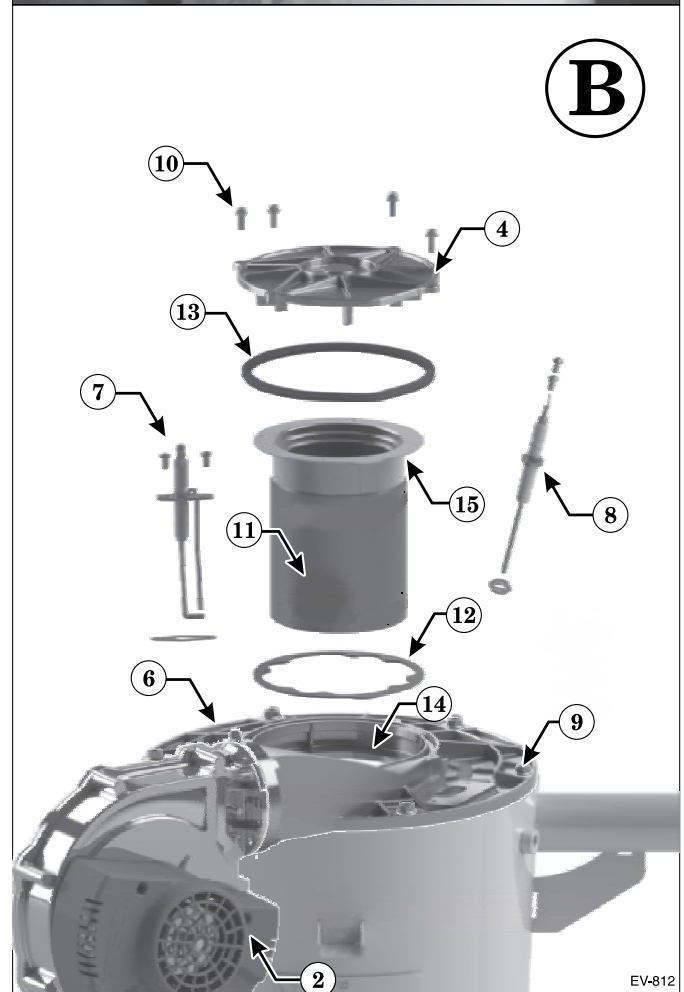
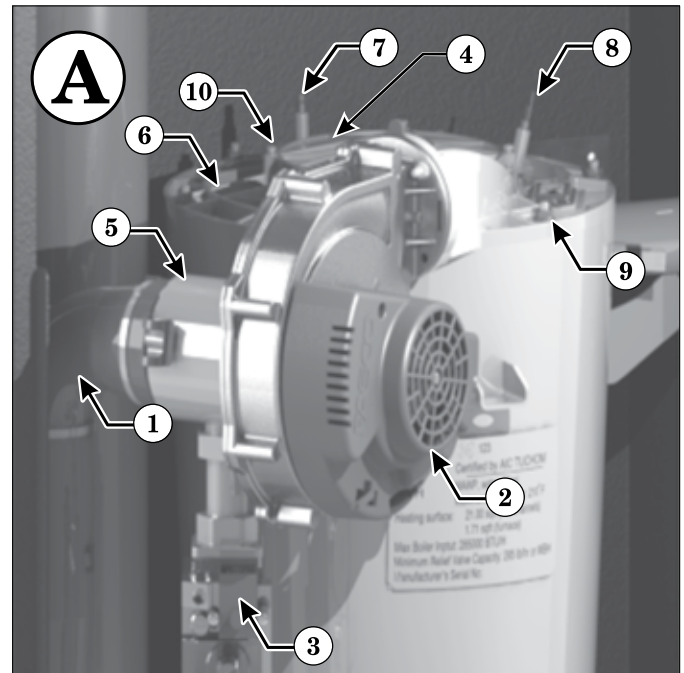
c. Make sure there are no signs of overheating or of flue gas leakage.

**⚠ WARNING** If visual inspection of the heat exchanger indicates the need, follow the procedures in “Cleaning the heat exchanger FLUE SIDE or accessing the burner, when required” on [page 111](#) to remove the heat exchanger cover plate and fully inspect and clean the interior. Obtain replacement parts for any components that may be damaged or that show signs of leakage.

## Replace all components

1. Reinstall the burner.
  - a. Insert a new burner gasket (item 12) into the heat exchanger cover plate (item 4).
  - b. Insert the burner into position.
  - c. Insert the burner access cover seal into the heat exchanger cover plate.
  - d. Place the burner access cover (item 4) into position and secure the four screws (item 10).
2. Reinstall ignition electrode assembly and gasket, making sure that it is correctly positioned. Tighten the two (2) screws securely.
  - a. Re-attach igniter cable and ground wire to the ignition electrode assembly.
3. Reinstall flame sense rod assembly and gasket, making sure that it is correctly positioned. Tighten the two (2) screws securely.
  - a. Re-attach the wire to the flame sense rod.
4. Reinstall the burner access panel and air baffle (see [Figure 92, page 96](#)). Tighten screws securely.

**Figure 93** Accessing burner, ignition electrode, flame sense rod and inspection glass assembly (EVG 220 shown)





# Annual startup *(continued)*

## Check all boiler wiring

1. Inspect all boiler wiring, making sure wires are in good condition and securely attached.
2. Verify that all connectors are securely inserted.
3. Verify ground wires are connected to jacket right side and control tray cover.

## Check control settings

1. Use the Control display to navigate through all settings. Adjust settings if necessary.
2. Check settings of external limit controls (if any) and adjust if necessary. Adjust as needed to accommodate the system design.

## Inspect pressure switch, wiring and tube

1. Inspect pressure switch, ensuring wire connects are properly connected and tube is secured to pressure port.
2. Inspect tube for any signs of damage or debris collected in tube, replace if necessary.
3. After checking Control Settings (see above), disconnect tube connection with condensate dish. Gently blow on tube until pressure switch opens and control displays lockout error. Clear lockout on control and confirm that lockout does not re-appear. Reconnect tube connection with condensate dish, making sure connection is secure.

## Perform startup and checks

1. Start boiler and perform checks and tests specified in this manual.
2. Verify cold fill pressure is correct and that operating pressure does not go too high. Adjust water pressure and expansion tank charge pressure as necessary.
3. Complete the check-out procedure on [page 92](#).

## Check low water cutoff service light

1. If the low water cutoff amber LED is on, the LWCO requires service.
2. Follow the manufacturer's instructions packed with the low water cut-off (shipped as standard equipment with all Evergreen boilers, in the kit box).

## Check burner flame and flame signal

**⚠WARNING** The boiler contains ceramic fiber materials. Use care when handling these materials per instructions on [page 94](#) of this manual. Failure to comply could result in severe personal injury.

1. Inspect flame through observation window using the procedure on [page 90](#).
2. If flame is unsatisfactory at either high fire or low fire, check combustion values. If combustion is properly adjusted, turn off boiler and allow boiler to cool down. Then remove burner and clean it thoroughly using a vacuum cleaner or compressed air. Do not use compressed air to clean burner if performed inside a building.
3. To access the burner, remove the burner access panel and the cover plate top following the procedure beginning on [page 111](#).

**Figure 94** Minimum flame signal values during operation

Model	Minimum flame signal	Model	Minimum flame signal
EVG 220	100	EVG 220 LP	100
EVG 299/300	100	EVG 299/300 LP	100
EVG 399	124	EVG 399 LP	100

**Figure 95** Flame signal shut down values — the control will shut the boiler down if flame signal levels drop below the values below

Model	Shut down flame signal	Model	Shut down flame signal
EVG 220	80	EVG 220 LP	80
EVG 299/300	80	EVG 299/300 LP	80
EVG 399	104	EVG 399 LP	80

4. If removing the cover plate top and /or the burner, the burner gasket must be replaced. Follow all instructions on [page 114](#) to reinstall all components.
5. Restart the boiler.
6. Inspect the flame at high and low fire. If flame is still not acceptable, check combustion values, [Figure 89, page 91](#). If combustion can not be properly adjusted, obtain a replacement burner from Weil-McLain.
7. Check flame signal at both high fire and low fire.
8. Navigate to Diagnostics/Inputs on the Control display (see [Figure 74, page 75](#) for navigation instructions and [Figure 80, page 80](#) for the complete Diagnostics menus).
9. The flame signal value must be at least equal to the values listed in [Figure 94](#).
10. If the flame signal drops below this level, the Control will attempt to correct by increasing the boiler firing rate to increase flame signal.
11. A low flame signal may indicate a fouled flame sense rod.
  - a. See “Inspect Flame Sense Rod,” [page 97](#) to remove and inspect the flame sense rod.
  - b. If required, clean the flame sense rod as instructed.
  - c. Check combustion values.
  - d. If cleaning the flame sense rod does not improve, flame sense wiring is in good condition, and ground continuity is satisfactory, replace the flame sense rod.
12. If flame signal still remains low:
  - a. See “Remove, Inspect and Clean the Burner,” see [page 111](#) to remove and replace burner gasket.
  - b. Inspect the vent and air piping.
  - c. Then inspect the heat exchanger, following the procedures given in this manual for removal and reinstallation of the heat exchanger cover plate and other boiler components (see [page 111](#)).
  - d. Clean the exchanger as described in this manual if necessary.



# Annual startup *(continued)*

## Check blower speeds

1. For installations at altitudes above 2,000 feet, make sure the control is set up for correct altitude in the boiler setup menu. The Control automatically adjusts low fire and ignition rates to compensate for high altitude conditions.
2. Use the Control display to navigate to DIAGNOSTICS/Manual test mode (see [Figure 74, page 75](#) for navigation instructions and [Figure 80, page 80](#) for the complete Diagnostics menus).
3. Set the firing rate to MINIMUM (low fire).
4. Write down the blower RPM value shown and compare to the value in Figure 96. The value should no less than the “Minimum setting” and no higher than the Ignition “Factory setting” listed. Low fire rate (% of Max Rate) is adjusted in the “Priority” setup menu.
5. Set the firing rate to MEDIUM (ignition rate).
6. Write down the blower RPM value. It should be within 200 RPM of the value listed in Figure 96.
7. Set the firing rate to MAXIMUM (high fire).
8. Write down the blower RPM value. It should be within 200 RPM of the value given in Figure 96.
9. If any of the values are outside the ranges listed in the previous steps, contact the factory for technical assistance.

**NOTICE** Minimum and maximum blower speeds can be adjusted within limits, but changing speeds will affect AFUE ratings.

## Check flue gas temperature

1. Set the boiler to high fire. Then adjust the Control display to view flue gas temperature and boiler return temperature.
2. The flue gas temperature should be no more than 50°F higher than the boiler return temperature.
3. If the flue temperature is higher than this, shut down the boiler, allow to cool, and follow the procedure starting on [page 111](#) to clean the heat exchanger.

**Figure 96** Firing rates and corresponding blower speeds (low fire, ignition, and high fire) — for altitudes up to 5,500 feet and high altitude (above 5,500 feet).

Model	EVG 220				EVG 299/300			EVG 399		
	Fuel Type	%	RPM	Btu/Hr Note 1	%	RPM	Btu/Hr Note 1	%	RPM	Btu/Hr Note 1
<b>Low fire</b>										
Factory setting	NG	10%	1,115	22,000	10%	1,175	29,900	10%	1,210	39,900
	LP	10%	1,250	22,000	10%	1,145	29,900	10%	1,150	39,900
High altitude	NG	11% to 19%	1,190 to 1,587	22,000	11% to 18%	1,235 to 1,601	29,900	11% to 18%	1,297 to 1,695	39,900
	LP	11% to 18%	1,315 to 1,632	22,000	11% to 16%	1,192 to 1,469	29,900	11% to 18%	1,247 to 1,645	39,900
<b>Ignition ("Medium" setting in manual test mode)</b>										
Factory setting	NG	43%	3,000	94,550	38%	2,800	113,600	39%	3,150	156,300
	LP	43%	2,850	94,550	38%	2,640	113,600	39%	3,000	156,300
High altitude	NG	57%	3,830	will vary	51%	3,540	will vary	52%	4,030	will vary
	LP	57%	3,620	will vary	50%	3,330	will vary	52%	3,840	will vary
<b>High fire (adjust if desired to match maximum system load — High fire % rate = Max heat load / Boiler output) (adjusting speed will affect boiler AFUE rating)</b>										
Factory setting	NG	96%	6,030	211,200	96%	6,100	287,040	96%	6,930	383,040
	LP	96%	5,660	211,200	96%	5,800	287,040	96%	6,600	383,040
Maximum setting	NG	100%	6,260	220,000	100%	6,325	299,000	100%	7,200	399,000
	LP	100%	5,875	220,000	100%	6,020	299,000	100%	6,850	399,000

Note 1 — The boiler will automatically derate the Btu values listed in this table by 4% per 1,000 feet above sea level.

Low fire high altitude rpm's change starting at 2,500 feet. The rpm's will increase from the low value to the high value (11,000 feet) in a linear fashion.

Ignition high altitude rpm's change at 5,500 feet.



# Annual startup *(continued)*

## Manual Test Mode for Single and Multiple Boilers

### Single Boiler

1. Navigate to Manual Test Mode screen under DIAGNOSTICS menu.
2. Generate a call for heat and wait until the burner is lit, if not yet in operation.
3. Press ENTER and select the desired FORCE RATE. Rate will be forced to setting for 10 minutes.

### Multiple Boiler Running

1. Generate a call for heat on a Network Priority or a Local Priority
  - a. Local Priority—allows Force Rate only on the boiler with the call for heat. Follow Single Boiler procedure, above.
  - b. Network Priority—allows Force Rate on any boiler in the network. Follow procedure outline below in steps 2-5.
2. On the Master boiler, navigate to Manual Test Mode screen under DIAGNOSTICS menu. Select desired boiler to be tested.
3. The Manual Test Mode screen will automatically appear on the boiler you selected. On the selected boiler's control, press ENTER and select the desired FORCE RATE (HIGH, MED, OR LOW).

- CAUTION** When forcing a rate on a Network Priority call, only boilers running Local Priority calls will remain on. All other boilers on the network will not fire until the Manual Test has ended. Ensure critical applications remain heated. Long periods of low heating can cause property damage.
4. The selected boiler will run at the forced rate until it is either returned to AUTO, the user selects “End Manual Test” on the Master's Manual Test Mode screen, or after 30 minutes of inactivity on the Master control.
  5. To test the next boiler, return to the master and select the next desired boiler to test.

## Reinstall jacket door after servicing

### WARNING

Reinstall boiler jacket front door after start-up or servicing. The boiler front door must be securely fastened to the boiler to prevent boiler from drawing air from inside the boiler room. This is particularly important if the boiler is located in the same room as other appliances.

Failure to keep the door securely sealed and fastened could result in severe personal injury or death.

## Review with owner

1. Review the User's Information Manual with the owner.
2. Emphasize the need to perform the maintenance schedule specified in the User's Information Manual (and in this manual as well).
3. Remind the owner of the need to call a licensed contractor should the boiler or system exhibit any unusual behavior.
4. Remind the owner to follow the proper shut down procedure and to schedule an annual startup at the beginning of the next heating season.

## Check boiler relief valve

1. Inspect the relief valve and lift the lever to verify flow as in the following warnings, excerpted from a relief valve manufacturer's warning label. Before operating any relief valve, ensure that it is piped with its discharge in a safe area to avoid severe scald potential.
2. Read [page 41](#) before proceeding further.
3. Follow instructions below or perform procedures per relief valve manufacturer's printed instructions.

### WARNING

Safety relief valves should be re-inspected AT LEAST ONCE EVERY THREE YEARS, by a licensed plumbing contractor or authorized inspection agency, to ensure that the product has not been affected by corrosive water conditions and to ensure that the valve and discharge line have not been altered or tampered with illegally. Certain naturally occurring conditions may corrode the valve or its components over time, rendering the valve inoperative. Such conditions are not detectable unless the valve and its components are physically removed and inspected. This inspection must only be conducted by a plumbing contractor or authorized inspection agency — not by the owner. Failure to reinspect the boiler relief valve as directed could result in unsafe pressure buildup, which can result in severe personal injury, death or substantial property damage.

### WARNING

Following installation, the valve lever must be operated AT LEAST ONCE A YEAR to ensure that waterways are clear. Certain naturally occurring mineral deposits may adhere to the valve, rendering it inoperative. When manually operating the lever, water will discharge and precautions must be taken to avoid contact with hot water and to avoid water damage. Before operating lever, check to see that a discharge line is connected to this valve directing the flow of hot water from the valve to a proper place of disposal. Otherwise severe personal injury or property damage may result. If no water flows, valve is inoperative. Shut down boiler until a new relief valve has been installed.

4. After following the above warning directions, if the relief valve weeps or will not seat properly, replace the relief valve. Ensure that the reason for relief valve weeping is the valve and not over-pressurization of the system due to expansion tank waterlogging or under-sizing.



# Troubleshooting

## VERIFY PROPER OPERATION AFTER SERVICING

Before calling for troubleshooting assistance, fill in the “Evergreen<sup>®</sup> Gas Data Collection Sheet” (page 132). Record the boiler size and CP number (located on the outside left jacket above the rating label).

## BEFORE TROUBLESHOOTING —

**⚠ WARNING** Failure to adhere to these guidelines can result in severe personal injury, death or substantial property damage.

### ELECTRICAL SHOCK HAZARD

The boiler ON/OFF switch does not turn off all power to the boiler. **TURN OFF ALL POWER TO THE BOILER WHEN SERVICING.** Internal wiring is still powered when the switch is off.

### DO NOT JUMPER DEVICES

Never jumper (bypass) any device except for momentary testing.

### REINSTALL JACKET DOOR

The boiler door must be securely fastened to the boiler to prevent boiler from drawing air from inside the boiler room. This is particularly important if the boiler is located in the same room as other appliances. Failure to keep the door securely fastened could result in severe personal injury or death.

### BEFORE SERVICING or MAKING CONNECTIONS —

**ALWAYS TURN POWER OFF TO THE BOILER TO PREVENT ELECTRICAL SURGES, WHICH CAN DAMAGE BOILER COMPONENTS.**

### LABEL WIRES BEFORE REMOVING

**⚠ CAUTION** Label all wires prior to disconnection when servicing controls. Wiring errors can cause improper and dangerous operation.

1. See below for tools and kits recommended for troubleshooting Evergreen<sup>®</sup> boilers.
2. Check for 120 VAC (minimum 102 VAC to maximum 132 VAC) to boiler.
3. Check the Control’s last three lockout histories. (Navigate to the DIAGNOSTICS menus.)
  - a. See [Figure 74, page 75](#) for navigation instructions and [Figure 80, page 80](#) for the complete Diagnostics menus.
  - b. In the DIAGNOSTICS menu, scroll down to PAST ERRORS and press the enter key.
  - c. Record the first three data records and then highlight the history record you want to view. See [page 132](#), (Data collection sheet).
  - d. Follow information at the bottom of the screen to navigate through your lockout histories.

Tool	Purpose
#2 Phillips screwdriver	Multiple uses
Flat blade screwdriver	To assemble the condensate trap
3 mm Allen wrench	For removing igniter and flame sense screws
10 mm wrench	For removing heat exchanger cover plate
T20 Torx	For removing burner access cover
8 mm socket with 8” extension	For removing blower
5/16” socket or nut driver	For removing air baffle and burner access panel
Multimeter	Measurements on sensors and electrical components
Manometer (Inclined or digital)	Measure the INLET gas pressure to the boiler
Combustion analyzer (Digital preferred)	Combustion testing and boiler adjustments
Contact thermometer	Checking surface temperatures of heat exchanger and pipes
Maintenance kit	ALWAYS have this kit on hand when performing maintenance in case replacement is required.

### Check the following:

1. Make sure thermostat is calling for heat and contacts (including appropriate zone controls) are closed. Check for 24 VAC between thermostat wire nuts and ground.
2. Make sure all external limit controls are either installed (and closed) or temporarily jumpered for testing.
3. Make sure that connectors to Control are securely plugged in at module and originating control.
4. Gas pressures:
  - Maximum: 14” (356 mm) w.c. with no flow (gas valve lockup pressure).
  - Minimum: must be no less than the minimum values given on [page 18](#) while operating on High fire.



# Troubleshooting *(continued)*

## Check Control fuses

**⚠ WARNING** ALWAYS check control fuses before replacing control or any major components (blower, etc.). If one of these fuses is blown, it can prevent control or other components from operating.

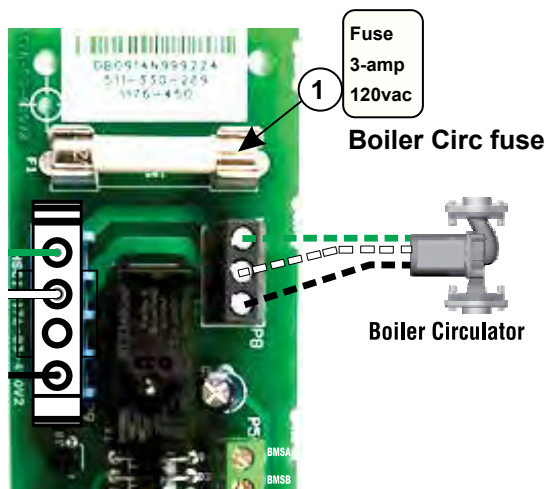
1. Turn OFF power to boiler at external line switch. Then remove the jacket door.
2. Remove four (4) screws holding control tray cover in place.
3. Remove control tray cover to access the fuses.
4. Remove and inspect the one (1) fuse (item 1, Figure 97) and remove and inspect the two (2) fuses (items 2 and 3, Figure 98) on the control module.

5. If necessary, replace one or all of the fuses:
  - a. Item 1 - Boiler Circ fuse is a 3-amp fast-blow (Littelfuse 0314003 MXP or Bussman ABC-3-R).
  - b. Item 2 - Low voltage circuit fuse is a 3-amp fast-blow (Littelfuse 0287003).
  - c. Item 3 - Line voltage circuit fuse is a 12-amp fast-blow (Littelfuse 0314012 MXP or Bussman ABC-12-R).

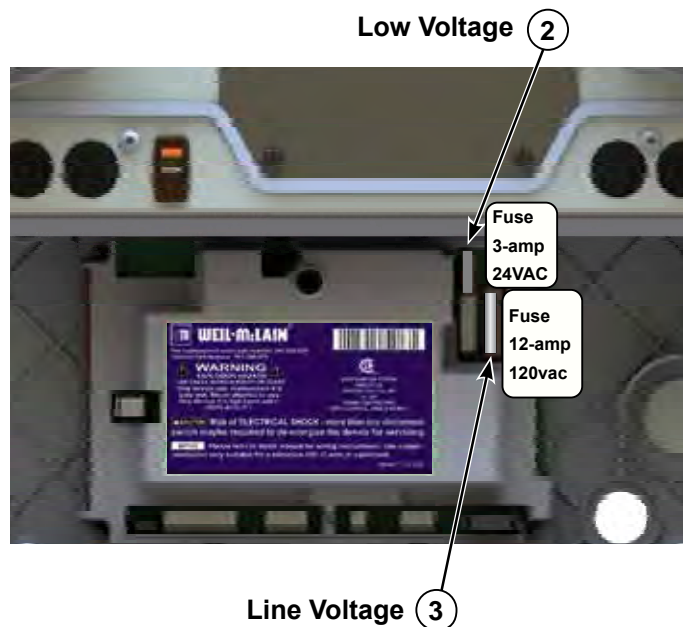
**⚠ WARNING** Do not jumper either fuse or replace with any fuse except as specified. Failure to comply could result in severe personal injury, death or substantial property damage.

6. Reinstall control tray cover.

**Figure 97** Boiler Circ fuse (control cover removed)



**Figure 98** Control module fuses (control cover removed)



## Checking temperature sensors

1. The boiler temperature sensors (flue, outdoor, return water, supply water and system temperature sensors) are all resistance-type devices. Figure 99 shows the correct value for the sensor at various temperatures. For dual sensors, the temperature difference between the sensors must be no more than 10 °F.

**Figure 99** Sensor resistance valves

Temp (°F)	Sensor ohms		Temp (°F)	Sensor ohms		Temp (°F)	Sensor ohms	
	Min	Max		Min	Max		Min	Max
32	34265	37871	90	8504	9399	150	2517	2782
40	27834	30764	100	6847	7568	160	2091	2311
50	21630	23907	110	5545	6129	170	1744	1928
60	16944	18727	120	4517	4992	180	1461	1615
70	13372	14780	130	3698	4088	190	1229	1359
80	10629	11747	140	3043	3364	200	1038	1147

2. Use the resistance values at 32°F, 60°F, 70°F and 212°F to measure the sensor resistance at known temperatures (ice point, room temperature and sea level boiling point). For ice point and boiling point, insert the sensor in water at that temperature. Use an ohmmeter to read resistance value.
3. To check whether the Control is correctly sensing temperature, you can use a resistance decade box. Connect the decade box temporarily in place of a sensor and read the corresponding temperature on the Control display. The temperature should be close to the value corresponding to the input resistance.



# Troubleshooting *(continued)*

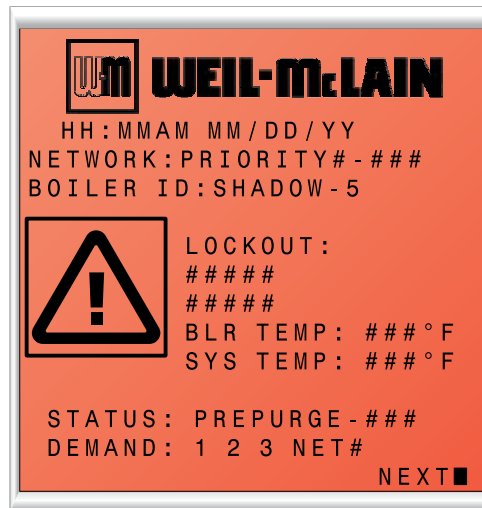
**WARNING** Make sure to determine the causes of outages. Do not leave the boiler operating without a complete diagnosis.

## Control fault indications

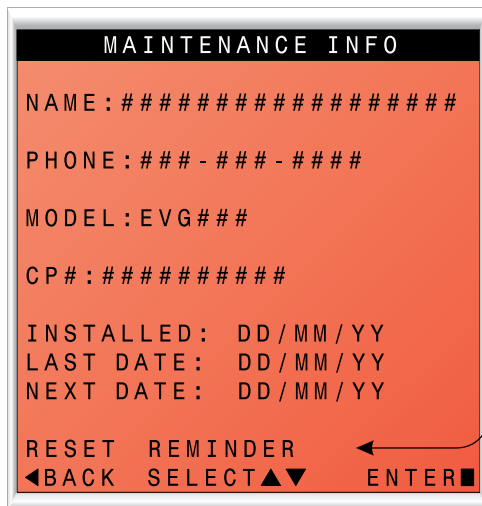
1. The control provides diagnostic information for both automatic reset conditions and manual reset conditions. See [Figure 71, page 67](#) for information available on the control display and navigation instructions for all menus.
2. Figure 100 shows the screen behavior during a fault condition. The display illustration and text below in Figure 100 shows how to reset faults from the Home Owners screen.
3. [Figure 101, page 105](#) lists conditions that will cause the control to display a constant red screen. The boiler will automatically restart if the condition self-corrects or the technician uses the control's manual reset screens to reset.

**Figure 100** Control display toggles when in lockout, with screen flashing red to gray

**NOTICE:** Screen background color alternates from RED to no backlight (gray screen).

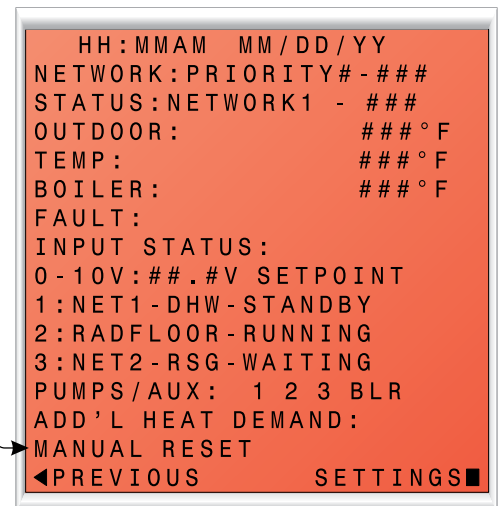


**SEE TOP LINE OF DISPLAY FOR ERROR**



Select **MANUAL RESET** to reset condition. Make sure to correct the cause of the problem if possible.

Select **RESET REMINDER** to reset the counter. The reset reminder will not occur again until the INTERVAL time has elapsed.



EV-032



# Troubleshooting *(continued)*

## RESET TO FACTORY DEFAULT

1. Selecting this will prompt the user to hold the enter button for a specified length of time. Upon completion, this will reset the control settings back to factory installed settings.
2. Reset to Factory Default can be found on the BOILER SETTINGS menu, see [Figure 75, page 76](#).

**ONCE THIS IS CHOSEN, PREVIOUS SETTINGS CANNOT BE RECOVERED. ENSURE THIS ACTION IS TRULY DESIRED BEFORE CONTINUING.**

**Figure 101** Troubleshooting suggestions for Evergreen® boilers — **Control Error Condition Log**

The Control is able to record information about the boiler’s condition at the time of the three previous faults or errors. This information is available to view in Contractor Menus under “DIAGNOSTICS” by selecting “PAST ERRORS.” The control will display the following information:

Information	Description	Action
<b>Control Fault</b>	Records the number of internal control faults.	Press the < + > key to reset this count.
<b>Ignition Retries</b>	Displays cumulative ignition attempts. It is recommended that his be reset during yearly maintenance.	Press the < + > key to reset the count or select this parameter and press enter to reset.
<b>Manual Reset Count</b>	Records number of lockouts that required a manual reset since this count was last cleared.	Press the < + > key to reset this count.
<b>Auto Reset Count</b>	Records number of lockouts that have automatically reset since this count was last cleared.	Press the < + >- key to reset this count.
<b>Lockout History 1</b>	Details of present or last recorded lockout.	Select and press the enter key for more details.
<b>Lockout History 2</b>	Details of boiler during the second oldest lockout still in memory.	Select and press the enter key for more details.
<b>Lockout History 3</b>	Details of boiler during the oldest lockout still in memory.	Select and press the enter key for more details.

**How to read the last 3 lockout histories:**

1. Scroll down to “DIAGNOSTICS” and press the enter key (Square Key in center).
2. Scroll down to “PAST ERRORS” and press the enter key (Square Key in center).
3. Scroll down to “LOCKOUT HISTORY #” and press the enter key(Square Key in center).
4. Review fault information displayed on screen.
5. Scroll up or down to highlight other choices and press the enter key to view the details of the boiler’s condition when the lockout was recorded.

**How to clear all lockout histories:**

1. While on the “PAST ERRORS” screen, hold the Left and Right arrow buttons simultaneously for 7 seconds.



# Troubleshooting *(continued)*

**Figure 102** Troubleshooting suggestions for Evergreen<sup>®</sup> boilers — **Fault displays, diagnostics and corrective actions**

Display	Condition	Diagnostics	Corrective Action(s)
<b>Nothing shown on display screen and boiler will not respond to call for heat</b>	Control is not receiving 24V power.	Check wiring for short circuit or incorrect wiring.	Correct wiring per wiring diagram including connection of transformer to the control.
		Check 3-amp low voltage fuse on control shown on <a href="#">page 103</a> .	Replace fuse with proper part found in <a href="#">Replacement parts</a> . If fuse blows again recheck wiring per diagram.
		Check transformer connection to the control per wiring diagram. Check for 24V output of transformer.	Replace transformer if it is receiving 120VAC, but not outputting 24VAC.
<b>Nothing is shown in display screen and no other boiler components are operating</b>	Control is not receiving 120V power.	Check service switch and/or circuit breaker to boiler is turned on.	Turn on service switch to power boiler.
		Is there 120 VAC at the service switch?	Troubleshoot and correct the power supply to the service switch.
		Is the Evergreen's ON/OFF POWER SWITCH located on the upper right side of the boiler, switched ON ?	Turn the Evergreen's power switch to ON.
		Check for 120 VAC at the line voltage terminal block located inside the top left electrical compartment.	Correct wiring inside the control pod using the wiring diagram in this manual.
		Inspect 12-amp fuse as shown on <a href="#">page 103</a> . Replace if necessary.	Replace the fuse with proper part found in <a href="#">Replacement parts</a> . If fuse blows again recheck wiring per diagram.
<b>Nothing is shown on display screen, but boiler is operating</b>	Occurs if the communication is lost from the control to the display.  or Display contrast needs to be adjusted.	Check for loose connections and proper pin alignment/engagement on the control's plug P9, Pump/Com board P6 + J1, and the back of the display circuit board.	Check for continuity on the wire harness from the display to the control. See <a href="#">Replacement parts</a> for proper part.
		Cycle power off and on using boiler power switch and check for operation.	Replace with new display module. See <a href="#">Replacement parts</a> for proper part.
		Look at the screen from other angles.	Power cycle the boiler, wait about 45 seconds then Press and hold the Enter button. While holding the Enter button, tap the up or down buttons to adjust the contrast level. If this does not work replace display.
<b>TEMP RISE TOO QUICKLY</b>	Occurs if supply water temperature in heat exchanger rises faster than 2° F per second during the first two minutes the burner is on.	Automatically resets after 1 minute delay or using manual reset on display.	Verify water pipe is installed correctly per instructions in this manual.
		Manual reset is necessary after 5 automatic resets have occurred during the same Priority heat demand. Reset using manual reset screen on display.	Verify proper circulator and speed for boiler size and system requirements.
			See message displayed TEMPERATURE SENSOR and follow procedure for loose connections.
<b>DISPLAY COMM Fault</b>	Occurs if display communications out for 30 seconds.	Automatically resets when communication is re-established.	Check for a loose connection at the molex plug on the control and connection on the back of the display.
<b>Hardware Fault</b>	Occurs when micro-controllers on main board have a RAM or ROM error, or communication is cut off.	Check for hardware damages.	RAM or ROM errors can be reset with the manual reset option. If problems persist, replace main board.



# Troubleshooting *(continued)*

**Figure 103** Troubleshooting suggestions for Evergreen<sup>®</sup> boilers — **Fault displays, diagnostics and corrective actions**

Display	Condition	Diagnostics	Corrective Action(s)
<b>LOW WTR CUTOFF OPEN</b>	Occurs if internal low water cutoff contacts open.	Automatic reset occurs if contacts are open at least one second, but less than 5 seconds.  Manual reset of control if contacts are open longer than 5 seconds.	Check for low water condition in system. Repair system as necessary; refer to the piping section starting on <a href="#">page 39</a> .  If low water condition does not exist, check Diagnostics — Inputs screen to view status of Low Water Cutoff. If shown as OPEN check wiring between LWCO and control. If wiring is fine, remove LWCO and Clean probe. If problem still exist, then replace the LWCO.
<b>SUPPLY 58° F &gt; RETURN</b>	Boiler Out temperature has exceeded the Boiler In temperature by more than 58° F.	Automatically resets after 30 second delay when conditions no longer exist or using manual reset on display.	Verify water pipe is installed correctly per instructions in this manual.
			Verify proper circulator and speed for boiler size and system requirements.
			See message displayed TEMPERATURE SENSOR and follow procedure for loose connections.
<b>RETURN &gt; SUPPLY</b>	Occurs if a return water temperature is greater than the corresponding supply temperature by 10° F or more.	Automatically resets when condition no longer exists.	Verify proper flow direction of the boiler circulator. Verify proper placement of system sensors for single or multiple boiler system. System sensors should be on system piping not on the boiler loop. Verify sensors are wired to correct terminal locations. System sensors may need to be located further away from the boiler loop connection to the system, if proximity to the boiler loop is causing sensors to be heated inaccurately.
<b>SUPPLY WATER TEMPERATURE TOO HIGH</b>	Occurs when the System Supply temperature goes above 200° F when the burner is running.	Automatically resets when Supply temperature goes below 200° F.	Verify proper flow direction of the boiler circulator. This circulator must be installed to push water through the system.
<b>TEMPERATURE SENSOR FAULT</b>	Occurs if a temperature sensor has electrically shorted (SHORT) or has become disconnected (OPEN).	Will automatically reset if the condition clears.	Check all the temperature readings of the boiler on the DIAGNOSTICS - TEMPERATURES menu to determine if any sensors are currently displayed as SHORT or OPEN. Compare this to the boiler temperatures recorded in the DIAGNOSTICS - ERRORS - LOCKOUT HISTORY # - TEMPERATURES during the last several lockout conditions.  Determine which sensors are suspect and measure their resistance value and compare it to the values shown in <a href="#">Figure 99, page 103</a> . If the resistance values are incorrect replace the temperature sensor. Refer to <a href="#">Replacement parts</a> for proper part number.
			Check wire harness for loose connections and pin engagement at sensor connection, chassis mount connection through control housing, and the control. Unplug connection at sensor and at control and check continuity between ends.
			If problem persists after checking items above, replace control. Refer to <a href="#">Replacement parts</a> for kit number.
	Occurs if dual temperature sensors values have spread by more than 10° F if the burner is on.	Automatically resets when sensors are within 10° F.	Follow procedure for above for SHORT and OPEN sensor conditions to properly diagnose sensor. If measured resistance values of sensors convert to temperatures separated by more than 10° F replace the sensor.
<b>FLUE TEMP TOO HIGH</b>	Occurs if flue temperature sensor exceeds 210° F (Warning) or 220° F (Lockout).	Automatic reset occurs if temperature drops below 210° F for 2½ minutes.  Manual reset is required if the temperature rises above 220° F. Reset using manual reset screen on display.	Follow procedure for above for SHORT and OPEN sensor conditions to properly diagnose sensor. In addition inspect heat exchanger combustion chamber and flueways for abnormal wear or buildup.  Inspect vent system for abnormal wear or damage.  Contact Weil-McLain Technical Support.



# Troubleshooting *(continued)*

**Figure 104** Troubleshooting suggestions for Evergreen<sup>®</sup> boilers — **Fault displays, diagnostics and corrective actions**

Display	Condition	Diagnostics	Corrective Action(s)
<b>LIMIT OPEN</b>	Occurs if manual or automatic reset limit opens.	Automatic external limit will reset 2½ minutes after external limit device closes.	Is there an external safety device connected? If yes, troubleshoot the external limit to determine and correct the cause that opened the limit. Also check for loose wiring connections.
		Manual limit fault must be reset by choosing Manual Reset on the display.	Remove the top right Control tray cover and inspect the connector. Ensure a jumper is installed across the MAN LIMIT terminals if not using a manual reset external limit. Ensure a jumper is installed across the AUTO LIMIT terminals if not using an automatic reset external limit.
<b>HIGH TEMP LIMIT</b>	Boiler temperature sensor reached High Temp Limit setting (no higher than 200° F).	Reset using manual reset screen on display.	Verify that high limit setting is at least 10° F above the <u>maximum target temperature plus the off differential</u> .
			Verify all isolation valves are open and circulators are programmed into the control properly. The boiler circulator output and System Pump/Aux. output can be configured to turn on or off with each priority. Refer to the control section starting on <u>page 63</u> to configure these properly for the system.
			Verify water pipe is installed correctly per instructions in this manual.
			Verify proper circulator sizing for boiler size and system requirements.
			See message displayed TEMPERATURE SENSOR and follow procedure for loose connections.
<b>FLAME FAULT</b>	Occurs if flame is detected when there should be no flame.	Reset using manual reset screen on display.	Burner may be operating too hot due to incorrect combustion. Inspect flame and conduct combustion test. Force boiler into high fire. Check flue gases with combustion analyzer and correct using the maintenance and startup procedure in this manual.
			Verify FLAME SIGNAL value quickly goes to zero on the DIAGNOSTICS - INPUTS screen when the gas valve closes.
			Check for flame at burner via flame current with burner off. Turn boiler off and watch flame through observation port. If flame continues after shut down replace gas valve.
<b>GAS VALVE FAULT</b>	The control has detected a problem with gas valve output circuit.	Control will do automatic retry; lockout if retry unsuccessful; retry 1 hour after lockout — restart if condition cleared, but lockout requires manual reset if condition still present.	If lockout reoccurs replace control.
<b>BLOWER FAULT</b>	Blower unable to reach required speed or does not reach 0 RPM when turned off.	Reset using manual reset screen on display; Control will check again after 1 hour and will automatically restart if condition is corrected.	Check wire harness for loose connections and pin engagement at blower connections, chassis mount connection through control housing, and control. Unplug connection at blower and at control and check continuity between ends. Blower is connected to both low voltage and line voltage harness.
			Check Diagnostics - Inputs screen with boiler in standby mode and blower not running. If BLOWER SPEED is not 0 RPM then replace blower.
			If blower does not rotate during ignition sequence check for 120V power at blower connection. If 120 VAC power at blower motor and it doesn't start replace blower. Check power at control. If 120VAC is not present at control when boiler is powered replace Control. Refer to <u>Replacement parts</u> .



# Troubleshooting *(continued)*

**Figure 105** Troubleshooting suggestions for Evergreen<sup>®</sup> boilers — **Fault displays, diagnostics and corrective actions**

Display	Condition	Diagnostics	Corrective Action(s)
<b>IGNITION FAULT</b>	Boiler went through 5 ignition attempts and never detected flame or flame sense value never reached minimum threshold for boiler model.	Automatically resets after 1 hour or can be reset by performing manual reset on boiler.	Check condensate trap for blockage allowing condensate to accumulate inside heat exchanger. Check ignition cable connection.
			Fouled, worn, bent, or faulty igniter. Fouled igniters can be cleaned for additional use with steel wool. Worn or badly fouled igniters should be replaced with the proper repair part. Igniter rods should be parallel with a 3.5 mm (0.138 in) spark gap.
			NOTICE: Thin white deposits on the igniter are typical, but brown or black deposits could be the result of flue gas recirculation. Thoroughly inspect the venting system and termination for the possibility of leakage or flue gas feedback into the air line.
			Dirty burner and/or heat exchanger will cause high back pressure and poor ignition. Follow procedure in the <a href="#">Maintenance</a> section of this manual to clean burner and heat exchanger. Visual inspection of flueways may not be sufficient to diagnose condition.
			Check combustion settings on high and low fire and adjust per setup instructions if necessary.
			Check incoming gas pressure with boiler off and at high fire. Adjust within limits on rating label.
			Verify correct boiler model and altitude is selected in control and correct elevation must be entered when operating above 2,00 feet.
			Check ignition cable resistance. Should measure 1000 Ohms (+/- 50 Ohms).
			Check for flue pipe and intake pipe restrictions or blockage.
			Check burner fasteners and gaskets.
Check venturi gaskets and proper venturi. (Propane models use different venturi's).			
<b>OUTDOOR SENSOR ERROR</b>	Outdoor temperature sensor short or OPEN.	Will automatically reset if the condition clears.	Determine which sensors are suspect and measure their resistance value and compare it to the values shown in <a href="#">Figure 99, page 103</a> . If the resistance values are incorrect replace the temperature sensor. Refer to <a href="#">Replacement parts</a> for proper part number.
		Warning only. Supply Max is targeted until ODT is restored, if used for target adjustment.	Check wire harness for loose connections and pin engagement at sensor connection, chassis mount connection through control housing, and the control. Unplug connection at sensor and at control and check continuity between ends.  If problem persists after checking items above, replace control. Refer to <a href="#">Replacement parts</a> for kit number.
<b>AIR PRESSURE Switch Open</b>	Occurs when Air Pressure connection is open.	Reset using Manual Reset screen on display. High pressure in the exhaust pipe or high vacuum in the boiler intake or cabinet has caused the air switch to open. The switch is closed in normal operating conditions.	Check boiler size selected in control against boiler rating label. Correct if necessary to select the proper boiler size.
			Check exhaust and intake pipe for restrictions or blockage.
			Check condensate drain for blockage. If condensate is unable to drain out of the boiler it can begin to block the flow of exhaust gases. Clean the condensate collection area of the base and condensate trap. Refill trap with fresh water.
			Check the P7 connection as seen on <a href="#">Figure 65, page 59</a> & <a href="#">Figure 66, page 60</a> . Check the connections on the pressure switch.
<b>Closure Switch fault</b>	Proof of Closure connections on P7 Pins 2 and 3 are open.	Soft lockout for 3½ minutes boiler retries. Each consecutive failure adds 1 minute to lockout time, up to 6½ minutes maximum.	None - Check jumper on correct pins and secure connection. Flow switch attached - Check correct pump is on, check wiring to flow switch, and check switch is closing CAD - Check voltage to damper. Check damper is opening.



# Maintenance

**▲WARNING** DO NOT SERVICE THE BOILER WITHOUT AN Evergreen® MAINTENANCE KIT AVAILABLE

The Evergreen® maintenance kit includes essential components that must be replaced when accessing or disassembling parts of the boiler.

Failure to replace damaged components and to use only the parts specifically intended for the boiler can result in severe personal injury, death or substantial property damage.

See [Figure 111, page 117](#) for part number.

## General maintenance

1. Oil motors in system requiring regular oiling.
2. See Oiled bearing circulators for motor oiling procedures.

## Oiled bearing circulators

1. Check circulators in the system. Oil any circulators requiring oil, following circulator manufacturer's instructions. Over-oiling will damage the circulator.

## Cleaning the heat exchanger WATER SIDE, when required

1. Isolate the boiler from the heating system.
2. Obtain Sentinel X400 cleaner from Weil-McLain. Follow instructions supplied with the cleaner to clean the boiler heat exchanger.

**▲WARNING** We recommend using the cleaning product available from Weil-McLain, Sentinel X400. See [Replacement parts](#) for ordering information.

Using other cleaning materials or methods could cause permanent damage to the boiler heat exchanger.

**▲WARNING** Inspect the heating system water. If there is evidence of sediment or corrosion, the boiler must be isolated from the system. The system must then be thoroughly cleaned to remove all sediment.

Isolate the cause of the system corrosion and correct the problem(s) before placing the boiler back in service.

Failure to comply could result in severe personal injury, death or substantial property damage.

## Disconnect power

**▲WARNING** Electrical shock hazard — Disconnect all electrical power to the boiler before attempting maintenance procedures. Failure to complete could result in severe personal injury, death or substantial property damage.

## Re-install boiler jacket door after startup or servicing

**▲WARNING** Reinstall boiler jacket door after start-up or servicing. The boiler front door must be securely fastened to the boiler to prevent boiler from drawing air from inside the boiler room. This is particularly important if the boiler is located in the same room as other appliances.

Inspect boiler jacket door gaskets. Gaskets must be in good condition, with no tears or gaps. Replace if necessary.

Failure to keep the door securely sealed and fastened could result in severe personal injury or death.

## Start-up and check/out

**▲WARNING** Removing and reinstalling components can change boiler behavior. After any maintenance procedure, you must prove the boiler is operating correctly. To do so, follow the complete procedure for boiler and system start-up, beginning on [page 86](#).

After placing the boiler in operation, the ignition system safety shutoff device must be tested, [page 91](#).

Failure to comply could result in severe personal injury, death or substantial property damage.



# Cleaning heat exchanger flue side

**⚠WARNING** The boiler contains ceramic fiber materials. Use care when handling these materials per instructions on page 94 of this manual. Failure to comply could result in severe personal injury.

## Tools required

1. Allen wrench, 3 mm (T-wrench preferred).
2. 8 mm socket with 8-inch extension.
3. Metric wrench or socket, 10 mm.
4. T20 Torx.
5. 5/16" socket or nut driver.
6. Torque wrench.
7. Putty knife.

## Before proceeding:

1. Shut down the boiler:
  - a. Follow “To Turn Off Gas to Appliance” instructions on boiler and Operating instructions.
  - b. Close the boiler manual gas valve.
2. Allow time for the boiler to cool to room temperature if it has been firing.
3. Remove jacket front door by removing the two (2) latches at the top of the jacket door.
4. Rotate and lift the jacket door away from the boiler to remove.
5. See Figure 106 (EVG 220 shown).
  - a. Remove the burner access panel (item 1) located on the top of the boiler jacket by removing the screws (item 3).
  - b. Remove the air baffle (item 2) and screws (item 4) from the jacket top as shown.

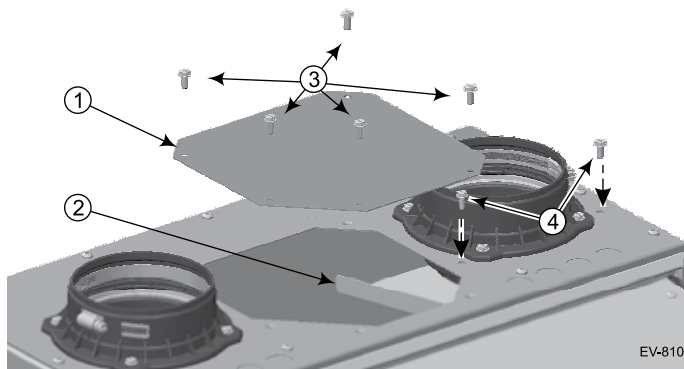
## Remove and inspect the igniter assembly

1. Carefully remove the ignition electrode assembly, following the instructions in “Remove and inspect ignition electrode assembly and wiring” on page 97.
2. Set ignition electrode assembly and new gasket aside for later re-insertion.

## Remove and inspect flame sense rod assembly

1. Carefully remove the flame sense rod assembly, following the instructions in See instructions on page 97 under “Inspect Flame Sense Rod”.
2. Set the flame sense rod with new gasket aside for later re-insertion.

**Figure 106** Remove the burner access panel and screws (1 and 3) and air baffle and screws (2 and 4) from the jacket top as shown



## Remove, inspect and clean the burner

1. See Figure 109, page 115 (EVG 220 shown).
2. Use a T20 Torx to remove the four (4) M4 screws (item 10) that secure the burner access cover (item 4) to the heat exchanger cover plate (item 6).
3. Remove the burner access cover (item 4) and the burner (item 11).

**⚠WARNING** Use caution when removing the burner to pull it directly up and out. DO NOT angle the burner as you remove it. Angling the burner could cause it to strike the refractory, damaging the refractory and causing fragments to fall into the heat exchanger. Should this happen, a heat exchanger refractory replacement kit must be installed and the heat exchanger must be thoroughly cleaned following the procedures given in this manual and the refractory replacement instructions.

4. Remove and discard the burner gasket (item 12). This gasket is graphite and may pull apart or stick to the burner on removal. Use a soft brush if necessary to remove residue. DO NOT allow debris to drop into the heat exchanger. A new gasket must be installed later when the burner is re-inserted.
5. Inspect the burner access cover seal (item 13). Discard and use a new seal during re-assembly if the seal is damaged in any way.
6. Inspect the interior of the burner. Brush and vacuum the interior if needed to remove lint or sediment. Alternative cleaning methods:
  - a. Blow air or nitrogen from the inside out.
  - b. Clean with a water spray from inside the burner.
7. Inspect the burner exterior. It must be in good condition, with no visible damage.
8. Clean the under side of the burner flange (see item 15) with a soft brush to remove any gasket fragments remaining.
9. Set the burner aside for re-insertion later.



# Cleaning heat exchanger flue side *(continued)*

## Inspect combustion chamber and refractory

1. Look into the burner opening in the heat exchanger cover plate.
2. Use a trouble light and inspection mirror to inspect the heat exchanger interior.
  - a. Make sure that there is no debris inside the heat exchanger.
  - b. Use the inspection mirror to check the condition of the burner refractory that is adhered to the bottom of the heat exchanger cover plate. It must be in good condition with no indication of damage or sagging.
  - c. Make sure there are no signs of overheating or of flue gas leakage.

**▲WARNING** If visual inspection of the heat exchanger indicates the need, follow the procedures in the following to remove the heat exchanger cover plate and fully inspect and clean the interior. Obtain replacement parts for any components that may be damaged or that show signs of leakage.

## Remove components to access the heat exchanger flue side

1. See [Figure 109, page 115](#) part A to locate components referenced in the following.
2. Remove the air silencer and disconnect gas line:
  - a. See [Figure 109, page 115](#) part A and part B.
  - b. Locate the clips connecting the air silencer (item 1) to the venturi (item 5). Gently pull clips out and away from the venturi. While holding clips out, slide silencer back and off of the venturi. Set the air silencer aside.
  - c. Disconnect the flexible gas line where it connects just below the gas valve (item 3). Lay the free end of the flexible gas line to the side.

**▲WARNING** Use two wrenches when disconnecting the flexible gas line to prevent damage to the gas valve and other gas line components.

- d. Disconnect wire harness connected to the gas valve and two wire harnesses connected to the blower.
3. Remove the blower/venturi/gas valve assembly.
    - a. See [Figure 109, page 115](#), part A.
    - b. Remove the two (2) 8 mm locknuts connecting the blower and cover plate.
    - c. Gently set blower/venturi/gas valve assembly aside. Inspect blower/cover plate gasket. If gasket appears damaged, discard and replace with a new gasket.

**▲WARNING** The burner, igniter and flame sense rod must be removed and inspected following the procedures beginning on [page 111](#).

4. Remove the heat exchanger cover plate:
  - a. See [Figure 109, page 115](#) part A, part B and part C.
  - b. Use a 10 mm wrench or socket to remove the nuts (item 9) that secure the heat exchanger cover plate (item 6) to the heat exchanger. [Six (6) nuts (EVG 220) or seven (7) nuts (EVG 299/300/399).]
  - c. Carefully lift the cover plate assembly straight up vertically until the cover plate refractory (part D, item 16) clears the heat exchanger studs.
  - d. Pull the assembly forward and out of the jacket.
  - e. Turn the cover plate assembly over and place on a flat surface.

## Remove and discard refractory and replace burner gasket

1. See [Figure 109, page 115](#) part B and C.
  - a. Use a wide-blade putty knife to gently pry the refractory from the heat exchanger cover plate. The refractory is attached with silicone adhesive and should separate with a little pressure on the putty knife.

**▲WARNING** DO NOT gouge or crack the refractory. The refractory is made of ceramic fiber materials. Read the ceramic fiber WARNING on [page 94](#) before handling or disposing of ceramic fiber materials.

- b. Carefully scrape off any adhesive residue with the putty knife, avoiding scratching or gouging the heat exchanger cover plate surface.
  - c. Wipe off any residue, clean off the work table surface and turn the cover plate over, bottom side on the work surface.
2. Remove the burner gasket (item 12) from the heat exchanger cover plate.
  3. Clean the gasket surface with a soft brush to remove any gasket residue.
  4. Lay the heat exchanger cover plate aside for re-installation later.

## Inspect and clean the heat exchanger

1. Remove and discard the heat exchanger cover plate gasket.
  - a. The Maintenance Kit includes a new gasket for use when re-installing the cover plate.
  - b. Clean off any residue on the heat exchanger cover plate gasket surface.
2. See [Figure 109, page 115](#) part D.
3. Use a strong light to visually inspect the interior of the heat exchanger. Make sure the flueways (tubes) are clear and unobstructed.
4. Use a vacuum cleaner to remove any accumulation on the heating surfaces. This includes removing any pieces of cover plate insulation assembly than may have dropped into the exchanger.

**▲WARNING** DO NOT use any solvent when cleaning the heat exchanger.



## Cleaning heat exchanger flue side *(continued)*

5. If the vacuum cleaner is unable to clean completely, wash the heating surfaces with clean, warm water, using the following procedure.
  - a. Place a shallow pan under the boiler condensate drain connection.
  - b. Loosen the condensate trap clamp (item 22) and slide the drain line off of the drain connection. (See [Figure 109, page 115](#) for reference.)
  - c. Spray water into the heat exchanger and tubes to remove sediment. Collect water in pan below.
  - d. If additional cleaning is necessary, use a pressure washer (using caution) to obtain better scrubbing action.

**⚠ WARNING** Do not attempt to use hard objects to clean out the exchanger or tubes. The heat exchanger surfaces could be damaged.

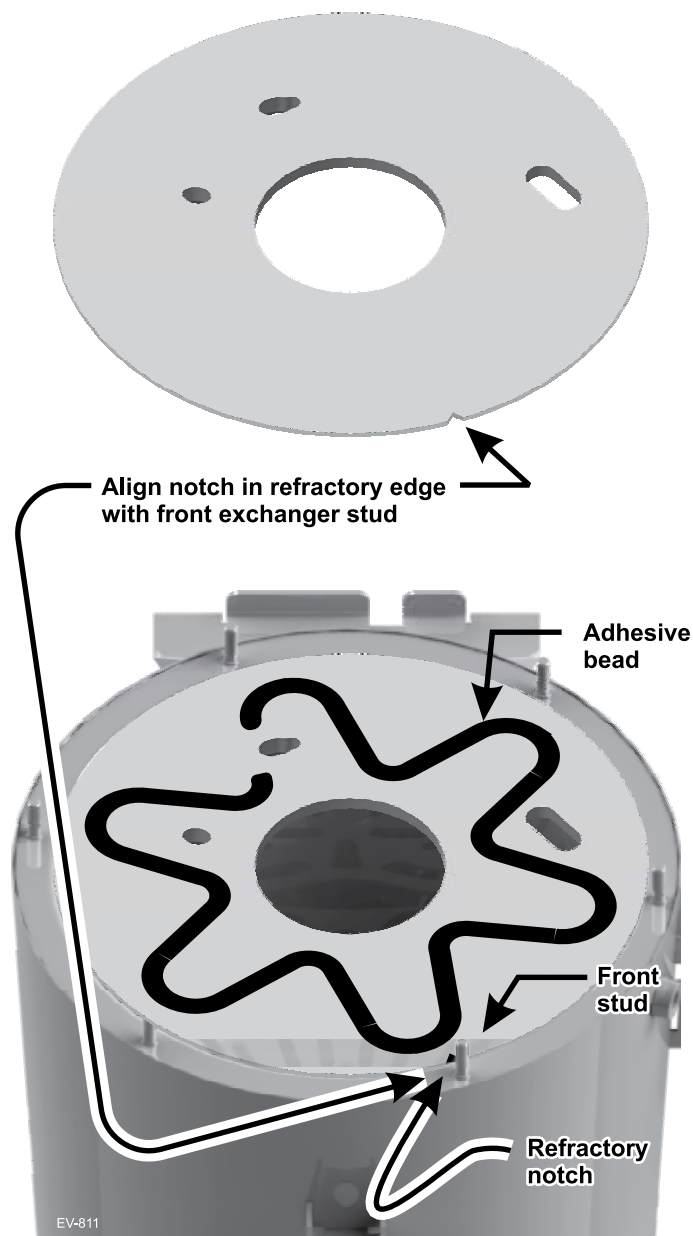
### Reinstall heat exchanger cover plate and refractory

1. See [Figure 107](#) for reference.
2. Obtain the new refractory from the Maintenance Kit.
3. Carefully place the refractory into the top of the heat exchanger as shown.
4. Align the notch in the refractory with the front heat exchanger cover plate stud (just right of center in the front).

**⚠ WARNING** DO NOT press down on the refractory. Too much force could cause the refractory to crack or be damaged.

5. Use the silicone adhesive to lay a bead of silicone in a weaving pattern as shown.
  - a. Maintain at least 1 inch clearance from edges of refractory and from openings in refractory.
  - b. Do not apply an excessive amount of adhesive. This could cause spreading or prevent good contact with the cover plate.
6. See [Figure 109, page 115](#) for reference.
7. Re-install the heat exchanger cover plate using the following procedure.
  - a. Place the heat exchanger cover plate gasket, item 17, (in Maintenance Kit) onto the heat exchanger studs.
  - b. Carefully place the heat exchanger cover plate over the heat exchanger cover plate studs.
  - c. Gently lower the cover plate until it rests on the cover plate gasket.
  - d. Reach into the cover plate burner opening and gently pull the refractory up against the cover plate to compress the adhesive for a good seal/adhesion.
  - e. Use a 10 mm wrench or socket to secure the nuts (item 9) on studs of the heat exchanger cover plate (item 6) to the heat exchanger. [Six (6) nuts (EVG 220) or seven (7) nuts (EVG 299/300/399).]
  - f. Tighten the cover plate nuts gradually, adjusting a little at a time. Use criss-cross pattern and repeat until all are tightened evenly.
  - g. Use a torque wrench to tighten the cover plate nuts, to a torque of 57 inch-pounds.

**Figure 107** Placing refractory into heat exchanger and applying silicone adhesive – EVG 220 shown





# Cleaning heat exchanger flue side *(continued)*

## Reinstall components

1. See [Figure 109, page 115](#) for reference.
2. Obtain the new burner gasket (item 12) from the Maintenance Kit and install into the heat exchanger cover plate.
3. Reinstall the burner (item 11), and burner access cover seal (item 13) on the heat exchanger cover plate (item 6).
  - a. Insert and tighten the burner access cover screws (item 10) using a T20 Torx. Tighten screws gradually, adjusting a little at a time, using a criss-cross pattern and repeating until all are tightened evenly. The screws must be secure, with
  - b. Use a torque wrench to tighten screws to a torque of 23 inch-pounds.
4. Reinstall the igniter assembly (item 7).
  - a. Insert the igniter into the cover plate opening, with the new gasket in position.
  - b. Reinstall the two (2) Allen head screws finger tight.
  - c. Use a torque wrench to tighten screws to a torque of 20 inch-pounds.
  - d. Reconnect the ignition cable and the igniter ground wire.
5. Reinstall the flame sense rod (item 8).
  - a. Carefully insert the flame sense rod into the cover plate opening, with the new gasket in position.
  - b. Use a torque wrench to tighten screws to a torque of 20 inch-pounds.
  - c. Re-attach the wire harness to the flame sense rod.
6. Reconnect the flexible gas line to the gas valve using two wrenches.
7. Reinstall the blower/venturi/gas valve assembly:
  - a. Install the two (2) 8 mm locknuts connecting the blower to the cover plate.
  - b. Use a torque wrench to tighten locknuts to a torque of 20 inch-pounds.
8. Reinstall the air inlet silencer (item 1) by pressing onto the venturi (item 5). Reinstall the air inlet silencer by gently pushing the silencer onto the venturi. If needed, gently pull apart the clips to clear venturi.
9. Reconnect the wire harnesses to the blower and gas valve.
10. Reinstall the condensate trap on the boiler condensate drain connection. (See [Figure 109, page 115](#) part E for reference.)
11. Reinstall the burner access panel and air baffle (see [Figure 106, page 111](#)). Tighten screws securely.

**⚠ WARNING** Perform a complete start-up procedure when putting the boiler back into service. See [page 92](#) and all instructions for start-up and verification. Include a soap suds leak test on all interior and exterior gas piping after starting the boiler.

After placing the boiler in operation, the ignition system safety shutoff device must be tested, [page 91](#).

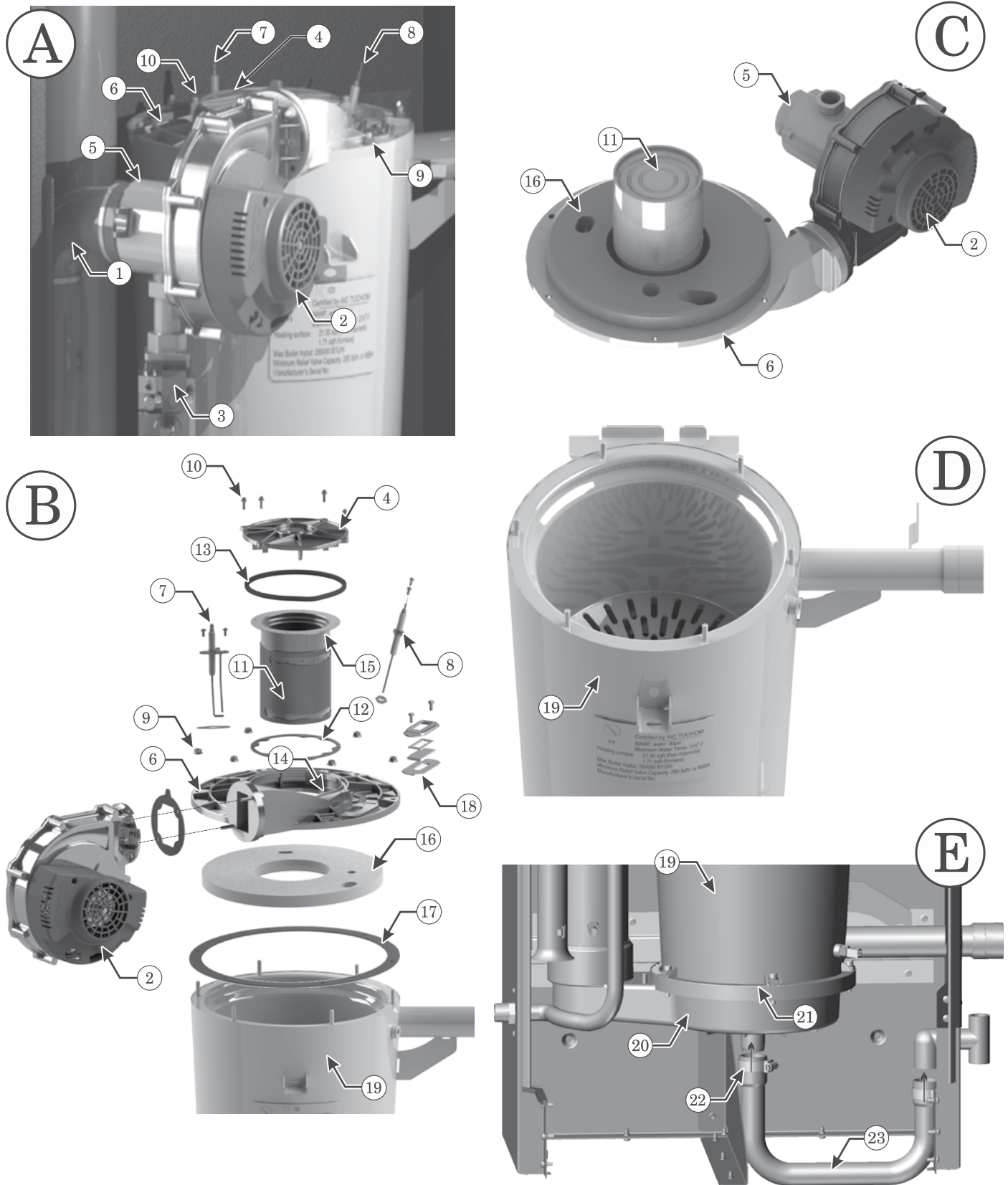
## Figure 108 Legend for [Figure 109, page 115](#)

- A** Boiler interior assembled view,
- B** Boiler interior exploded view, showing heat exchanger cover plate (item 6) blower, burner assembly, burner access cover seal (item 13), igniter, flame sense rod, and sight glass.
- C** Blower, burner, and venturi, showing combustion chamber cover plate insulation assembly (item 16)
- D** Heat exchanger interior
- E** Boiler lower interior, showing condensate dish (item 19) and condensate drain line (item 22)
- 1 Inlet air silencer
  - 2 Blower assembly
  - 3 Gas valve
  - 4 Burner access cover
  - 5 Venturi assembly
  - 6 Heat exchanger cover plate
  - 7 Igniter assembly
  - 8 Flame sense rod
  - 9 Heat exchanger cover plate retainer nuts (6) - EVG 220, and (7) - EVG 299/300/399.
  - 10** Burner cover retainer screws, M4 Phillips with captive washers
  - 11 Burner
  - 12 Burner gasket
  - 13 Burner access cover seal
  - 14 Burner gasket sealing surface
  - 15 Burner sealing surface (lower surface of burner flange)
  - 16 Combustion chamber refractory (adhered to combustion chamber cover plate with silicone adhesive)
  - 17 Heat exchanger cover plate gasket
  - 18 Sight glass assembly
  - 19 Heat exchanger outer shell
  - 20 Condensate dish
  - 21 Condensate dish joint
  - 22 Condensate drain line clamp
  - 23 Condensate drain line



# Cleaning heat exchanger flue side *(continued)*

Figure 109 Accessing the burner or heat exchanger (see Legend on page 114), (Evergreen® 220 shown).





# Replacement parts

**⚠ WARNING** DO NOT SERVICE THE BOILER WITHOUT A Evergreen® MAINTENANCE KIT AVAILABLE

The Evergreen® maintenance kit includes components that may have to be replaced when accessing or disassembling parts of the boiler. Failure to replace damaged components and to use only the parts specifically intended for the boiler can result in severe personal injury, death or substantial property damage. See [Figure 111, page 117](#) for part number.

## REPLACEMENT PART NUMBERS

Weil-McLain part numbers are found in this manual and in *Weil-McLain Boilers and Controls Repair Parts Lists*.

## WHEN OPERATING THE BOILER ON PROPANE GAS

**⚠ WARNING** ALL Evergreen® boilers must be converted in order to operate with propane gas.

Figure 110 Propane conversion kits

Boiler model	Kit part number	Installation instructions
EVG 220	540-202-849	See page 12
EVG 299/300	<a href="#">540-202-841</a>	See page 12
EVG 399	<a href="#">540-202-842</a>	See page 12

**⚠ WARNING** Failure to adhere to these guidelines can result in severe personal injury, death or substantial property damage.

## OBTAIN PARTS ONLY THROUGH WEIL-McLAIN

Replacement parts must be purchased through a local Weil-McLain distributor. When ordering, specify boiler model and size and include description and part number of replacement part. Results from using modified or other manufactured parts will not be covered by warranty and may damage boiler or impair operation.

## THE BOILER CONTAINS CERAMIC FIBER MATERIALS

The boiler contains ceramic fiber materials. Use care when handling these materials per instructions on [page 94](#) of this manual. Failure to comply could result in severe personal injury.

## REINSTALL JACKET DOOR

Inspect boiler jacket door gaskets and reinstall boiler jacket front door after start or servicing. The boiler door must be securely fastened to the boiler to prevent boiler from drawing air from inside the boiler room. This is particularly important if the boiler is located in the same room as other appliances. Failure to keep the door securely fastened could result in severe personal injury or death.

## BEFORE SERVICING or MAKING CONNECTIONS —

**ALWAYS TURN POWER OFF TO THE BOILER TO PREVENT ELECTRICAL SURGES, WHICH CAN DAMAGE BOILER COMPONENTS.**

## LABEL WIRES BEFORE REMOVING

**⚠ CAUTION** Label all wires prior to disconnection when servicing controls. Wiring errors can cause improper and dangerous operation.



# Replacement parts *(continued)*

**Figure 111** Miscellaneous parts and kits

Description	Part Number	Description	Part Number
Antifreeze, Sentinel X500 (1 gal) . . . . .	592-900-029	Sidewall separate pipes vent/air termination kits (includes two cover plates) Kit for 3" or 4" PVC vent and air pipes . . . . .	383-500-100
Antifreeze, Sentinel X500 (5 gal) . . . . .	592-900-006		
Corrosion inhibitor, Sentinel X100 . . . . .	592-900-002		
Sentinel X100 Quick Test Kit. . . . .	592-900-005		
Cleaner, Sentinel X400 . . . . .	592-900-003	PVC concentric vent kit — horizontal or vertical (includes components for concentric assembly) Kit for 3" PVC vent and air pipes. . . . .	383-500-350
<b>Evergreen®</b> Inspection kit — igniter gasket, flame sense gasket, burner gasket, burner access cover seal, and hardware	383-900-097	Kit for 4" PVC vent and air pipes. . . . .	383-900-075
	<b>Evergreen®</b> 220 maintenance kit — flame sense rod, flame sense gasket, igniter, igniter gasket, venturi gasket, cover plate gasket, venturi-gas valve o-ring, refractory, silicone, inhibitor test kit, burner access cover seal, and hardware	383-900-071	IPEX PVC concentric vent kit — available from IPEX Kit for 3" PVC vent and air pipes. . . . .
383-900-072		196106(L=32")	
<b>Evergreen®</b> 299/300 maintenance kit — flame sense rod, flame sense gasket, igniter, igniter gasket, venturi gasket, cover plate gasket, venturi-gas valve o-ring, refractory, silicone, inhibitor test kit, burner access cover seal, and hardware	383-900-072	Kit for 4" PVC vent and air pipes. . . . .	196116(L=44")
	383-900-088	Bird screens (2 required) For 3" PVC vent and air pipes . . . . .	196021
<b>Evergreen®</b> 399 maintenance kit — flame sense rod, flame sense gasket, igniter, igniter gasket, venturi gasket, cover plate gasket, venturi-gas valve o-ring, refractory, silicone, inhibitor test kit, burner access cover seal, and hardware	383-900-088		For 4" PVC vent and air pipes . . . . .
	Wall-mount kit — wall mount bracket and hardware	383-900-074	
Condensate drain tube - EVG 220	560-907-767	M&G Simpson-Duravent PolyPro VERTICAL concentric vent/air kit; — available from vent manufacturer 3" polypropylene pipe (Black) . . . . .	3PPS-VKL
Condensate drain tube - EVG 299/300/399	560-907-768		(Terra Cotta) . . . . .
Low water cut-off w/test button, Kit	383-500-643	4" polypropylene pipe (Black) . . . . .	4PPS-VKL
Relief Valve (80 psi) and P&T Gauge Kit	383-900-082	(Terra Cotta) . . . . .	4PPS-VK-TCL
	383-500-631		
Condensate neutralizer kit	383-500-631	PP Appliance Adapters; — available from vent manufacturer 4" M&G Simpson-Duravent . . . . .	4PPS-04PVC-4PPF
Direct Exhaust Kit (Includes mounting plates for intake and exhaust for inside and outside, vent screen 3 & 4 Inch, Template vent/air termination hole, and mounting hardware)	383-500-769	4" Centrotherm INNOFLUE. . . . .	ISAAL040Y
	Weil-McLain sidewall vent/air cap termination kit for PVC vent and air pipes (Includes W-M sidewall vent/air termination cap, inside and outside cover plates, and mounting hardware)	383-500-397	Centrotherm INNOFLUE VERTICAL concentric vent/air kit; — available from vent manufacturer 3" polypropylene pipe . . . . .
383-500-398		4" polypropylene pipe . . . . .	
(EVG 220) – 3" Kit	383-500-397	System Immersion Temperature Sensor (2 required)	511-724-299
(EVG 220, 299, 300 & 399) – 4" Kit	383-500-398	Protonode Conversion Kit –Bacnet	383-600-322

Go to [www.weil-mclain.com](http://www.weil-mclain.com) to locate Weil-McLain distributors



# Replacement parts *(continued)*

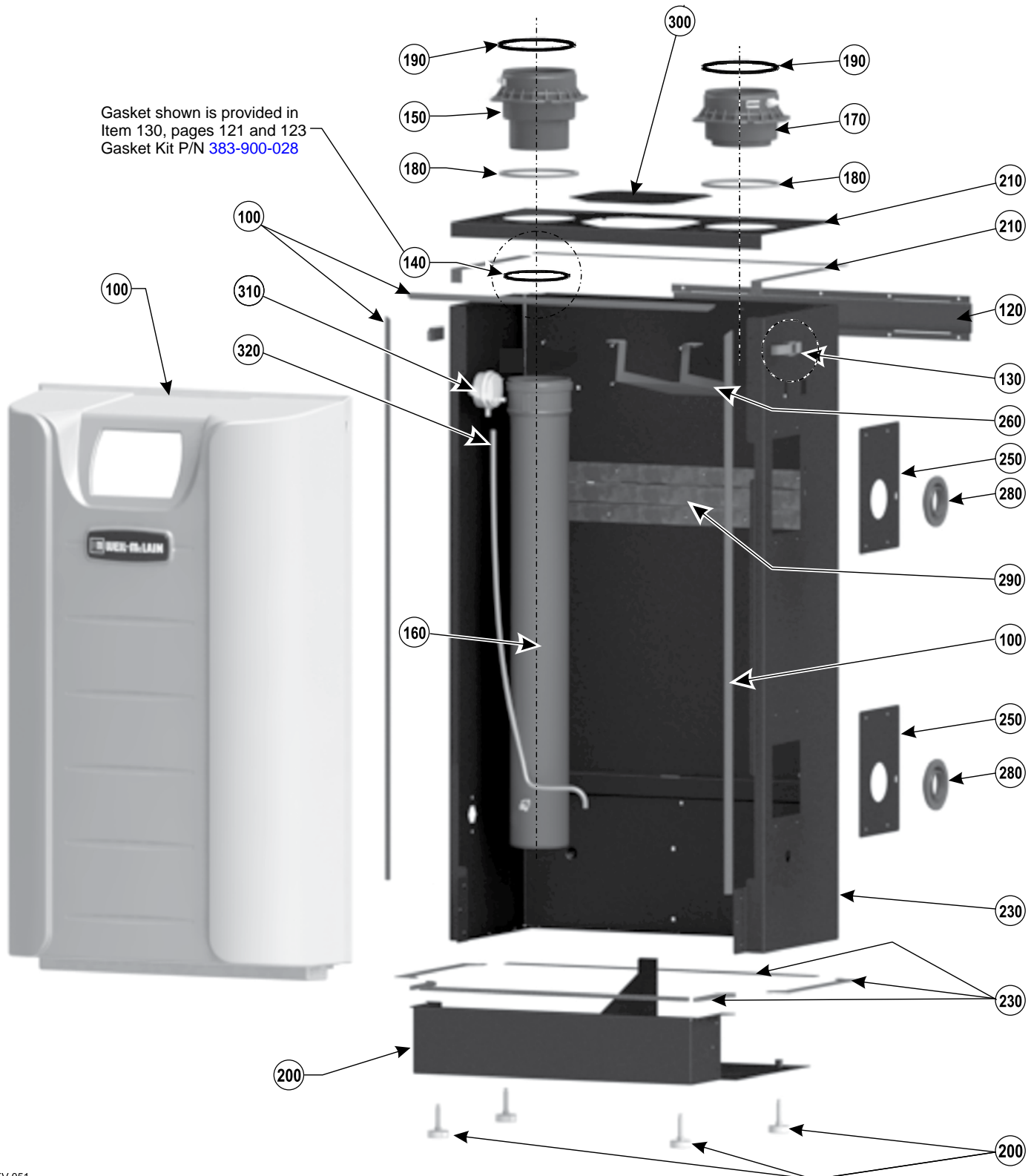
**Figure 112** Jacket parts — Evergreen<sup>®</sup> 220/299/300/399 (see [Figure 113, page 119](#) for illustration)

Item	Name	Description / contents	Part Number
100	Front door	(Includes W-M badge and door gaskets)	383-900-171
120	Wall-mount bracket (jacket side)	(Includes screws)	<a href="#">383-900-086</a>
130	Door latch (2 required)	(Includes rivets)	<a href="#">383-700-122</a>
140	Gasket kit	(Includes flue pipe gaskets and condensate dish gasket)	See P.120 for 220 see P.122 for 299/300/399
150	Flue pipe adapter	Top flue adapter with internal gasket	<a href="#">383-900-014</a>
160	Boiler flue pipe	Internal flue pipe and gasket	<a href="#">383-900-015</a>
170	Air inlet adapter	Top air inlet adapter with internal gasket	<a href="#">383-900-013</a>
180	Gasket - pipe adapter to cabinet	Gasket - flue adapter to cabinet	<a href="#">383-900-058</a>
190	Gasket - pipe adapter to system pipe	Gasket fits inner diameter of top adapter	<a href="#">590-318-106</a>
200	Jacket panel bottom	(Includes bottom gasket, leveling legs and screws)	<a href="#">383-900-042</a>
210	Jacket panel top	(Includes top gasket and screws)	<a href="#">383-900-043</a>
230	Jacket panel back	(Includes brackets, gaskets, door latches and screws)	<a href="#">383-900-044</a>
250	Bracket piping (2 required)	(Includes screws)	<a href="#">383-900-085</a>
260	Air baffle	(Includes screws)	<a href="#">383-900-084</a>
280	Grommet sealing (2 required)	Sealing water pipes to cabinet	<a href="#">562-248-762</a>
290	Bracket mounting heat exchanger	(Includes screws)	<a href="#">383-900-087</a>
300	Panel - burner access	(Includes hardware)	<a href="#">383-900-041</a>
310	Pressure switch	Set point 3.25 W.C.	<a href="#">383-900-080</a>
320	Tube - pressure switch		<a href="#">590-300-056</a>



# Replacement parts *(continued)*

**Figure 113** Jacket assembly — Evergreen<sup>®</sup> 220/299/300/399 (see Figure 112, page 118 for part numbers)



EV-051



# Replacement parts *(continued)*

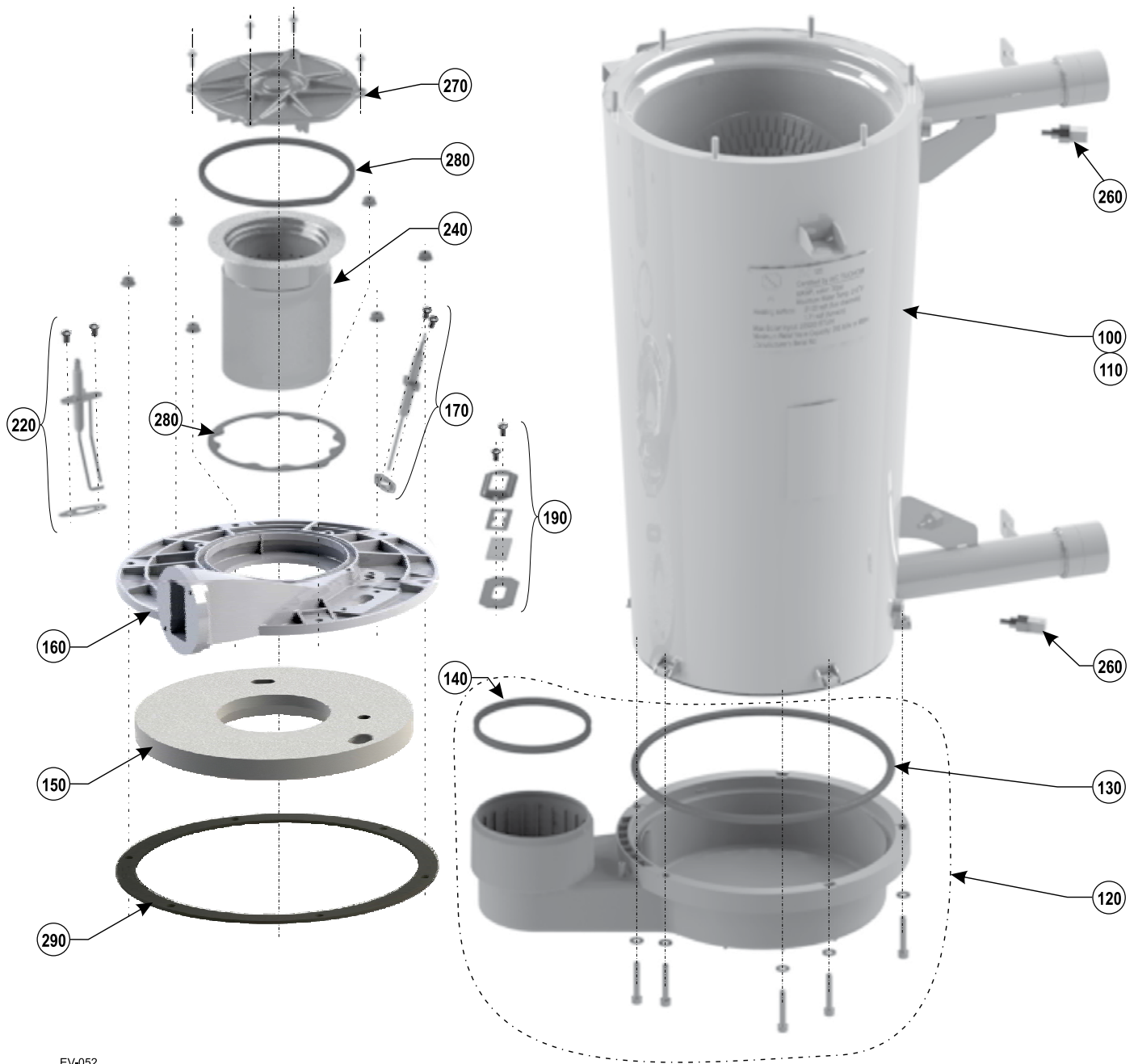
**Figure 114** Heat exchanger parts Evergreen<sup>®</sup> 220 (see [Figure 115, page 121](#) for illustration)

Item	Name	Description / contents	Part Number
100	Heat exchanger, gaskets and hardware	(Includes items 130 and 150)	<a href="#">383-900-025</a>
110	Heat exchanger, condensate dish, cover plate, burner, igniter, sight glass, refractory, water sensors, gaskets, silicone, and hardware	(Includes items 120 through 280)	<a href="#">383-900-069</a>
120	Condensate dish, gaskets, and hardware	(Includes item 130)	<a href="#">383-900-012</a>
130	Gasket to seal heat exchanger to condensate dish	(Includes flue pipe gaskets)	<a href="#">383-900-028</a>
150	Refractory insulation & silicone sealant, igniter gasket, flame rod gasket and burner gasket		<a href="#">383-900-032</a>
160	Heat exchanger cover plate, refractory, silicone, gaskets and hardware	(Includes items 150, 190, and 270)	<a href="#">383-900-016</a>
170	Flame sense rod kit	(Includes flame sense rod, gasket and screws)	<a href="#">383-900-094</a>
190	Sight glass kit	(Includes bracket, glass, gaskets, and hardware)	<a href="#">383-900-099</a>
220	Igniter kit	(Includes igniter, gasket and screws)	<a href="#">383-900-033</a>
240	Burner kit	(Includes item 280, burner, gaskets and screws)	<a href="#">383-900-022</a>
260	Heat exchanger water temperature sensor (2 required)	(One sensor for either boiler inlet or outlet water temperature)	<a href="#">511-724-296</a>
270	Burner access cover, seal and hardware	(Includes item 280)	<a href="#">383-900-019</a>
280	Burner access cover seal, burner gasket and hardware		<a href="#">383-900-010</a>



# Replacement parts *(continued)*

Figure 115 Evergreen® 220 heat exchanger assembly (see Figure 114, page 120 for part numbers)



EV-052



# Replacement parts *(continued)*

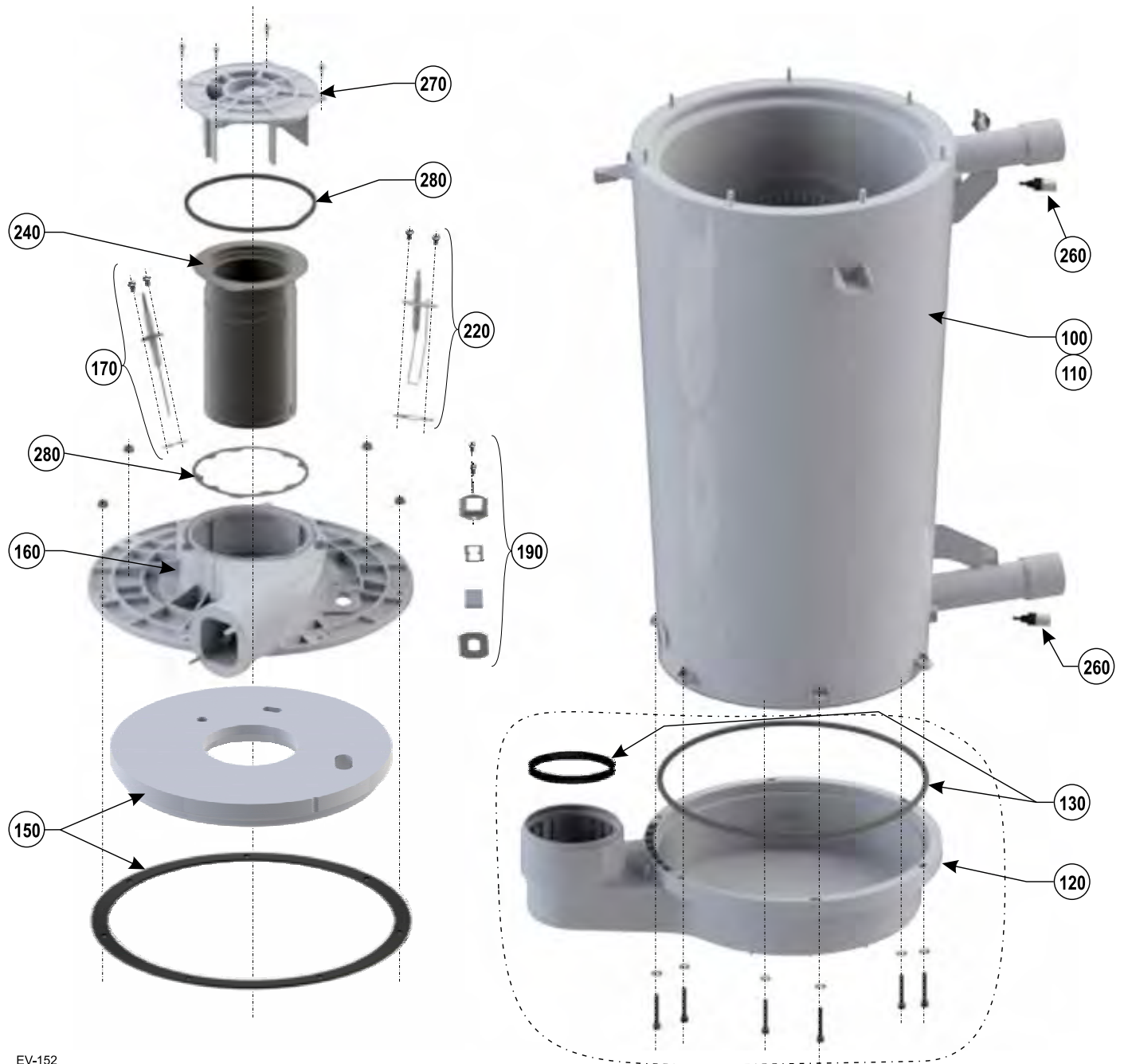
**Figure 116** Heat exchanger parts Evergreen<sup>®</sup> 299/300/399 (see [Figure 117, page 123](#) for illustration)

Item	Name	Description / contents	Part Number	Model 299/300	Model 399
100	Heat exchanger, gaskets and hardware	(Includes items 130, and 150)	383-900-024	●	—
			383-900-023	—	●
110	Heat exchanger, condensate dish, cover plate, burner, igniter, sight glass, refractory, water sensors, gaskets, silicone, and hardware	(Includes items 120 through 280)	383-900-068	●	—
			383-900-067	—	●
120	Condensate dish, gaskets, and hardware	(Includes item 130)	383-900-011	●	●
130	Gasket to seal heat exchanger to condensate dish	(Includes flue pipe gaskets)	383-900-030	●	●
150	Refractory insulation & silicone sealant, igniter gasket, flame rod gasket and burner gasket		383-900-031	●	—
			383-900-096	—	●
160	Heat exchanger cover plate, refractory, silicone, gaskets, and hardware	(Includes items 150, 190, and 270)	383-900-017	●	—
			383-900-095	—	●
170	Flame sense rod kit	(Includes flame sense rod, gasket and screws)	383-900-094	●	●
190	Sight glass kit	(Includes bracket, glass, gaskets, and hardware)	383-900-099	●	●
220	Igniter kit	(Includes igniter, gasket and screws)	383-900-033	●	●
240	Burner kit	(Includes item 280, burner, gaskets and screws)	383-900-021	●	—
			383-900-020	—	●
260	Heat exchanger water temperature sensor (2 Required)	(one sensor for either boiler inlet or outlet water temperature)	511-724-296	●	●
270	Burner access cover, gaskets and hardware	(Includes item 280)	383-900-018	●	●
280	Burner access cover seal, burner gasket and hardware		383-900-010	●	●



# Replacement parts *(continued)*

Figure 117 Evergreen® 299/300/399 heat exchanger assembly (see Figure 116, page 122 for part numbers)



EV-152



# Replacement parts *(continued)*

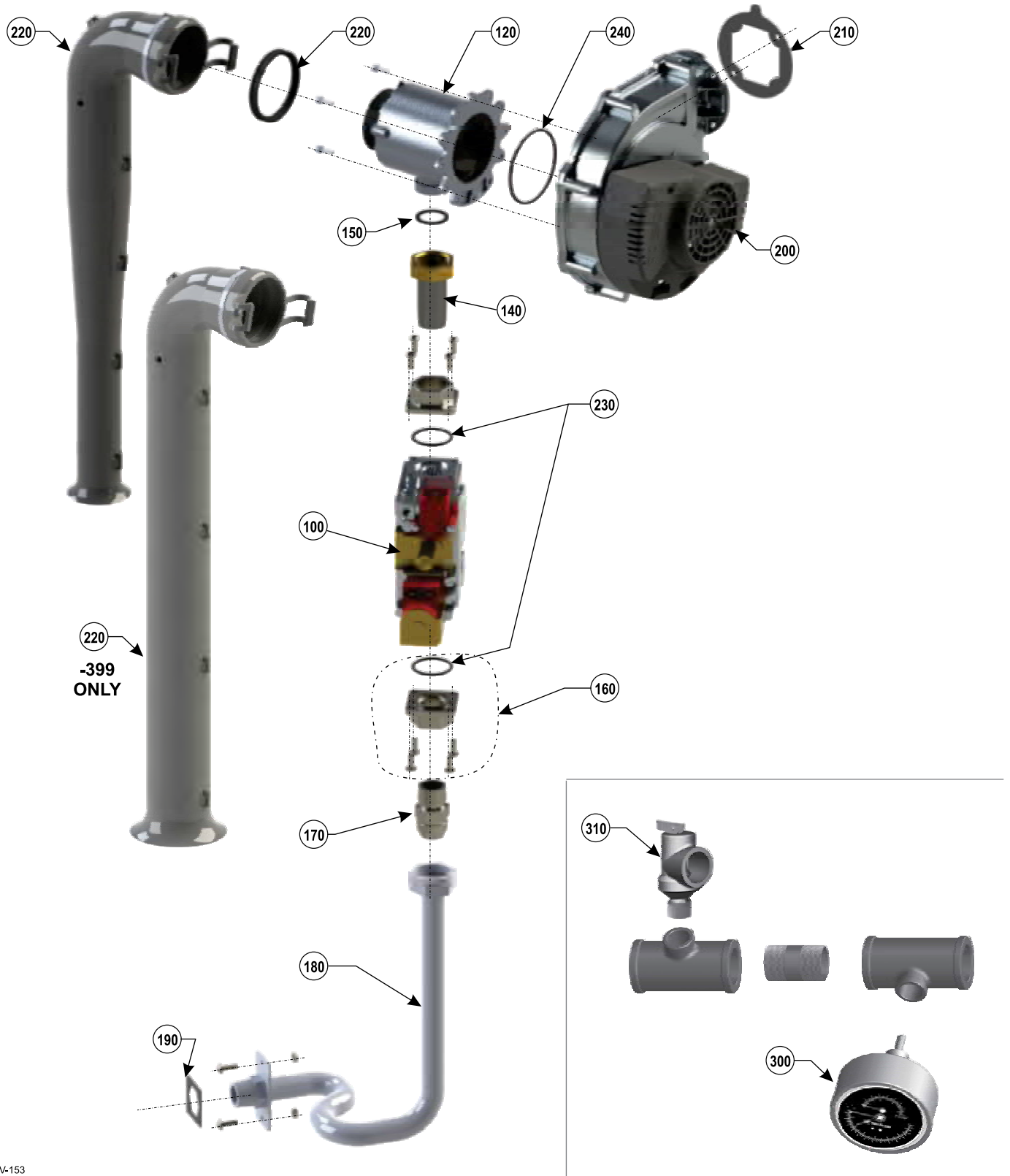
**Figure 118** Piping components for Evergreen<sup>®</sup> 220/299/300/399 (see [Figure 119, page 125](#) for illustration)

Item	Name	Description / contents	Part Number	Model 220	Model 299/300	Model 399	
100	Gas valve	Gas valve, gasket, and o-ring	<a href="#">383-900-027</a>	●	●	—	
			<a href="#">383-900-061</a>	—	—	●	
120	Venturi	Natural gas (Includes 150 and 240)	<a href="#">383-900-054</a>	●	—	—	
			<a href="#">383-900-055</a>	—	●	—	
			<a href="#">383-900-056</a>	—	—	●	
		Liquefied Petroleum (Propane) Gas (Includes 150 and 240)	<a href="#">540-202-849</a>	●	—	—	
			<a href="#">540-202-841</a>	—	●	—	
			<a href="#">540-202-842</a>	—	—	●	
140	Adapter gas pipe 3/4" NPT	Gas pipe adapter between gas valve and venturi	<a href="#">562-302-584</a>	●	●	●	
150	Gas pipe gasket	For sealing between adapter and venturi	<a href="#">562-248-765</a>	●	●	●	
160	Gas valve adapter block	Threaded block, o-ring and screws (2 required)	<a href="#">383-900-026</a>	●	●	●	
170	Gas flex line adapter	Connection between gas valve and gas line	<a href="#">562-302-583</a>	●	●	●	
180	Gas line	Gas line between gas valve and cabinet	<a href="#">560-907-766</a>	●	●	●	
190	Gas line gasket	Gas line seal to cabinet	<a href="#">590-318-085</a>	●	●	●	
200	Blower	Blower	Complete Blower	<a href="#">383-900-039</a>	●	●	●
210	Blower gasket	Blower to cover plate seal	<a href="#">383-900-036</a>	●	●	●	
220	Inlet air silencer	Silencer with gasket	<a href="#">383-900-034</a>	●	●	—	
			<a href="#">383-900-035</a>	—	—	●	
230	O-ring -gas valve	(2 required per assembly)	<a href="#">590-318-043</a>	●	●	●	
240	O-ring -blower	O-ring between blower and venturi	<a href="#">590-318-102</a>	●	●	●	
300	Pressure & temperature gauge	Shipped loose for field installation	<a href="#">380-000-000</a>	●	●	●	
310	Relief valve	30 PSIG relief valve — shipped loose for field installation	<a href="#">383-500-095</a>	●	●	—	
			<a href="#">383-900-076</a>	—	—	●	
320	Condensate drain trap	(not shown)	<a href="#">540-131-075</a>	●	—	—	
			<a href="#">540-131-076</a>	—	●	●	



# Replacement parts *(continued)*

**Figure 119** Piping components for Evergreen<sup>®</sup> 220/299/300/399 (see [Figure 118, page 124](#) for part numbers)



EV-153

Go to [www.weil-mclain.com](http://www.weil-mclain.com) to locate Weil-McLain distributors



# Replacement parts *(continued)*

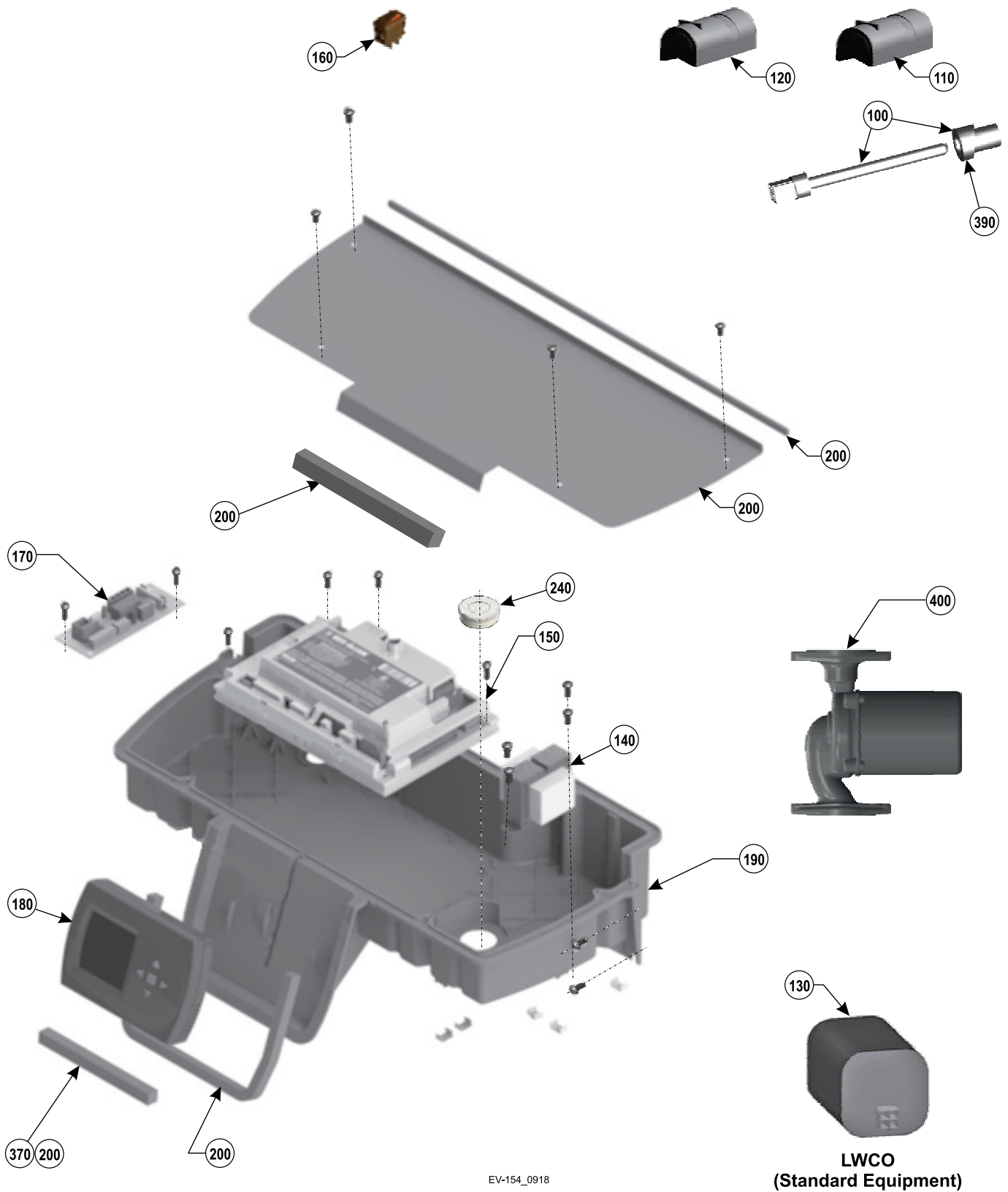
**Figure 120** Controls & electrical components — Evergreen<sup>®</sup> 220/299/300/399 (see [Figure 121](#), [page 127](#) for illustration)

Item	Name	Description / contents	Part Number
100	Flue temperature sensor	One sensor with gasket	383-500-600
110	Outdoor temperature sensor	One sensor	510-312-218
120	System temperature sensor	(2 required)	383-500-601
130	Low water cutoff	Low water cutoff	383-500-643
140	Transformer 120v/24v	50-60 Hertz transformer	511-802-011
150	Control assembly	Ignition control module	381-330-020
160	On/off power switch	20 Amp rated	511-624-645
170	Comm circuit board		383-900-089
180	Display board assembly	(Includes circuit board, communication cable and plastic housing)	383-900-078
190	Control tray	Plastic electrical enclosure (Includes gaskets and hardware)	383-900-079
200	Cover	(Includes gaskets and hardware)	383-900-029
240	Inspection window plug		591-491-217
250	F1 - 3 amp 120VDC, fast blow ato (not shown here — see <a href="#">Figure 97</a> , <a href="#">page 103</a> )	5 Fuses (used for boiler circulator)	383-900-081
260	F2 - 3 amp 32VDC, fast blow ato (not shown here — see <a href="#">Figure 98</a> , <a href="#">page 103</a> )	5 Fuses (used for low voltage circuit)	383-500-603
270	F3 - 12 amp 250 Volt, fast-blow ag (not shown here — see <a href="#">Figure 98</a> , <a href="#">page 103</a> )	5 Fuses (used for line voltage circuit)	383-500-604
280	Wire harness — High voltage	Wire harness (not shown)	591-392-007
290	Wire harness — Low voltage	Wire harness (not shown)	591-392-008
300	Wire harness — Communication Ethernet	Wire harness (not shown)	591-392-009
310	Wire harness — Low voltage Comm. board	Wire harness (not shown)	591-392-010
320	Wire harness — Blower	Wire harness (not shown)	591-392-011
330	Wire harness — Control/display comm.	Wire harness (not shown)	383-500-633
340	Wire harness — with receptacle and safety cap	Wire harness (not shown)	383-500-638
350	Ignition cable	Ignition cable (not shown)	591-392-012
360	Terminal block kit	Includes 1 high voltage terminal block, low voltage terminal blocks and screwdriver (not shown)	383-900-083
370	Gasket - display support		590-318-107
380	Cover ground terminal kit	(not shown)	383-900-098
390	Gasket - flue temperature sensor		590-318-011
400	Circulator Evergreen 220/299/300 Circulator Evergreen 399	Taco Pump 0014 Taco Pump 0013	511-405-133 511-405-140



# Replacement parts *(continued)*

**Figure 121** Controls & electrical assemblies — Evergreen<sup>®</sup> 220/299/300/399 (see [Figure 120, page 126](#) for part numbers)



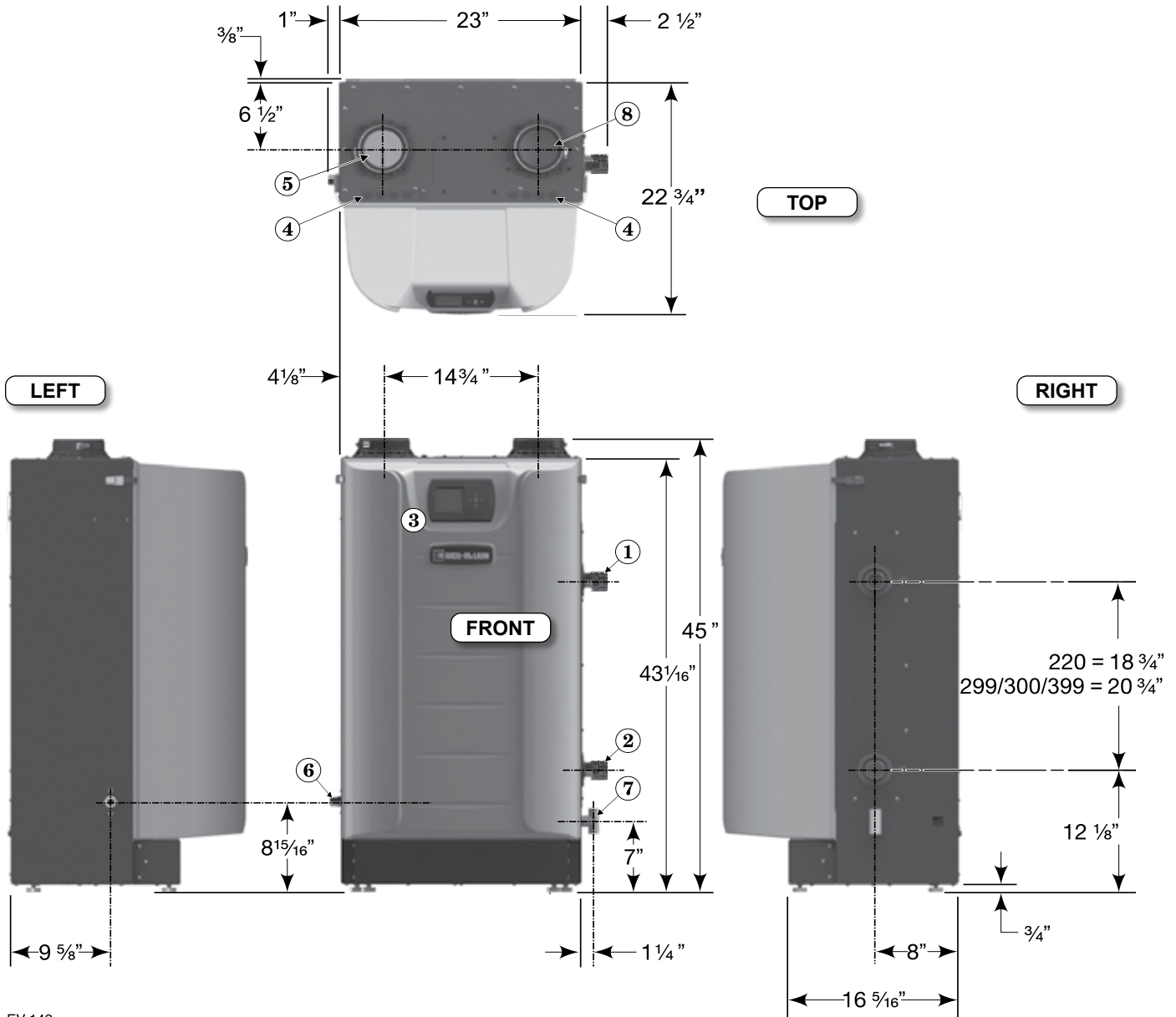
EV-154\_0918

**LWCO**  
**(Standard Equipment)**



# Dimensions

**Figure 122** Dimensional data — Evergreen<sup>®</sup> 220/299/300/399 (all dimensions in inches)



EV-142

- |  |  |
|--|--|
| <ul style="list-style-type: none"> <li>1 Boiler supply tapping — 1 1/2" NPT.</li> <li>2 Boiler return tapping — 1 1/2" NPT.</li> <li>3 Control panel, with display and navigation buttons.</li> <li>4 Electrical entrance openings.</li> <li>5 Vent connection: 4" PVC.</li> </ul> | <ul style="list-style-type: none"> <li>6 Gas connection – 3/4" NPT (manual gas valve shipped loose for field installation) See <a href="#">page 51</a> for details and instructions.</li> <li>7 Condensate drain connection.</li> <li>8 Air connection: 4" PVC.</li> </ul> |
|--|--|



# Ratings

Figure 123 Ratings and engineering data — Evergreen<sup>®</sup> 220/299/300/399

DOE



### AHRI Certified Ratings

Boiler Model	Input	Heating Capacity	Seasonal Efficiency	Net Water Rating	% Input derate vs vent length (Values shown are at MAX vent/air pipe length — See Note 6) Direct Vent Venting ONLY				Boiler Water Content	Vent/ Comb. Air Connection Diameter
					Natural gas		Propane			
					3" Vent/air piping	4" Vent/air piping	3" Vent/air piping	4" Vent/air piping		
<b>EVG 220</b>	220,000	206	95.0	179	7.2%	2.1%	7.2%	2.1%	4.6	3 or 4" PVC
<b>EVG 299</b>	299,000	280	95.0	243	N/A	2.7%	N/A	2.7%	7.0	4" PVC

Boiler Model	CSA Input	Gross Output	Net Rating	Combustion Efficiency	Thermal Efficiency	% Input derate vs vent length (Values shown are at MAX vent/air pipe length — See Note 6) Direct Vent Venting ONLY		Boiler Water Content	Vent/ Comb. Air Connection Diameter
						Natural gas	Propane		
						4" Vent/air piping	4" Vent/air piping		
<b>EVG 300</b>	300,000	286	248	96.0	95.5	2.7%	2.7%	7.0	4" PVC
<b>EVG 399</b>	399,000	383	333	96.5	96.0	4.3%	4.3%	6.7	4" PVC

### Notes

- As an Energy Star Partner, Weil-McLain has determined that Evergreen<sup>®</sup> 220 and 299 boilers meet the Energy Star guidelines for energy efficiency. NOTE: Adjusting boiler firing rate will affect AFUE rating.
- Based on standard test procedures prescribed by the United States Department of Energy. Ratings also referred to as CSA Output. NOTE that only DOE Heating Capacity and AFUE are certified by AHRI. AFUE is also known as Annual Fuel Utilization Efficiency or Seasonal Efficiency.
- Net AHRI ratings are based on net installed radiation of sufficient quantity for requirements of the building and nothing need be added for normal piping and pickup. Ratings are based on a piping and pickup allowance of 1.15. An additional allowance should be made for unusual piping and pickup loads.
- Evergreen<sup>®</sup> boilers are designed to be direct-vented. Evergreen<sup>®</sup> boilers require special venting, consistent with Category IV boiler. Use only the vent materials and methods specified in this manual. Evergreen<sup>®</sup> boilers may be direct exhaust vented. Evergreen<sup>®</sup> 220 vent/air pipes can be either 3" or 4". Evergreen<sup>®</sup> 299/300/399 vent/air pipes must be 4".
- Ratings shown are for sea level applications only. For altitudes from sea level to 2000 feet above sea level, the Evergreen<sup>®</sup> boiler requires no modifications. The boiler automatically derates itself by approximately 4% per 1000 feet above sea level.
- All of the boilers will automatically de-rate as vent/air pipe length increases, due to the pressure loss through the piping. For vent/air pipe lengths less than the maximum, the derate equals the value above times vent length ÷ 100.

### THE OUTDOOR SENSOR SUPPLIED WITH THE BOILER MUST BE INSTALLED UNLESS EXEMPTED BELOW:

#### IMPORTANT

In accordance with **Section 303 of the 2007 Energy Act**, this boiler is equipped with a feature that saves energy by reducing the boiler water temperature as the heating load decreases. This feature is equipped with an override which is provided primarily to permit the use of an external energy management system that serves the same function.

**THIS OVERRIDE MUST NOT BE USED UNLESS AT LEAST ONE OF THE FOLLOWING CONDITIONS IS TRUE:**

- An external energy management system is installed that reduces the boiler water temperature as the heating load decreases.
- This boiler is not used for any space heating.
- This boiler is part of a modular or multiple boiler system having a total input of 300,000 BTU/hr or greater.
- This boiler is equipped with a tankless coil (not applicable to Evergreen<sup>®</sup>).



# Ratings — Multiple boilers

Figure 124 Ratings and engineering data — multiple Evergreen® boilers

Boilers in system			Total CSA input	CSA Output /DOE Heating capacity	Boiler H.P.	Net water ratings	Manifolded combustion air duct size
			Input, MBH	Output, MBH	-	MBH	Square inches
EVG 220	EVG 299/300	EVG 399	-	Note 1	-	Note 2	
2			440	412	12.3	358	220
	2		598	560	16.7	486	300
		2	798	766	22.9	666	400
3			660	618	18.5	537	330
	3		897	840	25.1	729	450
		3	1197	1149	34.4	999	600
4			880	824	24.6	716	440
	4		1196	1120	33.5	972	600
		4	1596	1532	45.8	1332	800
5			1100	1030	30.8	895	550
	5		1495	1400	41.9	1215	750
		5	1995	1915	57.3	1665	1000
6			1320	1236	36.9	1074	660
	6		1794	1680	50.2	1458	900
		6	2394	2298	68.7	1998	1200
7			1540	1442	43.1	1253	770
	7		2093	1960	58.6	1701	1050
		7	2793	2681	80.2	2331	1400
8			1760	1648	49.2	1432	880
	8		2392	2240	67.0	1944	1200
		8	3192	3064	91.6	2664	1600

Boiler Model	Shipping weight	Operating weight	Water content	Water flow rate per boiler		Vent/air pipe size: (Provide a separate vent for each boiler)	Electrical service required
	Pounds per boiler	Pounds per boiler	Gallons per boiler	GPM @ 20°F rise	GPM @ 40°F rise		Amps per boiler
		Note 4		Note 5	Note 3		
EVG 220	215	190	4.6	22	11	3" or 4"	15.0
EVG 299/300	260	255	7.0	30	15	4"	15.0
EVG 399	260	255	6.7	40	20	4"	15.0

**Notes**

- 1 Based on standard test procedures outlined by DOE for individual boilers.
- 2 Net water ratings are based on piping and pickup allowance of 1.15. Consult Weil-McLain Technical Services for other allowances.
- 3 Total amp requirement includes up to three circulators, not exceeding 2.2 amps per circulator.
- 4 Operating weight is the total weight of the boiler, including water.
- 5 Evergreen® 220 vent/air pipes can be either 3" or 4" pipe.  
 Evergreen® 299/300/399 vent/air pipes must be 4".  
 All of the boilers will automatically de-rate as vent/air pipe length increases, due to the pressure loss through the piping. See Figure 123, page 129 for details.  
 All Evergreen® installations require a separate vent pipe and termination for each boiler. **Vent piping cannot be manifolded.** Install and terminate vents as described in vent/air installation instructions in this manual.  
 Combustion air piping can be individually piped or manifolded. See Advanced Manual for manifolded air piping.



# Installation and Service Certificate

Boiler Data		
Boiler Model / Series Evergreen <sup>®</sup> _____ / Series _____	Date installed _____	
CP Number _____	FUEL: Natural _____ LP _____	Btu Input _____
<p><b>CERTIFIED THAT:</b></p> <ul style="list-style-type: none"> <li><input type="checkbox"/> Installation instructions have been followed.</li> <li><input type="checkbox"/> Check-out sequence has been performed.</li> <li><input type="checkbox"/> Information on next two pages is certified to be correct.</li> <li><input type="checkbox"/> Information received and left with owner/maintenance person.</li> </ul>		
Installer	_____	_____
	_____	_____
	(Company) (Address)	(Phone) (Installer's Signature)



# Installation and Gas Boiler Data Collection Sheet

Boiler Model / Series EVG _____ / Series _____		Date Installed: _____	
CP Number: _____	Fuel Type: Natural___ LP___	BTU Input: _____	
Flame signal on control display at HIGH fire: _____		Flame signal on control display at LOW fire: _____	
Was venturi changed? YES___ NO___	Was gas valve throttle adjusted? YES___ NO___	Was gas valve offset adjusted? YES___ NO___	
Boiler Settings		Network Settings	
Boiler Model: EVG _____	Boiler Address: _____	System Type:	_____
Control Type: _____	Net Max On Time: _____ Min	Target Mod Sensor:	_____
Altitude: _____ Feet	Net Min On Time: _____ Min	Target Adjust:	_____
LP Gas: YES___ NO___	Max Rate On Net: _____%	Supply Max:	_____ °F
ODT Sensor Exempt: YES___ NO___	Min Rate On Net: _____%	Supply Min:	_____ °F
Manual Reset High Limit Temp: _____ °F	Rotation & Sequence	OD Reset Max:	_____ °F
WWSD Temp: _____ °F	Sequence Type: _____	OD Reset Min:	_____ °F
Adjust Outdoor: _____ °F	Base Rate High: _____%	Volts For Max:	_____ V
Circulator Exercising	Base Rate Low: _____%	Volts For Min:	_____ V
Circulator 1: ON___ OFF___	Boiler Rotation Type: _____	Boost Time:	_____ Mins
Circulator 2: ON___ OFF___	Rotate Frequency: _____ Days	System Off Diff:	_____ °F
Circulator 3: ON___ OFF___	Force Lead Rotation: YES or NO	System On Diff:	_____ °F
Boiler Circ: ON___ OFF___	Modbus Settings	Add BLR Diff:	_____ °F
Freeze Protection	Enable: YES___ NO___	Drop BLR Diff:	_____ °F
Circulator 1: ON___ OFF___	Address: _____	Mod Delay Time:	_____ Mins
Circulator 2: ON___ OFF___	Parity Bit: _____	Stabilization Time:	_____ Mins
Circulator 3: ON___ OFF___	Baud Rate: _____ bps	Add Delay Time:	_____ Sec
Boiler Circ: ON___ OFF___	Stop Bit: YES___ NO___	Drop Delay Time:	_____ Sec
Assign Inputs		Max BLR Temp:	_____ °F
Input 1: Priority___ Aux___ OFF___		Boiler On Diff:	_____ °F
Source: TT1 ___ OR 0-10V ___		Boiler Off Diff:	_____ °F
Input 2: Priority___ Aux___ OFF___		Max On Time:	_____ Mins
Input 3: Priority___ Aux___ OFF___		Run Boiler Pump:	YES___ NO___
		Run Aux Pump/Output:	YES___ NO___
		Pre Pump:	_____ Sec
		Post Pump:	_____ Sec
		Max Rate:	_____ %
		Min Rate:	_____ %
		Max System BTUs:	_____ MBUTs
		Min Boilers On:	_____
		Additional Heat Demand:	1st___ 2nd___ OFF___
		Response Time:	_____ Mins



# Installation and Gas Boiler Data Collection Sheet

CO2 @: High Fire _____% Low Fire _____%					
CO@: High Fire _____ ppm Low Fire _____ ppm					
Natural Gas / LP input rate measured: HIGH _____ CFH / LOW _____ CFH					
Priority 2 Settings		Priority 3 Settings		Priority 4 Settings (Multi BLR Sys Only)	
System Type:	_____	System Type:	_____	System Type:	_____
Target Mod Sensor:	_____	Target Mod Sensor:	_____	Target Mod Sensor:	_____
Target Adjust:	_____	Target Adjust:	_____	Target Adjust:	_____
Supply Max:	_____°F	Supply Max:	_____°F	Supply Max:	_____°F
Supply Min:	_____°F	Supply Min:	_____°F	Supply Min:	_____°F
OD Reset Max:	_____°F	OD Reset Max:	_____°F	OD Reset Max:	_____°F
OD Reset Min:	_____°F	OD Reset Min:	_____°F	OD Reset Min:	_____°F
Volts For Max:	_____ V	Volts For Max:	_____ V	Volts For Max:	_____ V
Volts For Min:	_____ V	Volts For Min:	_____ V	Volts For Min:	_____ V
Boost Time:	_____ Mins	Boost Time:	_____ Mins	Boost Time:	_____ Mins
System Off Diff:	_____°F	System Off Diff:	_____°F	System Off Diff:	_____°F
System On Diff:	_____°F	System On Diff:	_____°F	System On Diff:	_____°F
Add BLR Diff:	_____°F	Add BLR Diff:	_____°F	Add BLR Diff:	_____°F
Drop BLR Diff:	_____°F	Drop BLR Diff:	_____°F	Drop BLR Diff:	_____°F
Mod Delay Time:	_____ Mins	Mod Delay Time:	_____ Mins	Mod Delay Time:	_____ Mins
Stabilization Time:	_____ Mins	Stabilization Time:	_____ Mins	Stabilization Time:	_____ Mins
Add Delay Time:	_____ Sec	Add Delay Time:	_____ Sec	Add Delay Time:	_____ Sec
Drop Delay Time:	_____ Sec	Drop Delay Time:	_____ Sec	Drop Delay Time:	_____ Sec
Max BLR Temp:	_____°F	Max BLR Temp:	_____°F	Max BLR Temp:	_____°F
Boiler On Diff:	_____°F	Boiler On Diff:	_____°F	Boiler On Diff:	_____°F
Boiler Off Diff:	_____°F	Boiler Off Diff:	_____°F	Boiler Off Diff:	_____°F
Max On Time:	_____ Mins	Max On Time:	_____ Mins	Min On Time:	_____ Mins
Min On Time:	_____ Mins	Run Boiler Pump:	YES___ NO___	Run Boiler Pump:	YES___ NO___
Run Boiler Pump:	YES___ NO___	Run Aux Pump/Output:	YES___ NO___	Run Aux Pump/Output:	YES___ NO___
Run Aux Pump/Output:	YES___ NO___	Pre Pump:	_____ Sec	Pre Pump:	_____ Sec
Pre Pump:	_____ Sec	Post Pump:	_____ Sec	Post Pump:	_____ Sec
Post Pump:	_____ Sec	Max Rate:	_____ %	Max Rate:	_____ %
Max Rate:	_____ %	Min Rate:	_____ %	Min Rate:	_____ %
Min Rate:	_____ %	Max System BTUs:	_____ MBUTs	Max System BTUs:	_____ MBUTs
Max System BTUs:	_____ MBUTs	Min Boilers On:	_____	Min Boilers On:	_____
Min Boilers On:	_____	Additional Heat Demand:	1st___ 2nd___ OFF___	Additional Heat Demand:	1st___ 2nd___ OFF___
Additional Heat Demand:	1st___ 2nd___ OFF___	Response Time:	_____ Mins	Response Time:	_____ Mins
Response Time:	_____ Mins				





