

OPERATIONS MAINTENANCE MANUAL

COOK & HOLD OVEN SYSTEMS

TOUCHMASTER OVEN SERIES

WITTCO MODEL NUMBERS

TOUCHMASTER I
TOUCHMASTER II
TOUCHMASTER III
TOUCHMASTER IV



wittco

foodservice
equipment

LIMITED WARRANTY

Wittco warrants the Products that it manufactures to be free from defects in materials and workmanship, under normal use and service, for the periods indicated below from the date of purchase when installed and maintained in accordance with Wittco's written instructions. Buyer must establish the "Products" purchase date by returning Wittco's Warranty registration Card or by other means satisfactory to Wittco in its sole discretion.

Wittco warrants its Products to be free from defects in materials and workmanship from the date of purchase (subject to the foregoing conditions) for the period(s) of time and on the conditions listed below:

- a) **Ninety (90) days Labor Warranty**
- b) **One (1) Year Parts Warranty**

THE FOREGOING WARRANTIES ARE EXCLUSIVE AND IN LIEU OF ANY OTHER WARRANTY, EXPRESSED OR IMPLIED, INCLUDING BUT NOT LIMITED TO ANY IMPLIED WARRANTY OF MERCHANTABILITY OR FITNESS FOR A PARTICULAR PURPOSE OR PATENT OR OTHER INTELLECTUAL PROPERTY RIGHT INFRINGEMENT. Without limiting the generality of the foregoing, **SUCH WARRANTIES DO NOT COVER:** Coated incandescent light bulbs or heat lamps, all glass components, Product misuse, tampering, misapplication, application of improper voltage, or recalibration of thermostats or high limit switches.

LIMITATION OF REMEDIES & DAMAGES

Wittco's liability and Buyer's exclusive remedy hereunder will be limited solely, at Wittco's option, to repair or replacement by a Wittco authorized service agency (other than where Buyer is located outside of the United States or Canada, in which case Wittco's liability and Buyer's exclusive remedy hereunder will be limited solely to replacement of part under warranty) with respect to any claim made within the applicable warranty period referred to above. Without limiting the generality of the foregoing, all portable Products, as defined by Wittco, shall be delivered by Buyer, at its sole expense, to the nearest Wittco authorized service agency for replacement or repair. Wittco reserves the right to accept or reject any such claim in whole or in part. Wittco will not accept the return of any Product without prior written approval from Wittco, and all such approved returns shall be made at Buyer's sole expense. **WITTCO WILL NOT BE LIABLE, UNDER ANY CIRCUMSTANCES, FOR CONSEQUENTIAL OR INCIDENTAL DAMAGES, INCLUDING BUT NOT LIMITED TO LABOR COSTS OR LOSS OF PRODUCTS AND LOSS OF PROFITS RESULTING FROM THE USE OF OR INABILITY TO USE THE PRODUCTS.**



WITTCO TECHNICAL & PRODUCT SUPPORT

TECHNICAL SUPPORT & SERVICE INQUIRES MAY BE DIRECTED TO WITTCO BY:

1. **CALLING DIRECTLY TO:**

WITTCO FOODSERVICE EQUIPMENT TECHNICAL & SERVICE DEPARTMENT - (800)
367-8413
8:00 AM - 4:30 PM (CENTRAL TIME)

2. **FAXING DIRECTLY TO:**

WITTCO FOODSERVICE EQUIPMENT TECHNICAL & SERVICE DEPARTMENT - (414)
354-2821
DAILY 24 HOURS

3. **MAILING DIRECTLY TO:**

WITTCO FOODSERVICE EQUIPMENT INC.
7737 NORTH 81ST. STREET
MILWAUKEE, WISCONSIN 53223
USA

WHEN DIRECTING INQUIRIES TO WITTCO PLEASE HAVE THE FOLLOWING INFORMATION AVAILABLE TO AVOID DELAYS

1. Wittco model number indicated on the equipment serial data plate located at the electrical connection.
2. Wittco serial number indicated on the equipment serial data plate. The equipment serial number will also have two (2) alpha characters immediately following the serial number. These alpha characters are part of the serial number.



INTRODUCTION

Wittco Foodservice Equipment's Touchmaster Cook and Hold Oven System is a basic unit of food preparation equipment. It has found wide acceptance in both institutional and commercial food service operations.

This manual has been produced to provide persons responsible for the operation and maintenance of the oven with a simple but comprehensive understanding of its proper use. We recommend that this manual be read and understood prior to placing the oven into operation.

As with any piece of food service equipment, this oven system will require a minimum of care and maintenance. Suggestions for this procedure are contained in this manual and should become a regular part of the operation of the unit.

NOTE: BEFORE USING THE OVEN IT SHOULD BE THOROUGHLY CLEANED IN ACCORDANCE WITH THE INSTRUCTIONS CONTAINED IN THIS MANUAL.

It is recommended that prior to placing the oven system into operation that it be operated on the cook cycle for approximately two (2) hours at 350° F.

Should repair or adjustment of the unit become necessary, we suggest that procedures described in this manual be followed. The operator may also contact the authorized Wittco dealer who sold the product or an authorized Wittco service agency. If the needed repair occurs during the warranty period, prior authorization is required from Wittco by the service company before the work is commenced.

It is our sincere desire that you obtain the maximum benefit from your Cook and Hold Oven System. If at any time questions arise or additional information is required, contact Wittco at 800 367-8413.

DESCRIPTION

Operators have found that cooking foods utilizing low temperature methods reduces the amount of product shrinkage and increases the amount of product yield. This is because less moisture is cooked out of the food when it is prepared at 225° F. than when it is prepared at 350° F. Because of this fact, the operator will serve a product that has greater customer satisfaction because of the increased flavor and moisture this meat possesses.

UNCRATING

Each Wittco Foodservice Equipment oven is packed in a cardboard carton which, in turn, is banded to a wooden pallet. When the cabinet is received by the operator, the carton should immediately be inspected for any sign of visible exterior damage. If carton is

punctured or dented, it may be an indication that the cabinet has sustained concealed freight damage.

It is very important that any evidence of damage be noted on the Bill of Lading at the time of receipt.

UNPACKING THE CABINET

1. Remove the banding material holding the carton to the pallet.
2. Remove the cardboard carton and the plastic bag covering the cabinet.
3. Carefully lift the cabinet off the carton bottom and pallet and place it on the floor.
Note: The casters for the Touchmaster III are shipped in a separate carton. Remove it and install the casters on the oven.
4. Remove the box containing the cooking racks that are supplied with the oven.
5. Remove any packing materials which may have been used to hold the tray slides in place.
6. Heat the oven at 350° F for approximately 2 hours before using.

CABINET LOCATION

PLACING THE OVEN IN THE PROPER LOCATION IS IMPORTANT FOR EFFICIENT OPERATION. CHOOSE A LOCATION FOR THE OVEN IN AN AREA WHICH WILL PROVIDE EASY LOADING AND UNLOADING WITHOUT INTERFERING WITH THE FINAL ASSEMBLY OF FOOD ORDERS. PROVIDE AT LEAST SIX INCHES OF SPACE ON EACH SIDE OF THE OVEN FOR PROPER AIR CIRCULATION AROUND THE OVEN.

OPERATING CONTROLS

A complete explanation of the operating controls will be found in the Cook Guide which is supplied with the oven.

All operating controls are located on the front control panel. This panel contains the on/off button and the touch pad operating controls.

NOTE: IT IS RECOMMENDED THAT THE OVEN CONNECTION TO THE POWER SOURCE BE DONE BY A LICENSED ELECTRICIAN.

NOTE: UPON CONNECTING THE CONTROL MODULE TOP TO THE POWER SOURCE, THE COOLING FANS MAY NOT OPERATE. THESE FANS WILL ONLY OPERATE WHEN THE THERMOSTAT TO WHICH THEY ARE CONNECTED REQUIRES IT.

ELECTRICAL REQUIREMENTS

Wittco Cook and Hold Ovens can be factory wired for 120, 208,220, or 240 volts AC, single or three phase, 60 or 50 cycle service.

VERIFY THAT THE VOLTAGE AND PHASE OF THE POWER SOURCE IS IDENTICAL TO THE OVEN SYSTEM DATA PLATE BEFORE CONNECTING.

The oven must be adequately and safely grounded before operation. A separate disconnect switch or circuit breaker is recommended at a convenient location between the oven and power source.

TESTING THE OVEN

Each oven is completely checked and tested prior to shipment. However, it is a good practice to completely check the unit again after unpacking and installation.

- 1. Connect oven to power source.**
2. Turn the oven on by depressing the power button.
3. Set the roasting oven temperature by depressing the up/down arrow touch pad until the LED display reads 350° F and then depress the enter touch pad.

4. Set the hold temperature by pushing the up/down arrow touch pads until the LED display reads 140° F and then depress the enter touch pad.
5. Set the roasting time by pushing the time touch pad and the up/down arrows until the LED indicator shows 1:00 (one hour)
6. Depress the start cook touch pad.
7. The oven should immediately start heating. The red “heat” indicator light will illuminate. At this time the LED will read 01:00 in the top section and the bottom section will read 350. The Cook indicator light will also be illuminated. The oven timer will begin to count down to 0:00 and when it reaches that point the oven will switch from the roasting to the holding cycle.

If all of the functions perform satisfactorily, the oven is ready for operation.

CLEANING

The interior of the oven should be cleaned whenever a food spill occurs. Use a mild soap and water to clean. **Never use harsh chemicals or abrasive pads to clean the cabinet.** The simple cleaning process follows.

1. **DISCONNECT THE OVEN FROM THE POWER SOURCE.**
2. Remove the control module top and place it away from the oven cabinet.

CAUTION - THE OVEN INTERIOR COMPARTMENT SHOULD NEVER BE HOSED DOWN WHEN THE CONTROL MODULE TOP IS ON THE OVEN BODY.

3. Lift and tip the side tray racks toward the center of the cabinet. Remove them from the cabinet. These racks should be taken to a sink or dish washer for a thorough cleaning.
4. Remove the interior rear mounted air distribution tunnel and take it to a sink or dish washer for cleaning.
5. Clean the interior oven cavity with soap and water.
6. Reassemble the oven.

REPLACEMENT OF ELECTRICAL COMPONENTS

It is highly recommended that only Wittco Foodservice Equipment replacement parts be used to insure compatibility of component parts in the operation of cook and hold oven

systems. All of the electrical components which may require servicing are in the control module top.

WARNING: DISCONNECT THE OVEN FROM THE POWER SOURCE BEFORE REMOVING THE CONTROL MODULE TOP FROM THE OVEN CABINET.

ON/OFF SWITCH REPLACEMENT

1. **DISCONNECT THE OVEN FROM THE POWER SOURCE.**
2. Remove the protective cover from the control module top.
3. Notice the arrangement of all electrical leads and refer to the wiring diagram for reference.
4. Disconnect the lead wires from the power switch
5. Remove the rear mount hex nut which holds the switch on the control panel.
6. Remove the switch assembly by pushing it from the rear through the control panel.
7. Install the replacement switch in the reverse order of above.
8. Reinstall the control module cover.
9. Test the oven as described in the TESTING THE OVEN section.

COOK/HOLD ELECTRONIC TOUCH PAD CONTROLLER REPLACEMENT

1. **DISCONNECT THE OVEN FROM THE POWER SOURCE.**
2. Remove the top cover by removing the retaining screws and lifting it off the control module top.
3. Notice the arrangement of all electrical leads and refer to the wiring diagram for reference.
4. Disconnect the electrical leads of the temperature control needing replacement from the circuit board.
5. Carefully remove the four nuts which secure the circuit board to the back of the control panel.
7. Remove the circuit board from the control panel.

COOK/HOD ELECTRONIC TOUCH PAD CONTROLLER (CON'T)

8. Install the replacement circuit board following the reverse of the above procedure.
9. Reinstall the control module cover and screws.
10. Test the oven as described in the TESTING THE OVEN section.

FOOD PROBE CONNECTOR REPLACEMENT 1. DISCONNECT THE OVEN FROM THE POWER SOURCE.

2. Remove the top cover by removing the screws and lifting the cover off the control module top to expose the food probe connector.
3. Notice the arrangement and connection of all electrical leads and refer to the wiring diagrams for reference.
4. Locate the food probe “female” connector mounted to the front of the control panel and disconnect the wire harness from the circuit board assembly.
5. Remove the probe connector screw securing the connector to the control panel.
6. Install the replacement connector in the reverse order of above.
9. Reinstall the control module cover and screws.
10. Test the oven as described in the TESTING THE OVEN section.

COOLING FAN REPLACEMENT 1. DISCONNECT THE OVEN FROM THE POWER SOURCE.

2. Remove the top cover by removing the screws and lifting the cover off the control module top to expose the cooling fans.
3. Notice the arrangement and connection of all electrical leads and refer to the wiring diagrams for reference.
4. Disconnect the electrical plug to the cooling fan and remove it.
5. Install the replacement cooling fan.
NOTE: THE AIR FLOW DIRECTION ARROW MUST POINT TO THE LEFT OR AWAY FROM THE CONTROL MODULE TOP.
6. Reconnect the electrical leads to the cooling fan.

COOLING FAN REPLACEMENT (CON'T)

7. Reinstall the module control top cover and screws.
8. Test the oven as described in the TESTING THE OVEN section.

COOLING FAN THERMOSTAT REPLACEMENT

1. **DISCONNECT THE OVEN FROM THE POWER SOURCE.**
2. Remove the top cover by removing the screws and lifting the cover off the control module top to expose the cooling fan thermostat.
3. Notice the arrangement and connection of all electrical leads and refer to the wiring diagrams for reference.
4. Disconnect the electrical leads to the cooling fan thermostat and remove it.
5. Install the replacement cooling fan thermostat.
6. Reconnect the electrical leads to the cooling fan thermostat.
7. Reinstall the module control top cover and screws.
8. Test the oven as described in the TESTING THE OVEN section.

BLOWER ASSEMBLY REPLACEMENT

1. **DISCONNECT THE OVEN FROM THE POWER SOURCE.**
2. Remove the top cover by removing the screws and lifting the cover off the control module top to expose the blower assembly.
3. Notice the arrangement and connection of all electrical leads and refer to the wiring diagrams for reference.
4. Disconnect the electrical leads to the blower assembly at the terminal strip.
5. Remove the protective fan grill located on the bottom of the control module top exposing the blower cage.
6. Insert an "L-end" wrench into the set screw holding the blower to the motor shaft. Remove the cage from the blower motor.

BLOWER MOTOR REPLACEMENT (CON'T)

7. Remove the three (3) hex nuts holding the blower motor housing to the oven and remove it.
8. Install the replacement blower motor by following the reverse of the directions above.
9. Reconnect the electrical leads to the blower assembly.
10. Reinstall the module control top cover and screws.
11. Test the oven as described in the TESTING THE OVEN section.

HEATING ELEMENT REPLACEMENT

1. **DISCONNECT THE CABINET FROM THE POWER SOURCE.**
2. Remove the top cover by removing the screws and lifting the cover off the control module top.
3. Remove all the insulation surrounding the heating element compartment and save it for reuse.
4. Remove the screws from the heating element cover to expose the elements.
5. Notice the arrangement and connection of all electrical leads and refer to the wiring diagrams for reference.
6. Disconnect the electrical leads from the heating elements
7. Remove the nuts securing the heating element to the heating element compartment and remove it.
8. Install the replacement heating element by following the reverse of the above directions.
9. Reinstall the module control top cover and screws.
10. Test the oven as described in the TESTING THE OVEN section.

ELECTRICAL RELAY REPLACEMENT

1. **DISCONNECT THE CABINET FROM THE POWER SOURCE.**
2. Remove the top cover by removing the screws and lifting the cover off the control module top exposing the electrical relay.
3. Remove the defective relay but leave the wires attached. Notice the arrangement and connection of all electrical leads and refer to the wiring diagrams for reference.
4. Install the new relay and move the wires from the defective relay to the terminal screws on the replacement relay.
5. Reinstall the module control top cover and screws.
6. Test the oven as described in the TESTING THE OVEN section.

TEMPERATURE CONTROL SENSING PROBE REPLACEMENT

1. **DISCONNECT THE OVEN FROM THE POWER SOURCE.**
2. Remove the top cover by removing the screws and lifting the cover off the control module top exposing the temperature sensing probe.
3. Notice the arrangement and connection of all electrical leads between the sensing probe and the circuit board and refer to the wiring diagrams for reference.
4. Disconnect the probe lead wires from the solid state circuit board. These wires are not polarity sensitive.
5. Remove the wire ties that hold the probe wires to the other wires.
6. Remove the wire ties that hold the sensing probe to the fan grill on the inside of the oven.
7. Remove the insulating grommet from the probe wires and gently pull the probe through the access hole in the top of the oven compartment.
8. Install the replacement temperature probe by following the reverse of the above directions.
9. Reinstall the module control top cover and screws.
10. Test the oven as described in the TESTING THE OVEN section.

TROUBLE SHOOTING PROCEDURE

WARNING: EXTREME CAUTION MUST BE EXERCISED WHEN WORKING AROUND ELECTRICAL EQUIPMENT TO PREVENT THE POSSIBILITY OF ELECTRICAL SHOCK RESULTING IN INJURY OR DEATH. THESE TEST PROCEDURES SHOULD ONLY BE DONE BY A LICENSED ELECTRICIAN OR AN AUTHORIZED SERVICE AGENCY.

Always work in a safe manner. Be sure the power supply is turned off before touching any wires or terminals to prevent the possibility of electrical shock or damage as a result of electrical short by the meter probes.

No wires should be disconnected from the terminals without first disconnecting the power source to the oven.

This procedure supplies a list of symptoms that may be observed and a reference section that may be referred to locate and correct the problem.

TEST EQUIPMENT REQUIRED

The preferred piece of equipment required is a DVM (Digital Voltmeter) and a clamp-on ammeter. If one of these is not available, an ohmmeter is necessary to determine if a short circuit or a ground exists. The meter should be capable of reading 0 to 100 k ohms full scale.

NORMAL OPERATION

It is preferred that the technician has had the opportunity to observe the normal operation of the oven so that when there is a malfunction, it may be easily recognized with a minimum of testing.

In normal operation, as soon as power is applied to the oven and the power switch is turned on, the HEAT and the COOK CYCLE indicator lights should be illuminated. In addition, the air circulating fans inside the oven should start.

TROUBLE SHOOTING

I. NO HEAT IN THE HOLD CYCLE

1. Check that the oven is connected to the power source and the circuit breaker or fuse is not tripped.
2. Check that the oven power switch is on.
3. If the power switch is in the on position and the heat indicator light is not illuminated, remove the fuses and verify continuity with the ohmmeter. If the fuses

are defective, there is probably a shorted component or wire. Refer to Section A for additional testing.

Replace fuses with the same type that were supplied with the oven. Use only #SLC-3 current limiting fuse, Type G, 250 volt.

II. **ERROR DETECTION**

1. When a “000” is displayed in the lower LED display during a Cook or Hold cycle, it indicates that the temperature sensing probe is open or shorted.
2. When a “000” is displayed in the lower LED display during a probe cook function, it indicates that the product sensing probe is open or shorted.

SECTION A. TESTING FOR GROUNDS AND/OR SHORTED COMPONENTS

DISCONNECT THE OVEN FROM THE POWER SOURCE BEFORE PERFORMING ANY TESTING WITH AN OHMMETER

TESTING FOR GROUNDS

1. Power switch in the off position.
2. Connect on lead of the ohmmeter to the metal oven top.
3. Touch the other lead to the following and observe that there should be an open circuit in each case:
 - T1 on element contactor
 - T2 of element contactor
 - Wire 7 on vent fan switch
 - Wire 29 on power switch
 - Wire 50 on power switch
 - Wire 10 on power switch
 - Wire 29 on power switchAny reading at all, indicates a component partially or completely shorted to ground.

TESTING FOR SHORTED COMPONENTS

Test the following to determine which component is shorted. If any component has significantly lower reading than is listed, it is suspect and should be replaced.

TESTING HEATING ELEMENTS

Test between T1 and T2 on the contactor with the ohmmeter and compare the value to the table below:

The basic element has a resistance of 23 ohms regardless of the voltage rating on the oven. Because the number of elements in the oven affects the reading, compare the number of elements in the oven to the following chart to determine if any elements are open or shorted.

1 element	2 elements	3 elements	3 elements 3 PH
23 ohms	11.5 ohms	7.7 ohms	L1-L2 15.3 ohms L1-L3 15.3 ohms L2-L3 15.3 ohms

TESTING COOLING FAN MOTORS

Test wire 7 to wire 50 on the cooling fan motors. A typical reading on a 120 volt oven is 47 ohms. A 208/240 volt oven will have 183 ohms.

NOTE: These readings are for two fans connected in parallel. A new replacement fan will read double.

TESTING BLOWER MOTORS

1. Disconnect the blower motor wires from the terminal strip and test with an ohmmeter to determine whether they are shorted or not. The reading should be approximately as shown in the table below. If a discrepancy exists, check each motor individually.

Voltage	1 Blower	2 Blowers	3 Blowers
120 Volt	19 ohms	9.5 ohms	6.3 ohms
208/240 Volt	70 ohms	35 ohms	23.3 ohms

Reconnect the wires to the terminal strip.

WIRING INSPECTION

Check for frayed or touching wires on any terminal strip, especially on the set point relay. Clean and dress up the wires as needed.

TESTING THE MOV VARISTOR

Lift one wire of each MOV from the terminal and check with an ohmmeter. If the reading is less than 100K ohms, the unit is defective.

TESTING THE CONTACTOR COIL

Disconnect all wires from one side terminal of the contactor coil. The ohmmeter should read approximately 675 ohms for a 208/240 volt unit or 235 ohms for a 120 volt unit. If the circuit is open or shorted, the contactor must be replaced.

TESTING THE ROASTING TIMER COIL

Disconnect all wires from terminal #1. The ohmmeter should read approximately 520 ohms for a 240 volt unit or 140 ohms for a 120 volt unit. If the circuit is open or shorted, the timer must be replaced.

TESTING THE SET POINT RELAY COIL

Unplug the set point relay from its socket and measure coil resistance. Ohmmeter should read approximately 17.2K ohms across relay coil contacts.

SECTION E GENERAL VOLTAGE TESTING

Test for line voltage between the following:

L1 and L2 on the contactor.

Wires 29 and 50 on the power switch

Terminal 15 and 2 on the timer

Wire 47 on the contactor coil and 25 on the electronic circuit board

Connect one voltmeter probe to wire 47 on the contactor coil and the other to the following wires in succession:

Wire 10 on the power switch,

Terminal 14 on the timer,

Wire 25 on the circuit board.

If an intermittent loss of voltage, or a low voltage condition, the cause must be determined and corrected.

SECTION F. CONTACTOR TESTS

If the contactor has line voltage on the coil but it is not picked up to close the power contacts, the coil is failed open and the contactor must be replaced.

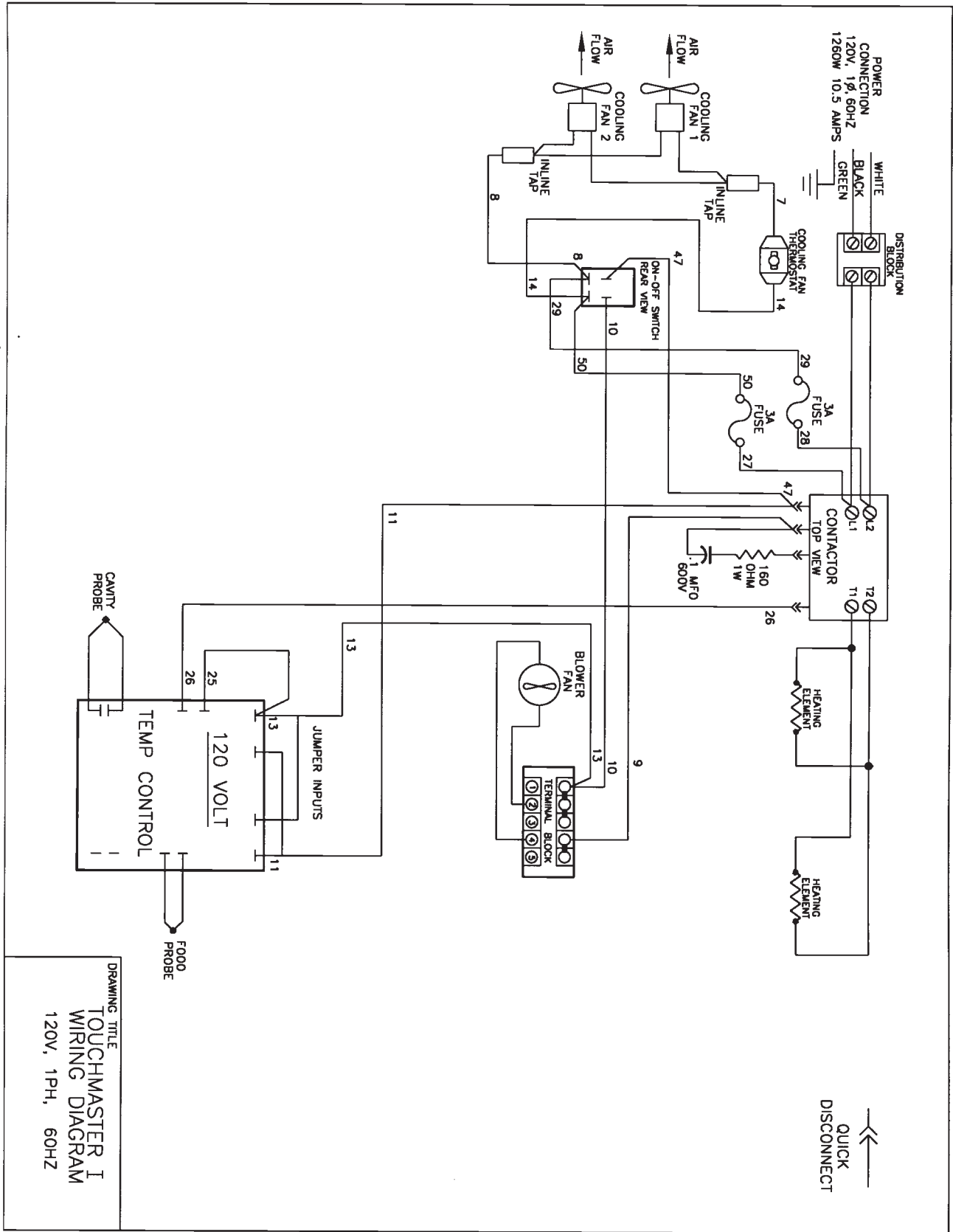

DRAWING TITLE
 TOUCHMASTER I
 WIRING DIAGRAM
 120V, 1PH, 60HZ



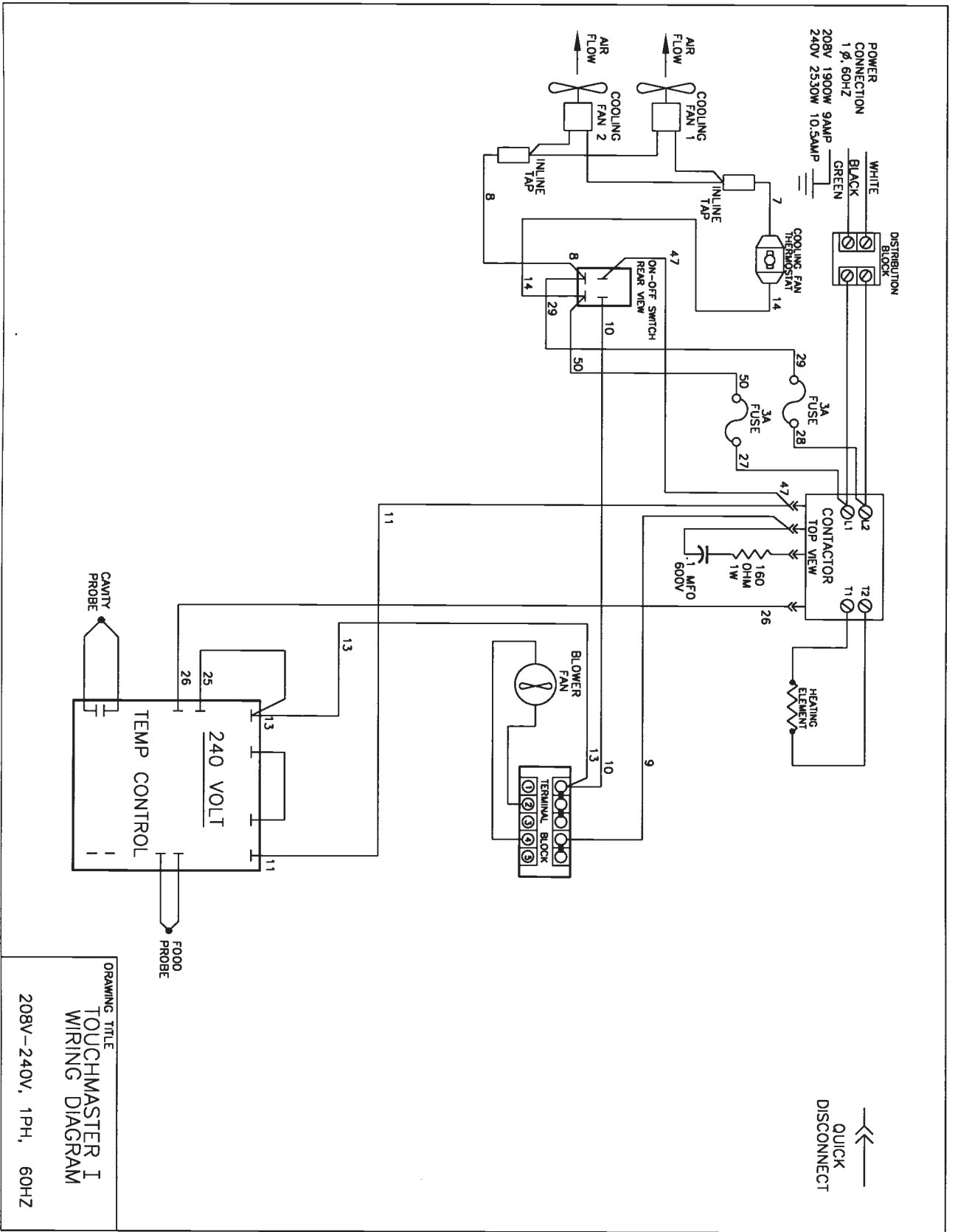

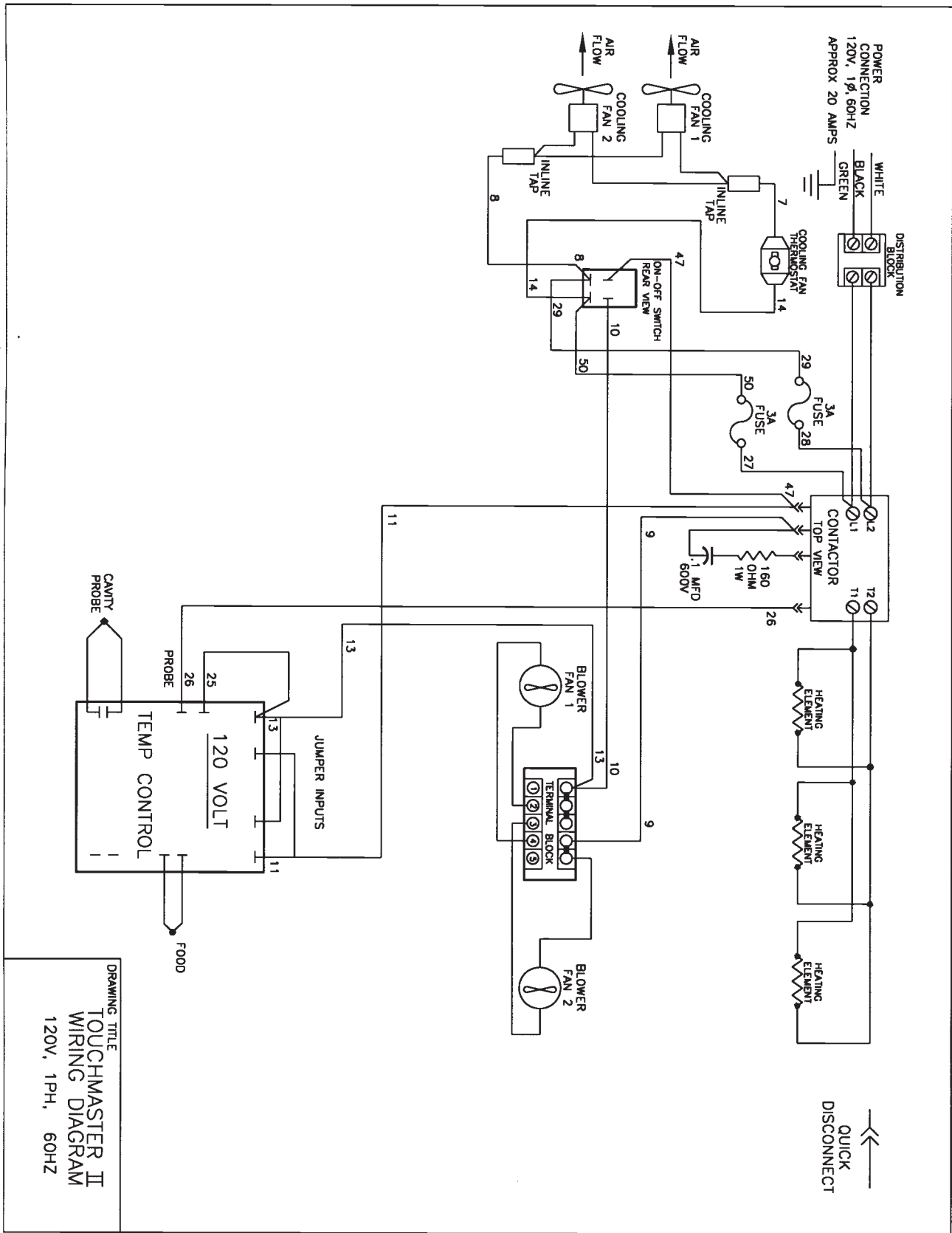

DRAWING TITLE
TOUCHMASTER II
 WIRING DIAGRAM
 120V, 1PH, 60HZ



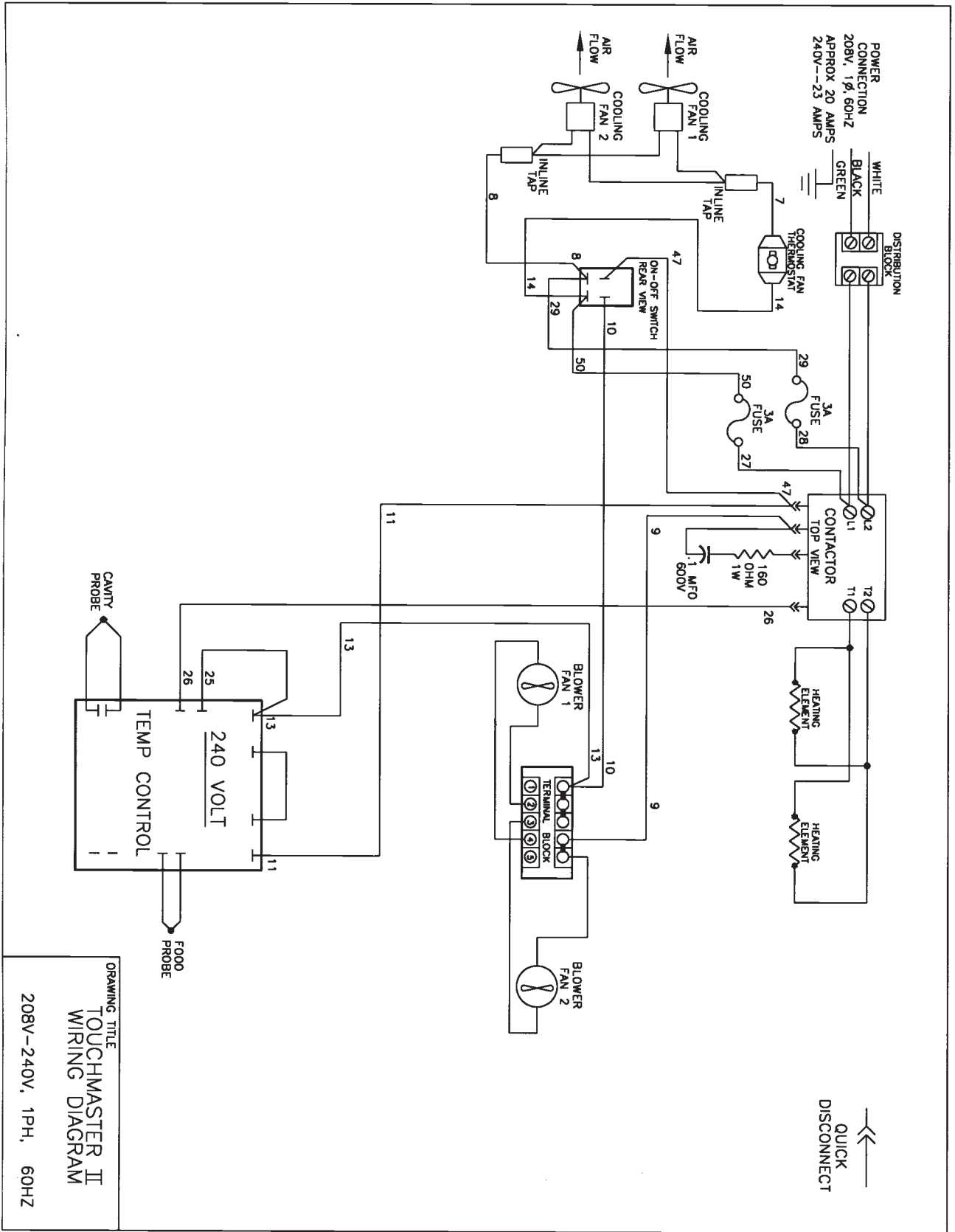

DRAWING TITLE
TOUCHMASTER II
WIRING DIAGRAM

208V-240V, 1PH, 60HZ



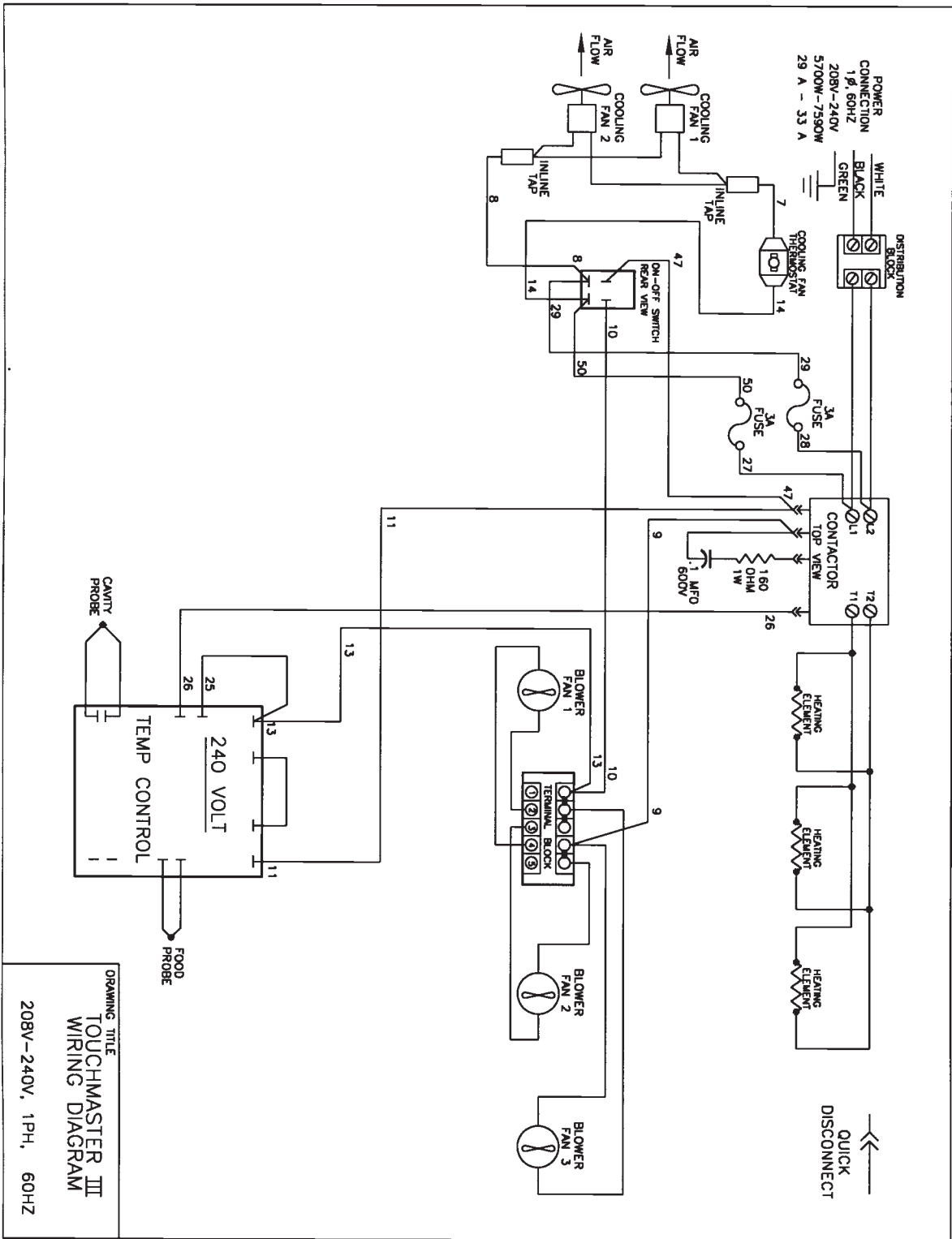

**WITTCO FOODSERVICE EQUIPMENT INC.
REPLACEMENT PARTS LIST**

WITTCO SERIES - TOUCHMASTER OVENS

6/18/98

WITTCO PART NO.	PART DESCRIPTION	MODEL NUMBER AND QUANTITY REQUIRED			
		TM-I	TM-II	TM-III	TM-IV
AD-301-1000-0	BLOWER MOTOR REPLACEMENT KIT 110 VOLT	1	2	3	4
AD-301-2000-0	BLOWER MOTOR REPLACEMENT KIT 208-240 VOLT	1	2	3	4
AD-266-0000-0	BLOWER MOTOR RETURN AIR GRATE	1	1	1	2
AD-254-1000-0	BULK HEAD CONNECTOR	1	1	1	2
WP-114-5R	CASTER, 5" HEAVY DUTY RIGID	2	2	2	2
WP-114-5S	CASTER, 5" HEAVY DUTY SWIVEL W/BRAKE	2	2	2	2
AD-260-4000-0	CONTACTOR - 2 POLE / 110 VOLT	1	1	1	2
AD-260-2000-0	CONTACTOR - 2 POLE / 208-240 VOLT	1	1	1	2
AD-260-3000-0	CONTACTOR - 3 POLE / 208-240 VOLT (3PHASE)	1	1	1	2
AD-264-0000-0	CONTROL TOP MODULE COVER	1	1	1	2
AD-254-2000-0	CONTROL PANEL DECAL (BLACK)	1	1	1	2
AD-254-2000-1	CONTROL PANEL WITH BLACK DECAL	1	1	1	2
AD-247-3000-0	CONTROLLER	1	1	1	2
AD-161-2000-0	CORD, 6FT. 208-240 VOLT (NO PLUG)	1	1		2
AD-161-3000-0	CORD, 6FT. 208-240 VOLT (NO PLUG) (TM-III ONLY)			1	
AD-161-1000-0	CORD, 6FT. 120 VOLT (NO PLUG)	1	1	1	2
AD-265-0000-0	DIVIDER BAR (FOR TM-III ONLY)			1	
AD-263-1000-0	DOOR, (NO HARDWARE)	1			
AD-263-2000-0	DOOR, (NO HARDWARE)		1		2
AD-263-3000-0	DOOR, (NO HARDWARE)			2	
AD-134-1000-0	DOOR CATCH ONLY (NO HANDLE)	1	1	2	2
AD-134-0000-0	DOOR LATCH COMPLETE W/CATCH	1	1	2	2
AD-280-1000-0	ELEMENT, 1900 WATT 120 VOLT	2	3	N/A	6
AD-280-1000-0	ELEMENT, 1900 WATT 208-240	1	2	3	4
AD-305-1000-0	FAN, COOLING MOTOR 120 VOLT	2	2	2	4
AD-305-2000-0	FAN, COOLING MOTOR 208-240 VOLT	2	2	2	4
AD-253-0000-0	FAN SCREEN FOR COOLING MOTOR	2	2	2	4
AD-210-0000-0	FUSE HOLDER	2	2	2	4

WITCO PART NO.	PART DESCRIPTION	MODEL NUMBER AND QUANTITY REQUIRED			
		TM-I	TM-II	TM-III	TM-IV
AD-207-0000-0	FUSE, 3 AMP	2	2	2	4
AD-142-750-E	GASKET, DOOR ALUMINUM EXTRUSION	1			
AD-142-1000-E	GASKET, DOOR ALUMINUM EXTRUSION		1		2
AD-142-1200-E	GASKET, DOOR ALUMINUM EXTRUSION			2	
WP-302	GASKET, DOOR (BLACK) BY THE FT.	8'	11'	21'	21'
AD-142-HI'	GASKET, HOT TOP / ORANGE	1	1	1	2
WP-111	HINGE, DOOR	2	2	4	4
AD-310-0000-0	LATCH, SPRING LOADED (INCLUDES BOLTS FOR HOT TOP)	4	4	4	8
AD-246-1000-0	PROBE, AIR	1	1	1	2
AD-246-2000-0	PROBE, MEAT	1	1	1	2
AD-261-5000-0	RACKS, INT. SIDE	2			
AD-261-2000-0	RACKS, INT. SIDE		2		4
AD-261-3000-0	RACKS, INT. SIDE			4	
WP-305	RACK, SIDE RETAINING BOLTS	8	8	16	16
AD-252-0000-0	STRAIN RELIEF AT POWER CORD	1	1	1	2
AD-135-0000-0	SUPPRESSOR (ORANGE)	1	1	1	2
AD-212-1000-0	SWITCH, START PUSH BUTTON (RED)	1	1	1	2
AD-206-2000-0	TERMINAL BLOCK, INTERNAL DISTRIBUTION	1	1	1	2
AD-206-1000-0	TERMINAL BLOCK - POWER CONNECT	1	1	1	2
AD-241-1000-0	THERMOSTAT, HI LIMIT	1	1	1	2
AD-251-0000-0	THERMOSTAT FOR FAN COOLING MOTOR	1	1	1	2
AD-267-1000-0	TUNNEL, AIR FLOW	1			
AD-267-2000-0	TUNNEL, AIR FLOW		1		2
AD-267-3000-0	TUNNEL, AIR FLOW			2	

- NOTES -

- NOTES -

- NOTES -

