



WELLS BLOOMFIELD, LLC
2 ERIK CIRCLE, P. O. Box 280 Verdi, NV 89439
telephone: 775-689-5703
fax: 775-689-5976
www.wellsbloomfield.com

019

OWNERS MANUAL

Built-In Hotplate MODEL H-006UL

Includes
**INSTALLATION
USE & CARE
PARTS LIST**

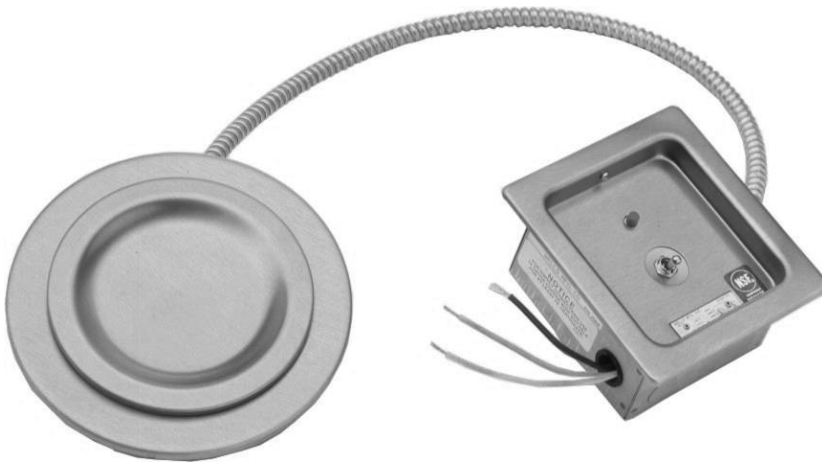

Model H-006UL

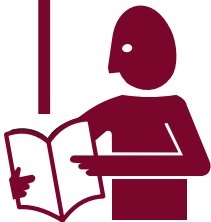

IMPORTANT: DO NOT DISCARD THIS MANUAL

This manual is considered to be part of the appliance and is to be given to the OWNER or MANAGER of the restaurant, or to the person responsible for TRAINING OPERATORS of this appliance. Additional manuals are available from your WELLS DEALER.

THIS MANUAL MUST BE READ AND UNDERSTOOD BY ALL PERSONS USING OR INSTALLING THIS APPLIANCE. Contact your WELLS DEALER if you have any questions concerning installation, operation or maintenance of this equipment.

PRINTED IN UNITED STATES OF AMERICA

LIMITED WARRANTY STATEMENT

Unless otherwise specified, all commercial cooking equipment manufactured by WELLS BLOOMFIELD, LLC is warranted against defects in materials and workmanship for a period of one year from the date of original installation or 18 months from the date of shipment from our factory, whichever comes first, and is for the benefit of the original purchaser only.

THIS WARRANTY IS THE COMPLETE AND ONLY WARRANTY, EXPRESSED OR IMPLIED IN LAW OR IN FACT, INCLUDING BUT NOT LIMITED TO, WARRANTIES OF MERCHANTABILITY OR FITNESS FOR ANY PARTICULAR PURPOSE, AND/OR FOR DIRECT, INDIRECT OR CONSEQUENTIAL DAMAGES IN CONNECTION WITH WELLS BLOOMFIELD PRODUCTS. This warranty is void if it is determined that, upon inspection by an authorized service agency, the equipment has been modified, misused, misapplied, improperly installed, or damaged in transit or by fire, flood or act of God. It also does not apply if the serial nameplate has been removed, or if service is performed by unauthorized personnel. The prices charged by Wells Bloomfield for its products are

based upon the limitations in this warranty. Seller's obligation under this warranty is limited to the repair of defects without charge by a Wells Bloomfield factory authorized service agency or one of its sub-service agencies. This service will be provided on customer's premises for non-portable models. Portable models (a device with a cord and plug) must be taken or shipped to the closest authorized service agency, transportation charges prepaid, for service. In addition to restrictions contained in this warranty, specific limitations are shown in the Service Policy and Procedure Guide. Wells Bloomfield authorized service agencies are located in principal cities. This warranty is valid in the United States and Canada and void elsewhere. Please consult your classified telephone directory, your foodservice equipment dealer or contact:

**Service Department, Wells Bloomfield, LLC
P.O. Box 280, Verdi, Nevada 89439
phone (775) 689-5707 or fax (775) 689-5976**

for information and other details concerning warranty.

SERVICE POLICY AND PROCEDURE GUIDE and ADDITIONAL WARRANTY EXCLUSIONS

1. Resetting of safety thermostats, circuit breakers, over load protectors, and/or fuse replacements are **not** covered by this warranty unless warranted conditions are the cause.
2. All problems due to operation at **voltages or phase other than specified on equipment nameplates** are **not** covered by this warranty. Conversion to correct voltage and/or phase must be the customer's responsibility.
3. All problems due to **electrical connections not made in accordance with electrical code requirements and wiring diagrams** supplied with the equipment are **not** covered by this warranty.
4. Replacement of items **subject to normal wear**, to include such items as knobs, light bulbs; and, normal maintenance functions including adjustments of thermostats, adjustment of micro switches and replacement of fuses and indicating lights are **not** covered by warranty.
5. Damage to electrical cords and/or plug due to exposure to excessive heat are **not** covered by this warranty.
6. Full use, care, and maintenance instructions supplied with each machine. Noted maintenance and preventative maintenance items, such as servicing and cleaning schedules, are customer responsibility. Those miscellaneous adjustments noted are customer responsibility. Proper attention to preventative maintenance and scheduled maintenance procedures will prolong the life of the appliance.
7. Travel mileage is limited to **sixty (60) miles** from an Authorized Service Agency or one of its sub-service agencies.
8. All labor shall be performed during regular working hours. Overtime premium will be charged to the buyer.
9. All genuine Wells replacement parts are warranted for ninety (90) days from date of purchase on non-warranty equipment. This parts warranty is limited only to replacement of the defective part(s). **Any use of non-genuine Wells parts completely voids any warranty.**
10. Installation, labor, and job check-outs are **not** considered warranty and are thus **not** covered by this warranty.
11. Charges incurred by delays, waiting time or operating restrictions that hinder the service technician's ability to perform service are **not** covered by warranty. This includes institutional and correctional facilities.

SHIPPING DAMAGE CLAIM PROCEDURE

NOTE: For your protection, please note that equipment in this shipment was carefully inspected and packaged by skilled personnel before leaving the factory. Upon acceptance of this shipment, the transportation company assumes full responsibility for its safe delivery.

IF SHIPMENT ARRIVES DAMAGED:

1. **VISIBLE LOSS OR DAMAGE:** Be certain that any visible loss or damage is noted on the freight bill or express receipt, and that the note of loss or damage is signed by the delivery person.
2. **FILE CLAIM FOR DAMAGE IMMEDIATELY:** Regardless of the extent of the damage.

3. **CONCEALED LOSS OR DAMAGE:** if damage is unnoticed until the merchandise is unpacked, notify the transportation company or carrier immediately, and file "CONCEALED DAMAGE" claim with them. This should be done within fifteen (15) days from the date the delivery was made to you. Be sure to retain the container for inspection.

Wells Bloomfield cannot assume liability for damage or loss incurred in transit. We will, however, at your request, supply you with the necessary documents to support your claim.

TABLE OF CONTENTS

WARRANTY	xi
SPECIFICATIONS	1
FEATURES & OPERATING CONTROLS	2
PRECAUTIONS & GENERAL INFORMATION	3
AGENCY LISTING INFORMATION	3
INSTALLATION	4
OPERATION	5
CLEANING INSTRUCTIONS	5
EXPLODED VIEW AND PARTS LIST	6
PARTS & SERVICE	7
CUSTOMER SERVICE DATA	7

INTRODUCTION

Thank You for purchasing this Wells Bloomfield appliance.

Proper installation, professional operation and consistent maintenance of this appliance will ensure that it gives you the very best performance and a long, economical service life.

This manual contains the information needed to properly install this appliance, and to use and care for the appliance in a manner which will ensure its optimum performance.

SPECIFICATIONS

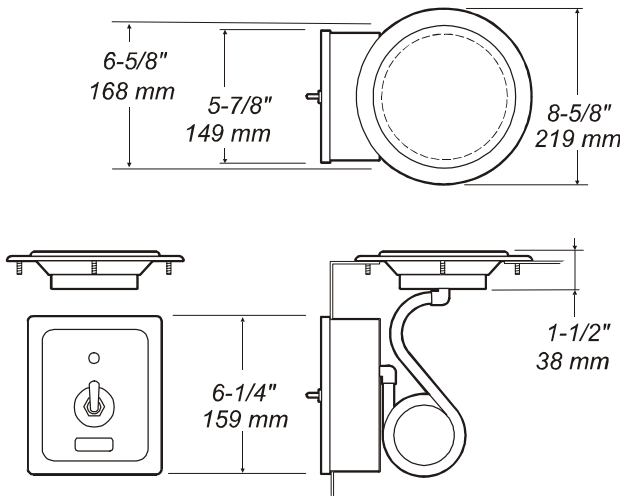

MINIMUM CLEARANCES REQUIRED UNIT-TO-NEAREST SURFACE

BACK	SIDE	BOTTOM*	FRONT**
1" 25 mm	1" 25 mm	8" 203 mm	2-1/4" 57"

* If storage is to be used beneath unit, a baffle must be placed 8" beneath the hotplate to prevent contact.

** Front of counter to cutout.
If control box is placed directly beneath the hotplate, clearance may be 1".

ELECTRICAL SPECIFICATIONS

MODEL	VOLTS	WATTS	AMPS	FIELD WIRING
H-006UL	120 VAC 1 ϕ	70	0.6	2 wire (L1, Neutral) + Gnd 14 AWG Copper 90°C

019 p/n 305816 OwM H-006UL

FEATURES & OPERATING CONTROLS

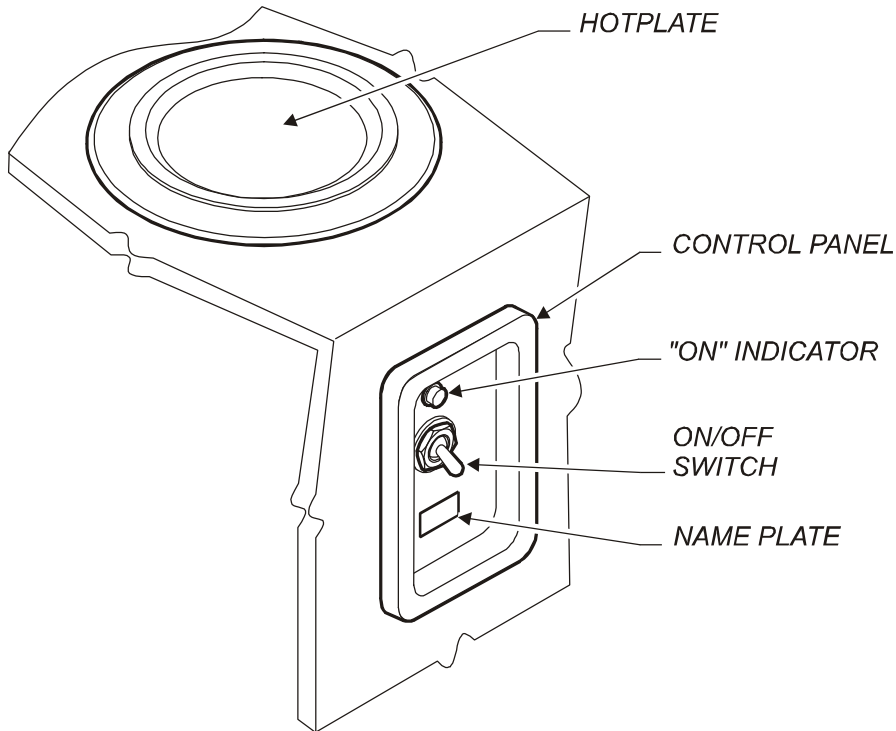

Fig 1. H-006UL Features and Operating Controls

019 p/h 305816 OWM/H-006UL

ITEM	DESCRIPTION
CONTROL PANEL	Mounted to front of counter. Toggle switch controls power. Indicator glows when power is "ON".
HOTPLATE	Mounts to top of counter. Top surface is hot when "ON". Bowl-shaped to position and hold containers.
"ON" INDICATOR	Light mounted in control panel. Glows red when power is "ON".
ON/OFF SWITCH	Toggle switch mounted in control panel. "UP" position turns power to hotplate "ON".
NAME PLATE	Mounted on control panel. Lists manufacturer data, model and serial number, voltage and wattage of unit.

PRECAUTIONS AND GENERAL INFORMATION

This appliance is intended for use in commercial establishments only.

This appliance is intended to hold pre-heated beverage at temperature for human consumption. No other use is recommended or authorized by the manufacturer or its agents.

Operators of this appliance must be familiar with the appliance use, limitations and associated restrictions. Operating instructions must be read and understood by all persons using or installing this appliance.

Cleanliness of this appliance is essential to good sanitation. Read and follow all included cleaning instructions and schedules to ensure the safety of the food product.

Disconnect this appliance from electrical power before performing any maintenance or servicing.

This appliance is not jet stream approved. DO NOT direct water jet or steam jet at this appliance, or at any control panel or wiring. DO NOT splash or pour water on, in or over any controls, control panel or wiring.

Hotplate surfaces will be very hot when in use. Contact will cause severe injury.

The technical content of this manual, including any wiring diagrams, schematics, parts breakdown illustrations and/or adjustment procedures, is intended for use by qualified technical personnel.

Any procedure which requires the use of tools must be performed by a qualified technician.

This manual is considered to be a permanent part of the appliance. This manual and all supplied instructions, diagrams, schematics, parts breakdown illustrations, notices and labels must remain with the appliance if it is sold or moved to another location.

This appliance is made in the USA. Unless otherwise noted, this appliance has American sizes on all hardware.



WARNING: ELECTRIC SHOCK HAZARD

All servicing requiring access to non-insulated electrical components must be performed by a factory authorized technician. DO NOT open any access panel which requires the use of tools. Failure to follow this warning can result in severe electrical shock.



CAUTION: RISK OF DAMAGE

DO NOT connect or energize this appliance until all installation instructions are read and followed. Damage to the appliance will result if these instructions are not followed.



CAUTION: HOT SURFACE

Exposed surfaces can be hot to the touch and may cause burns.

019 p/n 305816 OWM H-006UL

AGENCY LISTING INFORMATION

This appliance conforms to NSF Standard 4 for sanitation only if installed in accordance with the supplied *Installation Instructions* and maintained according to the instructions in this manual.

This appliance is  Listed under UL File E6070 for 120V.

This appliance is  Listed under UL File E6070 for 120V .



STD 4



E6070



E6070

INSTALLATION

NOTE: DO NOT discard the carton or other packing materials until you have inspected the appliance for hidden damage and tested it for proper operation. Refer to *SHIPPING DAMAGE CLAIM PROCEDURE* on the inside front cover of this manual.



WARNING: RISK OF PERSONAL INJURY

Installation procedures must be performed by a qualified technician with full knowledge of all applicable electrical and plumbing codes. Failure can result in personal injury and property damage.



CAUTION: RISK OF DAMAGE

DO NOT connect or energize this appliance until all installation instructions are read and followed. Damage to the appliance will result if these instructions are not followed.



CAUTION: ELECTRICAL SHOCK HAZARD

The ground screw of this appliance must be connected to a suitable building ground.

IMPORTANT:

Contact a licensed electrician to install and connect electrical power to the appliance.

IMPORTANT:

Damage due to being connected to the wrong voltage or phase is NOT covered by warranty.

UNPACKING & INSPECTION

Carefully remove the appliance from the carton. Remove all protective plastic film, packing materials and accessories from the Appliance before connecting electrical power or otherwise performing any installation procedure.

Carefully read all instructions in this manual and the *Installation Instruction Sheet* packed with the appliance before starting any installation.

Read and understand all labels and diagrams attached to the appliance.

Carefully account for all components and accessories before discarding packing materials. Store all accessories in a convenient place for later use.

SETUP

Refer to the *Installation Instruction Sheet* for cutout dimensions and required clearances. Maintain required clearances between the appliance and adjacent surfaces.

Unit must be installed such that it can be serviced from the bottom.

If the area beneath is to be used storage, a baffle must be placed 8" beneath the hotplate to prevent contact with elevated temperatures.

Provided gaskets for hotplate, hotplate adapter ring and control panel must be used in this installation. Damage caused by failure to use these gaskets is not covered by warranty.

ELECTRICAL INSTALLATION

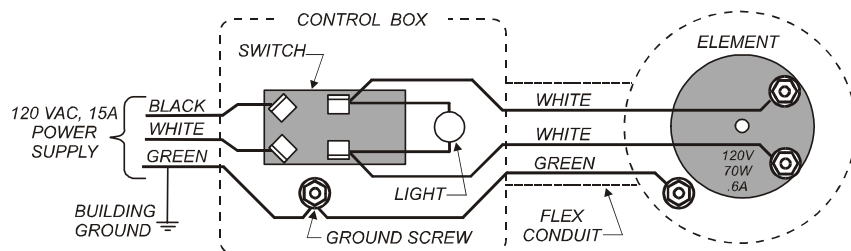

Fig. 2 H-006UL Wiring Diagram

Electrical flex-conduit is provided to allow the hotplate to be located up to 32" from the control panel. Excess conduit must be coiled and secured to prevent damage. DO NOT cut the conduit or wiring. Unauthorized alteration of the conduit or wiring voids the warranty and UL listing.

Connect field wiring to provided pigtail with wire nuts (not provided).

OPERATION

PREPARATION

1. Examine hotplate and control panel for condition before turning the ON/OFF SWITCH "ON". Clean as necessary before use.
2. Turn the ON/OFF SWITCH "ON" and allow the hotplate to pre-heat for 15 minutes before use .

USE

1. Set the container of pre-heated beverage on the hotplate. The heating surface of the hotplate is bowl-shaped to safely hold curved-bottom containers, specifically standard coffee decanters.
2. DO NOT allow the container to run dry. Remove empty containers from hotplate immediately and allow to cool before reuse.

IMPORTANT:

Avoid storing flammable or combustible materials in, on or near the appliance.



**CAUTION:
HOT SURFACE**

Exposed surfaces can be hot to the touch and may cause burns.



**CAUTION:
ELECTRICAL
SHOCK HAZARD**

DO NOT splash or pour water onto control panel or wiring.

CLEANING INSTRUCTIONS

PRECAUTIONS: Turn switch *OFF* and allow to cool before cleaning.

FREQUENCY: Daily

TOOLS: Soft Cloth or Sponge, Mild Detergent,
Plastic Scouring Pad



**CAUTION:
HOT SURFACE**

Exposed surfaces can be hot to the touch and may cause burns. Allow to cool before cleaning.



**CAUTION:
ELECTRICAL
SHOCK HAZARD**

DO NOT splash or pour water onto control panel or wiring.

1. Remove containers from hotplates. Turn ON/OFF SWITCH "OFF". Allow hotplate to cool completely before cleaning.
2. Wipe hotplate with a soft cloth or sponge moistened with water and mild detergent.
3. Use a plastic scouring pad to remove any hardened food particles or mineral deposits. Rub only in the direction of the visible grain lines.
4. Rinse hotplate by wiping with a soft cloth or sponge moistened with water.
5. Wipe control panel with a soft cloth or sponge moistened with water.

Procedure is complete

IMPORTANT: DO NOT use steel wool for cleaning.

Keep your stainless steel hotplate clean and free from calcium buildup:

- Use alkaline, alkaline chlorinated or non-chloride cleanser.
- Use citric acid-based cleaners to remove calcium deposits.

EXPLODED VIEW AND PARTS LIST

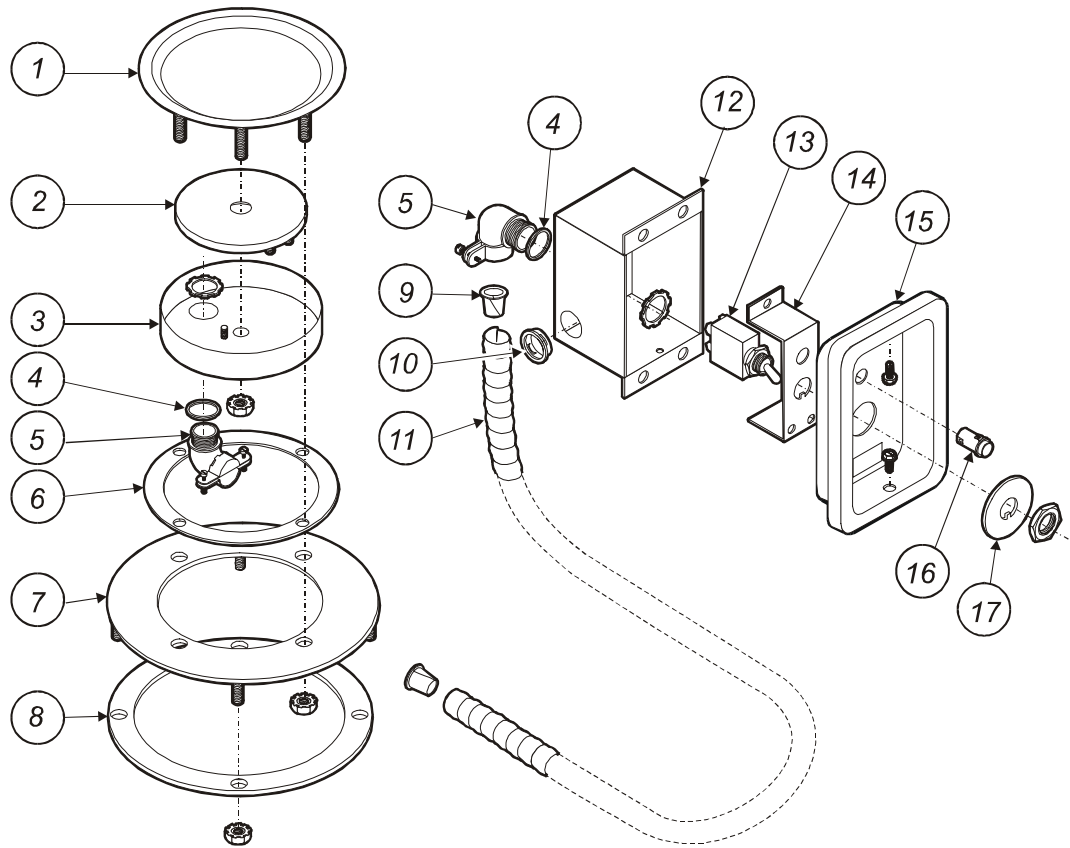

ITEM	P/N	DESCRIPTION	QTY
1	50413	COFFEE WELL, STAINLESS STEEL	1
2	502459	ELEMENT 120V 70W H006	1
3		COVER, ELEMENT H006	1
4	50177	FIBER WASHER	2
5	8706-109	FITTING FLEX CONDUIT 3/8" x 90°	2
6	50416	GASKET, WARMER PLATE	1
7		PLATE, ADAPTER H006	1
8	51647	GASKET COFFEE WARMER	1
9		INSULINER, 3/8" FLEX	2
10	51040	BUSHING HEYCO7/8" O.D.	1
11		FLEX CONDUIT 3/8" x 37-1/4"	1
12	60846	BOX CONTROL MOD100T	1
13	50169	SWITCH DPST 120V	1
14		BRACKET SWITCH MOUNTING	1
15	51023	CONTROL PANEL H336	1
16	50385	LIGHT SIGNAL RED 240V PUSH-ON TERMINALS	1
17	502461	COVER SWITCH HOLE	1
NOT SHOWN	502850	GASKET URETHANE CONTROL PANEL 1/4" x 3/8" x 22"	1

019 p/n 305816 OWM/H-006UL

ACCESSORY

There are no accessories for this unit at this time

PART NO.

IMPORTANT: Use only factory authorized service parts and replacement filters.

For factory authorized service, or to order factory authorized replacement parts, contact your Wells authorized service agency, or call:

Wells Bloomfield, LLC

2 Erik Circle
P. O. Box 280
Verdi, NV 89439

Service Parts Dept.
phone: (775) 689-5707
fax: (775) 689-5976

Service Parts Department can supply you with the name and telephone number of the **WELLS AUTHORIZED SERVICE AGENCY** nearest you.

CUSTOMER SERVICE DATA

please have this information available if calling for service

RESTAURANT _____ LOCATION _____
INSTALLATION DATE _____ TECHNICIAN _____
SERVICE COMPANY _____
ADDRESS _____ STATE _____ ZIP _____
TELEPHONE NUMBER (____) _____ - _____

EQUIPMENT MODEL NO. _____
EQUIPMENT SERIAL NO. _____
VOLTAGE: (check one) 120

019 p/n 305816 OWM H-006UL



Wells Bloomfield proudly supports CFESA
Commercial Food Equipment Service Association

SERVICE TRAINING - QUALITY SERVICE



CUSTOMER SATISFACTION



WELLS BLOOMFIELD, LLC
2 ERIK CIRCLE, P. O. Box 280 Verdi, NV 89439
telephone: 775-689-5703
fax: 775-689-5976
www.wellsbloomfield.com

PRINTED IN UNITED STATES OF AMERICA