 a **Standex** company

FEDERAL INDUSTRIES

**C-STORE NON-REFRIGERATED
SELF-SERVE DISPLAY CASE
WDC-42 AND CT-42**

**INSTALLATION AND SERVICE
INSTRUCTIONS**

FEDERAL INDUSTRIES
Toll Free 1 (800) 356-4206

215 Federal Avenue
WI Phone (608) 424-3331

Belleville, Wisconsin 53508
Fax (608) 424-3234

TABLE OF CONTENTS

INTRODUCTION	2
WARNING LABELS AND SAFETY INSTRUCTIONS	3
PRE-INSTALLATION INSTRUCTIONS	4
INSTALLATION INSTRUCTIONS	4
Leveling the Cabinet	4
Shelf Placement	5
Care and Cleaning	5
Electrical Information and Grounding	5
SERVICE INFORMATION	6
Door Removal	6
Special Service Situations	7
SALE AND DISPOSAL	8
WIRING DIAGRAM	9
REPLACEMENT PARTS	10

INTRODUCTION

Thank you for purchasing a Federal Industries cabinet. This manual contains important instructions for installing, using and servicing Federal equipment. A parts list and assembly drawings are also included in this manual. Read all these documents carefully before installing or servicing your equipment.

NOTICE

Read this manual before installing your cabinet. Keep the manual and refer to it before doing any service on the equipment. Failure to do so could result in personal injury or damage to the cabinet.

NOTICE

Installation and service of the electrical components of the cabinet must be performed by a licensed electrician.

The portions of this manual covering electrical components contain technical instructions intended only for persons qualified to perform electrical work.

DANGER

Improper or faulty hook-up of electrical components of the cabinet can result in severe injury or death.

All electrical wiring hook-ups must be done in accordance with all applicable local, regional or national standards.

This manual cannot cover every installation, use or service situation. If you need additional information, call or write us:

**Customer Service Department
Federal Industries
215 Federal Avenue
Belleville, WI 53508
Toll Free 1 (800) 356-4206
WI Phone (608) 424-3331**

1. WARNING LABELS AND SAFETY INSTRUCTIONS



This is the safety-alert symbol. When you see this symbol on your cabinet or in this manual, be alert to the potential for personal injury or damage to your equipment.

Be sure you understand all safety messages and always follow recommended precautions and safe operating practices.



NOTICE TO EMPLOYERS

You must make sure that everyone who installs, uses or services your cabinet is thoroughly familiar with all safety information and procedures.

Important safety information is presented in this section and throughout the manual. The following signal words are used in the warnings and safety messages:

DANGER: Severe injury or death will occur if you ignore the message.

WARNING: Severe injury or death can occur if you ignore the message.

CAUTION: Minor injury or damage to your cabinet can occur if you ignore the message.

NOTICE: This is important installation, operation or service information. If you ignore the message, you may damage your cabinet.

The warning and safety labels shown throughout this manual are placed on your Federal Industries cabinet at the factory. Follow all warning label instructions. If any warning or safety labels become lost or damaged, call our customer service department at 1 (800) 356-4206 for replacements.

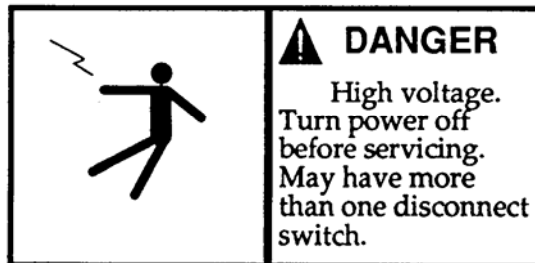

This label is located on the ballast box cover. The WDC-42 ballasts are located in the bottom storage area at the rear of the compartment. The ballasts for the CT-42 are mounted on the back of the cabinet.

2. PRE-INSTALLATION INSTRUCTIONS

Inspection for Shipping Damage

You are responsible for filing all freight claims with the delivering truck line. Inspect all cartons and crates for damage as soon as they arrive. If damage is noted to shipping crates or cartons or if a shortage is found, note this on the bill of lading (all copies) prior to signing.

If damage is discovered when the cabinet is uncrated, immediately call the delivering truck line and follow up the call with a written report indicating concealed damage to your shipment. Ask for an immediate inspection of your concealed damage item. Crating material must be retained to show the inspector from the truck line.

3. INSTALLATION INSTRUCTIONS

Leveling the Cabinet

Your Federal cabinet should be level for the best operating results. The cabinet can be leveled by placing metal shims under the base.

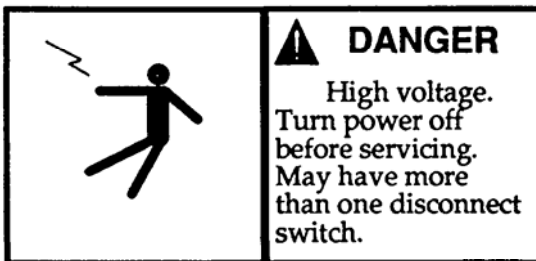

This label is located on the ballast box cover.

NOTICE

Improper or faulty hook-up of electrical components of the cabinet can result in severe injury or death.

Installation of the cabinet electrical components must be performed only by a licensed electrician.

All electrical wiring hook-ups must be done in accordance with all applicable local, regional or national standards.

Shelf Placement

The WDC-42 and CT-42 Display Cases come standard with four tiers of shelves. The shelf support brackets are installed at the factory. All that is necessary is to hang the shelves onto the shelf support brackets. The shelf support brackets can be adjusted up or down if a different spacing is desired.

Care and Cleaning

Surfaces and glass may be cleaned using a moist cloth and mild cleansers.

Electrical Information and Grounding

This information is for cases ordered with the optional light package.

The Federal cabinet must be wired to a 115 VAC, 60 HZ, 1 Phase and 15 AMP power supply. Copper wire only must be used for the power supply connection. This unit is designed for permanent connection to power source. The electrical service must be grounded upon installation. A grounding lug is supplied. The lug is located in the electrical box, which is located in the back of the cabinet. The lug is identified with a "GROUND" label.

The light switch for the WDC-42 is located in the lower storage compartment. The switch is on the right side mounted on the ceiling.

For the CT-42, the switch is located on the back of the case near the bottom right corner.

4. SERVICE INFORMATION

TO REMOVE SELF-CLOSING DOORS

- SLOTS FOR DISENGAGING THE DOOR ROLLERS ARE PROVIDED AT THE CENTER OF THE TOP DOOR TRACK.
- SLIDE THE RIGHT HAND DOOR TO THE CENTER OF THE DOOR OPENING. LIFT THE DOOR UP OFF THE ROLLER TRACK. SWING THE BOTTOM OF THE DOOR SEVERAL INCHES OUT OF THE BOTTOM TRACK & LOWER THE DOOR OUT OF THE TOP TRACK.

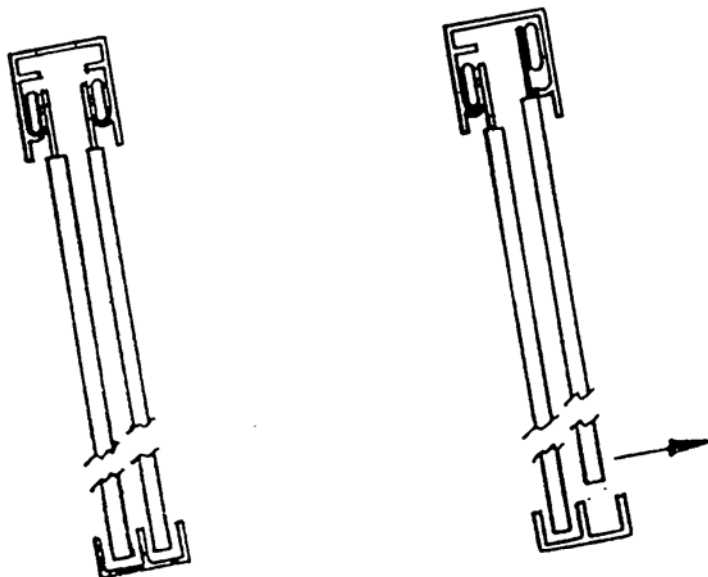

TO REMOVE THE DOOR CLOSING SPRING, GRASP THE SPRING SEVERAL INCHES FROM THE END AND SLIP THE SPRING END LOOP OFF THE CLIP LOCATED IN THE UPPER CHANNEL.

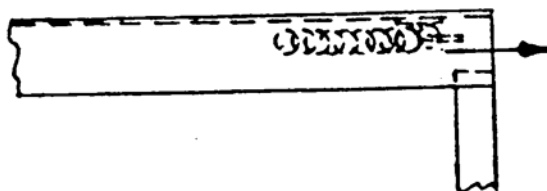

REMOVE THE LEFT HAND DOOR IN THE SAME MANNER.

TO INSTALL THE DOORS, REVERSE THIS PROCEDURE. THE DOOR CLOSING SPRING MUST BE IN FRONT OF THE ROLLERS ON THE LEFT HAND INSIDE DOOR & BEHIND THE ROLLERS ON THE RIGHT HAND OUTSIDE DOOR.

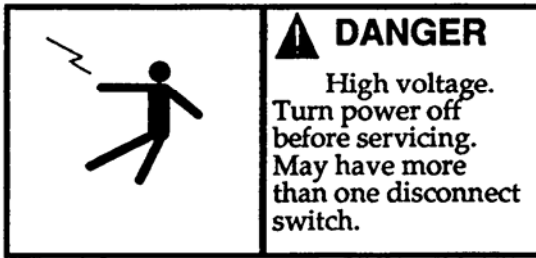

Before any service work is performed on the cabinet, make sure all power is disconnected to the cabinet.

Service problems or request for repair parts from authorized service agencies, trained service personnel or owners should be referred to:

Customer Service Dept.
Federal Industries
215 Federal Avenue
Belleville, WI 53508

Toll Free: 1 (800) 356-4206
WI Number: 1 (608) 424-3331

When corresponding with the factory, refer to the case serial number. The serial number is located on the interior mirror, upper left corner.

Special Service Situations

If moisture or liquid is observed around or under a Federal Industries cabinet, an immediate investigation should be made by qualified personnel to determine the source of the moisture or liquid. The investigation made should determine if the cabinet is malfunctioning or if there is a simple housekeeping problem.

Moisture or liquid around or under a cabinet is a potential slip/fall hazard for persons walking by or working in the general area of the cabinet.

Any cabinet malfunction or housekeeping problem that creates a slip/fall hazard around or under a cabinet should be corrected immediately.

5. SALE AND DISPOSAL

Owner Responsibility

If you sell or give away your Federal Industries cabinet you must make sure that all safety labels and the Installation - Service Manual are included with it. If you need replacement labels or manuals, Federal Industries will provide them free. Contact the customer service department at Federal Industries at 1 (800) 356-4206.

The customer service department at Federal Industries should be contacted at the time of sale or disposal of your cabinet so records may be kept of its new location.

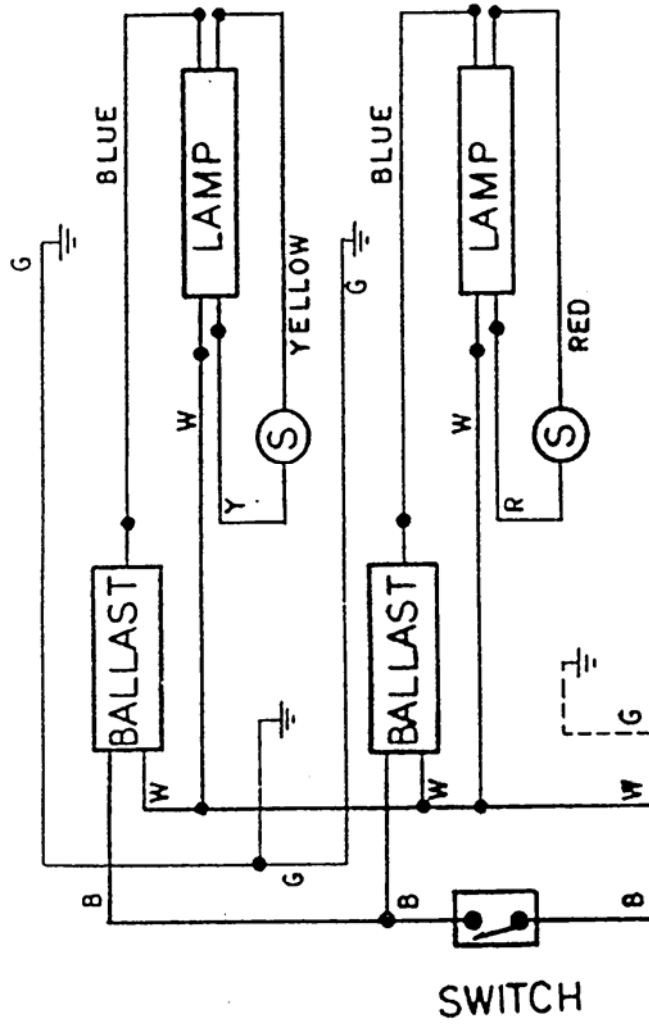

120V 60 HZ 1 PH
 UNIT MUST BE GROUNDED

REPLACEMENT PARTS FOR FEDERAL INDUSTRIES WDC-42 and CT-42

<u>PART DESCRIPTION</u>	<u>PART NUMBER</u>
Wire Shelf	63-30273
Shelf Bracket - Right Side	M-7823R
Shelf Bracket - Left Side	M-7823L
Top Glass	51-80233
End Glass	51-80234
Self-Closing Front Door Assembly	53-80153
Napkin Holder	** M-7801
Plexiglass Divider	** SA-0483
Door Glides	** 56-80269
Door Finger Pulls	** 66-10716
Ballast	* 39-30003
Lamp, F12T5CW	* 42-30218
Starter, FS4	* 39-30402
Light Switch	* 41-30804
Starter Holder	* 42-30612
Lamp Cover - 25"	* 42-30209
Lamp Holder	* 42-30611

* Cases with Optional Lights

** WDC-42 Only

TO REMOVE SELF-CLOSING DOORS

- SLOTS FOR DISENGAGING THE DOOR ROLLERS ARE PROVIDED AT THE CENTER OF THE TOP DOOR TRACK.
- SLIDE THE RIGHT HAND DOOR TO THE CENTER OF THE DOOR OPENING. LIFT THE DOOR UP OFF THE ROLLER TRACK. SWING THE BOTTOM OF THE DOOR SEVERAL INCHES OUT OF THE BOTTOM TRACK & LOWER THE DOOR OUT OF THE TOP TRACK.

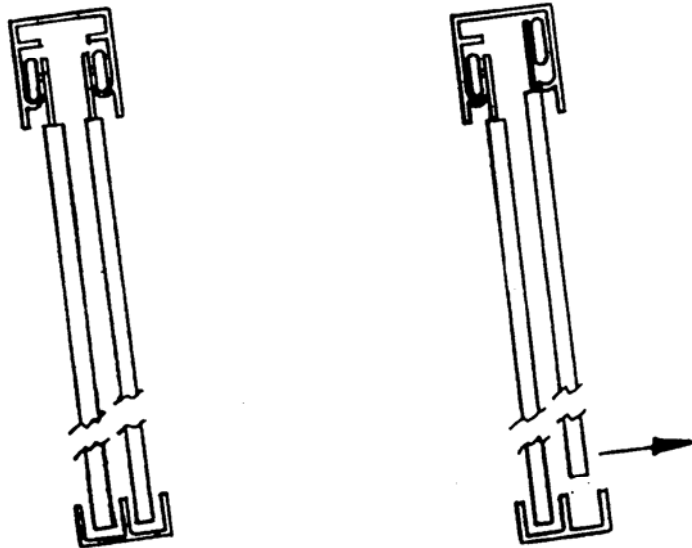

TO REMOVE THE DOOR CLOSING SPRING, GRASP THE SPRING SEVERAL INCHES FROM THE END AND SLIP THE SPRING END LOOP OFF THE CLIP LOCATED IN THE UPPER CHANNEL.

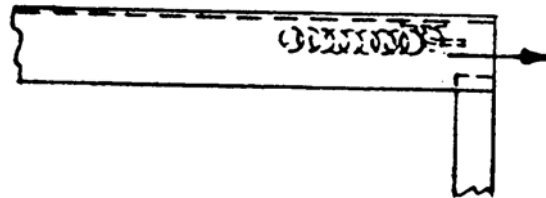

REMOVE THE LEFT HAND DOOR IN THE SAME MANNER.

TO INSTALL THE DOORS, REVERSE THIS PROCEDURE. THE DOOR CLOSING SPRING MUST BE IN FRONT OF THE ROLLERS ON THE LEFT HAND INSIDE DOOR & BEHIND THE ROLLERS ON THE RIGHT HAND OUTSIDE DOOR.

REPLACEMENT PARTS FOR WDC-42

<u>FEDERAL PART NO.</u>	<u>DESCRIPTION</u>
67-70349	SHELF STANDARD (66)
67-70319	SHELF BRACKETS (8)
63-30273	WIRE SHELVES (4)
78-30568	STANDARD CLIPS (2)
55-80232	REAR MIRROR
51-80233	TOP GLASS
51-80234	END GLASS
53-80153	SELF-CLOSING DOOR (NORFAB)
05-80262	TOP DOOR TRACK
05-80263	BOTTOM DOOR TRACK
56-80269	DOOR GLIDES (8)
66-10716	FINGER PULLS (2)
81-10409	MIRROR HOLDERS
16-80249	GASKET (1/16 X 3/8)
16-80424	GASKET (1/8 X 5/16)
90-10734	SHELF BOX