



WILBUR CURTIS COMPANY, INC.

TXSG – Service Manual

Models Included:

● TXSG0101S600

● TXSG1501S600



WARNING – THERMOPRO SERVERS MAY BE HEAVY WHEN FILLED. CARE MUST BE TAKEN WHEN TRANSPORTING TO AVOID DROPPING OR SPILLING.

Use only coffee or water in the insulated dispenser. Do not use the ThermoPro server to dispense any other beverage. Preheating is recommended.

1. Place a clean and empty server centered under one of the brewcones of your coffee brewer.
2. Make sure the screen reads **READY TO BREW**.
3. Fill brewcone with the correct measure of ground coffee for the intended volume of brewed coffee.
4. Select the brew button that matches the brew volume and press to brew into the coffee dispenser.
5. Allow coffee in the brewcone to drip completely before removing the insulated dispenser.

SERVICING THE THERMOPRO SERVER

1. Completely drain the unit of any coffee.
2. Allow server to cool.
3. Unscrew and remove the lid and tube assembly.

REPLACING THE GAUGE GLASS

The gauge glass can be removed for maintenance and cleaning. Refer to the illustration on page three [3] for assembly sequence.

1. Unscrew the vented cap plug from the top of the gauge glass shield.
2. Carefully lift out the gauge glass tube from the shield and scrub inside the glass with a tube cleaning brush and mild detergent solution. Inspect the glass tube for cracks or chips. If broken, carefully remove all traces of glass and then insert a new gauge glass tube.
3. Check the top and bottom washers that make the tube water tight. Clean the washers. Make sure they are not leaking. Replace if necessary.
4. With the sight glass seated in the gauge glass shield, thread the cap plug onto the top of the shield. Do not overtighten.

REMOVING THE BASE & BOTTOM COVER

To replace the silicone elbow fitting for repair or cleaning:

1. Remove the base assembly. Press down on the slide tab on the back side of the stand and lift off the server section.
2. Turn the server upside down and take off the plastic bottom cover. This will reveal the silicone elbow fitting.
3. Remove the wire hose clamps by squeezing the wire ears together. While holding the clamp open, loosen the soft silicone elbow from the liner drain pipe and the faucet shank and pull out elbow.
4. Check for leaks and replace with a new part if necessary.
5. Reverse these steps to assemble.

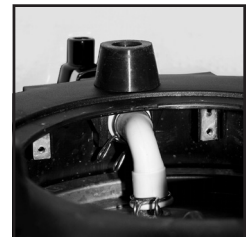

REMOVING THE FAUCET

The faucet will require periodic cleaning and maintenance.

1. Remove the faucet from the body of the server. Unscrew the large nut holding the faucet to the shank to take off faucet.
2. Disassemble the faucet. Unscrew the bonnet from the body of the faucet.
3. Remove the faucet handle by pressing inward on the seat cup (see photo at right) then unhooking the handle from the center shaft.
4. The seat cup, center shaft and spring will now separate from the bonnet. Clean these parts with a mild detergent solution.
5. While you have these parts for cleaning, check the seat cup for tearing or splitting. Make sure the faucet spring is free of corrosion. Replace with repair kit if necessary (item 13, page 3).



ASSEMBLY

Assemble the unit by reversing the steps for disassembly. Finger tighten only wing nut for faucet. Make sure clamps are fastened properly and silicone fittings are in good condition. Once assembled, check for leaks around the fitting and faucet.

Cleaning Instructions



CAUTION

- Do not immerse in water.
- Do not place in dishwasher.
- Do not use harsh powders or cleansers containing chlorine.

These cleaning and sanitizing instructions are only a guide line to be used for the cleaning and sanitizing of the TLXS dispenser. Your current in-house cleaning and sanitizing methods may be just as effective.

1. Daily – Rinse the unit between brews.

- a. Rinse unit with hot water and empty completely.
- b. Dry outside surfaces with a cleaning rag.
- b. To preheat, fill the insulated server with hot water and allow it to heat before emptying hot water. The empty server is now ready for brewing.

2. Cleaning the lid assembly.

- a. Unscrew the top lid from the insulated server and wash it in cleaning solution.
- b. Using the supplied brush, clean inside the filling tube.
- c. Rinse with clean water.

3. Cleaning and sanitizing body assembly.

- a. Partially fill the insulated server with cleaning solution. Use a sponge brush to thoroughly clean inside liner.
- b. Rinse the unit using a fresh water rinse.
- c. Pour sanitizing solution into the insulated server. Allow to sit for 5 minutes then drain through the faucet.
- d. Rinse by pouring water inside the unit, allowing rinse water to flow into a sink until water runs clear.
- e. Wipe outside of unit with clean cloth moistened with a mild cleaning solution.
- f. Place body assembly upside down on rack to thoroughly air dry.

4. Cleaning the faucet parts.

- a. Remove faucet (see Removing the Faucet on page 1) and gauge glass from unit and brush out with cleaning solution.
- b. Place in cleaning solution to soak for 5 minutes,
- c. With the faucet removed, use the tube brush soaked in cleaning solution to insert through the faucet shank.
- d. Rinse parts and dry.

5. Assemble parts that were removed.

Rough-In Drawing

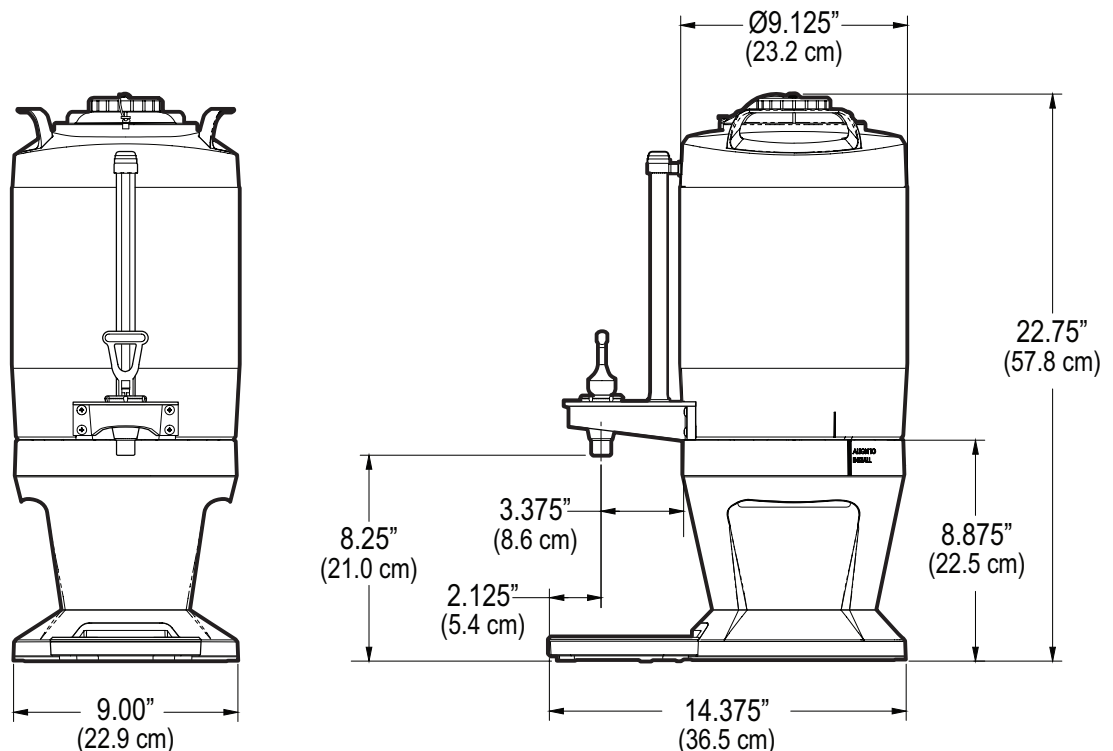

Illustrated Parts

ThermoPro Gravity Pot

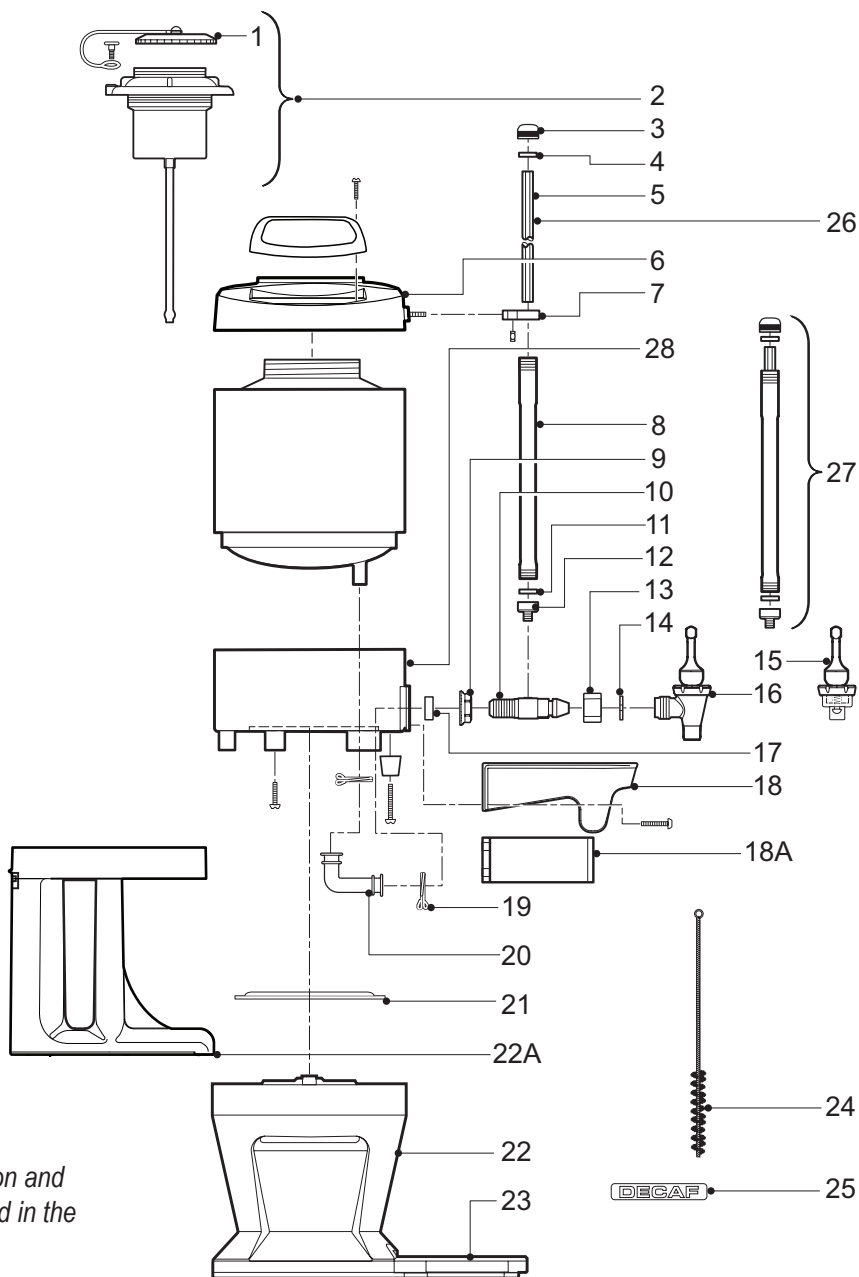

Illustrated Parts List

All parts are common between the 1 gallon and 1½ gallon servers, except where indicated in the description (**Bold type**).

Index N°	Part N°	Description	Index N°	Part N°	Description
1	WC-37387	KIT, CAP, TETHER & SCREW TXSG	15	WC-3705	KIT, FAUCET REPAIR
2	WC-56025	LID ASSY, TLXSG15	16	WC-1841	FAUCET, ESP BLACK LOCKING
2A	WC-56024	LID ASSY, TLXGS01	17	WC-56026	WASHER, SLCN .45 ID X.79OD .14TH
3	WC-2001-101	SHIELD CAP, W/VENT 77-4 BLK CHR	18	WC-64079	GUARD, FAUCET TXSG ZINC
4	WC-2005	WASHER, SHIELD CAP 1/8"	18A	WC-64074	GUARD, FAUCET TXSG PLASTIC
5	WC-2027	GLASS, GAUGE 10" TLXSG15	19	WC-43091	CLAMP, WIRE HOSE
5A	WC-2025	GLASS, GAUGE 8" TLXSG10	20	WC-2456	ELBOW, SILICONE STRT SIDE SRV
6	WC-56028	TOP SERVER THREADED BLK	21	WC-58262	COVER, BOTTOM WHITE PLASTIC
7	WC-2063	BRACKET, GAGE GLASS RING	22	WC-56020	BASE ASSY SERVER STRT SIDE
8	WC-2012-101	SHIELD, GAGE GLASS 10" TLXSG15	22A	WC-56013	BASE ASSY, SERVER (OPTIONAL)
8A	WC-2010-101	SHIELD, GAGE GLASS 8" TLXSG10	23	WC-61689	DRIP, TRAY ASSEMBLY TLXS
9	WC-1939-101	NUT, FLANGED	24	WC-36076	BRUSH, GAGE GLASS
10	WC-1938	SHANK, PLASTIC	25	WC-38281	LABEL, DECAF
11	WC-2006-101	WASHER, .188 X .188	26	WC-37396	KIT, GLASS GAUGE 10" 3PK TXSG15
12	WC-2004-101	SHIELD BASE GAGE GLASS BLACK	27	WC-37395	KIT, GAUGE ASSY 10" BLK TXSG15
13	WC-1903	NUT, UNION SHANK	28	WC-56030	BOTTOM, PLASTIC BLACK SERVER
14	WC-1906	C' RING .917 x .760 x .090			

Product Warranty Information

The Wilbur Curtis Company certifies that its products are free from defects in material and workmanship under normal use. The following limited warranties and conditions apply:

3 Years, Parts and Labor, from Original Date of Purchase on digital control boards.

2 Years, Parts, from Original Date of Purchase on all other electrical components, fittings and tubing.

1 Year, Labor, from Original Date of Purchase on all electrical components, fittings and tubing.

Additionally, the Wilbur Curtis Company warrants its Grinding Burrs for Forty (40) months from date of purchase or 40,000 pounds of coffee, whichever comes first. Stainless Steel components are warranted for two (2) years from date of purchase against leaking or pitting and replacement parts are warranted for ninety (90) days from date of purchase or for the remainder of the limited warranty period of the equipment in which the component is installed.

All in-warranty service calls must have prior authorization. For Authorization, call the Technical Support Department at 1-800-995-0417. Effective date of this policy is April 1, 2003.

Additional conditions may apply. Go to www.wilburcurtis.com to view the full product warranty information.

CONDITIONS & EXCEPTIONS

The warranty covers original equipment at time of purchase only. The Wilbur Curtis Company, Inc., assumes no responsibility for substitute replacement parts installed on Curtis equipment that have not been purchased from the Wilbur Curtis Company, Inc. The Wilbur Curtis Company will not accept any responsibility if the following conditions are not met. The warranty does not cover and is void under the following circumstances:

- 1) Improper operation of equipment: The equipment must be used for its designed and intended purpose and function.
- 2) Improper installation of equipment: This equipment must be installed by a professional technician and must comply with all local electrical, mechanical and plumbing codes.
- 3) Improper voltage: Equipment must be installed at the voltage stated on the serial plate supplied with this equipment.
- 4) Improper water supply: This includes, but is not limited to, excessive or low water pressure, and inadequate or fluctuating water flow rate.
- 5) Adjustments and cleaning: The resetting of safety thermostats and circuit breakers, programming and temperature adjustments are the responsibility of the equipment owner. The owner is responsible for proper cleaning and regular maintenance of this equipment.
- 6) Damaged in transit: Equipment damaged in transit is the responsibility of the freight company and a claim should be made with the carrier.
- 7) Abuse or neglect (including failure to periodically clean or remove lime accumulations): Manufacturer is not responsible for variation in equipment operation due to excessive lime or local water conditions. The equipment must be maintained according to the manufacturer's recommendations.
- 8) Replacement of items subject to normal use and wear: This shall include, but is not limited to, light bulbs, shear disks, "O" rings, gaskets, silicone tube, canister assemblies, whipper chambers and plates, mixing bowls, agitation assemblies and whipper propellers.
- 9) Repairs and/or Replacements are subject to our decision that the workmanship or parts were faulty and the defects showed up under normal use. All labor shall be performed during regular working hours. Overtime charges are the responsibility of the owner. Charges incurred by delays, waiting time, or operating restrictions that hinder the service technician's ability to perform service is the responsibility of the owner of the equipment. This includes institutional and correctional facilities. The Wilbur Curtis Company will allow up to 100 miles, round trip, per in-warranty service call.

RETURN MERCHANDISE AUTHORIZATION: All claims under this warranty must be submitted to the Wilbur Curtis Company Technical Support Department prior to performing any repair work or return of this equipment to the factory. All returned equipment must be repackaged properly in the original carton. No units will be accepted if they are damaged in transit due to improper packaging. **NO UNITS OR PARTS WILL BE ACCEPTED WITHOUT A RETURN MERCHANDISE AUTHORIZATION (RMA). RMA NUMBER MUST BE MARKED ON THE CARTON OR SHIPPING LABEL.** All in-warranty service calls must be performed by an authorized service agent. Call the Wilbur Curtis Technical Support Department to find an agent near you.



WILBUR CURTIS CO., INC.

6913 Acco St., Montebello, CA 90640-5403 USA

Phone: 800/421-6150 ♦ Fax: 323-837-2410

♦ Technical Support Phone: 800/995-0417 (M-F 5:30A - 4:00P PST)

♦ E-Mail: techsupport@wilburcurtis.com

♦ Web Site: www.wilburcurtis.com

ECN 12581.9/7/10@13.3.revH

FOR THE LATEST SPECIFICATION INFORMATION GO TO
WWW.WILBURCURTIS.COM