

INCOMING POWER  
230Vac 1PH  
2W+G 50/60 Hz

POWER BLOCK  
57-65A/300-450V

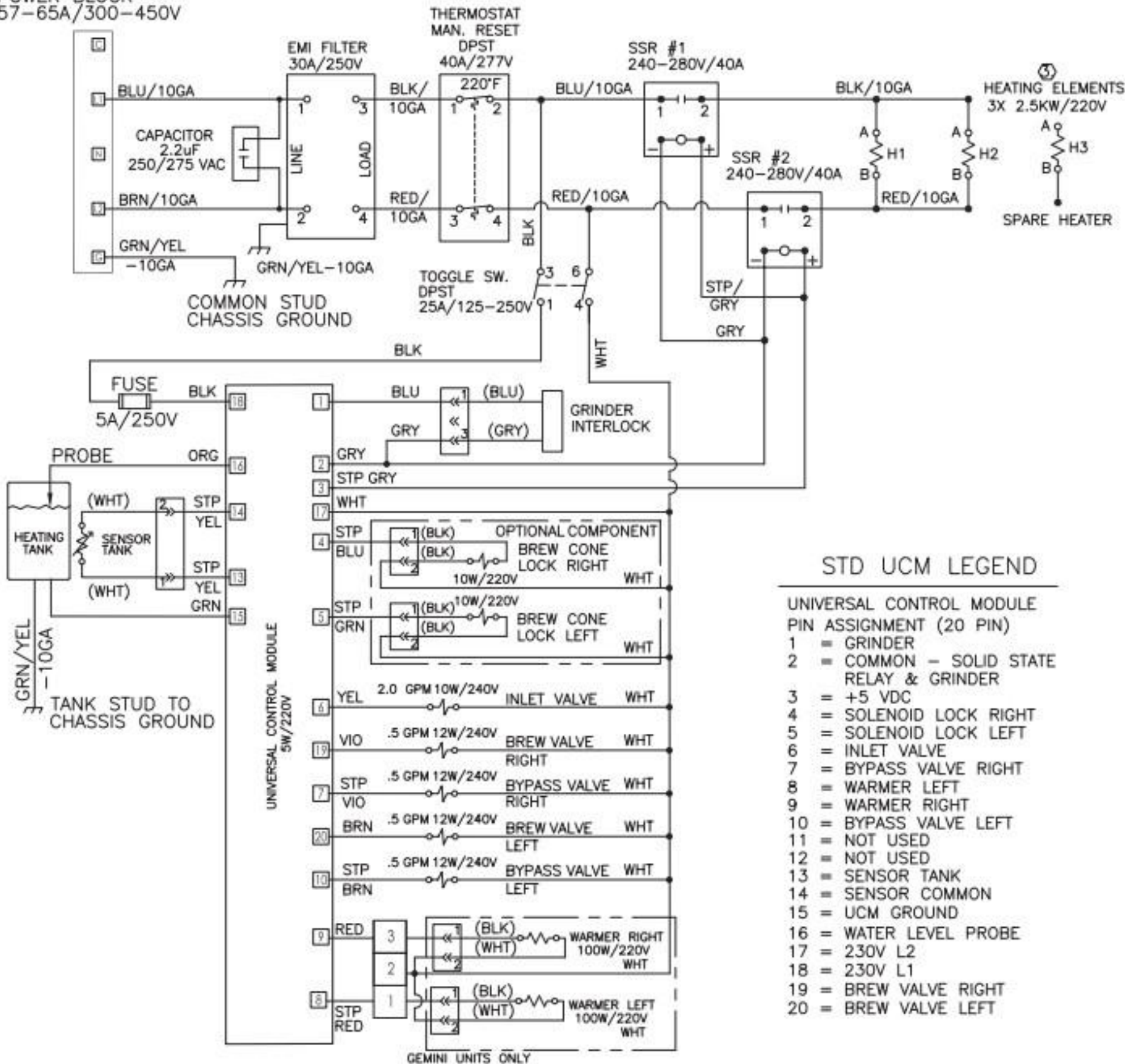

POWER BLOCK  
57-65A/300-450V

THERMOSTAT  
MAN. RESET  
DPST 40A/277V

SSR #1  
40A/600V

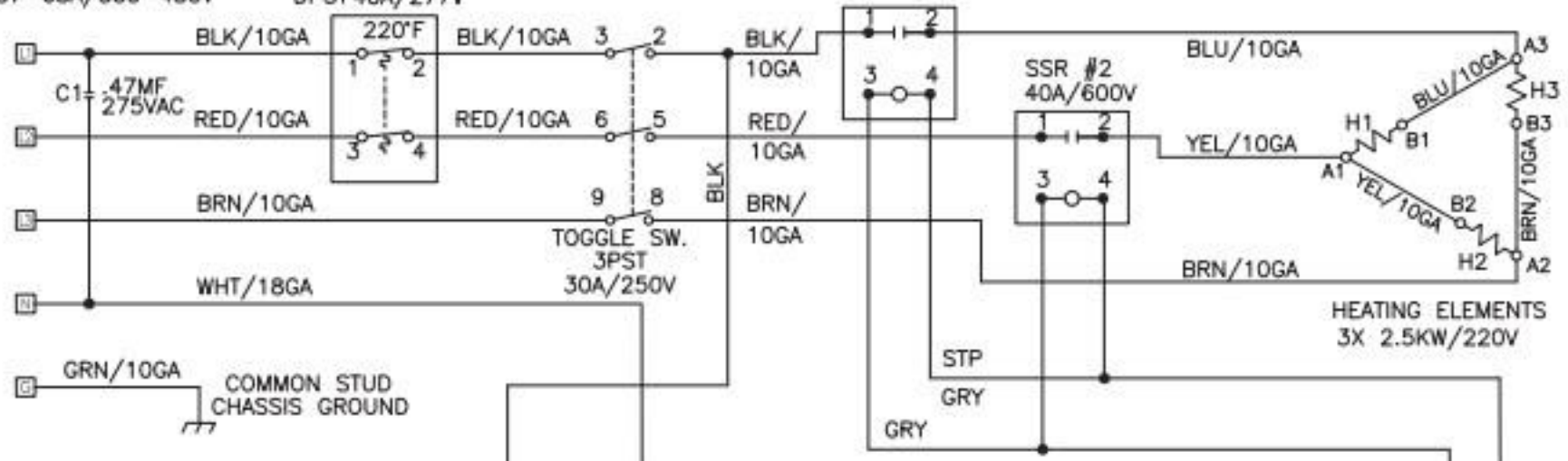

SSR PIN ASSIGNMENTS

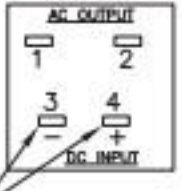

USE .187  
TERMINAL LUG

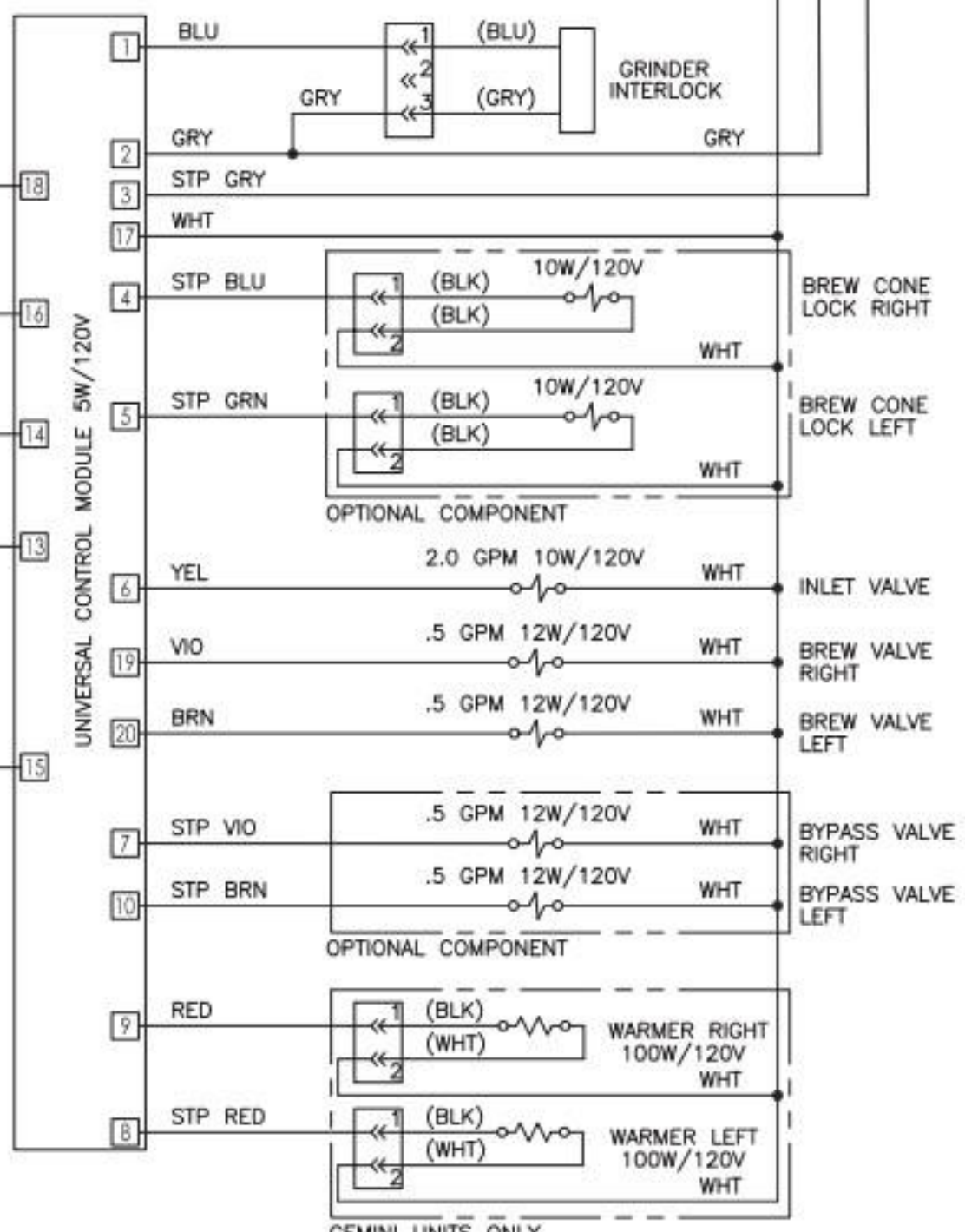
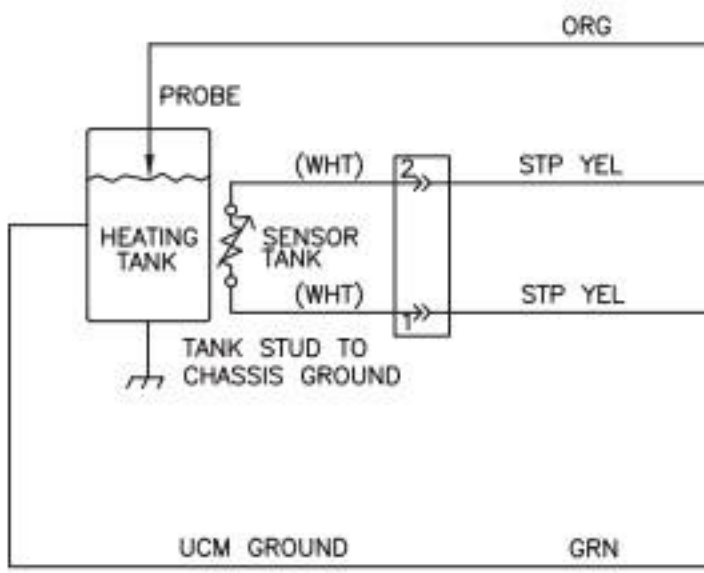
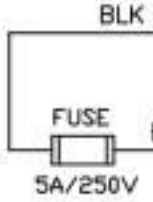

UNIVERSAL CONTROL MODULE  
PIN ASSIGNMENT (20 PIN)

- |  |                        |
|--|------------------------|
| 1 = GRINDER                              | 11 = NOT USED          |
| 2 = COMMON - SOLID STATE RELAY & GRINDER | 12 = NOT USED          |
| 3 = +5 VDC                               | 13 = SENSOR TANK       |
| 4 = SOLENOID LOCK RIGHT                  | 14 = SENSOR COMMON     |
| 5 = SOLENOID LOCK LEFT                   | 15 = UCM GROUND        |
| 6 = INLET VALVE                          | 16 = WATER LEVEL PROBE |
| 7 = BYPASS VALVE RIGHT                   | 17 = 120VAC RETURN     |
| 8 = BYPASS VALVE LEFT                    | 18 = 120VAC HOT        |

GEMINI UNITS ONLY



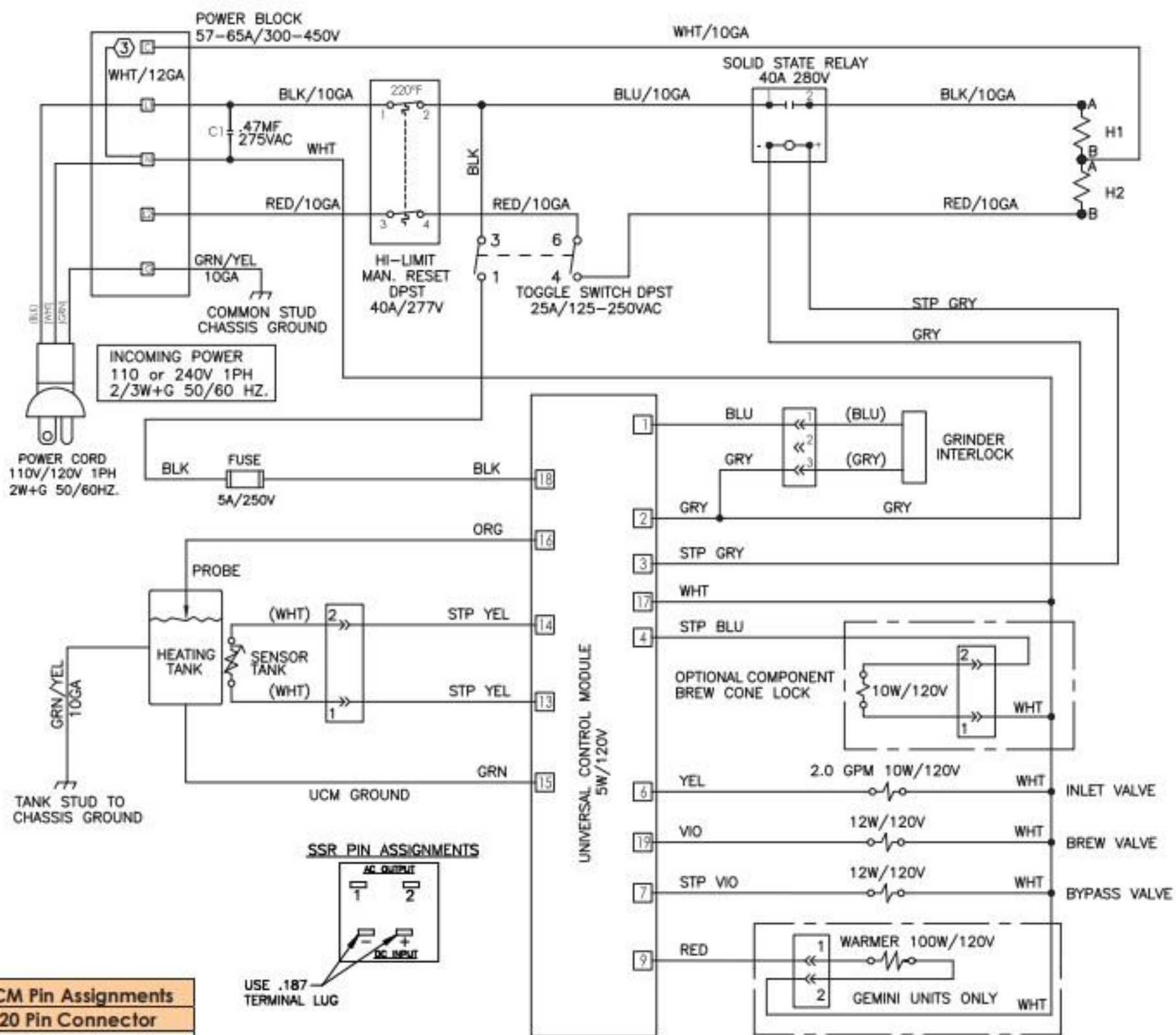

UCM Pin Assignments	
20 Pin Connector	
1	GRINDER INTERLOCK

INCOMING POWER  
220-240VAC 1PH  
2W+G 50/60 Hz

POWER BLOCK  
57-65A/300-450V

EMI FILTER  
30A/250V

HI-LIMIT MAN. RESET  
DPST 40A/277V

SOLID STATE RELAY  
40A/280V

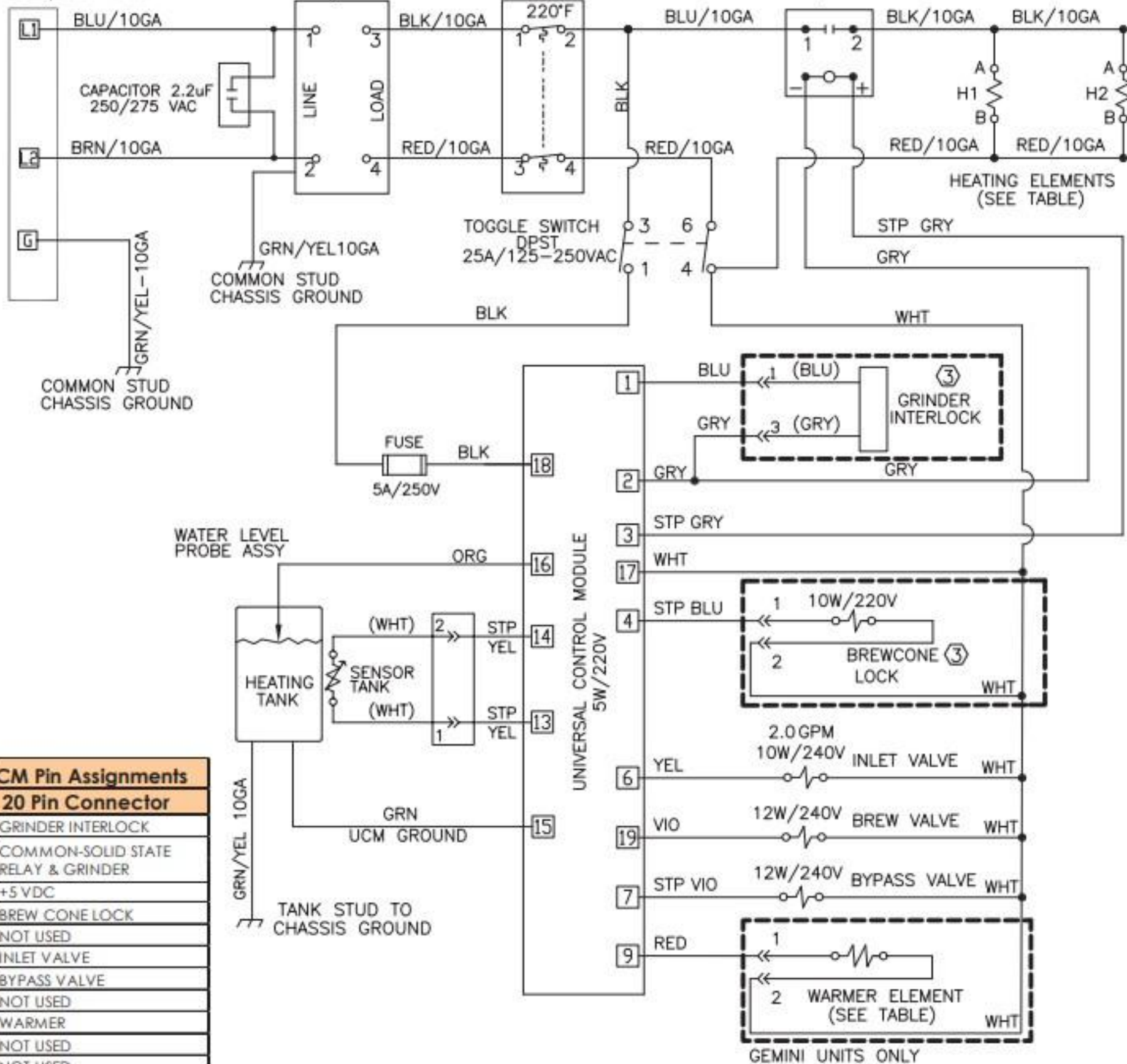

UCM Pin Assignments	
20 Pin Connector	
1	GRINDER INTERLOCK
2	COMMON-SOLID STATE RELAY & GRINDER
3	+5 VDC
4	BREW CONE LOCK
5	NOT USED
6	INLET VALVE
7	BYPASS VALVE
8	NOT USED
9	WARMER
10	NOT USED
11	NOT USED

GEMINI UNITS ONLY