



Service Manual – ThermoPro Twin & Single Brewers

Important Safeguards

This appliance is designed for commercial use. Any servicing other than cleaning and preventive maintenance should be performed by an authorized Wilbur Curtis service technician.

- DO NOT immerse the unit in water or any other liquid
- To reduce the risk of fire or electric shock, DO NOT open service panels. No user serviceable parts inside.
- Keep hands and other items away from hot surfaces of unit during operation.
- Never clean with scouring powders, bleach or harsh chemicals.

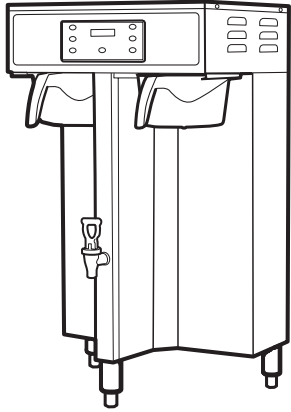

Models Included

- TP2T – ThermoPro Twin
- TP2S – ThermoPro Single

Symbols



WARNINGS – To help avoid personal injury



Important Notes/Cautions – from the factory



Sanitation Requirements

This Curtis Generation 3 Unit is Factory Pre-Set and Ready to Go... Right from the Carton.

Following are the Factory Settings for your G3 Coffee Brewing Systems:

- Brew Temperature = 200°F
- Water Bypass = On for LARGE & MEDIUM Brew Only
- Brew Volume = Set to Vessel Requirement.
- Sleep Mode = Off

System Requirements:

- Water Source 20 – 90 PSI (Minimum Flow Rate of 1 GPM)
- Electrical: See attached schematic for standard model or visit www.wilburcurtis.com for your model.

Setup Steps

The unit should be located on a solid counter top and leveled (left to right and front to back). Connect a water line from the water filter to the brewer.

NOTE: A water filtration system must be installed to maintain a trouble-free operation. (In areas with extremely hard water, we suggest that a sedimentary and taste & odor filter be installed.) This will prolong the life of your brewing system and enhance coffee quality.



NSF International requires the following water connection:

1. A quick disconnect or additional coiled tubing (at least 2x the depth of the unit) so that the machine can be moved for cleaning underneath the unit.
2. This equipment is to be installed with adequate back flow protection to comply with applicable federal, state and local codes.
3. Water pipe connections and fixtures directly connected to a potable water supply shall be sized, installed and maintained in accordance with federal, state, and local codes.

1. A 3/8" Flare x 3/8" Male pipe elbow is supplied with the brewer for water line connection. Use tubing sized sufficiently to provide a minimum of 1.0 GPM.
2. Connect the unit to an appropriate electrical power circuit.
3. Turn on the toggle (STANDBY/ON) switch behind the unit. The heating tank will start to fill. When the water level in the tank rises to the correct volume, the heating elements will energize automatically.
4. The heating tank will require 20 to 30 minutes to reach operating temperature (200°F), indicated when READY TO BREW is displayed on the LCD screen.
5. Prior to brewing, dispense 12 ounces of hot water through the hot water faucet.
6. Brew a cycle of at least 12 ounces, to purge the water lines of any air that may be trapped after filling.
7. Prior to brewing, dispense 12 ounces of hot water through the hot water faucet.
8. Brew a cycle of at least 12 ounces, to purge the water lines of any air that may be trapped after filling.
9. The ThermoPro brewer is now ready for operation.

WARNING HOT LIQUID,
Scalding may occur.
Avoid splashing.

CAUTION: Please use this setup procedure before attempting to use this brewer. Failure to follow the instructions can result in injury or the voiding of the warranty.

IMPORTANT: Equipment to be installed to comply with applicable federal, state, or local plumbing/electrical codes having jurisdiction.

CAUTION: DO NOT connect this brewer to hot water. The inlet valve is not rated for hot water.



ISO 9001 REGISTERED

WILBUR CURTIS COMPANY
Montebello, CA 90640

Your Curtis ADS System is Factory Pre-Set for Optimum Performance.

After connection to water and power; the rear toggle switch must be on. You will hear a beep sound, indicating power is available to the controller.

The control displays **WILBUR CURTIS**. Press ON/OFF button and the screen will display **THERMOPRO WILBUR CURTIS**. After three seconds, **WILBUR CURTIS FILLING...** is displayed.

Water will fill the tank (approximately 2-3 minutes depending on water flow rate). When the proper level is reached **WILBUR CURTIS HEATING...** will appear on the screen. It takes approximately 20 minutes to reach setpoint temperature of 200°F.

Control will display **WILBUR CURTIS READY TO BREW** when temperature reaches the setpoint (200°F); unit is at brewing temperature.

BREWING INSTRUCTIONS

1. Brewer should be ON (Confirm at rear toggle switch, then press the ON/OFF button). Screen should read Ready-to-Brew. If connected to an InterLock grinder. Grinder should be on.
2. Place an empty ThermoPro server centered beneath the brewcone.

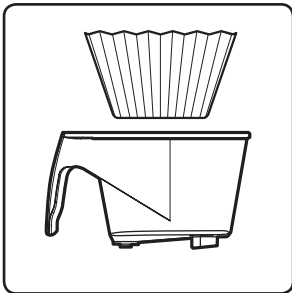

3. Place a clean filter into the brewcone.

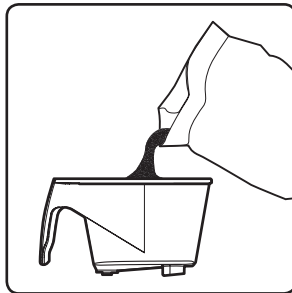

4. Fill brewcone with the proper amount of ground coffee. If Interlocked, fill the brewcone at the grinder.

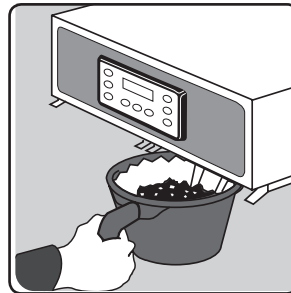

5. Transfer filled brewcone to the brew rails.

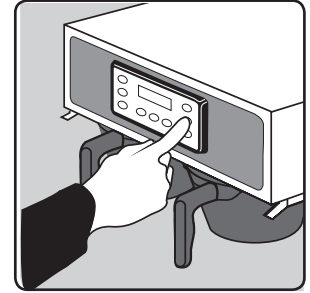

6. Select and press desired brew button. Brewing will begin immediately.



WARNING TO AVOID SCALDING, Do not remove brewcone while brew light is flashing.

ThermoPro Programming Guide

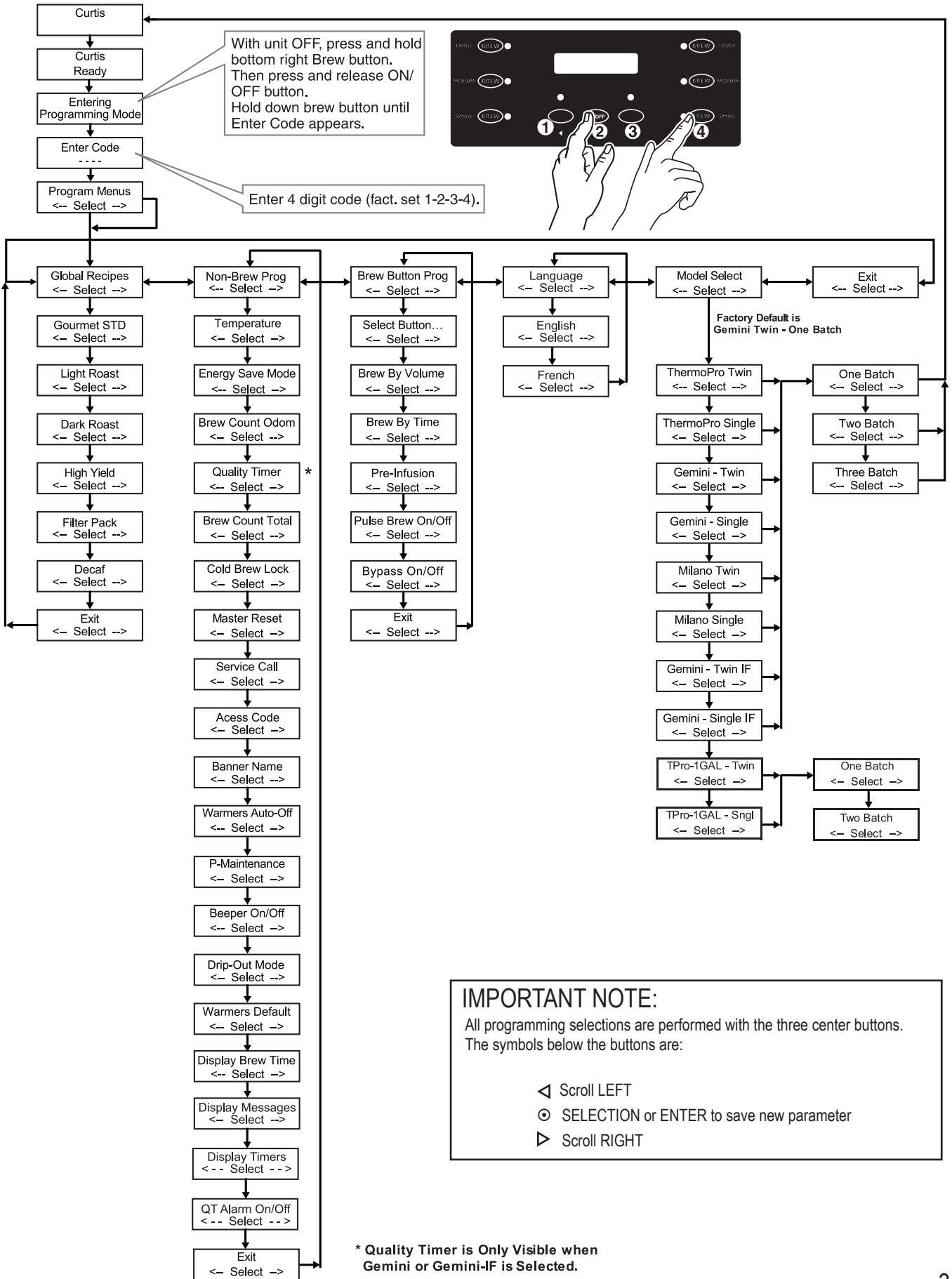

PARTS DIAGRAM

THERMOPRO
TWIN BREWER
TP2T

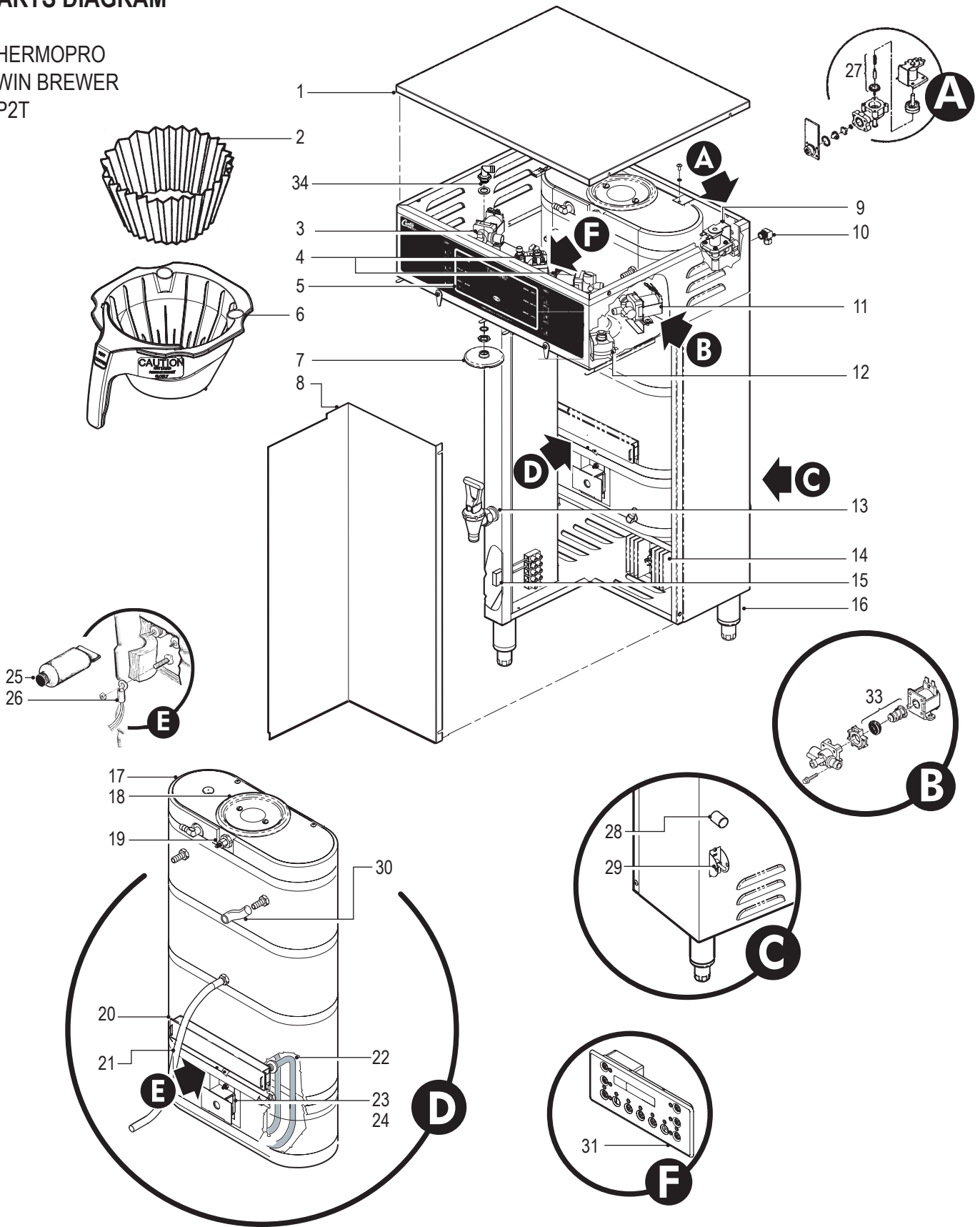

ILLUSTRATED PARTS LIST

THERMOPRO
TWIN BREWER
TP2T

ITEM №	PART №	DESCRIPTION
1	WC-5459	COVER, TOP WRAP
2	GEM-6	FILTER, 500/PKG (USE WITH WC-3417)
3	WC- 37121*	KIT, DUMP VALVE BREW LEFT
4	WC- 844-101*	VALVE, BY-PASS W/RESISTOR
5	WC-39442	LABEL, UCM OVERLAY TP2T TWIN 3-BATCH CURTIS
5A	WC-39415	LABEL, UCM OVERLAY TWIN 2-BATCH CURTIS
5B	WC-39414	LABEL, UCM OVERLAY TWIN 1-BATCH CURTIS
6	WC-3417	BREW CONE, ASSY W/SPLASH POCKET BROWN COF
7	WC-29050	SPRAYHEAD, ADVANCED FLOW
8	WC-58037-101	COVER, CENTER WRAP TP 90°
9	WC- 847*	VALVE, WATER INLET 2GPM 120V 10W
10	WC-2402P	ELBOW, 3/8"FL x 3/8" NPT PLATED
11	WC-37122*	KIT, DUMP VALVE BREW RIGHT
12	WC- 442	SOLENOID, LOCK BREW CONE RIGHT /LEFT 120V
12A	WC- 441	SOLENOID, LOCK BREWCONE LEFT (OLDER UNITS)
13	WC-1825	FAUCET, ASSEMBLY HOT WATER TP2S
14	WC-8559	RELAY, SOLID STATE W/INTEGRATED HTSNK
15	WC-8591*	CAPACITOR
16	WC-3528	LEG, 4" ADJUSTABLE 3/8-16 THRD ITALIAN STYLE
17	WC-62030	TANK, COMPLETE TP2T ULTEM FITTINGS
18	WC-37008	KIT, TANK LID ROUND
19	WC-5502-01*	KIT, PROBE, ASSY WATER LEVEL
20	WC-4382	GUARD, SHOCK HEATING ELEMENTS
21	WC-5310*	TUBE, 5/16" I.D. X 1/8" SILICONE
22	WC- 934-04*	ELEMENT, HEATING 2.5 KW 220V W/JAM NUTS
23	WC- 522*	THERMOSTAT, RESET
24	WC-43055	GUARD, SHOCK RESET THERMOSTAT
25	WC-5231*	COMPOUND, SILICONE
26	WC-1438-101*	SENSOR, HEATING TANK
27	WC-3765L*	KIT, VALVE REPAIR USE ON WC-825 & WC-826
28	WC-1501	FUSE HOLDER
29	WC- 102*	SWITCH, TOGGLE 125/250 VAC RESISTIVE
30	WC-5350*	TUBE, 1/2 ID x 1/8W SILICONE
31	WC-37176*	KIT, UCM & LABEL INSTRUCTIONS THERMOPRO
32	WC-13335	HARNESS ASSY, COMPLETE TP2T10 (NOT SHOWN)
33	WC-37132*	KIT, DUMP VALVE WC-820WC-821,WC-844
34	WC-2977-101K*	KIT,SPRAYHEAD FITTING PLASTIC

* RECOMMENDED PARTS TO STOCK.

PARTS DIAGRAM

THERMOPRO
SINGLE BREWER
TP2S

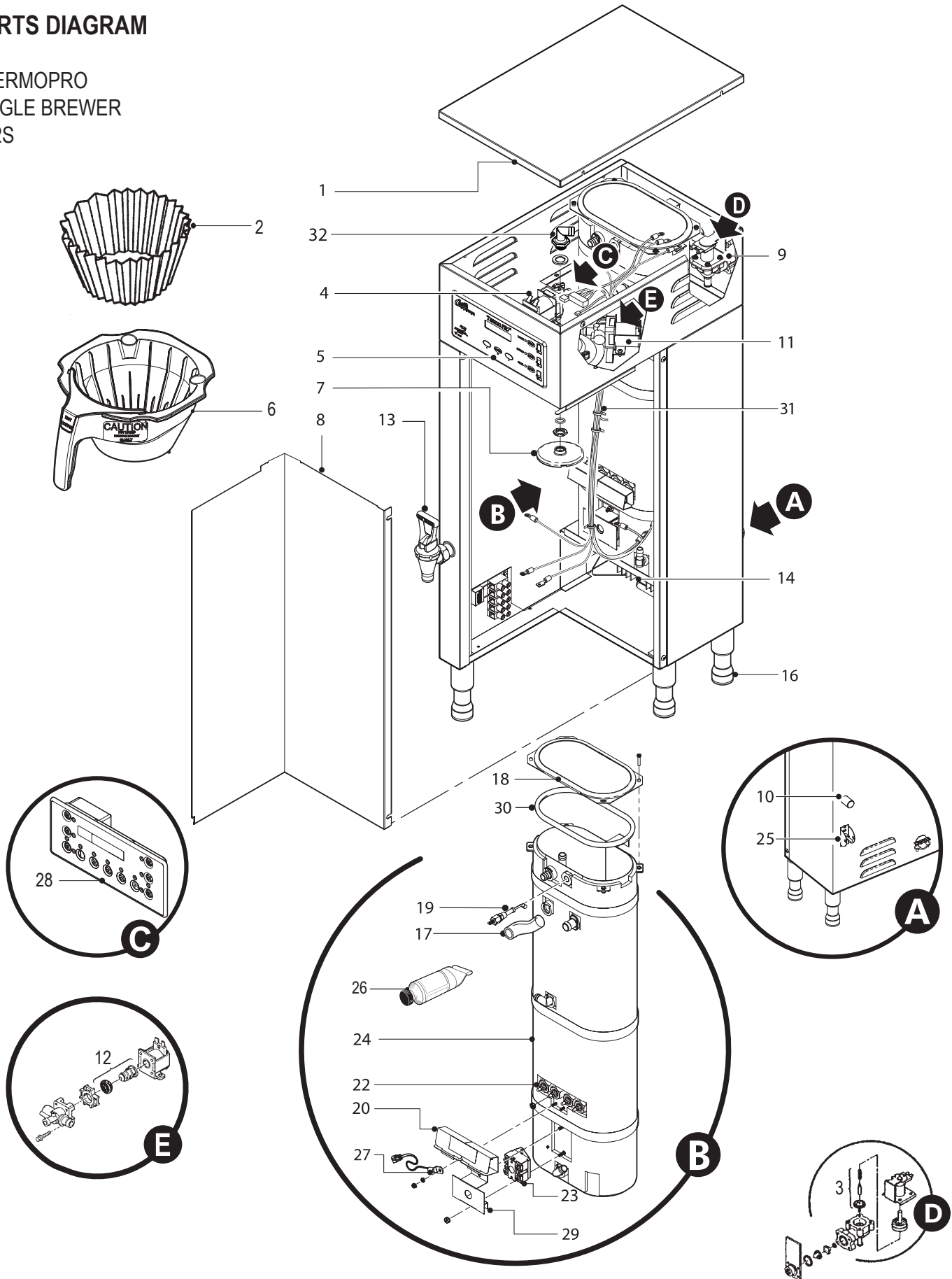

ILLUSTRATED PARTS LIST

THERMOPRO
SINGLE BREWER
TP2S

ITEM No	PART No	DESCRIPTION
1	WC-61509	COVER, TOP WRAP
2	GEM-6	FILTERS, 500/PKG (USE WITH WC-3417)
3	WC-3765L*	KIT, INLET VALVE REPAIR USE ON WC-826L/WC-847
4	WC- 844-101*	VALVE, ADJ BY-PASS
5	WC-39444	LABEL, UCM OVERLAY TP2S 3-BATCH CURTIS
5A	WC-39417	LABEL, UCM OVERLAY TP2S 1-BATCH CURTIS
5B	WC-39416	LABEL, UCM OVERLAY TP2S 2-BATCH CURTIS
6	WC-3417	BREW CONE, ASSY W/SPLASH POCKET BROWN COF
7	WC-29050*	SPRAYHEAD ASSY, ADVANCED FLOW
8	WC-58037-101	COVER, CENTER WRAP
9	WC- 847*	VALVE, WATER INLET 2GPM 120V 10W
10	WC-1501	FUSE HOLDER W/5A FUSE
11	WC-37122*	KIT, DUMP VALVE BREW RIGHT
12	WC-37132*	KIT, DUMP VALVE WC-820WC-821, WC-844
13	WC-1825	FAUCET ASSY, HOT WATER TP2S/2T
14	WC-8559*	RELAY, SOLID STATE 40A W/HEAT SINK
14A	WC-8556-101	HEATSINK, ASSY W/OPTICAL BD (OLDER UNITS)
15	WC-8591*	CAPACITOR, X2
16	WC-3528	LEG, 4" ADJUSTABLE 3/8-16 THREAD ITALIAN STYLE
17	WC-5350*	TUBE, 1/2 ID x 1/8W SILICONE
18	WC-5853-102	COVER, TOP HEATING TANK GEN USE
18A	WC-5851	COVER, TANK W/NOTCHES
19	WC-5502-01*	KIT, PROBE, ASSY WATER LEVEL
20	WC-4382	GUARD, SHOCK HEATING ELEMENTS
21	WC-5310*	TUBE, 5/16" I.D. X 1/8" SILICONE (NOT SHOWN)
22	WC- 904-04	ELEMENT, HEATING 1.6KW 120V W/JAM NUTS
22A	WC- 906-04*	ELEMENT, HEATING 2KW 220V W/JAM NUTS
23	WC- 522*	THERMOSTAT, RESET
24	WC-62031	TANK, COMPLETE TP2S DV ULTEM FITTINGS
24A	WC-62032	TANK, COMPLETE TP2S ULTEM FITTINGS
25	WC- 103*	SWITCH, TOGGLE NON-LIT DPST 25A 125/250VAC RST
26	WC-5231*	COMPOUND, SILICONE
27	WC-1438-101*	SENSOR, HEATING TANK
28	WC- 723*	CONTROL MODULE, 120V TP2S/TP2T
29	WC-43055	GUARD, SHOCK RESET THERMOSTAT
30	WC-43062*	GASKET, TANK LID
31	WC-13286	HARNESS ASSY, COMPLETE TP2S
32	WC-2977-101K*	KIT, SPRAYHEAD FITTING ULTEM

* RECOMMENDED PARTS TO STOCK.

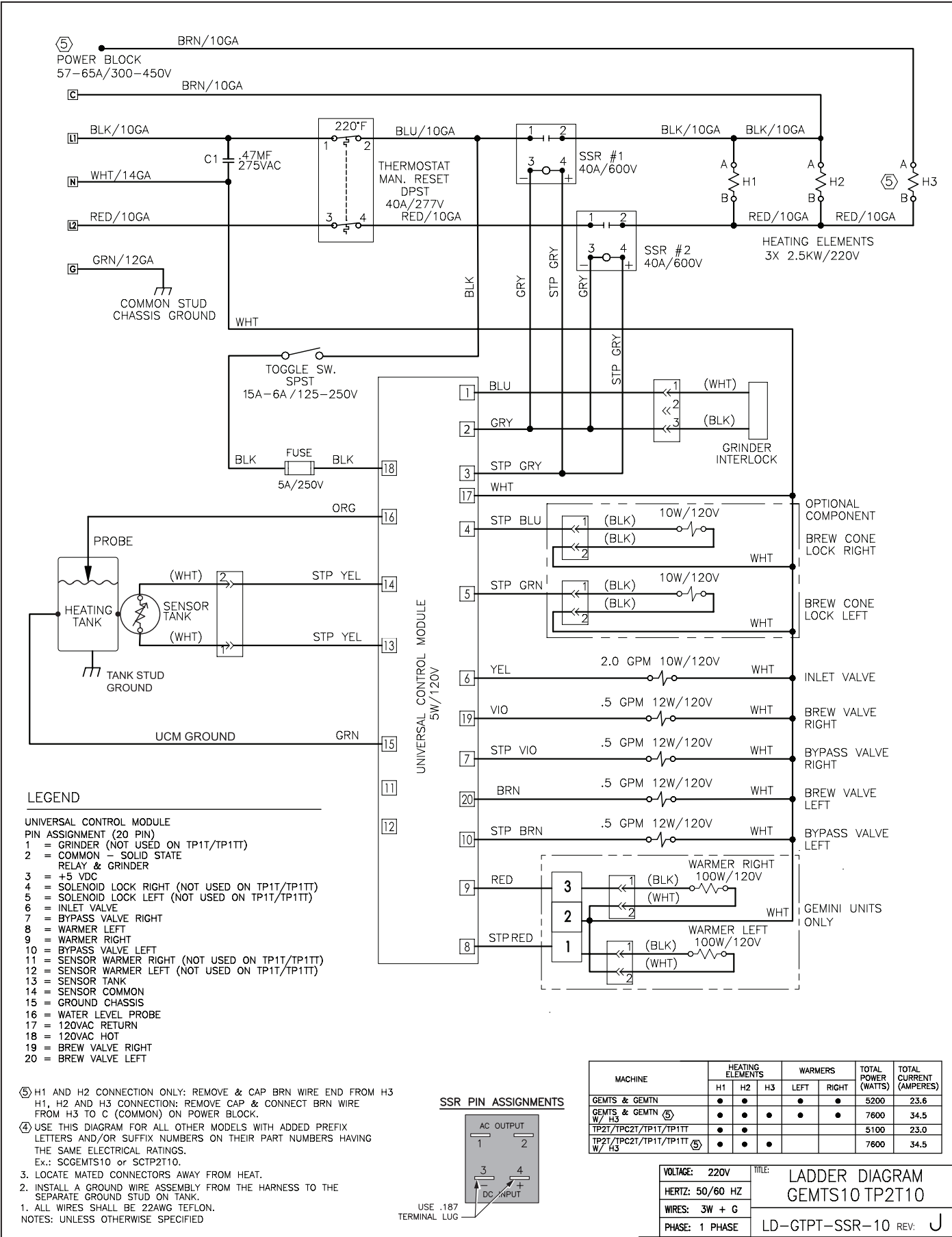

POWER BLOCK
57-65A/300-450V

SOLID STATE RELAY
40A/600V

HEATING ELEMENTS
2X 4.0KW 220VAC

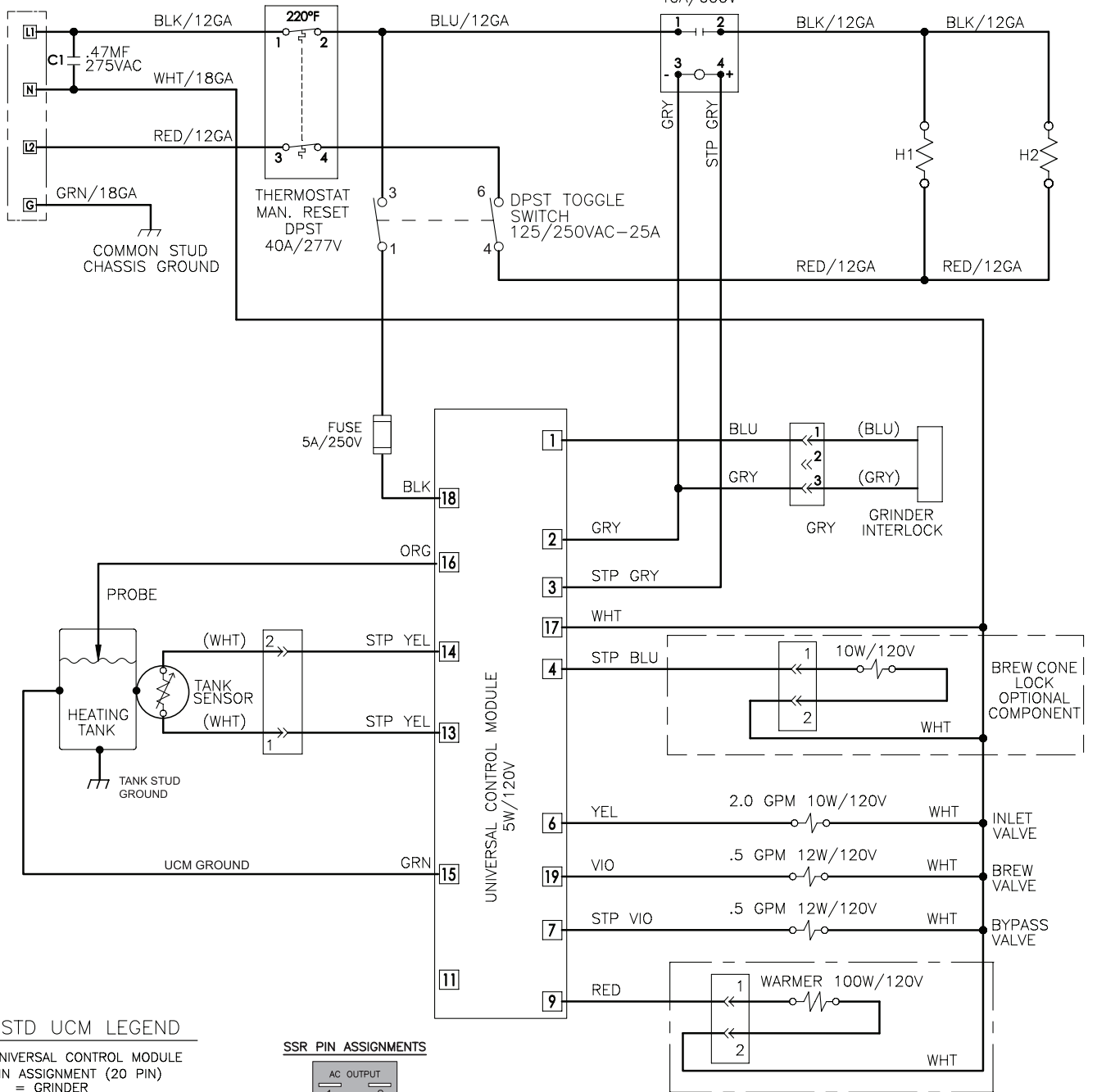

STD UCM LEGEND

- UNIVERSAL CONTROL MODULE
PIN ASSIGNMENT (20 PIN)
- 1 = GRINDER
 - 2 = COMMON - SOLID STATE RELAY & GRINDER
 - 3 = +5 VDC
 - 4 = SOLENOID LOCK RIGHT
 - 5 = SOLENOID LOCK LEFT
 - 6 = INLET VALVE
 - 7 = BYPASS VALVE RIGHT
 - 8 = WARMER LEFT
 - 9 = WARMER RIGHT
 - 10 = BYPASS VALVE LEFT
 - 11 = SENSOR WARMER LEFT
 - 12 = SENSOR WARMER RIGHT
 - 13 = SENSOR TANK
 - 14 = SENSOR COMMON
 - 15 = GROUND CHASSIS
 - 16 = WATER LEVEL PROBE
 - 17 = 120VAC RETURN
 - 18 = 120VAC HOT
 - 19 = BREW VALVE RIGHT
 - 20 = BREW VALVE LEFT

SSR PIN ASSIGNMENTS

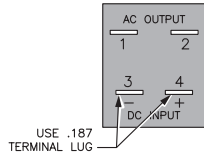

- ④ USE THIS DIAGRAM FOR ALL OTHER MODELS WITH ADDED PREFIX LETTERS AND/OR SUFFIX NUMBERS ON THEIR PART NUMBERS HAVING THE SAME ELECTRICAL RATINGS.
Ex.: SCGEMSS10 or SCTP2S10.
 3. LOCATE MATED CONNECTORS AWAY FROM HEAT.
 2. INSTALL A GROUND WIRE ASSEMBLY FROM THE HARNESS TO THE SEPARATE GROUND STUD ON TANK.
 1. NOTE REMOVED
- NOTES: UNLESS OTHERWISE SPECIFIED

ELECTRICAL RATING TABLE

MACHINE 220VAC	HEATING ELEMENTS		WARMERS	TOTAL POWER (WATTS)	TOTAL CURRENT (AMPERES)
	H2	H1			
TP2S/TPC2S	●	●		4300	19.5A
GEMSS	●	●	●	4300	19.5A

VOLTAGE: 220VAC	TITLE: LADDER DIAGRAM
WATTAGE: SEE TABLE	
AMPERAGE: SEE TABLE	
HERTZ: 50/60 HZ	
WIRES: 3W + G	PART NUMBER: LD-GTPS-SSR-10
PHASE: 1 PHASE	REVISION: C

Cleaning the ThermoPro

Regular cleaning and preventive maintenance is essential in keeping your coffee brewer looking and working like new. To clean the coffee brewer and components, prepare a mild solution of detergent and warm water.

CAUTION – Do not use cleansers, bleach liquids, powders or any other substance containing chlorine. These products promote corrosion and will pit the stainless steel. USE OF THESE PRODUCTS WILL VOID THE WARRANTY.

DAILY CLEANING

1. Wipe exterior surfaces with a damp cloth, removing spills and debris.
2. Slide the brewcone out and clean it. Wipe the sprayhead area with a cloth soaked in a mild detergent solution.
3. Rinse and dry the brewcone and sprayhead area.
4. Drain drip trays of coffee.
5. Dry the tray.

WEEKLY CLEANING

1. Turn off unit at the power switch, behind the unit. Allow the brewer to cool.
2. Clean the sprayhead and dome plate area.
 - a. Remove the sprayhead, unscrewing counterclockwise from the dome plate.
 - b. Thoroughly clean and rinse the dome plate area.
 - c. Clean the brewcone rails with a brush soaked with a mild detergent solution. Rinse the area with a cloth soaked with clean water, removing any residual detergent.
 - d. Dry the area.
- c. Attach the sprayhead.

Cleaning the Thermoserver

1. Drain coffee from the server.
2. Fill the liner with a mild detergent solution and let it stand for 10 to 15 minutes.
3. After about 15 minutes take a sponge brush and scrub out the stainless steel liner.
4. When clean, drain out the soapy solution from the server.
5. Fill the server with clean water to rinse detergent from inside the unit. Repeat this rinsing until the water runs clear.

CLEANING OF THERMOSEVER FAUCET

1. Remove the faucet handle assembly. Take hold of the bonnet and turn counterclockwise to unscrew it from the faucet.
2. Clean the handle assembly with a mild detergent solution. When clean, rinse the handle with water. Inspect for cracks or tears in the seat cup. Replace if damaged.
3. Clean the coffee level gauge glass.
 - a. Remove the sight glass cover by pulling up and off from the front of the server.
 - b. Using the narrow brush provided for this purpose, brush out the inside of the glass with a detergent solution. Rinse the sight glass tube of all detergent residue.
 - c. Pay special attention to the small gauge glass liquid level hole on the body of the faucet. You can brush this out with a small pipe cleaner.
 - d. Replace the sight glass. Make sure the top and bottom silicone seals are seated.

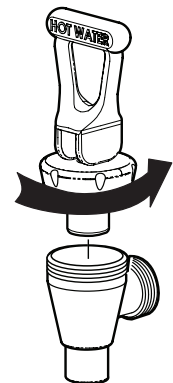

Page Intentionally Left Blank

Product Warranty Information

The Wilbur Curtis Company certifies that its products are free from defects in material and workmanship under normal use. The following limited warranties and conditions apply:

- 3 Years, Parts and Labor, from Original Date of Purchase on digital control boards.
- 2 Years, Parts, from Original Date of Purchase on all other electrical components, fittings and tubing.
- 1 Year, Labor, from Original Date of Purchase on all electrical components, fittings and tubing.

Additionally, the Wilbur Curtis Company warrants its Grinding Burrs for Forty (40) months from date of purchase or 40,000 pounds of coffee, whichever comes first. Stainless Steel components are warranted for two (2) years from date of purchase against leaking or pitting and replacement parts are warranted for ninety (90) days from date of purchase or for the remainder of the limited warranty period of the equipment in which the component is installed.

All in-warranty service calls must have prior authorization. For Authorization, call the Technical Support Department at 1-800-995-0417. Effective date of this policy is April 1, 2003.

Additional conditions may apply. Go to www.wilburcurtis.com to view the full product warranty information.

CONDITIONS & EXCEPTIONS

The warranty covers original equipment at time of purchase only. The Wilbur Curtis Company, Inc., assumes no responsibility for substitute replacement parts installed on Curtis equipment that have not been purchased from the Wilbur Curtis Company, Inc. The Wilbur Curtis Company will not accept any responsibility if the following conditions are not met. The warranty does not cover and is void under the following circumstances:

- 1) **Improper operation of equipment:** *The equipment must be used for its designed and intended purpose and function.*
- 2) **Improper installation of equipment:** *This equipment must be installed by a professional technician and must comply with all local electrical, mechanical and plumbing codes.*
- 3) **Improper voltage:** *Equipment must be installed at the voltage stated on the serial plate supplied with this equipment.*
- 4) **Improper water supply:** *This includes, but is not limited to, excessive or low water pressure, and inadequate or fluctuating water flow rate.*
- 5) **Adjustments and cleaning:** *The resetting of safety thermostats and circuit breakers, programming and temperature adjustments are the responsibility of the equipment owner. The owner is responsible for proper cleaning and regular maintenance of this equipment.*
- 6) **Damaged in transit:** *Equipment damaged in transit is the responsibility of the freight company and a claim should be made with the carrier.*
- 7) **Abuse or neglect (including failure to periodically clean or remove lime accumulations):** *Manufacturer is not responsible for variation in equipment operation due to excessive lime or local water conditions. The equipment must be maintained according to the manufacturer's recommendations.*
- 8) **Replacement of items subject to normal use and wear:** *This shall include, but is not limited to, light bulbs, shear disks, "O" rings, gaskets, silicone tube, canister assemblies, whipper chambers and plates, mixing bowls, agitation assemblies and whipper propellers.*
- 9) **Repairs and/or Replacements** *are subject to our decision that the workmanship or parts were faulty and the defects showed up under normal use. All labor shall be performed during regular working hours. Overtime charges are the responsibility of the owner. Charges incurred by delays, waiting time, or operating restrictions that hinder the service technician's ability to perform service is the responsibility of the owner of the equipment. This includes institutional and correctional facilities. The Wilbur Curtis Company will allow up to 100 miles, round trip, per in-warranty service call.*

RETURN MERCHANDISE AUTHORIZATION: *All claims under this warranty must be submitted to the Wilbur Curtis Company Technical Support Department prior to performing any repair work or return of this equipment to the factory. All returned equipment must be repackaged properly in the original carton. No units will be accepted if they are damaged in transit due to improper packaging. **NO UNITS OR PARTS WILL BE ACCEPTED WITHOUT A RETURN MERCHANDISE AUTHORIZATION (RMA). RMA NUMBER MUST BE MARKED ON THE CARTON OR SHIPPING LABEL.** All in-warranty service calls must be performed by an authorized service agent. Call the Wilbur Curtis Technical Support Department to find an agent near you.*

11/11/13@14.3 . ecn 15461 . rev M



WILBUR CURTIS CO., INC.
6913 Acco St., Montebello, CA 90640-5403 USA
Phone: 800/421-6150 Fax: 323-837-2410
Technical Support Phone: 800/995-0417 (M-F 5:30A - 4:00P PST)
Web Site: www.wilburcurtis.com

E-mail: techsupport@wilburcurtis.com