

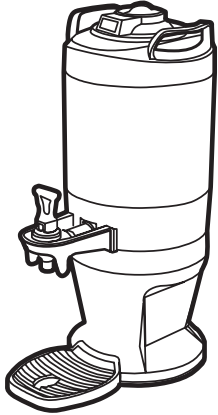

Service Manual – TFT FreshTrac™ Coffee Server



Models
TFT15G
TFT1G

Brewing into the TFT Server

The TFT server is designed to be used exclusively with coffee and water.

1. Place the clean, empty server centered under the brew cone of the coffee brewer. Remove the top cap from the FreshTrac™ lid
2. Fill brew cone with ground coffee. Insert it into the brew rails.
3. On the electronic controller of the brewer, press the brew button to start the brew cycle.
4. Allow the coffee brewer to complete the brew cycle. Make sure the brew cone has drained completely before removing the TFT server coffee server.



WARNING – Servers may be heavy when filled.
Care must be taken when transporting to avoid dropping or spilling.

FreshTrac™ Combination Liquid Level Gauge & Coffee Timer

The FreshTrac™ TFT coffee server uses a lid that has a combination gauge. This lid contains three indicators: A liquid level measure, a coffee quality timer, and LED lights.

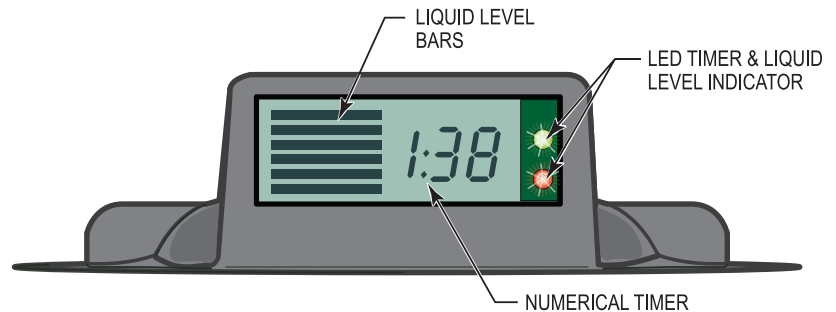

The FreshTrac™ activates as soon as brewed coffee starts flowing into the server.

At this time the two indicator lights flash green-red-green and the numeric timer starts counting down. Sensors within the lid measure the coffee as it fills the server. The segments of the liquid level gauge will start to fill in as the volume increases.

LED Lights

The two lights (Red & Green) are non-programmable.

1. Coffee is Fresh Mode — Green LED light blinks every 6 seconds to designate coffee is fresh. The Green LED is set to blink for 1 hour and 50 minutes.
2. Warning Mode – The Green and Red LEDs blink alternately – 6 seconds Green, 6 seconds Red, when either of these two conditions are true:
 - a. Digital Numeric Timer is 10 minutes or less from expiration.
 - b. Volume in server is between 12 and 24 ounces.
3. Timer Expired and/or Dispenser is (nearly) Empty – the Red LED blinks every 6 seconds for 60 minutes once any of the conditions below are true:
 - a. Numeric Timer has expired.
 - b. Dispenser is (nearly) empty – 12 ounces or less of volume remains.

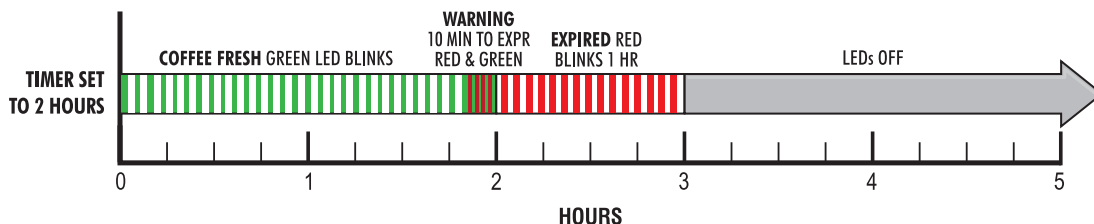

LED Lights

- The Red LED will stop blinking and turn off after 60 minutes have elapsed.
- When the server times-out or is empty, the LCD display screen will blink simultaneously with the LED.
- When the time has expired or the server is empty and the Red LED has blinked for 60 minutes, the LCD screen will turn off.

LCD – Liquid Level Bars

There are six bars on the LCD screen to represent the volume of coffee within the server. Table 1 and 2, below, will explain the volume range for each bar, as well as the response from the LED indicators as the volume decreases.

Table 1. Liquid Level Bars, 1.5 Gallon FreshTrac™

Number of Bars Visible	Approximate Range in Ounces	LED Response
Six (6) Bars	180 – 192	Green Light
Five (5) Bars	140 – 180	Green Light
Four (4) Bars	100 – 140	Green Light
Three (3) Bars	60 – 100	Green Light
Two (2) Bars	24 – 60	Green Light
One (1) Bar	12 – 24	Green/Red Light
Zero (0) Bars	0 – 12	Red Light

Table 2. Liquid Level Bars, 1.0 Gallon FreshTrac™

Number of Bars Visible	Approximate Range in Ounces	LED Response
Six (6) Bars	116 – 128	Green Light
Five (5) Bars	92 – 116	Green Light
Four (4) Bars	68 – 92	Green Light
Three (3) Bars	44 – 68	Green Light
Two (2) Bars	24 – 44	Green Light
One (1) Bar	12 – 24	Green/Red Light
Zero (0) Bars	0 – 12	Red Light

LCD – Numeric Timer

The FreshTrac™ digital numeric timer (Fresh Coffee Timer) defaults to 2 hours, counting down.

CLEANING TFT Coffee Server

- In a container, mix a mild detergent and warm water solution for cleaning the coffee server.
- Discard old coffee from the coffee server.
- Remove and clean the lid.
- Clean inside the coffee server with a sponge brush soaked in detergent solution.
- An easy way to remove mineral deposits from the brew cone and the coffee server is to use a pouch or tablet cleaner.
 - Place two tablets or one pouch (refer to manufacturers' recommendation) into the brew cone.
 - Place the empty coffee server onto the brew deck.
 - Start a coffee brew cycle by pressing the Brew button on the electronic controller.
 - When the brew cycle has finished, allow the cleaning solution to sit in the coffee server for a few minutes, then empty the coffee server.
- Wipe the exterior surfaces with a sponge moistened with the detergent solution. Wipe off coffee spots or stains.
- Rinse the brew cone and coffee server with running water.
- Dry the parts and return them to the coffee brewer.

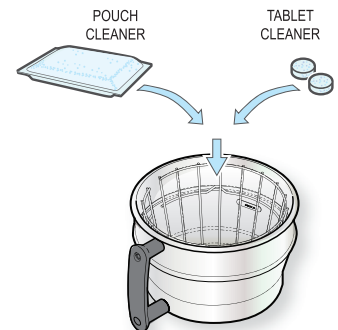
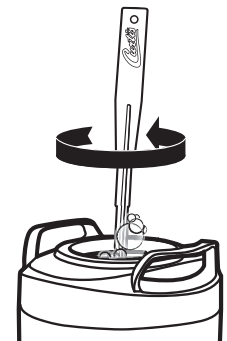

TFT Coffee Server Precautions:

- Do not immerse coffee server in water.
- Do not place in dishwasher.
- Do not use harsh powders or cleansers containing chlorine.
- Do not use a wire brush or pot scour to clean inside liner.

Illustrated Parts

TFT Coffee Server

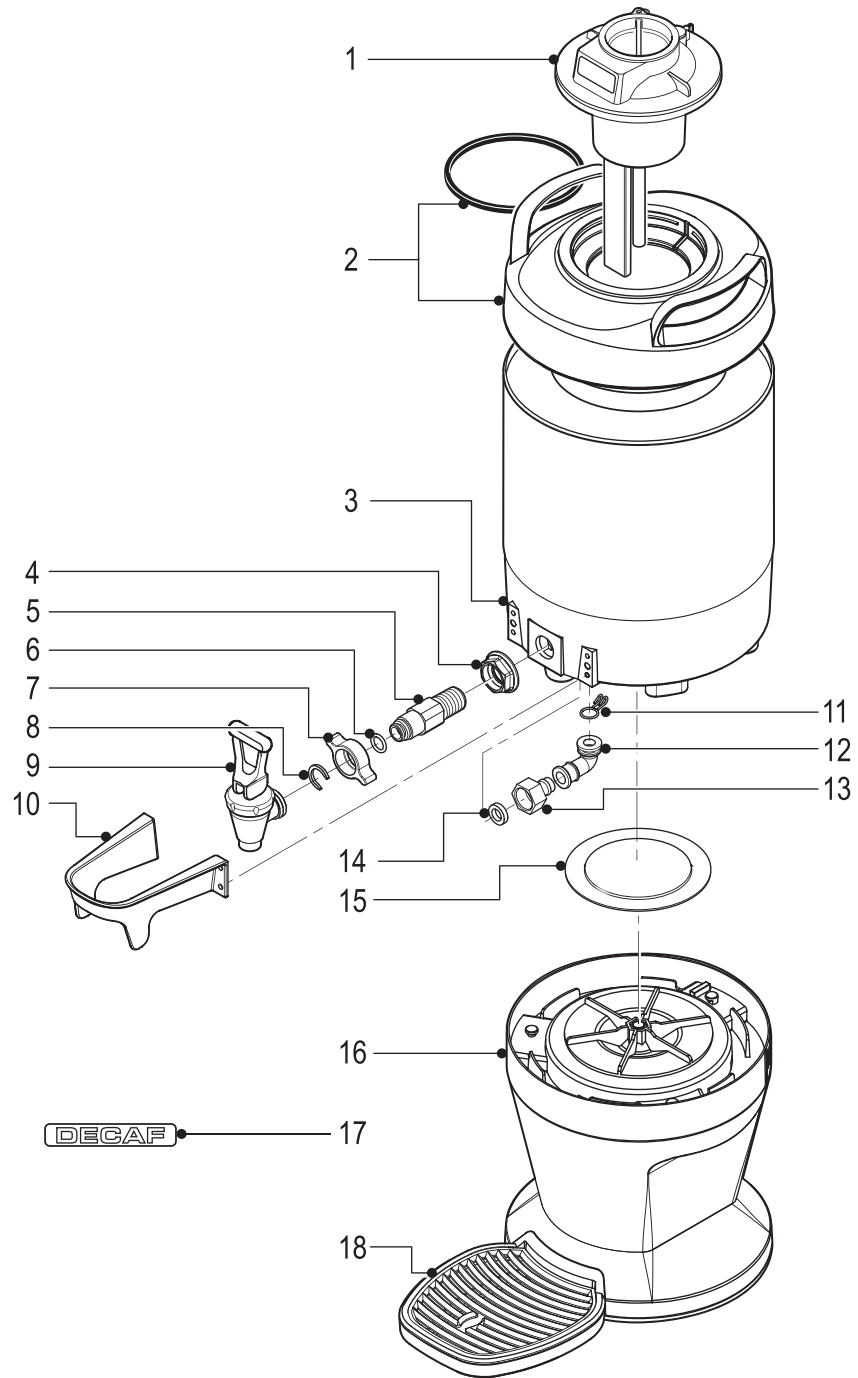

Illustrated Parts List

Index N°	Part N°	Description
1	WC-56076	LID ASSY, LCD/LED DISPLAY TFT15G
1A	WC-56075	LID ASSY, LCD/LED DISPLAY TFT1G
2	WC-56028-101	TOP SERVER THREADED BLK
3	WC-56030	BOTTOM, BLACK PLASTIC
4	WC-1951	NUT, FLANGED, PLASTIC
5	WC-1953	SHANK, PLASTIC
6	WC-4320	O'RING, 1/2" I.D.
7	WC-1905	NUT, WING PLASTIC 1-1/32-14UNF
8	WC-1906	C' RING .917 x .760 x .090
9	WC-1841	FAUCET, ESP BLACK LOCKING

Index N°	Part N°	Description
10	WC-64079	GUARD, FAUCET TXSG ZINC
11	WC-43091	CLAMP, WIRE HOSE
12	WC-2456	ELBOW, SILICONE STR SIDE SERV
13	WC-29082-101	FITTING, 1/2"-14 NPSM PLASTIC
14	WC-29082-102	WASHER, SILICONE .750OD x .453ID
15	WC-58262	COVER, BOTTOM WHITE PLASTIC
16	WC-56020	BASE ASSY SERVER STRT SIDE
17	WC-38281	LABEL, DECAF
18	WC-61689	KIT, DRIP TRAY STRAIGHT SIDE SRV

SERVICING THE TFT SERVER

REMOVING THE BASE & BOTTOM COVER

To replace the silicone elbow fitting for repair or cleaning:

1. Remove the base assembly. Press down on the slide tab on the back side of the stand and rotate the server counter clock-wise. Lift the server to separate from the base.
2. Turn the server upside down and pry off the plastic bottom cover. This will reveal the silicone elbow fitting.
3. Remove the wire hose clamps by squeezing in on the wire ears. Slide the clamp from the soft silicone elbow at the liner drain pipe and the faucet shank and pull off the elbow.
4. Check for leaks and replace with a new part if necessary.



REMOVING THE FAUCET

The faucet will require periodic cleaning and maintenance.

1. Remove the faucet from the body of the server. Take off the faucet by unscrewing the wing nut holding the faucet body to the shank.
2. Disassemble the faucet. Unscrew the bonnet from the body of the faucet. The handle and the faucet parts will come off in one piece.
3. Check the silicone seat cup for wear, cracks, or hardening. If okay, then leave the seat cup attached on the handle/bonnet assembly. Soak then wipe clean. Replace the faucet if damaged.

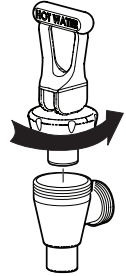

ASSEMBLY

Assemble the unit by reversing the steps for disassembly. Finger tighten the wing nut onto the faucet. Make sure all clamps are fastened properly and silicone fittings are in good condition. Before replacing the bottom cover, pour water into the server and check for leaks around the fitting and faucet. If okay, pour out the water and replace the cover and server base. The server is ready for coffee brewing.

TFT 1.5 Gallon

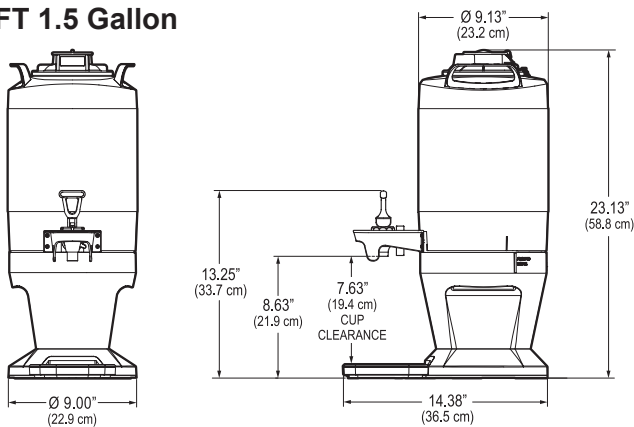

TFT 1.0 Gallon

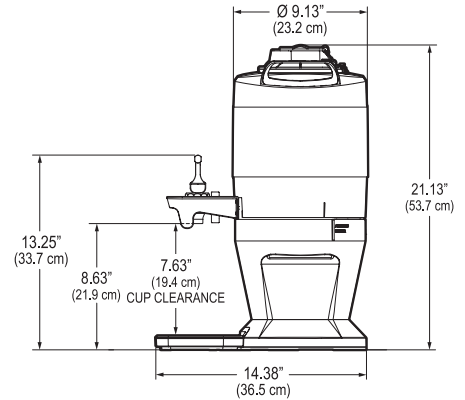

Product Warranty Information

The Wilbur Curtis Company certifies that its products are free from defects in material and workmanship under normal use. The following limited warranties and conditions apply:

1 Year from the Original Date of Purchase.

RETURN MERCHANDISE AUTHORIZATION: All claims under this warranty must be submitted to the Wilbur Curtis Company Technical Support Department prior to performing any repair work or return of this equipment to the factory. All returned equipment must be repackaged properly in the original carton. No units will be accepted if they are damaged in transit due to improper packaging. **NO UNITS OR PARTS WILL BE ACCEPTED WITHOUT A RETURN MERCHANDISE AUTHORIZATION (RMA). RMA NUMBER MUST BE MARKED ON THE CARTON OR SHIPPING LABEL.** All in-warranty service calls must be performed by an authorized service agent. Call the Wilbur Curtis Technical Support Department to find an agent near you.

ECN 15542 . 12/20/13 @ 9.1 . revC



WILBUR CURTIS CO., INC.

6913 Acco St., Montebello, CA 90640-5403 USA Phone: 800/421-6150 Fax: 323-837-2410

Technical Support Phone: 800/995-0417 (M-F 5:30A - 4:00P PST) E-Mail: techsupport@wilburcurtis.com

FOR THE LATEST SPECIFICATION INFORMATION GO TO
WWW.WILBURCURTIS.COM