





Models Included

- TCT with Sweet Tea Option

 **CAUTION:** Equipment must be installed to comply with applicable federal, state, and local plumbing/electrical codes having jurisdiction.

 **CAUTION:** Follow this setup procedure before attempting to use this unit. Failure to follow these instructions can result in injury and/or void of warranty.

 **CAUTION:** DO NOT connect the unit to hot water. The inlet valve is not rated for hot water.

 **IMPORTANT:** After setup, run a FULL brewcycle. Place a tea container to catch both hot water from the brewcone and dilution water from spout on the front cover.

ISO 9001:2008 REGISTERED

WILBUR CURTIS CO.
Montebello, CA 90640
For the latest information go to
www.wilburcurtis.com
Tel: 800/421-6150

Important Safeguards/Symbols

This appliance is designed for commercial use. Any servicing other than cleaning and routine maintenance should be performed by an authorized Wilbur Curtis Company service technician.

- DO NOT immerse the unit in water or any other liquid
- To reduce the risk of fire or electric shock, DO NOT open service panels. There are no user serviceable parts inside.
- Keep hands and other items away from hot areas of the unit during operation.
- Never clean with scouring powders or harsh chemicals.

Symbols:



WARNINGS – To help avoid personal injury



Important Notes/Cautions – from the factory



Sanitation Requirements

Your Curtis G3 Brewer is Factory Pre-Set and Ready to Go, Right Out of the Box. Following are the Factory Settings for your TCT Iced Tea Brewing System:

- Brew Temperature = 204°F
- Brew Volume = Set to dispensing vessel requirements

Generally there will never be a reason to change your G3 programming. However, should you need to make slight adjustments to meet your brewing needs, programming instructions are provided later in this manual.

System Requirements:

- Water Source 20 – 90 PSI (Minimum Flow Rate of 1 GPM)
- Electrical: See attached schematic for standard model or visit www.wilburcurtis.com for your model.

Equipment to be installed to comply with applicable federal, state, or local plumbing/electrical codes having jurisdiction.

SETUP STEPS

The unit should be level (left to right and front to back), located on a secure surface. Connect a water line from the water filter to the brewer.

NOTE: Some type of water filtration device must be used to maintain a trouble-free operation. (In areas with extremely hard water, we suggest that a sedimentary and taste & odor filter be installed.) This will prolong the life of your brewing system and enhance tea quality.



NSF International requires the following water connection:

1. A quick disconnect or additional coiled tubing (at least 2x the depth of the unit) so that the machine can be moved for cleaning underneath.
2. This equipment is to be installed with adequate backflow protection to comply with applicable federal, state and local codes..
3. Water pipe connections and fixtures directly connected to a potable water supply shall be sized, installed and maintained in accordance with federal, state, and local codes.

1. Plug in power cord.
2. Plumb water line. A 1/4" Flare has been supplied for water line connection. Use tubing sized sufficiently to provide a minimum of 1.0 GPM.
3. Connect the Bag-in-Box sweetener. Take the clear line with the QCD bag connector and hookup to the matching connector on the BIB sweetener (see Sweetener Connection, page 5). Insert the other end into the sweetener connector, behind the brewer..

SETUP STEPS (Continued)

4. Turn on the main power switch (bottom toggle switch, behind the brewer). The heating tank will start to fill. When the water level in the tank rises to the correct volume, the heating element will energize automatically. This eliminates the possibility of element burnout caused by an empty tank
5. Turn OFF the sweetener pump (top switch, behind the brewer).
6. The heating tank will require 20 to 30 minutes to reach operating temperature (204°F) indicated by READY-TO-BREW on the LCD readout.
7. Turn ON the sweetener pump at the toggle switch, behind the brewer. The pump will prime the sweetener product through the clear tubing.
8. Run one full brewcycle, to purge the water lines and valves of air. Five seconds of dilution water at the beginning of each brew-cycle is a normal function. This is a default of the system.
9. The unit is ready for the next brew.

BREWING INSTRUCTIONS

1. Brewer should be ON (Confirm at rear toggle switch, then press ON/OFF button) and Ready-to-Brew displayed.
2. Place filter in brew basket. Pour leaf tea into basket.
3. Slide brew cone into brew rails. Place tea container on brew deck.
4. Select a BREW button and press to start a brewcycle.

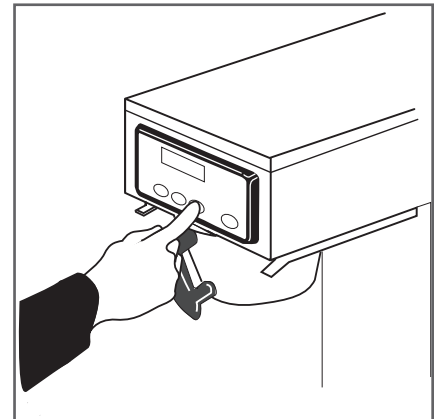
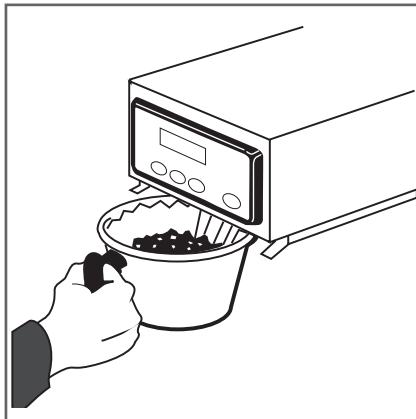

CAUTION HOT LIQUID, Scalding may occur. Avoid splashing.

Quick Start

TCT-SWEET TEA

Your Curtis ADS System is Factory Pre-Set for Optimum Performance.

After connection to water and power, the rear toggle switch must be on. You will hear a beep sound, indicating power is available to the controller.

The control displays **CURTIS**. Press ON/OFF button and the screen will display **<TCT G3> CURTIS**. After three seconds, **CURTIS FILLING** is displayed.

Water will fill the tank (approximately 2-3 minutes depending on water flow rate). When the proper level is reached **CURTIS HEATING** will appear on the screen. It takes approximately 20 minutes to reach setpoint temperature of 204°F.

Control will display **CURTIS READY TO BREW** when temperature reaches the setpoint (204°F). Unit is now ready to brew.

Programming

ENTER PROGRAMMING: Turn off at the ON/OFF button (yellow). Press and hold BREW button (green) and then press and release ON/OFF button (yellow).

Continue holding BREW button. Display will read ENTERING PROGRAM MODE, wait until ENTER CODE
.... is displayed Enter the 4-digit access code, the digits 1-4 correspond to the buttons (see illustration below). The default code set at the factory is 1-2-3-4. Then PROGRAM MENU
< SELECT > will be displayed.

 Current tea brewers are manufactured with **PURPLE** sprayheads. The UCM is comes programmed with Standard Tea Purple as the default. Older units with the GRAY sprayhead use the same programming method but with a slightly different menu sequence from the features listed below.

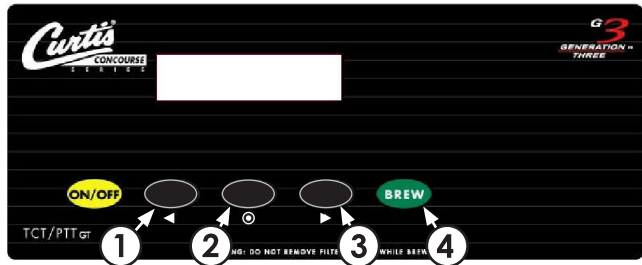
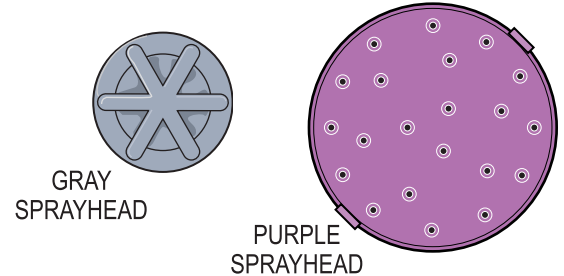

All programming selections are performed with the three center buttons. The symbols below the buttons are:

- ◀ Scroll LEFT
 - ⊙ SELECTION or ENTER to save new parameter
 - ▶ Scroll RIGHT
- Exit Press ⊙ to select, exits program mode and returns unit to operation.

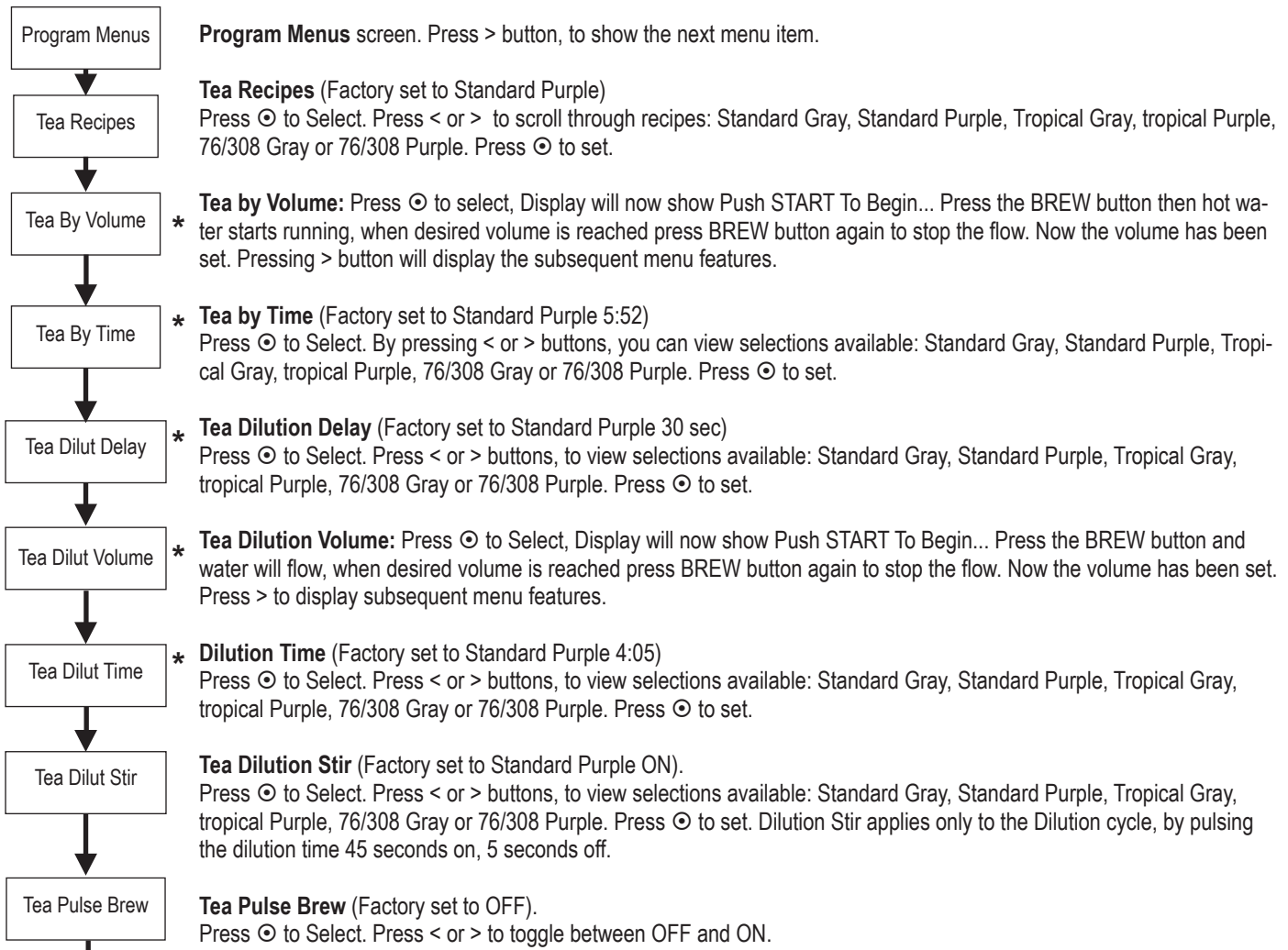

* On units with the **half batch option**, the half batch brew button may be independently set.

Continued on Page 4

PROGRAM MENUS CONTINUED

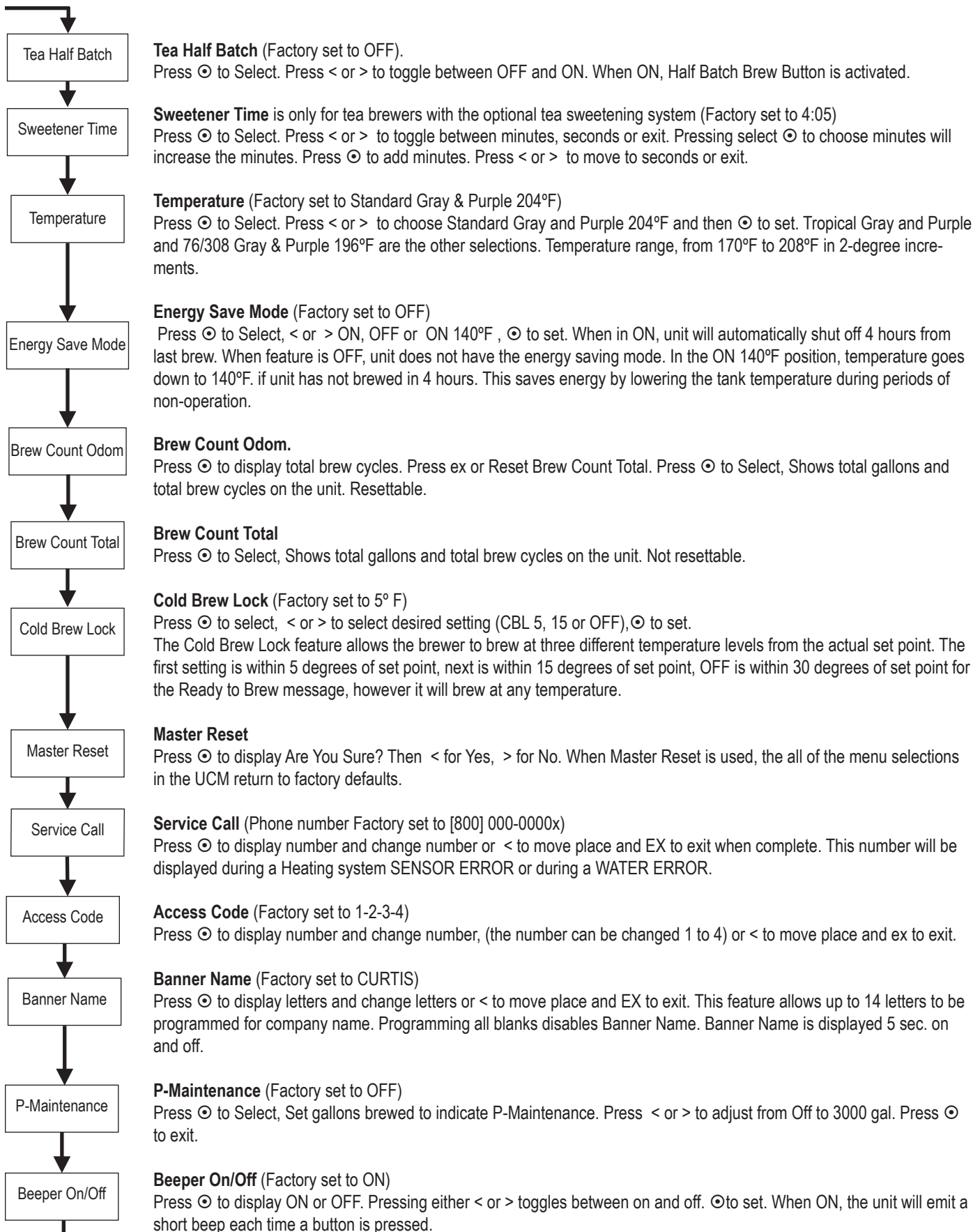

PROGRAM MENUS CONTINUED

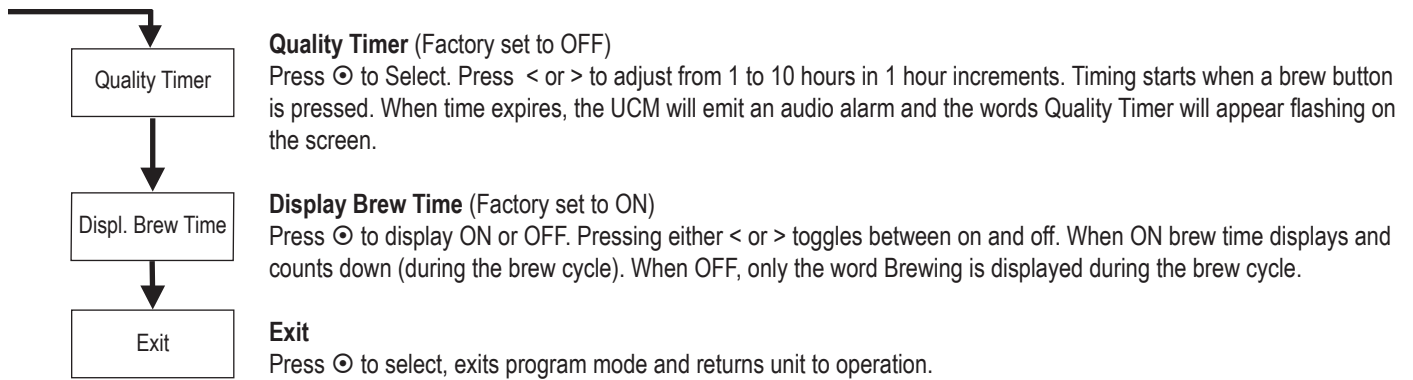

Tank Temperature Check

Turn on brewer at the control panel ON/OFF button. Press and hold $\textcircled{3}$ button (see illustration, page 2) for 5 seconds. Water Temperature will be displayed (temperature in heating tank).

SWEETENER CONNECTION PROCEDURE

Bag-In-Box



1. Pull off the shipping cap that covers the spout on the bag.

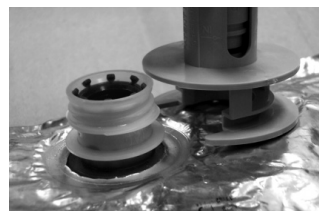

2. Place the QCD next to the spout.

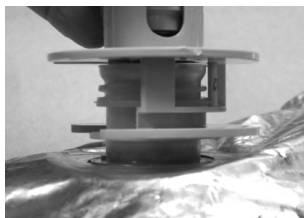

3. Slide QCD sideways, over the bag spout. QCD snaps in place.



4. Push QCD plunger into bag spout until plunger top is flush with top of QCD. A "click" will be heard when it is fully inserted.

5. Once the QCD is attached, place the BIB inside the dispenser in an inverted position, with the spout and connector pointed downward. This allows for more complete use of product while the bag empties. See Sweetener Schematic on page 7.



WARNING DO NOT refrigerate unused tea overnight for later consumption.

TEA TIPS

- Store tea bags in a dark, cool and dry place away from strong odors and moisture. Do not refrigerate.
- Do not hold brewed tea overnight.
- Make sure your equipment is clean at all times. Clean tea-brewing equipment at least once a day.
- Sanitize equipment at least once per week.
- Do not let fresh-brewed iced tea sit at room temperature for more than 8 hours.

As with other food products, if you adhere to proper preparation, holding and sanitation procedures, fresh-brewed iced tea is a safe beverage.

The primary cause for high bacteria counts found in tea from food service businesses is related to excessive holding times and/or poor cleaning and sanitizing procedures.

TEA BREWER CLEANING



IMPORTANT: Clean out the screen, within the brewcone, to maintain the flow of brewed tea. Neglecting this screen will eventually cause the brewcone to overflow, spilling hot liquid over the unit.



CAUTION: DO NOT use undiluted bleach or chlorine.



CAUTION: Never remove faucet when container is full. Drain container first.

SWEET TEA MIXING SYSTEM CLEANING & SANITIZING

DAILY

1. Wipe any spills, dust or debris from the exterior surfaces with a damp cloth. The outside surfaces of the brewer should be cleaned with stainless steel polish only, to prevent scratches.
2. Clean the sprayhead and domed area around the sprayhead with a mild detergent and warm water solution. Scrub well to remove residue. Rinse with and clear water. Dry with clean cloth.
3. Remove the plastic brewcone and wash with a detergent solution or put through a dishwasher.
4. Wash the tea container.
 - A. Clean container and top cover with a detergent solution.
 - B. Remove the faucet assembly. Unscrew the handle assembly from the faucet and remove. Clean the faucet shank with a gauge glass brush (circular bristle) by pushing the brush through the shank.
 - C. Unscrew the bonnet assembly from the faucet. Brush clean the faucet body inlet and outlet. Clean the faucet cap and silicone seat cup. Dry and assemble parts.

WEEKLY CLEANING & SANITIZING

The brewer is programmed for the sweetener to pour into the tea at the end of the brewcycle. Setting the brewer to Tea Fast Brew can speed up the cleaning procedure (see page 3 and 4 for programming instructions to turn on Tea Fast Brew).

Use a concentrated cleaning solution to simplify the cleaning procedure. This procedure requires a one gallon bucket of a cleaning solution of hot water (minimum 160°F) and a granulated cleaner (a cleaner like Coffee Dispenser Cleaner Corporation JavaClean3), diluted at 1.5 oz per gallon and a one gallon bucket of clean hot water (minimum 165°F).

1. Make sure brewer is on and water supply is hooked up.
2. Remove the quick disconnect from the tea sweetener bag-in-box product.
3. Pull the cap off of the QCD and place this end of the line into the container containing the cleaning solution (see illustration below).

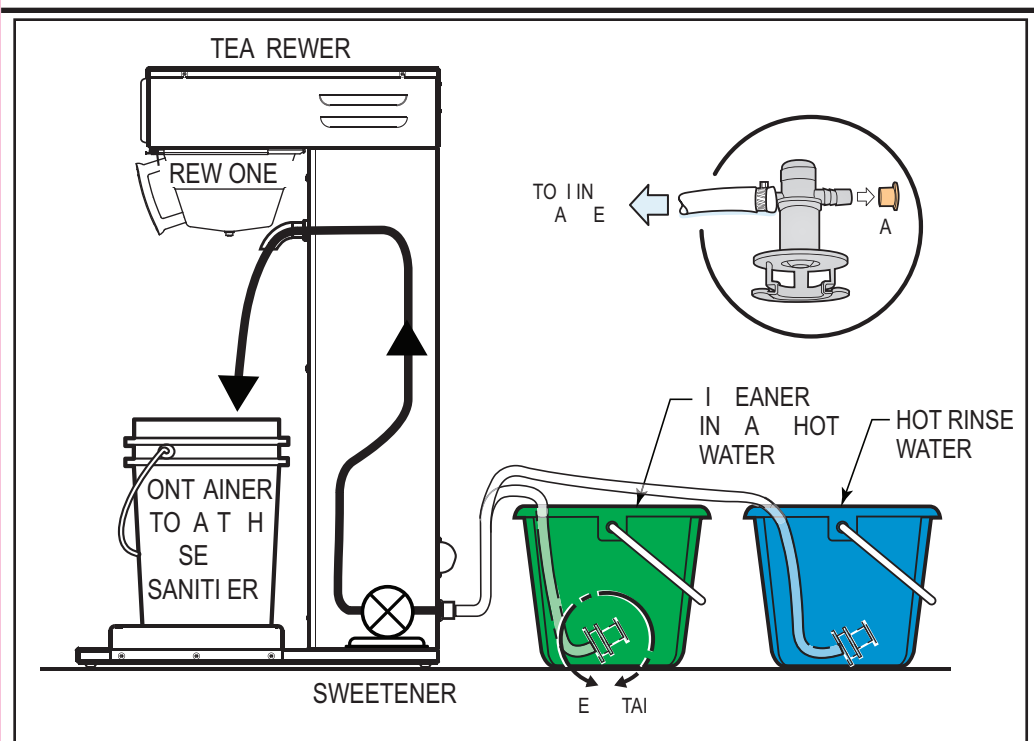

4. Place an empty tea container on the brew deck and an empty brewcone into the rails below the sprayhead.
5. Press the SWEET TEA brew button to run one complete brewcycle.
6. Allow the brewer to sit overnight with the cleaning solution in the sweetener line before flushing cleaning solution.
7. Flush the system by filling a one gallon container with clean hot water (no cleaning solution) and press the SWEET TEA brew button to run a brewcycle until all the cleaning solution has been flushed from the system.
8. Discard solution that poured into the container.
9. Remove the QCD from the flushing container and replace the cap. Reconnect the QCD to the Bag in the Box sweetener.
10. If desired, reset Tea Fast Brew to OFF. The unit is ready to resume brewing.

SWEETENER SCHEMATIC LAYOUT

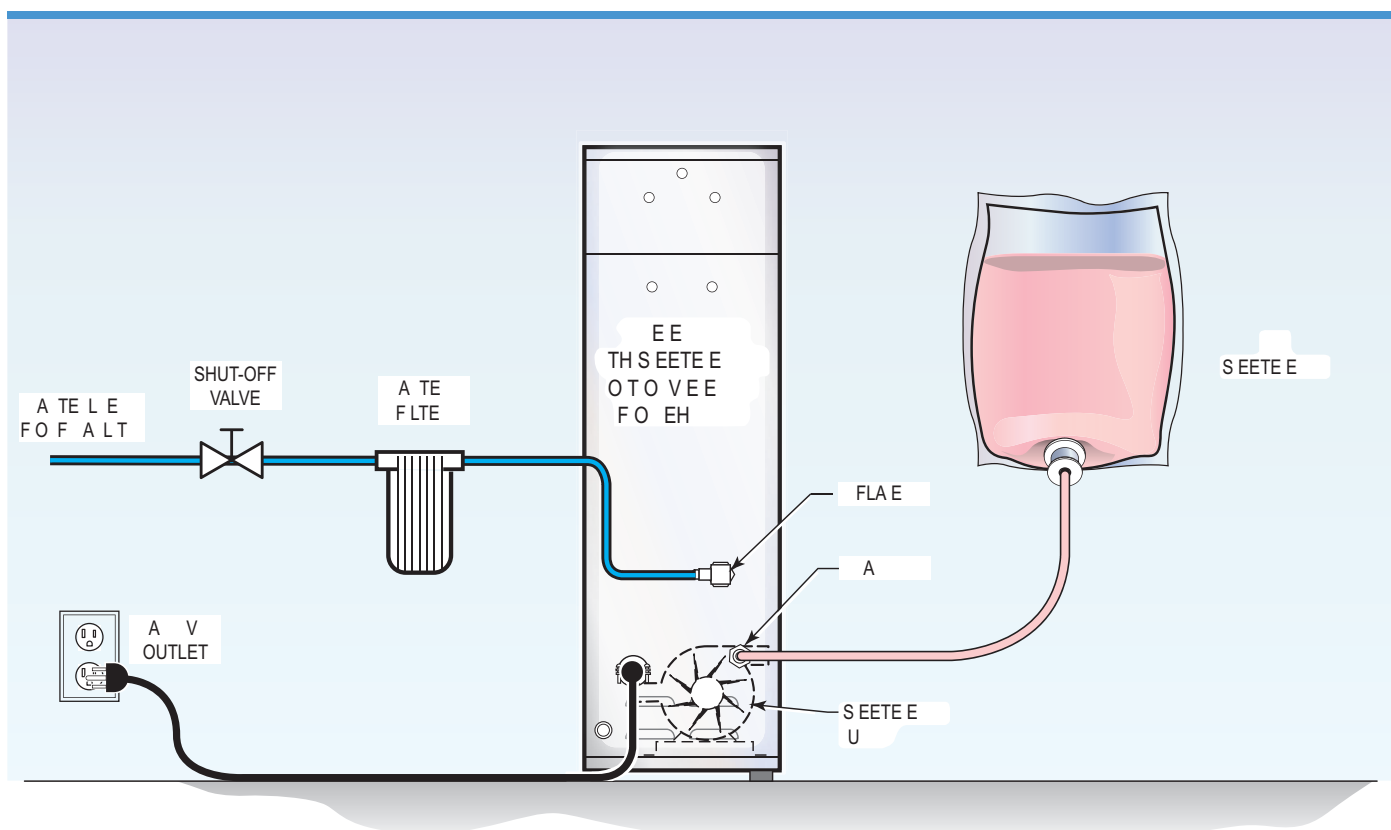

ILLUSTRATED
PARTS LIST

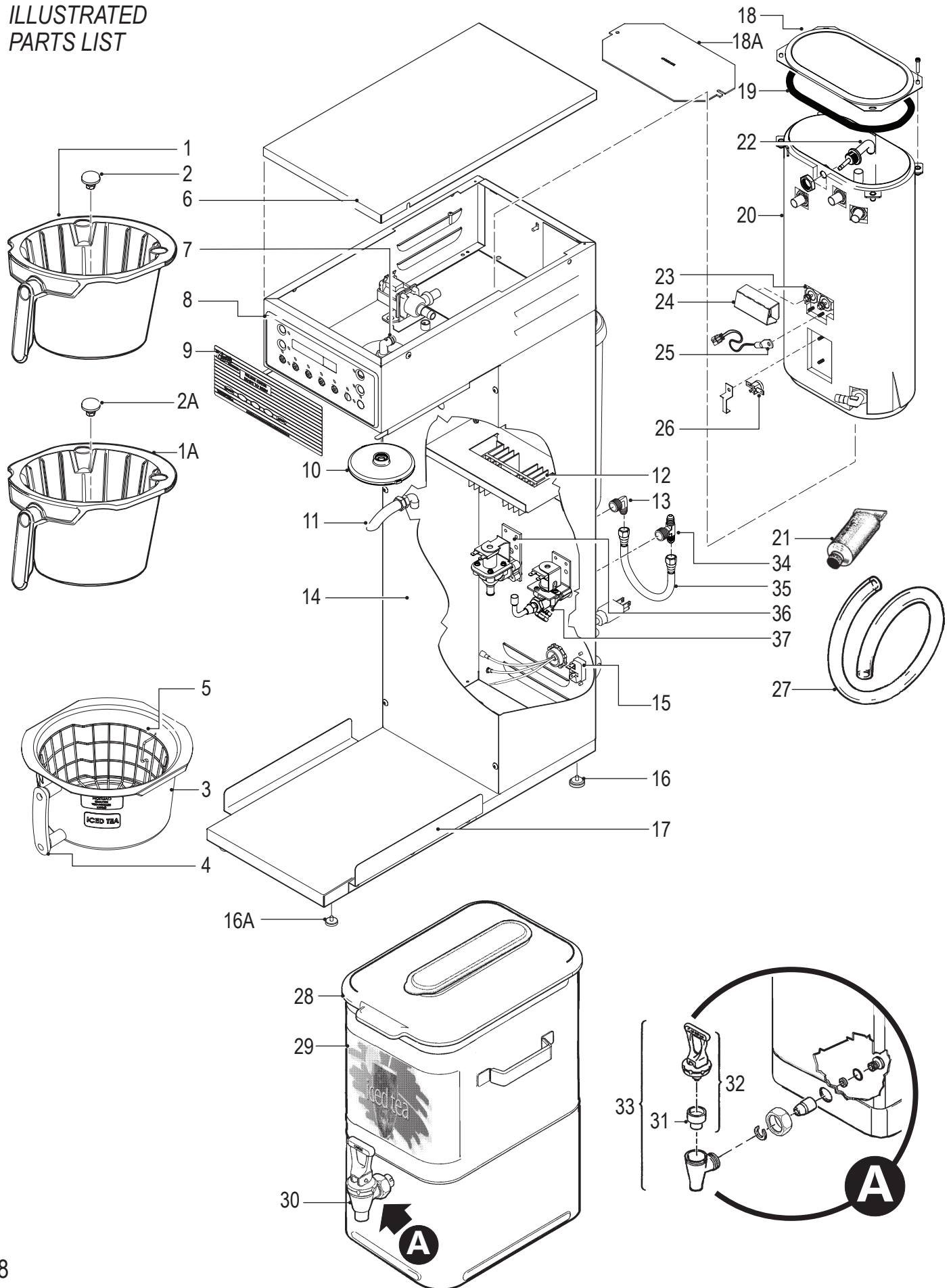

PARTS LIST

Illustrated Parts List - TCTS/T

ITEM	PART N ^o	DESCRIPTION
1	WC-37256	KIT, BREW CONE GOURMET PLASTIC FOR TEA UNITS
1A	WC-37239	KIT, BREW CONE GOURMET PLASTIC (PARADISE TEA)
2	WC-3647	STRAINER BT-10 BREWCONE TEA UNITS
2A	WC-8532	STRAINER, BREWCONE (PARADISE TEA)
3	WC-33001-101	BREWCONE ASSY, TEA W/STRAINER (OPTIONAL)
4	WC-3201	HANDLE, BREW CONE BLACK (FOR WC-33001-101)
5	WC-3353	WIRE BASKET, LARGE CAPACITY (OPTIONAL)
6	WC-58117	COVER, TOP BREWER
7	WC-2977-101	FITTING ASSY, SPRAYHEAD W/O-RING
8	WC-37276*	UCM KIT, LABEL & OVERLAY 120V TCTS/T
9	WC-39600*	LABEL, UCM OVERLAY TCT SWEET TEA CURTIS LOGO
9A	WC-39683	LABEL, UCM OVERLAY SWEET W/HALF BATCH CURTIS
10	WC-29025*	SPRAYHEAD, PURPLE ADVANCE FLOW
10A	WC-2942	SPRAYHEAD, GRAY (OLDER UNITS)
11	WC-2965	SPOUT, BYPASS ASSEMBLY
12	WC-8556*	HEAT SINK ASSY DV
13	WC-2401	ELBOW, 3/8 NPT X 1/4 FLRE PLTD
14	WC-58017	COVER, CENTER WRAP TCTS TCTDP-35S
14A	WC-58021	COVER, FRONT CENTER WRAP TCTT/TCTD-35
15	WC- 102*	SWITCH, TOGGLE SPST 25A 125/250VAC RESISTIVE
16	WC-3518	LEG, GLIDE 3/8"-16 STUD SCREW
16A	WC-3503	LEG, 8-32 STD SCREW BUMPER

ITEM	PART N ^o	DESCRIPTION
17	WC-8531	RAIL, BASE TCTD
18	WC-5853-102	COVER, TOP HEATING TANK GEN USE
18A	WC-5851	COVER, TANK W NOTCHES (MADE BEFORE 4/08)
19	WC-43062	GASKET, TANK LID
20	WC-6277	TANK ASSY, COMPLETE TEA BREWER
21	WC-5231*	COMPOUND SILICONE 5 OZ
22	WC-37278*	PROBE ASSY, W/HEX FITTING, O'RING & NUT
23	WC- 904-04*	ELEMENT, HEATING 1.6KW 120V W/JAM NUTS
24	WC-4394	SHOCK GUARD, HEATING ELEMENT
25	WC-1438-101*	SENSOR, TEMPERATURE TANK
26	WC- 521*	THERMOSTAT, HIGH LIMIT
27	WC-5310*	TUBING, 5/16" ID X 1/8" W SILICONE
28	WC-5683	LID ASSY, TCO
29	WC-38471	LABEL, FRONT TCO-308, TCO417, TCO419, TCO421
30	WC-1803	FAUCET, SPB
31	WC-1805*	SEAT CUP, FAUCET S'
32	WC-3707*	KIT, REPAIR SPB FAUCET
33	WC-37260*	KIT, FAUCET W/ADAPTER COMPLETE
34	WC-2707	TEE, FLARE 1/4 x 1/4 x 3/8 BRASS
35	WC-53038	TUBE ASSY, FLEXIBLE 1/4 FLARE 11-1/8"
36	WC- 826L*	VALVE, INLET 1 GPM 120V 10W
37	WC- 801*	VALVE, INLET BRASS .50 GPM 120V 10W RU/WB

* Recommended parts to stock

PARTS LIST SWEET TEA DETAIL

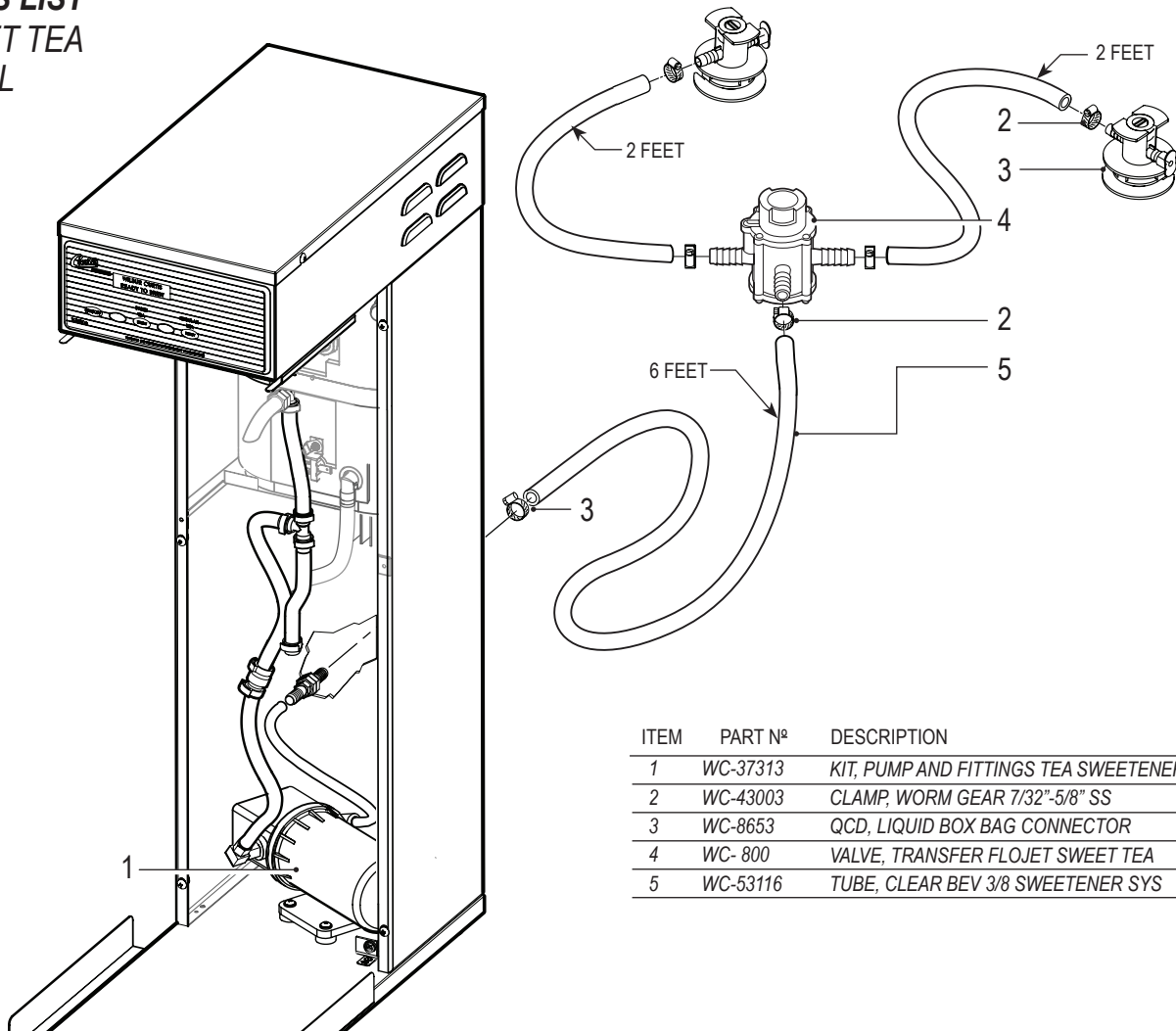

ITEM	PART N ^o	DESCRIPTION
1	WC-37313	KIT, PUMP AND FITTINGS TEA SWEETENER
2	WC-43003	CLAMP, WORM GEAR 7/32"-5/8" SS
3	WC-8653	QCD, LIQUID BOX BAG CONNECTOR
4	WC- 800	VALVE, TRANSFER FLOJET SWEET TEA
5	WC-53116	TUBE, CLEAR BEV 3/8 SWEETENER SYS

ELECTRICAL SCHEMATIC

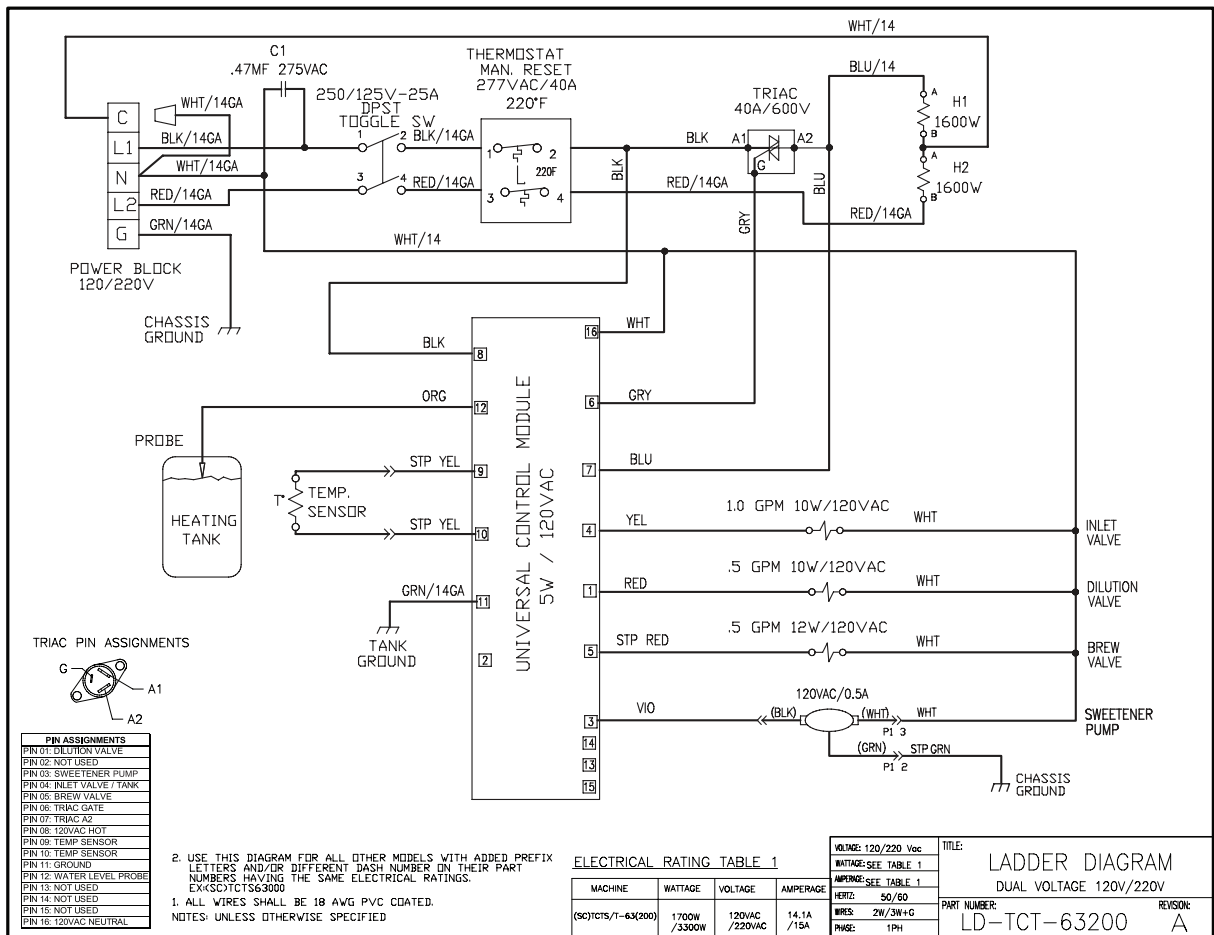
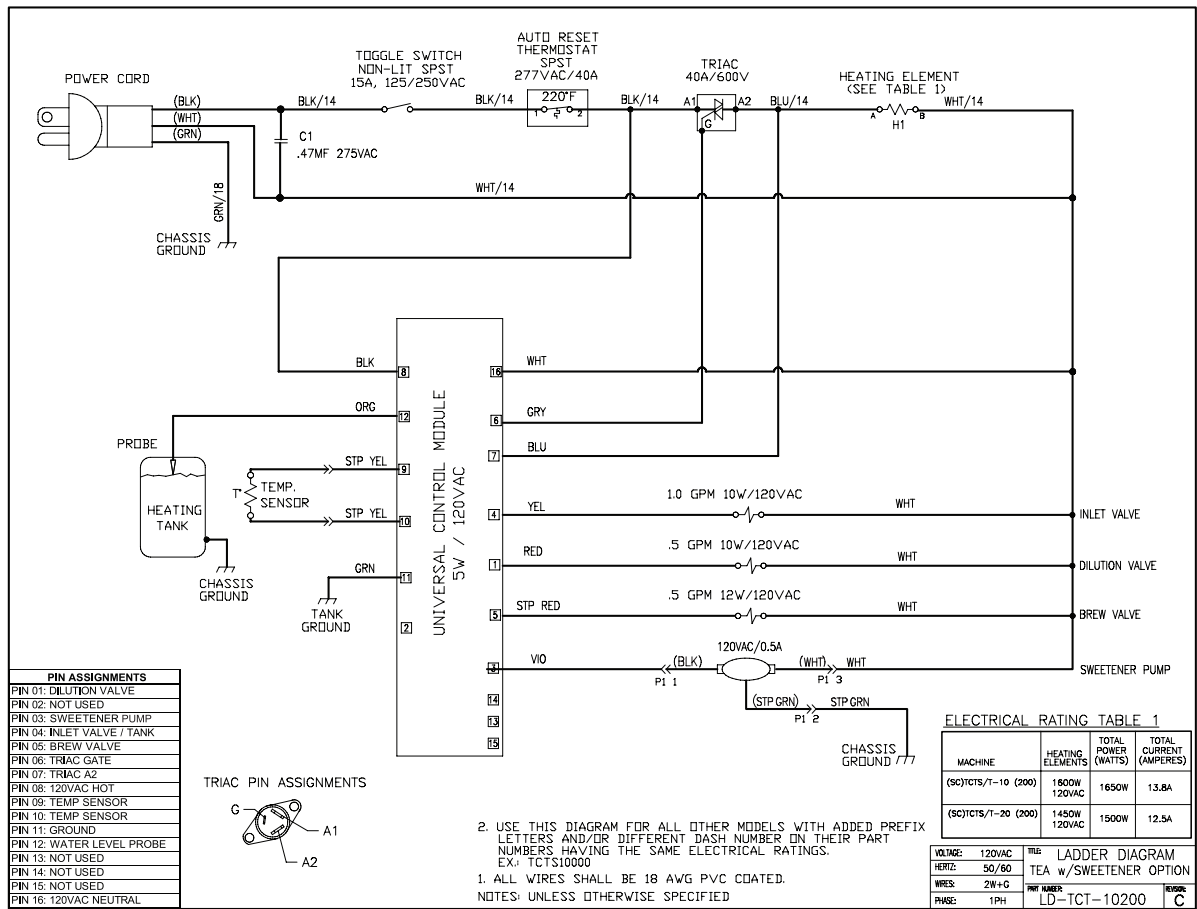

This page intentionally left blank.

Product Warranty Information

The Wilbur Curtis Company certifies that its products are free from defects in material and workmanship under normal use. The following limited warranties and conditions apply:

3 Years, Parts and Labor, from Original Date of Purchase on digital control boards.

2 Years, Parts, from Original Date of Purchase on all other electrical components, fittings and tubing.

1 Year, Labor, from Original Date of Purchase on all electrical components, fittings and tubing.

Additionally, the Wilbur Curtis Company warrants its Grinding Burrs for Forty (40) months from date of purchase or 40,000 pounds of coffee, whichever comes first. Stainless Steel components are warranted for two (2) years from date of purchase against leaking or pitting and replacement parts are warranted for ninety (90) days from date of purchase or for the remainder of the limited warranty period of the equipment in which the component is installed.

All in-warranty service calls must have prior authorization. For Authorization, call the Technical Support Department at 1-800-995-0417. Effective date of this policy is April 1, 2003.

Additional conditions may apply. Go to www.wilburcurtis.com to view the full product warranty information.

CONDITIONS & EXCEPTIONS

The warranty covers original equipment at time of purchase only. The Wilbur Curtis Company, Inc., assumes no responsibility for substitute replacement parts installed on Curtis equipment that have not been purchased from the Wilbur Curtis Company, Inc. The Wilbur Curtis Company will not accept any responsibility if the following conditions are not met. The warranty does not cover and is void under the following circumstances:

- 1) Improper operation of equipment: The equipment must be used for its designed and intended purpose and function.
- 2) Improper installation of equipment: This equipment must be installed by a professional technician and must comply with all local electrical, mechanical and plumbing codes.
- 3) Improper voltage: Equipment must be installed at the voltage stated on the serial plate supplied with this equipment.
- 4) Improper water supply: This includes, but is not limited to, excessive or low water pressure, and inadequate or fluctuating water flow rate.
- 5) Adjustments and cleaning: The resetting of safety thermostats and circuit breakers, programming and temperature adjustments are the responsibility of the equipment owner. The owner is responsible for proper cleaning and regular maintenance of this equipment.
- 6) Damaged in transit: Equipment damaged in transit is the responsibility of the freight company and a claim should be made with the carrier.
- 7) Abuse or neglect (including failure to periodically clean or remove lime accumulations): Manufacturer is not responsible for variation in equipment operation due to excessive lime or local water conditions. The equipment must be maintained according to the manufacturer's recommendations.
- 8) Replacement of items subject to normal use and wear: This shall include, but is not limited to, light bulbs, shear disks, "0" rings, gaskets, silicone tube, canister assemblies, whipper chambers and plates, mixing bowls, agitation assemblies and whipper propellers.
- 9) Repairs and/or Replacements are subject to our decision that the workmanship or parts were faulty and the defects showed up under normal use. All labor shall be performed during regular working hours. Overtime charges are the responsibility of the owner. Charges incurred by delays, waiting time, or operating restrictions that hinder the service technician's ability to perform service is the responsibility of the owner of the equipment. This includes institutional and correctional facilities. The Wilbur Curtis Company will allow up to 100 miles, round trip, per in-warranty service call.

RETURN MERCHANDISE AUTHORIZATION: All claims under this warranty must be submitted to the Wilbur Curtis Company Technical Support Department prior to performing any repair work or return of this equipment to the factory. All returned equipment must be repackaged properly in the original carton. No units will be accepted if they are damaged in transit due to improper packaging. **NO UNITS OR PARTS WILL BE ACCEPTED WITHOUT A RETURN MERCHANDISE AUTHORIZATION (RMA). RMA NUMBER MUST BE MARKED ON THE CARTON OR SHIPPING LABEL.** All in-warranty service calls must be performed by an authorized service agent. Call the Wilbur Curtis Technical Support Department to find an agent near you.



WILBUR CURTIS CO., INC.

6913 Acco St., Montebello, CA 90640-5403 USA

Phone: 800/421-6150 ♦ Fax: 323-837-2410

♦ Technical Support Phone: 800/995-0417 (M-F 5:30A - 4:00P PST) ♦ E-Mail: techsupport@wilburcurtis.com

♦ Web Site: www.wilburcurtis.com

FOR THE LATEST SPECIFICATION INFORMATION GO TO WWW.WILBURCURTIS.COM