



INSTRUCTIONS AND PARTS LIST TCN SERIES ICED TEA DISPENSERS



WARNING:

- Clean the dispenser completely before using it for the first time according to the DAILY CLEANING INSTRUCTIONS (back). Clean it regularly as instructed in the DAILY CLEANING INSTRUCTIONS.
- This product can expose you to chemicals including Acrylamide and Bisphenol A (BPA), which are known to the State of California to cause cancer and birth defects or other reproductive harm. For more information visit www.P65Warnings.ca.gov.

PARTS LIST

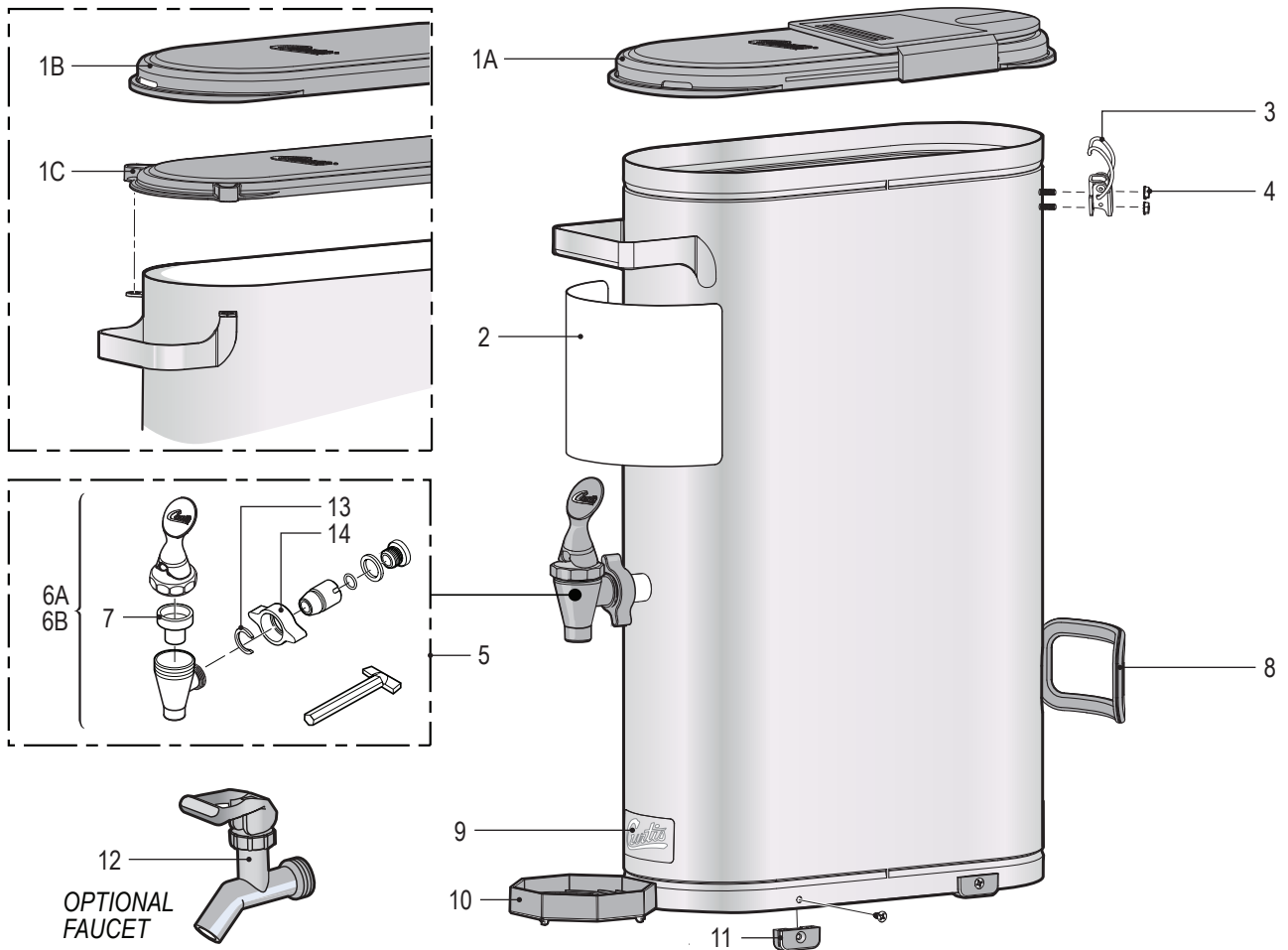

ITEM #	PART #	DESCRIPTION
1A	WC-56052	LID, BREW ASSY THROUGH TCN
1B	WC-56081	LID, LATCHABLE TCNL
1C	WC-61436	LID, PLASTIC TCN (OLD)
2	WC-38471	LABEL, FRONT TCO ICED TEA GENERIC
3	WC-3276*	LATCH, DRAW ZINC PLATED STEEL TCN200
4	WC-4263*	NUT, 6-32 X 1/4 OD HEX W/WASHER KEPS
5	WC-37260**	KIT, FAUCET W/ADAPTER COMPLETE TC/TT
6A	WC-1803	FAUCET, "SPB" SERIES, BLACK HANDLE/ PLASTIC 1-1/32-14 UNS CURT
6B	WC-1865	FAUCET, "SPB" SERIES BLK PLST SWEETENED/UNSWEETENED (NOT SHOWN)

ITEM #	PART #	DESCRIPTION
7	WC-1805	SEAT CUP, "S" FAUCET USE ON WC-1800/B/LB/D/DL/L/WC-1803
8	WC-3289	HANDLE, GASKET TCN
9	WC-38163	LABEL, CURTIS LOGO WHITE TRANSFER
10	WC-5686	DRIP TRAY, OCTAGON STYLE
11	WC-3531	LEG, PLASTIC GLIDE TCN
12	WC-1840	FAUCET, PINCH TUBE TC
13	WC-1906	"C" RG .917 X .760 X .090 TT-3 TC'S
14	WC-1905	NUT, WING PLASTIC 1-1/32-14UNF (TC-2,3,5,10)

* Used on TCNL series only.

**For units manufactured before 03/01/2017.

DAILY CLEANING INSTRUCTIONS

⚠ NOTICE: Do not use cleaning liquids, compounds or powders containing chlorine (bleach) or corrosives. These products promote corrosion and will damage the finishes. USE OF THESE PRODUCTS WILL VOID THE WARRANTY.

Cleaning the Container

- 1 Prepare a mild solution of detergent and warm water. Remove the container from the brewer and remove the lid. Rinse.
- 2 **Wash** - Wipe the exterior surfaces with a sponge and the detergent solution to remove spills and debris. Use the detergent solution and a soft bristled brush to wash the inside of the container.
- 3 **Rinse** - Rinse with clean, warm water.
- 4 **Sanitize*** - Sanitize the interior of the container using a commercial sanitizer suitable for food grade applications. Sanitize according to the directions on the package.

* If a three compartment sink large enough to submerge the container is not available, swab, brush or pressure spray the sanitizing solution according to the directions on the package.
- 5 **Air Dry** - Turn the container upside down and allow to air dry.

Cleaning the Faucet Parts and Lid

- 1 Disassemble the faucet - Unscrew the faucet assembly from the container. Then, unscrew the handle/bonnet assembly from the top of the faucet and remove. Inspect the seat cup for wear. Replace the seat cup if it is damaged.
- 2 **Wash** - Wash the lid and faucet parts with the detergent solution.
- 3 **Rinse** - Thoroughly rinse all parts with clean, warm water.
- 4 **Sanitize** - After rinsing, place the faucet parts in the sink to be sanitized. Immerse them in a commercial sanitizer suitable for food grade applications. Sanitize according to the directions on the package.
- 5 **Air Dry** - Allow all parts to thoroughly air dry.
- 6 Reassemble - When dry, reassemble the handle/bonnet. Hand tighten the handle/bonnet onto the top of the faucet assembly. Hand-tighten the faucet assembly onto the container outlet. Curtis recommends wiping down the outside surfaces with stainless steel polish after cleaning for a polished look and to prevent scratches.

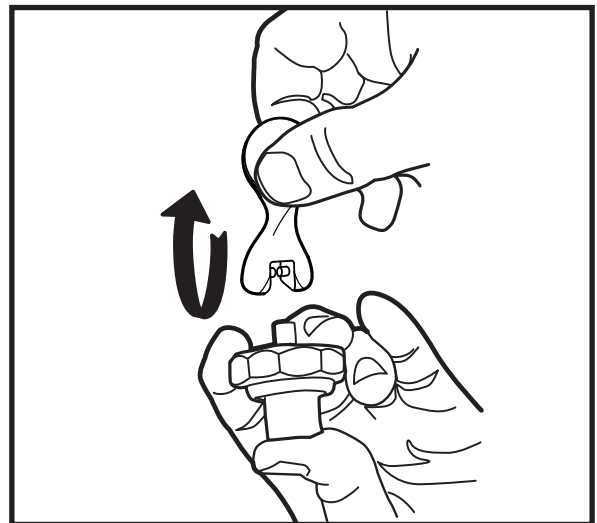

To dis-assemble the top of the faucet, grasp the bonnet and push up on the seat cup, while unhooking the handle.

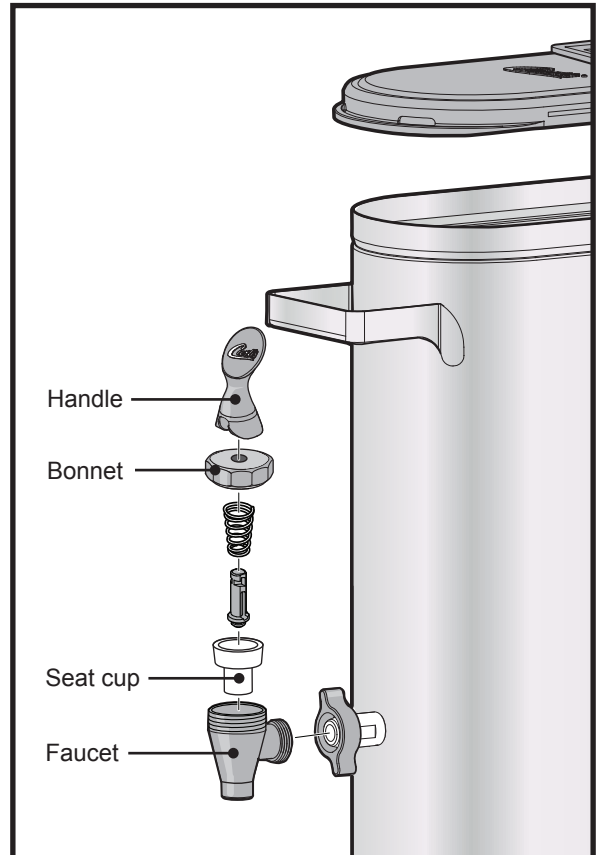

09/2018 F-3639 revL



Wilbur Curtis Co., Inc.

Mail: 6913 Acco Street, Montebello, CA 90640-5403 U.S.A.

Phone: 800-421-6150 | Fax: 323-837-2410 | Technical Support Phone: 800-995-0417 (M-F 5:30 A.M. - 4:00 P.M. PST)

Email: techsupport@wilburcurtis.com

www.wilburcurtis.com