

## MCD-7 & MCD-7G Instructions & Service Information

Revised: May 2002

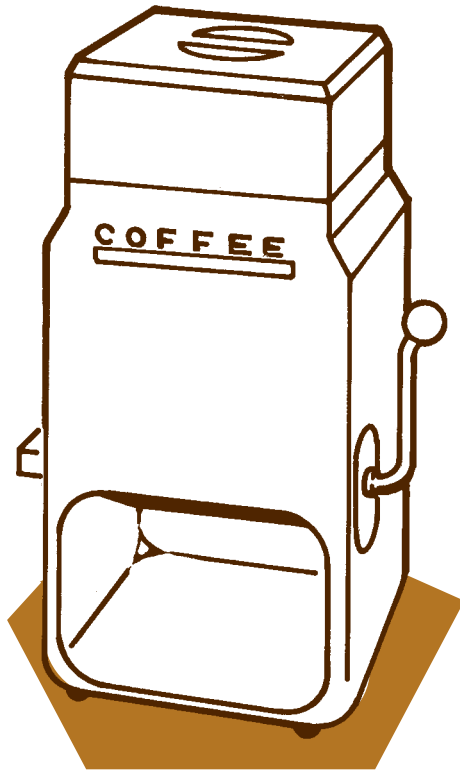

MCD-7G

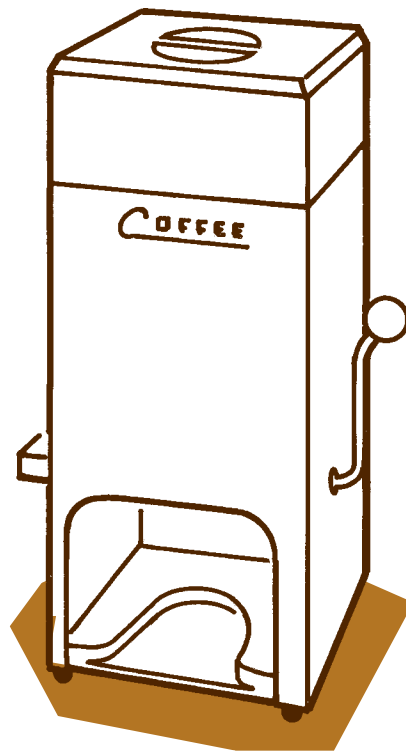

MCD-7

### MEASURED COFFEE DISPENSERS

---

**WILBUR CURTIS CO., INC.**

6913 Acco St., Montebello, CA 90640-5403 USA

Phone: 800/421-6150 ♦ Fax: 323-837-2410

♦ Technical Service Phone: 800/995-0417 (M-F 5:30A - 4:00P PST)

♦ E-Mail: [techservice@wilburcurtis.com](mailto:techservice@wilburcurtis.com)

♦ Web Site: [www.wilburcurtis.com](http://www.wilburcurtis.com)

FOR THE LATEST SPECIFICATION INFORMATION GO TO [WWW.WILBURCURTIS.COM](http://WWW.WILBURCURTIS.COM)

---

## FOAM INSERTS — INSTALLATION

1. Remove lid. Remove bag of inserts.
2. Looking down into the hopper, observe the small nylon pin piercing the left side of the measuring drum.
3. Now turn unit on its back (see Figure 1.).
4. Using a knife blade or thin screw driver, slide the blade under the head of the pin and pry out the nylon pin.
5. Pull handle to DOWN position and carefully, place into drum opening, one of the foam inserts (as shown in Figure 2.). Each insert is marked with the quantity, in ounces, that it will dispense (the smaller the insert, the more coffee dispensed from the unit).
6. Replace nylon pin. Press firmly on the head until it snaps into place.
7. Turn the unit upright and fill the hopper with ground coffee. The coffee dispenser is now ready for use.

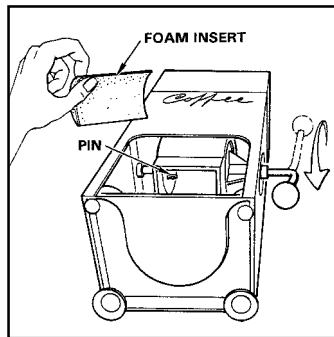

Figure 1. View of MCD-7, looking into drum from beneath.

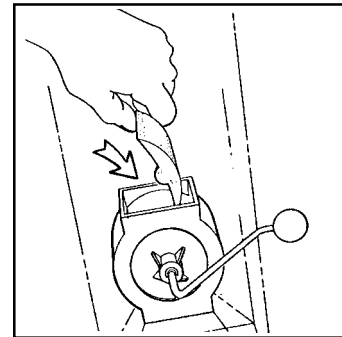

Figure 2. View placing foam inserts into drum.

---

## OPERATION OF MCD-7

1. Place a coffee filter or a Brew Basket with filter already inserted. Fit it, into the front opening of the MCD-7.
2. Pulling the handle will dispense the amount of coffee you have selected with the foam insert. If you need to change the quantity of ground coffee that is dispensed (see FOAM INSERTS INSTALLATION, above) choose a different size of insert.

---

## REPLACING THE HANDLE RETURN SPRING

With use, the handle return spring occasionally breaks. If this happens, the handle will no longer automatically lift after pulling down. When this happens, the MCD-7 is still usable by simply by lifting up the handle to the top position after each dispense stroke. The spring can be replaced. Using the illustrated parts breakdown as a guide will help identify the parts referred to in these instructions. The index numbers in parentheses ( ) will match those in the parts breakdown.

1. Remove the hopper. The hopper is held in place by a screw (5) and nut (6) on both sides of the upper of hopper.
2. Remove the round black knob (21) on the handle. Unthread it, twisting counterclockwise.
3. Remove the bottom screw (9) on the side plate (don't lose the arm stop (7) that it screws into). Also, on the side plate (8), remove the top screw and the other stop (7) that it is threaded into. Take off the side plate.
4. The next step is to remove the drum and shaft assembly (10). To do this, lay the unit on it's side with the handle pointing up. Grab the handle (20) with your right hand. Reach inside the MCD-7 and push against the opposite wall with the flat of your left hand while with your right hand you pull up on the handle (figure 3.). The walls are flexible enough so that with a little tugging you can dislodge the shaft from the hole in the left side of the wall.
5. Once free, pull the handle through the hole on the right side of the MCD-7 (fig 4.) and lift out the drum and shaft.
6. To get off the broken return spring (17), you will have to separate the handle from the plastic drum. The easiest way is to clamp the metal handle in a vise, grab the drum with both hands; then just yank off the drum with a firm tug.

## REPLACING THE HANDLE RETURN SPRING, CONT'D

7. Take off the collar by loosening the set screw with an Allen wrench. Take notice of the spring position.

9. Replace with a new spring and reverse steps 4 through 7 to reinstall the drum.

10. The drum assembly should be in place with the handle sticking out from the hole on the right side of the MCD-7. Slide the side plate through the handle and align the screw holes. Rotate the handle so that it is pointing down. Reaching in from the top, push the end of the spring through the side hole on the spring retainer (7). Hold on to these while rotating them (put tension on the spring) to align with the top screw hole. Insert the screw from the outside, through the plate and into the threaded retainer. Thread the screw into the spring retainer loosely (not tight).

11. Rotate the handle counter clockwise until the stop bar (19) hits the spring retainer. Hold the handle in this position while replacing the arm stop standoff and screw on the bottom hole of the plate. Release the handle. The return spring will now have the proper tension to return the handle when pulled. The travel of the handle is also limited by the stop bar between the standoff and the spring retainer. Tighten the screw on the spring retainer.

12. Replace the knob on the handle and put the hopper back on.

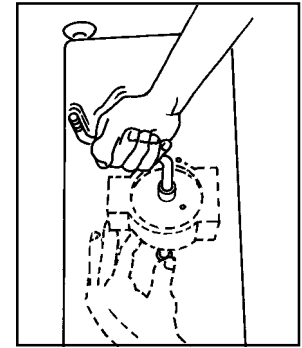

Figure 3.

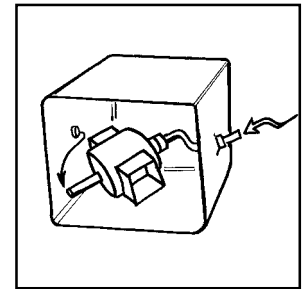
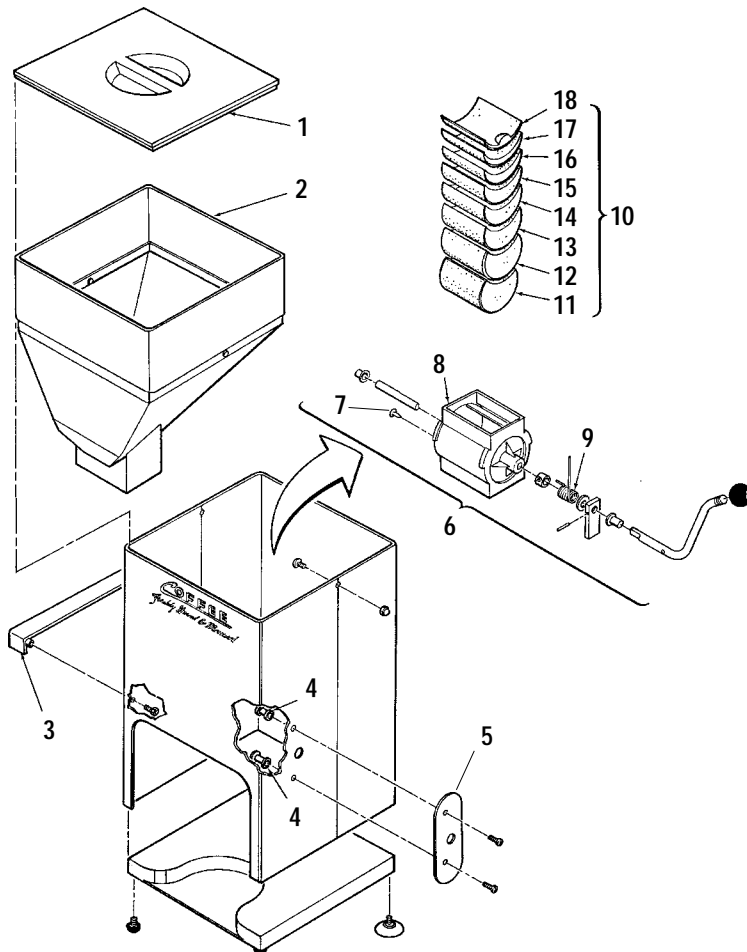

Figure 4

## ILLUSTRATED PARTS LIST



Note: This parts list contains parts that are common to both the MCD-7 and MCD-7G units, except where noted, indication in bold type.

INDEX NO.	PART NO.	DESCRIPTION
1	WC-3612	COVER, COFFEE HOPPER MCD-7
1A	WC-3666	COVER, GRAY HOPPER MCD-7G
2	WC-3610	HOPPER, COFFEE MCD-7
2A	WC-3667	HOPPER, GRAY COFFEE MCD-7G
3	WC-3606	GUARD, HEAT MCD-7
4	WC-4004	STOP, ARM
5	WC-5408	PLATE, SIDE
6	WC-3673	DRUM & HANDLE REG COMPLETE MCD-7
6A	WC-3674	DRUM & HNDL LG GRAY COMPL MCD-7G
7	WC-4806	PIN, CANOE (10 PER PKG.)
8	WC-3601	DRUM ASSY W/SHAFT & RINGS MCD-7
8A	WC-3671	DRUM ASSY GRAY MCD-7G
9	WC-3400	SPRING, RETURN
10	WC-3614	DRUM INSERTS (SET OF 8)
11	WC-3622	FOAM INSERT (1.25 oz.) #125
12	WC-3623	FOAM INSERT (1.50 oz.) #150
13	WC-3624	FOAM INSERT (1.75 oz.) #175
14	WC-3625	FOAM INSERT (2 oz.) #200
15	WC-3626	FOAM INSERT (2.25 oz.) #225
16	WC-3627	FOAM INSERT (2.50 oz.) #250
17	WC-3628	FOAM INSERT (2.75 oz.) #275
18	WC-3629	FOAM INSERT (3 oz.) #300

**WARRANTY** We hereby certify that the products manufactured by the Wilbur Curtis Company, Inc., are, to the best of our knowledge, free from all defects and faulty workmanship.

The following warranties and conditions are applicable:

- **90 Days for Labor and 1 Year Parts from Date of Purchase from Factory:** This warranty covers all electrical parts, fittings and tubing.
- **40 Months or 40,000 Pounds of Coffee on a set of Grinding Burrs. (ADS Grinders)**
- **2 Years from Date of Purchase:** This warranty covers electronic control boards and leaking or pitting of a stainless steel body of a Brewer or Urn.
- **90 Days from Date of Purchase:** On replacement parts that have been installed on out of warranty equipment

All in-warranty service calls must have prior authorization from the manufacturer. For an RMA (Return Merchandise Authorization) number, call the Technical Service Department at 1-800-995-0417. The Wilbur Curtis Company will allow up to 100 miles, round trip, per in-warranty service call.

**CONDITIONS & EXCEPTIONS**

The warranty covers original equipment at time of purchase only. The Wilbur Curtis Company, Inc., assumes no responsibility for substitute replacement parts installed on Curtis equipment that have not been purchased from the Wilbur Curtis Company, Inc. The Wilbur Curtis Company will not accept any responsibility if the following conditions are not met. The warranty does not cover and is void under these circumstances:

- 1) **Improper operation of equipment. The equipment must be used for its designed and intended purpose and function.**
- 2) **Improper installation of equipment. This equipment must be installed by a professional, certified technician and must comply with all local electrical, mechanical and plumbing codes.**
- 3) **Wilbur Curtis Company will not be responsible for the operation of equipment at other than the stated voltages on the serial plate.**
- 4) **Abuse or neglect (including failure to periodically clean or remove lime accumulations). Manufacturer is not responsible for variation in equipment operation due to excessive lime or local water conditions.**
- 5) **Replacement of items subject to normal use and wear. This shall include, but is not limited to, light bulbs, shear disks, "O" rings, gaskets, canister assemblies, whipper chambers and plates, mixing bowls, agitation assemblies and whipper propellers.**
- 6) **Any faults resulting from inadequate water supply. This includes, but is not limited to, excessive or low water pressure, and inadequate or fluctuating water flow rate.**
- 7) **All repairs and/or replacements are subject to our decision that the workmanship or parts were faulty and the defects showed up under normal use.**
- 8) **All labor shall be performed during regular working hours. Overtime charges are the responsibility of the owner.**
- 9) **Charges incurred by delays, waiting time, or operating restrictions that hinder the service technician's ability to perform service is the responsibility of the owner of the equipment.**  
*This includes institutional and correctional facilities.*
- 10) **All claims under this warranty must be submitted to the Wilbur Curtis Company Technical Service Department before return of the unit to the factory.**
- 11) **All equipment returned to us must be repackaged properly in the original carton. No units will be accepted if they are damaged in transit due to improper packaging.**
- 12) **Damaged in transit.**
- 13) **The resetting of safety thermostats and circuit breakers, programming and temperature adjustments are the responsibility of the equipment owner.**

**NO UNITS OR PARTS WILL BE ACCEPTED WITHOUT A RETURN MERCHANDISE AUTHORIZATION (RMA). RMA NUMBER MUST BE MARKED ON THE CARTON OR SHIPPING LABEL.**

All in-warranty service calls must be performed by an authorized service center, where service is available. Call the factory for location near you.



**WILBUR CURTIS CO., INC.**

6913 Acco St., Montebello, CA 90640-5403 USA

Phone: 800/421-6150 ♦ Fax: 323-837-2410

♦ Technical Service Phone: 800/995-0417 (M-F 5:30A - 4:00P PST) ♦ E-Mail: [techservice@wilburcurtis.com](mailto:techservice@wilburcurtis.com)

♦ Web Site: [www.wilburcurtis.com](http://www.wilburcurtis.com)