



G3 Gemini® IntelliFresh® Series Coffee Brewing System



READ AND SAVE THESE INSTRUCTIONS

NOTICE TO INSTALLER: Please leave this booklet with the machine.

Key Features/Specifications/System Requirements..... FS2

Important Safeguards IS2

Installation Instructions (General).....II2

Installation Instructions (Leveling, Water Supply, Electrical).....II1

Operating InstructionsOI1

IntelliFresh® Features..... IF1

Cleaning Instructions (Brewer) CI1

Cleaning Instructions (Satellite)..... CI3

Programming Guide PG2

Rough-In Drawing (Brewer)..... RD2

Rough-In Drawing (Satellite) RD75

Illustrated Parts/Recommended Parts (Main Chassis)..... IP2

Illustrated Parts/Recommended Parts (Tank Assembly, Twin) IP26

Illustrated Parts/Recommended Parts (Tank Assembly, Single)..... IP31

Illustrated Parts/Recommended Parts (Tank Assembly, Single, Dual Voltage) IP32

Electrical Schematic (GEMSIF10A1000, GEMSIF10B1000) ES2

Electrical Schematic (GEMSIF63A1000).....ES3

Electrical Schematic (GEMSIF30A1000).....ES4

Electrical Schematic (GEMTIF10A1000, GEMTIF10A2000, GEMTIF10B1000).....ES5

Electrical Schematic (GEMTIF30A1000).....ES6

Electrical Schematic (GEM3IF)ES29

Electrical Schematic (GEM3IF-30)ES30

Troubleshooting Guide (General).....TG5

Troubleshooting Guide (SSR Circuit)TG9

Troubleshooting Guide (Warmer Circuit).....TG13

Error CodesEC4

Product Warranty.....PW1

Contact Information

Wilbur Curtis Co., Inc.

6913 Acco Street | Montebello, CA 90640 US
 Phone: 323-837-2300 | Toll Free: 800-421-6150
 Email: csrcassistance@wilburcurtis.com | Web: www.wilburcurtis.com

For the latest specifications and information go to www.wilburcurtis.com
 Toll Free: 800-995-0417 | Monday - Friday 5:30 A.M. - 4:00 P.M. PT
 Email: techsupport@wilburcurtis.com

Due to continued product improvement, the products illustrated/photographed in this guide may vary slightly from the actual product.

Key Features

- LED notification of freshness timing.
- Gold Cup Series™ – digital control module provides precise control over all aspects of brewing: time, temperature, volume plus specialty coffee needs from pre-infusion to pulse-brewing to water bypass.
- Preset, one-touch Global Recipes – Based on coffee type, grind and weight. Simplifies profile setting for gourmet results every time.
- Industry's most effective mineral tolerant design.
- Patented fast-wetting AFS spray head and non-immersed water temperature sensor.
- Encapsulated control board – Protects against steam, water and impact.
- Field selectable for 0.5, 1.0 or 1.5 gal. batch brewing.

Specifications (Selected Models)

Electrical Supply Requirements

MODEL #	DESCRIPTION	PHASE	VOLTS	AMPS	HEATING CONFIG	WIRE	WATTS	HERTZ	GAL/HR
GEMSIF10A1000	Single, 1.5 Gallon with IntelliFresh	1 PH	220 V	18.5 A	2 X 2000 W	3W + G	4050 W	50/60 Hz	12.0
GEMTIF10A1000/ GEMTIF10A2000	Twin, 1.5 Gallon with IntelliFresh	1 PH	220 V	23.0/34.0 A	3 X 2500 W	3W + G	5100/7500 W	50/60 Hz	15.0/21.0
GEMSIF63A1000	Single, 1.5 Gallon w/IntelliFresh, DV	1 PH	120/220 V	13.5/13.5 A	2 X 1600 W	2/3W + G	1650/2800 W	50/60 Hz	4.5/10.0
GEMSIF10B1000	Single, 1.5 Gallon with IntelliFresh, Black	1 PH	220 V	18.5 A	2 X 2000 W	3W + G	4050 W	50/60 Hz	12.0
GEMTIF10B1000	Twin, 1.5 Gallon with IntelliFresh, Black	1 PH	220 V	23.0/34.0 A	3 X 2500 W	3W + G	5100/7500 W	50/60 Hz	15.0/21.0

EXPORT

GEMSIF30A1000	Single, 1.5 Gallon with IntelliFresh	1 PH	230 V	18.5 A	2 X 2000 W	2W + G	4050 W	50/60 Hz	12.0
GEMTIF30A1000	Twin, 1.5 Gallon with IntelliFresh	1 PH	230 V	23.0 A	2 X 2500W	2W + G	5574 W	50/60 Hz	15.0/21.0

Dimensions

MODEL #	HEIGHT	WIDTH	DEPTH	SHIP WEIGHT	SHIP CUBE	WATER CONNECTOR	WATER PRESSURE	MIN. FLOW RATE
GEMSIF10A1000	30.58"	9.11"	22.39"	51.0 lbs	7.00 cu ft	3/8" flare	20 - 90 psi	1.0 gpm
GEMTIF10A1000	30.83"	18.11"	22.39"	85.0 lbs	10.85 cu ft	3/8" flare	20 - 90 psi	2.0 gpm
GEMSIF63A1000	30.58"	9.11"	22.39"	51.0 lbs	7.00 cu ft	3/8" flare	20 - 90 psi	1.0 gpm
GEMSIF10B1000	30.58"	9.11"	22.39"	51.0 lbs	7.00 cu ft	3/8" flare	20 - 90 psi	1.0 gpm
GEMTIF10B1000	30.83"	18.11"	22.39"	85.0 lbs	10.85 cu ft	3/8" flare	20 - 90 psi	2.0 gpm

EXPORT

GEMSIF30A1000	30.58"	9.11"	22.39"	51.0 lbs	7.00 cu ft	3/8" flare	20 - 90 psi	1.0 gpm
GEMTIF30A1000	30.83"	18.11"	22.39"	85.0 lbs	10.85 cu ft	3/8" flare	20 - 90 psi	2.0 gpm

Following are the factory default settings for the IntelliFresh brewer:

- Brew Temperature = 200°F
- Water Bypass = On LARGE and MEDIUM brew only
- Brew Volume = Large-Medium-Small
- Energy Save Mode = Off
- Quality Timer = 120 Minutes
- Warmer Auto-Off = 10 Hours

Symbols



This is the safety alert symbol. It is used to alert you to potential physical injury hazards. Obey all safety messages that follow this symbol to avoid possible injury or death.



DANGER - Indicates a hazardous situation which, if not avoided, will result in death or serious injury.



WARNING - Indicates a hazardous situation which, if not avoided, could result in death or serious injury.



CAUTION - Indicates a hazardous situation which, if not avoided, could result in minor or moderate injury.



NOTICE - Indicates a situation which, if not avoided, could result in property damage.



IMPORTANT - Provides information and tips for proper operation.



SANITATION REQUIREMENTS



WARNING - This product can expose you to chemicals including Acrylamide and Bisphenol A (BPA), which are known to the State of California to cause cancer and birth defects or other reproductive harm. For more information visit www.P65Warnings.ca.gov.

Important Safeguards/Conventions



WARNING:

- Make sure that this appliance is installed and grounded according to the INSTALLATION INSTRUCTIONS by qualified personnel before attempting to use it. Failure to follow the INSTALLATION INSTRUCTIONS could result in personal injury or void the warranty.
- This appliance is designed for commercial use. Any service other than cleaning and preventive maintenance should be performed by an authorized Wilbur Curtis service technician.
- To reduce the risk of fire or electric shock, DO NOT open the service panels. There are no user serviceable parts inside.
- Keep hands, arms and other items away from hot surfaces of the unit during operation.
- Clean the appliance and any dispensers completely before using them for the first time according to the CLEANING INSTRUCTIONS. Clean them regularly as instructed in the CLEANING INSTRUCTIONS.
- Use this appliance only for its intended use, brewing/dispensing hot and/or cold beverages/water.
- This appliance is not intended for use by persons (including children) with reduced physical, sensory or mental capabilities or lack of experience and knowledge, unless they have been given supervision or instruction concerning use of the appliance by a person responsible for their safety. Children should be supervised to ensure that they do not play with the appliance.
- Avoid spillage onto the power (mains) connector.

CE Requirements

- This appliance must be installed in locations where it can be overseen by trained personnel.
- For proper operation, this appliance must be installed where the temperature is between 5°C to 35°C.
- Appliance shall not be tilted more than 10° for safe operation.
- An electrician must provide electrical service as specified in conformance with all local and national codes. For safe use, an all-pole disconnection must be incorporated into the fixed wiring in accordance with the wiring rules outlined in clause 7.12.2 of IEC 60335 for meeting the minimum electrical safety of this standard.
- This appliance must not be cleaned by water jet.
- This appliance can be used by persons aged from 18 years and above if they have been given supervision or instruction concerning use of the appliance in a safe way and if they understand the hazards involved.
- Keep the appliance and its cord out of reach of children aged less than 18 years.
- Appliances can be used by persons 18 years and above with reduced physical, sensory or mental capabilities or lack of experience and knowledge if they have been given supervision or instruction concerning use of the appliance in a safe way and understand the hazards involved.
- Children under the age of 18 years should be supervised to ensure they do not play with the appliance.
- If the power cord is ever damaged, it must be replaced by the manufacturer or authorized service personnel with a special cord available from the manufacturer or its authorized service personnel in order to avoid a hazard.
- Machine must not be immersed for cleaning.
- Cleaning and user maintenance shall not be made by children unless they are older than 18 years and supervised.
- This appliance is intended to be used in household and similar applications such as:
 - staff kitchen areas in shops, offices and other working environments;
 - by clients in hotels, motels and other residential type environments;
 - bed and breakfast type environments.
- This appliance not intended to be used in applications such as:
 - farm houses
- Access to the service areas permitted by Authorized Service personnel only.
- The A-Weighted sound pressure level is below 70 dBA.



WARNING: Installation is to be performed only by a qualified installer.



WARNING: Improper electrical connection may result in an electric shock hazard. This brewer must be properly grounded.



NOTICE: DO NOT connect this brewer to a hot water supply. The water inlet valve is not rated for hot water. Do not exceed the maximum water pressure stated in the *SPECIFICATIONS* section.



IMPORTANT: Observe all governing codes and ordinances.

Installation Instructions

Installation Requirements

- A secure surface capable of supporting the weight of the appliance.
- For units without an attached cord set: Appropriately sized, UL listed, grounding type power cable to meet the electrical specifications for the appliance. If you have questions about the correct cable size and length, consult a qualified installer. If the appliance will be hard wired to a junction box, the power cable must be long enough so that the unit can be moved for cleaning underneath.
- A grounded electrical connection to an electrical circuit that meets the electrical specifications of the appliance (see *SPECIFICATIONS*). The circuit must be protected by the appropriate sized circuit breaker. If you are not certain that the existing circuit meets the requirements for your unit, consult a licensed electrician.
- A water filtration system is required to maintain trouble-free operation. Wilbur Curtis Co., Inc. recommends a Wilbur Curtis approved water filter. See the Curtis Equipment Catalog for a full line of Wilbur Curtis approved water filters.
- Potable water supply line connection from the water filter capable of supplying the minimum flow rate required by the specifications. The water supply line must be able to connect to the flare fitting on the back of the unit. See the *SPECIFICATIONS* section for the correct size. The water line should also be capable of being controlled by a shut off valve. Do not connect the water line to a saddle valve or needle valve.



NSF International requires the following water connection:

- 1 A quick disconnect or additional coiled tubing (at least two times the depth of the appliance) is required so that it can be moved for cleaning underneath.
- 2 This equipment is to be installed with adequate back-flow protection to comply with applicable federal, state and local codes.
- 3 Water pipe connections and fixtures directly connected to a potable water supply shall be sized, installed and maintained in accordance with federal, state and local codes.

The International Plumbing Code of the International Code Council and the Food and Drug Administration (FDA) Food Code manual, direct that this equipment must be installed with adequate back-flow prevention in compliance with federal, state and local codes. For units installed outside of the U.S.A., make sure that the installation is in compliance with the applicable plumbing/sanitation code for your area.

Installation

Leveling



WARNING: Use the leveling legs to level the brewer only. Do not use them to adjust brewer height. Do not extend them higher than necessary.

- 1 Position the brewer on the counter top. Level it left to right and front to back by turning the bottom of the legs.

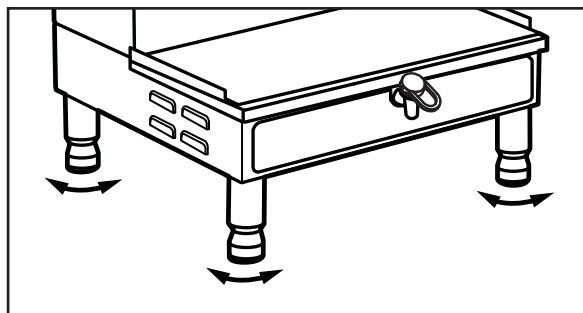

Connect the Water Supply

- 2 Flush the water supply line prior to installation to purge air and debris from the water filter and tubing.
- 3 Connect the water supply line to the flare fitting on the back of the brewer. Leave the water supply valve closed until the power is connected.



Connect the Brewer Wiring

Brewers Without A Cord Set Attached and Dual Voltage Brewers to be Operated 220 Volts



WARNING: Turn off power to the junction box at the circuit breaker panel before connecting the power cable to the brewer. Lock out and tag the circuit breaker.

- 4 Remove the screws that hold the front cover in place and remove the cover.
- 5 Loosen the strain relief on the back of the brewer.
- 6 On dual voltage units being operated at 220 Volts (nominal) disconnect the existing power cable from the terminal block and remove.
- 7 Feed the 220 Volt power cable into the brewer.
- 8 On dual voltage units being operated at 220 Volts, disconnect and cap the jumper wire between the “C” and “N” terminals on the terminal block.
- 9 Connect the wires on the power cable to the terminal block inside the brewer.
- 10 Tighten the strain relief and replace the front cover.
- 11 Connect the power cable wires to the terminals in the junction box. See the ELECTRICAL SCHEMATIC for the power supply requirements.

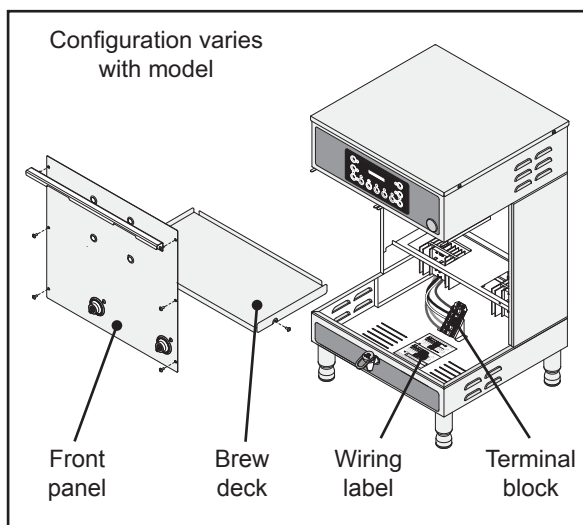

Connect the Brewer Wiring (cont.)

Brewers With A Cord Set Attached -

- 12 Connect the power cord to the appropriate type of electrical outlet.



WARNING: Connect the power cord to the appropriate type and size electrical outlet. If the electrical outlet is not compatible with the power cord, have it upgraded by a licensed electrician. Do not modify the power plug. Do not use an extension cord. Do not use a power cord/plug that is damaged.

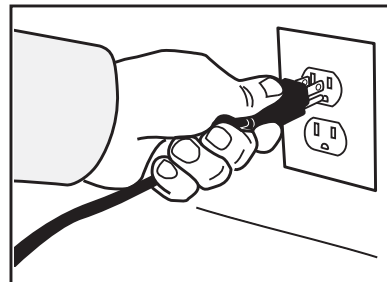

Power Up the Brewer

- 13 Turn on the water supply valve.
- 14 Make sure that the circuit breaker supplying power to the unit is on.
- 15 Turn the toggle switch on the back of the brewer to the ON position. The water tank will start to fill. While the tank is filling, inspect the water supply line for leaks.
- 16 Determine if the brewer will be setup for one, two or three batch mode. Find the appropriate label, included with the brewer. The three batch label has LARGE, MED and SMALL BREW on it, the two batch label has LARGE and SMALL BREW on it, and the one batch has only BREW on it.
- 17 Peel the protective backing off of the desired label and affix it to the front of the universal control module (UCM).
- 18 Go to the **PROGRAMMING GUIDE** section and program the brewer for the correct model and batch number.

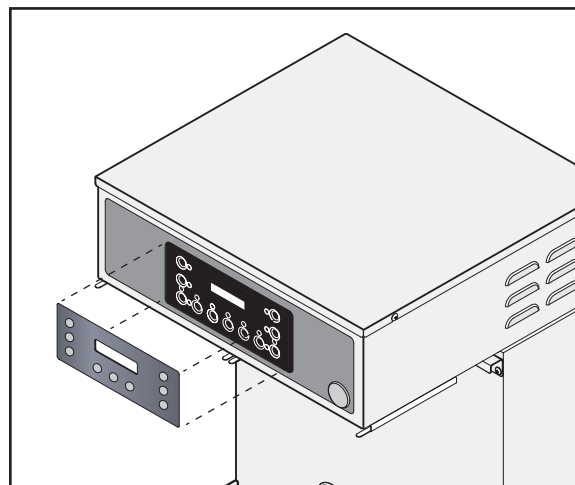
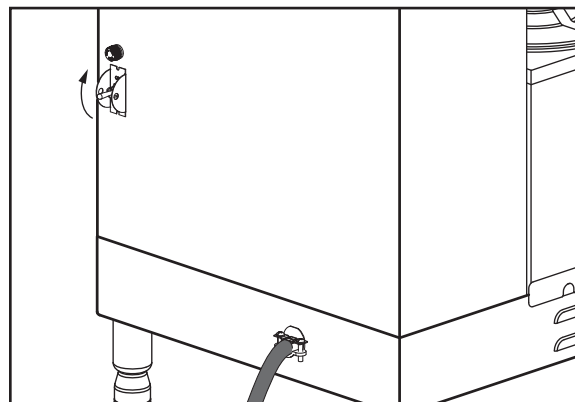

IMPORTANT: When operating the brewer at higher elevations, reduce the factory set operating temperature (200°F) by 2°F for each 1000 feet of elevation above 4000 feet. See **PROGRAMMING GUIDE**.

- 19 If the UCM is not already lit, push the ON/OFF button on the UCM. When the water level in the tank rises to the correct volume, the heating elements will turn on automatically. Depending on the incoming water temperature and the electrical specifications, the water tank typically requires 20 to 30 minutes to reach the factory set operating temperature. When the water has heated, "Ready to Brew" should be on the display.
- 20 Before brewing for the first time, dispense 12 ounces of hot water through the hot water faucet to help purge air from the tubing inside the brewer.
- 21 Brew a cycle of at least 12 ounces, to purge any remaining air from the tubing. See **OPERATING INSTRUCTIONS**. During the initial brew cycle and whenever the filter is replaced, you may hear the sounds of air being purged from the filter, tubing and water tank.

Brewing Instructions

WARNING - TO AVOID SCALDING, AVOID SPLASHING. Keep body parts clear of the brewer during brewing. Do not remove the brew basket while “Brewing” appears on the display.

NOTICE - Only use IntelliFresh satellites on IntelliFresh brewers.

The G3 Gemini Intellifresh® brewer is factory preset for optimal performance.

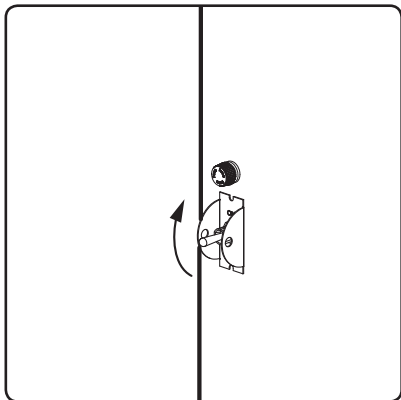

1 The brewer should be ON. Confirm this at the rear toggle switch. “Ready to brew” should be on the display. If the brewer is connected to an inter-lock grinder, the grinder should be on. When inter-lock connection is made, grind coffee at this time.

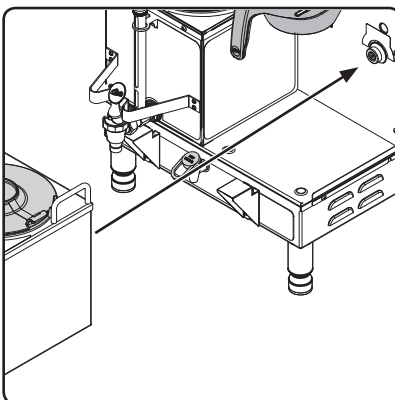

2 Place an empty IntelliFresh® satellite under the brew basket. Make sure the satellite is pushed all the way back against the front cover and is making contact with the electrical socket.

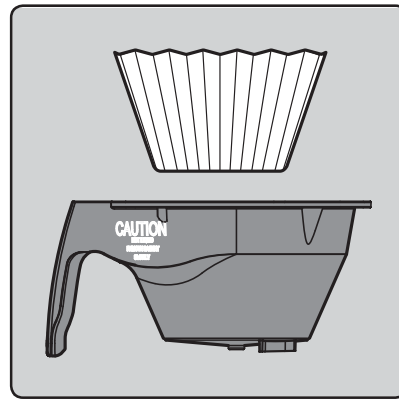

3 Insert a clean paper filter into the brew basket.

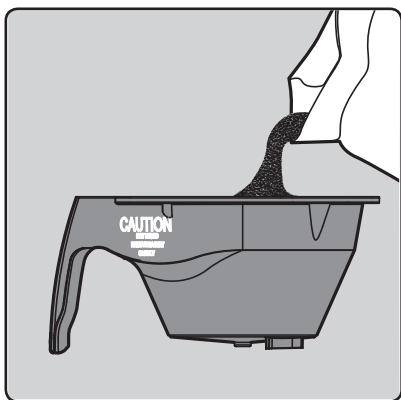

4 Fill with the proper amount of amount of ground coffee. Level the coffee in the filter.

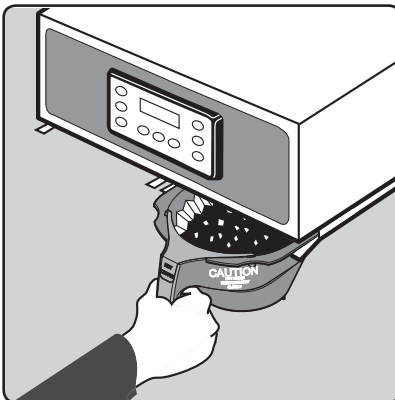

5 Slide the filled brew basket into the brew rails under the control panel. Slide it all the way back until it stops.

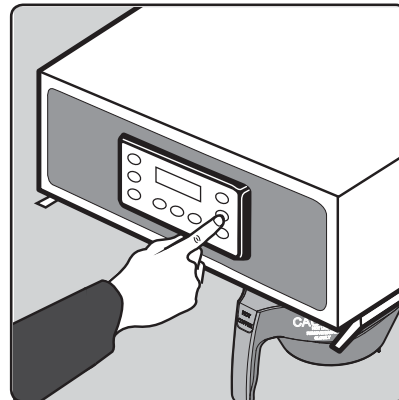

6 Press the brew button. Brewing will begin immediately and the warmer inside the satellite will turn on automatically.

The brewer will brew coffee based on the settings programmed into the universal control module (UCM). To change the settings, see the **PROGRAMMING GUIDE** section. When brewing starts, the warmer will come on. Press the warmer button to turn the warmer off without turning off the brewer.

IntelliFresh Function and Features

The IntelliFresh Quality Timer system will alert you to when the coffee has exceeded the desired freshness time. The Quality Timer is activated by a connector on the satellite connecting to a corresponding connector on the brewer. The IntelliFresh LED freshness indicator shuts off when the warmer (automatically) shuts off. Both the warmer Auto Shut-Off time and the Quality Timer are adjustable through the universal control module (UCM) on the brewer.

See the *Programming Guide* to change the Warmer Auto-Off and Quality Timer settings.

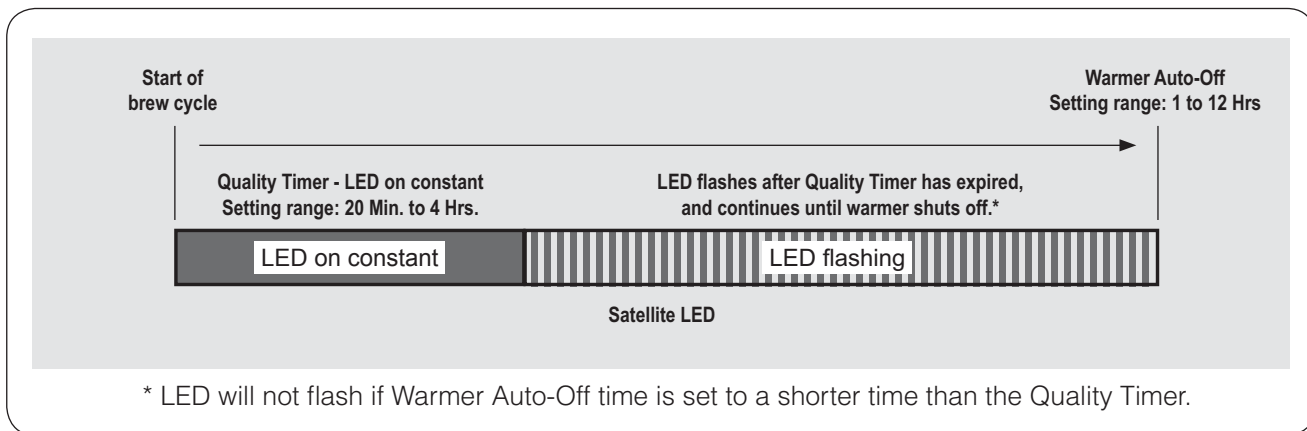

IntelliFresh LED Freshness Indicator

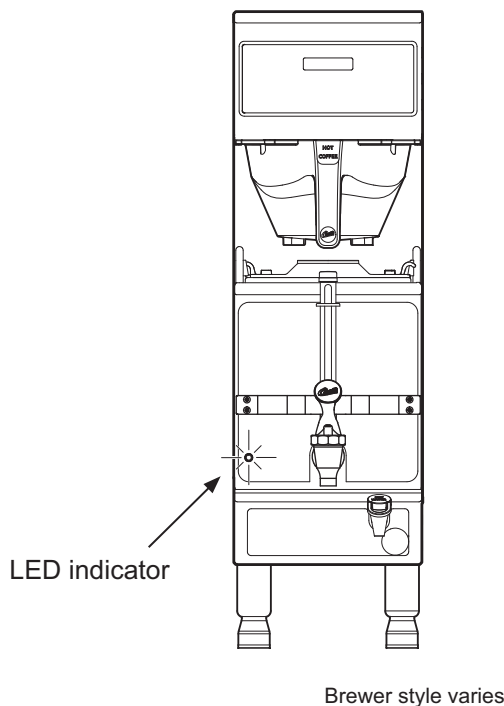



WARNING: HOT SURFACES - To avoid injury, allow the brewer and dispenser(s) to cool before cleaning.



NOTICE - Do not use cleaning liquids, compounds or powders containing chlorine (bleach) or corrosives. These products promote corrosion and will damage the finishes. **USE OF THESE PRODUCTS WILL VOID THE WARRANTY.**

Cleaning The Brewer - Daily



WARNING: DO NOT immerse the brewer in water or any other liquid.

The brewer should be OFF. Turn the brewer off by flipping the rear toggle switch to the OFF position.

- 1 Remove the dispenser(s). Wipe exterior brewer surfaces with a damp cloth to remove spills and debris.
- 2 Remove the brew basket(s) and clean them in a mild detergent solution. Use a soft bristled brush for hard to clean areas. Rinse with clean water, then dry.
- 3 Wipe the spray head area with a cloth soaked in a mild detergent solution. Rinse with a cloth soaked with clean water removing any residual detergent. Use a clean, soft cloth to dry.
- 4 Dump out the drip tray(s) (if applicable). Rinse with clean water, then dry with a soft, clean cloth.

Cleaning The Brewer - Weekly

The brewer should be OFF. Turn the brewer off by flipping the rear toggle switch to the OFF position.

- 1 Remove the spray head(s), unscrewing counterclockwise from the dome plate.
- 2 Thoroughly clean and rinse the dome plate area.
- 3 Clean the brew basket rails with a brush soaked with a mild detergent solution. Rinse the area with a cloth soaked with clean water, removing any residual detergent.
- 4 Dry the area with a soft, clean cloth.
- 5 Reattach the spray head(s).

Cleaning the Satellite (Daily)



WARNING: DO NOT immerse the satellite in water or any other liquid. Do not place the satellite in a dishwasher. Placing the satellite in a dishwasher will void the warranty.

Cleaning the Liner

- 1 Prepare a mild solution of detergent and warm water. Remove the satellite from the brewer and remove the lid. Rinse.
- 2 **Wash** - Wipe the exterior surfaces of the satellite with a sponge soaked with the detergent solution to remove spills and debris. Fill the liner with the detergent solution. Take a sponge brush and scrub out the stainless steel liner and the lid.
- 3 **Rinse** - Rinse with clean, warm water.
- 4 **Sanitize** - Sanitize the interior of the satellite and the lid, using a commercial sanitizer suitable for food grade applications. Sanitize according to the directions on the package.
- 5 **Disassemble the faucet** - Unscrew the handle/bonnet assembly from the top of the faucet and remove it. Inspect the seat cup for wear. Replace the seat cup if it is damaged.

Disassemble the sight gauge (some versions). Remove the cap and unscrew the guard, as shown, to disassemble the gauge. Remove the glass tube. Inspect it for cracks or chips. If broken, replace the glass with a new one.
- 6 **Air Dry** - Turn the satellite and lid upside down and allow to air dry.

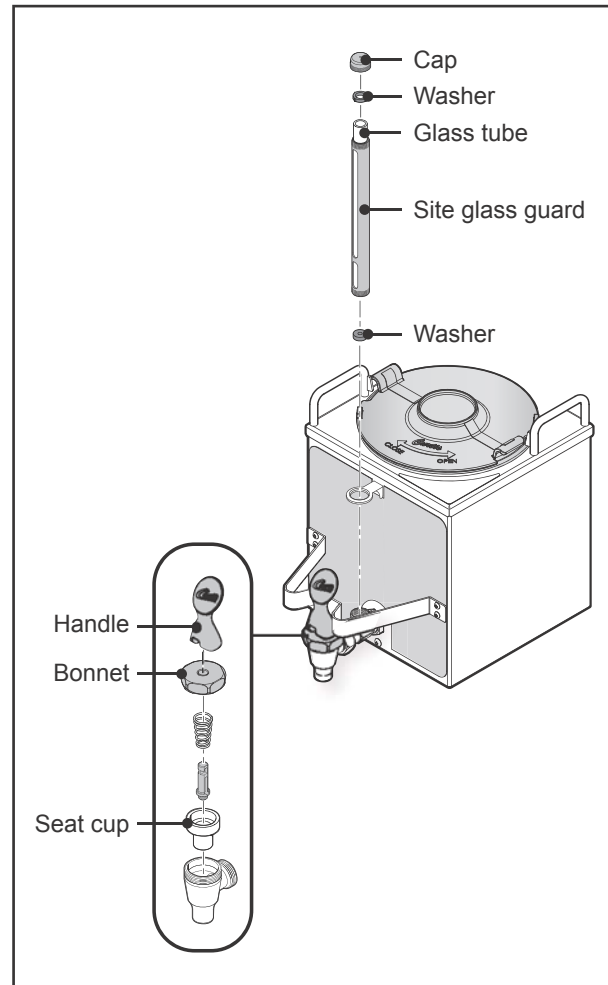

Cleaning the Faucet Parts and Site Gauge

- 7 **Wash** - Wash all faucet and gauge glass parts with the detergent solution. Clean the inside of the gauge glass with a gauge brush soaked with detergent solution.
- 8 **Rinse** - Thoroughly rinse all parts with clean, warm water.
- 9 **Sanitize** - After rinsing, place all faucet and gauge parts in a sink to be sanitized. Immerse them in a commercial sanitizer suitable for food grade applications. Sanitize according to the directions on the package.

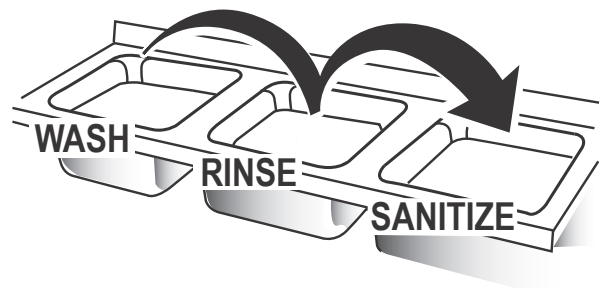

continued...

Cleaning the Faucet Parts and Site Gauge (cont.)

- 10 **Air Dry** - Allow all parts to thoroughly air dry.
- 11 **Reassemble** - When dry, reassemble the handle/bonnet. Hand tighten the handle/bonnet onto the top of the faucet assembly. Reinstall the site gauge (if applicable). If replacing a broken gauge glass, carefully remove any traces of glass from the silicone parts before inserting the new gauge glass tube. Reinstall the lid.

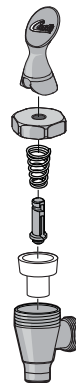

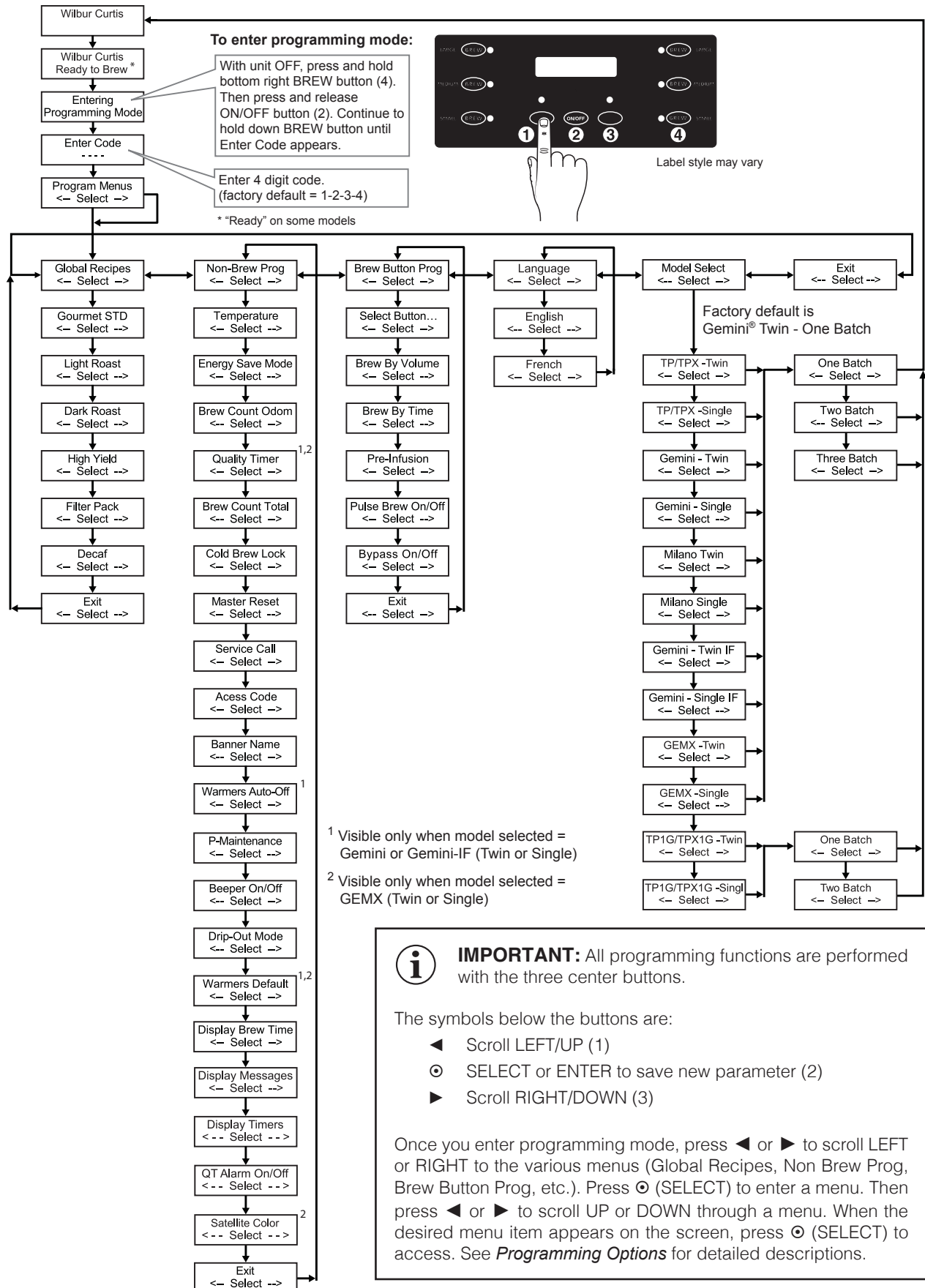

Programming Options

See the first page of the programming guide for instructions on accessing each individual menu item. Some menus save and exit automatically when a parameter is updated. Other menus exit to the previous menu when a parameter is saved. To exit, press ► until EXIT appears on the display, then press Ⓞ.

Global Recipes Menu

Select from the following coffee types: Gourmet STD (standard), Light Roast, Dark Roast, High Yield, Filter Pack or Decaf. The factory default setting is Gourmet STD. Selecting the coffee type sets the various brew settings for the brewer, shown below and on the following pages, to the factory recommended settings for the type of coffee being brewed. If desired, the individual brew settings may be changed once the coffee type is selected to meet your brewing needs.



IMPORTANT: If you change any of the brewer settings on the following pages, some or all of them may be modified if you change the coffee type afterward using the Global Recipes menu.

Non-Brew Programming Menu

Temperature - sets the brewing temperature of the water held in the water tank (the factory default is 200°F). The range is 170°F to 206°F. Once accessed, press ◀ or ▶ to choose the desired temperature. Then press Ⓞ to set and exit.

Energy Save Mode - saves energy during periods when the brewer is not in use (the factory default is OFF). When set to ON, the brewer automatically shuts off four hours (two hours on older units) after the last brew cycle. Press the ON/OFF button to return to normal operation. When set to ON 140°F, the brewer shuts off four hours (two hours on older units) after the last brew cycle. Press the ON/OFF button to return to normal operation. When set to ON 140°F, the brewer shuts off two hours after the last brew cycle, but the water tank temperature remains at 140°F. Use the ON 140°F setting to reach brewing temperature faster after periods of non-use. Once accessed, press ◀ or ▶ to choose the desired setting. Then press Ⓞ to set and exit.

Brew Count Odom - When accessed, this feature displays the total brew cycles since the odometer was last reset. Press ◀ to exit or Ⓞ reset and exit.

Quality Timer - (some models) notifies the user that the coffee is no longer fresh. See the *INTELLIFRESH® FEATURES* section for a complete description of how the timer operates. Once accessed, press ◀ or ▶ to choose the desired setting. Then press Ⓞ to set and exit.

Brew Count Total - when accessed, displays the total brew cycles on the brewer. It cannot be reset. The display returns to the previous screen automatically after a few seconds.

Cold Brew Lock - adjusts the temperature at which the brewer will brew coffee when the BREW button is pressed (**Ready to Brew** appears on the display, the factory default is 5°F). This feature also adjusts the temperature at which the heating element turns on to reheat the water in the tank. The available settings are 5°F, 15°F and OFF. OFF is within 30°F below the temperature setting. Once accessed, press ◀ or ▶ to choose the desired setting. Then press Ⓞ to set and exit.

Master Reset - resets the brewer universal control module (UCM) to the factory default settings. Once accessed, "Are You Sure?" will appear on the display. Press ◀ for Yes or ▶ for No.



IMPORTANT: If you reset the UCM to the factory defaults, you **MUST** reprogram the *Model Select* and number of batches to match the number on the model number label and the label on the UCM for proper operation.

Programming Options (cont.)

Service Call - sets the service phone number that appears on the display when the UCM detects a SENSOR ERROR or WATER ERROR . Once accessed, press ◀ or ▶ to choose the number to be changed. Then press Ⓞ repeatedly to change the number value. Press ◀ or ▶ to choose the next number to change or choose exit and press Ⓞ.

Access Code - sets the access code entered to access programming mode (the factory default is 1-2-3-4). Once accessed, press ◀ or ▶ to choose the number to change. Then press Ⓞ repeatedly to change the number value (range is 1 to 4). Press ◀ or ▶ to choose the next number to change or choose exit and press Ⓞ.

Banner Name - changes the banner name that appears on the display (the factory default is **Curtis**). No banner name appears when all blanks are entered. Once accessed, press ◀ or ▶ to choose the letter to change. Then press Ⓞ repeatedly to change the number value. Press ◀ or ▶ to choose the next number to change or choose ex and press Ⓞ to exit.

Warmer Auto-Off - (some models) adjusts the length of time that elapses before the satellite warmer shuts off automatically. This function takes priority over the quality timer (factory default for GEMIF is 10 hours, Gemini default is "disabled"). The range is 1 to 12 hours. Once accessed, press ◀ or ▶ to adjust the number of hours. Then press Ⓞ to set and exit.

P-Maintenance - turns on/off and adjusts the P-Maintenance (preventive maintenance) brew monitor (the factory default is OFF). When ON, the UCM measures the number of gallons brewed before the P-Maintenance reminder appears on the display. The range is OFF to 9500 gallons. Once accessed, press ◀ or ▶ to choose the desired setting, then, press Ⓞ to exit.

Beeper On/Off - turns the beeper that is heard each time a button is pressed on or off (the factory default is ON). Once accessed, press ◀ or ▶ to choose the desired setting. Then, press Ⓞ to exit.

Drip-out Mode - sets the drip-out mode timer. After water stops flowing, it allows additional time for the water to drain from the brew basket before the brew basket lock releases (the factory default is 2 min.). This feature reduces the chance that the brew basket will be removed too early. The range is OFF to 5 minutes. Once accessed, press ◀ or ▶ to choose desired setting, then, press Ⓞ to exit.

Warmers Default - (some models) sets the warmer temperature (the factory default is MED). The available settings are OFF*, HIGH (188°F), MED (185°F) or LOW (182°F)**. The temperature settings are ±3°F. Once accessed, press ◀ or ▶ to choose the desired setting, then press Ⓞ. On twin brewers press ◀ or ▶ to choose the desired setting for the second warmer, then press Ⓞ. Press Ⓞ to exit. *OFF option not available on GEMX series models. **GEMIF and GEMX only - temperatures based on a brew temperature of 200°F.

Display Brew Time - turns the display of the brew time during brewing on or off (the factory default is ON). Once accessed, press ◀ or ▶ to choose the desired setting, then press Ⓞ to exit.

Display Messages - turns display of the message "Rinse Server Before Brewing" ON or OFF (the factory default is ON). Once accessed, press ◀ or ▶ to choose the desired setting, then press Ⓞ to exit.

[QT] Display Timers [On/Off] - (some models, QT Alarm must be on) turns the quality timer countdown display ON or OFF (the factory default is OFF). Once accessed, press ◀ or ▶ to choose the desired setting. Then, press Ⓞ to exit.

QT Alarm On/Off - (some models) turns the quality timer alarm ON or OFF (the factory default is ON for Gemini models, OFF for GEMIF and GEMX). An audible alarm goes off when the quality timer has expired. Once accessed, press ◀ or ▶ to choose the desired setting. Then, press Ⓞ to exit.

Programming Options (cont.)

Satellite Color - (GEMX series models only) changes the color scheme of the quality timer LEDs. Once accessed, press ◀ or ▶ to choose the desired color to indicate “fresh” (ON). Press Ⓞ to save, then press ◀ or ▶ to choose the desired color to indicate “expired”. Press Ⓞ to save and exit.

Brew Button Programming Menu

When you first enter the Brew Button Programming menu, you will be asked to select (press) a BREW button to change the settings for. To program more than one BREW button, finish programming the first, then press ▶ until Exit appears on the display. Press Ⓞ to exit, then re-enter the Brew Button Program to program the next one.

Brew by Volume - adjusts the volume brewed (the factory defaults are LARGE 200oz ±8oz., MEDIUM 132oz±4oz., SMALL 64oz±4oz). With a satellite in place, press the BREW button that is illuminated. When the desired volume is reached, press the same BREW button again to stop the brew cycle and set the volume.

Brew by Time - adjusts the amount of coffee brewed by time rather than by volume (the factory defaults are LARGE 5min-25sec., MEDIUM 3min-32sec., SMALL 1min-52sec). Once accessed, press ◀ or ▶ until the number of minutes is flashing. Then press Ⓞ repeatedly to change the number value. Press ◀ or ▶ until the number of seconds is flashing. Then press Ⓞ repeatedly to change the number value. Press ◀ or ▶ until “ex” is flashing, then, press Ⓞ to exit.

Pre-Infusion - sets the brewer Pre-Infusion time (Pulse Brew must be off to access, the factory default is Disabled). Pre-Infusion increases control of coffee clarity and extraction. When turned on, the range is 10 to 60 seconds. Once accessed, press ◀ or ▶ to choose the desired setting, then, press Ⓞ to exit. To turn off pulse brew mode, choose 0 for the time.

When Pre-infusion is ON, Pulse Brew disappears from the list of menu items.

Pulse Brew - selects the pulse brew pattern (Pre-Infusion must be off to access, the factory default is C). The pulse brew pattern selected “tunes” or changes the flavor of the coffee. Once accessed, press ◀ or ▶ to choose the desired setting. Then, press Ⓞ to exit.

 When Pulse Brew is on, Cold Brew Lock is set within 5°F and, Cold Brew Lock and Pre-Infusion disappear from the list of program selections.

Setting	Description
A	Toward the beginning of brew cycle: 4 cycles of 10 seconds on and 10 seconds off, then on until end of brew cycle.
B	Starts towards ends of brew cycle. 4 cycles of 10 seconds off and 4 cycles of 10 seconds on. Ends when brew cycle ends.
C	Starts at beginning of brew cycle. 5 cycles of 25 seconds on and 20 seconds off, then on until end of brew cycle.
D	Manually set. Starts at beginning of brew cycle. Number of pulses is adjustable from 1 to 20. Pulse on time and off time are both adjustable from 5 to 150 seconds.
E	Manually set. Starts at beginning of brew cycle. Number of pulses is adjustable from 1 to 8. Pulse on time and off time are both adjustable from 1 to 150 seconds.

Pulse Brew Guidelines

- Filter pack type coffees typically extract better with the A and B pulse setting.
- Decaffeinated coffees typically extract better with the B pulse setting.
- High-yield coffees typically extract better with the C pulse setting. Of course, any of the A, B or C settings may be used to suit your taste profile.
- Settings D and E are manual pulse counts.

Programming Options (cont.)

By-Pass - helps control extraction with larger brews (the factory defaults are LARGE 35%, MEDIUM 10%, SMALL Off). It reduces contact time to avoid extraction of undesirable bitter and harsh flavor compounds. The range is OFF to 50%. Once accessed, press ◀ or ▶ to choose the desired setting, then, press Ⓞ to exit.

Language - changes the language that appears on the display (the factory default is English). This feature is programmable for changing and adding languages. Once accessed, press ◀ or ▶ to choose the desired setting, then press Ⓞ to exit.

Model Select - changes the model number and number of batches (to match the label on the universal control module, the factory default is Gemini-Twin IF, single batch). Once accessed, press ◀ or ▶ until the model number matching the model number label on the brewer appears, then press Ⓞ. Press ◀ or ▶ until the number of batches matches the number of batch sizes on the UCM label, then press Ⓞ to exit.

GEMTIF - Twin Coffee Brewer

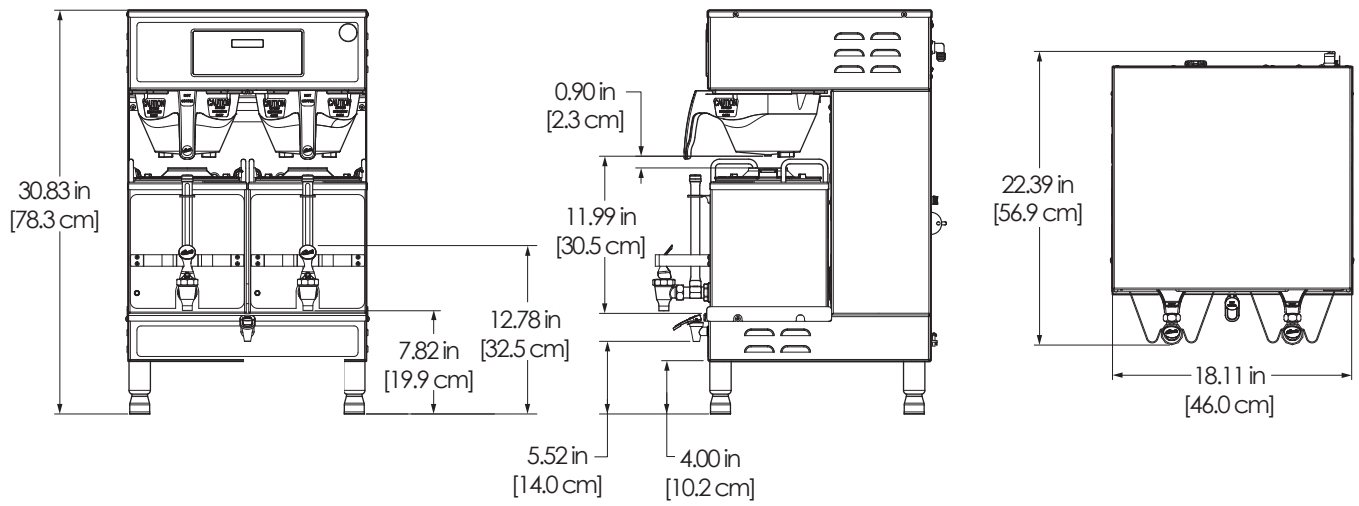

GEMSIF - Single Coffee Brewer

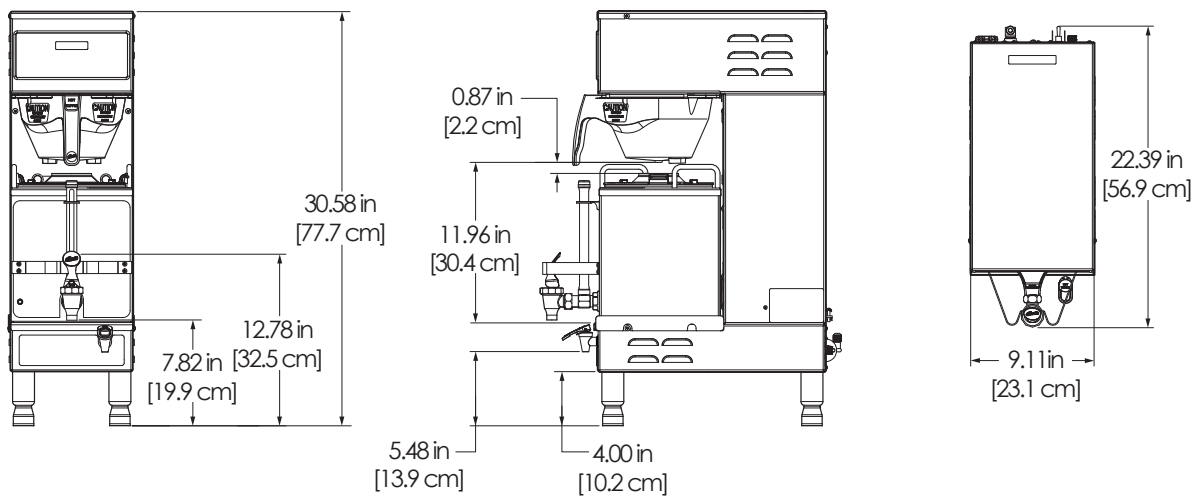

GEM3IF - Satellite Server

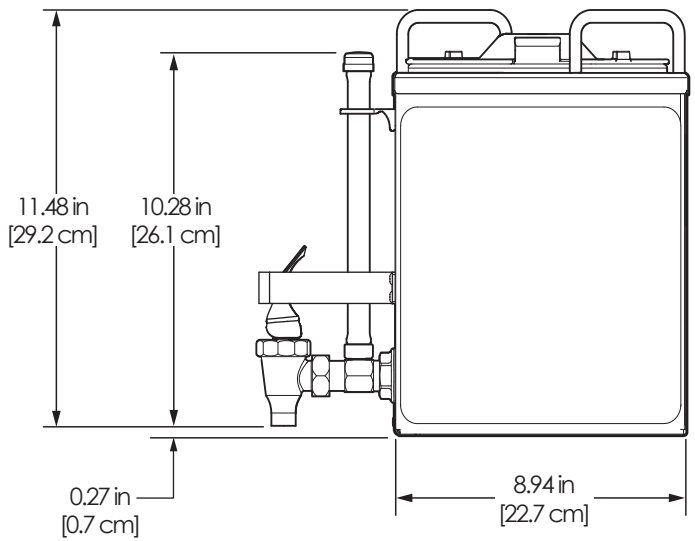
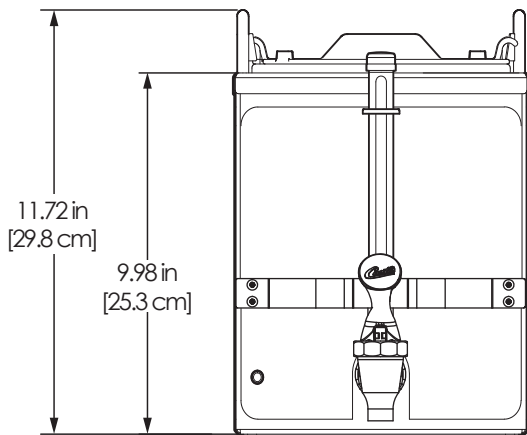
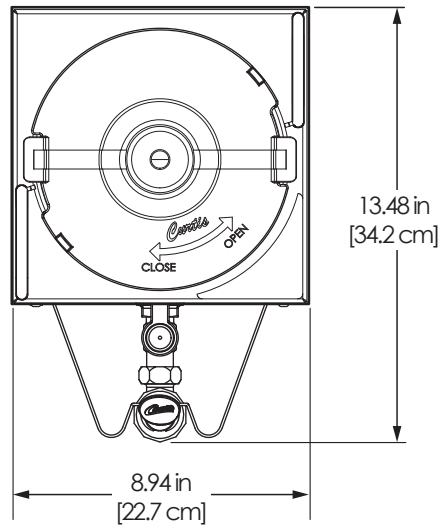

GEMTIF - Main Chassis - Exploded View

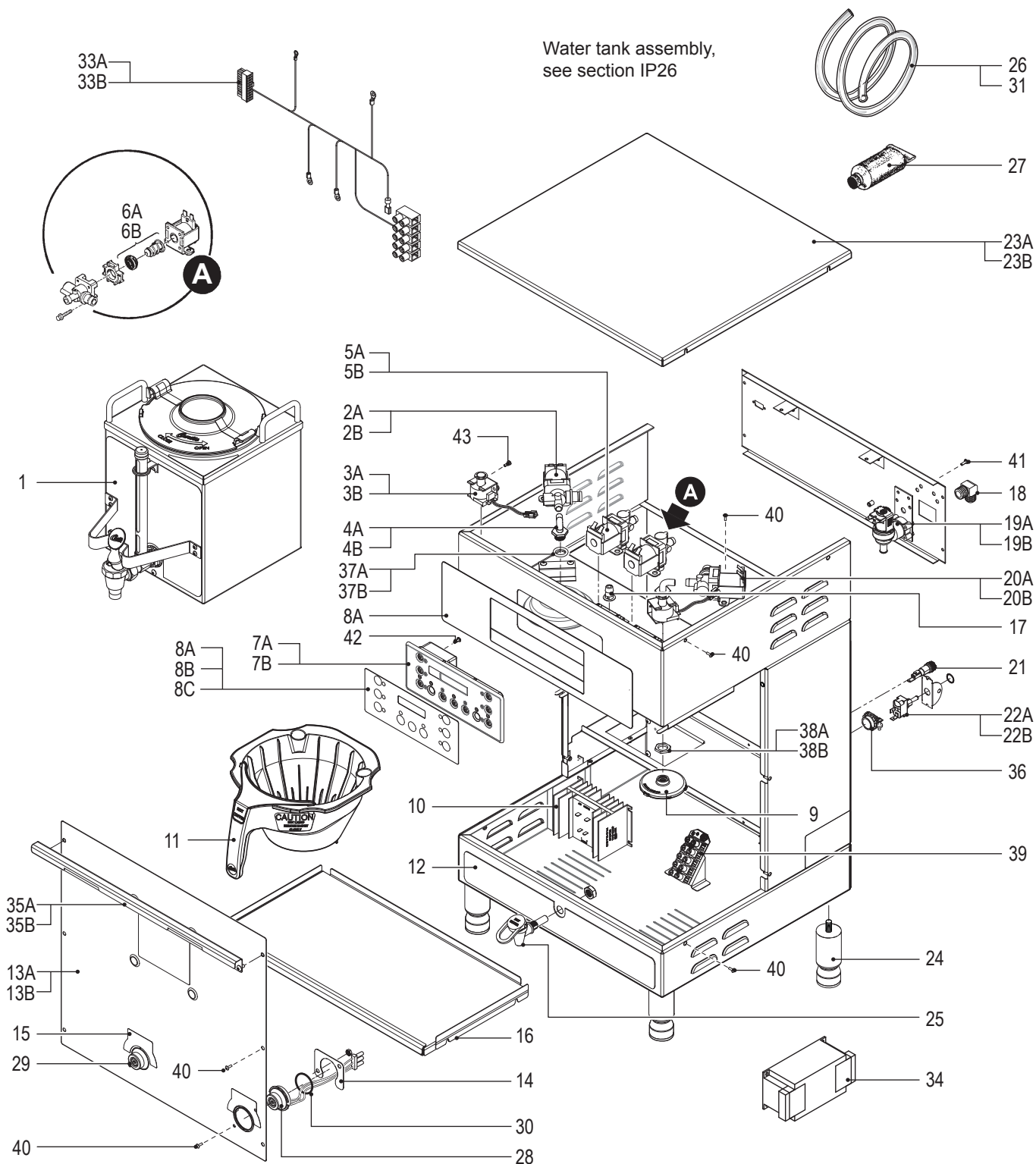

Water tank assembly, see section IP26

GEMTIF - Main Chassis - Parts List

ITEM #	PART #	DESCRIPTION
1	GEM3IF	SATELLITE SERVER, 1-1/2 GAL. 75W 120V .60A W/INTELLIFRESH
2A*	WC-821WDR ^{1,2}	VALVE, DUMP LEFT 120V 12W W/INTERNAL RESISTOR & DIODE
2B	WC-853 ³	VALVE, BREW DUMP LEFT 240V 12W GEM12D/TP/TPC
3A	WC-442 ^{1,2}	SOLENOID, LOCK BREW CONE RIGHT/LEFT 120V TP2T/TP2S/GEMSS/GEM
3B	WC-446 ³	SOLENOID, LOCK BREW CONE RIGHT 220V THERMOPRO/GEMTS
4A*	WC-2977K ^a	KIT, SPRAYHEAD FITTING METAL
4B	WC-2977-101K ^b	KIT, SPRAYHEAD FITTING PLASTIC
5A*	WC-844-101 ^{1,2}	VALVE, BY-PASS, NON-ADJUSTABLE WITH RESTRICTOR (WC-2945)
5B	WC-844-102 ³	VALVE, BY-PASS, 220V NON-ADJUSTABLE W/ RESTRICTOR (WC-2945)
6A	WC-37132	KIT, VALVE REPAIR FOR INVENSYS WC-820WDR, WC-821WDR, WC-844WDR (OLDER UNITS)
6B	WC-37132-101	KIT, VALVE REPAIR FOR DELTROL WC-820WDR, WC-821WDR, WC-844WDR (NEWER UNITS)
7A	WC-723 ^{1,2}	CONTROL MODULE, UCM 120V TP2S /TP2T GEMSS/GEMTS
7B	WC-728 ³	CONTROL MODULE, UCM 220V TP2S/ TP2T/ GEMSS/GEMTS
8A*	WC-39744	LABEL, UCM OVERLAY DUAL TWIN 3-BATCH GEMTIF
8B*	WC-39756	LABEL, UCM OVERLAY PANEL 2-BATCH GEMTIF CURTIS
8C*	WC-39755	LABEL, UCM OVERLAY PANEL 1-BATCH GEMTIF CURTIS
9*	WC-29050	SPRAYHEAD, AMBER ADVANCED FLOW
10*	WC-8559	RELAY, SOLID STATE 280V/40A W/ HEATSINK AND QUICK DISCONNECTS
11*	WC-3417	BREW CONE, ASSY W/SPLASH POCKET BRWN STYLIZED GEMIN HOT COFFEE
12	WC-39745	LABEL, BOTTOM PANEL GEMTIF
13A	WC-61959 ^{1,3}	COVER, FRONT GEMTIFSS
13B	WC-61959-BLK ²	COVER, FRONT GEMTIFBLK
14	WC-61963	PLATE, HOLDER IF CONNECTORS GEMTIF
15	WC-38504	LABEL, WARNING SHOCK HAZARD INTELLI-FRESH
16	WC-61961	DECK, WARMER GEMTIFSS NEW
17	WC-29044-101	SLEEVE, OVERFLOW
18*	WC-2402P-P	ELBOW, 3/8"FL x 3/8" NPT PLATED
19A*	WC-847 ^{1,2}	VALVE, INLET 2 GPM 120V 10W GEN USE BROWN BODY
19B	WC-883 ³	VALVE, INLET 2 GPM 240V 6W

¹ GEMTIF10A1000, ² GEMTIF10B1000, ³ GEMTIF30A1000

^a Units built 05/15/17 and later. Stainless steel fitting kit (4A) is compatible with older units.

^b Units built before 05/15/17.

* Recommended parts to stock

ITEM #	PART #	DESCRIPTION
20A*	WC-820WDR ^{1,2}	VALVE, DUMP RIGHT 120V 12W W/INTERNAL RESISTOR & DIODE
20B	WC-854 ³	VALVE, BREW DUMP RIGHT 240V 12W GEM12D/TP/TPC
21*	WC-1501	FUSE, HOLDER ASSY W/5A FUSE
22A*	WC-102 ^{1,2}	SWITCH, TOGGLE NON-LIT SPST 15A 125/6A 250VAC RESISTIVE
22B	WC-103 ³	SWITCH, TOGGLE NON-LIT DPST 25A 125/250VAC RESISTIVE
23A	WC-61955 ^{1,3}	COVER, TOP SSTL GEMTIF
23B	WC-61955-BLK ²	COVER, TOP GEMTIF BLK
24*	WC-3528	LEG, 4" ADJUSTABLE 3/8-16 THRD ITALIAN STYLE
25*	WC-1809	FAUCET, PS/HPS SERIES HOT WTR 1/2-20 UNF AP/ALP
26*	WC-5310	TUBE, 5/16 ID x 1/8W SILICONE GEN USE
27*	WC-5231	COMPOUND, HEAT SINK 5OZ
28	WC-571K-R	KIT, IF CONNECTOR- RIGHT
29	WC-571K-L	KIT, IF CONNECTOR- LEFT
30	WC-43133	O-RING, 1.424ID X 1.630 OD X .103 WALL GEMIF's
31*	WC-5350	TUBE, 1/2 ID x 1/8W SILICONE GEN USE
32	WC-1250 ³	CORD, 4mm ² 90°C 49A 450/750V 6 FT LG W/ FERRULES ONE END (NOT SHOWN)
33A	WC-13335 ^{1,2}	HARNESS ASSY, COMPLETE TP2T10/ GEMTS FOR SOLID STATE RELAY (INCLUDES TERMINAL BLOCK)
33B	WC-13338 ³	HARNESS ASSY, COMPLETE TP2T30 GEMTS FOR SOLID STATE RELAY (INCLUDES TERMINAL BLOCK)
34	WC-596K ³	KIT, NOISE FILTER EMI 250V/30A 1PH
35A	WC-61954 ^{1,3}	PLATE, BREW CONE STOP SSTL GEMTIF
35B	WC-61954-BLK ²	PLATE, BREW CONE STOP GEMTIF BLK
36	WC-1412	CORD GRIP, 3/4" FOR METAL CORD TO .81"OD
37A	WC-4320 ^a	O'RING, 0.4871.D.x 0.693OD x0.103CS BUNA-N #112
37B	WC-43089 ^b	GASKET, 1.00OD X .625 I.D. X .030 THK WHITE EPDM 70 SHORE
38A	WC-4213-P ^a	NUT, 5/8 LOCK PLATED
38B	WC-4212-02 ^b	NUT, 5/8-18 JAM PLASTIC
39	WC-314	POWER BLOCK, 5 STATION
40	WC-4426	SCREW, 8-32x3/8 PH HEAD TRUSS
41	WC-4616	SCREW, 1/4-20 x 1/2 PHILLIPS PAN HEAD STAINLESS STEEL
42	WC-4439	SCREW, 6-32x1/4 PHIL PAN HD SS
43	WC-4412	SCREW, 10-32x3/16" PH PN HD MS SS

Supplies and Accessories - All Models



WC-29050 - Spray Head



CAB-1 - Cleaning Brush

Sold individually or by the case

GEMSIF - Main Chassis - Exploded View

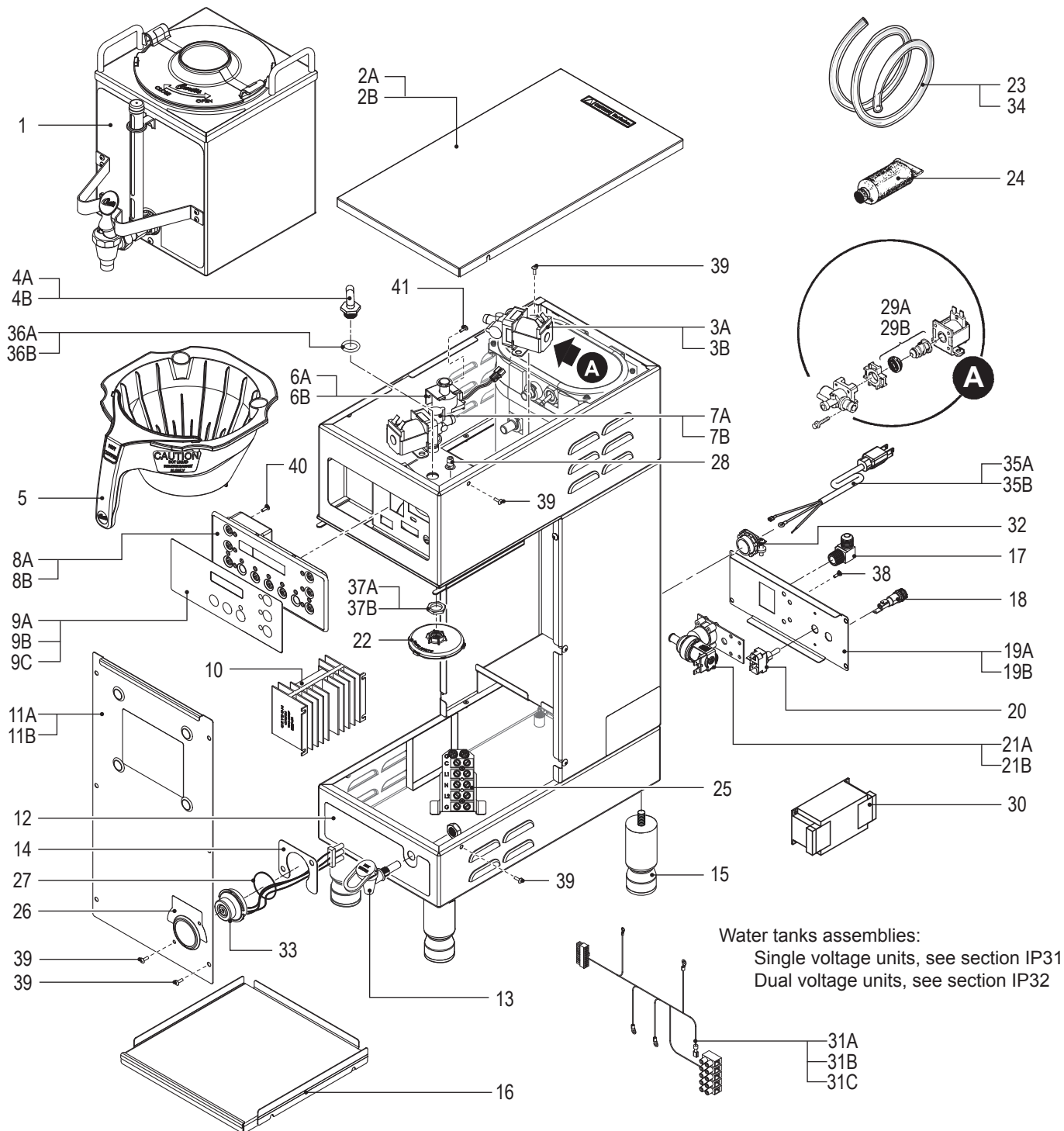

GEMSIF - Main Chassis - Parts List

ITEM #	PART #	DESCRIPTION
1	GEM3IF	SATELLITE SERVER, 1-1/2 GAL. 75W 120V .60A W/INTELLIFRESH
2A	WC-61928 ^{1,2,4}	COVER, TOP ALPGT/D500GT/D60GT/TLP/TCTS/CBS/GEMSS
2B	WC-61928-BLK ³	COVER, TOP GEMSIF63B1000
3A*	WC-820WDR ^{1,2,3}	VALVE, DUMP RIGHT 120V 12W W/INTERNAL RESISTOR & DIODE
3B	WC-854 ⁴	VALVE, BREW DUMP RIGHT 240V 12W GEM12D/TP/TPC
4A*	WC-2977K ^a	KIT, SPRAYHEAD FITTING METAL
4B	WC-2977-101K ^b	KIT, SPRAYHEAD FITTING PLASTIC
5	WC-3417	BREW CONE, ASSY W/SPLASH POCKET BRWN STYLIZED GEMIN HOT COFFEE
6A	WC-442 ^{1,2,3}	SOLENOID, LOCK BREW CONE RIGHT/LEFT 120V TP2T/TP2S/GEMSS/GEM
6B	WC-446 ⁴	SOLENOID, LOCK BREW CONE RIGHT 220V THERMOPRO/GEMTS
7A*	WC-844-101 ^{1,2,3}	VALVE, BY-PASS, NON-ADJUSTABLE WITH RESTRICTOR (WC-2945)
7B	WC-844-102 ⁴	VALVE, BY-PASS, 220V NON-ADJUSTABLE W/ RESTRICTOR (WC-2945)
8A	WC-723 ^{1,2,3}	CONTROL MODULE, UCM 120V TP2S /TP2T GEMSS/GEMTS
8B	WC-728 ⁴	CONTROL MODULE, UCM 220V TP2S/ TP2T/ GEMSS/GEMTS
9A*	WC-39801	LABEL, UCM PANEL 3-BATCH GEMSIF INTELLIFRESH CURTIS
9B*	WC-39802	LABEL, UCM PANEL 2-BATCH GEMSIF INTELLIFRESH CURTIS
9C*	WC-39803	LABEL, UCM PANEL 1-BATCH GEMSIF INTELLIFRESH CURTIS
10*	WC-8559	RELAY, SOLID STATE 280V/40A W/ HEATSINK AND QUICK DISCONNECTS
11A	WC-61927 ^{1,2,4}	COVER, FRONT GEMSIF10/63/30
11B	WC-61927-BLK ³	COVER, FRONT GEMSIF63B1000
12	WC-39800	LABEL, BOTTOM WRAP GEMSIF INTELLIFRESH CURTIS
13*	WC-1809	FAUCET, PS/HPS SERIES HOT WTR 1/2-20 UNF AP/ALP
14	WC-61963	PLATE, HOLDER IF CONNECTORS GEMTIF
15*	WC-3528	LEG, 4" ADJUSTABLE 3/8-16 THRD ITALIAN STYLE
16	WC-61930	DECK, WARMER W/A GEMSIF63B1000
17*	WC-2402P-P	ELBOW, 3/8"FL x 3/8" NPT PLATED
18	WC-1501	FUSE, HOLDER ASSY W/5A FUSE
19A	WC-59020 ^{1,2,4}	PANEL, BOTTOM BACK REMOVABLE
19B	WC-59020-BLK ³	PANEL, BACK REMOVABLE GEMSS BLACK TEXTURE

¹ GEMSIF10A1000, ² GEMSIF63A1000, ³ GEMSIF10B1000, ⁴ GEMSIF30A1000

^a Units built 05/15/17 and later. Stainless steel fitting kit (4A) is compatible with older units.

^b Units built before 05/15/17.

* Recommended parts to stock

ITEM #	PART #	DESCRIPTION
20*	WC-103	SWITCH, TOGGLE NON-LIT DPST 25A 125/250VAC RESISTIVE
21A*	WC-847 ^{1,2,3}	VALVE, INLET 2 GPM 120V 10W GEN USE BROWN BODY
21B	WC-883 ⁴	VALVE, INLET 2 GPM 240V 6W
22*	WC-29050	SPRAYHEAD, AMBER ADVANCED FLOW
23*	WC-5310	TUBE, 5/16 ID x 1/8W SILICONE
24*	WC-5231	COMPOUND, HEAT SINK 5OZ
25*	WC-314	POWER BLOCK, 5 STATION
26	WC-38504	LABEL, WARNING SHOCK HAZARD INTELLIFRESH
27	WC-43133	O-RING, 1.424ID X 1.630 OD X .103 WALL GEMIF's
28	WC-29044-101	SLEEVE, OVERFLOW
29A*	WC-37132	KIT, VALVE REPAIR FOR INVENSYS WC-820WDR, WC-821WDR, WC-844WDR (OLDER UNITS)
29B	WC-37132-101	KIT, VALVE REPAIR FOR DELTROL WC-820WDR, WC-821WDR, WC-844WDR (NEWER UNITS)
30	WC-596K ⁴	KIT, NOISE FILTER EMI 250V/30A 1PH
31A	WC-13287 ^{1,2,3}	HARNESS, ASSY COMPLETE GEMSS (INCLUDES TERMINAL BLOCK)
31B	WC-13298 ²	HARNESS ASSY, DV CONVERSION GEMSS/TP2S
31C	WC-13379 ⁴	HARNESS, ASSY COMPLETE GEMSS EXPORT GEMSS30 (INCLUDES TERMINAL BLOCK)
32	WC-1412	CORD GRIP, 3/4" FOR METAL CORD TO .81"OD
33	WC-571K-R	KIT, IF CONNECTOR- RIGHT
34	WC-5350	TUBE, 1/2 ID x 1/8W SILICONE GEN USE
35A	WC-1200 ²	CORD, 14/3 SJTO 6' BLK W/PLUG
35B	WC-1250 ⁴	CORD, 4mm ² 90°C 49A 450/750V 6 FT LG W/ FERRULES ONE END
36A	WC-4320 ^a	O'RING, 0.4871.D.x 0.693OD x0.103CS BUNA-N #112
36B	WC-43089 ^b	GASKET, 1.000D X .625 I.D. X .030 THK WHITE EPDM 70 SHORE
37A	WC-4213-P ^a	NUT, 5/8 LOCK PLATED
37B	WC-4212-02 ^b	NUT, 5/8-18 JAM PLASTIC
38	WC-4426	SCREW, 8-32x3/8 PH HEAD TRUSS
39	WC-4616	SCREW, 1/4-20 x 1/2 PHILLIPS PAN HEAD STAINLESS STEEL
40	WC-4439	SCREW, 6-32x1/4 PHIL PAN HD SS
41	WC-4412	SCREW, 10-32x3/16" PH PN HD MS SS

WC-62033 - Tank Assembly

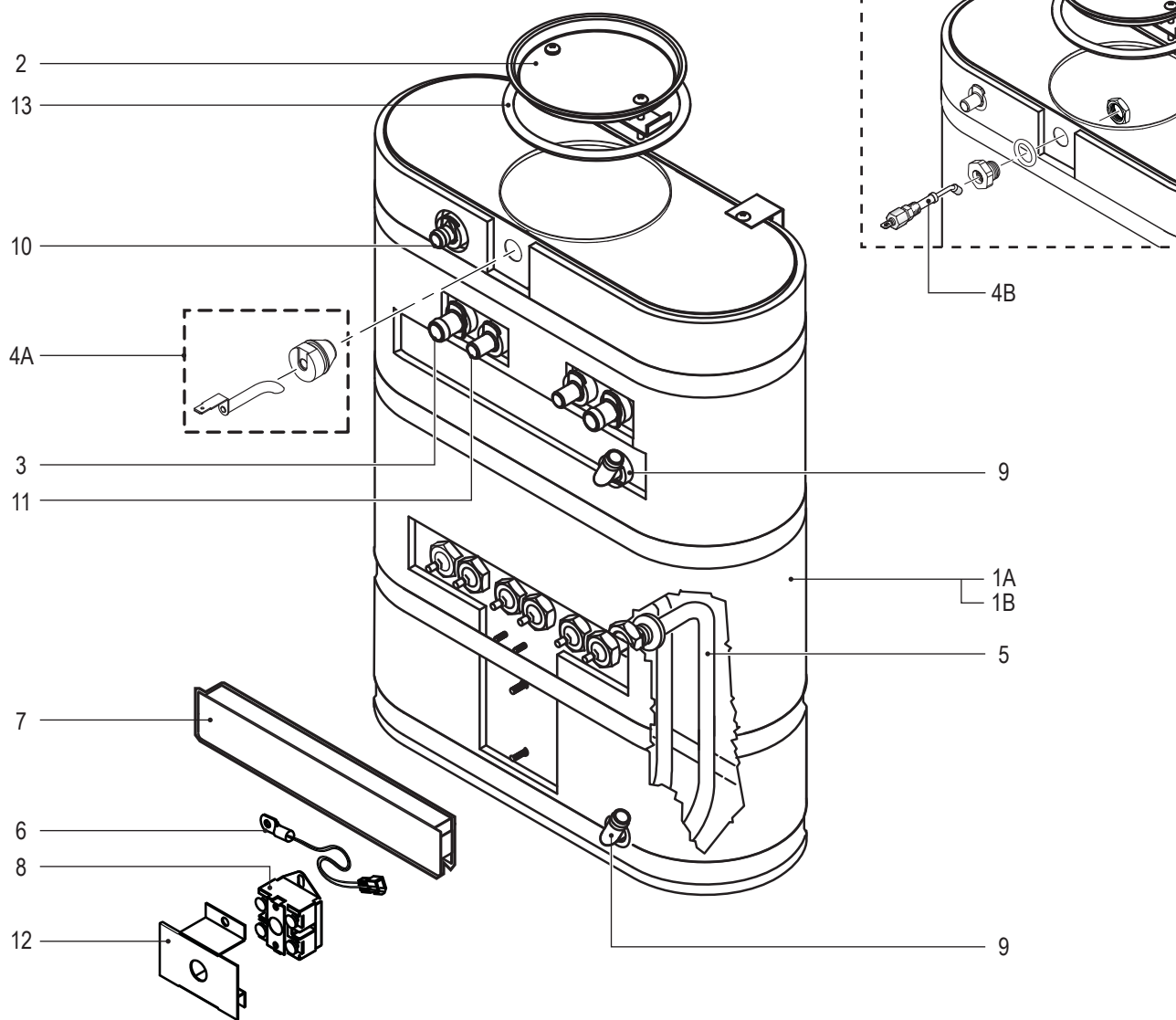

WC-62033 - Tank Assembly - Parts List

ITEM #	PART #	DESCRIPTION
1A	WC-54287	TANK, ASSY TPS1T/GEMTS
1B	WC-62033	TANK, COMPLETE GEMTS W/ULTEM FITTINGS
2	WC-37008	KIT, TANK LID ROUND (INCLUDES GASKET)
3*	WC-37357	KIT, STRAIGHT PLASTIC FITTING AND BUSHING 12MM
4A ¹	WC-5528K	KIT, WATER LEVEL PROBE, SILICONE
4B ²	WC-5502-01	KIT, PROBE, ASSY WATER LEVEL W/HEX FITTING, O-RING & NUT
5*	WC-934-04	KIT,ELEMENT HEATING 2.5KW 220V W/ JAM NUT & SILICONE WASHERS
6*	WC-1438-101	SENSOR, TEMPERATURE TANK

ITEM #	PART #	DESCRIPTION
7*	WC-4382	GUARD, SHOCK HTNG ELMNT DOUBLE
8*	WC-522	THERMOSTAT, HI LIMIT HEATER CONTROL DPST 277V 40A
9*	WC-37365	KIT, FITTING TANK INLET
10*	WC-37266	KIT, FITTING TANK OVERFLOW
11*	WC-37317	KIT, STRAIGHT FITTING & BUSHNG 8MM GEN USE
12*	WC-43055	GUARD, SHOCK RESET THERMOSTAT (WC-522)
13*	WC-43067	SILICONE TANK LID O-RING, 4-1/2" I.D. X Ø.285

¹ Units built 01/04/2019 and later.

² Units built before 01/04/2019. Replaces WC-5527.

* Recommended parts to stock.

WC-62035 - Tank Assembly

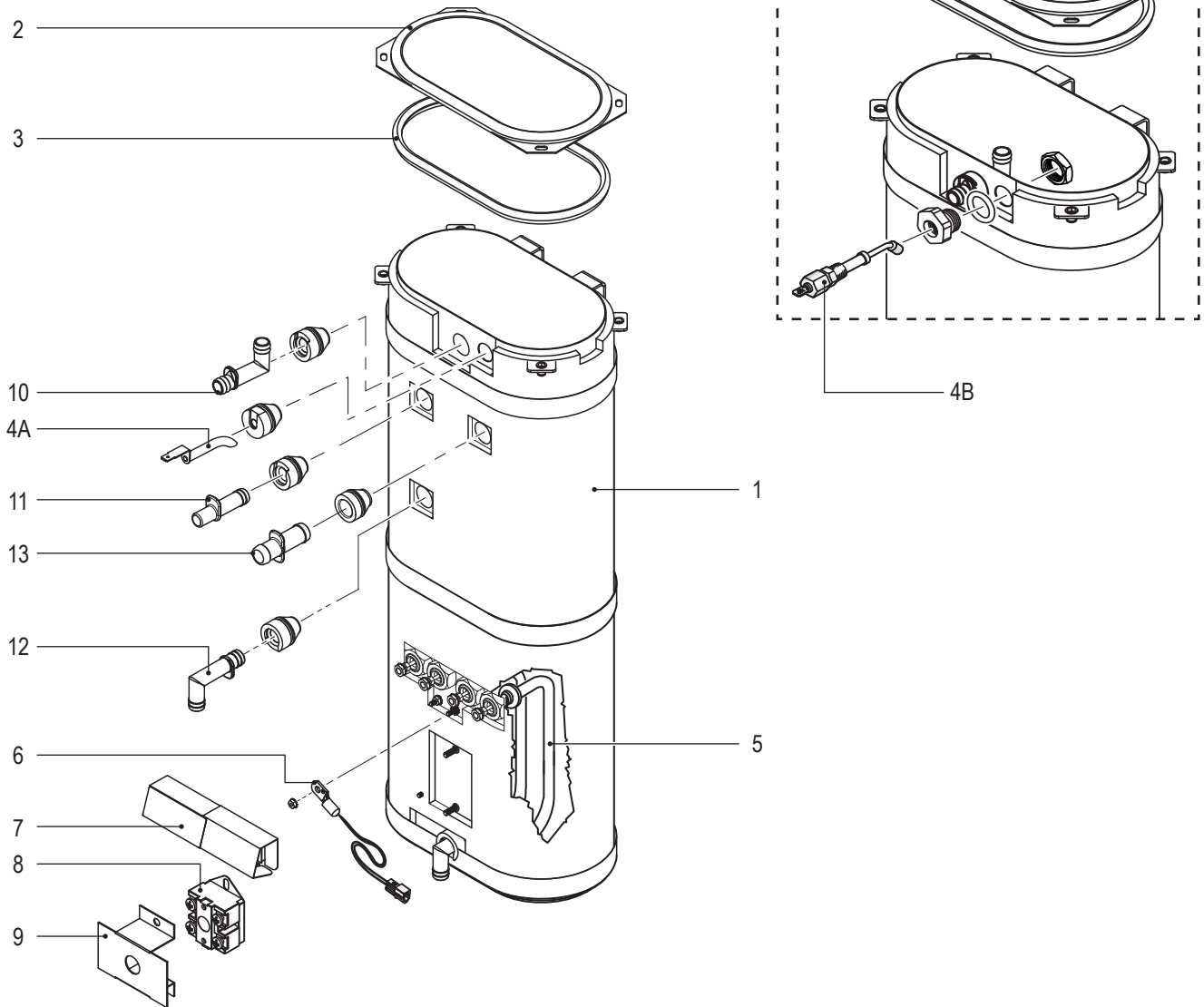

WC-62035 - Tank Assembly - Parts List

ITEM #	PART #	DESCRIPTION
1	WC-62035	TANK, COMPLETE GEMSS W/ULTEM FITTINGS
2	WC-5853-102	COVER, TOP HEATING TANK GEN USE
3*	WC-43062	GASKET, TANK LID
4A ¹	WC-5528K	KIT, WATER LEVEL PROBE, SILICONE
4B ²	WC-5502-01	KIT, PROBE, ASSY WATER LEVEL W/HEX FITTING, O-RING & NUT
5*	WC-906-04	KIT, ELEMENT, HEATING 2KW 220V W/ JAM NUT & SILICONE O-RING
6*	WC-1438-101	SENSOR, TEMPERATURE TANK
7*	WC-4394	GUARD, SHOCK/HEATING ELEMENT FOR SINGLE HEATING ELEMENT

ITEM #	PART #	DESCRIPTION
8*	WC-522	THERMOSTAT, HI LIMIT HEATER CONTROL DPST 277V 40A
9*	WC-43055	GUARD, SHOCK RESET THERMOSTAT (WC-522)
10*	WC-37266	KIT, FITTING TANK OVERFLOW
11*	WC-37317	KIT, STRAIGHT FITTING & BUSHING 8mm GEN USE
12*	WC-37365	KIT, FITTING TANK INLET
13*	WC-37357	KIT, STRAIGHT PLASTIC FITTING AND BUSHING 12MM

¹ Units built 01/04/2019 and later.

² Units built before 01/04/2019. Replaces WC-5527.

• Recommended parts to stock.

WC-62034 - Tank Assembly

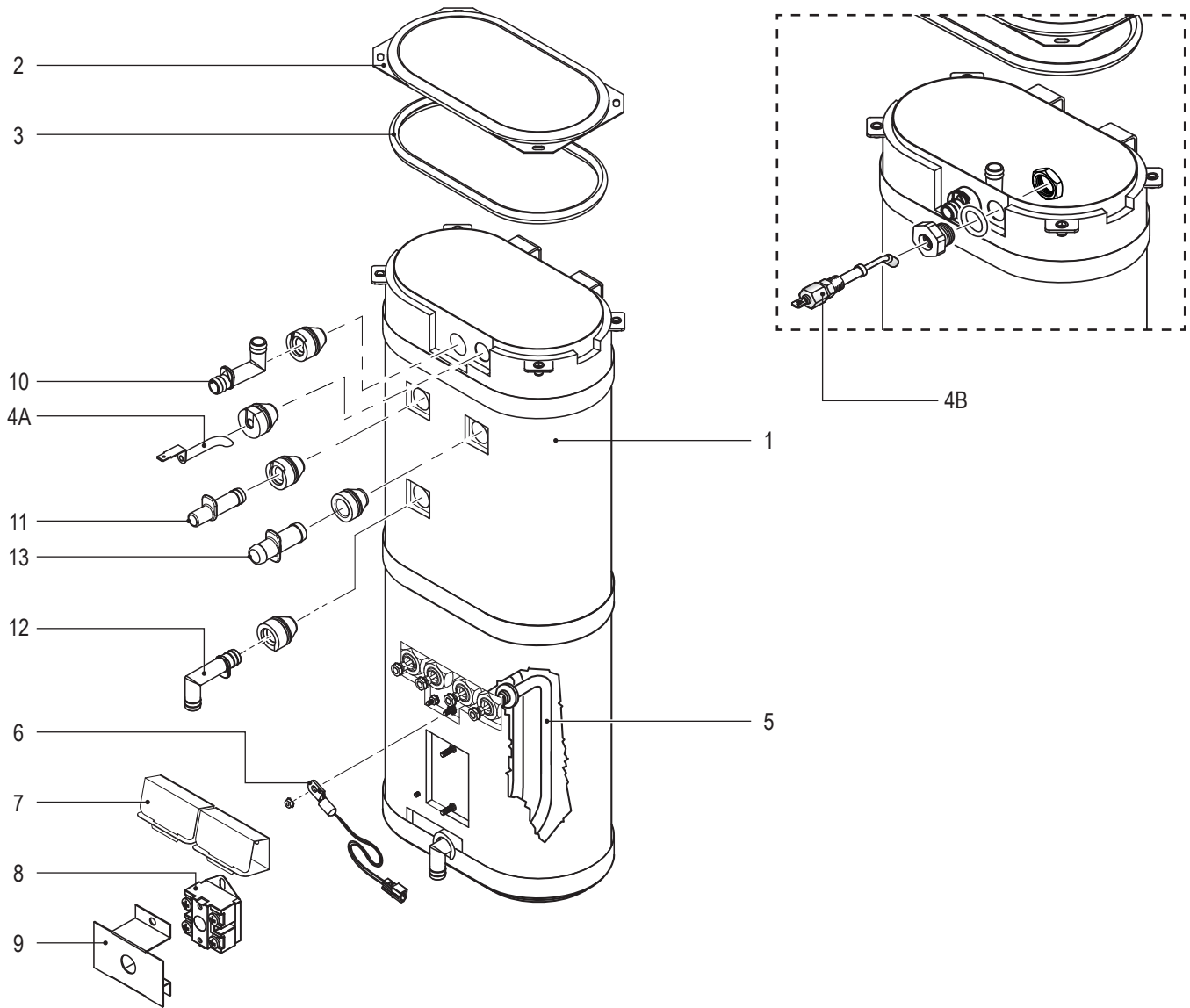

WC-62034 - Tank Assembly - Parts List

ITEM #	PART #	DESCRIPTION
1	WC-62034	TANK, COMPLETE GEMSS DV W/ ULTEM FITINGS
2	WC-5853-102	COVER, TOP HEATING TANK GEN USE
3*	WC-43062	GASKET, TANK LID
4A ¹	WC-5528K	KIT, WATER LEVEL PROBE, SILICONE
4B ²	WC-5502-01	KIT, PROBE, ASSY WATER LEVEL W/HEX FITTING, O-RING & NUT
5*	WC-904-04	KIT, ELEMENT, HEATING 1.6KW120V W/ JAM NUT & SILICONE O-RING
6*	WC-1438-101	SENSOR, TEMPERATURE TANK
7*	WC-4394	GUARD, SHOCK/HEATING ELEMENT FOR SINGLE HEATING ELEMENT

ITEM #	PART #	DESCRIPTION
8*	WC-522	THERMOSTAT, HI LIMIT HEATER CONTROL DPST 277V 40A
9*	WC-43055	GUARD, SHOCK RESET THERMOSTAT (WC-522)
10*	WC-37266	KIT, FITTING TANK OVERFLOW
11*	WC-37317	KIT, STRAIGHT FITTING & BUSHING 8mm GEN USE
12*	WC-37365	KIT, FITTING TANK INLET
13*	WC-37357	KIT, STRAIGHT PLASTIC FITTING AND BUSHING 12MM

¹ Units built 01/04/2019 and later.

² Units built before 01/04/2019. Replaces WC-5527.

* Recommended parts to stock.

GEMSIF10A1000, GEMSIF10B1000

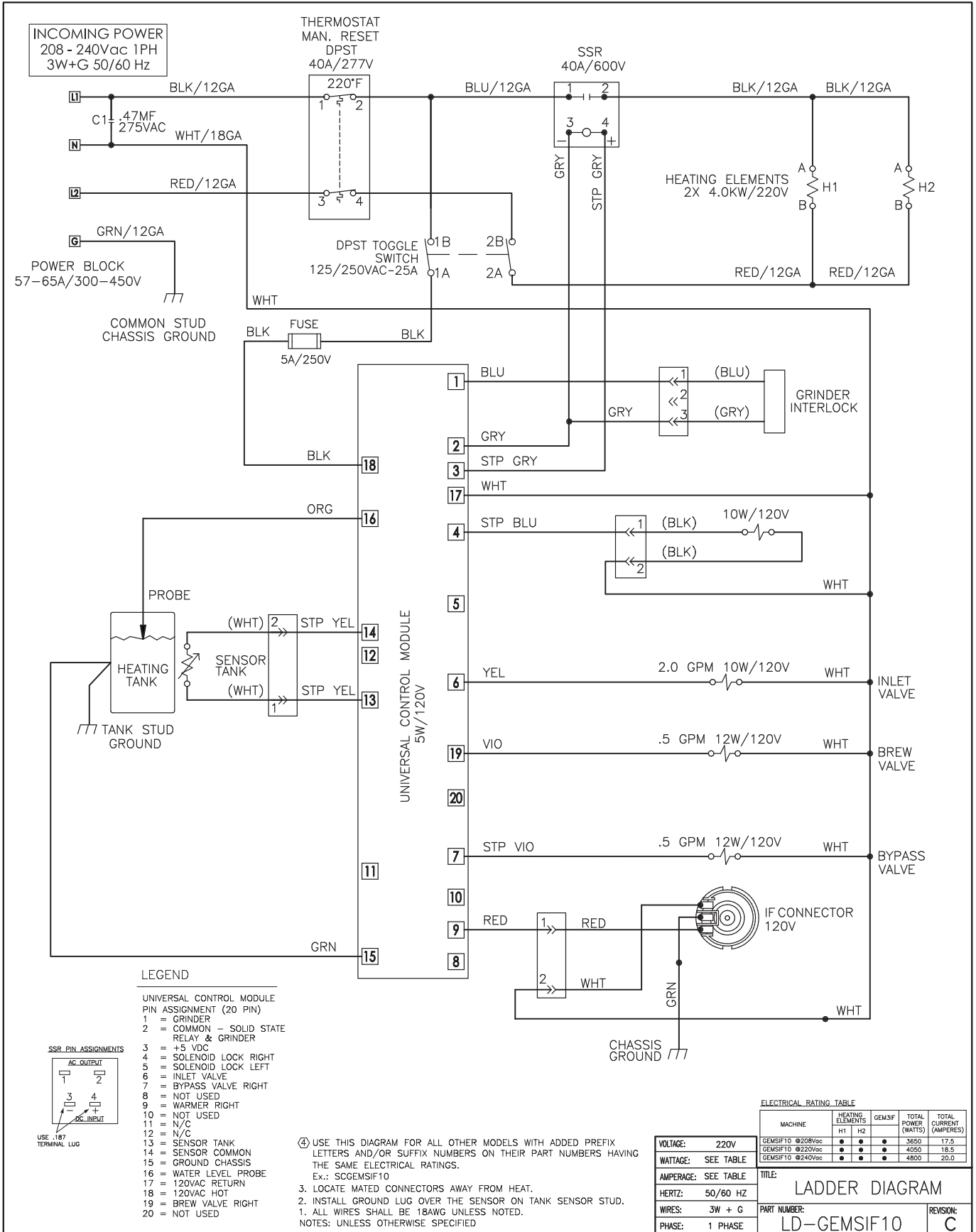

GEMSIF63A1000

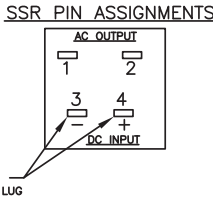
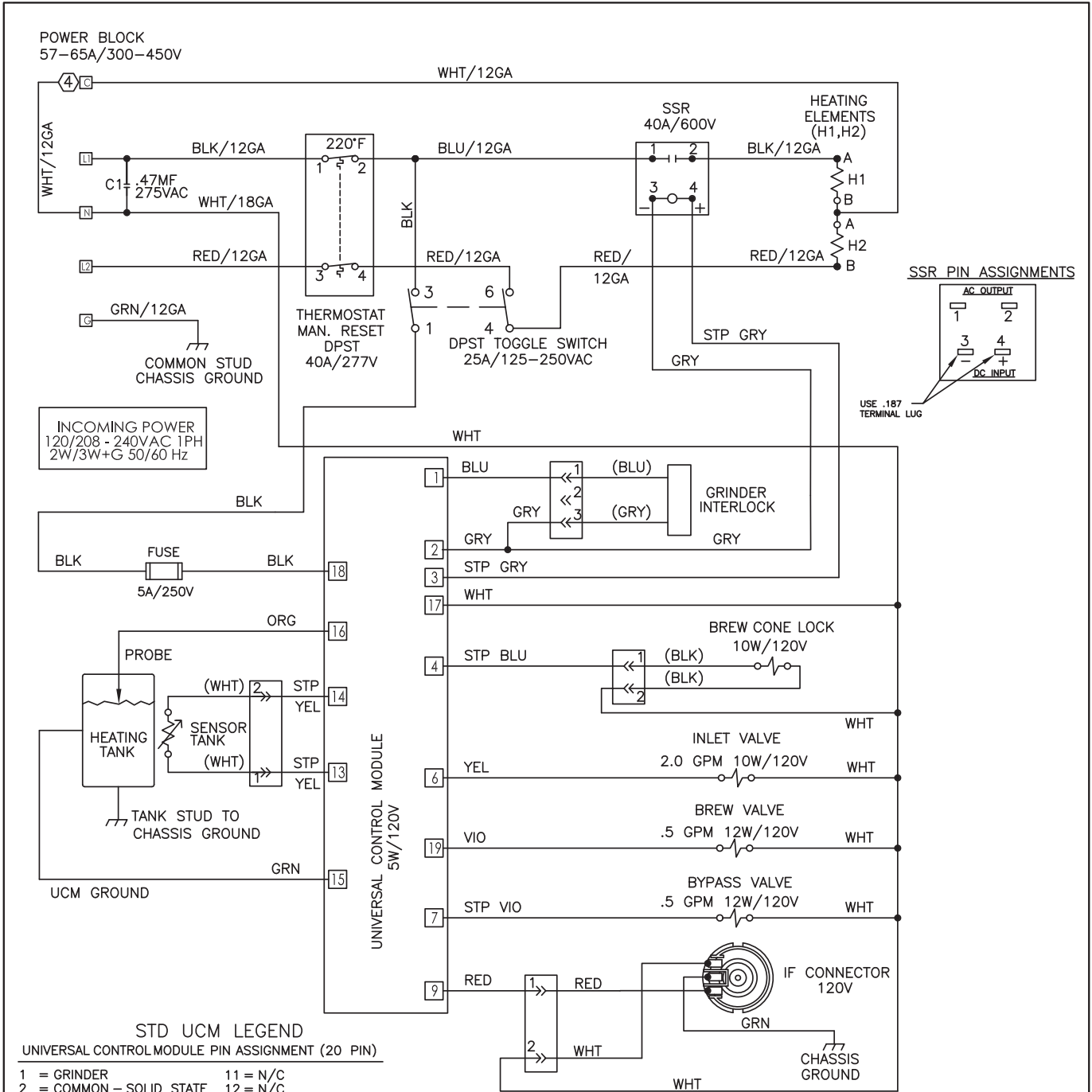

INCOMING POWER
120/208 - 240VAC 1PH
2W/3W+G 50/60 Hz

FUSE
5A/250V

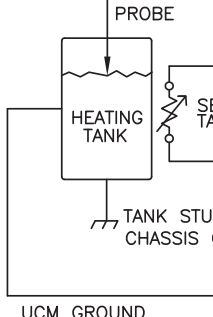

STD UCM LEGEND
UNIVERSAL CONTROL MODULE PIN ASSIGNMENT (20 PIN)

- 1 = GRINDER
- 2 = COMMON - SOLID STATE RELAY & GRINDER
- 3 = +5 VDC
- 4 = SOLENOID LOCK RIGHT
- 5 = NOT USED
- 6 = INLET VALVE
- 7 = BYPASS VALVE RIGHT
- 8 = NOT USED
- 9 = IF WARMER RIGHT
- 10 = NOT USED
- 11 = N/C
- 12 = N/C
- 13 = SENSOR TANK
- 14 = SENSOR COMMON
- 15 = UCM GROUND
- 16 = WATER LEVEL PROBE
- 17 = 120VAC RETURN
- 18 = 120VAC HOT
- 19 = BREW VALVE RIGHT
- 20 = NOT USED

- ④ 12GA WHT WIRE IS ONLY USED WHEN UNIT IS TO BE USED IN THE 120VAC CONFIGURATION.
- ③ SEE LD-GEM3IF FOR WIRING SPECIFICATIONS.
- ② USE THIS DIAGRAM FOR ALL OTHER MODELS WITH ADDED PREFIX LETTERS AND/OR SUFFIX NUMBERS ON THEIR PART NUMBERS HAVING THE SAME ELECTRICAL RATINGS.
- 1. ALL WIRES SHALL BE 18AWG PER UL1015.
- NOTES: UNLESS OTHERWISE SPECIFIED

ELECTRICAL RATING TABLE

GEMSIF	HEATING ELEMENTS (H1,H2)	TOTAL POWER (WATTS)	TOTAL CURRENT (AMPERES)
-52 110/220	1x 1.15KW/2x 1.15KW	1200/2050	10.0/10.0
-52 120/240	1x 1.15KW/2x 1.15KW	1200/2400	10.0/10.0
-63 110/220	1x 1.6KW/2x 1.6KW	1650/2800	13.5/13.5
-63 120/240	1x 1.6KW/2x 1.6KW	1650/3300	13.5/13.5

VOLTAGE: SEE TABLE	TITLE: LADDER DIAGRAM
WATTAGE: SEE TABLE	
AMPERAGE: SEE TABLE	
HERTZ: SEE TABLE	
WIRES: 2W/3W + G	
PHASE: 1 PHASE	PART NUMBER: LD-GEMSIF63
	REVISION: E

GEMSIF30A1000, GEMXSIFT30A1000

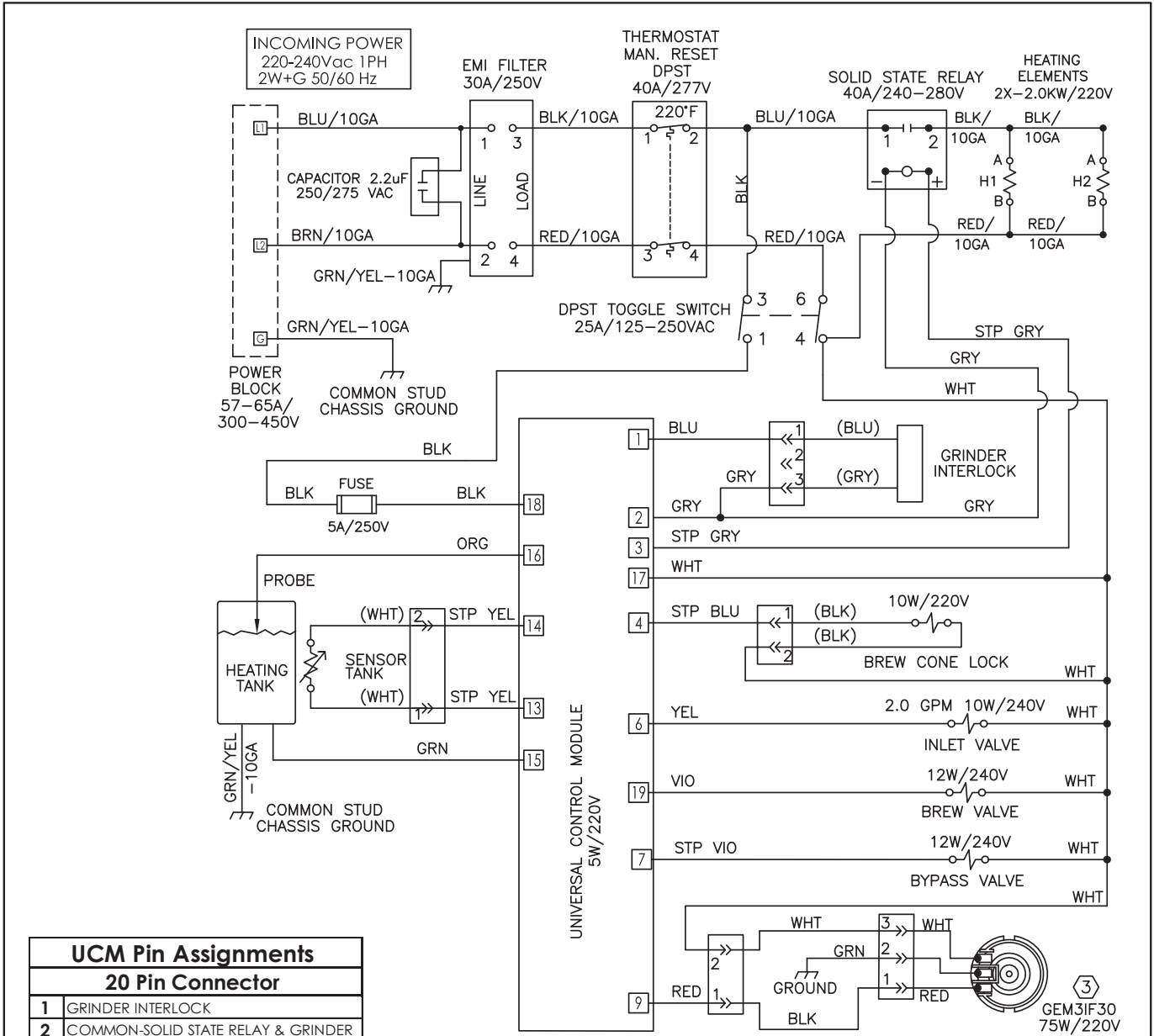

UCM Pin Assignments	
20 Pin Connector	
1	GRINDER INTERLOCK
2	COMMON-SOLID STATE RELAY & GRINDER
3	SOLID STATE RELAY +5 Vdc
4	BREW CONE LOCK
5	NOT USED
6	INLET VALVE
7	BYPASS VALVE
8	NOT USED
9	IF WARMER
10	NOT USED
11	NOT USED
12	NOT USED
13	TANK TEMPERATURE SENSOR
14	TANK TEMPERATURE SENSOR
15	UCM GROUND
16	WATER LEVEL PROBE
17	220-240V L2
18	220-240V L1
19	BREW VALVE
20	NOT USED

ELECTRICAL RATING TABLE									
Model	Voltage V	Amps A	Watts W	Hertz Hz	# of Conductor Wires	Phase	# of Tank Elements	Tank Element Rating W/V	Warmer Element Rating W/V
GEMSIF30x	220	18.5	4050	50/60	2	1	2	2000W/220V	(1X) 75W/220V
	230	19.2	4426						
	240	20.0	4800						

- ③ SEE LD-GEM31F-30 FOR WIRING SPECIFICATIONS.
2. USE THIS DIAGRAM FOR ALL OTHER MODELS WITH ADDED PREFIX LETTERS AND/OR SUFFIX NUMBERS ON THEIR PART NUMBERS HAVING THE SAME ELECTRICAL RATINGS.
1. ALL WIRES SHALL BE MIN 18AWG PVC/UL1015 UNLESS NOTED.
- NOTES: UNLESS OTHERWISE SPECIFIED

SSR PIN ASSIGNMENTS

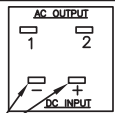

VOLTAGE: SEE TABLE	TITLE: LADDER DIAGRAM
WATTAGE: SEE TABLE	PART NUMBER: LD-GEMSIF-30
AMPERAGE: SEE TABLE	REVISION: B
HERTZ: SEE TABLE	
WIRES: 2W + G	
PHASE: 1 PHASE	

GEMTIF10A1000, GEMTIF10B1000

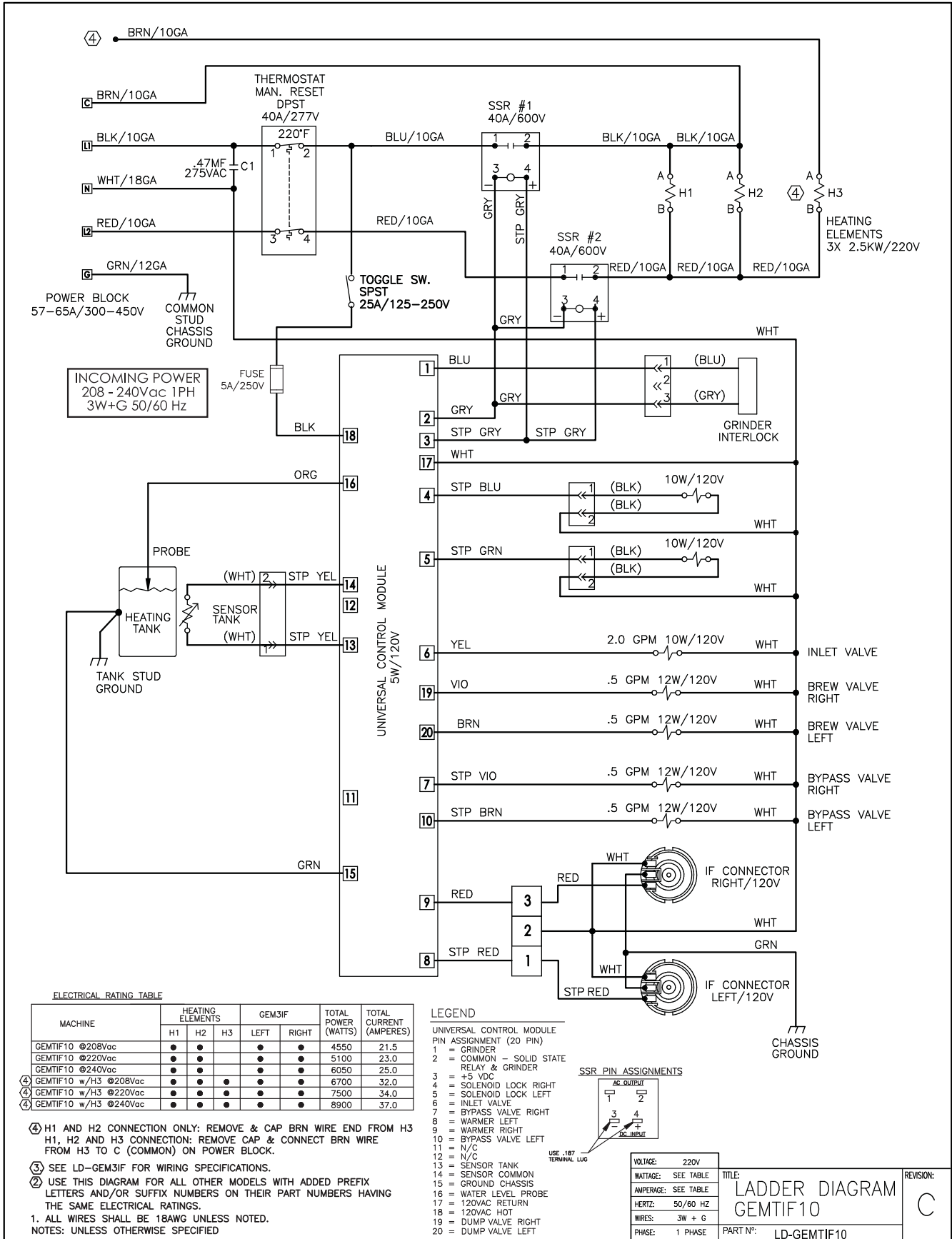

GEMTIF30A1000, GEMXTIFT30A1000

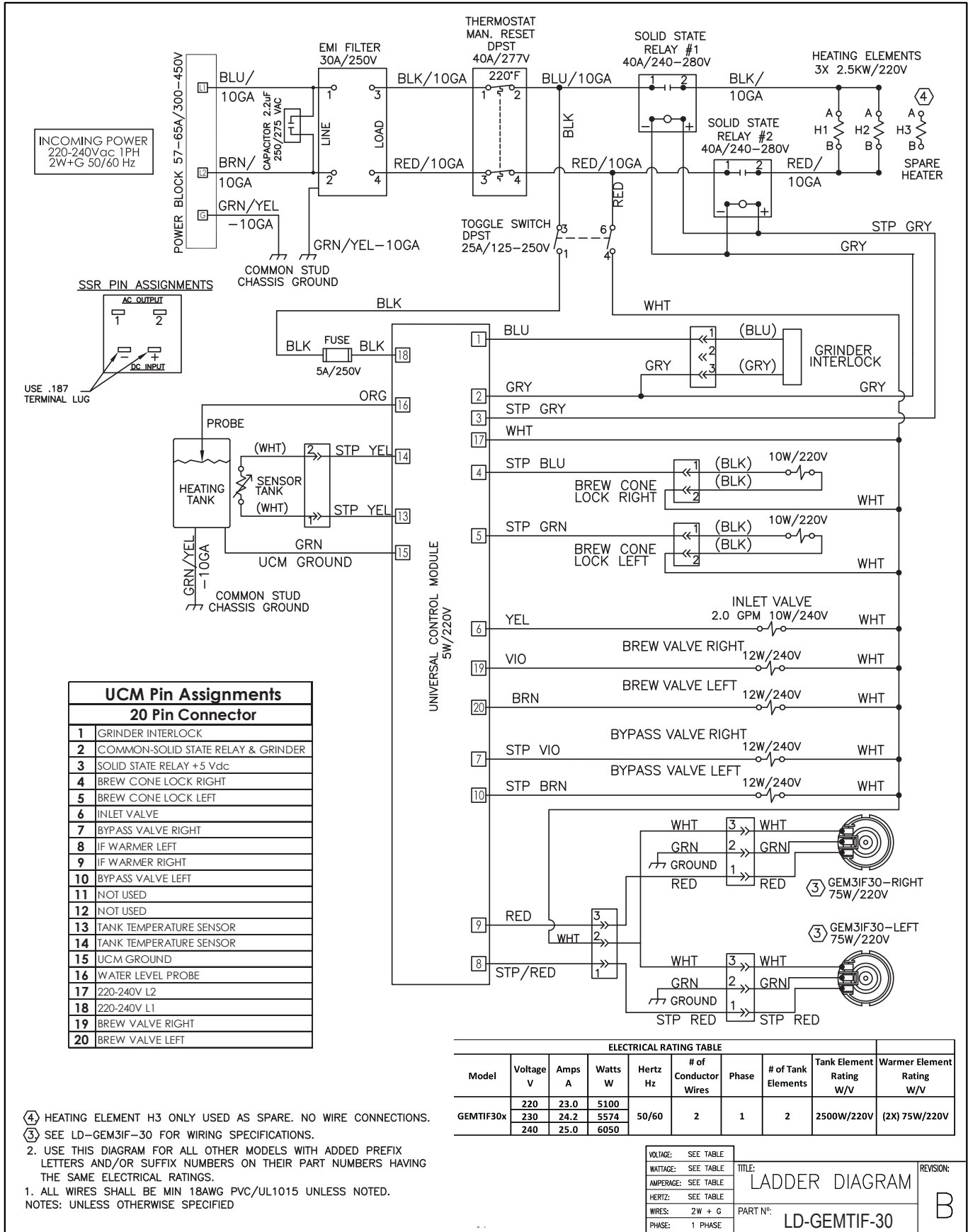

GEM3IF

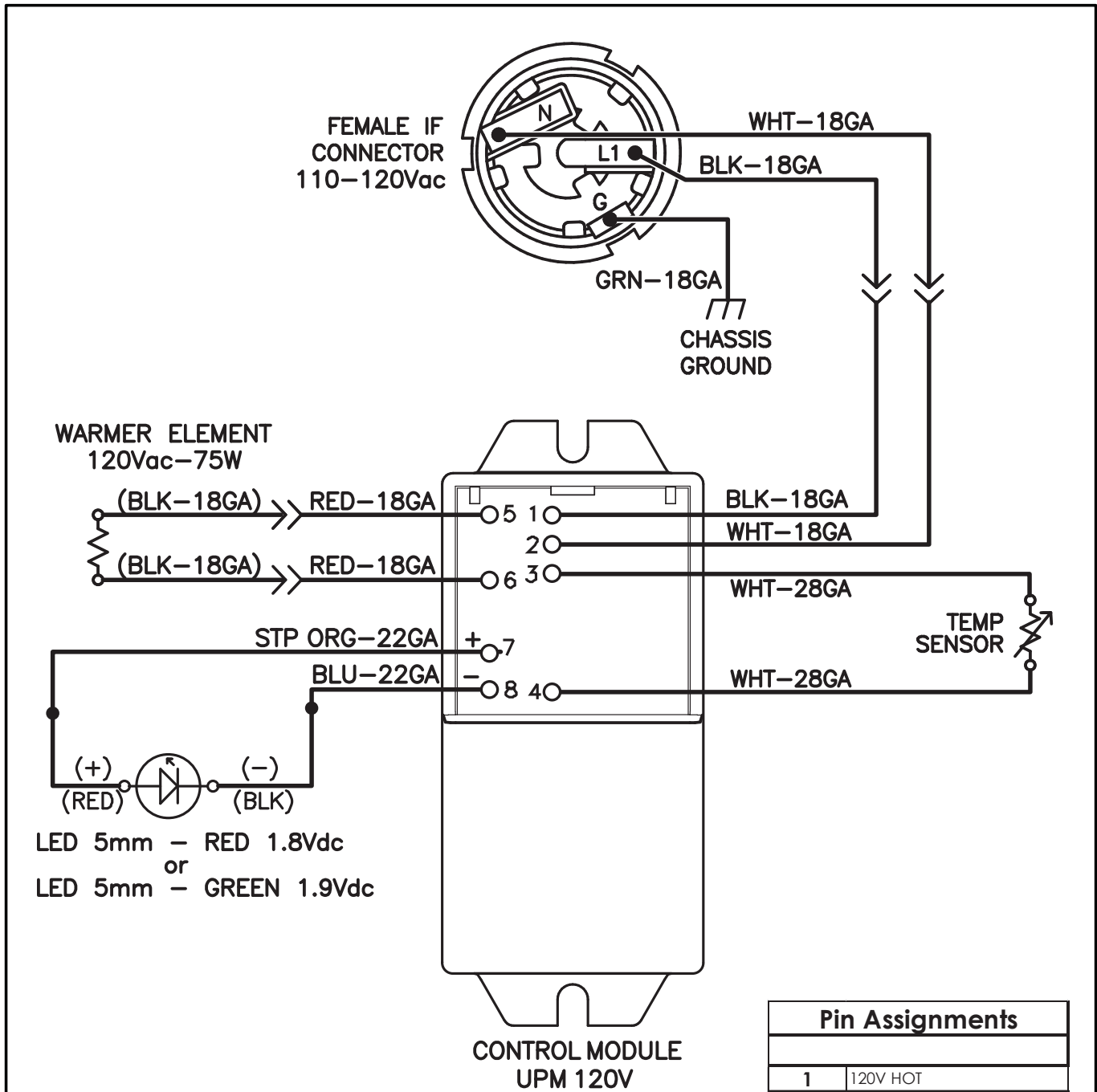

Pin Assignments	
1	120V HOT
2	120V NEUTRAL
3	TANK TEMPERATURE SENSOR
4	TANK TEMPERATURE SENSOR
5	HEATER/WARMER OUT
6	HEATER/WARMER OUT
7	LED (+)
8	LED (-)

ELECTRICAL RATING TABLE						
Model	Voltage V	Amps A	Watts W	Hertz Hz	# of Conductor Wires	Phase
GEM3IFx	110	0.55	60	50/60	2	1
	115	0.58	67	50/60	2	1
	120	0.60	71	50/60	2	1

2. USE THIS DIAGRAM FOR ALL OTHER MODELS WITH ADDED PREFIX LETTERS AND/OR SUFFIX NUMBERS ON THEIR PART NUMBERS HAVING THE SAME ELECTRICAL RATINGS.
 1. ALL WIRES SHALL BE MIN 200°C UNLESS NOTED, GAGE AS NOTED.
 NOTES: UNLESS OTHERWISE SPECIFIED

VOLTAGE: SEE TABLE	TITLE: LADDER DIAGRAM PART NUMBER: LD-GEM3IF REVISION: J
WATTAGE: SEE TABLE	
AMPERAGE: SEE TABLE	
HERTZ: SEE TABLE	
PHASE: SEE TABLE	

GEM3IF-30

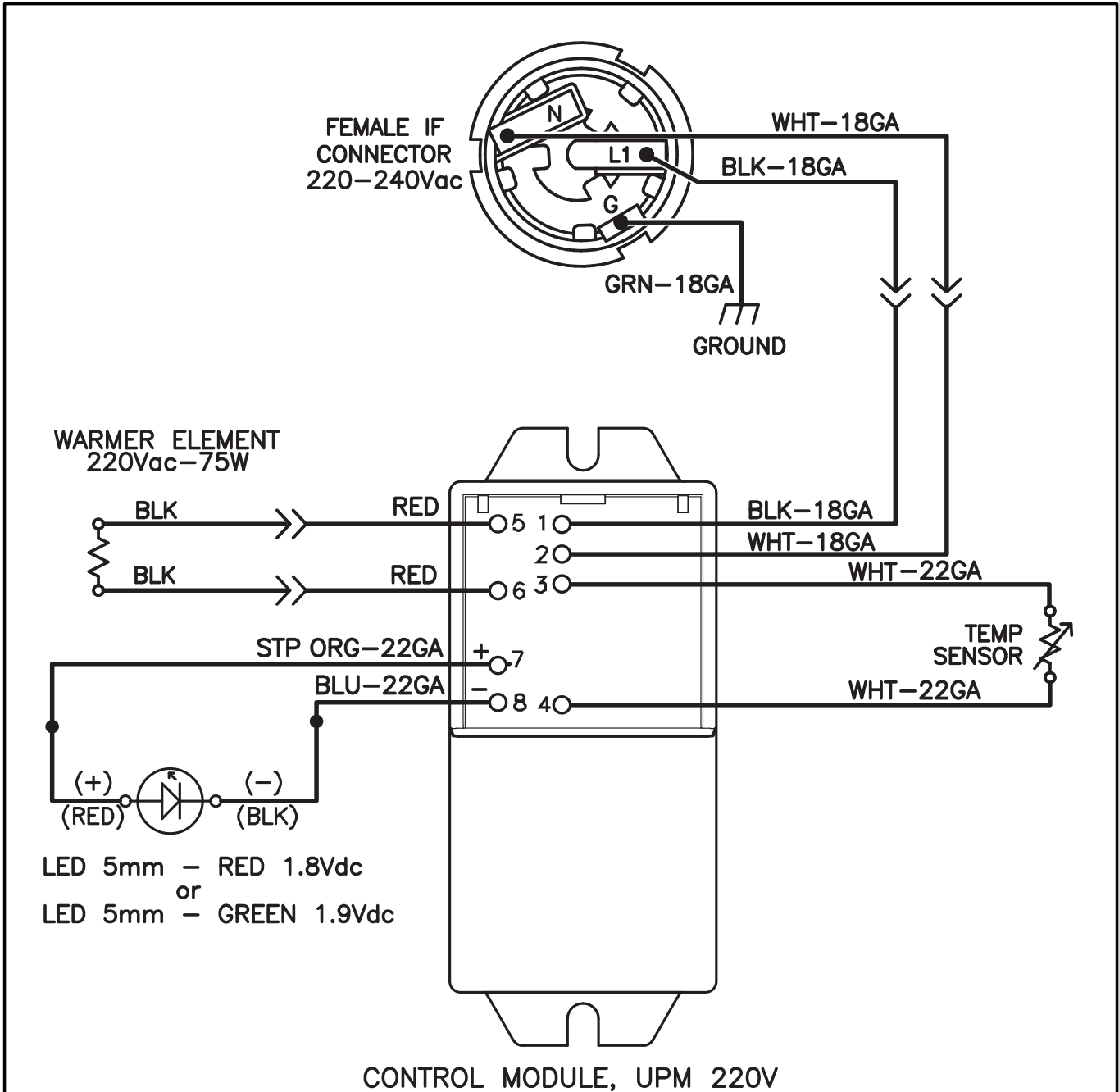

ELECTRICAL RATING TABLE						
Model	Voltage V	Amps A	Watts W	Hertz Hz	# of Conductor Wires	Phase
GEM3IF30x	220	0.34	75	50/60	2	1
	230	0.36	82	50/60	2	1
	240	0.37	89	50/60	2	1

2. USE THIS DIAGRAM FOR ALL OTHER MODELS WITH ADDED PREFIX LETTERS AND/OR SUFFIX NUMBERS ON THEIR PART NUMBERS HAVING THE SAME ELECTRICAL RATINGS.
 1. ALL WIRES SHALL BE MIN 18AWG PVC/UL1015 UNLESS NOTED.
 NOTES: UNLESS OTHERWISE SPECIFIED

VOLTAGE: SEE TABLE	TITLE: LADDER DIAGRAM
WATTAGE: SEE TABLE	
AMPERAGE: SEE TABLE	
HERTZ: SEE TABLE	
WIRES: SEE TABLE	
PHASE: SEE TABLE	PART NUMBER: LD-GEM3IF-30
	REVISION: A

**WARNING:**

Electric Shock Hazard - the following procedures are to be performed only by a qualified service technician. Disconnect power when replacing components. Lock out and tag the circuit breaker on units without a power plug. Neither Wilbur Curtis Co., Inc. nor the seller can be held responsible for the interpretation of this information, or any liability in connection with its use.

Scald and Burn Hazard - keep body parts clear of hot surfaces during troubleshooting.



IMPORTANT: If it is necessary to replace the G3 universal control module (UCM), always check all inlet, dump (brew), bypass* and dilution* valve coils for a short and replace the valve as necessary, before replacing the module. See the *Valve Test Procedure*, below to test for defective valves. *Some units do not have this function, see the *ELECTRICAL SCHEMATIC*.

Troubleshooting Guidelines

- If an error message appears on the display, consult the *ERROR CODES* section before troubleshooting.
- A brewer that is not level may not function properly. Make sure the brewer is properly leveled before proceeding.
- This troubleshooting guide identifies some, but not all, of the possible causes for common problems that can occur.
- Use this troubleshooting guide along with the appropriate *ELECTRICAL SCHEMATIC*.

Valve Test Procedure

Use a digital multi-meter to measure the resistance of valve coils.

Measure the resistance across the valve coil terminals with the wiring harness disconnected. Reverse the meter leads on the terminals and measure the resistance in the opposite direction. A resistance of less than 100 ohms, in either direction, indicates a shorted coil. The valve must be replaced.

If a shorted coil is not detected, test for an open coil:

- 1 Reconnect the valve terminals to the wiring harness.
- 2 Power up the brewer with the appropriate cover removed to allow access to the valve.
- 3 Run a brew cycle while monitoring the voltage at the valve coil terminals. If voltage is present on the terminals, you should hear the valve click open/closed at the moment power is applied or removed from the terminals. The inlet valve should open any time the water tank is not full. If the valve does not open, replace the valve. If voltage is not detected, first check the wiring. If the wiring is OK, replace the UCM.

Water Not Hot Enough

- 1 If the water heats, but is not hot enough, first check for the correct temperature setting on the control panel. Reprogram as necessary.
- 2 If the temperature setting is OK, and the actual water temperature does not match setting on the control panel, replace the temperature sensor.

Water Heats More Slowly Than Usual

- 1 Check for power across the terminals of the heating element(s). If power is being supplied, disconnect the heating element(s) and check for continuity. Replace a heating element if the resistance is too high (nominal resistance is 13 Ohms).
- 2 If there is no power to the heating element(s), check the wiring to any element that does not have the proper voltage across it. Also check for corroded connections anywhere between the power cord and the heating element(s).

Dispenser Overflows During Brewing

- 1 Check to make sure the control module (UCM) brew, bypass* and dilution* levels are set properly.
- 2 Check for a missing spray head. Replace as needed.
- 3 Make sure the dispenser is empty before starting the brew cycle. If not, empty it before brewing.

*Some units do not have this function, see the *ELECTRICAL SCHEMATIC*.

No Power - Display Not Lit

- 1 Make sure the circuit breaker to the circuit supplying power to the brewer is not tripped and is turned on.
- 2 On brewers with a power plug, make sure it is connected to the power receptacle.
- 3 Make sure that the main power toggle switch on the back panel is turned ON.
- 4 Verify that all wires from the power cord are properly connected inside the unit. Check to make sure the wires are not burned/overheated. Loose connections can create heat. Check chassis ground.
- 5 Check to make sure power and ground are being supplied to the control module (UCM). If there is power into UCM, but display is blank, UCM is probably bad.
- 6 If there is no power into the UCM, trace the circuit back (using the wiring diagram) to the power cord to find out where power is lost. If there is power into the thermostat reset switch, but not out, see step 7.
- 7 If there is power into the thermostat reset switch, but not out, check to make sure that the water tank is not empty. If the tank is empty, the reset switch has probably opened up due to a low water level, go to *Water Tank Does Not Fill*. If there is water in the tank, but no power out, push in on the reset switch button to see if it restores power. If power is restored, check to make sure that the switch is not opening up at the wrong temperature (the switch should not open up at normal water temperatures). If there is still no power through the switch after pushing the button, replace the thermostat reset switch.

Brewer Does Not Start When Brew Button is Pressed

- 1 If **Brewing** appears on the display, check for faulty wiring and connections between the universal control module (UCM) and the valves.
- 2 If **Brewing** does not appear on the display, check for a faulty universal control module (UCM).

Sensor Error Message

This error indicates a malfunction (open circuit) in the temperature sensor system. Once the malfunction is corrected, the error message must be cleared. To reset the brewer and return to normal operation, turn the toggle switch on the back of the brewer to the OFF position for 5 seconds, then back ON.

- 1 Check the resistance across the leads of the temperature sensor while it is disconnected from the universal control module (UCM). If an open circuit is measured (resistance above 200 k), replace the sensor.
- 2 If the sensor resistance is less than 200 k check the sensor wires for corrosion and reconnect them to the UCM. Afterward, if the error message comes back after resetting the control and power modules, replace the UCM.

Water Tank Overfills

- 1 Turn the toggle switch on the back of the brewer ON and OFF. If water continues to flow when the switch is in both positions, replace the inlet valve.
- 2 If water stops flowing to the water tank when the toggle switch is turned OFF and continues when the switch is turned back ON, remove the orange wire from the water probe on the tank. While power is ON, short the end of the orange wire to the metal surface on the outside of the tank. If the water tank stops filling when the orange wire is shorted to the tank, check for a corroded connection at the water probe.
- 3 If water does not stop flowing when the orange wire is shorted to the tank, check the tank ground connection and the continuity of the orange wire connecting to the universal control module (UCM). If both are OK, replace the UCM.

Water Tank Does Not Fill



IMPORTANT: No water or low water in the tank can cause the tank to overheat, resulting in the thermostat reset switch opening. If after correcting a tank fill problem there is no power to the control panel, push the reset switch button to reset.

- 1 Check to make sure the water supply is turned on. Check for a clogged water supply line, water filter or plugged inlet valve.
- 2 If there are no plugs in the water supply line, check for power across the inlet valve terminals. If power is being supplied, but there is no water flow, replace the inlet valve.
- 3 If power is not being supplied to the inlet valve, check the wires between the universal control module (UCM) and the inlet valve. Check for corroded connections.
- 4 If the wiring between the UCM and the inlet valve is OK, but there is no power to the inlet valve, remove the orange wire from the water tank probe. If the water tank starts to fill, replace the water probe. If the water tank does not start to fill, replace the UCM.

Coffee/Tea Too Strong

See *Dispenser Not Filled To Normal Level During Brewing*.

Dispenser Not Filled To Normal Level During Brewing

- 1 Check to make sure that the universal control module (UCM) brew, bypass* and dilution* levels are set properly.
- 2 Check to make sure that the flow rate and water pressure from the water supply line meet the minimum specifications for the brewer. See the **SPECIFICATIONS** section.
- 3 Check to make sure that the spray head is clean and free of debris. Clean or replace as needed. Also make sure that the spray head is correctly aligned and that the tubing is routed properly to allow for maximum water flow (no kinks).
- 4 Remove the brew basket and place a large container under the dump (brew) and dilution outlet points. Run a brew cycle and confirm that the dump (brew) valve, bypass* valve and dilution* valve open during the brew cycle. Check for flow through any exit point that is slow or non-existent. Not all valves open at the same time. If flow is restricted, check for obstructions in the related tubing or valve. If there are no obstructions, but flow through one particular valve is slow, it can be assumed that the particular valve is not opening all the way and should be replaced. If water does not flow at all through a particular valve during the brew cycle, check to make sure that power is being supplied to the valve in question. Replace any valve that is not opening when power is applied to the terminals. If power is not being supplied to the valve, check the wiring between the valve and the UCM. If the wiring is OK, replace the UCM.

*Some units do not have this function, see the **ELECTRICAL SCHEMATIC**.

Dispenser Overflows All Of The Time

- 1 Check to see if water continues to flow from the spray head, the bypass* outlet or the dilution* spout when the toggle switch is turned OFF. Replace any valve that is stuck open.
*Some units do not have this function, see the *ELECTRICAL SCHEMATIC*.
- 2 If one or more of the valves mentioned in step 1 turns on when the toggle switch on the back is ON and turns off when the switch is OFF, replace the universal control module (UCM).

No Water/Tea Flows From Brewer During Brewing

- 1 Make sure that the water supply is turned on.
- 2 Check to see if the water in the tank is level with the water tank probe? If not, see *Water Tank Does Not Fill*.
- 3 If the water tank is full, the water is hot and power is on, but NO water flows during a brew cycle, the problem is usually a bad universal control module (UCM). Run a brew cycle and check for power from the UCM to the dump (brew), bypass* and dilution* valves. If there is no power output, replace the UCM.
*Some units do not have this function, see the *ELECTRICAL SCHEMATIC*.

Low Water Flow Warning

See *Water Level Error Message*.

Water Level Error Message

Water level fill error or overflow. This error message occurs when the inlet valve solenoid has been on too long during initial fill or tank refill, See the *ERROR CODES* section for the maximum times allowed. Once the malfunction is corrected, the error message must be cleared. To reset the unit and return to normal operation, turn the toggle switch on the back of the brewer to the OFF position for 5 seconds, then back ON.

- 1 Check to make sure that the water filter is not clogged.
- 2 Check to make sure that the flow rate from the water supply line meets the minimum flow rate specifications for the brewer. Also check the water pressure. See the *SPECIFICATIONS* section.
- 3 Check for blockage at the inlet valve inlet and outlet and that it opens completely. Check for blockage in the tubing between the inlet valve and the water tank.
- 4 Check the water probe wire for an open condition or corroded connections.
- 5 If the probe connections are OK, cycle power to the unit by turning the rear toggle switch OFF, then ON. Check to see if power is applied to the inlet valve terminals. If power is applied to the terminals, but there is not water flow, replace the inlet valve.
- 6 Check for power from the universal control module (UCM) to the inlet valve. If the wiring is OK, replace the UCM.

Water Does Not Heat At All

- Check to see if the water level in the tank is in contact with the water level probe. If not, see *Tank Does Not Fill*. The water will not heat unless it is in contact with the probe.
- If the water heats, but is not hot enough, see *Water Not Hot Enough*.
- If **Ready to brew** appears on the display, but the water is not hot, check the resistance across the leads of the temperature sensor. If the resistance is less than 10 k and the water is not hot, replace the temperature sensor. If the sensor resistance is above 10 k when the water is cool, replace the universal control module (UCM).

If **Heating...** appears on the display, but the water is not hot, follow the steps below. The following steps are performed with the rear toggle switch in the ON position.

- 1 Check for power across the terminals of the heating element(s). If power is being supplied, remove the wires and check for an open heating element.
- 2 If there is no power to the element(s), trace the circuit back (using the ELECTRICAL SCHEMATIC) to the power cord to find out where power is lost. If there is power into the solid state relay(s) (SSRs) but not out, see the following step. On units having two SSRs, be sure to check both.
- 3 If there is power into a SSR, but not out, check for 5 Vdc (nominal*) across the + and - pins of the SSR(s). If there is 5 Vdc across the + and - pins of the SSR(s), but no (or low) output voltage at a SSR output terminal, replace the SSR. If 5 Vdc is not being supplied from the UCM, but **Heating...** appears on the display, check the wiring from the UCM to the SSR(s). If the wiring is OK, replace the UCM.

Water Too Hot (Boiling or Excessive Steaming)



IMPORTANT: Before proceeding, make sure that the control panel temperature is adjusted to compensate for higher elevations. The factory setting is 200°F. Reduce the temperature setting two degrees for every 1000 feet of elevation above 4000 feet.

- 1 If **Over Temp Sensor** or **Ready to Brew** appears on the display and the water is too hot, go to *Over Temp Sensor Error Message*.
- 2 If the display reads **Heating** constantly, first check to make sure that the temperature sensor is attached tightly to the tank and that heat sink compound was used. A properly mounted sensor should have a resistance of around 7 k when the water is hot. If not, replace the sensor.
- 3 Check to see if the universal control module (UCM) constantly has +5 Vdc output (nominal) to the solid state relay (SSR), regardless of the resistance of the temperature sensor. If so, the UCM is probably bad.
- 4 If the UCM is working properly, check for a shorted SSR.

Over Temp Sensor Error Message

This error message indicates that the universal control module (UCM) has detected a water overheating problem. The UCM is reading a water temperature in the tank above 210°F. If the water temperature is too hot, but **Heating...** appears on the display, see *Water Too Hot*. Once the malfunction causing the error is corrected, the error message must be cleared. To reset the brewer and return to normal operation, turn the toggle switch on the back of the brewer to the OFF position for 5 seconds, then back on.

- 1 Check for 5 Vdc (nominal) across the + and - pins of the solid state relay (SSRs). If no power is applied to the SSR and the heating elements are always on, replace the SSR. On units having two SSRs, check both.
- 2 Turn off power to the brewer and allow the water tank to cool. Once cool, turn power back on while monitoring the voltage across the + and - pins of the SSR(s). During normal operation, the voltage should be 5 Vdc, until the water is hot, then drop to below 1 Vdc. The UCM should be replaced if the voltage reads 5 Vdc constantly even though **Ready to brew** or **Over Temp Sensor** appears on the display.
- 3 If the UCM is operating normally, check for a false over-temp error caused by the temperature sensor. Check the resistance across the leads of the temperature sensor. If the resistance is less than 10 k when the water is cool, replace the temperature sensor.

Satellite Does Not Heat

NOTE: The satellite heating element is designed to keep brewed coffee hot, but is not of sufficient wattage to reheat cold coffee.

- 1 First check to see if the LED on the satellite is flashing an error code. Three long and one short indicates a bad heating element. Three long and two short flashes indicate a defective sensor circuit on the controller (replace the controller).
- 2 Check to make sure that the warmer is not turned off. See the *PROGRAMMING GUIDE* section.
- 3 Check to see if the IntelliFresh LED on the front of the satellite comes on at the beginning of the brew cycle. If neither the LED nor the warmer come on, then it can be assumed that there is no power to the satellite. Make sure that power is being supplied to the IntelliFresh (IF) connector on the brewer when the BREW button is pressed. The voltage varies based on the model, see the *ELECTRICAL SCHEMATIC*. If power is present at the connector, check the connector contacts. If power is not present at the IF connector, trace the circuit back to the control module to see if it is supplying power to the IF connector.
- 4 Check the contacts on the satellite IF connector to make sure that they are making good contact with the connector on the brewer.
- 5 If the satellite is receiving power from the IF connector and there are no error codes, suspect the controller.

LED Does Not Light (Warmer OK)

- 1 Check the LED. It should have continuity in one direction using a digital multimeter (DMM).
- 2 If the LED is OK, suspect the controller.

System Fault Messages

An error message will appear on the screen in the event of a malfunction under the following conditions:

- 1 Water level overflow. This error indicates that either there is not enough incoming water flow/pressure or a water overflow condition (unit will stop functioning).
- 2 Break in temperature control circuit.
- 3 Excess temperature in heating tank.

If any of the errors below appear on the screen, turn off the main power toggle switch and call for service.

ERROR MESSAGE	WARNING DESCRIPTION	CAUSE
Water Level Error	Fill run error/Overflow	The water inlet valve has either been open for more than 10 minutes on the initial tank fill or has been open for more than 30 seconds* in normal operation.
Sensor Error	Open Probe	Break in the temperature thermistor circuit.
Over Temp. Error	Excess Temperature	The sensor is reading that temperature in the heating tank has risen above 210°F (99°C).

* 120 seconds for models with water tanks larger than 2 gallons.

Wilbur Curtis Co., Inc. certifies that its products are free from defects in material and workmanship under normal use. The following limited warranties and conditions apply:

- 3 years, parts and labor, from original date of purchase on digital control boards
- 2 years, parts, from original date of purchase on all other electrical components, fittings and tubing
- 1 year, labor, from original date of purchase on all other electrical components, fittings and tubing

Additionally, Wilbur Curtis Co., Inc. warrants its grinding burrs for forty (40) months from the date of purchase or 40,000 pounds of coffee, whichever comes first. Stainless steel components are warranted for two (2) years from the date of purchase against leaking or pitting. Replacement parts are warranted for ninety (90) days from the date of purchase or for the remainder of the limited warranty period of the equipment in which the component is installed.

All in-warranty service calls must have prior authorization. For authorization, call the Technical Support Department at 800-995-0417. Additional conditions may apply. Go to www.wilburcurtis.com to view the full product warranty information.

CONDITIONS & EXCEPTIONS

The warranty covers original equipment at time of purchase only. Wilbur Curtis Co., Inc., assumes no responsibility for substitute replacement parts installed on Curtis equipment that have not been purchased from Wilbur Curtis Co., Inc. Wilbur Curtis Co., Inc. will not accept any responsibility if the following conditions are not met. The warranty does not cover:

- **Adjustments and cleaning:** *The resetting of safety thermostats and circuit breakers, programming and temperature adjustments are the responsibility of the equipment owner. The owner is responsible for proper cleaning and regular maintenance of this equipment.*
- **Replacement of items subject to normal use and wear:** *This shall include, but is not limited to, spray heads, faucets, light bulbs, shear disks, "O" rings, gaskets, silicone tubing, silicone elbows, canister assemblies, whipper chambers and plates, mixing bowls, agitation assemblies and whipper propellers.*

The warranty is void under the following circumstances:

- **Improper operation of equipment:** *The equipment must be used for its designed and intended purpose and function.*
- **Improper installation of equipment:** *This equipment must be installed by a professional technician and must comply with all local electrical, mechanical and plumbing codes.*
- **Improper voltage:** *Equipment must be installed at the voltage stated on the serial plate supplied with this equipment.*
- **Improper water supply:** *This includes, but is not limited to, excessive or low water pressure and inadequate or fluctuating water flow rate.*
- **Damaged in transit:** *Equipment damaged in transit is the responsibility of the freight company and a claim should be made with the carrier.*
- **Abuse or neglect (including failure to periodically clean or remove lime accumulations):** *The manufacturer is not responsible for variation in equipment operation due to excessive lime or local water conditions. The equipment must be maintained according to the manufacturer's recommendations.*

Repairs and/or Replacements are subject to Curtis' decision that the workmanship or parts were faulty and the defects showed up under normal use. All labor shall be performed during regular working hours. Overtime charges are the responsibility of the owner. Charges incurred by delays, waiting time, or operating restrictions that hinder the service technician's ability to perform service is the responsibility of the owner of the equipment. This includes institutional and correctional facilities. Wilbur Curtis Co., Inc. will allow up to 100 miles, round trip, per in-warranty service call.

Return Merchandise Authorization (RMA): All claims under this warranty must be submitted to the Wilbur Curtis Technical Support Department prior to performing any repair work or return of this equipment to the factory. **All returned equipment must be properly re-packaged in the original carton and received by Curtis within 45 days following the issuance of a RMA.** No units will be accepted if they are damaged in transit due to improper packaging. **NO UNITS OR PARTS WILL BE ACCEPTED WITHOUT A RETURN MERCHANDISE AUTHORIZATION (RMA). THE RMA NUMBER MUST BE MARKED ON THE CARTON OR SHIPPING LABEL. All warranty claims must be submitted within 60 days of service. Invoices will not be processed or accepted without a RMA number. Any defective parts must be returned in order for warranty invoices to be processed and approved.** All in-warranty service calls must be performed by an authorized service agent. Call the Wilbur Curtis Technical Support Department to find an agent near you.