



Gemini® Satellite



Style varies

See brewer user guide for brewing instructions

READ AND SAVE THESE INSTRUCTIONS

NOTICE TO INSTALLER: Please leave this booklet with the machine.

Important Safeguards IS7
Cleaning Instructions CI3
Rough-In Drawing RD80
Illustrated Parts/Recommended Parts IP136
Product Warranty PW1

Contact Information

Wilbur Curtis Co., Inc.

6913 Acco Street | Montebello, CA 90640 US
Phone: 323-837-2300 | Toll Free: 800-421-6150
Email: cstrassistance@wilburcurtis.com | Web: www.wilburcurtis.com

For the latest specifications and information go to www.wilburcurtis.com
Toll Free: 800-995-0417 | Monday - Friday 5:30 A.M. - 4:00 P.M. PT
Email: techsupport@wilburcurtis.com

Due to continued product improvement, the products illustrated/photographed in this guide may vary slightly from the actual product.

Symbols



This is the safety alert symbol. It is used to alert you to potential physical injury hazards. Obey all safety messages that follow this symbol to avoid possible injury or death.



DANGER - Indicates a hazardous situation which, if not avoided, will result in death or serious injury.



WARNING - Indicates a hazardous situation which, if not avoided, could result in death or serious injury.



CAUTION - Indicates a hazardous situation which, if not avoided, could result in minor or moderate injury.



NOTICE - Indicates a situation which, if not avoided, could result in property damage.



IMPORTANT - Provides information and tips for proper operation.



SANITATION REQUIREMENTS



WARNING - This product can expose you to chemicals including Acrylamide and Bisphenol A (BPA), which are known to the State of California to cause cancer and birth defects or other reproductive harm. For more information visit www.P65Warnings.ca.gov.

Important Safeguards/Conventions



WARNING:

- Keep hands, arms and other items away from hot surfaces.
- Clean the dispenser completely before using it for the first time as according to the CLEANING INSTRUCTIONS. Clean it regularly as instructed in the CLEANING INSTRUCTIONS. Do not use harsh powders or cleansers containing chlorine. Do not use a wire brush or pot scour to clean inside liner. When cleaning dispensers with a connector on the back, do not allow liquids to get into the connector during cleaning.
- Dispensers may be heavy when filled. Take care when transporting to avoid dropping or spilling.
- Use this unit only for its intended use, serving hot and/or cold beverages/water.
- This dispenser is not intended for use by persons (including children) with reduced physical, sensory or mental capabilities or lack of experience and knowledge, unless they have been given supervision or instruction concerning use of the dispenser by a person responsible for their safety.

CE Requirements

- This appliance must be installed in locations where it can be overseen by trained personnel.
- For proper operation, this appliance must be installed where the temperature is between 5°C to 35°C.
- Appliance shall not be tilted more than 10° for safe operation.
- An electrician must provide electrical service as specified in conformance with all local and national codes. For safe use, an all-pole disconnection must be incorporated into the fixed wiring in accordance with the wiring rules outlined in clause 7.12.2 of IEC 60335 for meeting the minimum electrical safety of this standard.
- This appliance must not be cleaned by water jet.
- This appliance can be used by persons aged from 18 years and above if they have been given supervision or instruction concerning use of the appliance in a safe way and if they understand the hazards involved.
- Keep the appliance and its cord out of reach of children aged less than 18 years.
- Appliances can be used by persons 18 years and above with reduced physical, sensory or mental capabilities or lack of experience and knowledge if they have been given supervision or instruction concerning use of the appliance in a safe way and understand the hazards involved.
- Children under the age of 18 years should be supervised to ensure they do not play with the appliance.
- If the power cord is ever damaged, it must be replaced by the manufacturer or authorized service personnel with a special cord available from the manufacturer or its authorized service personnel in order to avoid a hazard.
- Machine must not be immersed for cleaning.
- Cleaning and user maintenance shall not be made by children unless they are older than 18 years and supervised.
- This appliance is intended to be used in household and similar applications such as:
 - staff kitchen areas in shops, offices and other working environments;
 - by clients in hotels, motels and other residential type environments;
 - bed and breakfast type environments.
- This appliance not intended to be used in applications such as:
 - farm houses
- Access to the service areas permitted by Authorized Service personnel only.
- The A-Weighted sound pressure level is below 70 dBA.

Disposal of Equipment

- This product contains plastic, metal and electronic components and is considered e-waste. At the end of its life, this product must not be disposed of in normal household waster but can be instead delivered to a collection point for recycling electric and electronic appliances, consult with the local municipality for proper disposal guidelines.

Cleaning the Satellite (Daily)

The following cleaners are required to properly maintain the satellite:

- Mild solution of dish-washing detergent and warm water
- TABZ™ Z95 Coffee Equipment Cleaner Tablets (Curtis PN WC-79000)
- One-Pro Beverage Equipment Cleaner



WARNING: DO NOT immerse the satellite in water or any other liquid. Do not place the satellite in a dishwasher. Doing so will void the warranty. Do not use harsh powders or cleansers containing chlorine. Do not use a wire brush or scouring pad to clean inside the liner. **To avoid damage, DO NOT use a brush to clean the faucet or the inside of the faucet shank (outlet).**

Cleaning the Liner

- 1 Remove the satellite from the brewer and remove the lid. Set the lid aside. Rinse out the liner.
- 2 **Wash** - Prepare a mild solution of detergent and warm water. Wipe the exterior surfaces of the satellite with a sponge moistened with the detergent solution to remove spills and debris. Fill the liner with the detergent solution. Take a sponge brush and scrub out the stainless steel liner.
- 3 **Rinse** - Rinse with clean, warm water.
- 4 **Sanitize** - Drop one TABZ Z95 tablet into the liner. Fill the liner up to the top with hot water (122°F/50°C min.). Stir the contents. Allow the liner to soak for 5 to 10 minutes.
- 5 Open the faucet and drain out the sanitizer (to clean the faucet shank).
- 6 Fill the liner to the top with clean, warm water and drain through the faucet (to rinse the faucet shank).
- 7 Fill the liner to the top with water a second time and drain through the faucet.
- 8 Disassemble the faucet - Unscrew the handle/bonnet assembly from the top of the faucet and remove it. Inspect the seat cup for wear. Replace the seat cup if it is damaged.

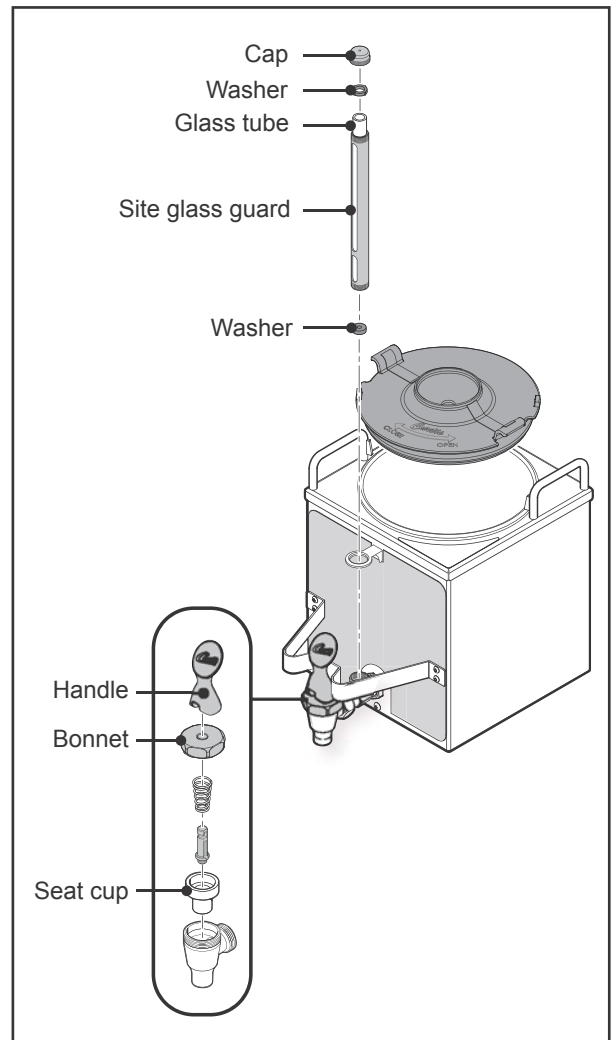

Disassemble the sight gauge (some versions). Remove the cap and unscrew the guard, as shown, to disassemble the gauge. Remove the glass tube. Inspect it for cracks or chips. If broken, replace the glass with a new one.

- 9 **Air Dry** - Turn the satellite upside down and allow it to air dry.

continued...

Cleaning the Faucet Parts and Site Gauge

- 10 **Wash** - Wash the lid and all faucet and gauge glass parts with the detergent solution. Clean the inside of the gauge glass with a gauge brush soaked with detergent solution.
- 11 **Rinse** - Thoroughly rinse all parts with clean, warm water.
- 12 **Sanitize** - After rinsing, place the lid and all faucet and gauge parts in a sink to be sanitized. Immerse them in One-Pro cleaner mixed at a ratio of 1 oz. (28 g.) per 5 gal. (19 L) of hot water (122°F/50°C min.). Allow the parts to soak for 15 minutes.
- 13 **Air Dry** - Allow all parts to thoroughly air dry.
- 14 **Reassemble** - When dry, reassemble the handle/bonnet. Hand tighten the handle/bonnet onto the top of the faucet assembly. Reinstall the site gauge (if applicable). If replacing a broken gauge glass, carefully remove any traces of glass from the silicone parts before inserting the new gauge glass tube. Reinstall the lid.

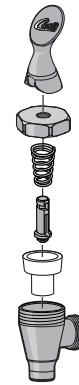
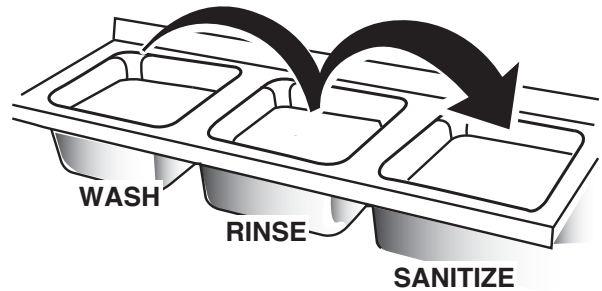

GEM-3 - Satellite Server

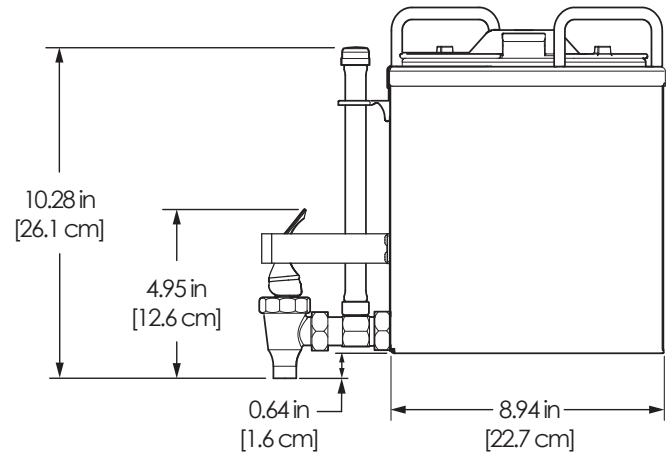
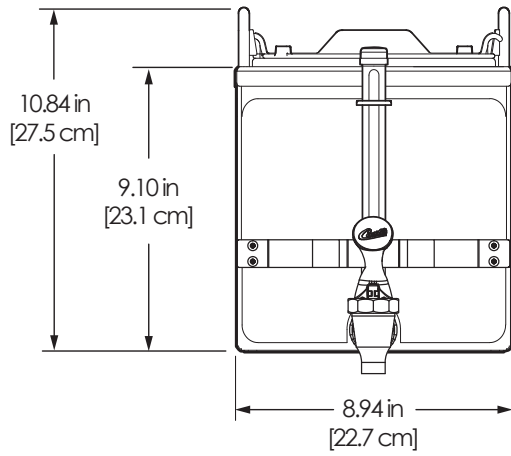
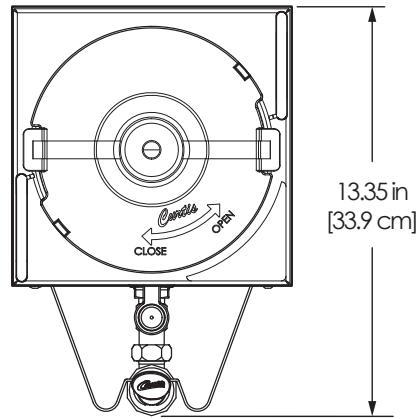

GEM-3[D] - Exploded View

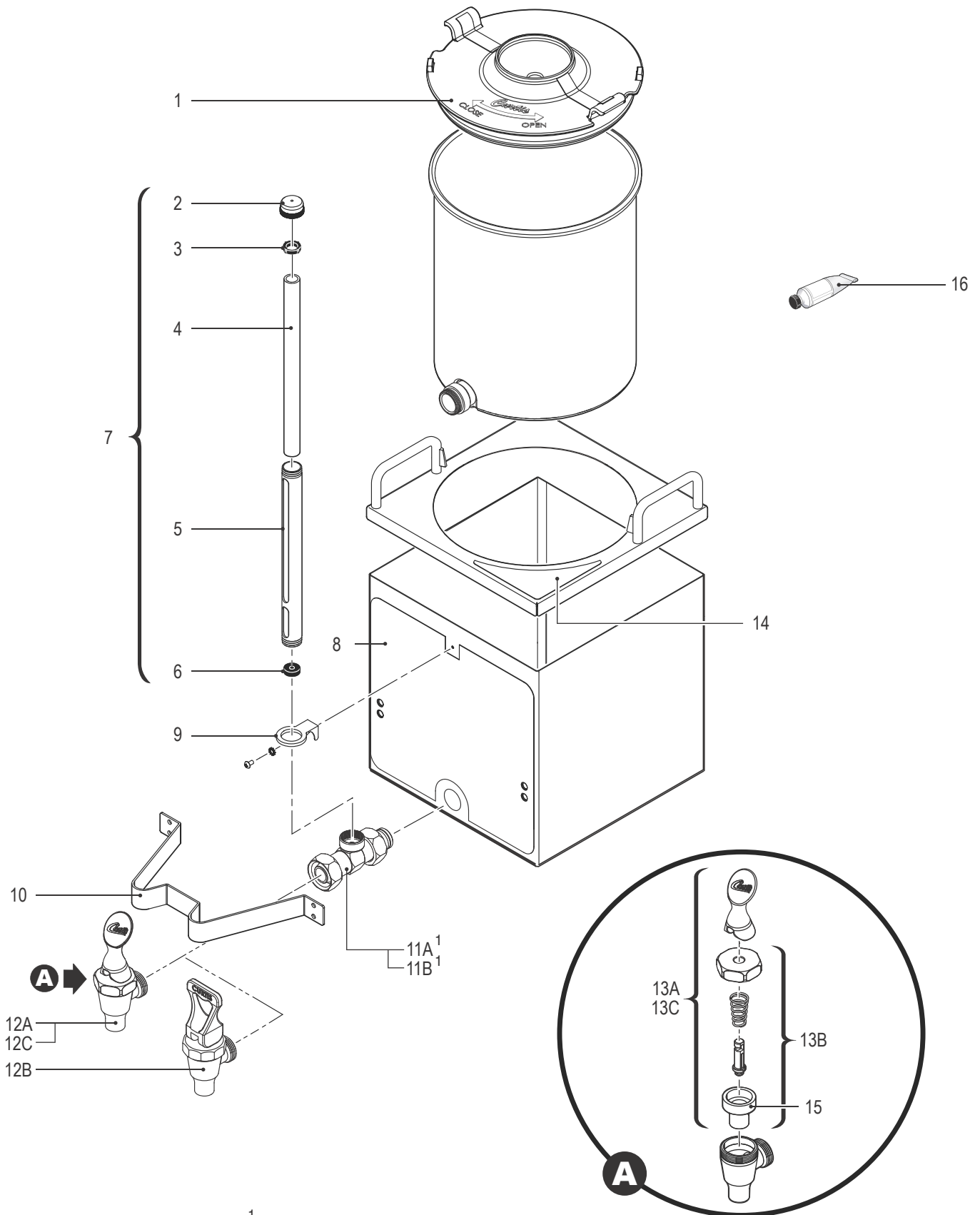

¹ When replacing the faucet shank, apply food grade lubricant (ITEM 16, not included) to both o-rings before installation.

GEM-3[D] - Main Chassis - Parts List

ITEM #	PART #	DESCRIPTION
1*	WC-5622	LID, SATELLITE PLASTIC GEM-3
2	WC-2001	CAP, SHIELD W/VENT 77-4 GEN USE
3*	WC-2005	WASHER, SHIELD CAP 1/8" GEM-3/TC'S W/SG
4*	WC-2025	GLASS, GAUGE 8"
5	WC-2010C	SHIELD, GAUGE GLASS 3/4"D.X 8"
6*	WC-2006	WASHER, .188 ID X .188 THK BOTTOM GAUGE GLASS GEN USE
7	WC-2102	GAUGE GLASS, ASSY 8"C
8	WC-39049	LABEL, FRONT GEM-3 CURTIS
9	WC-2007	BRACKET, GAUGE GLASS GEM-3
10	WC-6417	GUARD, FAUCET GEM-3
11A	WC-1901A-103 ^{1,2}	SHANK ASSY, FAUCET W/SHIELD BASE O-RING STYLE
11B	WC-1901A ¹	SHANK, FAUCET W/SHIELD BASE

¹ When replacing the faucet shank, apply food grade lubricant (ITEM 16, not included) to both o-rings before installation.

² For units built after 11/16/15

* Recommended parts to stock.

ITEM #	PART #	DESCRIPTION
12A*	WC-1800	FAUCET,"S" SERIES BLK LOCKING 1-1/32-14 UNS CURTIS
12B	WC-1800-CH	FAUCET, "S" SERIES NONLOCKING 1-1/32-14 UNS CLASSIC
12C	WC-1800D	FAUCET,"S" SERIES ORANGE HNDLE 1-1/32-14 UNS
13A	WC-3705	KIT, FAUCET S SERIES NONLOCK USE ON WC-1800
13B	WC-3705-101	KIT, FAUCET BONNET ASSY
13C	WC-3705D	KIT, FAUCET S SERIES DECAF NON LOCK USE ON WC-1800D
14	WC-38151	LABEL, LOCK/UNLOCK GEM-3
15*	WC-1805	SEAT CUP, "S" FAUCET USE ON WC-1800/B/LB/D/DL/L/WC-1803
16	WC-4916	LUBRICANT, GREASE HEAVY DUTY PC'S 4oz

Wilbur Curtis Co., Inc. certifies that its products are free from defects in material and workmanship under normal use. The following limited warranties and conditions apply:

- 3 years, parts and labor, from original date of purchase on digital control boards
- 2 years, parts, from original date of purchase on all other electrical components, fittings and tubing
- 1 year, labor, from original date of purchase on all other electrical components, fittings and tubing

Additionally, Wilbur Curtis Co., Inc. warrants its grinding burrs for four (4) years from the date of purchase. Stainless steel components are warranted for two (2) years from the date of purchase against leaking or pitting. Replacement parts are warranted for ninety (90) days from the date of purchase or for the remainder of the limited warranty period of the equipment in which the component is installed.

All in-warranty service calls must have prior authorization. For authorization, call the Technical Support Department at 800-995-0417. Additional conditions may apply. Go to www.wilburcurtis.com to view the full product warranty information.

CONDITIONS & EXCEPTIONS

The warranty covers original equipment at time of purchase only. Wilbur Curtis Co., Inc., assumes no responsibility for substitute replacement parts installed on Curtis equipment that have not been purchased from Wilbur Curtis Co., Inc. Wilbur Curtis Co., Inc. will not accept any responsibility if the following conditions are not met. The warranty does not cover:

- **Adjustments and cleaning:** *The resetting of safety thermostats and circuit breakers, programming and temperature adjustments are the responsibility of the equipment owner. The owner is responsible for proper cleaning and regular maintenance of this equipment.*
- **Replacement of items subject to normal use and wear:** *This shall include, but is not limited to, spray heads, faucets, light bulbs, shear disks, "O" rings, gaskets, silicone tubing, silicone elbows, canister assemblies, whipper chambers and plates, mixing bowls, agitation assemblies and whipper propellers.*

The warranty is void under the following circumstances:

- **Improper operation of equipment:** *The equipment must be used for its designed and intended purpose and function.*
- **Improper installation of equipment:** *This equipment must be installed by a professional technician and must comply with all local electrical, mechanical and plumbing codes.*
- **Improper voltage:** *Equipment must be installed at the voltage stated on the serial plate supplied with this equipment.*
- **Improper water supply:** *This includes, but is not limited to, excessive or low water pressure and inadequate or fluctuating water flow rate.*
- **Damaged in transit:** *Equipment damaged in transit is the responsibility of the freight company and a claim should be made with the carrier.*
- **Abuse or neglect (including failure to periodically clean or remove lime accumulations):** *The manufacturer is not responsible for variation in equipment operation due to excessive lime or local water conditions. The equipment must be maintained according to the manufacturer's recommendations.*
- **Unauthorized repair or modification:** *This equipment must be serviced only by qualified service technicians, using factory specified parts to factory specifications.*
- **Modified/Missing Serial Tag:** *The serial number label (tag) must not be defaced or removed.*

Repairs and/or Replacements are subject to Curtis' decision that the workmanship or parts were faulty and the defects showed up under normal use. All labor shall be performed during regular working hours. Overtime charges are the responsibility of the owner. Charges incurred by delays, waiting time, or operating restrictions that hinder the service technician's ability to perform service is the responsibility of the owner of the equipment. This includes institutional and correctional facilities. Wilbur Curtis Co., Inc. will allow up to 100 miles, round trip, per in-warranty service call.

Return Merchandise Authorization (RMA): All claims under this warranty must be submitted to the Wilbur Curtis Technical Support Department prior to performing any repair work or return of this equipment to the factory. **All returned equipment must be properly re-packaged in the original carton and received by Curtis within 45 days following the issuance of a RMA.** No units will be accepted if they are damaged in transit due to improper packaging. **NO UNITS OR PARTS WILL BE ACCEPTED WITHOUT A RETURN MERCHANDISE AUTHORIZATION (RMA). THE RMA NUMBER MUST BE MARKED ON THE CARTON OR SHIPPING LABEL. All warranty claims must be submitted within 60 days of service. Invoices will not be processed or accepted without a RMA number. Any defective parts must be returned in order for warranty invoices to be processed and approved.** All in-warranty service calls must be performed by an authorized service agent. Call the Wilbur Curtis Technical Support Department to find an agent near you.