

Curtis WILBUR CURTIS COMPANY, INC.

Service Manual – Expressions Multi-flavor

Models Included:

- EXPR

 **WARNING HOT LIQUID**, Scalding may occur. Avoid splashing.

 **CAUTION:** Use this setup procedure before attempting to use this appliance. Failure to follow the instructions can result in injury or the voiding of the warranty.

 **CAUTION:** DO NOT connect this unit to hot water. Inlet valve not rated for hot water.

 **WARNING, HOT LIQUID**



WILBUR CURTIS COMPANY
Montebello, CA 90640

Important Safeguards/Conventions

This appliance is designed for commercial use. Any servicing other than cleaning and maintenance should be performed by an authorized Wilbur Curtis service center.

- Do NOT immerse the unit in water or any other liquid
- To reduce the risk of fire or electric shock, do NOT open top panel. No user serviceable parts inside. Repair should be done only by authorized service personnel.
- Keep hands and other items away from hot parts of unit during operation.
- Never clean with scouring powders or harsh implements.

Conventions

 **WARNINGS – To help avoid personal injury**

 **Important Notes/Cautions – from the factory**

 **Sanitation Requirements**

Your Curtis G3 System is Factory Pre-Set and Ready to Go, Right from the Carton.

Following are the Factory Settings for your Expressions Multi-flavor Beverage System:

- **Tank Temperature = 190°F**
- **Dispensing Mode Set for Manual Dispense**

Generally there will never be a reason to change your G3 programming. However, should you need to make slight adjustments to meet your dispensing needs, programming instructions are provided later in this manual.

System Requirements:

- **Water Source** 20 – 90 PSI (Minimum Flow Rate of 1 GPM)
- **Electrical:** See attached schematic for standard model or visit www.wilburcurtis.com for your model.

Equipment to be installed to comply with applicable federal, state, or local plumbing/electrical codes having jurisdiction.

SETUP STEPS

The unit should be level (left to right and front to back), located on a solid counter top.

Connect a water line from the water filter to the brewer.

NOTE: Some type of water filtration device must be used to maintain a trouble-free operation. (In areas with extremely hard water, we suggest that a sedimentary and taste & odor filter be installed.) This will prolong the life of your dispensing system and enhance cappuccino product quality.

 NSF International requires the following water connection:

1. A quick disconnect or additional coiled tubing (at least 2x the depth of the unit) so that the machine can be moved for cleaning underneath.
2. This equipment is to be installed with adequate back flow protection to comply with applicable federal, state and local codes..
3. Water pipe connections and fixtures directly connected to a potable water supply shall be sized, installed and maintained in accordance with federal, state, and local codes.

1. Connect a water line from your facility to the 1/4" flare water inlet fitting of the valve, behind the machine. Water volume going to the machine should be stable. Use tubing sized sufficiently to provide a minimum flow rate of one gallon per minute.
2. Plug the power cord into an electrical outlet rated at 20A.
3. Switch on the toggle switch, behind the unit, that runs power to the components in the machine. The lights (display window and row of buttons) on the front door will activate and the heating tank will start to fill.
4. Water in the heating tank will require about one hour to reach operating temperature (factory setting of 190°F). At this time the LCD will display "READY TO DISPENSE".
5. Remove and fill the canisters with powdered product.

Operation Instructions

1. Place your cup under the spout.
2. Decide on a flavor and press the dispensing button for this flavor. Hot cappuccino drink will flow from the dispensing spout into the cup. 
3. Be sure to release the button when the cup is about $\frac{3}{4}$ full. Hot liquid continues to flow for about four seconds after releasing. This is to clear the whipper chamber of remaining product.

FILL CANISTERS DAILY

1. Open the front door to access canisters.
2. Rotate the powder delivery elbows upward.
3. The canisters must be removed from the unit for filling. To remove, lift canister slightly while pulling back off the canister tray.
4. Refill all canisters with product, then reposition them on the machine, aligning the gear socket with the gear on the motor shaft.
5. Rotate the powder delivery elbows downward and close the front door.

Cleaning the Curtis Multi-flavor Beverage Dispenser

CAUTION - Do not use cleansers, liquid bleach, powders or any other substance containing chlorine. These products promote corrosion and will pit the stainless steel. THE USE OF THESE PRODUCTS WILL VOID YOUR WARRANTY.

I. EVERY 3 - 4 HOURS OR MORE OFTEN IF NECESSARY

- A. Make sure power is ON.
- B. Catch rinse water. Place a container on top of the drip tray, below the dispensing spout.
- C. Locate the WASH button on the front control panel. Rinse each flavor by pressing and holding the WASH button, at the same time pressing one of the PUSH dispensing buttons on the control panel. Continue holding WASH until the rinse water runs clear.
- D. Dispose of rinse water container and its contents.

II. DAILY Refer to the daily cleaning instructions on the inside of the front door, see illustration below.

- A. Switch OFF the unit at the power toggle switch, located behind the unit.
- B. Wipe all exterior surfaces with a dampened cloth, removing any spills, residue or dust from the unit.
- C. Remove the drip drawer and louvered screen; then wash out its contents. For hard to clean deposits, use a mild, non-abrasive detergent. Rinse with water.
- D. Wipe and clean the dispensing area with a mild detergent cleaner.
- E. Switch ON the unit at the toggle switch.

III. WEEKLY OR MORE OFTEN IF NECESSARY

- A. Open the front door to locate the whipper assembly. Disassemble and clean the whipper chamber parts with warm water and a mild detergent.
 1. One at a time, lift each canister slightly and rotate the delivery elbow to point upward.
 2. Remove the manifold, pulling back on the spout to release it from the alcove, (illustration right).
 3. Remove the upper mixing cup. Pull cup forward, twist to the left and lift it to separate the upper mixing cup from the lower mixing cup.
 4. To remove the lower mixing cup, pull mixing cup up and forward to free it from the hot water inlet fitting.
 5. Remove the dispensing nozzle from the whipper chamber. Clean the inside using a narrow brush.
 6. Remove the whipper chamber.

- a. Take hold of the whipper chamber with one hand while holding the whipper mounting plate with the other. Turn it clockwise to free it from the mounting plate.
 - b. Remove whipper chamber from the unit and clean it thoroughly.
7. Pull the whipper propeller from the motor shaft and clean it.

IMPORTANT - When replacing the propeller, make sure the propeller is properly aligned and seated on the motor shaft. Some propellers may have an indicator; a wide, flat surface to lineup with the flat on the shaft (illustration, right).

The newer propellers have an embossed **D**, indicating how to position the propeller on the motor shaft. Failure to push the propeller in all the way will cause the propeller to fuse with the whipper chamber. This condition will not be covered under warranty.

8. Clean the mounting plate.
- a. Clean the shaft with a cloth and mild detergent before removing mounting plate.
 - b. Twist the mounting plate clockwise and pull it from the motor shaft.

IMPORTANT - Do not remove pillars to take off mounting plate.

- c. Clean the area behind the mounting plate.
 - d. Clean the water inlet fitting.
 - e. Lubricate the center seal of the mounting plate before reinstalling.
9. Wash and rinse all parts that were removed for cleaning.
9. Allow parts to dry. Assemble the whipper assembly and close the front door.
10. The unit is ready for use.

Steps to Programming

**Your Curtis Generation 3 cappuccino dispenser is Factory Pre-Set for Optimum Performance.
Entering the Programing Menus**

Press and hold **STOP/WASH** for about ten [10] seconds until display reads **Program Menus** (See Illustration). Release button. Scroll through menu using → or ← control button. Select menu items you wish to enter with the Stop/Wash button.

Program Menus

Manual Dispense (Factory Default)

Press **⊙** or **▶** to go to **Manual Dispense Select**.

Press **⊙** to go to **Manual Dispense Select Station**.

Choose the station and press, the display will read **Saving Complete!** To select another station for manual dispense, press **⊙** to go to **Manual Dispense Select Station** or press **▶** to continue to the next menu.

Dispense By Time

The next screen is **Dispense By Time ◀ Select ▶**.



Before making this adjustment and to avoid guessing the time, run a stop watch on the time it takes to fill a cup in the **Manual Dispense** mode. Use the timed results to determine your **Dispense By Time** setting.

Press **⊙** and all station indicator lights will flash. Select a station to program by pressing the **PUSH** button on your chosen station. Screen will show the current setting (from 0.0 to 30.0 seconds, in ½ second increments). Press **▶** to increase the time or **◀** to decrease. To set, press **⊙** and you will exit back to **Dispense by Time** screen. Continue with additional selections or press **▶** to continue to the next menu.

Temperature (Factory set at 190°F)

Press **⊙** and screen will show **Tank Temperature**. Temperature is programmable from 170°F to 204°F in 2-degree increments.

Press **◀** or **▶** to go up or down in degrees. Select desired temperature and then **⊙** to set. Press **▶** to continue to the next menu.

Powder % Ratio

Press **⊙** and the screen will display **Powder Ratio Select Station**. This is shown as **A, B, C, D** and **E**, corresponding to canisters, arranged left to right (when facing the machine), starting with **A**. Press desired station. Powder ratio for each canister flavor is programmable from 0% to 100%, in 5% increments.

Press **◀** or **▶** to increase or decrease ratio and then press **⊙** to set. Press **▶** to continue to the next canister. After **E** the screen returns to **Powder Ratio**. Press **▶** to continue to the next menu.

Service Call (Phone number)

Press **⊙** to display number and press **⊙** change number or **▶** to move places and **EX** to exit when complete This number will be displayed during a Heating system **SENSOR ERROR** or a **WATER ERROR**. Press **▶** to continue to the next menu.

Banner Name

Press **⊙** to display letters, press **⊙** to change letters or **▶** to move places and **EX** to exit when complete.

This feature allows up to 14 letters to be programmed for company name or regional name. Programming all blanks disables Banner Name. If programmed, Banner Name is displayed every 5 sec. on and off. Press **▶** to continue to the next menu.

Exit

Press **⊙** to select, exits program mode and returns unit to operation.

CONFIGURATION OF CANISTERS

MODEL	10 LB. CANISTER P/N CA-1113-06R	ULTRA-SLIM P/N CA-1142-06
EXPR	ONE	FOUR

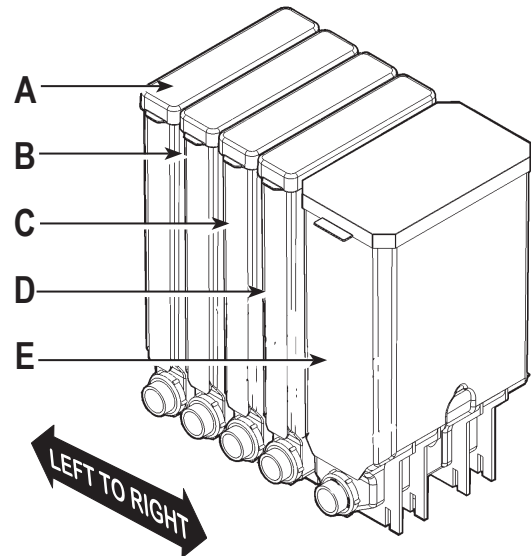

Illustrated Parts List

Item Nº	Part Nº	Description
1	WC-58223	PANEL, LEFT SIDE EXPR
2	WC-58232	DOOR, COMPLETE
3	CA-1143	FILM, GENERIC EXPR
4	CA-1127 *	LAMP COMPLETE, W/5K BULB
5	WC-37298*	KIT, UCM & SMART CARD & OVERLAY
6	WC-39608	LABEL, UCM PANEL
7	CA-1098-102	COVER, ALCOVE PLASTIC EXPR
8	WC-8591 *	CAPACITOR, X2 ALL ADS MODELS
9	WC- 796	CONTROL, POWER MODULE (NOT SHOWN)
10	WC-37123	FAN, EXTRACT (NOT SHOWN)
11*	CA-1039*	O-RING, DUMP VLV WC-880E (NOT SHOWN)
12	WC-37008	KIT, TANK LID ROUND
13	WC-37278*	KIT, WATER LEVEL PROBE
14	WC-3734 *	KIT, RPL DUMP VALVE FOR WC-880E
15	WC- 917-04*	HEATING ELEMENT, 1.45KW W/JAMNUTS
16	WC-1438-101*	SENSOR, TEMPERATURE TANK
17	WC- 523 *	THERMOSTAT, MNL RESET 120/240V 25A
18	WC- 102 *	SWITCH, TOGGLE NON LIT 25A 120/240V
19	CA-1100-101	COVER, DRIP TRAY PLASTIC PCGT-3
20	CA-1099-101	DRIP TRAY, PLASTIC PCGT-3
21	WC-68131-101	SCREEN, DRIP TRAY PCGT3
22	CA-1142-06	CANISTER, ASSY ULTRA SLIM
22A	CA-1113-06R	CANISTER ASSY, 10LB RIGHT PCGTs
23	CA-1011-05	FITTING, BULKHEAD WATER
24	CA-1095	CONNECTOR, ORIFICE WATER PCGT
25	CA-1026-03	ELBOW, PC/CK/HC
25A	CA-1026-06	ELBOW, CANISTER RIGHT
25B	CA-1026-07	ELBOW, CANISTER LEFT
26	CA-1005-03 *	STEAM TRAP
27	CA-1009-03 *	BOWL, MIXING
28	CA-1152 *	MANIFOLD 3 IN 1 BARISTA
29	CA-1142	LID, CANISTER, ULTRA SLIM

Item Nº	Part Nº	Description
29A	WC-5664-05	LID, CANISTER, 10LB PCGT's
30	WC-66047	ADAPTOR, EXTRTR FAN HOSE (NOT SHWN)
31	WC-37054	KIT, SOCKET GEAR PC/CK/HC
32	WC-58229	EXTENSION, GEAR MOTOR SHAFT
33	WC-3739 *	MOTOR, WHIPPER
34	WC-43791 *	RING, MOTOR SHAFT PLASTIC
35	WC-37118 *	KIT, WHIPPER PLATE (W/SEAL) 3/PKG
36	CA-1008-07K *	KIT, PROPLR OFFSET BLADES PCGT PKG6
37	CA-1006-06 *	WHIPPER CHAMBER
38	CA-1024-05	PILLAR, LOCATION BLACK
39	WC-37174 *	KIT, GEAR MOTOR, CORK BRAKE PCGT
40	CA-1036 *	GEAR, PLASTIC USE ON CA-1013's
41	WC-3765L *	KIT, INLET VALVE REPAIR USE ON WC-826L
42	WC-5231 *	COMPOUND, SILICONE 5 OZ TUBE
43	WC-38460	LABEL, CLEAN ENG/SPNSH (NOT SHOWN)
44	WC- 826L *	VALVE, INLET
45	WC-8556 *	HEAT SINK ASSEMBLY (NOT SHOWN)
46	WC-5310 *	TUBE, 5/16" ID X 1/8" W SILICONE
47	CA-1030-23	HOSE, EXTRACTOR FAN 23" LONG
48	WC-62043	HEATING TANK, COMPLETE EXPR
49	WC-58121	COVER, DUMP VALVE PC-3GT
50	WC-58228	CANISTER TRAY, ASSY
51	CA-1123	LAMP, 30W 5K CIRCULAR
52	CA-1135	LATCH ASSY, DOOR SIDE MOUNT
53	WC-3503	LEG, 3/8"-16 STD SCREW BUMPER
54	WC-3518	LEG, GUIDE 3/8"-16 STUD SCREW
55	WC-4320	O-RING, 1/2" I.D. (NOT SHOWN)
56	WC-4394	GUARD, SHOCK HEATING ELEMENT
57	WC-3689	INSULATION, WRAP PCGT
58	WC-58224	PANEL, RIGHT SIDE
59	WC-2627	BUSHING, CONICAL .583 ID x .945 OD x .945 L

* Suggested Parts to Stock

Illustrated Parts List – Detail Bubbles

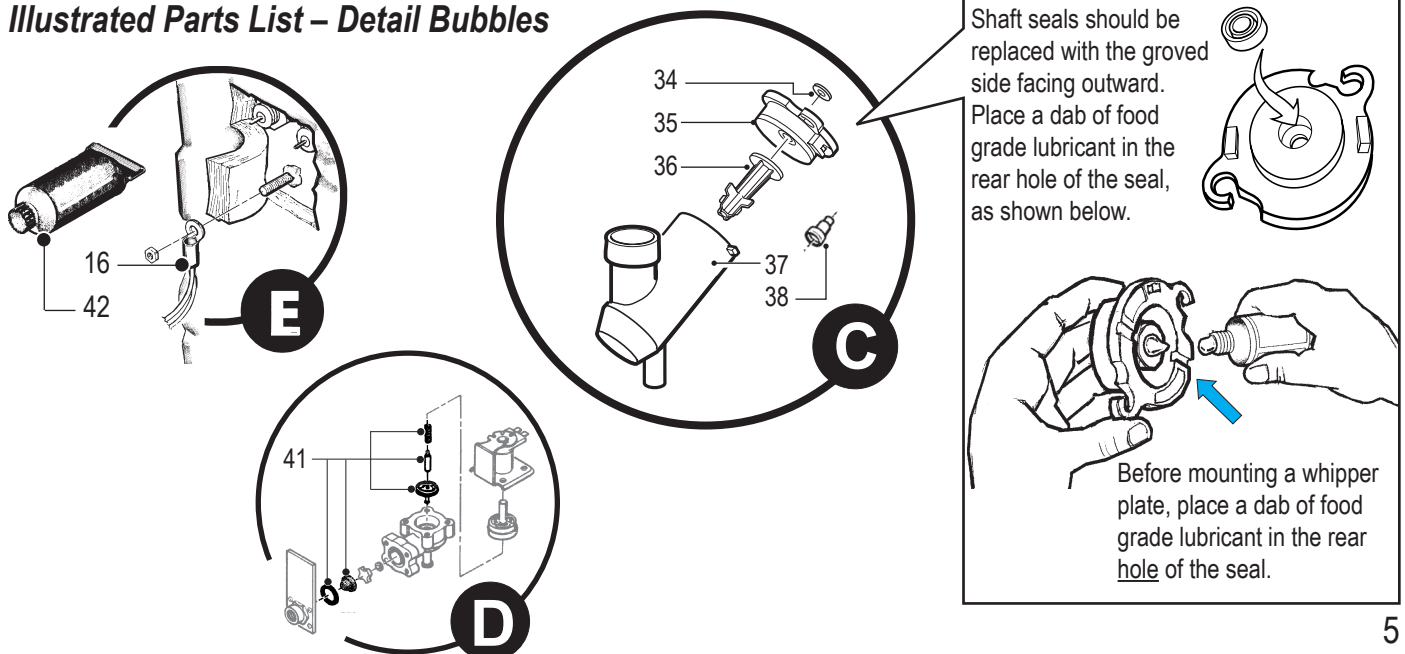

Illustrated Parts List

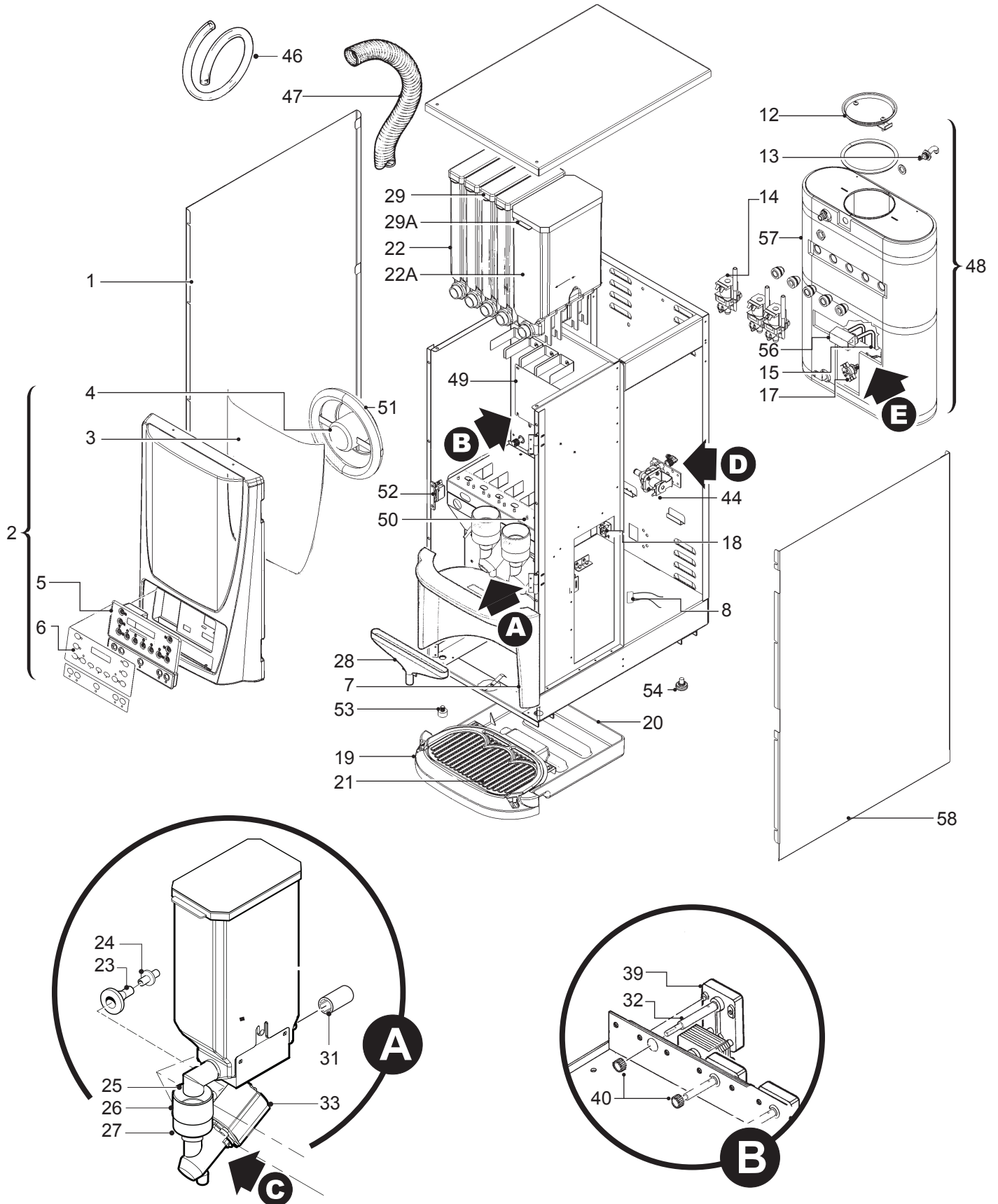

Electrical Diagram

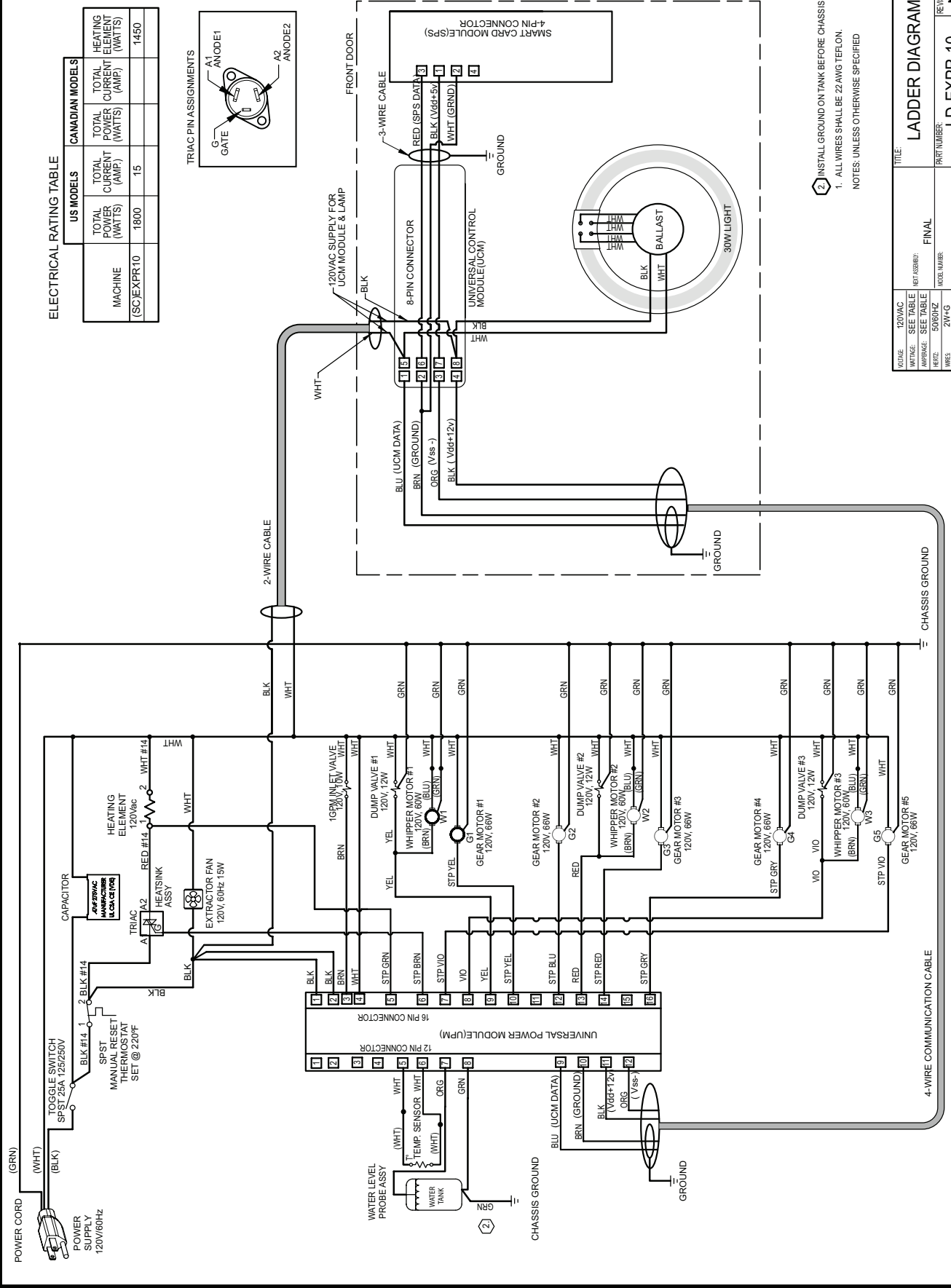

ELECTRICAL RATING TABLE

MACHINE	US MODELS		CANADIAN MODELS	
	TOTAL POWER (WATTS)	TOTAL CURRENT (AMP)	TOTAL POWER (WATTS)	TOTAL CURRENT (AMP)
(SC)EXPR10	1800	15		
			TOTAL HEATING ELEMENT (WATTS)	1450

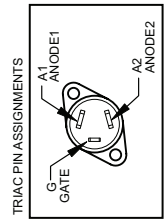

- INSTALL GROUND ON TANK BEFORE CHASSIS.
 - ALL WIRES SHALL BE 22 AWG TEFLON.
- NOTES: UNLESS OTHERWISE SPECIFIED

REVISE	120VAC	10/1/2007	FINAL	TITLE	LADDER DIAGRAM
WIRING	SEE TABLE			REV/ISSN	NC
APPROVE	SEE TABLE			PART NUMBER	LD-EXPR-10
DATE	5/30/2012			MODEL NUMBER	
WKS	ZHWG			SEE ELECTRICAL TABLE	
PAGE	1/1				

Product Warranty Information

The Wilbur Curtis Company certifies that its products are free from defects in material and workmanship under normal use. The following limited warranties and conditions apply:

- 3 Years, Parts and Labor, from Original Date of Purchase on digital control boards.
- 2 Years, Parts, from Original Date of Purchase on all other electrical components, fittings and tubing.
- 1 Year, Labor, from Original Date of Purchase on all electrical components, fittings and tubing.

Additionally, the Wilbur Curtis Company warrants its Grinding Burrs for Forty (40) months from date of purchase or 40,000 pounds of coffee, whichever comes first. Stainless Steel components are warranted for two (2) years from date of purchase against leaking or pitting and replacement parts are warranted for ninety (90) days from date of purchase or for the remainder of the limited warranty period of the equipment in which the component is installed.

All in-warranty service calls must have prior authorization. For Authorization, call the Technical Support Department at 1-800-995-0417. Effective date of this policy is April 1, 2003.

Additional conditions may apply. Go to www.wilburcurtis.com to view the full product warranty information.

CONDITIONS & EXCEPTIONS

The warranty covers original equipment at time of purchase only. The Wilbur Curtis Company, Inc., assumes no responsibility for substitute replacement parts installed on Curtis equipment that have not been purchased from the Wilbur Curtis Company, Inc. The Wilbur Curtis Company will not accept any responsibility if the following conditions are not met. The warranty does not cover and is void under the following circumstances:

- 1) **Improper operation of equipment:** *The equipment must be used for its designed and intended purpose and function.*
- 2) **Improper installation of equipment:** *This equipment must be installed by a professional technician and must comply with all local electrical, mechanical and plumbing codes.*
- 3) **Improper voltage:** *Equipment must be installed at the voltage stated on the serial plate supplied with this equipment.*
- 4) **Improper water supply:** *This includes, but is not limited to, excessive or low water pressure, and inadequate or fluctuating water flow rate.*
- 5) **Adjustments and cleaning:** *The resetting of safety thermostats and circuit breakers, programming and temperature adjustments are the responsibility of the equipment owner. The owner is responsible for proper cleaning and regular maintenance of this equipment.*
- 6) **Damaged in transit:** *Equipment damaged in transit is the responsibility of the freight company and a claim should be made with the carrier.*
- 7) **Abuse or neglect (including failure to periodically clean or remove lime accumulations):** *Manufacturer is not responsible for variation in equipment operation due to excessive lime or local water conditions. The equipment must be maintained according to the manufacturer's recommendations.*
- 8) **Replacement of items subject to normal use and wear:** *This shall include, but is not limited to, light bulbs, shear disks, "O" rings, gaskets, silicone tube, canister assemblies, whipper chambers and plates, mixing bowls, agitation assemblies and whipper propellers.*
- 9) **Repairs and/or Replacements** *are subject to our decision that the workmanship or parts were faulty and the defects showed up under normal use. All labor shall be performed during regular working hours. Overtime charges are the responsibility of the owner. Charges incurred by delays, waiting time, or operating restrictions that hinder the service technician's ability to perform service is the responsibility of the owner of the equipment. This includes institutional and correctional facilities. The Wilbur Curtis Company will allow up to 100 miles, round trip, per in-warranty service call.*

RETURN MERCHANDISE AUTHORIZATION: *All claims under this warranty must be submitted to the Wilbur Curtis Company Technical Support Department prior to performing any repair work or return of this equipment to the factory. All returned equipment must be repackaged properly in the original carton. No units will be accepted if they are damaged in transit due to improper packaging. **NO UNITS OR PARTS WILL BE ACCEPTED WITHOUT A RETURN MERCHANDISE AUTHORIZATION (RMA). RMA NUMBER MUST BE MARKED ON THE CARTON OR SHIPPING LABEL.** All in-warranty service calls must be performed by an authorized service agent. Call the Wilbur Curtis Technical Support Department to find an agent near you.*



WILBUR CURTIS CO., INC.

6913 Acco St., Montebello, CA 90640-5403 USA

Phone: 800/421-6150 ♦ Fax: 323-837-2410

♦ Technical Support Phone: 800/995-0417 (M-F 5:30A - 4:00P PST) ♦ E-Mail: techsupport@wilburcurtis.com

♦ Web Site: www.wilburcurtis.com

FOR THE LATEST SPECIFICATION INFORMATION GO TO WWW.WILBURCURTIS.COM