



# G3 Series Alpha<sup>®</sup> Decanter Coffee Brewing System



ALPHA3GT Shown

## READ AND SAVE THESE INSTRUCTIONS

**NOTICE TO INSTALLER:** Please leave this booklet with the machine.

Key Features/Specifications/System Requirements..... FS33

Important Safeguards..... IS2

Important Safeguards (EC Directives)..... IS15

Installation Instructions (General)..... II2

Installation Instructions (Leveling, Water Supply, Electrical)..... II18

Operating Instructions ..... OI25

Cleaning Instructions (Brewer) ..... CI1

Cleaning Instructions (Decanters) ..... CI11

Programming Guide ..... PG9

Rough-In Drawing, ALPHA® 1/2/3GT..... RD38

Rough-In Drawing, ALPHA 3GTL/3GTR/5GT/6GT/6GTN..... RD39

Illustrated Parts/Recommended Parts (Main Chassis)..... IP61

Illustrated Parts/Recommended Parts (Tank Assembly, 120 Volt)..... IP57

Illustrated Parts/Recommended Parts (Tank Assembly, 120/220 Volt)..... IP58

Illustrated Parts/Recommended Parts (Tank Assembly, 220-240 Volt) ..... IP59

Electrical Schematic (120 Volt)..... ES63

Electrical Schematic (Dual Voltage, ALPHA1GT/2GT/3GT/5GT) ..... ES64

Electrical Schematic (Dual Voltage, ALPHA6GTN)..... ES65

Electrical Schematic (220-240 Volt, 2500/3500 Watt) ..... ES66

Electrical Schematic (220-240 Volt, 2000 Watt) ..... ES146

Troubleshooting Guide (General) ..... TG5

Troubleshooting Guide (Triac Circuit)..... TG39

Troubleshooting Guide (Warmer Circuit)..... TG14

Error Codes ..... EC4

Product Warranty..... PW1

**Contact Information**

**Wilbur Curtis Co., Inc.**

6913 Acco Street | Montebello, CA 90640 US  
 Phone: 323-837-2300 | Toll Free: 800-421-6150  
 Email: [csrcassistance@wilburcurtis.com](mailto:csrcassistance@wilburcurtis.com) | Web: [www.wilburcurtis.com](http://www.wilburcurtis.com)

For the latest specifications and information go to [www.wilburcurtis.com](http://www.wilburcurtis.com)  
 Toll Free: 800-995-0417 | Monday - Friday 5:30 A.M. - 4:00 P.M. PT  
 Email: [techsupport@wilburcurtis.com](mailto:techsupport@wilburcurtis.com)

Due to continued product improvement, the products illustrated/photographed in this guide may vary slightly from the actual product.

## Key Features

- Digital Control Module - Provides precise control over all aspects of brewing: time, temperature, volume plus specialty coffee needs from pre-infusion to pulse-brewing to water bypass.
- Factory Set – For out-of-the-box operation.
- Intuitive Scroll-Through Precision Programming – Large, brightly lighted display communicates functions at a glance. Easily adjust time, volume, temperature, brew functions and more.
- Tamper Resistant – Changeable access code prevents unauthorized adjustment.

## Specifications (Selected Single Models)

### Electrical Supply Requirements

MODEL #	DESCRIPTION	PHASE	VOLTS	AMPS	HEATING CONFIG	WIRE	WATTS	HERTZ	CAPACITY
ALP1GT12A000	1 Lower Warmer	1 PH	120 V	13.3 A	1 x 1450 W	2W + G	1600 W	50/60 Hz	4.0 gal/hr [15.1 l/hr]
ALP2GT12A000	1 Lower, 1 Upper Warmer	1 PH	120 V	14.2 A	1 x 1450 W	2W + G	1700 W	50/60 Hz	4.0 gal/hr [15.1 l/hr]
ALP2GT32A000	1 Lower, 1 Upper Warmer	1 PH	230 V	13.7 A	1 x 2500 W	2W + G	3153 W	50/60 Hz	7.0 gal/hr [26.5 l/hr]
ALP2GT34x	1 Lower, 1 Upper Warmer	1 PH	220-240 V	10.1-11.0 A	1 x 2000 W	2W + G (1/N/PE)	2225-2648 W	50/60 Hz	4.0 gal/hr [15.1 l/hr]
ALP3GT12A000	1 Lower, 2 Upper Warmers	1 PH	120 V	15.0 A	1 x 1450 W	2W + G	1800 W	50/60 Hz	4.0 gal/hr [15.1 l/hr]
ALP3GT32A000	1 Lower, 2 Upper Warmers	1 PH	230 V	14.2 A	1 x 2500 W	2W + G	3263 W	50/60 Hz	7.0 gal/hr [26.5 l/hr]
ALP3GT63A000	Dual voltage, 1 Lower, 2 Upper Warmers	1 PH	120/220 V	15.0/15.0 A	2 x 1450 W	2W/3W + G	1800/3300 W	50/60 Hz	4.0/9.0 gal/hr [15.1/34.1 l/hr]
ALP3GTL12A000/ ALP3GTR12A000	3 Lower Warmers, 2 on Left/Right	1 PH	120 V	15.0 A	1 x 1450 W	2W + G	1800 W	50/60 Hz	4.0 gal/hr [15.1 l/hr]
ALP3GTL63A000/ ALP3GTR63A000	Dual voltage, 3 Lower Warmers, 2 on Left/Right	1 PH	120/220 V	15.0/15.0 A	2 x 1450 W	2W/3W + G	1800/3300 W	50/60 Hz	4.0/9.0 gal/hr [15.1/34.1 l/hr]

### Dimensions

### Water Supply Requirements

MODEL #	HEIGHT	WIDTH	DEPTH	SHIP WEIGHT	SHIP CUBE	WATER CONNECTOR	WATER PRESSURE	MIN. FLOW RATE
ALP1GT12A000	17.13" [43.5 cm]	9.13" [23.2 cm]	20.25" [51.4 cm]	29.0 lbs [13.2 kg]	3.92 cu. ft. [0.11 m <sup>3</sup> ]	1/4" flare	20 - 90 psi [138 - 620 kPa]	1.0 gpm [3.8 lpm]
ALP2GT12A000	17.63" [44.8 cm]	9.13" [23.2 cm]	20.25" [51.4 cm]	30.0 lbs [13.6 kg]	3.92 cu. ft. [0.11 m <sup>3</sup> ]	1/4" flare	20 - 90 psi [138 - 620 kPa]	1.0 gpm [3.8 lpm]
ALP2GT32A000	17.63" [44.8 cm]	9.13" [23.2 cm]	20.25" [51.4 cm]	30.0 lbs [13.6 kg]	3.92 cu. ft. [0.11 m <sup>3</sup> ]	1/4" flare	20 - 90 psi [138 - 620 kPa]	1.0 gpm [3.8 lpm]
ALP2GT34x	17.63" [44.8 cm]	9.13" [23.2 cm]	20.25" [51.4 cm]	30.0 lbs [13.6 kg]	3.92 cu. ft. [0.11 m <sup>3</sup> ]	1/4" flare	20 - 90 psi [138 - 620 kPa]	1.0 gpm [3.8 lpm]
ALP3GT12A000	19.13" [48.6 cm]	9.13" [23.2 cm]	20.25" [51.4 cm]	31.0 lbs [14.1 kg]	3.92 cu. ft. [0.11 m <sup>3</sup> ]	1/4" flare	20 - 90 psi [138 - 620 kPa]	1.0 gpm [3.8 lpm]
ALP3GT32A000	19.13" [48.6 cm]	9.13" [23.2 cm]	20.25" [51.4 cm]	31.0 lbs [14.1 kg]	3.92 cu. ft. [0.11 m <sup>3</sup> ]	1/4" flare	20 - 90 psi [138 - 620 kPa]	1.0 gpm [3.8 lpm]
ALP3GT63A000	19.13" [48.6 cm]	9.13" [23.2 cm]	20.25" [51.4 cm]	31.0 lbs [14.1 kg]	3.92 cu. ft. [0.11 m <sup>3</sup> ]	1/4" flare	20 - 90 psi [138 - 620 kPa]	1.0 gpm [3.8 lpm]
ALP3GTL12A000/ ALP3GTR12A000	17.18" [43.6 cm]	15.84" [40.2 cm]	20.38" [51.8 cm]	38.0 lbs [17.2 kg]	6.70 cu. ft. [0.19 m <sup>3</sup> ]	1/4" flare	20 - 90 psi [138 - 620 kPa]	1.0 gpm [3.8 lpm]
ALP3GTL63A000/ ALP3GTR63A000	17.18" [43.6 cm]	15.84" [40.2 cm]	20.38" [51.8 cm]	38.0 lbs [17.2 kg]	6.70 cu. ft. [0.19 m <sup>3</sup> ]	1/4" flare	20 - 90 psi [138 - 620 kPa]	1.0 gpm [3.8 lpm]

continued...

## Specifications (Selected Single Multi-Warmer and Twin Models)

### Electrical Supply Requirements

MODEL #	DESCRIPTION	PHASE	VOLTS	AMPS	HEATING CONFIG	WIRE	WATTS	HERTZ	CAPACITY
ALP5GT12A000	5 Station, 5 lower, Right/Left Warmers	1 PH	120 V	16.3 A	1 x 1450 W	2W + G	1950 W	50/60 Hz	4.0 gal/hr [15.1 l/hr]
ALP5GT63A000	Dual voltage, 5 Lower, Right/Left Warmers	1 PH	120/220 V	16.3/15.9 A	2 x 1450 W	2W/3W + G	1950/4500 W	50/60 Hz	4.0/9.0 gal/hr [15.1/34.1 l/hr]
ALP6GT63A000	Dual voltage, Twin, 6 Lower Warmers	1 PH	120/220 V	30.0/30.0 A	2 x 1450 W	2W/3W + G	3600/6600 W	50/60 Hz	4.0/9.0 gal/hr [15.1/34.1 l/hr]
ALP6GTN63A000	Dual voltage, Twin, 4 Upper, 2 Lower Warmers	1 PH	120/220 V	30.0/30.0 A	2 x 1450 W	2W/3W + G	3600/6600 W	50/60 Hz	4.0/9.0 gal/hr [15.1/34.1 l/hr]

### Dimensions

### Water Supply Requirements

MODEL #	HEIGHT	WIDTH	DEPTH	SHIP WEIGHT	SHIP CUBE	WATER CONNECTOR	WATER PRESSURE	MIN. FLOW RATE
ALP5GT12A000	17.18" [43.6 cm]	22.56" [57.3 cm]	20.38" [51.8 cm]	44.0 lbs [20.0 kg]	8.20 cu. ft. [0.23 m <sup>3</sup> ]	1/4" flare	20 - 90 psi [138 - 620 kPa]	1.0 gpm [3.8 lpm]
ALP5GT63A000	17.18" [43.6 cm]	22.56" [57.3 cm]	20.38" [51.8 cm]	45.0 lbs [20.4 kg]	8.20 cu. ft. [0.23 m <sup>3</sup> ]	1/4" flare	20 - 90 psi [138 - 620 kPa]	1.0 gpm [3.8 lpm]
ALP6GT63A000	17.18" [43.6 cm]	31.58" [80.2 cm]	20.38" [51.8 cm]	72.0 lbs [32.7 kg]	11.61 cu. ft. [0.33 m <sup>3</sup> ]	1/4" flare	20 - 90 psi [138 - 620 kPa]	1.0 gpm [3.8 lpm]
ALP6GTN63A000	19.13" [48.6 cm]	18.00" [45.7 cm]	20.25" [51.4 cm]	60.0 lbs [27.2 kg]	8.67 cu. ft. [0.25 m <sup>3</sup> ]	1/4" flare	20 - 90 psi [138 - 620 kPa]	1.0 gpm [3.8 lpm]

Following are the factory default settings for the Alpha® brewer:

- Brew Temperature = 200°F (92°C)
- Brew Volume = 60oz. (1.8L)
- Energy Save Mode = Off

**Symbols**



This is the safety alert symbol. It is used to alert you to potential physical injury hazards. Obey all safety messages that follow this symbol to avoid possible injury or death.



**DANGER** - Indicates a hazardous situation which, if not avoided, will result in death or serious injury.



**WARNING** - Indicates a hazardous situation which, if not avoided, could result in death or serious injury.



**CAUTION** - Indicates a hazardous situation which, if not avoided, could result in minor or moderate injury.



**NOTICE** - Indicates a situation which, if not avoided, could result in property damage.



**IMPORTANT** - Provides information and tips for proper operation.



**SANITATION REQUIREMENTS**



**WARNING** - This product can expose you to chemicals including Acrylamide and Bisphenol A (BPA), which are known to the State of California to cause cancer and birth defects or other reproductive harm. For more information visit [www.P65Warnings.ca.gov](http://www.P65Warnings.ca.gov).

**Important Safeguards/Conventions**



**WARNING:**

- Make sure that this appliance is installed and grounded according to the INSTALLATION INSTRUCTIONS by qualified personnel before attempting to use it. Failure to follow the INSTALLATION INSTRUCTIONS could result in personal injury or void the warranty.
- This appliance is designed for commercial use. Any service other than cleaning and preventive maintenance should be performed by an authorized Wilbur Curtis service technician.
- To reduce the risk of fire or electric shock, DO NOT open the service panels. There are no user serviceable parts inside.
- Keep hands, arms and other items away from hot surfaces of the unit during operation.
- Clean the appliance and any dispensers completely before using them for the first time according to the CLEANING INSTRUCTIONS. Clean them regularly as instructed in the CLEANING INSTRUCTIONS.
- Use this appliance only for its intended use, brewing/dispensing hot and/or cold beverages/water.
- This appliance is not intended for use by persons (including children) with reduced physical, sensory or mental capabilities or lack of experience and knowledge, unless they have been given supervision or instruction concerning use of the appliance by a person responsible for their safety. Children should be supervised to ensure that they do not play with the appliance.
- Avoid spillage onto the power (mains) connector.

## CE Requirements

- This appliance must be installed in locations where it can be overseen by trained personnel.
- For proper operation, this appliance must be installed where the temperature is between 5°C to 35°C.
- This appliance is not suitable for outdoor use.
- This appliance shall not be tilted more than 10° for safe operation.
- An electrician must provide electrical service as specified in conformance with all local and national codes. For safe use, an all-pole disconnection must be incorporated into the fixed wiring in accordance with the wiring rules outlined in clause 7.12.2 of IEC 60335 for meeting the minimum electrical safety of this standard.
- This appliance must not be cleaned by water jet.
- This appliance can be used by persons aged from 18 years and above if they have been given supervision or instruction concerning use of the appliance in a safe way and if they understand the hazards involved.
- Keep the appliance and its cord out of reach of children aged less than 18 years.
- Appliances can be used by persons 18 years and above with reduced physical, sensory or mental capabilities or lack of experience and knowledge if they have been given supervision or instruction concerning use of the appliance in a safe way and understand the hazards involved.
- Children under the age of 18 years should be supervised to ensure they do not play with the appliance.
- If the power cord is ever damaged, it must be replaced by the manufacturer or authorized service personnel with a special cord available from the manufacturer or its authorized service personnel in order to avoid a hazard.
- Machine must not be immersed for cleaning.
- Cleaning and user maintenance shall not be made by children unless they are older than 18 years and supervised.
- This appliance is intended to be used in household and similar applications such as:
  - staff kitchen areas in shops, offices and other working environments;
  - by clients in hotels, motels and other residential type environments;
  - bed and breakfast type environments.
- This appliance not intended to be used in applications such as:
  - farm houses
- Access to the service areas permitted by Authorized Service personnel only.
- The A-Weighted sound pressure level is below 70 dBA.

## Disposal of Equipment

- This product contains plastic, metal and electronic components and is considered e-waste. At the end of its life, this product must not be disposed of in normal household waste but can be instead delivered to a collection point for recycling electric and electronic appliances, consult with the local municipality for proper disposal guidelines.

### European Regulations and Directives

- This appliance meets the requirements of all applicable regulations in Regulation 1907/2006/EU (REACH), Directive 2011/65/EU (ROHS) and its amendment (EU) 2015/863, Directive 2012/19/EU (WEEE), Directive 2014/30/EU (EMC), Directive 2006/42/EC (Machinery) and Directive 2014/35/EU (LVD).
- The declaration of conformity is included with this appliance. The appliance bears the CE mark.
- This appliance is subject to the directive on waste electrical and electronic equipment (WEEE/ EU directive). Do not dispose of this appliance in domestic waste. Contact your local governing authorities for information on disposal requirements.
- Any modifications to equipment that are not approved by the Wilbur Curtis Company will render this declaration invalid.





**WARNING:** Installation is to be performed only by a qualified installer.



**WARNING:** Improper electrical connection may result in an electric shock hazard or damage the unit. This appliance must be properly grounded.



**NOTICE:** DO NOT connect this appliance to a hot water supply. The water inlet valve is not rated for hot water. Do not exceed the maximum water pressure stated in the **SPECIFICATIONS** section.



**IMPORTANT:** Observe all governing codes and ordinances.

## Installation Instructions

### Installation Requirements

- A secure surface capable of supporting the weight of the appliance.
- For units without an attached cord set attached or dual voltage units set up for use with 220 - 240 Volts: Appropriately sized, UL listed, grounding type power cable to meet the electrical specifications for the appliance. If you have questions about the correct cable size and length, consult a qualified installer. If the appliance will be hard wired to a junction box, the power cable must be long enough so that the unit can be moved for cleaning underneath.
- A grounded electrical connection to an electrical circuit that meets the electrical specifications of the appliance (see **SPECIFICATIONS**). The circuit must be protected by the appropriate sized circuit breaker. If you are not certain that the existing circuit meets the requirements for your unit, consult a licensed electrician.
- A water filtration system is required to maintain trouble-free operation. Wilbur Curtis Co., Inc. recommends a Wilbur Curtis approved water filter. See the Curtis Equipment Catalog for a full line of Wilbur Curtis approved water filters.
- Potable water supply line connection from the water filter capable of supplying the minimum flow rate required by the specifications. The water supply line must be able to connect to the flare fitting on the back of the unit. See the **SPECIFICATIONS** section for the correct size. The water line should also be capable of being controlled by a shut off valve. Do not connect the water line to a saddle valve or needle valve.

IEC requires the following water connection:

- 1 A quick disconnect or additional coiled tubing (at least two times the depth of the appliance) is required so that it can be moved for cleaning underneath.
- 2 This equipment is to be installed with adequate back-flow protection to comply with applicable federal, state and local codes.
- 3 Water pipe connections and fixtures directly connected to a potable water supply shall be sized, installed and maintained in accordance with federal, state and local codes.

The International Plumbing Code of the International Code Council and the Food and Drug Administration (FDA) Food Code manual, direct that this equipment must be installed with adequate back-flow prevention in compliance with federal, state and local codes. For units installed outside of the U.S.A., make sure that the installation is in compliance with the applicable plumbing/sanitation code for your area.

Installation

Leveling

**WARNING:** Use the leveling legs to level the brewer only. Do not use them to adjust brewer height. Do not extend them higher than necessary.

Position the brewer on the countertop. Level it left to right and front to back by turning the bottom of the legs.

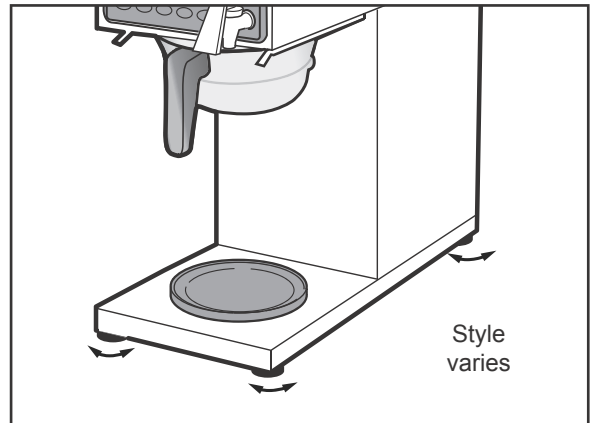

**Setting Up Dual Voltage Units for 220-240 Volt Operation**  
(See *SPECIFICATIONS* for a list of model numbers)

**WARNING:** Do not connect the power cord to the power supply until instructed to do so.

1 Remove the back cover.

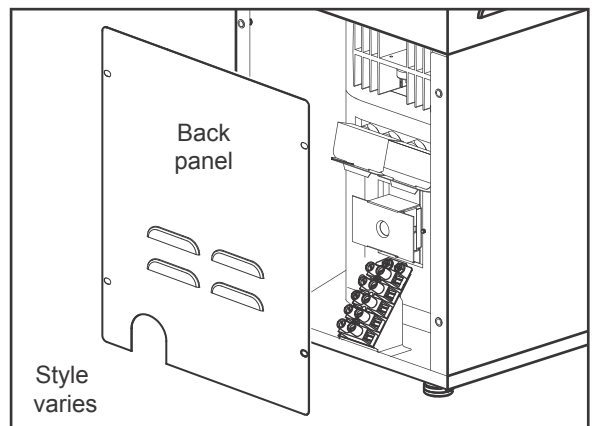

2 Loosen the strain relief on the back of the brewer.

3 Disconnect the existing power cord from the terminal block and remove it.

4 Disconnect and cap the jumper wire between the “C” and “N” terminals on the terminal block.

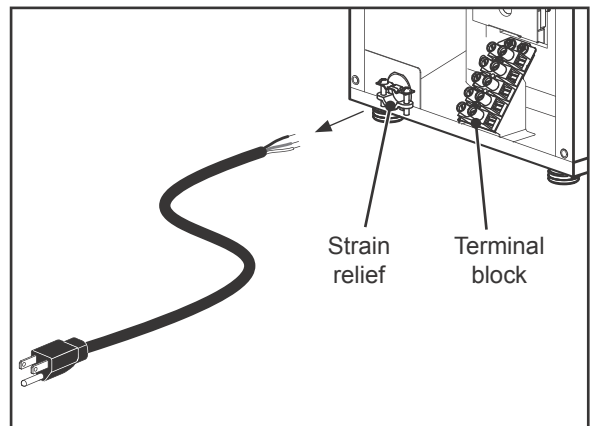

5 Feed the 220-240 Volt power cable through the strain relief, into the brewer. The brewer may be wired for connection directly to a junction box (if local ordinances permit) or for use with a power plug that connects to an electrical outlet meeting the brewer *SPECIFICATIONS*.

6 Connect the wires on the power cable to the terminal block inside the brewer according to the *ELECTRICAL SCHEMATIC*.

7 Tighten the strain relief and replace the back cover.

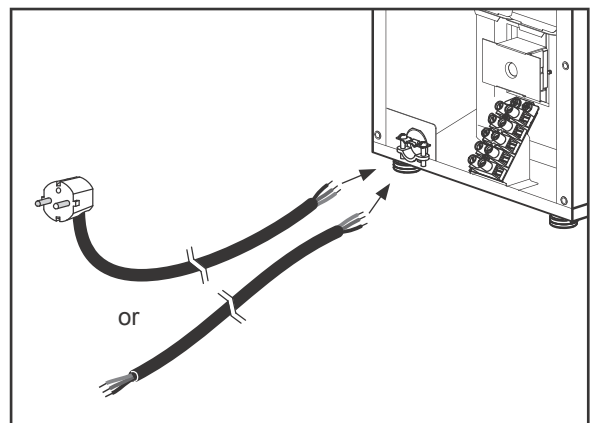

continued...

**Connecting the Brewer Wiring - Single Brewers That Come from the Factory Without a Power Cord Attached**

**WARNING:** Do not connect the power cord to the power supply until instructed to do so.

Brewers With Power Connector Mounted to the Back Panel

Connect a C20 IEC power cord (not supplied) compatible with the electrical outlet installed in the facility and that meets specifications.

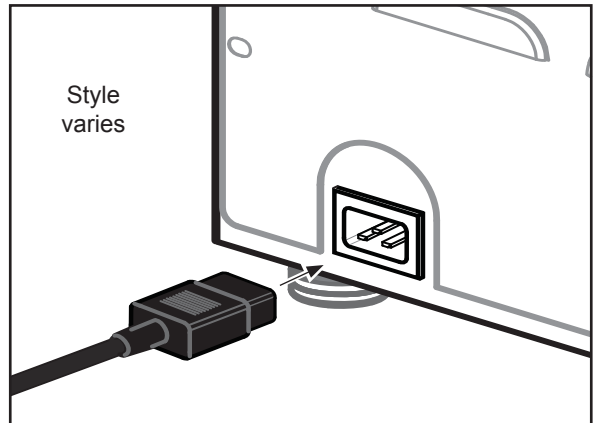

Brewers With Strain Relief Mounted to the Back Panel

- 1 Remove the back cover.
- 2 Loosen the strain relief on the back of the brewer.
- 3 Feed the power cable into the brewer. The brewer may be wired for connection directly to a junction box (if local ordinances permit) or for use with a power plug that connects to an electrical outlet meeting the brewer **SPECIFICATIONS**.
- 4 Connect the wires on the power cable to the terminal block inside the brewer as specified. See the **ELECTRICAL SCHEMATIC**.
- 5 Tighten the strain relief and replace the back cover.

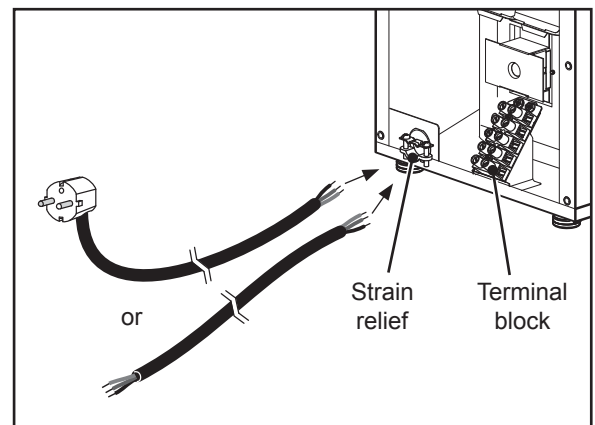
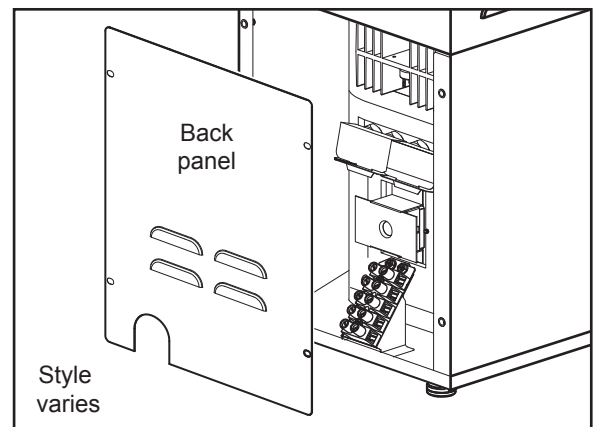

continued...

**Connecting the Brewer Wiring - Twin Brewers**

**WARNING:** Do not connect the power cord to the power supply until instructed to do so.

- 1 Remove the back cover.
- 2 Loosen the strain relief on the back of the brewer.

Brewers Operated with 220-240 Volts

- Feed the 220-240 Volt power cable into the brewer.
- Connect the wires on the power cable to the left terminal block inside the brewer.
- Skip to step 3.

Brewers Operated on 120 Volts

Two 120 Volt power cables (not supplied) are required to connect the twin brewer for use with a 120 Volt power supply. See the **ELECTRICAL SCHEMATIC** for the power supply requirements.

- Remove the four jumper wires connected between the left and right terminal blocks inside the brewer. Be sure to tighten the other existing wires back into place. Keep the jumper wires in the event that the brewer needs to be converted back to 220-240 Volt operation.
- On both terminal blocks, uncap the white wire connected to the “N” terminal and connect the bare wire to the “C” terminal.
- Feed the 120 Volt power cords through the strain relief, into the brewer.
- Connect one power cord to the left terminal block and one to the right terminal block.

- 3 Tighten the strain relief and replace the back cover.

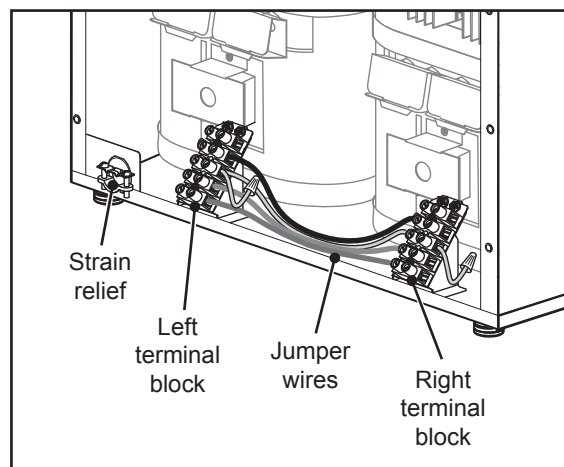
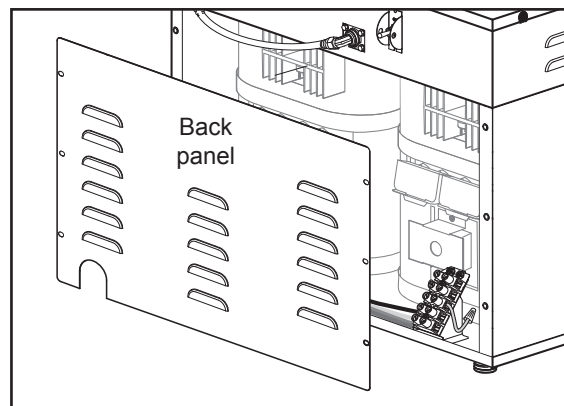

**Connecting the Water Supply**

- 1 Flush the water supply line prior to installation to purge air and debris from the water filter and tubing.
- 2 Connect the water supply line to the flare fitting on the back of the brewer. Leave the water supply valve closed until the power is connected.

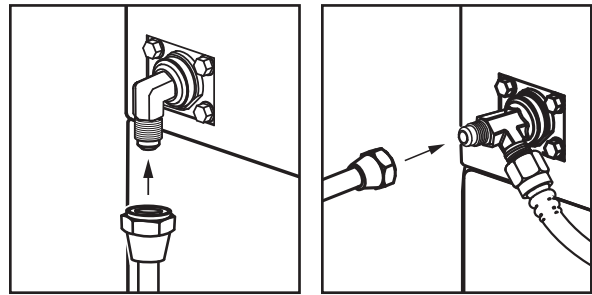

**Electrical Connection**

Connection to a Junction Box



**WARNING:** Turn off power to the junction box at the circuit breaker panel and lock out and tag the circuit breaker before connecting the power cable to the junction box.

- 3 Connect the power cable wires to the terminals in the junction box and replace the cover. See the *ELECTRICAL SCHEMATIC* for the power supply requirements.

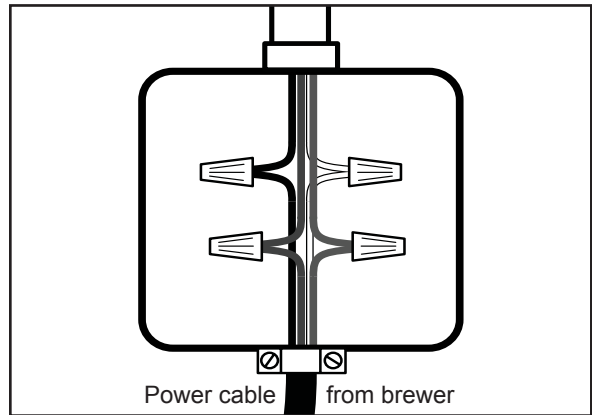

Connection to an Electrical Outlet



**WARNING:** Connect the power cord only to the appropriate type and size electrical outlet. If it is not compatible, either have the cord replaced or have the electrical outlet upgraded by a licensed electrician. Do not use an extension cord. Do not use a power cord/plug that is damaged..

- 4 If not already installed, install the appropriate type of power plug for your locality. Consult local electrical codes to determine the approved type of power plug for your region.
- 5 Connect the power plug to the appropriate electrical outlet.

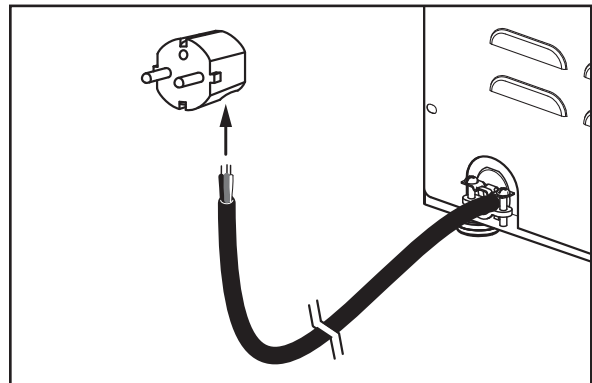

**Powering Up the Brewer**

- 6 Turn on the water supply valve.
- 7 Make sure that the circuit breaker supplying power to the brewer is on.
- 8 Turn the toggle switch on the back of the brewer to the ON position. Twin brewers have two switches, one for each side. The water tank(s) will start to fill. While filling, inspect the water supply line for leaks.

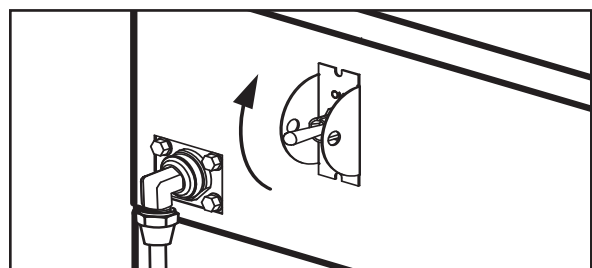
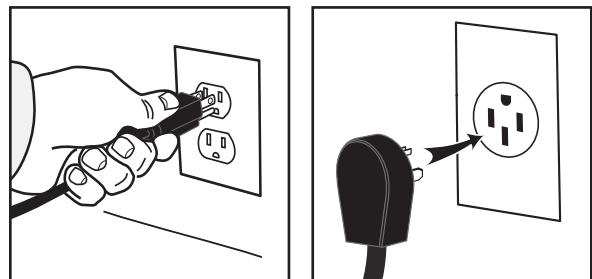

continued...

**Powering Up the Brewer (cont.)**

- 9 When the water in the tank rises to the correct level, the heating elements will turn on automatically. Depending on the incoming water temperature and the electrical specifications, the water tank typically requires 20 to 30 minutes to reach the factory set operating temperature. When the water has heated, **Ready to brew** will be displayed on the LCD screen.

---

**i** **IMPORTANT:** When operating the brewer at higher elevations, reduce the factory set operating temperature (200°F/92°C) by 2°F/1°C for each 1000 ft./300 m of elevation above 4000 ft./1200 m. See the *PROGRAMMING GUIDE* section.

---

- 10 Perform a brew cycle of a least 12 oz./350 ml to purge any remaining air from the system. See *OPERATING INSTRUCTIONS*. On twin units, perform a brew cycle on both sides. During the initial brew cycle and whenever the filter is replaced, you may hear the sounds of air being purged from the filter, tubing and water tank(s).
- 11 If the unit is equipped with a hot water faucet, fill a coffee cup with hot water to purge air from the hot water line. On twin units, purge both sides.



## Brewing Instructions

**WARNING - TO AVOID SCALDING, AVOID SPLASHING.** Keep body parts clear of the brewer during brewing. Do not remove the brew basket while "Brewing" appears on the display.

The G3 brewer is factory preset for optimal performance.

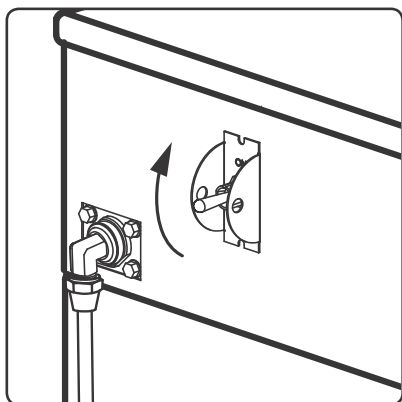

- 1 The brewer should be ON. Confirm this at the rear toggle switch. "Ready to brew" should be on the display.

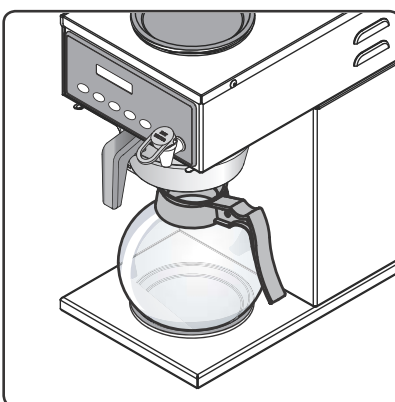

- 2 Center an empty decanter under the brew basket.

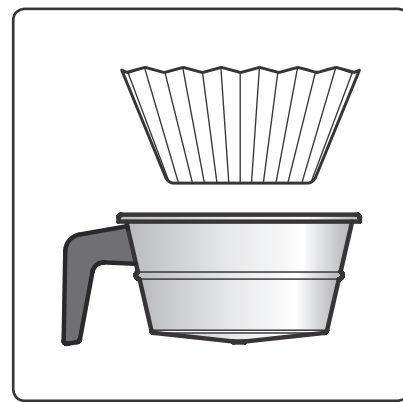

- 3 Insert a clean paper filter into the brew basket.



- 4 Fill with the proper amount of ground coffee. Level the coffee in the filter.

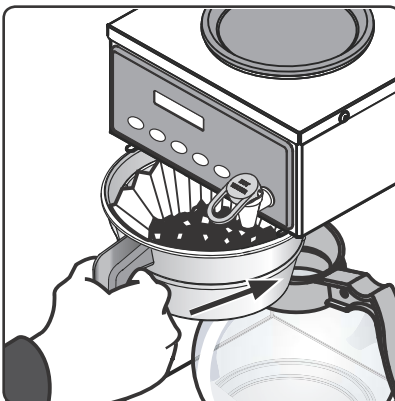

- 5 Slide the filled brew basket into the brew rails under the control panel. Slide it all the way back until it stops.

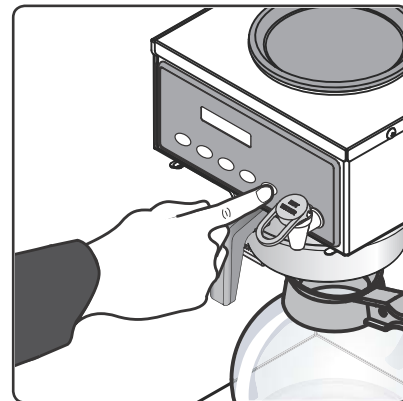

- 6 Press the brew button. Brewing will begin immediately.

The brewer will brew coffee based on the settings programmed into the universal control module (UCM). To change the settings, see the *PROGRAMMING GUIDE* section.

### Easy Access Features

Certain features can be accessed from the front panel without entering programming mode on brewers manufactured in January 2008 and later. Make sure that the rear toggle switch is in the ON position and that the control panel is on (display is lit), before accessing the following features.

#### Brew Volume Adjustment:

- 1 On ALP1GT series models, press and hold button 2 (⊙) until the Volume Adjustment screen appears on the display. On all other Alpha models, make sure the LED above button 2 (⊙) is lit (press and release button 2 if necessary). Then, with the LED above button 2 lit, press and hold button 2 again until the Volume Adjustment screen appears on the display.
- 2 Press buttons 1 (◀) or 3 (▶) to adjust the brew volume up or down. The range is ± 20 ounces.
- 3 Press button 2 (⊙) again to set and exit.

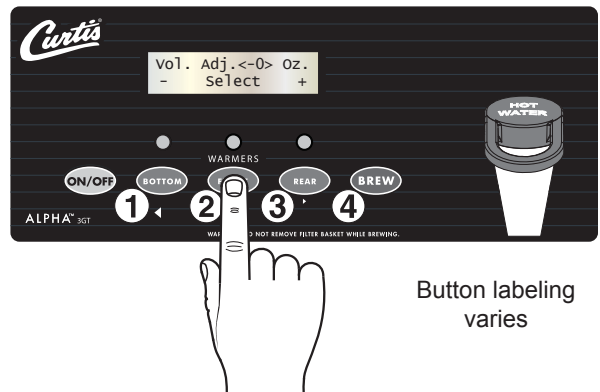

#### Warmer Temperature Control (Factory setting = 90%):

The warmer to be adjusted must be off.

- 1 Press and hold the desired WARMER button until the power adjustment screen appears.
- 2 Press buttons 1 (◀) or 3 (▶) to increase or decrease power to the warmer. The range is 50% to 100%.
- 3 Press button 2 (⊙) to set and exit.
- 4 Press the WARMER button again to turn the warmer off.

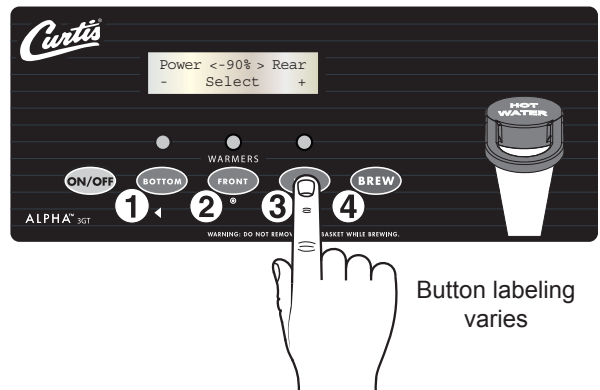

#### Tank Temperature Check

ALP1GT and ALP2GT series models:

Press and hold button 3 (▶) until the tank temperature appears on the display. Release the button. The display will return to the main screen after a few seconds.

ALP3GT, ALP5GT and ALP6GT series models:

Make sure the LED above button 3 (▶) is lit (Press and release button 3 if necessary). With the LED above button 3 lit, press and hold button 3 again until the tank temperature appears on the display. Release the button. The display will return to the main screen after a few seconds.

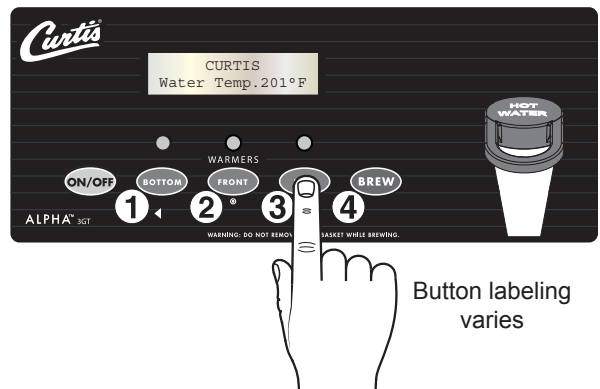



**WARNING: HOT SURFACES** - To avoid injury, allow the brewer and dispenser(s) to cool before cleaning.



**NOTICE** - Do not use cleaning liquids, compounds or powders containing chlorine (bleach) or corrosives. These products promote corrosion and will damage the finishes. **USE OF THESE PRODUCTS WILL VOID THE WARRANTY.**

---

### Cleaning The Brewer - Daily

---



**WARNING:** DO NOT immerse the brewer in water or any other liquid.

---

**The brewer should be OFF.** Turn the brewer off by flipping the rear toggle switch to the OFF position.

- 1 Remove the dispenser(s). Wipe exterior brewer surfaces with a damp cloth to remove spills and debris.
- 2 Remove the brew basket(s) and clean them in a mild detergent solution. Use a soft bristled brush for hard to clean areas. Rinse with clean water, then dry.
- 3 Wipe the spray head area with a cloth soaked in a mild detergent solution. Rinse with a cloth soaked with clean water removing any residual detergent. Use a clean, soft cloth to dry.
- 4 Dump out the drip tray(s) (if applicable). Rinse with clean water, then dry with a soft, clean cloth.

### Cleaning The Brewer - Weekly

**The brewer should be OFF.** Turn the brewer off by flipping the rear toggle switch to the OFF position.

- 1 Remove the spray head(s), unscrewing counterclockwise from the dome plate.
- 2 Thoroughly clean and rinse the dome plate area.
- 3 Clean the brew basket rails with a brush soaked with a mild detergent solution. Rinse the area with a cloth soaked with clean water, removing any residual detergent.
- 4 Dry the area with a soft, clean cloth.
- 5 Reattach the spray head(s).

## Cleaning the Glass Decanters - Daily



**CAUTION: Avoid injury or damage when cleaning glass decanters:** Do not clean with materials that scratch. Curtis glass decanters are dishwasher safe, or may be hand washed. To clean, prepare a mild solution of detergent and warm water or urn cleaning solution intended for coffee decanters.

Remove the decanter from the brewer and rinse it out.

**Wash** - Prepare a mild solution of detergent and warm water. Wipe the exterior surfaces of the decanter with a sponge soaked with the detergent solution to remove spills and debris. Fill the decanter with the detergent solution. Use a sponge cleaning brush to clean inside.

**Rinse** - Rinse the inside and out with clean, warm water.

**Sanitize** - Drop one TABZ Z61 tablet (Curtis PN WC-79003) into the decanter. Fill to the top with hot water (122°F/50°C min.). Stir the contents. Allow the contents to soak for 5 to 10 minutes.

**Rinse** - Pour the sanitizer out. Fill the decanter to the top with clean, warm water and pour it out twice.

**Air Dry** - Empty out the decanter. Turn it upside down and place on the counter. Allow it to air dry.

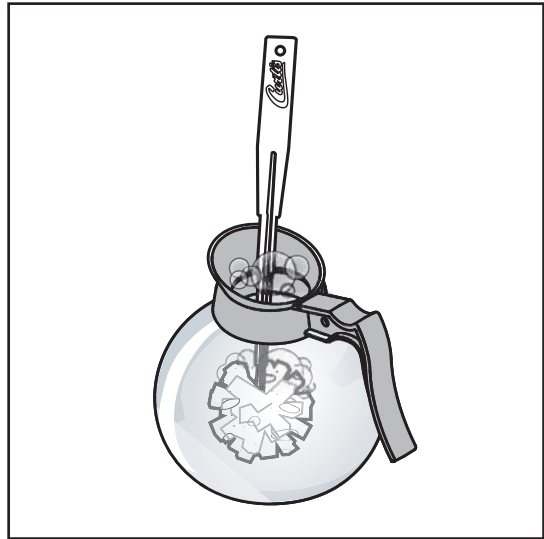

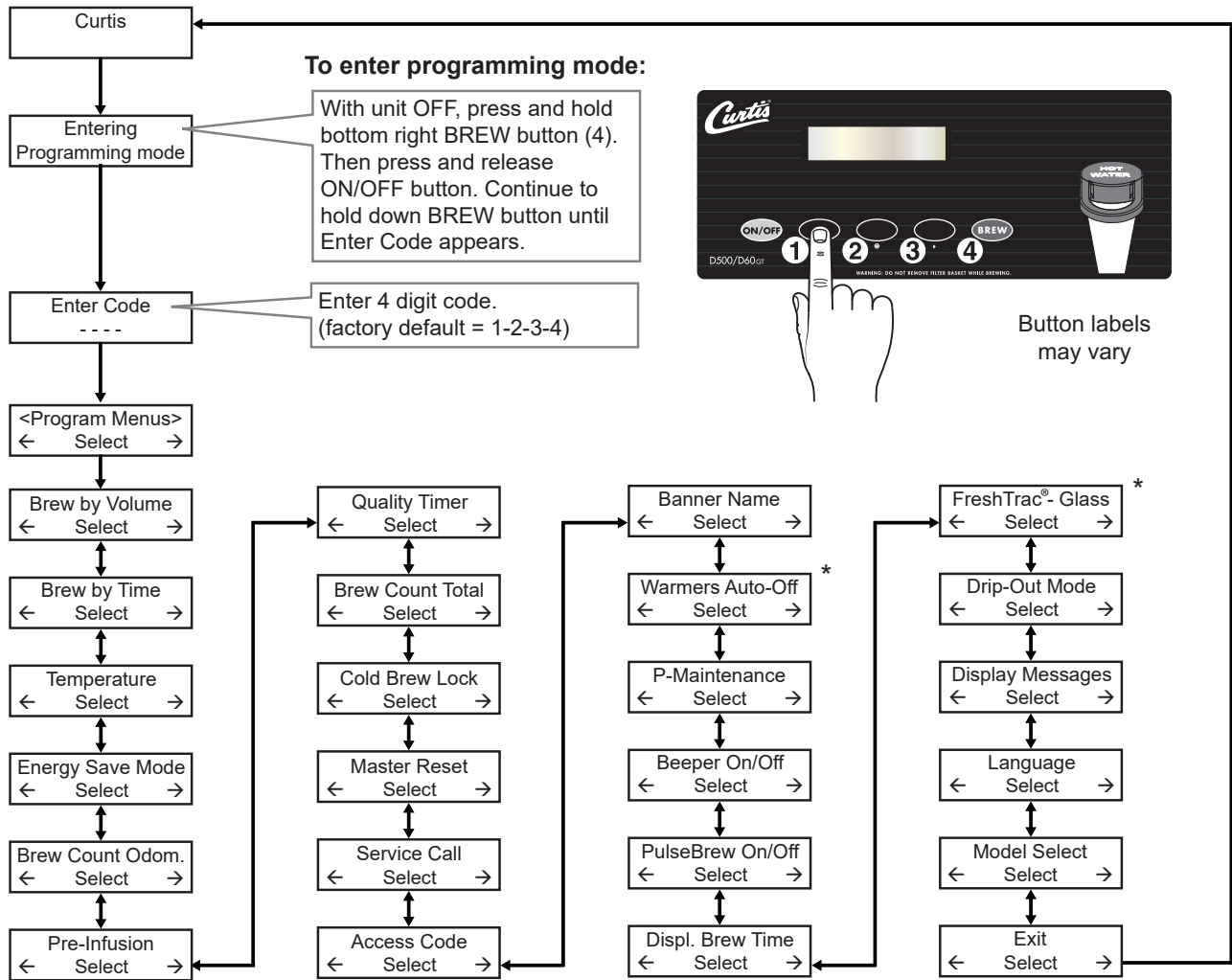

\*Alpha® series brewers only.

**i IMPORTANT:** All programming functions are performed with the three center buttons.

The symbols below the buttons are:

- ◀ Scroll UP (1)
- ⊙ SELECT or ENTER to save new parameter (2)
- ▶ Scroll DOWN (3)

Once you enter programming mode, press ◀ or ▶ to scroll UP or DOWN through the various functions/features. Press ⊙ (Select) to make changes to the function/feature displayed. Then press ◀ or ▶ to scroll through the various available settings. See *Programming Options* for detailed descriptions.

## Programming Options

See the first page of the programming guide for instructions on accessing each individual menu item. Some menus save and exit automatically when a parameter is updated. Other menus exit to the previous menu when a parameter is saved. To exit, press ► until EXIT appears on the display, then press Ⓞ.

**Brew by Volume** - adjusts the volume brewed (the factory default is 74 oz. (2.2 l)). With an empty airpot in place, press the appropriate BREW button. When the desired volume is reached, press the same BREW button again to stop the brew cycle and set the volume.

**Brew by Time** - adjusts the amount of coffee brewed by time rather than by volume (the factory default is 3min-0sec). Once accessed, press ◀ or ▶ until the number of minutes is flashing. Then press Ⓞ repeatedly to change the number value. Press ◀ or ▶ until the number of seconds is flashing. Then press Ⓞ repeatedly to change the number value. Press ◀ or ▶ until "ex" is flashing, then, press Ⓞ to exit.

**Temperature** - sets the brewing temperature of the water held in the water tank (the factory default is 200°F/92°C). The range is 170°F to 206°F (77°C to 97°C). Once accessed, press ◀ or ▶ to choose the desired temperature. Then press Ⓞ to set and exit.

**Energy Save Mode** - saves energy during periods when the brewer is not in use (the factory default is OFF). When set to ON, the brewer automatically shuts off two hours after the last brew cycle. Press the ON/OFF button to return to normal operation. When set to ON 140°F (60°C), the brewer shuts off two hours after the last brew cycle, but the water tank temperature remains at 140°F. Use the ON 140°F setting to reach brewing temperature faster after periods of non-use. Once accessed, press ◀ or ▶ to choose the desired setting. Then press Ⓞ to set and exit.

**Brew Count Odom** - When accessed, this feature displays the total brew cycles since the odometer was last reset. Press ◀ to exit or Ⓞ reset and exit.

**Pre-Infusion** - sets the brewer Pre-Infusion time (Pulse Brew must be off to access, the factory default is Disabled). Pre-Infusion increases control of coffee clarity and extraction. When turned on, the range is 10 to 60 seconds. Once accessed, press ◀ or ▶ to choose the desired setting, then, press Ⓞ to exit. To turn off pulse brew mode, choose 0 for the time.



When Pre-infusion is ON, Pulse Brew disappears from the list of menu items.

**Quality Timer** - notifies the user that the coffee is no longer fresh by monitoring the amount of time since the BREW button was last pressed (the factory default is Off). When time expires, an audio alarm turns on and "Quality Timer" flashes on the display. Once accessed (Ⓞ), press ◀ or ▶ to increase or decrease the amount of time. The range is Off to 120 minutes (2 hours). Press Ⓞ to set and exit.

**Brew Count Total** - when accessed, displays the total brew cycles on the brewer. It cannot be reset. The display returns to the previous screen automatically after a few seconds.

**Cold Brew Lock** - adjusts the temperature at which the brewer will brew coffee when the BREW button is pressed (**Ready to Brew** appears on the display, the factory default is 15°F/8°C). This feature also adjusts the temperature at which the heating element turns on to reheat the water in the tank. The available settings are 5°F (3°C) and 15°F. Once accessed, press ◀ or ▶ to choose the desired setting. Then press Ⓞ to set and exit.

**Master Reset** - resets the brewer universal control module (UCM) to the factory default settings. Once accessed, "Are You Sure?" will appear on the display. Press ◀ for Yes or ▶ for No.

### Programming Options (cont.)

**Service Call** - sets the service phone number that appears on the display when the UCM detects a SENSOR ERROR or WATER ERROR . Once accessed, press ◀ or ▶ to choose the number to be changed. Then press Ⓞ repeatedly to change the number value. Press ◀ or ▶ to choose the next number to change or choose exit and press Ⓞ.

**Access Code** - sets the access code entered to access programming mode (the factory default is 1-2-3-4). Once accessed, press ◀ or ▶ to choose the number to change. Then press Ⓞ repeatedly to change the number value (range is 1 to 4). Press ◀ or ▶ to choose the next number to change or choose exit and press Ⓞ.

**Banner Name** - changes the banner name that appears on the display (the factory default is **Curtis**). No banner name appears when all blanks are entered. Once accessed, press ◀ or ▶ to choose the letter to change. Then press Ⓞ repeatedly to change the letter value. Press ◀ or ▶ to choose the next letter to change or choose ex and press Ⓞ to exit.

**Warmer Auto-Off** - (Alpha series units only) adjusts the length of time that elapses before the warmer(s) shut off automatically. The range is Off to 4 hours (the factory default is Off). Once accessed, press ◀ or ▶ to adjust the number of hours. Then press Ⓞ to set and exit.

**P-Maintenance** - turns on/off and adjusts the P-Maintenance (preventive maintenance) brew monitor (the factory default is OFF). When ON, the UCM measures the number of gallons brewed before the P-Maintenance reminder appears on the display. The range is Off to 9500 gal. (36,000 l). Once accessed, press ◀ or ▶ to choose the desired setting, then, press Ⓞ to exit.

**Beeper On/Off** - turns the beeper that is heard each time a button is pressed on or off (the factory default is ON). Once accessed, press ◀ or ▶ to choose the desired setting. Then, press Ⓞ to exit.

**Pulse Brew** - selects the pulse brew pattern (Pre-Infusion must be off to access, the factory default is C). The pulse brew pattern selected “tunes” or changes the flavor of the coffee. Once accessed, press ◀ or ▶ to choose the desired setting. Then, press Ⓞ to exit.

 When Pulse Brew is on, Cold Brew Lock is set within 5°F (3°C) and, Cold Brew Lock and Pre-Infuson disappear from the list of program selections.

Setting	Description
A	Starts at beginning of brew cycle. 4 cycles of 10 seconds on and 5 seconds off, then on until end of brew cycle.
B	Starts towards end of brew cycle (without drip-out mode). 4 cycles of 5 seconds off and 4 cycles of 10 seconds on. Ends when brew cycle ends.
C	Starts at beginning of brew cycle. 5 cycles of 25 seconds on and 10 seconds off, then on until end of brew cycle.
D	Manually set. Starts 30 seconds after brew cycle starts. Number of pulses is adjustable from 1 to 10. Pulse on time and off time are both adjustable from 5 to 60 seconds.
E	Manually set. Starts at beginning of brew cycle. Number of pulses is adjustable from 1 to 24. Pulse on time and off time are both adjustable from 1 to 150 seconds.

#### Pulse Brew Guidelines

- Filter pack type coffees typically extract better with the A and B pulse setting.
- Decaffeinated coffees typically extract better with the B pulse setting.
- High-yield coffees typically extract better with the C pulse setting. Of course, any of the A, B or C settings may be used to suit your taste profile.
- Settings D and E are manual pulse counts.

## Programming Options (cont.)

**Display Brew Time** - turns the display of the brew time during brewing on or off (the factory default is ON). Once accessed, press ◀ or ▶ to choose the desired setting, then press Ⓞ to exit.

**FreshTrac-Glass** - (Alpha FreshTrac units only) allows the operator to control when the FreshTrac LED on the decanter will flash. Once accessed, press ◀ or ▶ to change the amount of time (the factory default is 30 min.), then press Ⓞ to exit.

**Drip-out Mode** - sets the drip-out mode timer. After water stops flowing, it allows additional time for the water to drain from the brew basket before the brew basket lock releases (the factory default is 2 min.). This feature reduces the chance that the brew basket will be removed too early. The range is OFF to 5 min. Once accessed, press ◀ or ▶ to choose desired setting, then, press Ⓞ to exit.

**Display Messages** - turns display of the message "Rinse Server Before Brewing" ON or OFF (the factory default is ON). Once accessed, press ◀ or ▶ to choose the desired setting, then press Ⓞ to exit.

**Language**- changes the language that appears on the display (the factory default is English). Once accessed, press ◀ or ▶ to choose the desired setting (English or French), then press Ⓞ to set and exit.

**Model Select** - changes the model number and number of batches (to match the label on the universal control module, the factory default is Alpha 3/4/5). Once accessed, press ◀ or ▶ until the model number matching the model number label on the brewer appears, then press Ⓞ. Press ◀ or ▶ until the number of batches matches the number of batch sizes on the UCM label, then press Ⓞ to exit.

ALPHA1/2/3 Coffee Brewers

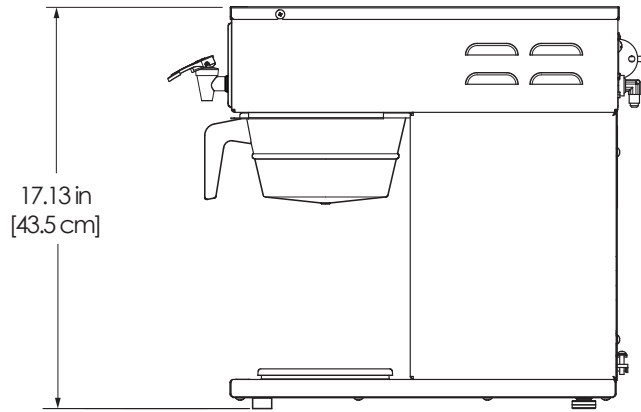

ALP1GT

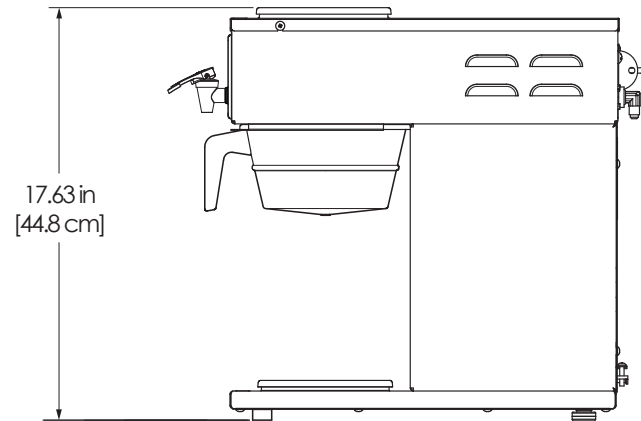
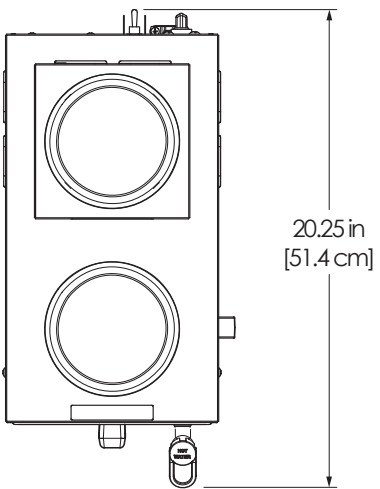

ALP2GT

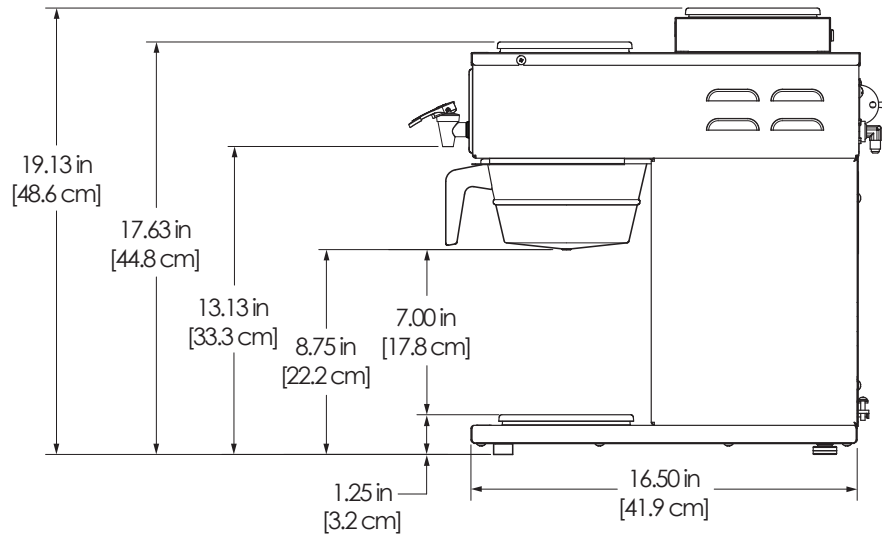
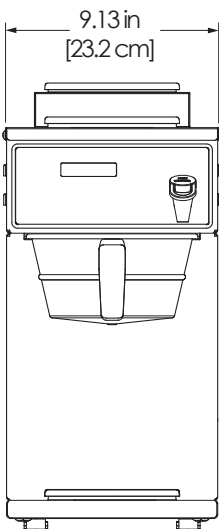

ALP3GT

ALP3GTL Coffee Brewers

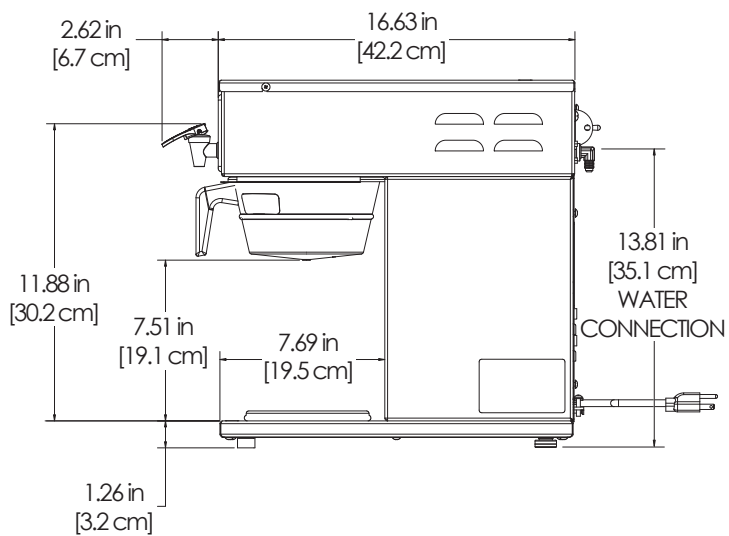
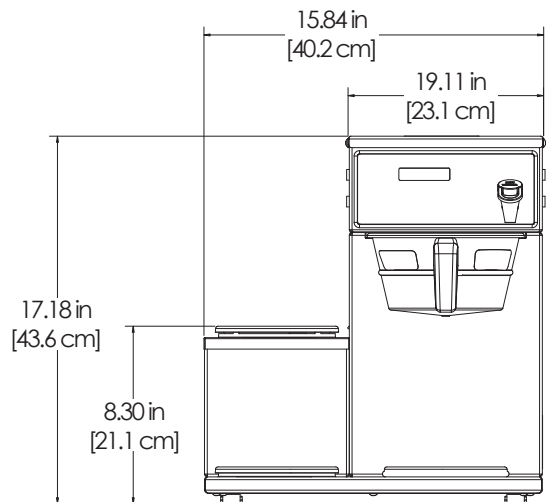
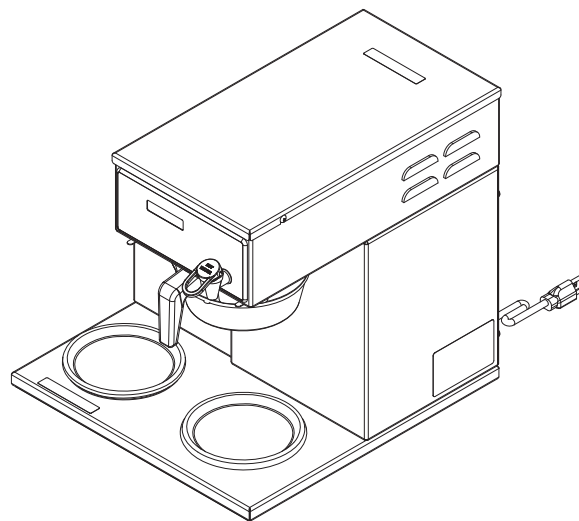
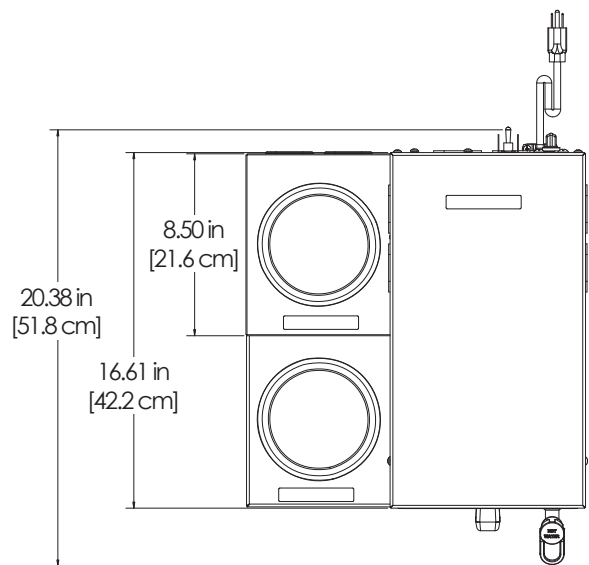

ALP3GTR Coffee Brewers

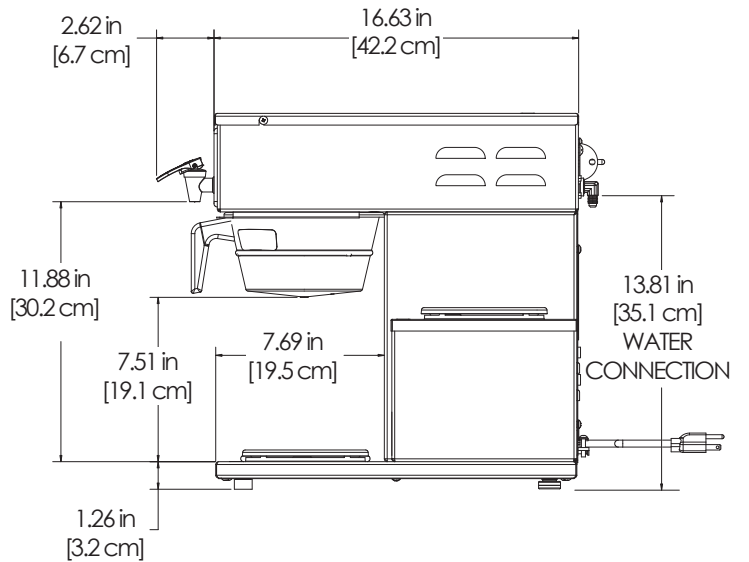
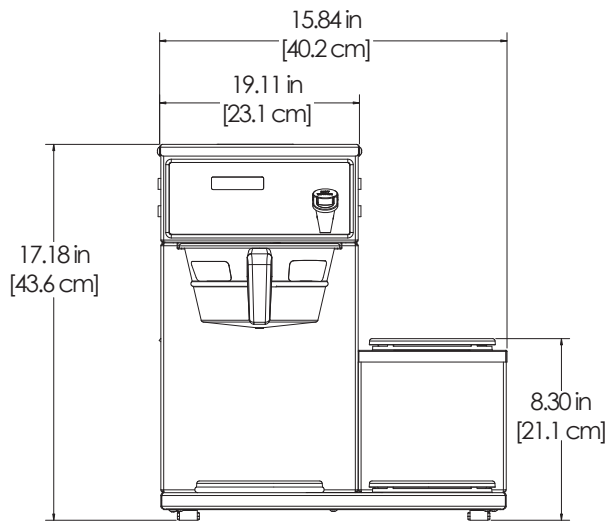
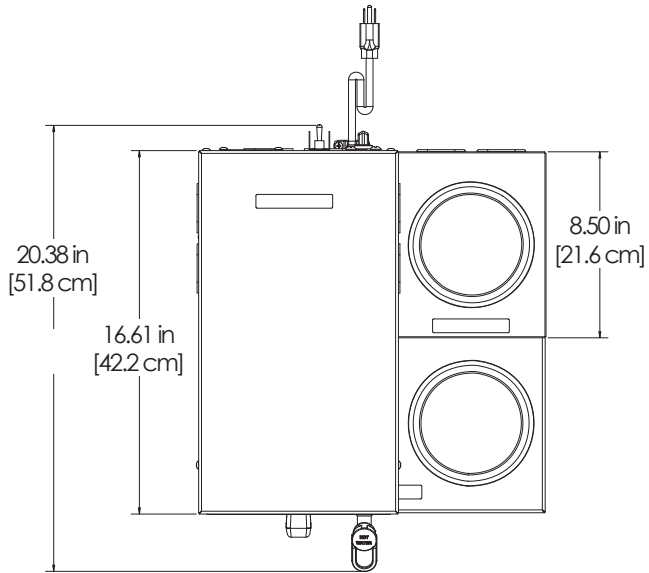

ALP5GT Coffee Brewers

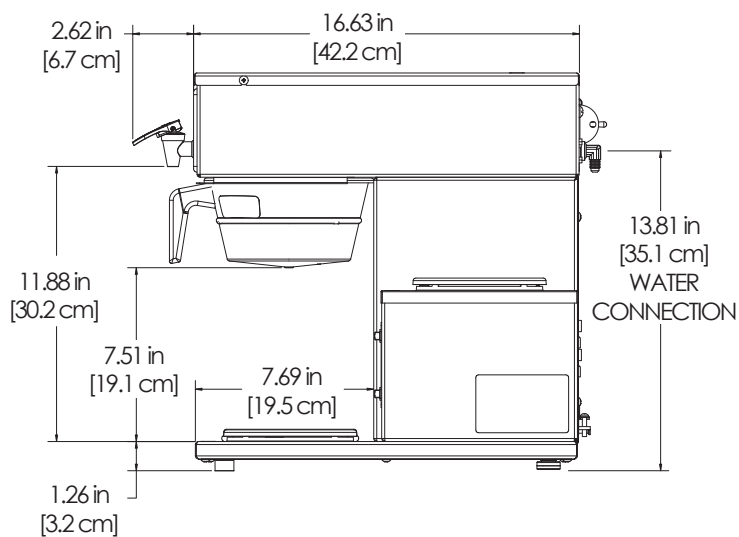
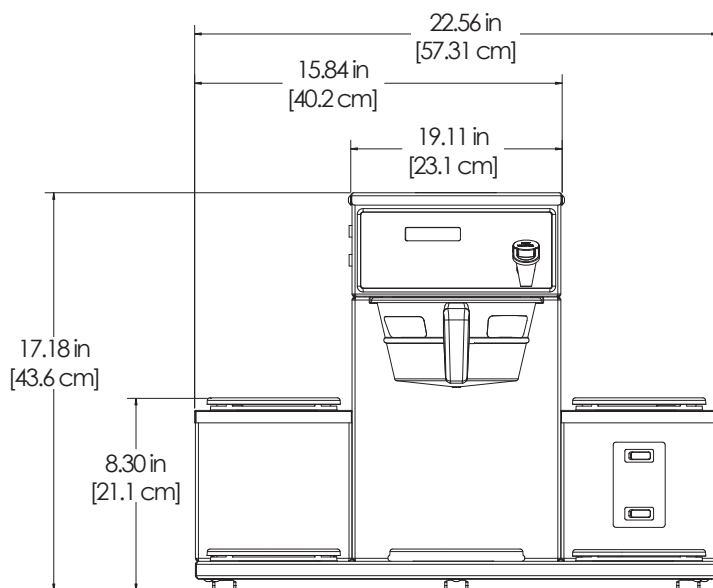
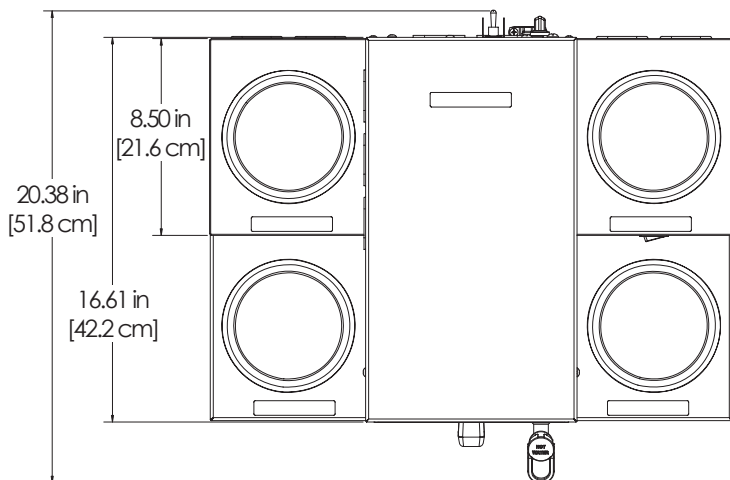

ALP6GT Coffee Brewers

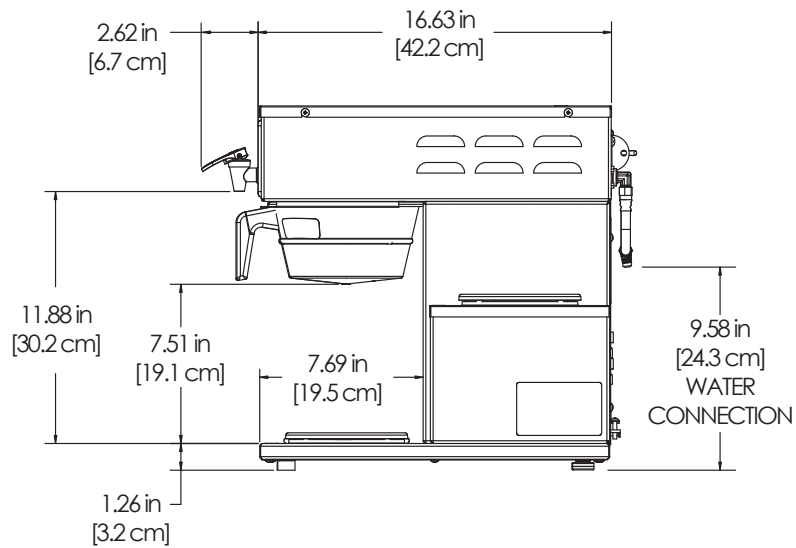
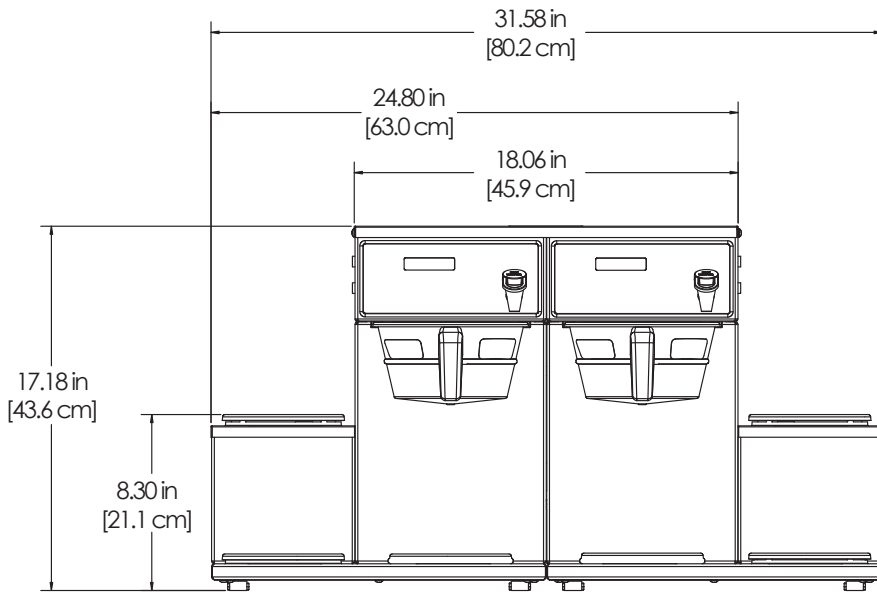
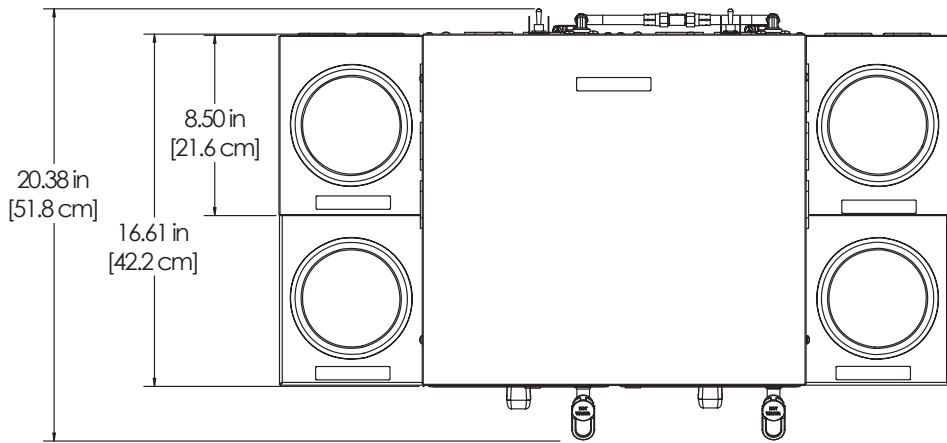

ALP6GTN Coffee Brewers

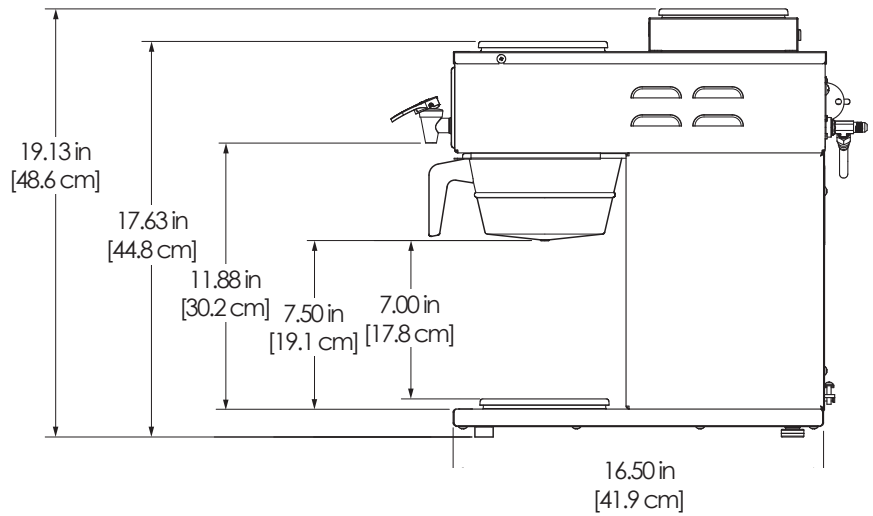
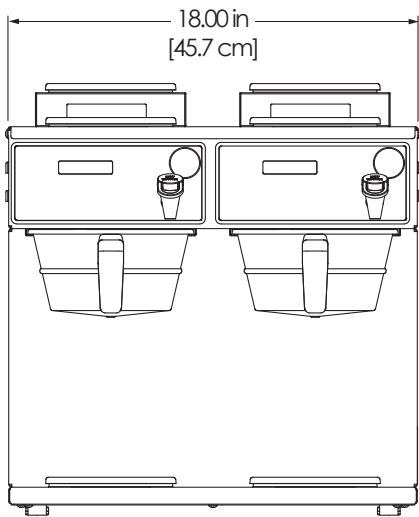
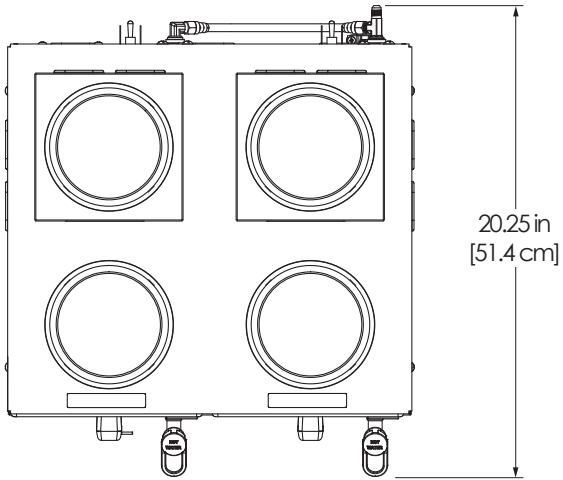

ALPHA - Main Chassis - Exploded View

Water tank assemblies:

- 120 Volt, see section IP57
- Dual Voltage, see section IP58
- 220-240 Volt, see section IP59

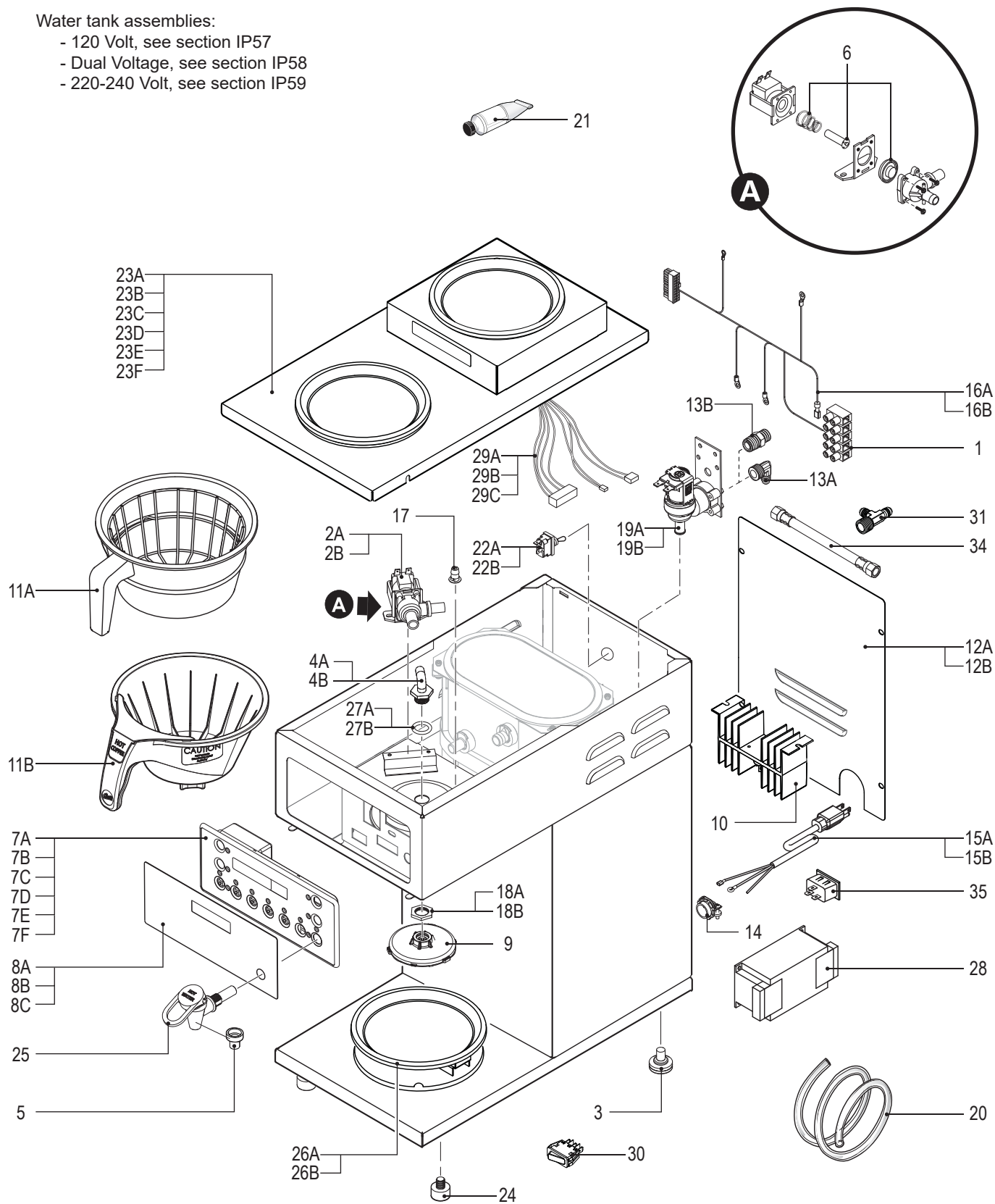

Chassis configuration varies with model

ALPHA - Main Chassis - Parts List

ITEM #	PART #	DESCRIPTION	ITEM #	PART #	DESCRIPTION
1	WC-314 <sup>4,6,8,9,10</sup>	POWER BLOCK, 5 STATION	18A <sup>a</sup>	WC-4213-P	NUT, 5/8 LOCK PLATED
2A*	WC-889 <sup>1,2,3,4,5,6,7,8,9,10</sup>	VALVE, DUMP LEFT 120V 12W ALPHA'S/D1000/GEM-12/TLP	18B <sup>b</sup>	WC-4212-02	NUT, 5/8-18 JAM PLASTIC
2B	WC-860 <sup>11,12,13,14</sup>	VALVE, DUMP LEFT 240V 12W	19A*	WC-826L <sup>1,2,3,4,5,6,7,8,9,10</sup>	VALVE, INLET 1 GPM 120V 9W
3	WC-3518	LEG, GLIDE 3/8"-16 STUD SCREW	19B	WC-856 <sup>11,12,13</sup>	VALVE, INLET 1 GPM 240V 6W
4A <sup>a</sup>	WC-2962K	KIT, FITTING SPRAYHEAD SS	20*	WC-5310	TUBE, 5/16 ID x 1/8W SILICONE GEN USE
4B <sup>b</sup>	WC-2962-101K	KIT, FITTING SPRAYHEAD KYNAR	21*	WC-5231	COMPOUND, HEAT SINK 5OZ
5	WC-1806	SEAT CUP, SILICONE USE ON WC-1809 FAUCET	22A*	WC-102 <sup>1,2,3,5,7</sup>	SWITCH, TOGGLE NON-LIT SPST 15A 125/6A 250VAC RESISTIVE
6*	WC-37132-101	KIT, VALVE REPAIR FOR DELTROL WC-820WDR,WC-821WDR, WC-844WDR	22B*	WC-103 <sup>4,6,8,9,10,11,12,13,14</sup>	SWITCH, TOGGLE NON-LIT DPST 25A 125/250VAC RESISTIVE
7A*	WC-774 <sup>1,2,3,4,5,6,7,8,9,10</sup>	CONTROL MODULE, UCM 120V ALPGT/D500GT/D60GT	23A	WC-58117 <sup>1,5,6,7,8,11</sup>	COVER, TOP ALPGT/D500GT/D60GT TLP/TCTS/CBS/GEMSS
7B	WC-37061 <sup>1</sup>	KIT, LABEL & UCM ALPHA 1GT CURTIS	23B	WC-58019 <sup>2</sup>	COVER, TOP ASSY ALP2GT
7C	WC-37062 <sup>2</sup>	KIT, LABEL & UCM ALPHA-2GT CURTIS	23C	WC-6812 <sup>3,4</sup>	WARMER, TOP ASSY 120V
7D	WC-37063 <sup>3,4,5,6,7,8,9,10</sup>	KIT, LABEL & UCM ALP-3GT/L/R CURTIS	23D	WC-58066 <sup>9</sup>	COVER, TOP ALPHA-6DS/6DD/GT
7E	WC-724 <sup>11,12,13,14</sup>	CONTROL MODULE, UCM 220V ALPGT D500GT/D60GT	23E	WC-8619 <sup>10</sup>	WARMER, TOP ASSY ALP6GT/10GT
7F	WC-37316 <sup>13</sup>	KIT, LABEL & UCM ALP3GT 220V	23F	WC-61108 <sup>13</sup>	COVER, TOP W/A ALPHA-3DS/3DD/5DSL/5DDL/5DSR/DDR/10DS/10DD
8A	WC-39363 <sup>1,11</sup>	LABEL, UCM PANEL ALPHA-1GT CURTIS LOGO	24	WC-3503	LEG, 3/8"-16 STUD SCREW BUMPER
8B	WC-39364 <sup>2,12</sup>	LABEL, UCM PANEL ALPHA-2GT CURTIS LOGO	25	WC-37252	KIT, HOT WATER FAUCET REPLACEMENT ALPGT/D60GT/D500GT
8C	WC-39345 <sup>3,4,5,6,7,8,9,10,13,14</sup>	LABEL, UCM OVERLAY ALPHA-3GT L/R CURTIS LOGO	26A	WC-37135 <sup>1,2,3,4,5,6,7,8,9,10</sup>	WARMER, ASSY COMPLETE 100W 120V
9*	WC-29025	SPRAYHEAD, PURPLE ADVANCE FLOW	26B	WC-975 <sup>11,12,13</sup>	WARMER, ASSY COMPLETE 100W 220V
10	WC-8556	HEATSINK, ASSY DV ALPDS/ D500AP TCTD/PTTD	27A <sup>a</sup>	WC-4320	O'RING, 0.4871.D.x 0.693OD x0.103CS BUNA-N #112
11A	WC-3316 <sup>1,2,3,4,5,6,7,8,9,10,11,12</sup>	BREW CONE, W/HANDLE ASSY 7.1"D.W/WC-3317 & WC-3323 ALP/AP	27B <sup>b</sup>	WC-43089	GASKET, 1.00OD X .625 I.D. X .030 THK WHITE EPDM 70 SHORE
11B	WC-3621-101-P <sup>13</sup>	BREW CONE, NON-METAL UNIVERSAL (WITH SPLASH POCKET)	28	WC-596K <sup>11,12,13,14</sup>	KIT, NOISE FILTER EMI 250V/30A 1PH
12A	WC-5970 <sup>1,2,3,4,5,6,7,8,11,12,13,14</sup>	COVER, BACK CTR WRAP ALPGT	29A	WC-13164 <sup>2,3,4,10,13,14</sup>	HARNESS ASSY, WARMER ALPHA GT FOR UPPER WARMER
12B	WC-61595-101 <sup>9,10</sup>	COVER, BACK ALPHAGT-N	29B	WC-13165 <sup>5,6,7,8,9</sup>	HARNESS ASSY, WARMER ALPHA-3DSR/3DSL/3GTR/3GTL
13A	WC-2401-P	ELBOW 3/8 NPT X 1/4 FLARE	29C	WC-13200-120 <sup>7,8</sup>	HARNESS ASSY, WARMERS 120V ALPHA-5DSR/5DSL
13B	WC-29149	FITTING, ADAPTER 3/8IN MNPT X G3/8 BSPP SS	30	WC-165 <sup>7,8</sup>	SWITCH, WARMER (RED) 120V NEON SPST 20A/250V HI TEMP CAFE/AW
14	WC-1412	CORD GRIP, 3/4" FOR METAL CORD TO .81"OD	31	WC-2705 <sup>10</sup>	TEE, 1/4 X 1/4 FLARE X 3/8 NPT PLATED
15A	WC-1200 <sup>1,2,3,4,5,6</sup>	CORD, 14/3 SJTO 6' BLK W/PLUG	32	WC-13200-120 <sup>7,8</sup>	HARNESS ASSY, WARMERS 120V ALPHA-5DSR/5DSL (NOT SHOWN)
15B	WC-1231-102 <sup>11,12,13</sup>	CORD, 2.5 mm <sup>2</sup> 90°C 36A 450/750 V STRIPPED W/FERRULES ONE END	33	WC-13331-101 <sup>9,10</sup>	WIRE, ASSY ALP6GT/ALP10GT DV SIDE BY SIDE UNITS (NOT SHOWN)
16A	WC-13323 <sup>1,2,3,5,7</sup>	HARNESS ASSY, CONTROL 120V W/O POWER BLOCK ALPHA-GT/GS	34	WC-53169-12 <sup>9,10</sup>	TUBE ASSY, BRAIDED 1/4 FLARE X 11-1/4" LG W/FITTINGS
16B	WC-13315 <sup>4,6,8,9,10</sup>	HARNESS ASSY, CONTROL 120/220V W/POWER BLOCK ALPHA-GT/GS (INCLUDES POWER BLOCK)	35	WC-1522 <sup>14</sup>	SOCKET, POWER INLET 16A/250V SNAP-IN
17	WC-29044-101	SLEEVE, OVERFLOW			

\* Recommended parts to stock.

<sup>a</sup> Newer units. Stainless steel fitting kit (4A) is compatible with older units.

<sup>b</sup> Older units.

<sup>1</sup> ALP1GT12, <sup>2</sup> ALP2GT12, <sup>3</sup> ALP3GT12, <sup>4</sup> ALP3GT63, <sup>5</sup> ALP3GTL/R12,

<sup>6</sup> ALP3GTL/R63, <sup>7</sup> ALP5GT12, <sup>8</sup> ALP5GT63, <sup>9</sup> ALP6GT63, <sup>10</sup> ALP6GTN63,

<sup>11</sup> ALP1GT32, <sup>12</sup> ALP2GT32, <sup>13</sup> ALP3GT32, <sup>14</sup> ALP2GT34

WC-6289 - Tank Assembly - 120 Volt

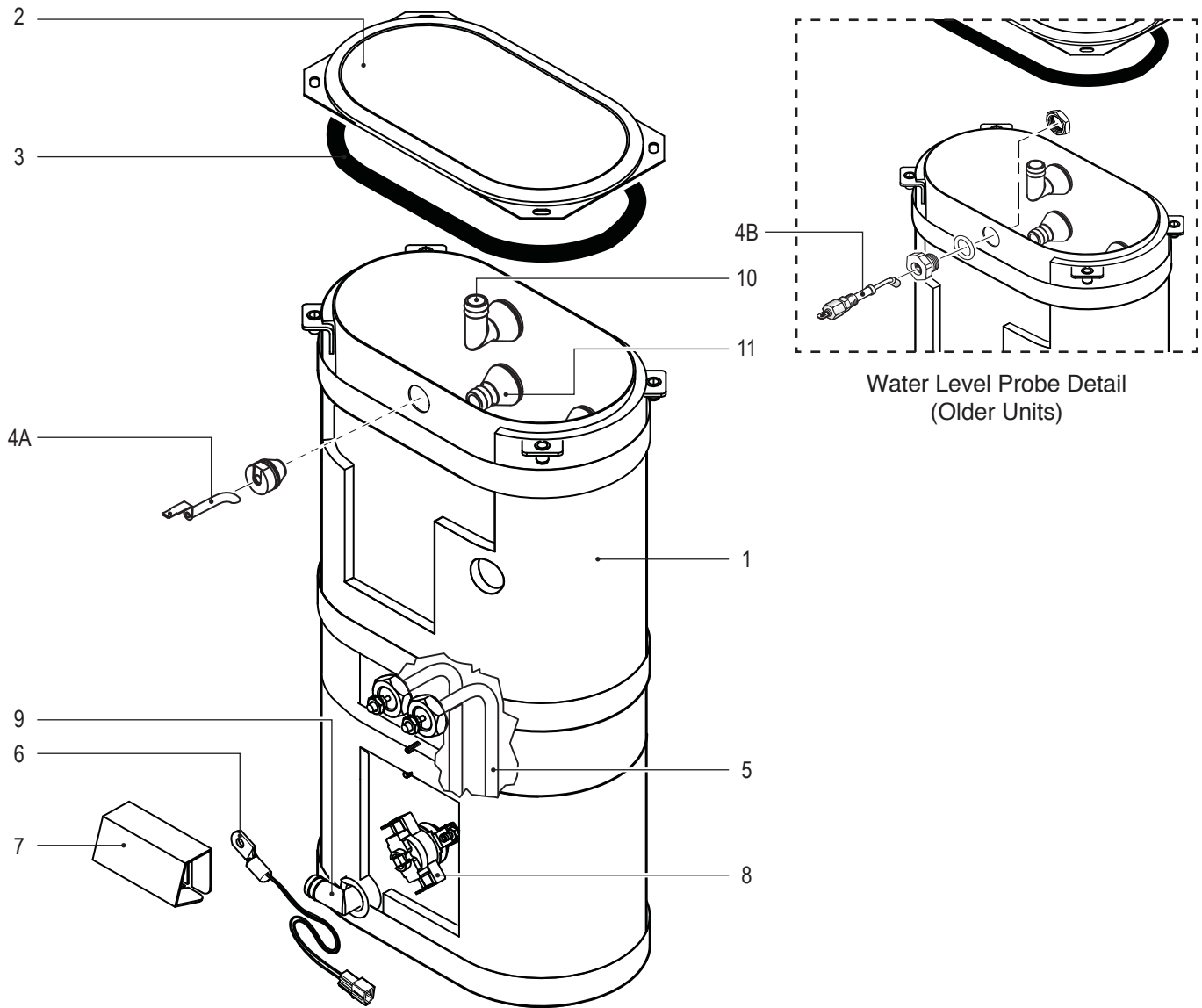

Parts List

ITEM #	PART #	DESCRIPTION
1	WC-6289	TANK, COMPLETE ALPHA-GT 120V W/WC- 523 HI LIMIT THERMOSTAT
2	WC-5853-102	COVER, TOP HEATING TANK GEN USE
3	WC-43062*	GASKET, TANK LID
4A <sup>1</sup>	WC-5528K*	KIT, WATER LEVEL PROBE, SILICONE
4B <sup>2</sup>	WC-5502-01*	KIT, PROBE, ASSY WATER LEVEL W/HEX FITTING, O-RING & NUT
5	WC-917-04*	ELEMENT, HEATING 1.45KW 120V W/JAM NUTS & SILICONE O-RING

ITEM #	PART #	DESCRIPTION
6	WC-1438-101*	SENSOR, TEMPERATURE TANK
7	WC-4394*	GUARD, SHOCK/HEATING ELEMENT FOR SINGLE HEATING ELEMENT
8	WC-523*	THERMOSTAT, MANUAL RESET 120/ 240 VAC 25A 220 DEG F MAX
9	WC-37365*	KIT, FITTING TANK INLET
10	WC-37266*	KIT, FITTING TANK OVERFLOW
11	WC-37317*	KIT, STRAIGHT FITTING & BUSHING 8mm GEN USE

<sup>1</sup> Units built 01/04/2019 and later.

<sup>2</sup> Units built before 01/04/2019. Replaces WC-5527.

\* Recommended parts to stock.

WC-6285 - Tank Assembly - Dual Voltage

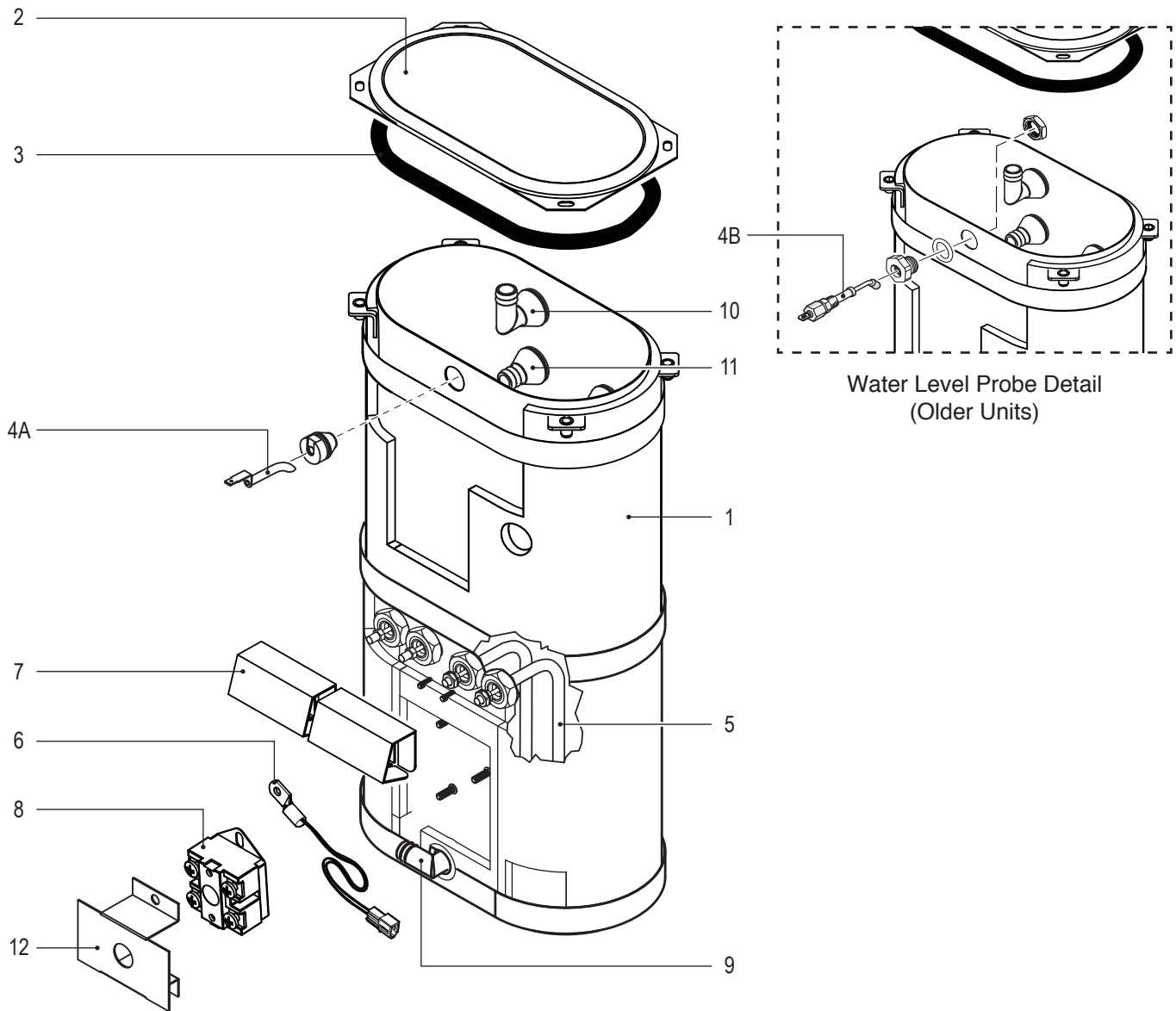

Parts List

ITEM #	PART #	DESCRIPTION
1	WC-6285	TANK, COMPLETE ALPHA-GT DV 120/220V
2	WC-5853-102	COVER, TOP HEATING TANK GEN USE
3	WC-43062*	GASKET, TANK LID
4A <sup>1</sup>	WC-5528K*	KIT, WATER LEVEL PROBE, SILICONE
4B <sup>2</sup>	WC-5502-01*	KIT, PROBE, ASSY WATER LEVEL W/HEX FITTING, O-RING & NUT
5	WC-917-04*	ELEMENT, HEATING 1.45KW 120V W/JAM NUTS & SILICONE O-RING
6	WC-1438-101*	SENSOR, TEMPERATURE TANK

ITEM #	PART #	DESCRIPTION
7	WC-4394*	GUARD, SHOCK/HEATING ELEMENT FOR SINGLE HEATING ELEMENT
8	WC-522*	THERMOSTAT, HI LIMIT HEATER CONTROL DPST 277V 40A
9	WC-37365*	KIT, FITTING TANK INLET
10	WC-37266*	KIT, FITTING TANK OVERFLOW
11	WC-37317*	KIT, STRAIGHT FITTING & BUSHING 8mm GEN USE
12	WC-43055*	GUARD, SHOCK RESET THERMOSTAT (WC-522)

<sup>1</sup> Units built 01/04/2019 and later.

<sup>2</sup> Units built before 01/04/2019. Replaces WC-5527.

\* Recommended parts to stock.

WC-6267(-34) - Tank Assembly - 220-240 Volt

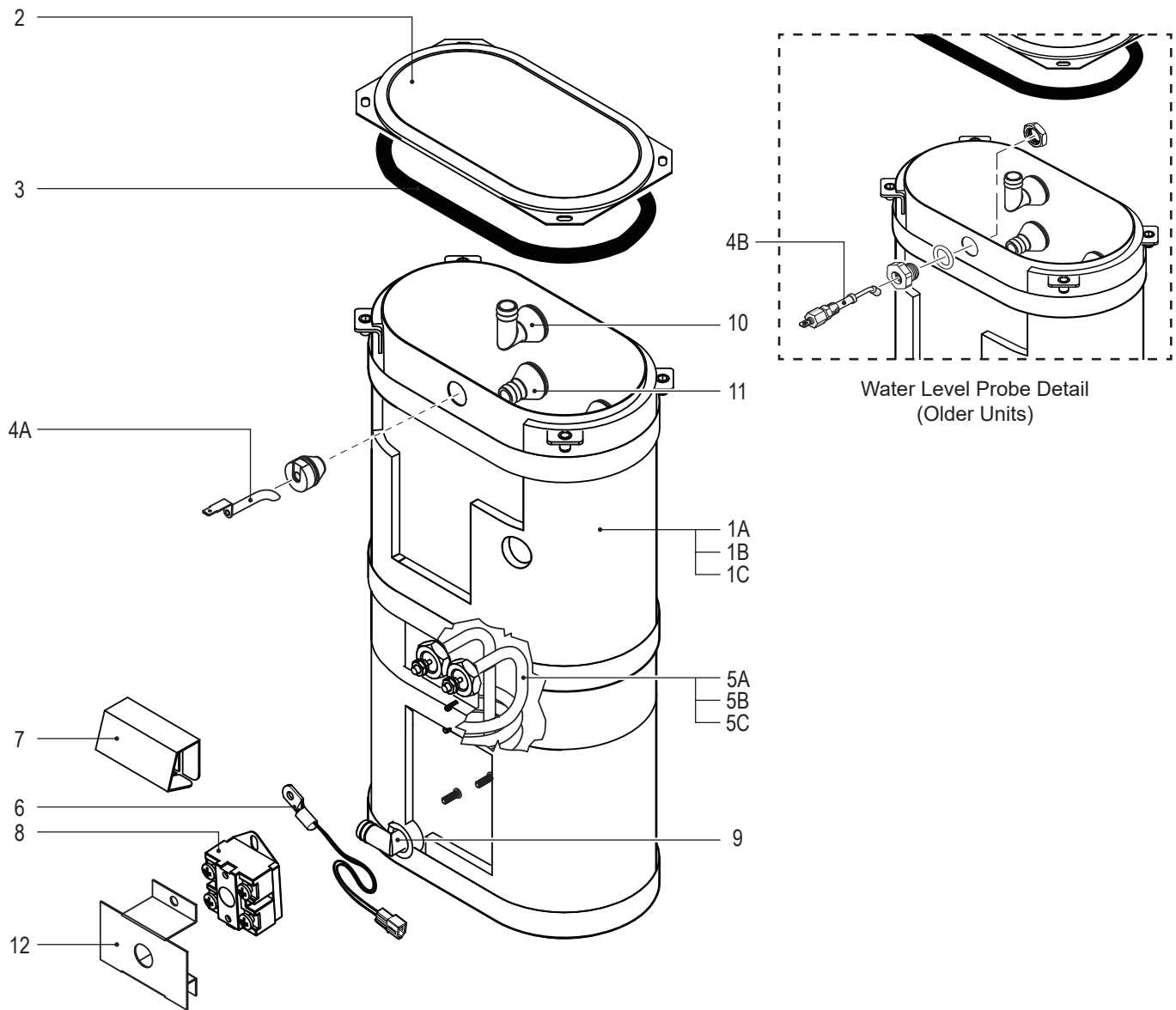

Parts List

ITEM #	PART #	DESCRIPTION
1A	WC-6267	TANK, COMPLETE ALP-DS/GT 220V
1B	<a href="#">WC-6267-34</a>	TANK, COMPLETE 2000W 220V (WC-906 ) ALPHAGT
1C	WC-75157-18	TANK, ASSY 2500W 220V ALPHA-GT
2	WC-5853-102	COVER, TOP HEATING TANK GEN USE
3	WC-43062*	GASKET, TANK LID
4A <sup>1</sup>	WC-5528K*	KIT, WATER LEVEL PROBE, SILICONE
4B <sup>2</sup>	<a href="#">WC-5502-01*</a>	KIT, PROBE, ASSY WATER LEVEL W/HEX FITTING, O-RING & NUT

ITEM #	PART #	DESCRIPTION
5A	WC-922-04*	KIT,ELEMENT HEATING 3.5KW 220V W/JAM NUTS & SILICONE WASHERS
5B	WC-906-04	KIT, ELEMENT, HEATING 2KW 220V W/ JAM NUT & SILICONE O-RING
5C	WC-934-04	KIT,ELEMENT HEATING 2.5KW 220V W/ JAM NUT & SILICONE WASHERS
6	<a href="#">WC-1438-101*</a>	SENSOR, TEMPERATURE TANK
7	WC-4394*	GUARD, SHOCK/HEATING ELEMENT FOR SINGLE HEATING ELEMENT
8	WC-522*	THERMOSTAT, HI LIMIT HEATER CONTROL DPST 277V 40A
9	<a href="#">WC-37365*</a>	KIT, FITTING TANK INLET
10	<a href="#">WC-37266*</a>	KIT, FITTING TANK OVERFLOW
11	WC-37317*	KIT, STRAIGHT FITTING & BUSHNG 8mm GEN USE
12	WC-43055*	GUARD, SHOCK RESET THERMOSTAT (WC-522)

<sup>1</sup> Units built 01/04/2019 and later.

<sup>2</sup> Units built before 01/04/2019. Replaces WC-5527.

\* Recommended parts to stock.



ALPHA1GT/2GT/3GT/5GT - DUAL VOLTAGE

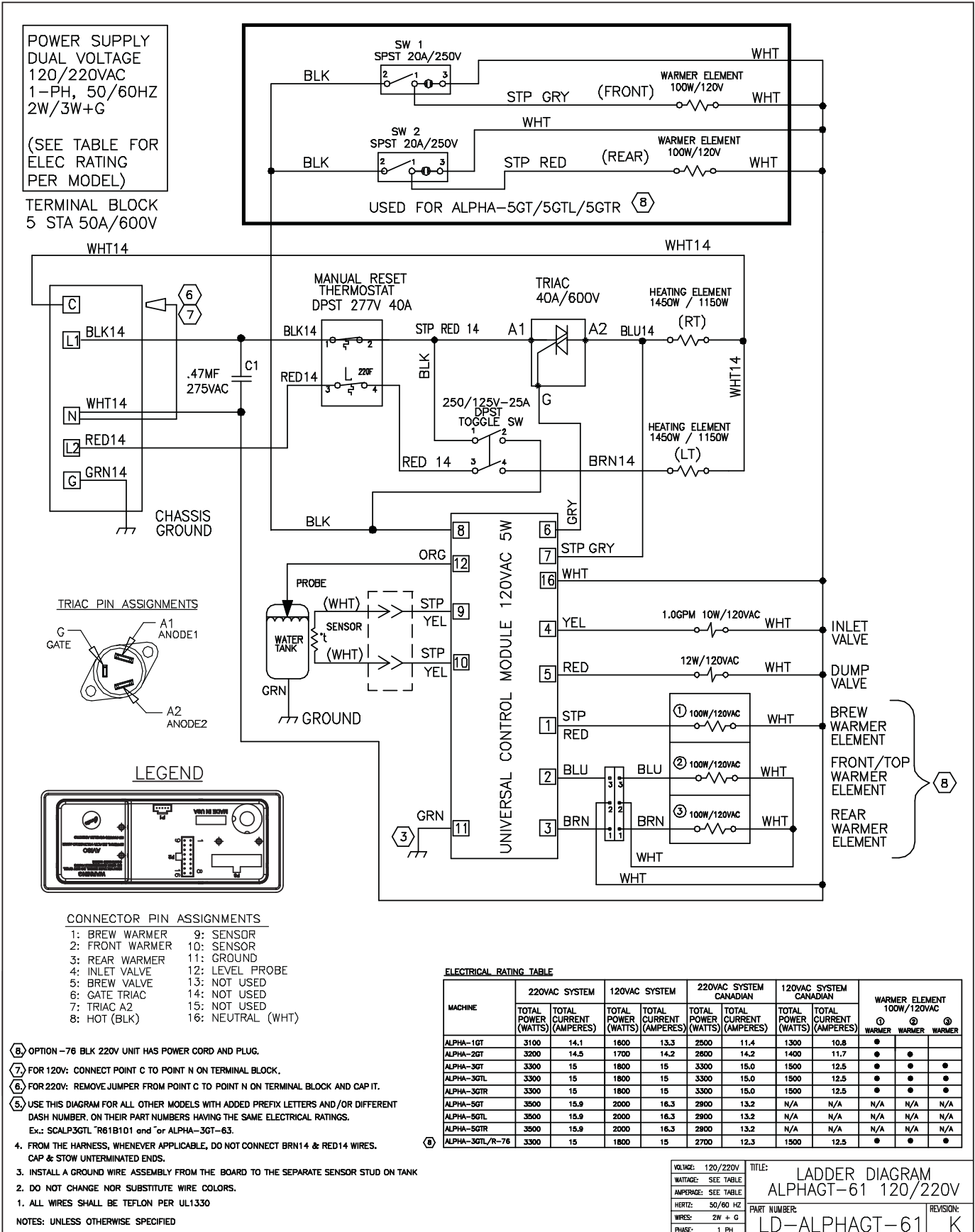

ALPHA6GTN - Dual Voltage - Sheet 1

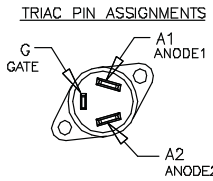
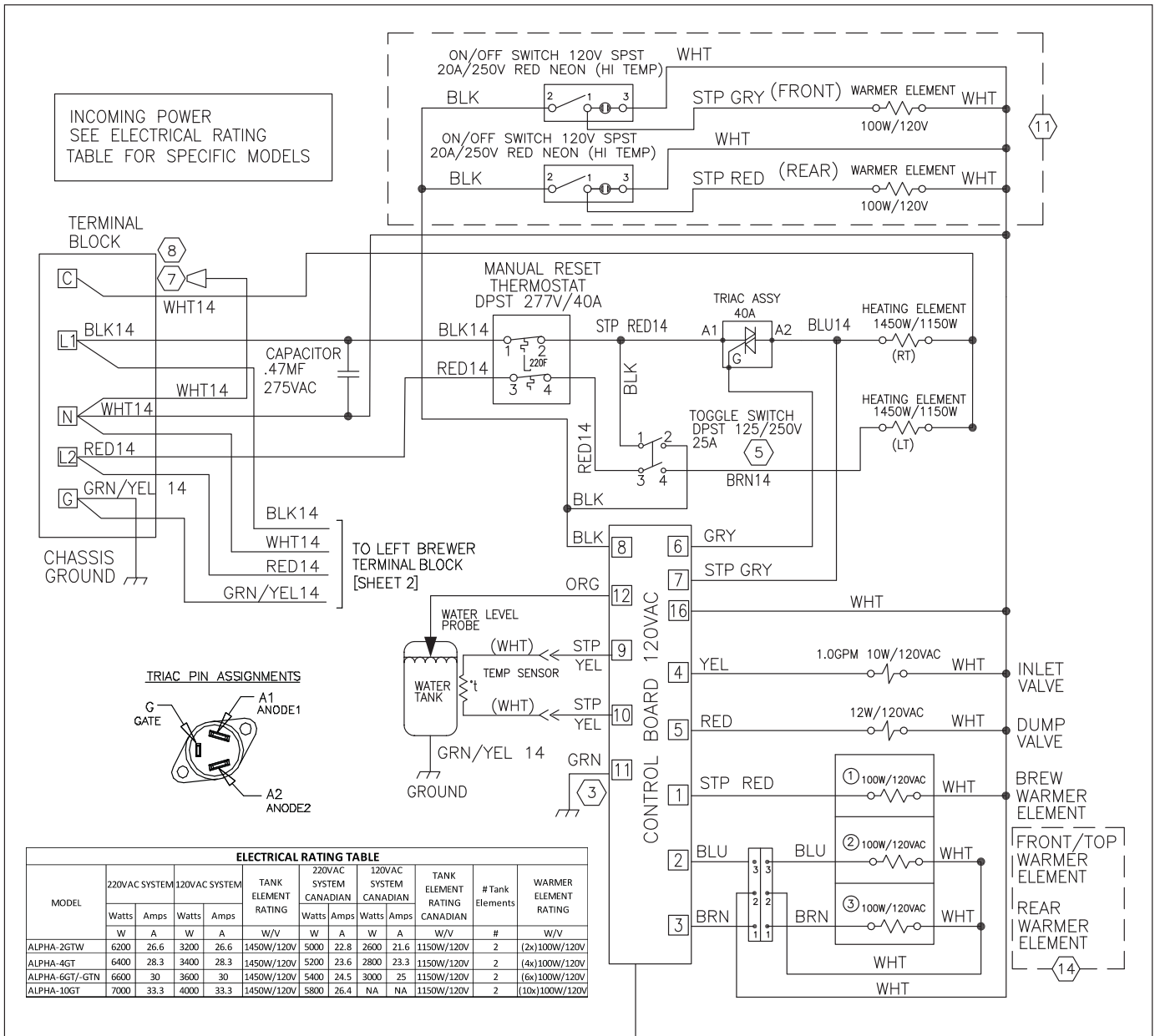

MODEL	220VAC SYSTEM		120VAC SYSTEM		TANK ELEMENT RATING	220VAC SYSTEM CANADIAN		120VAC SYSTEM CANADIAN		TANK ELEMENT RATING CANADIAN	# Tank Elements	WARMER ELEMENT RATING
	Watts	Amps	Watts	Amps		Watts	Amps	Watts	Amps			
	W	A	W	A		W/V	W	A	W			
ALPHA-2GTW	6200	26.6	3200	26.6	1450W/120V	5000	22.8	2600	21.6	1150W/120V	2	(2x)100W/120V
ALPHA-4GT	6400	28.3	3400	28.3	1450W/120V	5200	23.6	2800	23.3	1150W/120V	2	(4x)100W/120V
ALPHA-6GT/-GTN	6600	30	3600	30	1450W/120V	5400	24.5	3000	25	1150W/120V	2	(6x)100W/120V
ALPHA-10GT	7000	33.3	4000	33.3	1450W/120V	5800	26.4	NA	NA	1150W/120V	2	(10x)100W/120V

UCM Pin Assignments	
16 Pin Connector	
1	BREW WARMER
2	FRONT WARMER-TOP
3	REAR WARMER-TOP
4	INLET VALVE
5	BREW VALVE
6	GATE, TRIAC
7	TRIAC A2
8	HOT, (L1)
9	TANK TEMPERATURE SENSOR
10	TANK TEMPERATURE SENSOR
11	UCM GROUND
12	WATER LEVEL PROBE
13	NOT USED
14	NOT USED
15	NOT USED
16	NEUTRAL (N)

- 15. USE THIS DIAGRAM FOR ALL OTHER MODELS WITH ADDED PREFIX LETTERS AND/OR SUFFIX NUMBERS ON THEIR PART NUMBERS HAVING THE SAME ELECTRICAL RATINGS.
  - (14) NOT USED ON ALPHA-2GTW MODELS.
  - 13. FOR ALPHA-4GTR-61 UNIT USE: ONE (1) ALPHA-3GTR & ONE (1) ALPHA-1GT SCREWED TOGETHER ACCORDINGLY WITH PROPER MODEL LAYOUT.
  - 12. FOR ALPHA-4GTL-61 UNIT USE: ONE (1) ALPHA-3GTL & ONE (1) ALPHA-1GT SCREWED TOGETHER ACCORDINGLY WITH PROPER MODEL LAYOUT.
  - (11) NOT USED ON ALPHA-6GT MODELS.
  - 10. FOR ALPHA-10GT-63 UNIT USE: ONE (1) ALPHA-5GTL-61 & ONE (1) ALPHA-5GTR-61 SCREWED TOGETHER WITH A COMMON TOP COVER.
  - 10.1. FOR ALPHA-6GT-63 UNIT USE: ONE (1) ALPHA-3GTL-61 & ONE (1) ALPHA-3GTR-61 SCREWED TOGETHER WITH A COMMON TOP COVER.
  - (8) FOR 120V OPERATION: REMOVE WIRE CAP FROM WHT 14GA JUMPER WIRE AND CONNECT TO POINT "C" OF TERMINAL BLOCK.
  - (7) FOR 220V OPERATION (FACTORY DEFAULT): WHT 14GA JUMPER WIRE TO BE DISCONNECTED AND CAPPED.
  - (5) ADD 'STAND BY' STICKER WC-38034 OVER 'OFF' MARKING ON SWITCH GUARD WHENEVER APPLICABLE.
  - 4. REFER TO PROCESS SPEC PS-001 FOR COLOR ASSIGNMENTS ON CALL-OUT FOR REFERENCE.
  - (3) INSTALL A GROUND WIRE ASSEMBLY FROM THE BOARD TO THE SENSOR STUD; GROUND LUG MUST BE INSTALLED OVER THE SENSOR, DO NOT INSTALL ON TANK LID SCREWS.
  - 2. DO NOT CHANGE NOR SUBSTITUTE WIRE COLORS.
  - 1. ALL WIRES SHALL BE MIN. 18 GA. PER UL1015 UNLESS NOTED.
- NOTES: UNLESS OTHERWISE SPECIFIED

[SHEET 1]

VOLUME: SEE ELECTRICAL TABLE	TITLE: LADDER DIAGRAM
WATTAGE: SEE ELECTRICAL TABLE	PART NUMBER: LD-ALPHA10GT-63
AMPERAGE: SEE ELECTRICAL TABLE	REVISION: F
HERTZ: 50/60Hz	
WIRING: 2W/3W + G	
PHASE: 1 PHASE	

ALPHA6GTN - Dual Voltage - Sheet 2

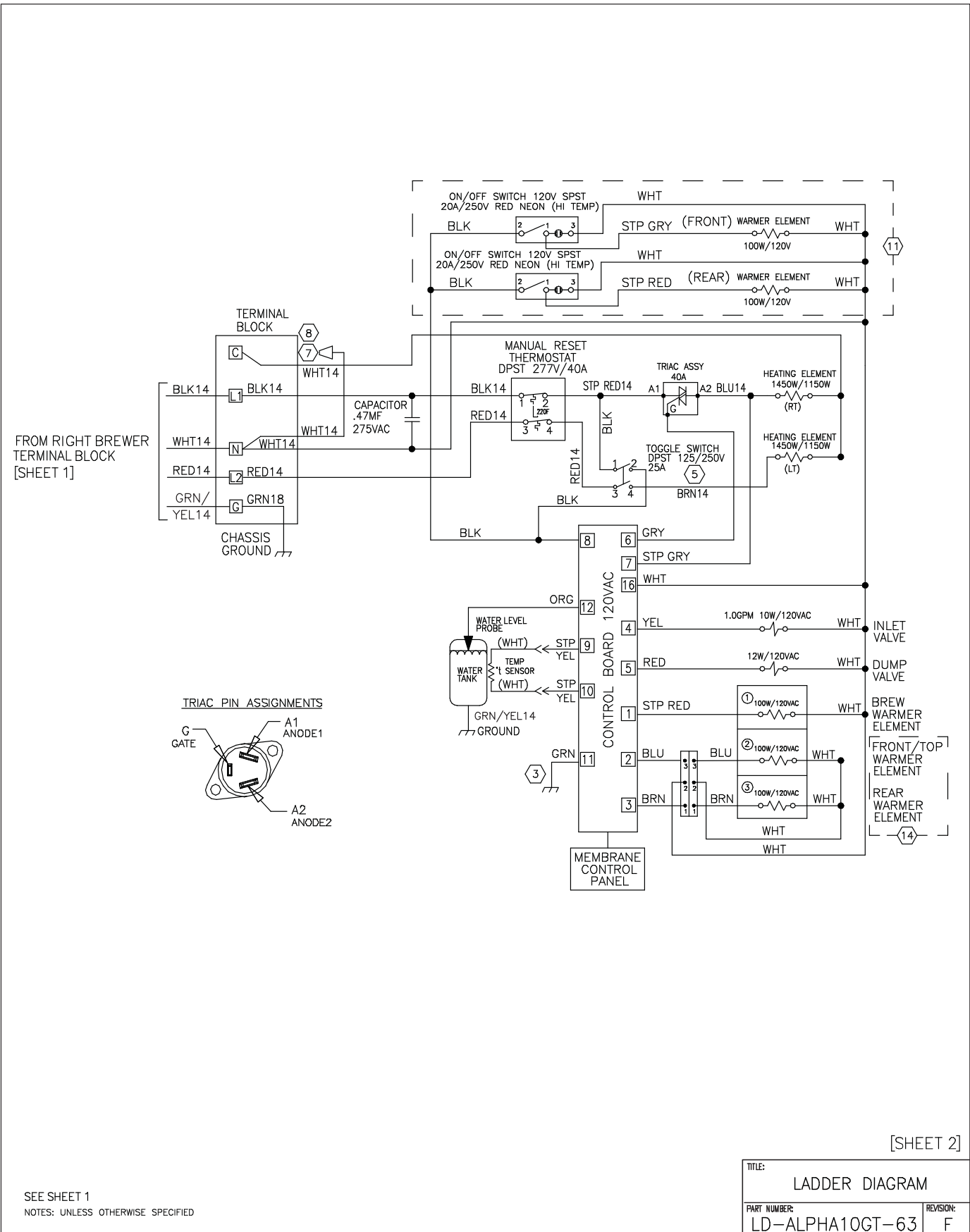

[SHEET 2]

TITLE:		LADDER DIAGRAM	
PART NUMBER:		LD-ALPHA10GT-63	
REVISION:		F	

ALPHA - 220-240 Volt (2500/3500 Watt)

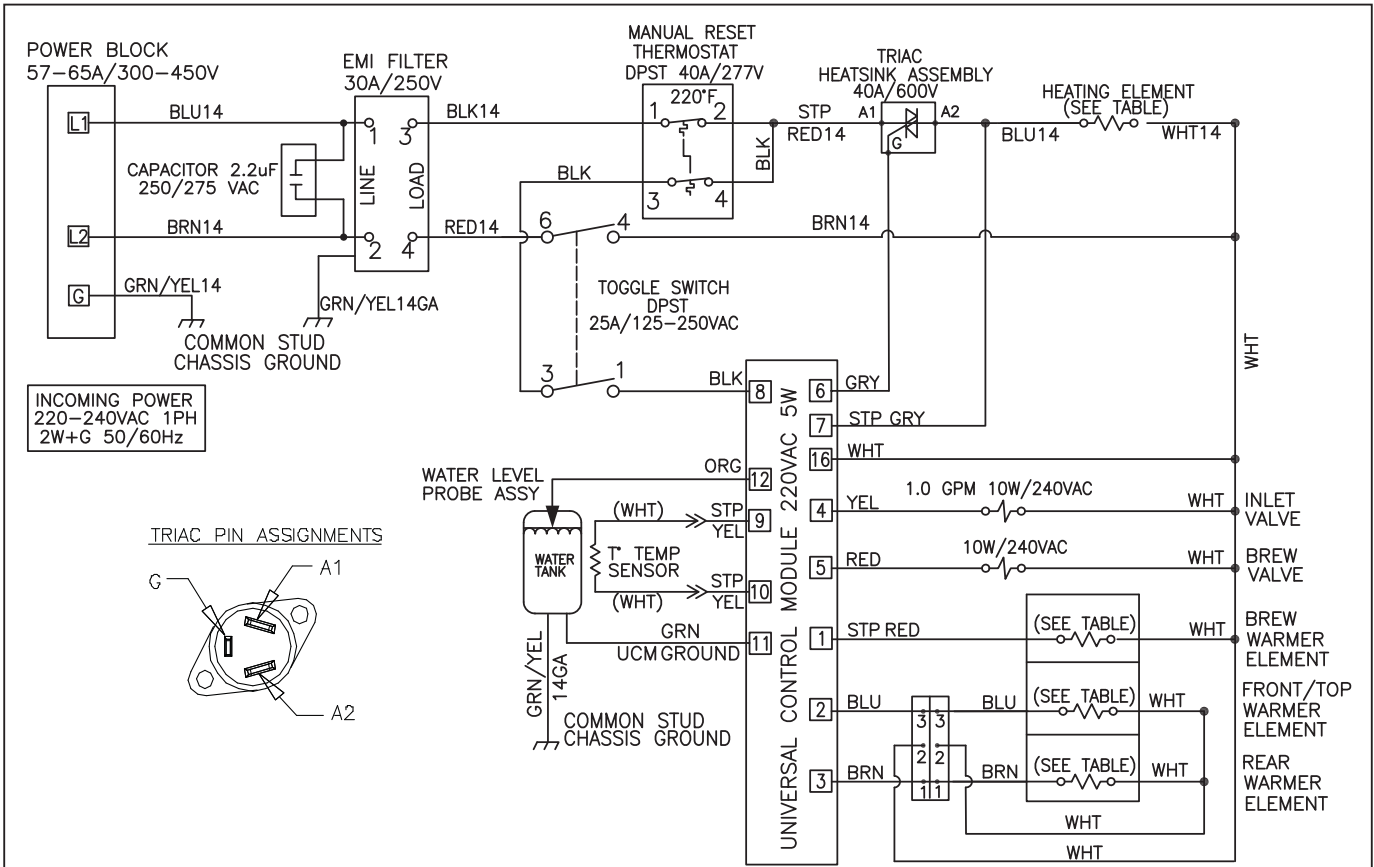

INCOMING POWER  
220-240VAC 1PH  
2W+G 50/60Hz

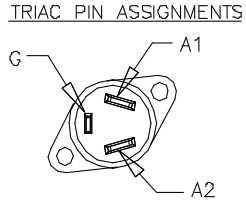

UCM Pin Assignments	
16 Pin Connector	
1	BREW WARMER
2	FRONT WARMER-TOP
3	REAR WARMER-TOP
4	INLET VALVE
5	BREW VALVE
6	TRIAC GATE
7	TRIAC A2
8	230V L1
9	TANK TEMPERATURE SENSOR
10	TANK TEMPERATURE SENSOR
11	UCM GROUND
12	WATER LEVEL PROBE
13	NOT USED
14	NOT USED
15	NOT USED
16	230V L2

ELECTRICAL RATING TABLE									
Model	Voltage V	Amps A	Watts W	Hertz Hz	# of Conductor Wires	Phase	# of Tank Elements	Tank Element Rating W/V	Warmer Element Rating W/V
ALP1GT32Ax	220	12.3	2700	50/60	2	1	1	2500W/220V	(1X) 100/220
ALP2GT32Ax		12.7	2800						(2X) 100/220
ALP3GT32Ax		13.2	2900						(3X) 100/220
ALP3GTL32Ax									(1X) 100/220
ALP3GTR32Ax									
ALP1GT32Ax		230	13.2						3044
ALP2GT32Ax	13.7		3153	(2X) 100/220					
ALP3GT32Ax	14.2		3263	(3X) 100/220					
ALP3GTL32Ax				(1X) 100/220					
ALP3GTR32Ax					(2X) 100/220				
ALP1GT32Ax	240		13.4	3215	50/60	2	1	3500W/220V	(1X) 100/220
ALP2GT32Ax		13.9	3330	(2X) 100/220					
ALP3GT32Ax		14.4	3450	(3X) 100/220					
ALP3GTL32Ax				(1X) 100/220					
ALP3GTR32Ax									(2X) 100/220
ALP2GT32A098		220	17.3	3800					50/60
ALP3GT32A098	17.7		3900	(3X) 100/220					
ALP3GTR32A098	18.1		4153	(2X) 100/220					
ALP2GT32A098				(1X) 100/220					
ALP3GT32A098					(3X) 100/220				
ALP3GTL32A098	18.5		4263	(2X) 100/220					
ALP3GTR32A098		(3X) 100/220							
ALP2GT32A098	230	19.0	4550	50/60	2	1	3500W/220V	(2X) 100/220	
ALP3GT32A098		19.4	4650					(3X) 100/220	
ALP3GTR32A098								(3X) 100/220	

2. USE THIS DIAGRAM FOR ALL OTHER MODELS WITH ADDED PREFIX LETTERS AND/OR SUFFIX NUMBERS ON THEIR PART NUMBERS HAVING THE SAME ELECTRICAL RATINGS.

1. ALL WIRES SHALL BE MIN 18AWG PVC PER UL1015.

NOTES: UNLESS OTHERWISE SPECIFIED.

VOLTAGE: SEE TABLE	TITLE: LADDER DIAGRAM
WATTAGE: SEE TABLE	
AMPERAGE: SEE TABLE	
HERTZ: SEE TABLE	
WIRES: 2W + G	PART NUMBER: LD-ALPHAGT-30
PHASE: 1 PH	REVISION: J

ALP1GT34x/ALP2GT34x - 220-240Vac INTERNATIONAL MODEL

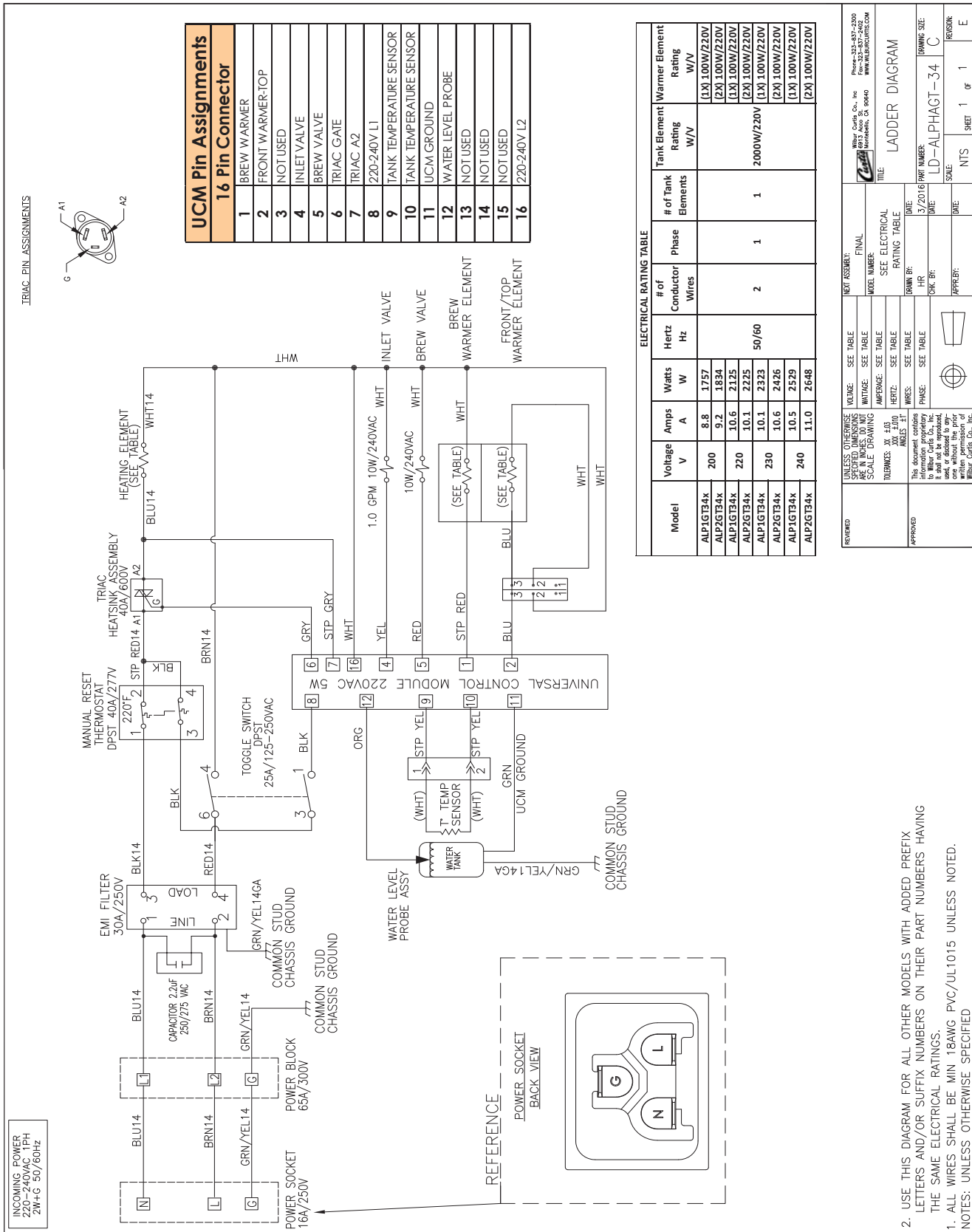

**WARNING:**

**Electric Shock Hazard** - the following procedures are to be performed only by a qualified service technician. Disconnect power when replacing components. Lock out and tag the circuit breaker on units without a power plug. Neither Wilbur Curtis Co., Inc. nor the seller can be held responsible for the interpretation of this information, or any liability in connection with its use.

**Scald and Burn Hazard** - keep body parts clear of hot surfaces during troubleshooting.



**IMPORTANT:** If it is necessary to replace the G3 universal control module (UCM), always check all inlet, dump (brew), bypass\* and dilution\* valve coils for a short and replace the valve as necessary, before replacing the module. See the *Valve Test Procedure*, below to test for defective valves. \*Some units do not have this function, see the *ELECTRICAL SCHEMATIC*.

**Troubleshooting Guidelines**

- If an error message appears on the display, consult the *ERROR CODES* section before troubleshooting.
- A brewer that is not level may not function properly. Make sure the brewer is properly leveled before proceeding.
- This troubleshooting guide identifies some, but not all, of the possible causes for common problems that can occur.
- Use this troubleshooting guide along with the appropriate *ELECTRICAL SCHEMATIC*.

**Valve Test Procedure**

Use a digital multi-meter to measure the resistance of valve coils.

Measure the resistance across the valve coil terminals with the wiring harness disconnected. Reverse the meter leads on the terminals and measure the resistance in the opposite direction. A resistance of less than 100 ohms, in either direction, indicates a shorted coil. The valve must be replaced.

If a shorted coil is not detected, test for an open coil:

- 1 Reconnect the valve terminals to the wiring harness.
- 2 Power up the brewer with the appropriate cover removed to allow access to the valve.
- 3 Run a brew cycle while monitoring the voltage at the valve coil terminals. If voltage is present on the terminals, you should hear the valve click open/closed at the moment power is applied or removed from the terminals. The inlet valve should open any time the water tank is not full. If the valve does not open, replace the valve. If voltage is not detected, first check the wiring. If the wiring is OK, replace the UCM.

**Water Not Hot Enough**

- 1 If the water heats, but is not hot enough, first check for the correct temperature setting on the control panel. Reprogram as necessary.
- 2 If the temperature setting is OK, and the actual water temperature does not match setting on the control panel, replace the temperature sensor.

**Water Heats More Slowly Than Usual**

- 1 Check for power across the terminals of the heating element(s). If power is being supplied, disconnect the heating element(s) and check for continuity. Replace a heating element if the resistance is too high (nominal resistance is 13 Ohms).
- 2 If there is no power to the heating element(s), check the wiring to any element that does not have the proper voltage across it. Also check for corroded connections anywhere between the power cord and the heating element(s).

**Dispenser Overflows During Brewing**

- 1 Check to make sure the control module (UCM) brew, bypass\* and dilution\* levels are set properly.
- 2 Check for a missing spray head. Replace as needed.
- 3 Make sure the dispenser is empty before starting the brew cycle. If not, empty it before brewing.

\*Some units do not have this function, see the *ELECTRICAL SCHEMATIC*.

**No Power - Display Not Lit**

- 1 Make sure the circuit breaker to the circuit supplying power to the brewer is not tripped and is turned on.
- 2 On brewers with a power plug, make sure it is connected to the power receptacle.
- 3 Make sure that the main power toggle switch on the back panel is turned ON.
- 4 Verify that all wires from the power cord are properly connected inside the unit. Check to make sure the wires are not burned/overheated. Loose connections can create heat. Check chassis ground.
- 5 Check to make sure power and ground are being supplied to the control module (UCM). If there is power into UCM, but display is blank, UCM is probably bad.
- 6 If there is no power into the UCM, trace the circuit back (using the wiring diagram) to the power cord to find out where power is lost. If there is power into the thermostat reset switch, but not out, see step 7.
- 7 If there is power into the thermostat reset switch, but not out, check to make sure that the water tank is not empty. If the tank is empty, the reset switch has probably opened up due to a low water level, go to *Water Tank Does Not Fill*. If there is water in the tank, but no power out, push in on the reset switch button to see if it restores power. If power is restored, check to make sure that the switch is not opening up at the wrong temperature (the switch should not open up at normal water temperatures). If there is still no power through the switch after pushing the button, replace the thermostat reset switch.

**Brewer Does Not Start When Brew Button is Pressed**

- 1 If **Brewing** appears on the display, check for faulty wiring and connections between the universal control module (UCM) and the valves.
- 2 If **Brewing** does not appear on the display, check for a faulty universal control module (UCM).

**Sensor Error Message**

This error indicates a malfunction (open circuit) in the temperature sensor system. Once the malfunction is corrected, the error message must be cleared. To reset the brewer and return to normal operation, turn the toggle switch on the back of the brewer to the OFF position for 5 seconds, then back ON.

- 1 Check the resistance across the leads of the temperature sensor while it is disconnected from the universal control module (UCM). If an open circuit is measured (resistance above 200 k), replace the sensor.
- 2 If the sensor resistance is less than 200 k check the sensor wires for corrosion and reconnect them to the UCM. Afterward, if the error message comes back after resetting the control and power modules, replace the UCM.

### Water Tank Overfills

- 1 Turn the toggle switch on the back of the brewer ON and OFF. If water continues to flow when the switch is in both positions, replace the inlet valve.
- 2 If water stops flowing to the water tank when the toggle switch is turned OFF and continues when the switch is turned back ON, remove the orange wire from the water probe on the tank. While power is ON, short the end of the orange wire to the metal surface on the outside of the tank. If the water tank stops filling when the orange wire is shorted to the tank, check for a corroded connection at the water probe.
- 3 If water does not stop flowing when the orange wire is shorted to the tank, check the tank ground connection and the continuity of the orange wire connecting to the universal control module (UCM). If both are OK, replace the UCM.

### Water Tank Does Not Fill



**IMPORTANT:** No water or low water in the tank can cause the tank to overheat, resulting in the thermostat reset switch opening. If after correcting a tank fill problem there is no power to the control panel, push the reset switch button to reset.

- 1 Check to make sure the water supply is turned on. Check for a clogged water supply line, water filter or plugged inlet valve.
- 2 If there are no plugs in the water supply line, check for power across the inlet valve terminals. If power is being supplied, but there is no water flow, replace the inlet valve.
- 3 If power is not being supplied to the inlet valve, check the wires between the universal control module (UCM) and the inlet valve. Check for corroded connections.
- 4 If the wiring between the UCM and the inlet valve is OK, but there is no power to the inlet valve, remove the orange wire from the water tank probe. If the water tank starts to fill, replace the water probe. If the water tank does not start to fill, replace the UCM.

### Coffee/Tea Too Strong

See *Dispenser Not Filled To Normal Level During Brewing*.

### Dispenser Not Filled To Normal Level During Brewing

- 1 Check to make sure that the universal control module (UCM) brew, bypass\* and dilution\* levels are set properly.
- 2 Check to make sure that the flow rate and water pressure from the water supply line meet the minimum specifications for the brewer. See the **SPECIFICATIONS** section.
- 3 Check to make sure that the spray head is clean and free of debris. Clean or replace as needed. Also make sure that the spray head is correctly aligned and that the tubing is routed properly to allow for maximum water flow (no kinks).
- 4 Remove the brew basket and place a large container under the dump (brew) and dilution outlet points. Run a brew cycle and confirm that the dump (brew) valve, bypass\* valve and dilution\* valve open during the brew cycle. Check for flow through any exit point that is slow or non-existent. Not all valves open at the same time. If flow is restricted, check for obstructions in the related tubing or valve. If there are no obstructions, but flow through one particular valve is slow, it can be assumed that the particular valve is not opening all the way and should be replaced. If water does not flow at all through a particular valve during the brew cycle, check to make sure that power is being supplied to the valve in question. Replace any valve that is not opening when power is applied to the terminals. If power is not being supplied to the valve, check the wiring between the valve and the UCM. If the wiring is OK, replace the UCM.

\*Some units do not have this function, see the **ELECTRICAL SCHEMATIC**.

**Dispenser Overflows All Of The Time**

- 1 Check to see if water continues to flow from the spray head, the bypass\* outlet or the dilution\* spout when the toggle switch is turned OFF. Replace any valve that is stuck open.  
\*Some units do not have this function, see the *ELECTRICAL SCHEMATIC*.
- 2 If one or more of the valves mentioned in step 1 turns on when the toggle switch on the back is ON and turns off when the switch is OFF, replace the universal control module (UCM).

**No Water/Tea Flows From Brewer During Brewing**

- 1 Make sure that the water supply is turned on.
- 2 Check to see if the water in the tank is level with the water tank probe? If not, see *Water Tank Does Not Fill*.
- 3 If the water tank is full, the water is hot and power is on, but NO water flows during a brew cycle, the problem is usually a bad universal control module (UCM). Run a brew cycle and check for power from the UCM to the dump (brew), bypass\* and dilution\* valves. If there is no power output, replace the UCM.  
\*Some units do not have this function, see the *ELECTRICAL SCHEMATIC*.

**Low Water Flow Warning**

See *Water Level Error Message*.

**Water Level Error Message**

Water level fill error or overflow. This error message occurs when the inlet valve solenoid has been on too long during initial fill or tank refill, See the *ERROR CODES* section for the maximum times allowed. Once the malfunction is corrected, the error message must be cleared. To reset the unit and return to normal operation, turn the toggle switch on the back of the brewer to the OFF position for 5 seconds, then back ON.

- 1 Check to make sure that the water filter is not clogged.
- 2 Check to make sure that the flow rate from the water supply line meets the minimum flow rate specifications for the brewer. Also check the water pressure. See the *SPECIFICATIONS* section.
- 3 Check for blockage at the inlet valve inlet and outlet and that it opens completely. Check for blockage in the tubing between the inlet valve and the water tank.
- 4 Check the water probe wire for an open condition or corroded connections.
- 5 If the probe connections are OK, cycle power to the unit by turning the rear toggle switch OFF, then ON. Check to see if power is applied to the inlet valve terminals. If power is applied to the terminals, but there is not water flow, replace the inlet valve.
- 6 Check for power from the universal control module (UCM) to the inlet valve. If the wiring is OK, replace the UCM.

### Water Does Not Heat At All

- Check to see if the water level in the tank is in contact with the water level probe. If not, see *Tank Does Not Fill*. The water will not heat unless it is in contact with the probe.
- If the water heats, but is not hot enough, see *Water Not Hot Enough*.
- If **Ready to brew** appears on the display, but the water is not hot, check the resistance across the leads of the temperature sensor. If the resistance is less than 10 k and the water is not hot, replace the temperature sensor. If the sensor resistance is above 10 k when the water is cool, replace the universal control module (UCM).

If **Heating...** appears on the display, but the water is not hot, follow the steps below. The following steps are performed with the rear toggle switch in the ON position.

- 1 Check for power across the terminals of the heating element(s). If power is being supplied, remove the wires and check for an open heating element.
- 2 If there is no power to the element(s), trace the circuit back (using the ELECTRICAL SCHEMATIC) to the power cord to find out where power is lost. If there is power into the triac but not out, see the following step.
- 3 If there is power into a triac, but not out, check for power at the gate terminal. Also check the wire to A2 from the UCM. If the connections are good and power is being supplied to the triac, but there is no voltage out of A2, replace the triac. If power is not being supplied from the UCM, but **Heating...** appears on the display, check the wiring from the UCM to the triac. If the wiring is OK, replace the UCM.

### Water Too Hot (Boiling or Excessive Steaming)



**IMPORTANT:** Before proceeding, make sure that the control panel temperature is adjusted to compensate for higher elevations. The factory setting is 200°F (92°C). Reduce the temperature setting 2°F (1°C) for every 1000 feet (300 m) of elevation above 4000 feet (1200 m).

- 1 If **Over Temp Sensor** or **Ready to Brew** appears on the display and the water is too hot, go to *Over Temp Sensor Error Message*.
- 2 If the display reads **Heating** constantly, first check to make sure that the temperature sensor is attached tightly to the tank and that heat sink compound was used. A properly mounted sensor should have a resistance of around 7 k when the water is hot. If not, replace the sensor.
- 3 Check to see if the universal control module (UCM) constantly has power output to the triac, regardless of the resistance of the temperature sensor. If so, the UCM is probably bad.
- 4 If the UCM is working properly, check for a bad triac.

### Over Temp Sensor Error Message

This error message indicates that the universal control module (UCM) has detected a water overheating problem. The UCM is reading a water temperature in the tank above 210°F (99°C). If the water temperature is too hot, but **Heating...** appears on the display, see *Water Too Hot*. Once the malfunction causing the error is corrected, the error message must be cleared. To reset the brewer and return to normal operation, turn the toggle switch on the back of the brewer to the OFF position for 5 seconds, then back on.

- 1 Check for power at the gate terminal on the triac. If there is no power at the triac gate terminal but the heating elements are always on, replace the triac.
- 2 Turn off power to the brewer and allow water tank to cool. Once cool, turn power back on while monitoring the triac gate voltage. During normal operation, power should be applied to the gate terminal, then drop to below 1 Vac. The universal control module (UCM) should be replaced if power is applied to the triac gate constantly even though **Ready to brew** or **Over Temp Sensor** appears on the display.
- 3 If the UCM is operating normally, check for a false over-temp error caused by the temperature sensor. Check the resistance across the leads of the temperature sensor. If the resistance is less than 10 k when the water is cool, replace the temperature sensor.

## Warmer Does Not Heat

**NOTE:** The heating element is designed to keep brewed coffee hot, but is not of sufficient wattage to reheat cold coffee.

- 1 First, check to make sure that the warmer function is not set to off in brewer program (warmers default). See the *PROGRAMMING GUIDE* section.
- 2 Turn on power to the warmer that is not working. See the *OPERATING INSTRUCTIONS* to determine how the warmer operates for your model. Check for power at the terminals of the warmer element. If power is supplied to the element terminals, but the element does not heat, replace the element.

### 3 Warmers Controlled by the Universal Control Module (UCM)

If the warmer is not receiving power, check to see if power is being supplied by the universal control module (UCM) or the universal power module (UPM), depending on the model. If there is no power out of the UCM/UPM, suspect the module. If there is power output, check the wiring harness.

### 4 Warmers Controlled by a Switch

If the warmer is not receiving power, first check for power to the switch and check the switch itself. If the switch assembly is working, check the wiring harness.

**System Fault Messages**

An error message will appear on the screen in the event of a malfunction under the following conditions:

- 1 Water level overflow. This error indicates that either there is not enough incoming water flow/pressure or a water overflow condition (unit will stop functioning).
- 2 Break in temperature control circuit.
- 3 Excess temperature in heating tank.

If any of the errors below appear on the screen, turn off the main power toggle switch and call for service.

ERROR MESSAGE	WARNING DESCRIPTION	CAUSE
Water Level Error	Fill run error/Overflow	The water inlet valve has either been open for more than 10 minutes on the initial tank fill or has been open for more than 30 seconds* in normal operation.
Sensor Error	Open Probe	Break in the temperature thermistor circuit.
Over Temp. Error	Excess Temperature	The sensor is reading that temperature in the heating tank has risen above 210°F (99°C).

\* 120 seconds for models with water tanks larger than 2 gallons.

Wilbur Curtis Co., Inc. certifies that its products are free from defects in material and workmanship under normal use. The following limited warranties and conditions apply:

- 3 years, parts and labor, from original date of purchase on digital control boards
- 2 years, parts, from original date of purchase on all other electrical components, fittings and tubing
- 1 year, labor, from original date of purchase on all other electrical components, fittings and tubing

Additionally, Wilbur Curtis Co., Inc. warrants its grinding burrs for four (4) years from the date of purchase. Stainless steel components are warranted for two (2) years from the date of purchase against leaking or pitting. Replacement parts are warranted for ninety (90) days from the date of purchase or for the remainder of the limited warranty period of the equipment in which the component is installed.

All in-warranty service calls must have prior authorization. For authorization, call the Technical Support Department at 800-995-0417. Additional conditions may apply. Go to [www.wilburcurtis.com](http://www.wilburcurtis.com) to view the full product warranty information.

## CONDITIONS & EXCEPTIONS

The warranty covers original equipment at time of purchase only. Wilbur Curtis Co., Inc., assumes no responsibility for substitute replacement parts installed on Curtis equipment that have not been purchased from Wilbur Curtis Co., Inc. Wilbur Curtis Co., Inc. will not accept any responsibility if the following conditions are not met. The warranty does not cover:

- **Adjustments and cleaning:** *The resetting of safety thermostats and circuit breakers, programming and temperature adjustments are the responsibility of the equipment owner. The owner is responsible for proper cleaning and regular maintenance of this equipment.*
- **Replacement of items subject to normal use and wear:** *This shall include, but is not limited to, spray heads, faucets, light bulbs, shear disks, "O" rings, gaskets, silicone tubing, silicone elbows, canister assemblies, whipper chambers and plates, mixing bowls, agitation assemblies and whipper propellers.*

The warranty is void under the following circumstances:

- **Improper operation of equipment:** *The equipment must be used for its designed and intended purpose and function.*
- **Improper installation of equipment:** *This equipment must be installed by a professional technician and must comply with all local electrical, mechanical and plumbing codes.*
- **Improper voltage:** *Equipment must be installed at the voltage stated on the serial plate supplied with this equipment.*
- **Improper water supply:** *This includes, but is not limited to, excessive or low water pressure and inadequate or fluctuating water flow rate.*
- **Damaged in transit:** *Equipment damaged in transit is the responsibility of the freight company and a claim should be made with the carrier.*
- **Abuse or neglect (including failure to periodically clean or remove lime accumulations):** *The manufacturer is not responsible for variation in equipment operation due to excessive lime or local water conditions. The equipment must be maintained according to the manufacturer's recommendations.*
- **Unauthorized repair or modification:** *This equipment must be serviced only by qualified service technicians, using factory specified parts to factory specifications.*
- **Modified/Missing Serial Tag:** *The serial number label (tag) must not be defaced or removed.*

**Repairs and/or Replacements** are subject to Curtis' decision that the workmanship or parts were faulty and the defects showed up under normal use. All labor shall be performed during regular working hours. Overtime charges are the responsibility of the owner. Charges incurred by delays, waiting time, or operating restrictions that hinder the service technician's ability to perform service is the responsibility of the owner of the equipment. This includes institutional and correctional facilities. Wilbur Curtis Co., Inc. will allow up to 100 miles, round trip, per in-warranty service call.

**Return Merchandise Authorization (RMA):** All claims under this warranty must be submitted to the Wilbur Curtis Technical Support Department prior to performing any repair work or return of this equipment to the factory. **All returned equipment must be properly re-packaged in the original carton and received by Curtis within 45 days following the issuance of a RMA.** No units will be accepted if they are damaged in transit due to improper packaging. **NO UNITS OR PARTS WILL BE ACCEPTED WITHOUT A RETURN MERCHANDISE AUTHORIZATION (RMA). THE RMA NUMBER MUST BE MARKED ON THE CARTON OR SHIPPING LABEL. All warranty claims must be submitted within 60 days of service. Invoices will not be processed or accepted without a RMA number. Any defective parts must be returned in order for warranty invoices to be processed and approved.** All in-warranty service calls must be performed by an authorized service agent. Call the Wilbur Curtis Technical Support Department to find an agent near you.