

WARINGTM **COMMERCIAL**

PROFESSIONAL KNIFE SHARPENER

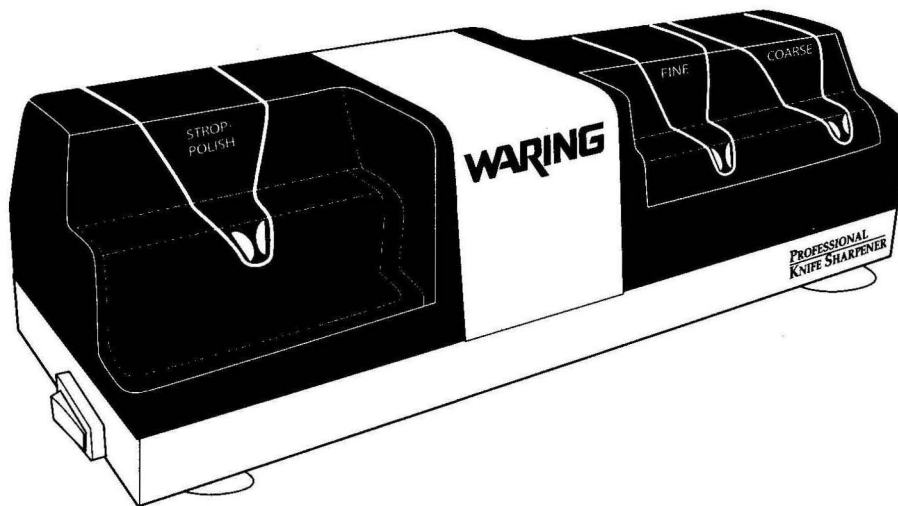

WKS800

For your safety and continued enjoyment of this product,
always read the instruction book carefully before using.

CONTENTS

Important Safeguards	1
Parts	5
Instructions for Use.....	6

IMPORTANT SAFEGUARDS

When using electrical appliances, basic safety precautions should always be followed, including the following:

- 1. READ ALL INSTRUCTIONS.**
2. To protect against risk of electrical shock, do not immerse appliance in water or other liquid.
3. Make sure that only clean knife blades are inserted into the Waring™ Commercial Professional Knife Sharpener.
4. Do not touch surfaces that may be hot.
5. Portable – unplug from outlet when not in use, before putting on or taking off parts and before cleaning. Allow to cool before handling.
6. Avoid contact with moving parts.
7. Do not operate any appliance or other electrical equipment with a damaged cord or plug, or after the unit malfunctions, or is dropped or damaged in any manner. Return it to the nearest authorized service facility for examination, repair, or adjustment.
8. This appliance is equipped with a 3-prong grounding plug and must be plugged correctly into a 3-prong grounding type wall receptacle.
9. Always check that the control is OFF before plugging cord into wall outlet. To disconnect, turn the control to OFF then remove plug from wall outlet.

10. The use of attachments not recommended or sold by Waring™ Commercial may cause fire, electric shock, or injury.
11. Do not place near a hot gas or electric burner or heated oven.
12. Do not attempt to sharpen scissors, ax blades or any other blade that does not fit freely in the slots.
13. Do not let cord hang over edge of table or counter or touch hot surfaces.
14. When in the “ON” position, the Waring™ Commercial Professional Knife Sharpener should always be on a stable countertop or table.
15. WARNING: TO AVOID INJURY USE AND HANDLE KNIVES WITH EXTREME CARE.
16. Always turn the unit on before inserting a blade and never sharpen more than one blade at a time.
17. Do not use outdoors.
18. Close supervision is necessary when any appliance is used by or near children.
19. Do not use honing oils, water, or any other lubricant with the Waring™ Commercial Professional Knife Sharpener.
20. Do not use appliance for other than intended use.

**SAVE THESE INSTRUCTIONS
FOR COMMERCIAL USE ONLY**

SHORT CORD INSTRUCTIONS

A short power-supply cord is provided to reduce the risk resulting from becoming entangled in or tripping over a longer cord.

If a longer detachable power-supply cord or extension cord is used, (1) the marked electrical rating of the extension cord should be at least as great as the electrical rating of the appliance, and (2) the longer cord should be arranged so that it will not drape over the counter top or table top where it can be pulled on by children or tripped over unintentionally.





The lightning flash with arrowhead symbol, within an equilateral triangle, is intended to alert the user to the presence of uninsulated “dangerous voltage” within the product’s enclosure that may be of sufficient magnitude to constitute a risk of fire or electric shock to persons.



The exclamation point within an equilateral triangle is intended to alert the user to the presence of important operating and maintenance (servicing) instruction in the literature accompanying the appliance.

FOR BEST RESULTS

1. Always use clean knives before sharpening or re-sharpening. If knives are soiled, wash and dry blade before sharpening.
2. Use light downward pressure when sharpening.
3. Always pull blades at a constant rate and recommended speed over length of blade. Never interrupt or stop the motion when in contact with abrasive discs.
4. Always alternate pulls in right and left slots (with exception of specialized blades which only need to be sharpened on one side).

PARTS

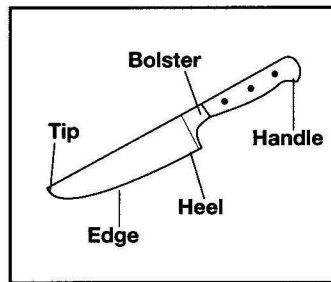
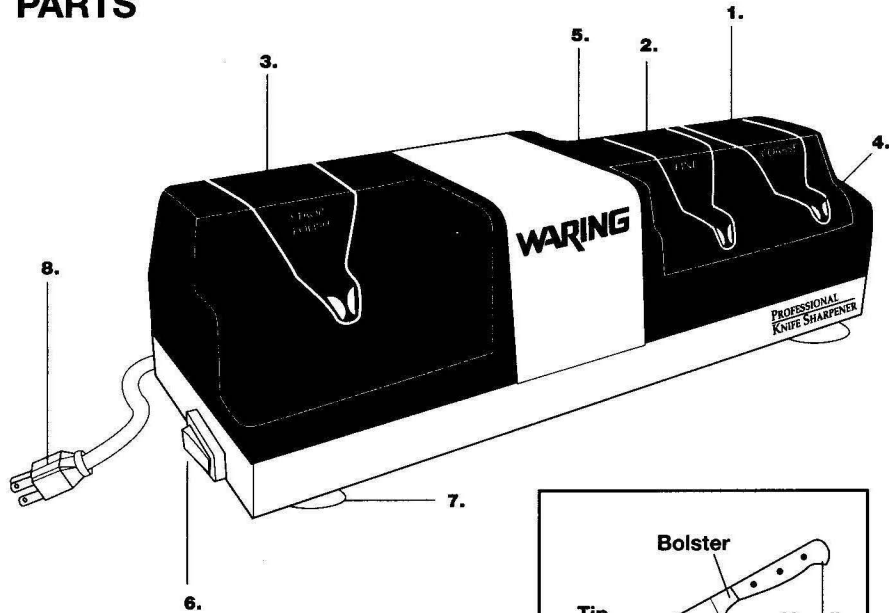

Typical Kitchen Knife

1. Coarse grinding station
2. Fine grinding station
3. Stropping/Polishing station
4. Blade guide wheels
5. Removable magnetized drawer (not shown)
6. On/Off switch
7. Suction cup feet
8. Power cord

RESETTING THERMAL PROTECTION

Your Waring™ Commercial Knife Sharpener is equipped with a thermal protection device to protect the motor from overheating. If the unit stops running under heavy use, turn the power switch off and unplug the power cord. Allow approximately 20 minutes for the motor to cool down. Plug unit back in and continue use.

INSTRUCTIONS FOR USE

Please read all instructions before you begin to sharpen.

1. Sharpen serrated blades only in the Strop/Polish station – do not sharpen serrated blades in the Coarse or Fine stations as that will remove more metal from the serrations than is necessary.
2. Straight edge blades can be sharpened using all three steps; however, use of step 1 is necessary only if the knife is very dull or damaged.

SHARPENING STRAIGHT EDGE BLADES

Plug unit in and turn the unit on. The red light will illuminate.

STEP 1 – The Coarse Grind

The Coarse grinding step is to be used when sharpening a knife for the first time or if the knife is very dull, nicked or damaged. If your knife is already sharp, you can begin with step 2, the Fine grind.

Insert the knife into right slot of Coarse grinding wheel. The knife should be positioned with the handle or bolster as close to the grinding slots as possible. The blade area closest to the handle should be positioned within the blade guide wheel. When you hear the knife make contact with the grinding wheel, slowly draw the knife toward you keeping a constant light downward pressure on the knife

without twisting. Maintain uniform contact of the blade. If the knife is curved lift the handle up as the knife tip approaches the end of the slot, keeping constant pressure on the blade contour. Sharpen the entire blade. An eight (8) inch blade should take about 4-5 seconds per pull. Pull shorter blades through in 2-3 seconds and longer blades in 6 seconds. Next, repeat with one full-length pull in the left slot of the Coarse grinding wheel. Always alternate slots after each pass in order to keep the blade edge proportionate. In step 1 you will find that only one or two pulls in each slot will be adequate. Now, proceed to step 2.

IMPORTANT: Once the blade is inserted, you should immediately begin to pull the blade toward you. Never push the blade away from you. Apply just enough pressure to make contact with the grinding wheel – added pressure is not necessary and does not improve the sharpening process.

STEP 2 – The Fine Grind

Using the same procedure described above for the Coarse grind, sharpen the blade in the Fine grinding station. Pull the blade once through the right slot and once through the left slot. As in the Coarse grind station, always alternate pulls in the right and the left slots and pull at a very steady pace. Only one or two passes on each side are necessary to attain desired sharpness. Now, proceed to step 3.

STEP 3 – Stropping/Polishing

This step will complete the sharpening process. The Strop will remove the burr from the knife blade and will polish it simultaneously. The patented reverse action is necessary to obtain a razor sharp edge. Normally, only one or two pairs of pulls in this station will be adequate to finish the process. As in steps 1 and 2 always alternate pulls in the right and left slots and pull at a very steady pace.

Additional pulls in the Strop/Polish station will hone the edge even further.

Procedure for Sharpening Serrated Blades

All types of serrated blades can be sharpened with the Waring™ Commercial Professional Knife Sharpener. USE ONLY STEP 3 (STROP/POLISH) WHEN SHARPENING A SERRATED BLADE. This will sharpen the teeth of the serrations and form small blades along the edge of these teeth. Approximately 3 to 6 pulls alternating on each side of the Strop/Polish station will be sufficient. If the knife is very dull more pulls may be necessary. If the knife's edge has been severely damaged, you can make one pull at a faster pace (2-3 seconds for an 8" blade) in each of the right and left slots of step 2 (Fine grind). Once you have done this, make a series of pulls in step 3 (Strop/Polish). Excessive use of step 2 will remove too much metal from the blade and can ruin a serrated knife.

RESHARPENING STRAIGHT EDGE BLADES

You can quickly resharpen straight edge knives with a few alternating pulls in step 3. If step 3 fails to sharpen your knife adequately, one or two pairs of alternating pulls in step 2 could suffice followed by one or two alternating pulls in step 3. You may start with step 1 if the knife has been dulled excessively.

CLEANING AND MAINTENANCE

No lubrication is needed or required for any moving parts, motor, bearings, or sharpening surfaces. There is no need for water on abrasives. The exterior of the sharpener may be cleaned by carefully wiping with damp cloth. Do not use detergents or abrasives.

Metal dust will slowly accumulate below the Coarse and Fine grinding wheels. A removable drawer can be found underneath the grinding wheels in the rear of the unit. On occasion, remove drawer and wipe with a damp cloth or paper towel. This will remove all of the metal shavings. Replace drawer.

1

Waring Commercial
Ella T. Grasso
Torrington, CT 06790

www.waringproducts.com

Printed in China

©2006
WKS800 IB
06WC30007

IB-6670