

WARING
COMMERCIAL
HL515

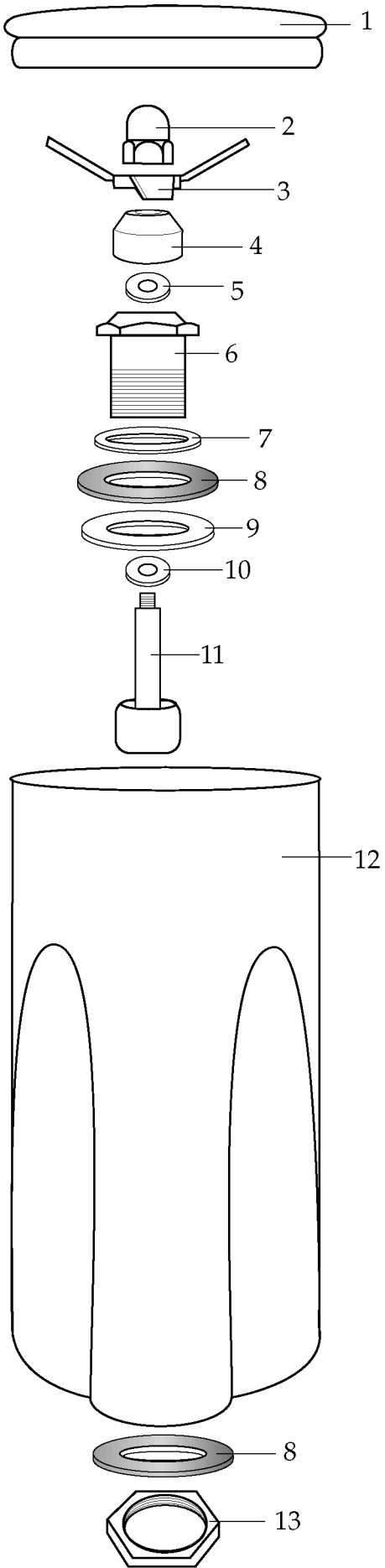

Illustration #	Part #	Description
1	003541	Stainless Steel Container Lid
2	003504	Cap Nut
3	003540	Blade
4	003503	Bearing Cap
5	005321	Washer /teflon
6	010012	Bearing Holder
7	009724	Washer /nylon
8	003537	Washer /stainless steel
9	005320	Washer /teflon
10	003510	Washer /fiber
11	003500	Drive Shaft
12	019820	Container
13	009780	Hex Nut

Electrical Continuity

With container in normal operating position, electrical resistance between the outer surface of of the container and the cap nut of the blending assembly when measured at 25 amps AC-60 HZ for 5 seconds must not exceed 0.2 OHM.

501580 Blending Assy.