



Beverage Air[®]

IMPORTANT INFORMATION

FOR
**WTR/WTF UCR/UCF
SPE/DP SERIES**

This cooler has passed the
QUALITY CONTROL INSPECTION
And meets the high standards at Beverage-Air
This inspection includes complete refrigeration
system, cabinet construction & finish.

IMPORTANT
PLEASE RETAIN FOR YOUR RECORDS

SALES OFFICE: 3779 CHAMPION BLVD., WINSTON - SALEM, S.C. 27105
PHONE: (336) 245-6400 TOLL FREE 1-800-845-9800
TECHNICAL SERVICE: 1-800-684-1199
PARTS ORDER FAX: 1-800-262-9381
CORPORATE OFFICE: WINSTON-SALEM, NC
MANUFACTURING FACILITY: BROOKVILLE, PA.

BEVERAGE-AIR

INSTALLATION AND OPERATING INSTRUCTIONS

REFRIGERATORS - DP/WTR/UCR: 46, 67, 93, 119 - SP/WTR/UCR: 20, 27, 34, 48, 60, 72

FREEZERS-UCF/WTF27A, UCF/WTF 48A

1. INSTALLATION

ILA-0800-REV. 'B'

a. Receiving Inspection

Upon receipt, check all packages for accessories or optional components, including legs, casters and shelves.

b. Door Handles

Remove door handle from bag inside cabinet and install on outside of door. The screw heads must be filled with NSF listed RTV.

c. Shelves

Shipped inside each cabinet are plastic wrapped shelves and a bag of shelf supports. Shelf spacing is adjustable to suit requirements.

d. Pilasters (SP/WTR/UCR: 20, 27, 34, 48, 60, 72)

The pilasters can be removed, without the use of tools, for cleaning.

e. Legs & Casters

Each cabinet is provided with four legs or casters shipped inside the cabinet. The legs or casters screw directly into a adapter nut provided in each corner of the base.

f. Locating Cooler

Provide at least two inches of space between cabinet rear and adjacent wall.

2. OPERATION

a. Electrical Supply and Connections

Plug all standard models into 115 volts AC 60-Hertz outlet. Low line voltage is often the cause of service complaints. Check to see that the line voltage is 110 volts or more with the unit running. Other motors or heavy appliances should not be used on the same circuit with the cooler. When working on the inside of the cooler, disconnect from electrical circuit for safety reasons. **CAUTION: If an extension cord is necessary, use only a three wire grounding type of wire size 16 AWG or larger. DO NOT exceed 20 ft. in length. The use of ungrounded cords or overload circuit voids compressor warranty.**

b. Initial Start-Up

Turn power on and check to verify that the condenser fan is running.

c. Temperature control

Factory setting of temperature control for a refrigerator is No. 5 position (normal) which will maintain the product at approximately 38°F. Factory setting for a freezer is No. 5 position (normal) which will maintain the product at approximately 0°F. For colder temperatures, turn knob clockwise one number at a time.

Excessive tampering with temperature control could lead to service difficulties. For operation above 3000-ft. altitude, have thermostat adjusted by a qualified service technician.

d. Condensate Disposal

The aluminum pan below the evaporator serves to collect and direct the condensate to the evaporator pan located below the unit. Airflow over the pan hastens condensate evaporation so that external drain plumbing is not required.

e. Freezer Defrost System

Defrost timers are factory set for (6) twenty minute defrosts per 24 hour period. The start time for defrosting should be set to occur during lightest usage of cabinet. Choose defrost time desired and turn adjusting cam until defrost is activated. Defrost will then occur every four hours. The adjusting cam is located on the face of the evaporator housing.

2. CLEANING

a. Cleaning Cabinet Exterior

Cabinets should be cleaned with a solution of mild soap and water. Do not use caustic soap or abrasive cleaners, since these might damage the cabinet finish. If stainless steel surface becomes discolored, scrub by rubbing only in the direction of the finish grain. Do not use steel wool.

b. Cleaning Interior Surfaces

The inside of the cabinet is Anodized Aluminum. To clean, use mild soapy water and cloth or sponge.

c. Condenser

For efficient operation, it is recommended that the condenser coil and fans be cleaned every 3 to 6 months. Remove rear grille for access. Vacuum clean front surface of coil thoroughly or direct forced air through condenser fins. **Failure to clean condenser can cause compressor malfunction and will void warranty.**

d. Condensate Pan

Condensate pan should be cleaned periodically to prevent odors and to maintain evaporating efficiency.

Beverage – Air Drawer Models Only

Drawer installation and removal instruction.

Drawer models are shipped to customers with drawers already installed in cabinets. Beverage air drawers are designed with the slides that have locking mechanism to prevent drawers from coming off cabinets during normal opening and closing operations.

Drawers and slides can be removed from a cabinet for cleaning purposes. To remove a drawer from a cabinet, follow these instructions –

1. Open the drawer to full extension.
2. Push the white locking tabs forward on both sides of the drawer.
3. Press down the back of the tabs.
4. Slide the drawer out of the cabinet.

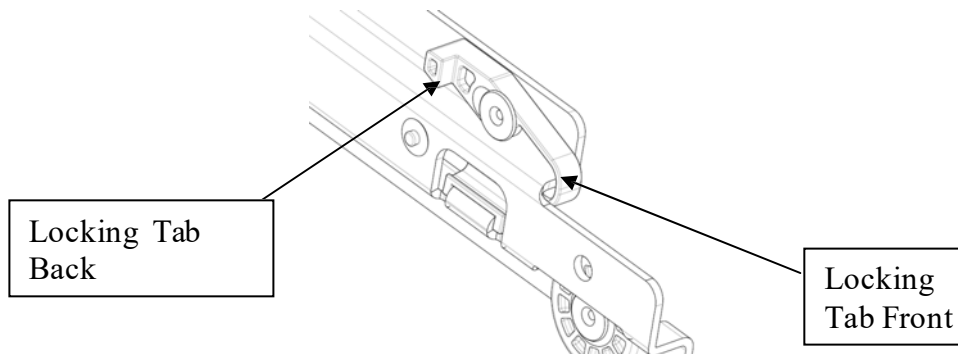

5. To remove the sliding member (middle slide), press the metal tab up and slide it out.
6. To reinstall the sliding member, press the metal tab up and slide it in.

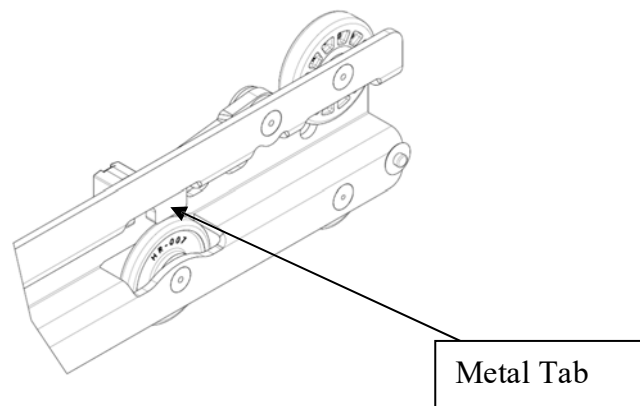

7. To reinstall drawer back, push the locking tab forward and press back of the tab down.
8. Align the drawer slide members and moving slide members.
9. Slide the drawer in and lock the slide by pushing the front of the locking tab down and in.

SHELF CLIP INSTALLATION

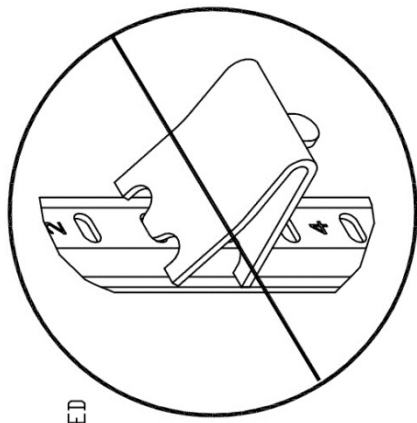
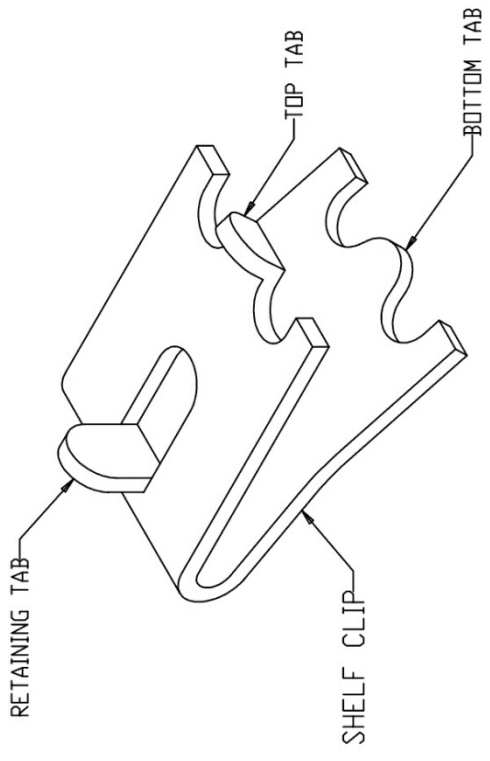

IMPROPERLY INSTALLED
CLIP (< UPSIDE DOWN >)

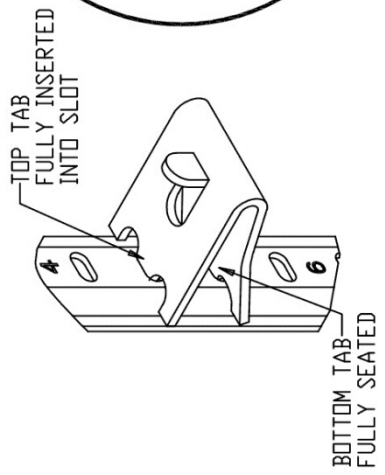

PROPERLY INSTALLED
CLIP

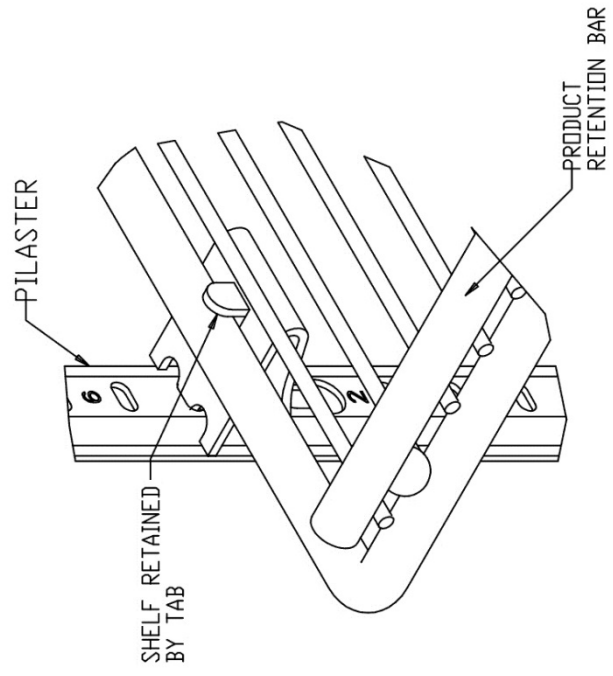

INSTALLATION INSTRUCTIONS

- 1) DETERMINE PROPER LOCATION FOR SHELF CLIPS. THE REFERENCE NUMBERS ON THE PILASTER CAN SERVE AS A GUIDE TO ENSURE ALL CLIPS ARE PROPERLY LOCATED.
- 2) INSERT TOP TAB OF THE SHELF CLIP INTO THE DESIRED HOLE OF THE PILASTER. THE RETAINING TAB SHOULD BE FACING UPWARDS AS SHOWN.
- 3) ROTATE THE CLIP DOWNWARDS AND INSERT THE BOTTOM TAB INTO THE APPROPRIATE HOLE ON THE PILASTER. THE CLIP MAY NEED TO BE SQUEEZED SLIGHTLY DURING INSTALLATION.
- 4) INSTALL ALL REMAINING CLIPS AS DESCRIBED ABOVE.
- 5) INSTALL SHELVES ONTO CLIPS WITH THE PRODUCT RETENTION BAR FACING UPWARD. BE CAREFUL NOT TO DISLodge CLIPS DURING SHELF INSTALLATION.
- 6) SHELVES MUST BE PLACED SUCH THAT THE RETAINING TAB ON THE SHELF CLIP CAPTURES THE SHELF AS SHOWN.
- 7) PRIOR TO LOADING THE SHELF, ENSURE THAT THE SHELF IS RESTING ON EACH OF 4 CLIPS AND THE CLIPS ARE INSTALLED AS SHOWN.

WARNING

- IMPROPER SHELF CLIP INSTALLATION MAY CAUSE SHELF AND/OR PRODUCT TO FALL RESULTING IN DAMAGE TO THE UNIT AND BODILY INJURY.
- DO NOT OVERLOAD THE SHELVES. THE UNIT IS DESIGNED TO UTILIZE ALL SHELVES THAT ARE SUPPLIED IN AN EQUALLY SPACED MANNER. IF LESS SHELVES OR A DIFFERENT CONFIGURATION IS DESIRED, CONTACT THE MANUFACTURER TO ENSURE SHELF OVERLOADING WILL NOT OCCUR.

SPE / UCR-UCF / WTR-WTF MODELS

REAR BUMPER INSTALLATION INSTRUCTIONS

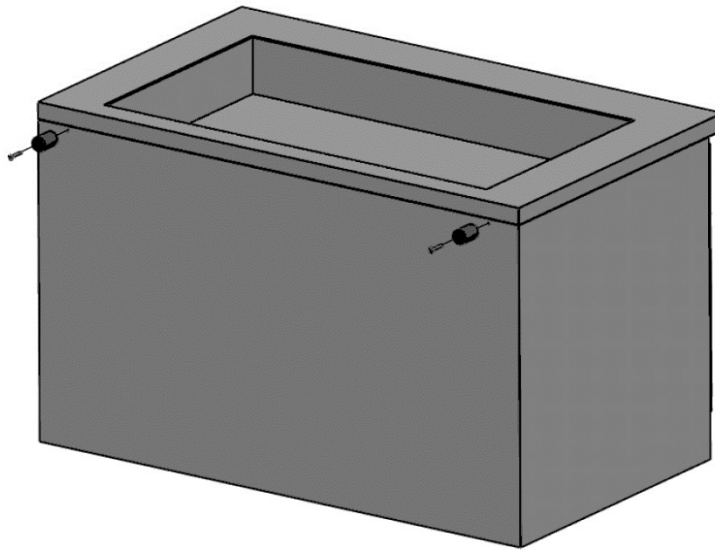

BUMPERS AND SCREWS ARE INCLUDED IN THE ZIP-LOCK BAG

1. REMOVE (1) SCREW FROM EACH END OF THE TOP REAR.
(DISCARD SCREW)
2. ATTACH THE BUMPERS AT THESE LOCATIONS, USING THE
LONGER SCREWS THAT WERE SUPPLIED.

**NOTE: FAILURE TO INSTALL BUMPERS
WILL VOID COMPRESSOR WARRANTY**

IL-2283B

SPE 60,72
EN 9872-002

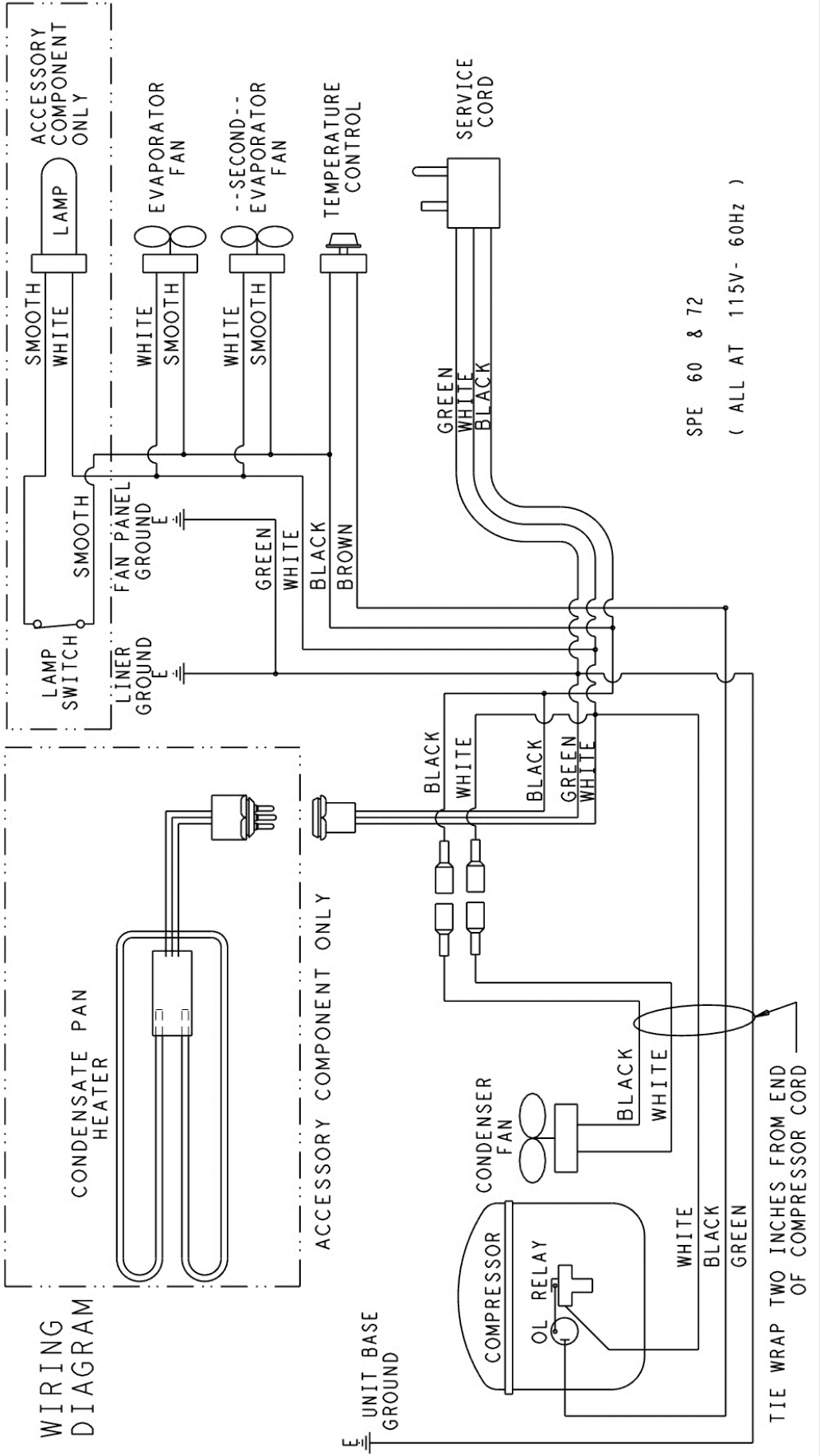
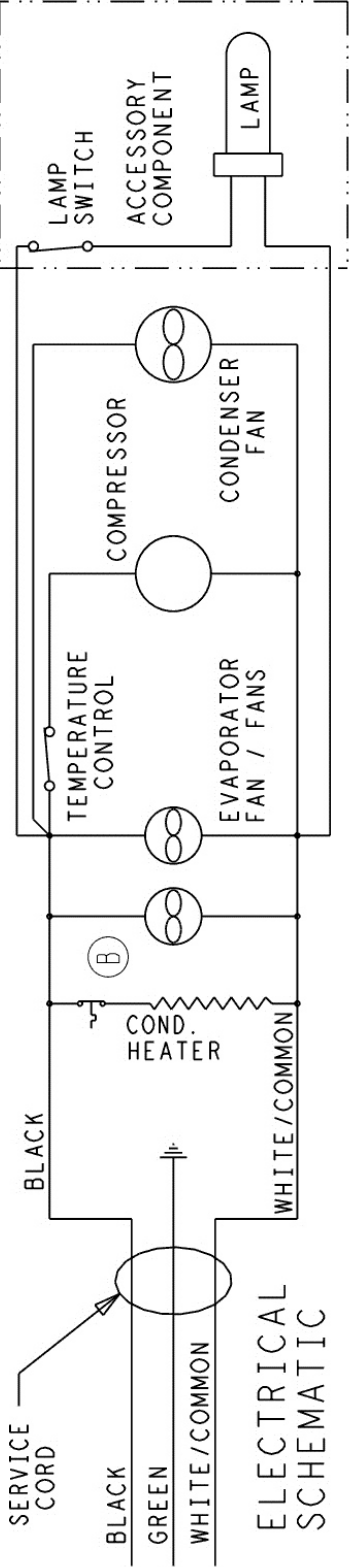

SPE 60 & 72

(ALL AT 115V- 60Hz)

IL-1792B

SPE 27,48
EN 9872-001 ; REV. E

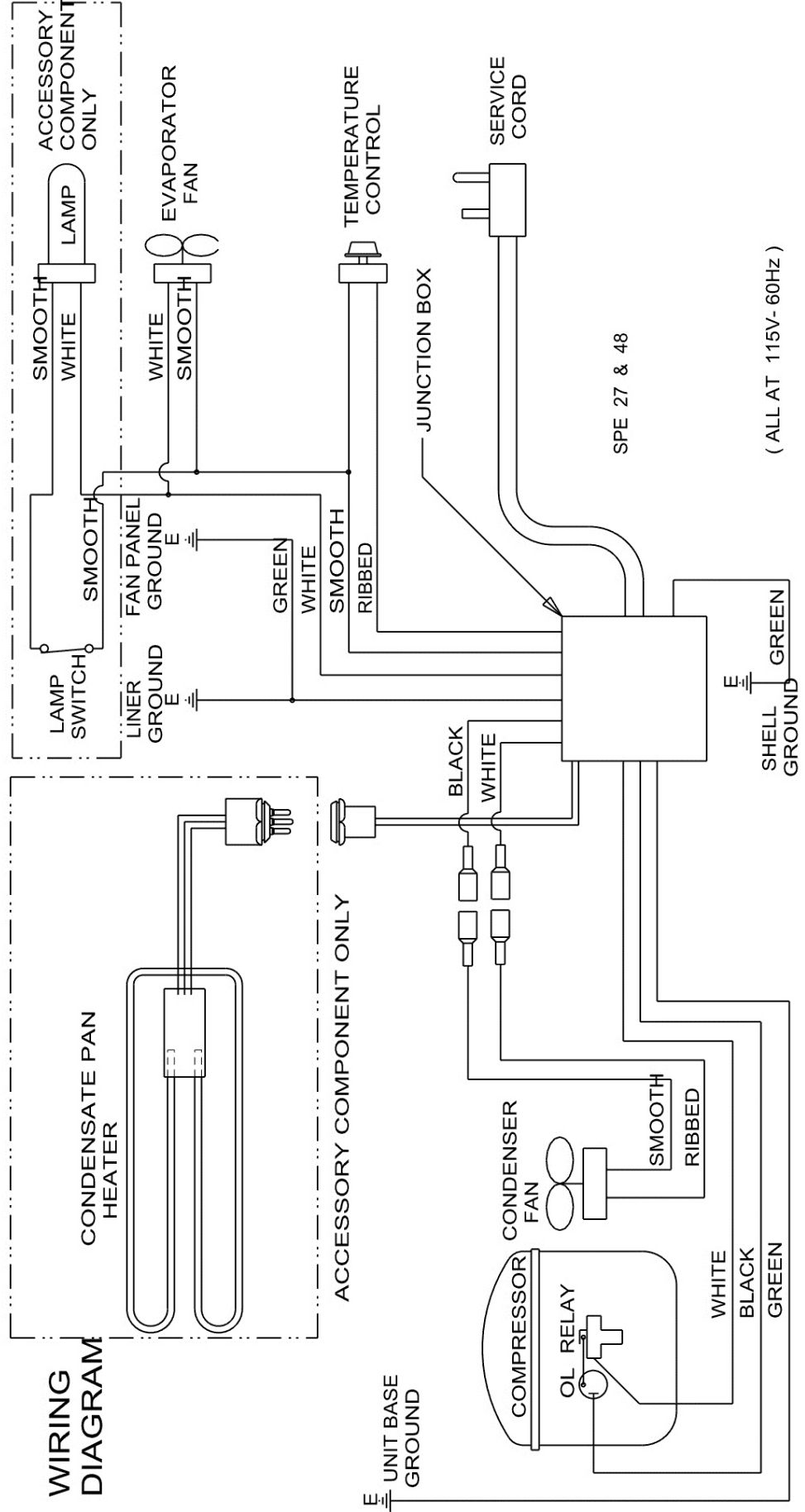
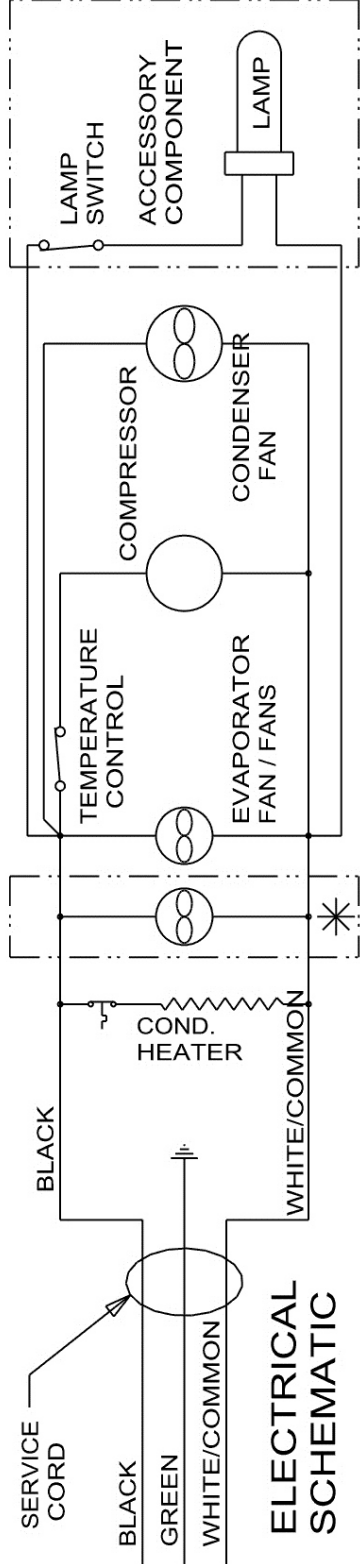

SPE 27 & 48

(ALL AT 115V- 60Hz)

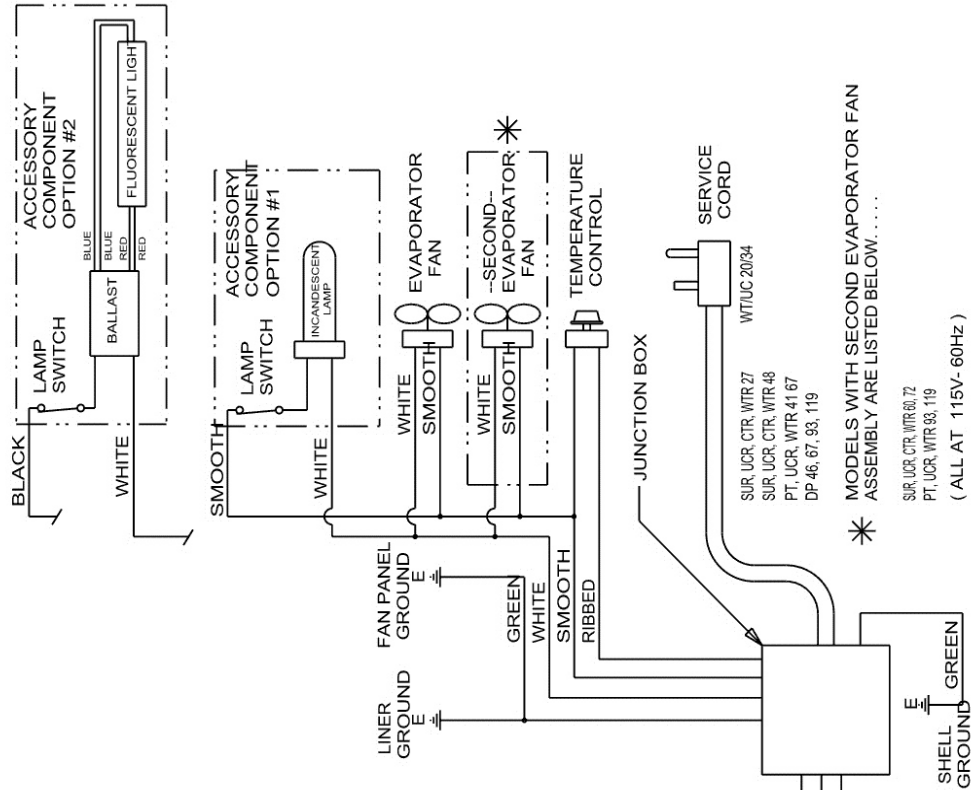
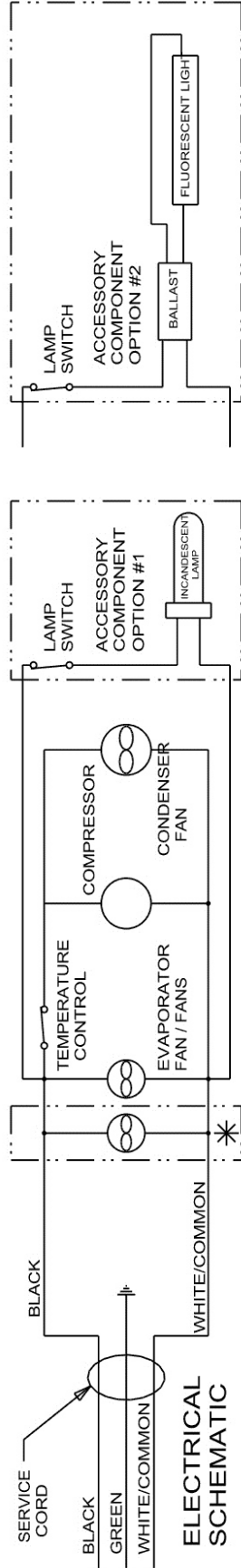

* MODELS WITH SECOND EVAPORATOR FAN ASSEMBLY ARE LISTED BELOW.

SUR. UCR. CTR. WTR 27
SUR. UCR. CTR. WTR 48
PT. UCR. WTR 41 67
DP 46, 67, 93, 119

SUR. UCR. CTR. WTR 60, 72
PT. UCR. WTR 93, 119
(ALL AT 115V- 60Hz)

**WIRING
DIAGRAM**

METHODS FOR CLEANING STAINLESS STEEL

	CLEANING AGENT*	METHOD OF APPLICATION**	EFFECT ON FINISH
Routine Cleaning	Soap, ammonia or detergent and water.	Sponge with cloth, then rinse with clear water and wipe dry.	Satisfactory for use on all finishes.
Stubborn spots and stains, baked-on splatter, and other light discoloration's.	Revere Ware cleaner, Twinkle, or Cameo stainless steel cleaner.	Apply with damp sponge or cloth. Rub with damp cloth.	Satisfactory for use on all finishes if rubbing is light. Use in direction of polish lines.
	Goddard's Stainless Steel Care, Revere Ware Stainless Steel Cleaner, Soft-Scrub.	Apply with damp sponge or cloth.	Use in direction of polish lines. May scratch or dull highly polished finishes.
	Household cleansers, such as Old Dutch, Zud, Bon Ami, Ajax, Comet	Rub with a damp cloth. May contain chlorine bleaches. Rinse thoroughly after use. Rub with a damp cloth.	
Heat tint or heavy discoloration	Revere Ware Stainless Steel Cleaner, Goddard's Stainless Steel Care.	Apply with damp sponge or cloth.	
Burnt-on foods and grease, fatty acids milkstone (where swabbing or rubbing is not practical)	Easy-Off Oven Cleaner	Apply generous coating. Allow to stand for 10 to 15 minutes. Rinse. Repeated application may be necessary.	Excellent removal. Satisfactory for use on all finishes.
Hard water spots and scale.	Vinegar	Swab or wipe with cloth. Rinse with water and dry.	Satisfactory for use on all finishes.

*Use of brand names is intended only to indicate a type of cleaner. This does not constitute an endorsement. Nor does the omission of any brand name cleaner imply its inadequacy. Many products named are regional in distribution and can be found in local supermarkets, department and hardware stores.

**It is emphasized that all products should be used in strict accordance with instructions on package.

1. Use the mildest cleaning procedure that will do the job efficiently and effectively.
2. Always rub in the direction of polish lines for maximum effectiveness and to avoid marring the surface.
3. Use only a soft cloth, sponge, fibrous brushes, plastic or stainless steel pads for cleaning and scouring.
4. Rinse thoroughly with fresh water after every cleaning operation.
5. Always wipe dry to avoid water marks.
6. **Never use common steel wool pads, these will cause rust!**

BEVERAGE-AIR

P.O. BOX 5932, Spartanburg, SC 29304-5932 Phone 800-845-9800 Fax 864-582-5083

ILA-1265 Rev B

SERVICE AND ANALYSIS CHART

REFRIGERATION SYSTEM

MALFUNCTION	POSSIBLE CAUSE	SOLUTION
Compressor will not start - no hum	<ol style="list-style-type: none"> 1. Line cord not plugged in. 2. Fuse removed or blown. 3. Overload protector tripped. 4. Temp control stuck in open position. 5. Wiring improper or loose. 	<ol style="list-style-type: none"> 1. Plug in the cord. 2. Replace fuse. 3. Refer to electrical section. 4. Repair or replace temp control. 5. Check wiring against diagram.
Compressor will not start - hums but trips on overload protector.	<ol style="list-style-type: none"> 1. Low voltage to unit 2. Relay failing to close 3. Starting capacitor defective. 4. Improperly wired. 	<ol style="list-style-type: none"> 1. Determine reason and correct 2. Determine reason and correct, replace if necessary 3. Determine reason and replace 4. Check wiring against diagram
Compressor starts but does not switch off of start winding.	<ol style="list-style-type: none"> 1. Low voltage to unit. 2. Relay failing to open. 3. Run capacitor defective 4. Comp Mt winding is open or shorted 	<ol style="list-style-type: none"> 1. Determine reason and correct. 2. Determine reason and correct, replace if necessary. 3. Determine reason and replace. * 4. Determine cause, correct, and replace comp
Compressor starts and runs, but short cycles on overload protector.	<ol style="list-style-type: none"> 1. Additional current passing through overload protector. 2. Low voltage to unit. 3. Overload protector defective. 4. Run capacitor defective. 5. Excessive discharge pressure. 6. Compressor too hot - return gas hot 	<ol style="list-style-type: none"> 1. Check wiring diagram. Check for added fan motors, pumps, etc. connected to wrong side of protector. 2. Determine reason and correct. 3. Check current, replace protector. 4. Determine reason and replace. * 5. Check ventilation, restrictions in cooling medium, restrictions in refrigeration system. * 6. Check refrigerant charge (fix leak if necessary). Check air flow across condenser.
Unit runs OK, but short cycles.	<ol style="list-style-type: none"> 1. Overload protector. 2. Cold control. 3. Overcharge. 4. Air in system. 5. Undercharge. 	<ol style="list-style-type: none"> 1. Check wiring diag for correct wiring 2. Differential set too close. * 3. Reduce refrigerant charge. * 4. Recover and recharge. * 5. Fix leak and recharge with refrigerant.
Unit operates long or continuously.	<ol style="list-style-type: none"> 1. Dirty condenser 2. Shortage of refrigerant. 3. Temp control contacts stuck or frozen 4. Evaporator coil iced. 5. Restriction in refrigeration system. 	<ol style="list-style-type: none"> * 1. Clean condenser 2. Fix leak, add charge, correct charge 3. Replace Temp control * 4. Defrost 5. Determine location and remove.
Start capacitor open, shorted or blown.	<ol style="list-style-type: none"> 1. Relay contacts not opening properly. 2. Low voltage to unit. 3. Improper relay. 	<ol style="list-style-type: none"> 1. Replace relay 2. Determine reason and correct. 3. Replace.
Run capacitor open, shorted or blown.	<ol style="list-style-type: none"> 1. Improper capacitor. 2. Excessively high line voltage (110% of rated max). 	<ol style="list-style-type: none"> 1. Determine correct size and replace. 2. Determine reason and correct.
Relay defective or burned out.	<ol style="list-style-type: none"> 1. Incorrect relay. 2. Line voltage too high or too low. 3. Relay being influenced by loose vibrating mounting. 	<ol style="list-style-type: none"> 1. Check and replace. 2. Determine reason and replace. 3. Remount rigidly.
Space temperature too high.	<ol style="list-style-type: none"> 1. Control setting too high. 2. Overcharged with refrigerant. 3. Inadequate air circulation. 	<ol style="list-style-type: none"> 1. Reset control. * 2. Recover refrigerant and recharge with proper charge specified on dataplate. 3. Improve air movement.
Cooler freezing beverage.	<ol style="list-style-type: none"> 1. Temperature control 	<ol style="list-style-type: none"> 1. Reset control.
Unit noisy.	<ol style="list-style-type: none"> 1. Loose parts or mountings. 2. Tubing rattle. 3. Bent fan blade causing vibration. 4. Fan motor bearings worn. 	<ol style="list-style-type: none"> 1. Find and tighten. 2. Reform to be free of contact. 3. Replace blade. 4. Replace motor.

ALL SERVICING MUST COMPLY WITH STATE AND FEDERAL REGULATIONS

SALES OFFICE: P.O. BOX 5932, SPARTANBURG, SOUTH CAROLINA 29304
 PLANTS: SPARTANBURG, SOUTH CAROLINA; HONEA PATH, SOUTH CAROLINA;
 BROOKVILLE, PENNSYLVANIA
 PHONE: 864-582-8111 TOLL FREE: 1-800-845-9800

- **REFRIGERATION SYSTEM**

The Refrigeration System consists of a hermetically sealed compressor and finned evaporator and condenser.

- **CONDENSER**

The condenser has wide finned spaces, which allow more air passage with less dirt or dust accumulation. The condenser still requires periodic cleaning for maximum efficiency.

- **CONDENSER FAN MOTOR**

The condenser fan motor assembly is mounted between the condenser and the compressor. Air is drawn through the condenser, over the body of the compressor and out the rear of the unit compartment.

The motor is wired to cycle with the compressor but will continue to operate should the compressor cut out on the overload. (The motor is permanently lubricated; therefore, oiling is not required).

- **DRIER**

The drier is installed in the system just before the capillary tube. Its purpose is to trap minute particles of foreign material and absorb any moisture in the system.

- **LIQUID CONTROL AND HEAT EXCHANGE**

Liquid refrigerant control to the evaporator of the system is accomplished by the use of a capillary tube. This capillary tube is soldered to the suction line to form a heat exchanger which subcools the liquid refrigerant to maintain high efficiency within the system.

REFRIGERATION SERVICE

- **EVACUATION**

Moisture in a refrigeration system is directly or indirectly the cause of more problems and complaints than all other factors combined.

When large amounts of moisture are present, system freeze ups will occur. Even in minute amounts, moisture will combine with refrigerants to form an acid. The corrosive action of this acid forms sludge, which will plug the lines and drier.

Since most field type vacuum pumps cannot pull a low enough vacuum to remove all moisture from the system, it is recommended that the system be triple evacuated, breaking each time with dry refrigerant nitrogen. Use care to purge air from the charging hose when breaking the vacuum.

- **CHARGING REFRIGERATION SYSTEM**

Since capillary tube systems have small critical refrigerant charges, we recommend that a field charge either be weighed in or put in from a portable charging cylinder. After maximum vacuum has been obtained as detailed above, attach charging cylinder to the system line making sure to purge air from hose with refrigerant. With the unit running, allow refrigerant to run slowly into the system until the desired charge is reached. When using Refrigerant Blends it is recommended to liquid charge into the high side of the system with the initial charge and then any remaining charge can be put into the suction side; however, care must be taken to meter the remaining amount into the low side so as not to cause excess liquid to go into the compressor.

OVERCHARGE

When the cabinet has pulled down to operating temperature, an indication of an overcharge is that the suction line will be cooler than normal with the compressor running. Running time will be higher than normal. Suction line will sweat or frost.

Reclaim excessive refrigerant from the system very carefully in small amounts waiting several minutes for the system to balance.

UNDERCHARGE

An undercharge or shortage of refrigerant will result in any of the following:

1. Lower than normal head pressure.
2. Lower than normal suction pressure.
3. Excessive or continuous operation of compressor.
4. Higher than normal cabinet temperature.

FEDERAL LAW REQUIRES THAT REFRIGERANTS BE RECOVERED PRIOR TO SERVICING.

