

VICTORY[®]

INSTALLATION AND OPERATING INSTRUCTIONS for all Hydrocarbon RIS and RISA Refrigerator Models



809-192A Rev D. 04/29/2025

3779 CHAMPION BLVD, WINSTON-SALEM, NC 27105

Phone: (888) 845-9800 | Fax: (800) 253-5168 | Web: victoryrefrigeration.com

**SEE BACK COVER FOR
WARRANTY REGISTRATION**

WELCOME

Thank you for purchasing a Victory cabinet. This series has passed our strict quality control inspection and meets the high standards set by Victory! You have made a quality investment that with proper maintenance will give you many years of reliable service!

Please read the following installation and maintenance instructions before installing or using your unit.

Important Information

- PLEASE READ THESE INSTRUCTIONS CAREFULLY BEFORE INSTALLING OR USING, IF RECOMMENDED PROCEDURES ARE NOT FOLLOWED, WARRANTY CLAIMS MAY BE DENIED.
- Your warranty registration information is located with this manual. Please complete the card and submit it to Victory within TEN days of installation. Failure to properly register equipment may limit or void the warranty.
- Victory reserves the right to change specifications and product design without notice. Such revisions do not entitle the buyer to corresponding changes, improvements, additions, or replacements for previously purchased equipment.

Safety	3
Important Information	5
Product Information	6
Clearance and Placement	7
Unpacking and Set Up	8
Shelf Installation.....	9
Electrical.....	10
Using The Unit.....	11
Carel Applica App	12
Sequence of Operations	14
Electronic Controller Display	15
Changing the Operating Setpoint.....	18
Alarm Codes.....	20
Cleaning and Maintenance	24
Condenser Cleaning.....	25
Methods For Cleaning Stainless Steel.....	26
Help.....	27
For The Service Tech - R290	28
For The Service Tech - Wiring Diagram.....	29
Limited Warranty	30
Limited Warranty (continued).....	31

SAFETY

This appliance has been designed with your safety in mind. It has many features to keep you from being harmed. However, safe operation and maintenance are your responsibilities.



Use: When using this unit, please:

- **Move it carefully.** If on casters be sure the casters do NOT run over the power cord.
- **Lock** the casters when in use.
- **Seek help.** This machine is heavy! Be sure to move with enough help to avoid tipping or dropping the cabinet.
- **Prevent children from playing in or on the cabinet.** Persons unable to use this product must be prevented access.
- **Follow all instructions.** There are many safety labels and directions on the unit. Heed them.
- **Watch your fingers.** There may be pinch points near the door hinges.



Maintenance

Do NOT:

- Clean a frozen evaporator with a sharp object
- Clean a dirty condenser with a sharp object.
- Store gasoline, kerosene or any other flammable material near the cabinet.

Do ALWAYS

- Use a Victory recommended technician certified to repair R290 equipment.
- Use **ONLY** Victory factory service parts. Use of non OEM parts can be dangerous because of the design changes needed to safely use R290.

Important Information to Add

Record the model number, serial number and the date of installation here for future reference. The model and serial numbers are on the unit's serial number dataplate, which is located on the left inside wall.

Model Number	
Serial Number	
Date of Installation	
Purchased From	



Observe the **Caution** and **Warning** notices. They are indicators of important safety information. Keep this manual for future reference.

SAFETY



CAUTION: If it is necessary to move the Refrigerator after removal from the skid, remove all doors and carefully push the unit at a point of no more than 36" from the bottom to avoid damage.



IMPORTANT INFORMATION

This unit is intended to be used in a commercial application. That includes bars and restaurants.

If installed in a residence some commercial service companies may not be able to service it on site.

The manufacturer has designed and produced this machine with the finest in materials. The manufacturer assumes no liability for units that have been altered in any way. Alterations or part substitutions will void the warranty.

Limitations

The machine is designed for use indoors in a controlled environment. It must be kept dry, not overheated or subjected to excessive cold. May only be connected to a dedicated electrical circuit. Extension cords are not permitted.

	Minimum	Maximum
Voltage	103.5	126.5
Room Air Temp	60° F	100° F

Air Flow, All Models regardless of section, door count or door material.

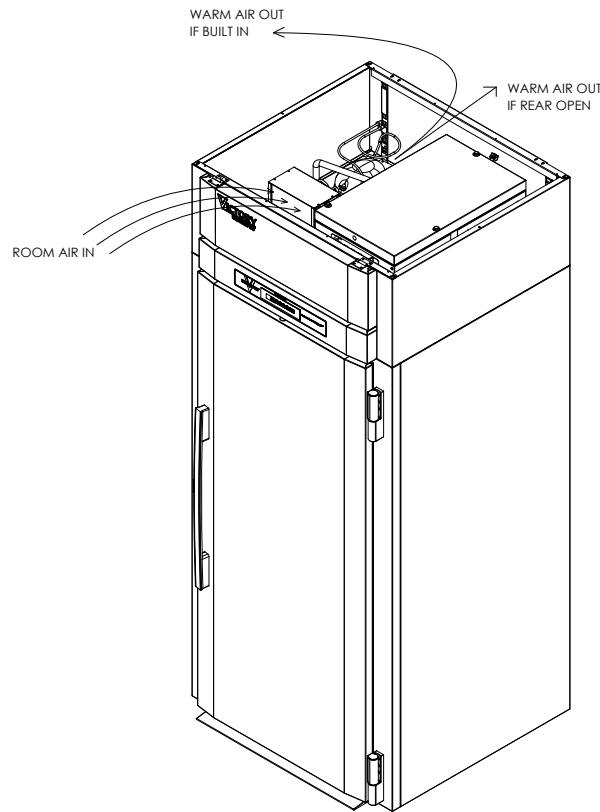

Agency Approvals

These marks appear on the dataplate or serial tag, located in the inside of the left wall. The dataplate also contains the model and serial numbers as well as electrical requirements.



PRODUCT INFORMATION

Model	Cabinet Dimensions w x d x h (Inches)	Sections	Glass or Solid Door	Full Load Amps	Refrigerant Type / Charge (g) / Charge (oz)
RIS(A)-1D-S1-HC	36 1/2 X 36 3/8 X 84 1/2	1	Solid	6.5	R-290 / 130 / 4.59
RIS(A)-1D-S1-G-HC	36 1/2 x 36 3/8 x 84 1/2		Glass		
RIS(A)-1D-S1-PT-HC	36 1/2 X 40 1/8 X 84 1/2		Solid	8.5	
RIS(A)-1D-S1-PT-G-HC	36 1/2 X 37 3/8 X 84 1/2		Glass		
RIS(A)-1D-S1-XH-HC	36 1/2 X 36 1/4 X 90		Solid	6.5	
RIS(A)-1D-S1-XH-G-HC	36 1/2 X 35 X 90		Glass		
RIS(A)-1D-S1-PT-XH-HC	36 1/2 X 39 7/8 X 90		Solid	8.5	
RIS(A)-1D-S1-PT-XH-G-HC	36 1/2 X 37 3/8 X 90		Glass		
RIS(A)-2D-S1-HC	68 7/8 X 36 5/8 X 84 1/2	2	Solid	8.5	
RIS(A)-2D-S1-G-HC	68 7/8 X 35 1/4 X 84 1/2		Glass		
RIS(A)-2D-S1-PT-HC	68 3/4 X 40 X 84 1/2		Solid	10.8	
RIS(A)-2D-S1-PT-G-HC*	68 3/4 X 37 3/8 X 84 1/2		Glass		
RIS(A)-2D-S1-XH-HC	68 7/8 X 36 5/8 X 90		Solid	8.5	
RIS(A)-2D-S1-XH-G-HC	68 7/8 X 35 1/4 X 90		Glass		
RIS(A)-2D-S1-PT-XH-HC	68 7/8 X 40 X 90		Solid	10.8	
RIS(A)-2D-S1-PT-XH-G-HC*	68 7/8 X 37 3/8 X 90		Glass		
RISA(A)-3D-S1-HC*	101 1/4 X 36 3/8 X 84 3/8	3	Solid	10.8	R-290 / 150 / 5.3
RIS(A)-3D-S1-G-HC*	101 1/4 X 34 7/8 X 84 3/8		Glass		
RIS(A)-3D-S1-PT-HC*	101 1/4 X 40 1/8 X 84 3/8		Solid		
RIS(A)-3D-S1-PT-G-HC*	101 1/4 X 37 3/8 X 84 3/8		Glass		

RIS models have stainless steel liners; RISA models have aluminum liners.

* These models have two refrigeration systems, charge numbers are for each system.

- All models will maintain product temperature between 36 and 38 degrees F. at the factory setting of 38.ºF.
- All models are 115 volts, 60 Hz AC, and are equipped with a NEMA 5-15P plug.
- ALWAYS REFERENCE YOUR EQUIPMENT DATA PLATE AMPS, REFRIGERANT AND REFRIGERANT CHARGE FOR THE MOST UP TO DATE AND ACCURATE VALUES.
- There are no access valves on the refrigeration system.
- Ultra Glass doors are optional - for full Ultra Glass Doors change G to UG, for Ultra Glass half doors, change HG to HD-UG.

CLEARANCE AND PLACEMENT

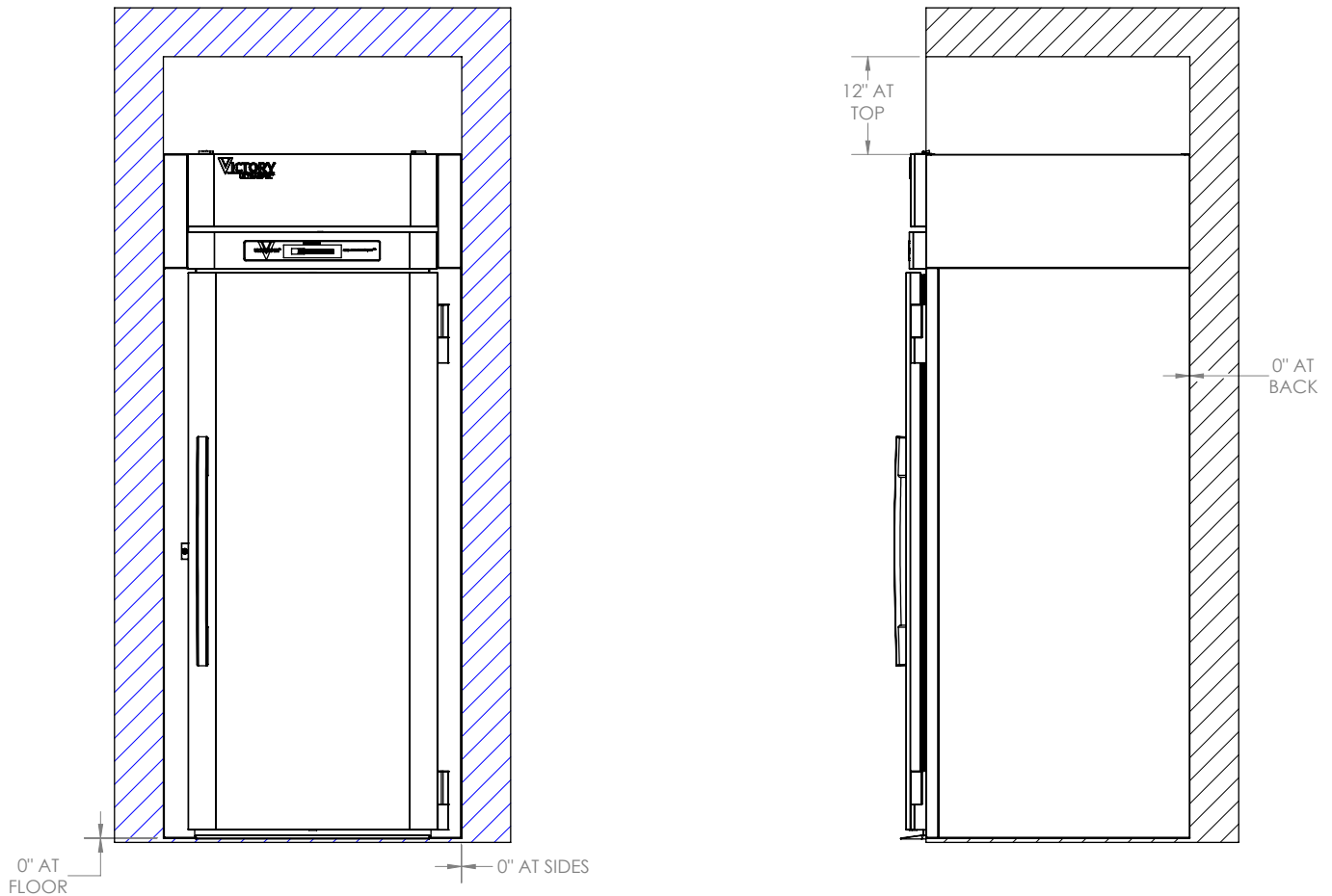

Placement

Consider the following when selecting a location for your Refrigerator:

Clearance:

- 12 in. at the top
- 0.0 in. at the rear,
- 0.0 in. at the left side
- 0.0 in. at the right side

Floor Load: The floor on which the Refrigerator is located must be even and level, free from vibrations, and strong enough to support the combined weights of the unit and maximum product load.

Ventilation: Grille area at front must be free and clear of any object or wall.

Power Outlet: Dedicated power outlet is located within the length of the unit's power cord.

UNPACKING AND SET UP

Carefully inspect the shipping carton for damage. This is the only time that shipping damage may be claimed. If damage is suspected, open the carton immediately and, if there is damage, retain the carton and contact the shipper to make a claim. Do NOT contact the manufacturer.

Uncrating

Tools Needed: $\frac{3}{4}$ " box wrench, adjustable wrench, level, flat head screw driver, and box cutter.

1. Remove the cardboard top capping, all clear tape, and all staples including those at the bottom of the cardboard carton and skid.
2. Start from the top of the carton. Using the box cutter, carefully make one continuous cut to the bottom of the skid. Remove cardboard carton and discard.

3. Move unit as close to final position as possible before removing the skid.

Do NOT tip unit on its front or sides. If tipped onto the back, unit must not be started for 3 hours.

Note: additional clear plastic protective wrap is applied directly to any product with a glass door.

Skid Removal

Tip the unit forward and remove the skid.



1. Remove the shipping bolts using the $\frac{3}{4}$ " box wrench while cabinet is held in one direction.
2. Repeat the process while the cabinet is held in the opposite direction.

Leveling

Cabinets must be leveled when installed. Level should be measured on the headrail.

Failure to level your cabinet may result in door not sealing, closing correctly, or condensed water not draining properly.

There are NO features in the Roll Thru cabinet for leveling, The cabinet must be placed on a level surface.

SHELF INSTALLATION

1. Determine the proper location for the shelf clips.
2. Insert the top tab of the shelf clip into the desired hole of the pilaster. The retaining tab **MUST** be facing up as shown.
3. Rotate the clip downwards and insert the bottom tab into the matching hole in the pilaster. The clip may need to be squeezed slightly during installation.
4. Install all remaining clips.
5. Install shelves onto clips with the product retention bar facing up. Be careful not to dislodge clips during installation.
6. Place shelves so that the retaining tab on the clip captures the shelf as shown.
7. Confirm that the shelf is resting on ALL 4 clips and that the clips are securely attached to the pilasters.
8. Improper shelf clip installation could cause the shelf and / or the product on it to fall, resulting in damage to the unit and possible bodily injury.
9. Do NOT overload the shelves. The unit is designed to use all shelves that are supplied in an equally spaced manner. Contact Victory customer service if fewer shelves or a different configuration to ensure shelf overloading will not occur.

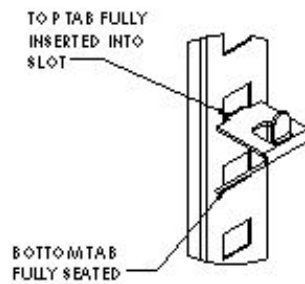
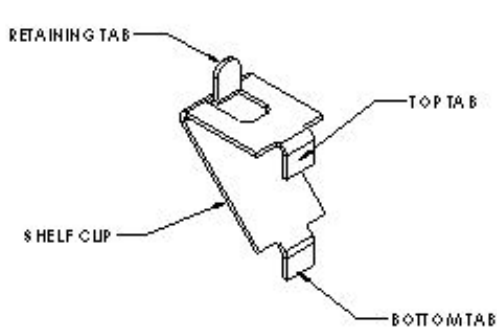

PROPERLY INSTALLED CLIP

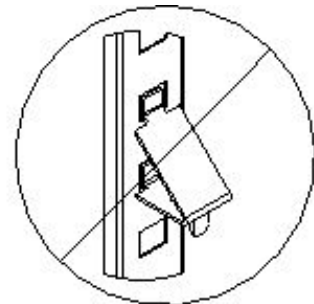

IMPROPERLY INSTALLED CLIP (UPSIDE DOWN)

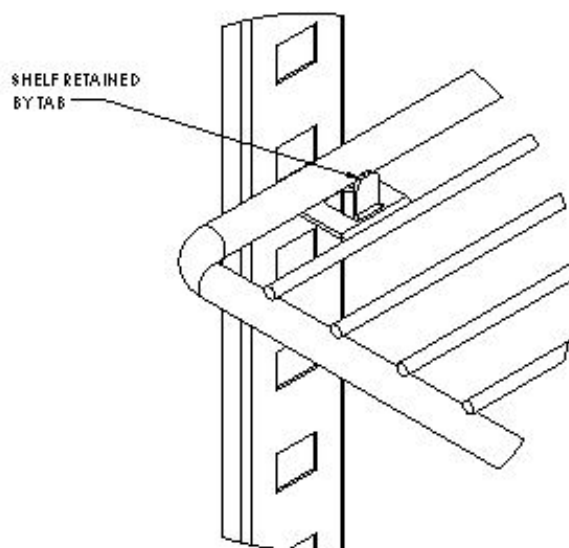

ELECTRICAL

This is a cord-connected unit, and must be connected to its own **dedicated** power supply. Check the dataplate on the machine to confirm the voltage and per the dataplate use the correct fuses or HACR circuit breakers.

Power Cord

This 115 volt model is equipped with a cord and 5-15P plug.

If the power cord becomes damaged, it must be replaced with the identical cord.

GFCI

Units that utilize variable speed compressor technology can experience nuisance tripping on Class A GFCI outlets which have a trip limit of 4 to 6 mA. To avoid this issue in a location that requires GFCI circuit protection, Victory recommends using either an Eaton, SGF20, or HUBBELL Model Number GFRST83W 20A Heavy Duty Hospital Grade Self-Test GFCI Receptacle.

Follow All National and Local Codes

This unit must be grounded. Do not use extension cords and do not disable or by-pass ground prong on electrical plug.

Initial Start Up

Plug the power cord into the proper power supply.

The cabinet will soon begin to blow warm air out of the top area, and cool air will flow from the inside blower.

The cabinet temperature has been set at the factory and should not need adjustment, however if it was changed, the standard setting is 38° F.

Cautions

Care must be taken whenever moving or servicing the unit. The refrigerant is contained in a sealed system, but if released it may be flammable.

After the cabinet has been installed, leveled, and cleaned as described above, refer to the following checklist:

- Check for proper electrical hook-up.
- Cabinet **MUST NOT SHARE A RECEPTACLE** with another piece of equipment
- Check that all clearances are in line with the aforementioned guidelines.
- Check that cabinet is level.

* **NOTE:** Once the unit has been started and reaches proper storage temperatures, it may be loaded with product. For proper energy efficiency and airflow we recommend a minimum 1" clearance between product and side walls, 4" clearance between product and ceiling, and 1" clearance from the bottom of the unit.

USING THE UNIT

Operation is simple, just keep it connected to the correct power supply and the refrigerator will maintain the internal temperature it has been set to. Keep the doors and / or drawers closed as much as possible to avoid unnecessary run time.

The controller displays the current internal temperature.

Adjusting the set temperature lower will NOT cause the system to lower the temperature faster. When on, the refrigeration system is always operating at maximum.

The temperature was set at the factory at 38° F, but you can adjust it to your own selected temperature. See pages 18 & 19.

The Refrigerator will automatically defrost as needed, there is no set time for defrost. Push and immediately release the "melting" or defrost button for a manual defrost.

The internal fan will be on when the compressor is on and when the doors are closed.

The compressor and condenser fan motor will only be on when the controller senses an increase in internal cabinet temperature passed the set point.

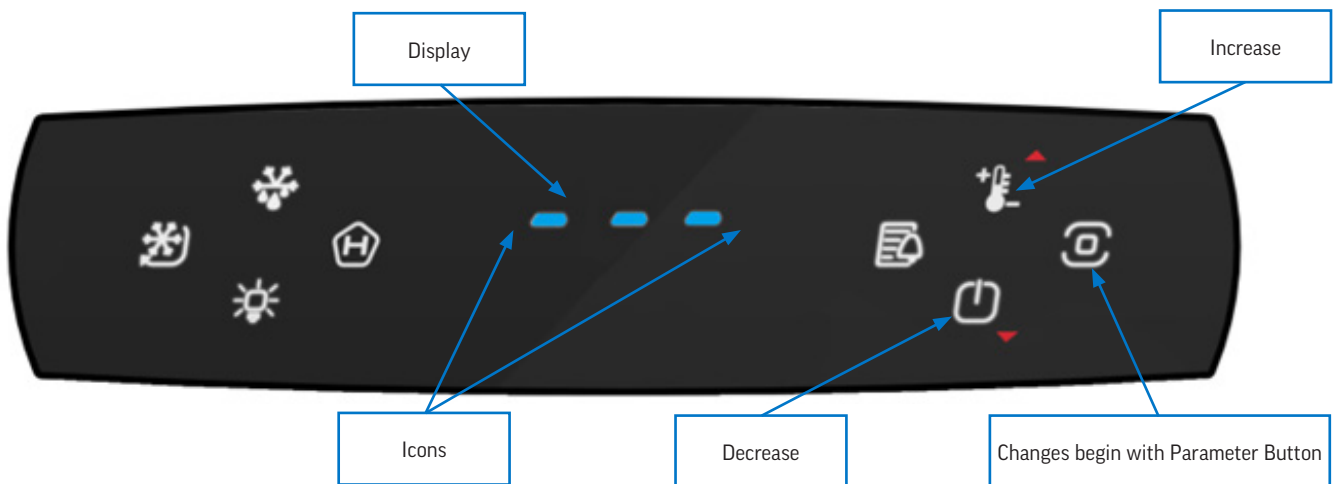

CAREL APPLICA APP

ACCESSING THE CONTROL VIA SMARTPHONE OR TABLET

Download the Carel **APPLICA** app through the App Store or Google Play Store to access the control via Bluetooth.

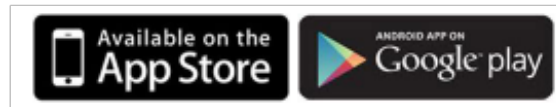

Open the app and select “Bluetooth” to search for your device. Select the Carel device that appears on the screen and wait for the control to connect.

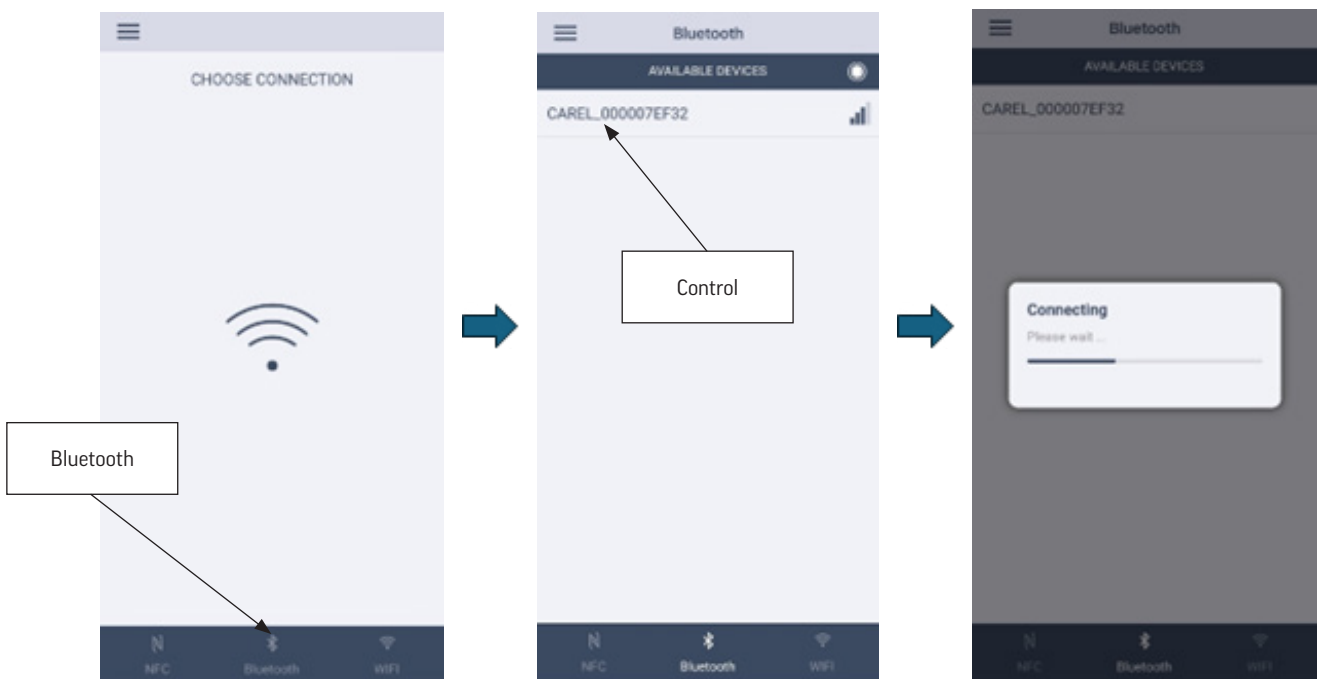



Select the "User" profile and type in the password: 0 and press "Ok".

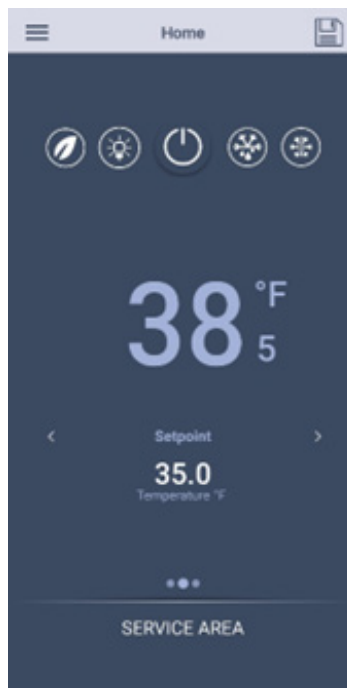

Arrive at the home page for the Applica App.



SEQUENCE OF OPERATIONS







COMPONENT	ON		OFF	
	OPERATION	CONTROLLER ACTION	OPERATION	CONTROLLER ACTION
COMPRESSOR	Compressor turns on when the cabinet temperature is above the sum of the set point and the dead band	The Compressor Contact is energized	Compressor turns off when the cabinet temperature is equal to or less than the set point	The Compressor Contact is de-energized
		IJF terminals N05, C5		IJF terminals N05, C5
CONDENSER FAN	The Condenser Fan turns on when the Compressor is running	The Condenser Fan is wired to the Compressor Relay on control	The Condenser Fan turns off when the Compressor is not running	The Condenser Fan is wired directly to the Compressor Control Relay
		IJF terminals N05, C5		IJF terminals N05, C5
EVAPORATOR FAN	The Evaporator Fan runs continuously except on door opening.	The Evaporator Fan Control contact is energized.	The Evaporator Fan turns off for 1 minute when the door is opened	The Evaporator Fan Control contact is de-energized
		IJF terminals N04, C3		IJF terminals N04, C3
LIGHT	The light will turn on when the door is open, or the light button is pressed 	The Light Control Contact is energized	The light will turn off when the door is closed, or the light button is pressed 	The Light Control Contact is de-energized
		IJF terminals N03, C3		IJF terminals N03, C3
FACE HEATER	Face Heater is on when condensing unit is on	Heater is wired with the compressor relay	The Face Heater is off when condensing unit is off	Heater is wired with the compressor relay

CONDITION	COMPRESSOR	CONDENSER FAN	EVAPORATOR FAN	LIGHTS
CABINET TEMP > SET POINT + DEAD BAND	ON	ON	ON	ON or OFF
CABINET TEMPERATURE <= SET POINT	OFF	OFF	ON	ON or OFF
DEFROST	OFF	OFF	ON	ON or OFF

ELECTRONIC CONTROLLER DISPLAY



CONTROL PANEL INDICATORS

	Auxiliary Output	Active
	Compressor	Active
	Evaporator Fan	Active
	°C	Unit of Measure °C
	°F	Unit of Measure °F
	Service Maintenance	Active Alarms

CONTROL PANEL CONNECTIONS

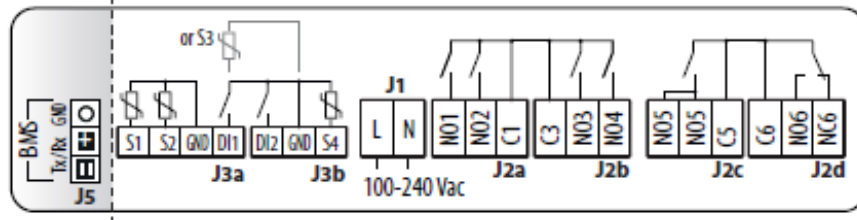



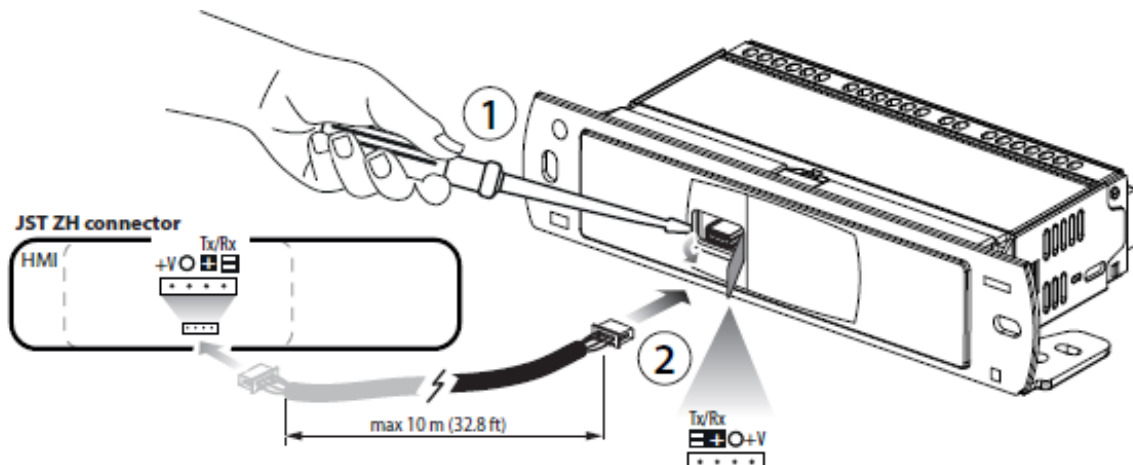

Relay/Probe	Description	Terminal
NO1	NOT USED	NO1, C1
NO2	NOT USED (EXTERNAL ALARM)	NO2, C1
NO3	LIGHT	NO3, C3
NO4	EVAPORATOR FAN	NO4, C3
NO5	COMPRESSOR	NO5, C5
NO6	DEFROST ELEMENT	NO6, C6
NC6	NOT USED	NC6, C6
S1	AIR/CONTROL PROBE	S1, GND
S2	EVAPORATOR/DEFROST PROBE 1	S2, GND
DI1	DIGITAL INPUT/DOOR SWITCH	DI1, GND
DI2	NOT USED	DI2, GND
S4	EVAPORATOR/DEFROST PROBE 2	S4, GND





DISPLAY CONNECTION



KEYBOARD FUNCTIONS

Note: Keypad has a 3 second lock feature. Press and hold the program button for 3 secs to unlock. All icons will appear when keypad is unlocked

<p>CONTINUOUS CYCLE Press and Release Activate/Stop Continuous Cycle mode</p> 	<p>DEFROST Press and Release Activate/Stop Defrost</p> 	<p>HACCP Press and Release View HACCP alarms and HACCP menu</p> 	<p>LIGHT Press and Release Toggle light on and off</p> 
---	--	--	--

<p>ALARM LOG Press and Release View active alarms and alarm menu</p> 	<p>SET/ UP Press and Release Quickly access setpoint adjustment. Scrolls menus and increases values</p> 	<p>PROGRAM (ENTER) Press and Release Used as enter button. Saves Parameter Value Press and Hold (3s) Take the control out of standby. Return to previous parameter</p> 	<p>POWER/ DOWN Press and Release Switch unit on and off. Scrolls menus and decreases values</p> 
--	---	---	---

CHANGING THE OPERATING SETPOINT - CONTROL PANEL

To change the operating set point, press and hold the parameter button for three seconds until the other buttons appear.



Press and release the set button to view the setpoint.

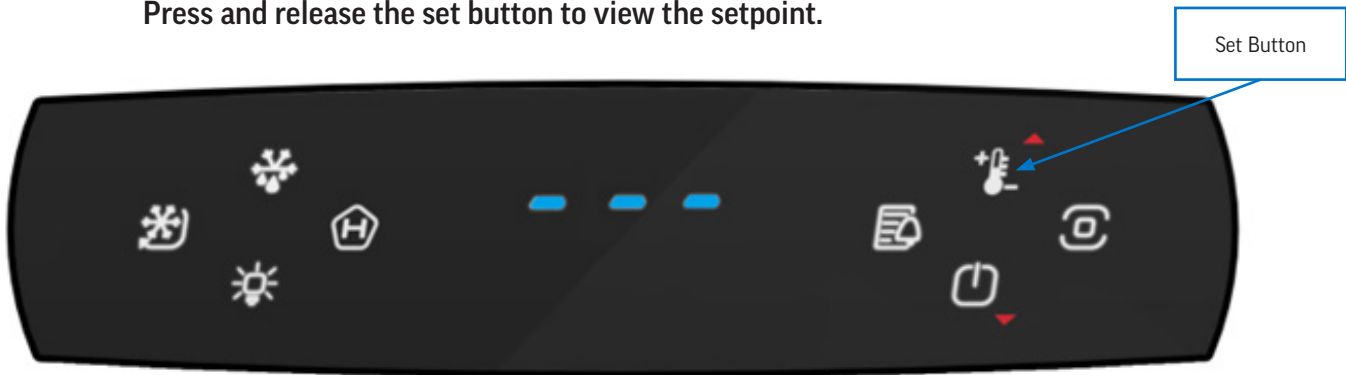

Use the up and down button to change the setpoint. When adjustment is finished, press and release the parameter button to save the change.

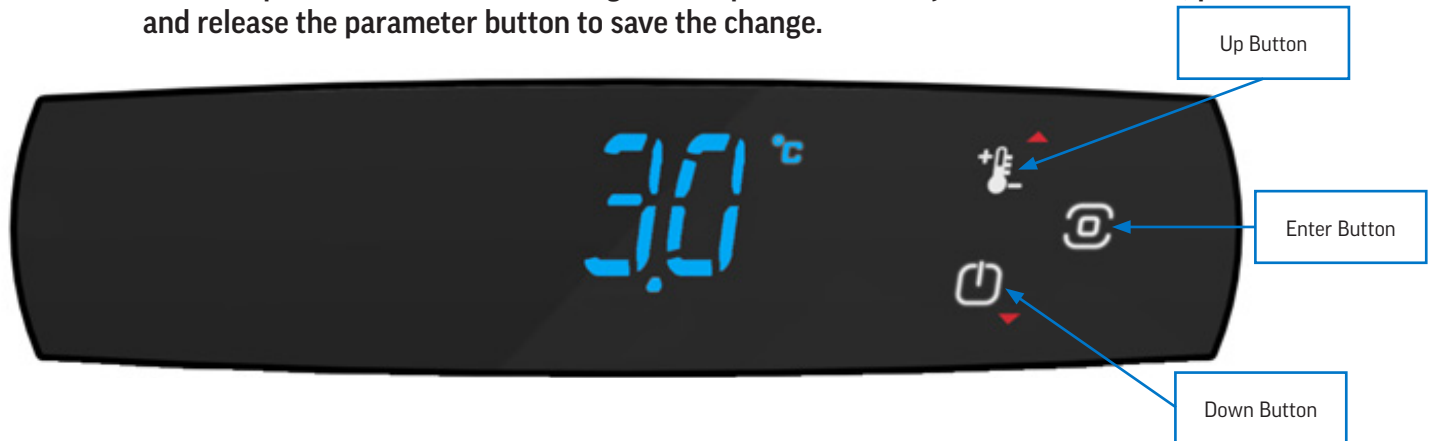

CHANGING THE OPERATING SETPOINT - CAREL APPLICA APP

Open the menu and go to the parameter list.

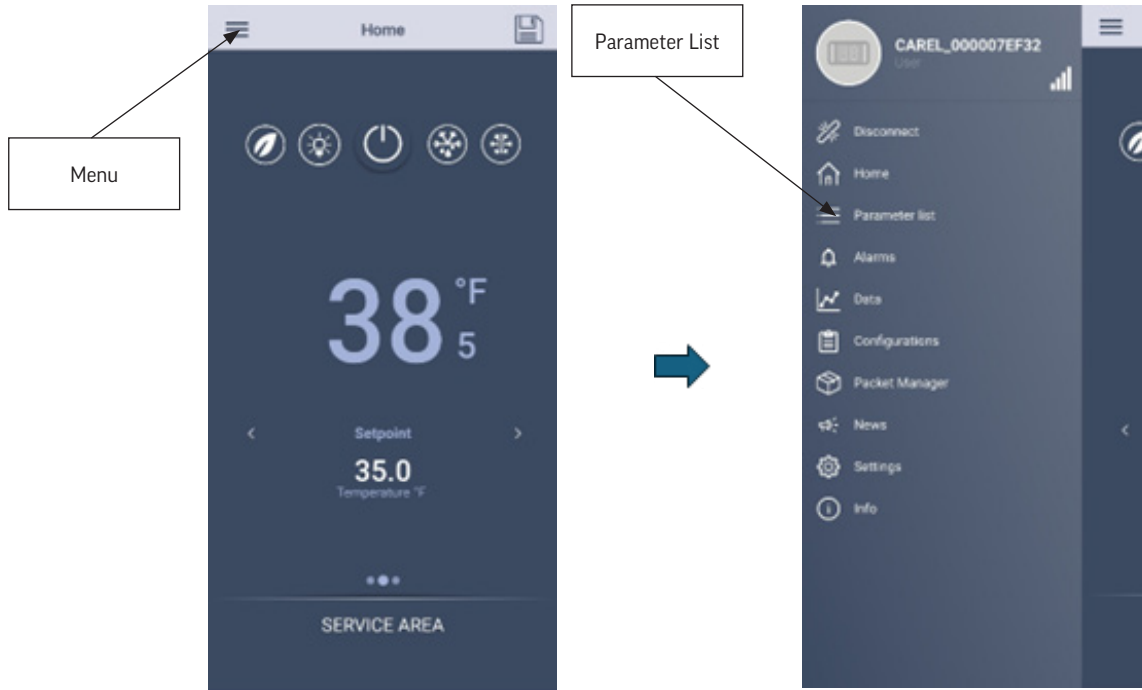

Scroll across the parameter tags and find the one labeled "Temperature Regulation". Select it and change the Setpoint (St).

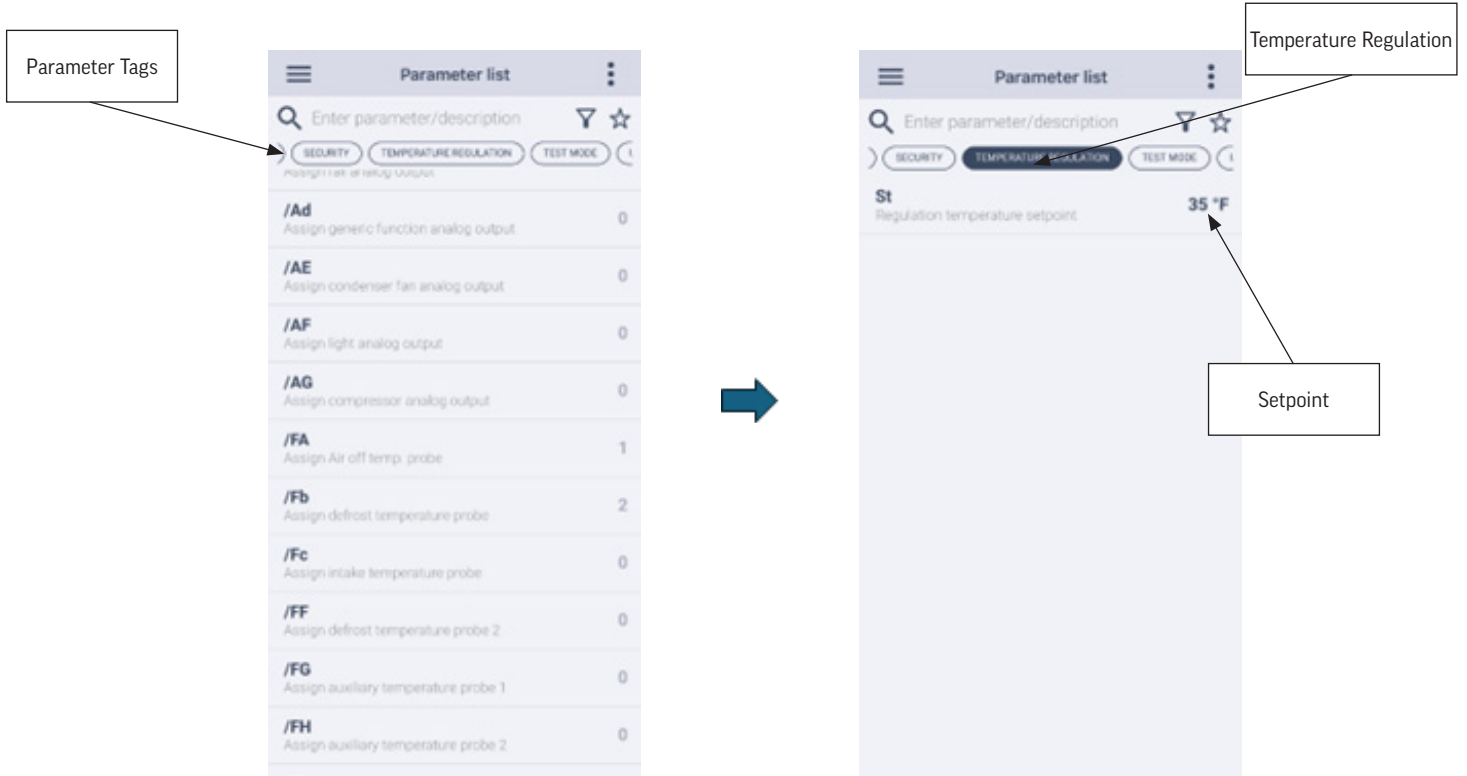

VIEWING ALARM CODES - CONTROL PANEL

To view the alarm codes, press and hold the parameter button for three seconds until the other buttons appear.



Press and release the alarm log button to view the alarm codes.

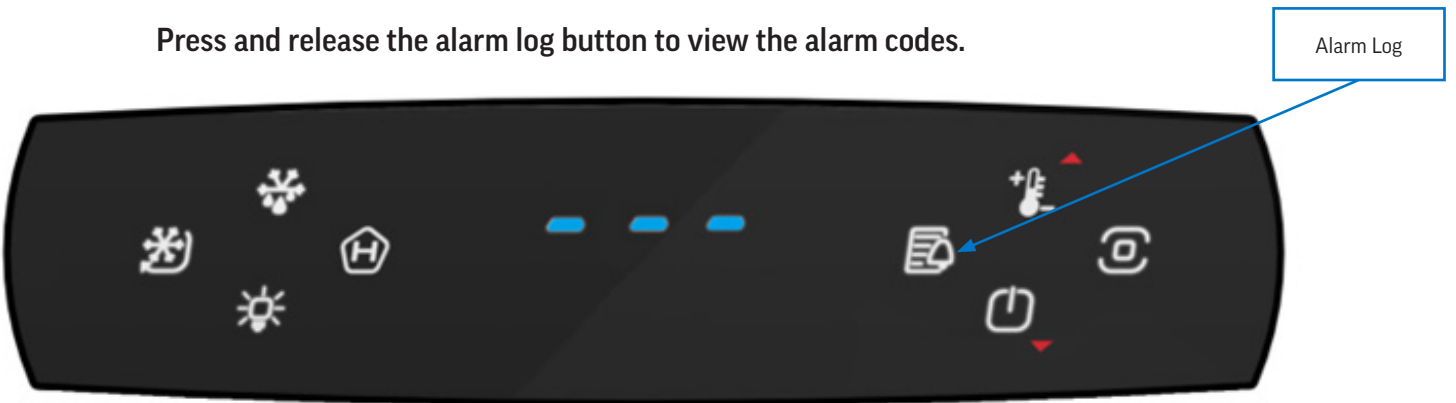

Use the arrows to scroll through the alarm code.



Scroll to "ESC" and press the enter button to exit the alarm log.



VIEWING ALARM CODES - CAREL APPLICA APP

Open the menu and open to the alarms page

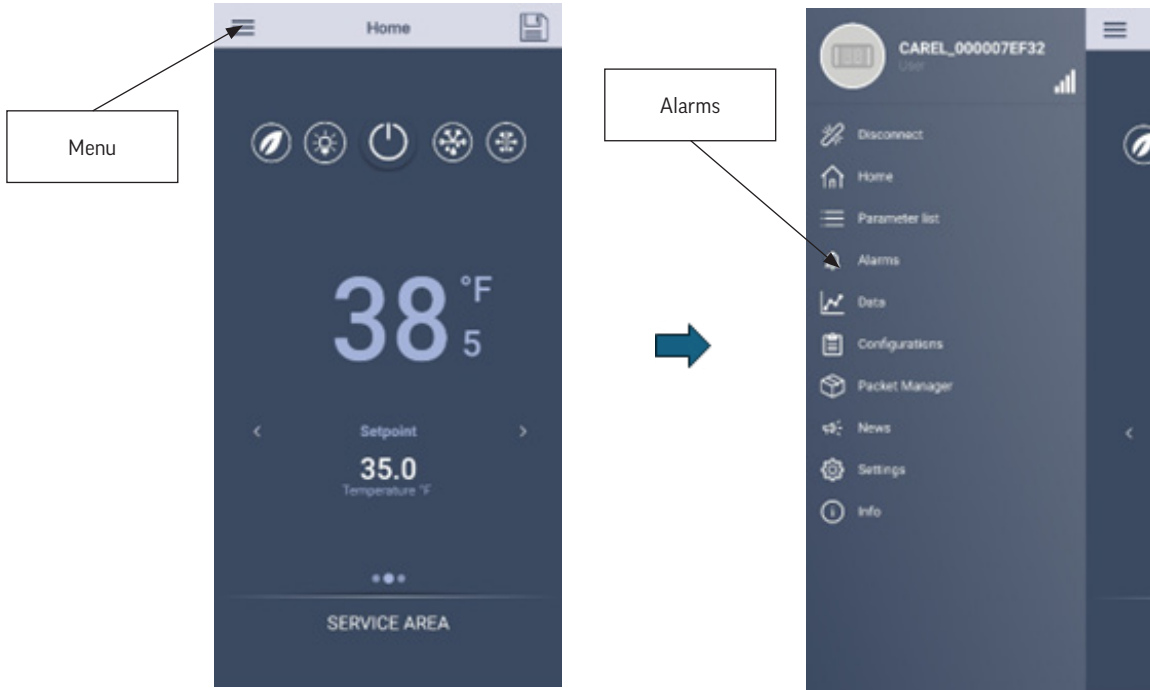

Here you can view active alarm codes and a history of alarms that have gone off.



ALARM CODES

Display Code	Log Code	Description	Icon Display	Alarm Relay	Buzzer	Reset	Effects on Control
Afr	29	Frost protection	YES	YES	YES	Automatic	Compressor OFF
AtS	30	Restart in pump down	NO	NO	NO	Automatic	
CE	28	Configuration write error	NO	NO	NO	Automatic	
cht	17	High condensing temperature warning	NO	NO	NO	Automatic	
CHt	18	High condensing temperature alarm	NO	NO	NO	Manual	Compressor OFF
COM	34	VCC communication error	YES	YES	YES	Automatic	
dA	14	Delayed alarm from external contact	YES	YES	YES	Automatic	Compressor operation in duty setting mode (par A6); dead band, lights and auxiliary output OFF
dor	15	Door open	YES	YES	YES	Automatic	See "Door management"
E1	1	Probe 1 faulty or disconnected	NO	NO	NO	Automatic	According to the associated function (see below)
E2	2	Probe 2 faulty or disconnected	NO	NO	NO	Automatic	
E3	3	Probe 3 faulty or disconnected	NO	NO	NO	Automatic	
E4	4	Probe 4 faulty or disconnected	NO	NO	NO	Automatic	
E5	5	Probe 5 faulty or disconnected	NO	NO	NO	Automatic	
E6	6	Probe S1H faulty or disconnected	NO	NO	NO	Automatic	
E7	7	Probe S2H faulty or disconnected	NO	NO	NO	Automatic	
Ed1	10	Defrost terminated after maximum time	NO	NO	NO	Automatic	
Ed2	11	Defrost on second evaporator terminated after maximum time	NO	NO	NO	Automatic	
EHI	36	High power supply voltage alarm	YES	YES	YES	Automatic	
ELO	37	Low power supply voltage alarm	YES	YES	YES	Automatic	
Etc	9	Clock Error	NO	NO	NO	Manual	Time bands disabled

ALARM CODES CONT'D

Display Code	Log Code	Description	Icon Display	Alarm Relay	Buzzer	Reset	Effects on Control
GHI	19	Generic alarm high threshold	YES	YES	YES	Automatic	
GLO	20	Generic alarm low threshold	YES	YES	YES	Automatic	
HA	21	Type HA HACCP alarm (high temp. during operation)	NO	NO	NO	Manual	
HF	22	Type HF HACCP alarm (high temp. after blackout)	NO	NO	NO	Manual	
HI	24	High temperature	YES	YES	YES	Automatic	
IA	13	Immediate alarm from external contact	YES	YES	YES	Automatic	Compressor operation in duty setting mode (par A6); dead band OFF
LO	23	Low temperature	YES	YES	YES	Automatic	
LP	32	Low pressure	YES	YES	YES	Semi-automatic	Compressor OFF
MAn	38	Output status overridden in manual mode	YES	YES	YES	Automatic	
Pd	26	Maximum pump down time	YES	YES	YES	Automatic	
rE	12	Control probe faulty or disconnected	YES	YES	YES	Automatic	Compressor operation in duty setting mode (par c4); dead band OFF
rSF	31	Refrigerant leak alarm	YES	YES	YES	Manual	Switch off all actuators
SF	27	Configuration not completed correctly	NO	NO	NO	Manual	
SrC	35	Maintenance request	YES	YES	YES	Manual	
UCF	33	VCC operation error	YES	YES	YES	Automatic	

CLEANING AND MAINTENANCE

Cleaning Schedule:

Cabinet	Condenser coil	Gaskets	Routine maintenance
Daily wipe down	Quarterly cleaning	Daily inspection, check that hinges are tight to the cabinet.	Annually
Weekly interior		Every two years.	

Daily Exterior Cleaning

It is much easier to clean on a regular basis than to have to remove stains once they have built up.

1. Wash with a clean sponge and a mild detergent that does not contain chlorine.
2. Rinse with clean water.
3. Dry with a soft cloth.
4. Polish with a soft cloth, wiping with the grain.
5. Wipe weekly with stainless steel cleaner.

Weekly Interior Cleaning

1. Remove all food, food related items and shelves. Store the food at a safe temperature.
2. Disconnect power to the unit (unplug it or switch the breaker off).
3. Remove all loose food particles from the inside walls, floor, door liner and ceiling.
4. Scrub all interior surfaces and door gaskets with a warm (100°F to 110°F) detergent solution and a soft scrub brush.
5. Rinse with clean water and allow to air dry.
6. Return the shelves to the unit and secure them.
7. Restore power.
8. Return food to the unit when it has reached a safe temperature.

CONDENSER CLEANING

Keeping the condenser coil clean is critical to efficient operation.

1. Unplug unit from power supply.



CAUTION

Rotating fan blade can cause personal injury.

Unplug unit from power supply before beginning to clean condenser

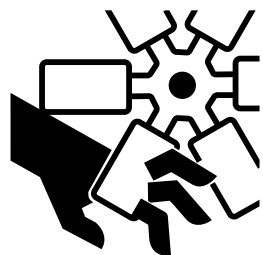

2. Pull out on the bottom of the top panel to disengage the locking clips
3. Raise the hinged panel

4. Remove the panel stand from its clip and secure into the notch in the front right corner of the raised panel
5. Examine condenser surface, if dusty, brush and vacuum the dust and lint from the surface of the coil. Brush up and down to avoid damaging the fins. Use care to not disturb the wires connected to the controller.

Note: If the coil is greasy, the coil will need to be cleaned with coil cleaner and that should be left to an experienced technician.

6. To close, replace stand in its rest and lower panel to the close position. Push firmly on the bottom to engage locking clips

Note: Air filters are not recommended as they restrict the flow of cooling air.



Condenser Surface

METHODS FOR CLEANING STAINLESS STEEL

Cleaning Needed	Cleaning Agent	Method of Application	Affect on Finish
Smears and fingerprints	Areal 20, Lac-O-Nu, Lumin Wash O'Cedar Cream Polish, Stainless Shine.	Rub with cloth as directed on the package.	Satisfactory for use on all finishes. Provides barrier film to minimize prints.
Stubborn Spots and Stains, Baked-On Splatter, and Other Light Discolorations	Allchem Concentrated Cleaner.	Apply with damp sponge or cloth. Rub with damp cloth.	Use in direction of polish lines on No. 4 (polished) finish. May scratch No. 2 (mill) and Nos. 7 and 8 (polished) finishes.
	Samae, Twinkle or Cameo Copper Cleaner	Rub with damp cloth.	
	Grade FFF Italian pumice, whiting, or talc.	Rub with dry cloth.	
	Liquid NuSteel Paste NuSteel or DuBois Temp. Copper's Stainless Steel Cleaner Revere Stainless Cleaner Household cleansers, such as Old Dutch, Lighthouse, Sunbrite, Wyandotte, Bab-O, Gold Dust, Sapolio, Bon Ami, Ajax, or Comet Grade F Italian Pumice, Steel Bright, Lumin Cleaner, Zud, Restore, Sta-Clean, or Highlite. Penny-Brite or Copper-Brite.	Use small amount of cleaner. Rub with dry cloth using a small amount of cleaner. Apply with damp sponge or cloth. Rub with a damp cloth. May contain chlorine bleaches. Rinse thoroughly after use. Rub with a damp cloth. Rub with a dry cloth using a small amount of cleaner.	
Heat tint or discoloration	Penny-Brite or Copper-Brite. Past NuSteel, DuBois Temp, or Tarnite. Revere Stainless Steel Cleaner. Allen Polish, Steel Bright, Tenacious Deposits, Rusty Discolorations, Industrial Atmospheric Stains Wyandotte, Bab-O or Zud.	Rub with a dry cloth. Rub with a dry cloth or stainless steel wool. Apply with damp sponge or cloth. Rub with a damp cloth.	
Burnt-On Foods and Grease Fatty Acids, Milkstone (where swabbing or rubbing is not practical)	Easy-Off, De-Grease-It, 4 to 6% hot solution of such agents as trisodium phosphate or sodium tripolyphosphate or 5 to 15% caustic soda solution	Apply generous coating. Allow to stand for 10-15 minutes. Rinse. Repeated application may be necessary.	Excellent removal, satisfactory for use on all finishes.
Tenacious Deposits, Rusty Discolorations, Industrial Atmospheric Stains	Oakite No. 33, Dilac Texo 12, Texo NY, Flash-Klenz, Caddy Cleaner, Turco Scale 4368 or Permag 57.	Swab and soak with clean cloth. Let stand 15 minutes or more according to directions on package, then rinse and dry.	Satisfactory for use on all finishes
Hard Water Spots and Scale	Vinegar. 5% oxalic acid, 5% sulfamic acid, 5 to 10% phosphoric acid, or Dilac, Oakite No. 33, Texo 12, Texo N.Y.	Swab or wipe with cloth. Rinse with water and dry. Swab or soak with cloth. Let stand 10-15 minutes. Always follow with neutralizer rinse, and dry.	Satisfactory for all finishes. Satisfactory for all finishes. Effective on tenacious deposits or where scale has built up.

HELP

Trouble Diagnosis for the User		
Malfunction	Possible Cause	Likely Solution
No cooling - unit is silent	Unit not plugged in. Fuse or circuit breaker tripped. Power cord plug loose in outlet.	Connect to proper voltage circuit Replace fuse or reset breaker. Check outlet for loose connection, replace as needed
Unit cools but seems to be on all the time	Dirty condenser	Clean condenser
Space temperature too high	Dirty condenser Evaporator iced over Unit in high temperature environment	Clean condenser Defrost evaporator Reduce temperature of room
Space temperature too low	Temperature control	Adjust or replace control
Trouble Diagnosis for the Technician		
No cooling - compressor does not hum	Temp control stuck in open position	Replace temp control.
No cooling - compressor hums but does not start	Low voltage to unit. Compressor starting system failure	Check voltage, correct as needed. Check start relay and start capacitor. See next step.
No cooling - compressor starts but shuts off	Compressor start relay failure Compressor start capacitor failure	Replace relay. Replace capacitor.
No cooling - compressor cycles on and off	Overheating weak overload	Clean condenser, check fan motor and blade. Check refrigerant charge. Replace overload.
Unit cools, but is slow to pull cabinet temperature down	Evaporator fan not turning	Check fan(s), on multiple fan units one fan may be turning slowly and will need to be replaced.
Unit cools but turns on and off frequently	No product in cabinet. Temperature control defective Refrigeration issue	Fill cabinet Replace control Have system checked
Makes excessive noise	Tubing rattle Loose parts Bent or broken fan blade Noisy fan motor	Check tubing for routing Check for loose components Replace fan blade Replace fan motor

FOR THE SERVICE TECH - R290

Refrigeration service should only be attempted by a trained trade professional certified to work on R290 systems.

Here are some critical service items.

This list does not qualify anyone to service the unit. It is a reminder and checklist for the service tech. Keep these in mind for **R290 service**:

- Wire nuts are **NOT** to be used when changing an electrical part.
- The switches in this product are sealed, **only exact replacements** may be used.
- The process tubes are to be used for service access.
- Cut out (with tubing cutter) refrigeration components that are to be replaced. Do **NOT** un-braze.
- Because R290 can be vented into the air during service, the venting **MUST** be in an area free from flame or spark. It must be near an opened window or door.
- A sign noting service of a system containing propane must be attached to the unit during refrigeration service.
- A combustible gas leak detector must be used to inform anyone in the area when propane is present in the air.

Other Information:

Evacuation: It is critical that a refrigeration system be leak free and internally dry. A thorough evacuation with a good vacuum pump with a micron gauge attached is the only way to ensure that the system is dry and ready for a charge of refrigerant.

Charging: The system is critically charged and the proper type and amount **MUST** be weighed in.

Overcharge symptoms: Unit will cool properly but the suction line temperature will be unusually cold. Compressor run time will be longer than normal.

Undercharge symptoms: Long run time, poor cooling and a hot compressor dome are the main symptoms of an undercharge.

FOR THE SERVICE TECH - WIRING DIAGRAM

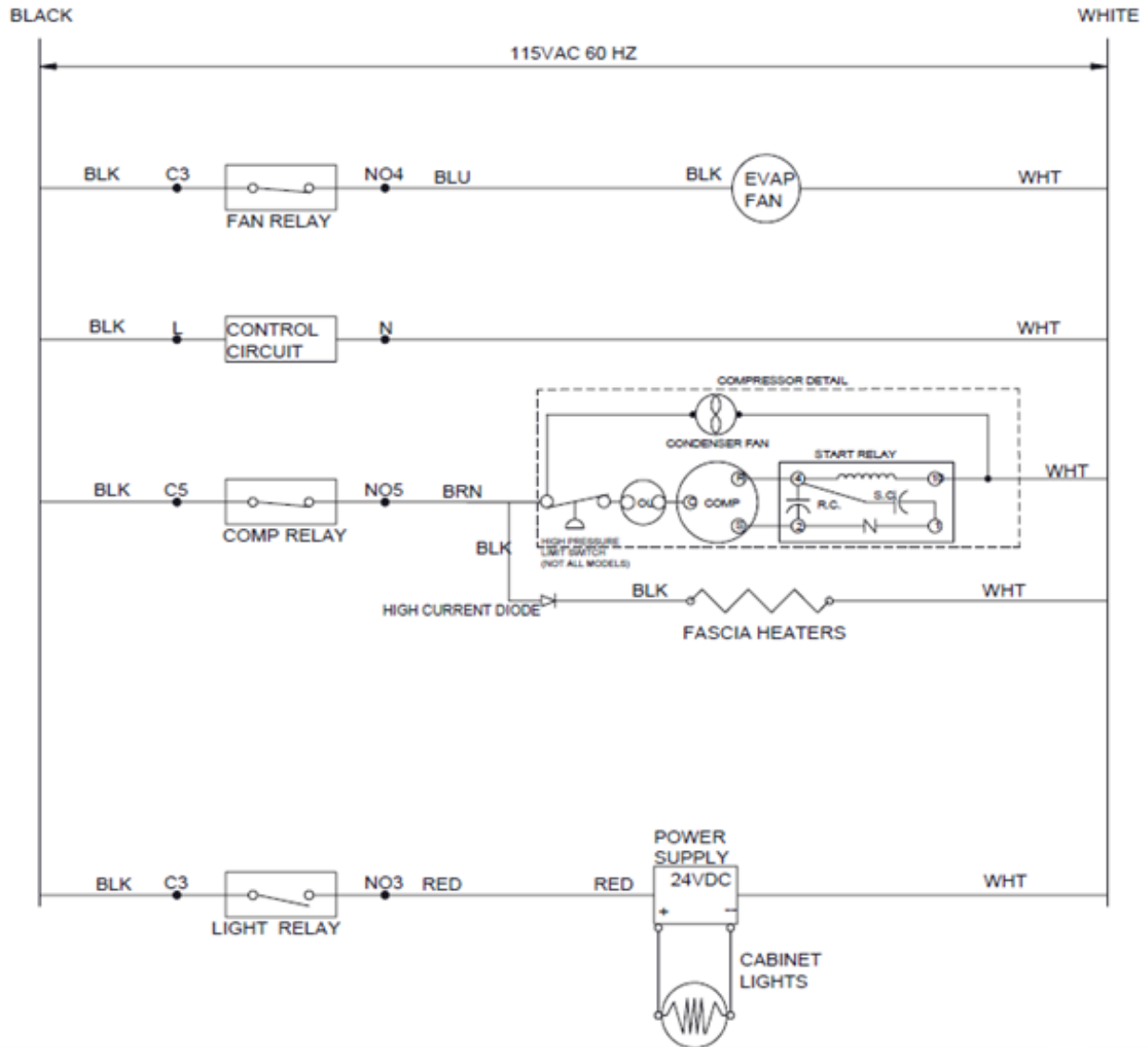

Variable Speed Compressor Wiring Diagram (not all models)

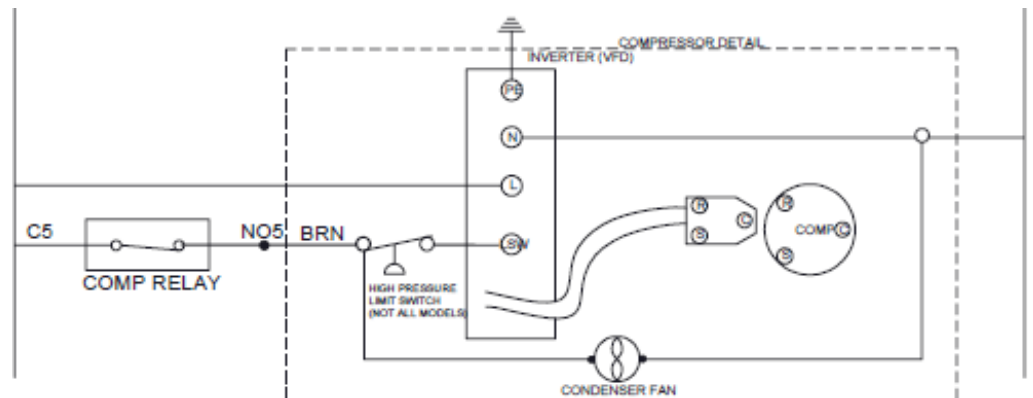

LIMITED WARRANTY

Warranty (Continental USA & Canada Only)

SEVEN (7) YEAR PARTS, LABOR, AND COMPRESSOR LIMITED WARRANTY

Victory® Refrigeration (Victory) warrants to the original purchaser of Victory branded equipment, that such equipment is free from defects in material and workmanship, under normal use, proper maintenance and service as indicated by Victory's installation and operation instructions, for a period of SEVEN (7) years from the date of installation, or eighty-seven (87) months from the date of shipment from the manufacturer, whichever is earlier. In addition, Victory® Refrigeration (Victory) warrants the hermetically/semi-hermetically sealed compressor (part only) for SEVEN (7) years; not to exceed eighty-seven (87) months from the date of shipment from Victory, provided upon receipt of the compressor, manufacturer examination shows the sealed compressor to be defective. This warranty does not cover freight for the replacement compressor or freight for return of the failed compressor. Also, this compressor-part only warranty does NOT apply to any electrical controls, condenser, evaporator, fan motors, overload switch, starting relay, capacitors, temperature control, filter/drier, accumulator, refrigeration tubing, wiring harness, labor charges, or supplies which are covered by the standard warranty above.

*Units shipped after 07/1/2024. Previous warranty applies to units shipped prior.

Exceptions:

- Warranty does not apply for units installed in a Residential application. Units are intended for Commercial use only.
- Blast Chillers carry a 3 year parts and labor warranty; 2 additional years for the compressor.

Normal wear type parts, such as light bulbs/lamps, gaskets, fuses, batteries, blast chiller/freeze probes, thermostat or electronic controller calibration and/or adjustment, and any normal maintenance items as outlined in the Owner's Manual, adjustment of door mechanisms or freight damage are not covered by this warranty. For this warranty, the original purchaser shall be deemed to mean the individual or company for whom the product was originally installed.

Proof of purchase must be supplied to Victory to validate the warranty. This warranty is valid only if equipment is properly installed, and started-up as outlined in the Owner's Manual.

Units that utilize variable speed compressor technology can experience nuisance tripping on Class A GFCI outlets which have a trip limit of 4 mA to 6 mA. To avoid this issue in a location that requires GFCI circuit protection, Beverage Air & Victory recommends using a HUBBELL Model Number GFRST83W 20A Heavy Duty Hospital Grade Self-Test GFCI Receptacle.

Removal or alteration of the serial/ data plate from equipment shall be deemed to release Victory from all warranty obligations or any other obligations, expressed or implied. The warranty does not cover installation, start-up, normal maintenance, food loss, or other consequential damage, and it excludes components that are removable without tools. Our obligation under this warranty shall be limited to repairing or replacing, including labor, any part of such product, which proves defective.

Victory reserves the right to examine any product claimed to be defective. The labor warranty shall be for self-contained units only and for standard straight time, which is defined as normal service rate time, for service performed during normal working hours. Any service requested outside of a servicer's normal working hours will be covered under this warranty at the normal rate and any additional overtime rate will be the responsibility of the equipment purchaser. Victory shall not be responsible for any costs incurred if the work is performed by other than Victory's authorized service personnel. Reimbursement claims for parts and/or labor service costs must be made in writing. Model, cabinet serial number and installation location must be shown on the claim. A receipted bill from the servicing agency must accompany the claim, together with full details of the service problems, diagnosis and work performed. Victory reserves sole discretion whether further documentation on a claim is to be submitted. Any part determined to be defective in the product should be returned to the company within thirty (30) days under the terms of this warranty and must be accompanied by a record of the cabinet model, serial number, with a return material authorization number (RMA#) issued by Victory.

LIMITED WARRANTY (CONTINUED)

Special installation/applications, including remote locations, are limited in coverage by this warranty. Any installation that requires extra work, and/or travel, to gain access to the unit for service is the sole responsibility of the equipment purchaser. Improper operation resulting from factors, including but not limited to, improper or negligent cleaning and maintenance, low voltage conditions, inadequate wiring, outdoor use and accidental damage are not manufacturing defects and are strictly the responsibility of the purchaser.

Except Blast Chillers, a product is designed for maintaining temperature and not bringing food to a desired temperature, so cannot be held responsible for this function under warranty.

Units must be in conditioned environments or warranty will be void.

Condenser coils must be cleaned at regular intervals. Failure to do so can cause compressor malfunction and will void warranty. Although cleaning requirements vary in accordance with the operation of various products, Victory recommends a minimum monthly cleaning.

NOTE: NO CLAIMS CAN BE MADE AGAINST THESE WARRANTIES FOR SPOILAGE OF PRODUCTS, LOSS OF SALES OR CONSEQUENTIAL DAMAGES. THE FOREGOING WARRANTIES ARE EXPRESSLY GIVEN IN LIEU OF ALL OTHER WARRANTIES, EXPRESS, IMPLIED, OR STATUTORY, INCLUDING THE IMPLIED WARRANTIES OF MERCHANTABILITY AND FITNESS FOR A PARTICULAR PURPOSE, WHICH ARE HEREBY DISCLAIMED, AND ALL OTHER OBLIGATIONS OR LIABILITIES ON OUR PART, AND WE NEITHER ASSUME, NOR AUTHORIZE ANY OTHER PERSON TO ASSUME FOR US, ANY OBLIGATION OR LIABILITY IN CONNECTION WITH THE SALE OF SAID REFRIGERATION UNITS OR ANY PARTS THEREOF.

These warranties shall not be assignable and shall be honored only in so far as the original purchaser.

These warranties do not apply outside the limits of the USA and Canada, nor do they apply to any part that has been subject to misuse, neglect, alteration, accident, or to any damage caused by transportation, flood, fire, acts of terrorism, or acts of God.

LIMITATION OF LIABILITY:

Victory or its affiliates shall not be liable for any indirect, incidental, special or consequential damages, or losses of a commercial nature arising out of malfunctioning equipment or its parts or components thereof, because of defects in material or workmanship. In no event shall Victory be liable for a sum more than the purchase price of the item.

THE ORIGINAL OWNER'S SOLE AND EXCLUSIVE REMEDY AND VICTORY'S SOLE AND EXCLUSIVE LIABILITY SHALL BE LIMITED TO THE REPAIR OR REPLACEMENT OF PARTS OR COMPONENTS CONTAINED IN THE EQUIPMENT IDENTIFIED ABOVE WHICH UNDER NORMAL USE AND SERVICE MALFUNCTION AS A RESULT OF DEFECTS IN MATERIAL OR WORKMANSHIP, SUBJECT TO THE APPLICABLE PROVISIONS AND LIMITATIONS STATED ABOVE.

07/2024

Warranty Registration

Register your product online at Victory.com/parts-service or fill out and mail the form below.

Cabinet Model Number: _____ Date Of Installation: _____

Cabinet Serial Number: _____

Location Of Product

Business Name: _____

Business Street: _____

Business City: _____ State: _____ Postal Code: _____

Mail to: Victory, 3779 Champion Blvd, Winston-Salem, NC 27105

Rev. 04/25

