

VULCAN

INSTALLATION, OPERATION, SERVICE & PARTS MANUAL

FOOD STEAMERS

MODEL

VSX24G	ML-52163
VSX36G	ML-52360
VSX42GT	ML-52832
VSX24E	ML-52164
VSX36E	ML-52829
VSX42ET	ML-52833
VSX24D	ML-52827
VSX36D	ML-52830
VSX42DT	ML-52834
VSX36R	ML-52831
VSX42RT	ML-52835



MODEL VSX24

IMPORTANT FOR YOUR SAFETY

THIS MANUAL HAS BEEN PREPARED FOR PERSONNEL QUALIFIED TO INSTALL GAS EQUIPMENT, WHO SHOULD PERFORM THE INITIAL FIELD START-UP AND ADJUSTMENTS OF THE EQUIPMENT COVERED BY THIS MANUAL.

POST IN A PROMINENT LOCATION THE INSTRUCTIONS TO BE FOLLOWED IN THE EVENT THE SMELL OF GAS IS DETECTED. THIS INFORMATION CAN BE OBTAINED FROM THE LOCAL GAS SUPPLIER.

IMPORTANT

IN THE EVENT A GAS ODOR IS DETECTED, SHUT DOWN UNITS AT MAIN SHUTOFF VALVE AND CONTACT THE LOCAL GAS COMPANY OR GAS SUPPLIER FOR SERVICE.

FOR YOUR SAFETY

DO NOT STORE OR USE GASOLINE OR OTHER FLAMMABLE VAPORS OR LIQUIDS IN THE VICINITY OF THIS OR ANY OTHER APPLIANCE.

WARNING

IMPROPER INSTALLATION, ADJUSTMENT, ALTERATION, SERVICE OR MAINTENANCE CAN CAUSE PROPERTY DAMAGE, INJURY OR DEATH. READ THE INSTALLATION, OPERATING AND MAINTENANCE INSTRUCTIONS THOROUGHLY BEFORE INSTALLING OR SERVICING THIS EQUIPMENT.

IN THE EVENT OF A POWER FAILURE, DO NOT ATTEMPT TO OPERATE THIS DEVICE.

INSTALLATION, OPERATION, SERVICE & PARTS MANUAL CONVECTION FOOD STEAMERS GAS, ELECTRIC, REGENERATIVE OR DIRECT STEAM MODELS VSX24, VSX36 & VSX42

INDEX

PLEASE KEEP THIS MANUAL FOR FUTURE REFERENCE

Your Vulcan Steam Cooker is produced with quality workmanship and material. Proper installation, usage and maintenance of your steam cooker will result in many years of satisfactory performance.

The manufacturer suggests that you thoroughly read this entire manual and carefully follow all of the instructions provided.

DESCRIPTION	PAGE
INDEX	4, 5
INSTALLATION	6
UNPACKING	6
LOCATION	6
INSTALLATION CODES AND STANDARDS	6, 7
LEVELING AND ANCHORING	7
SERVICE CONNECTIONS	7-19
Steam Connections	7
Gas Connections	7
Electrical Connections	8
Drain Connections	8
Plumbing Connections	8
VENT HOOD	8
SERVICE CONNECTION DIAGRAMS	9-19
START-UP TEST RUN	20, 21
BLOW DOWN BOILER	21
OPERATION	22
CONTROLS - CABINET BASE GENERATOR	22, 23
CONTROLS - COMPARTMENT	24
LIGHTING STANDING PILOT (GAS BASE GENERATORS ONLY)	24

DESCRIPTION	PAGE
OPERATION (CONT'D.)	
OPERATING STEAMERS WITH INTERMITTENT PILOTS (GAS BASE GENERATORS ONLY)	24, 25
DAILY STARTING PROCEDURE	25
CLEANING	25, 26
MAINTENANCE	26
COOKING CHART	27-29
TROUBLESHOOTING	30-32
SERVICE	33
COOKING COMPARTMENT	33
CABINET BASE GENERATOR	33-38
All Generators	33-37
Gas Generators	37, 38
Electric Generators	38
Regenerating (Steam Coil) Generators	38
REPLACEMENT PARTS LIST	39-70

INSTALLATION

UNPACKING

This steam cooker was inspected before leaving the factory. The transportation company assumes full responsibility for safe delivery upon acceptance of the shipment. Immediately after unpacking, check for possible shipping damage. If the cooker is found to be damaged after unpacking, save the packaging material and contact the carrier within 15 days of delivery.

Before installing, verify that the gas (natural or propane) and/or electrical supplies agree with the specifications on the rating plate which is located on the inside base cabinet door. If the supply and equipment requirements do not agree, do not proceed with the installation. Contact your dealer or Vulcan-Hart immediately.

LOCATION

Position the steamer in its final location. Check that there are sufficient clearances to service the controls, for door swings, etc., so there will be no problem in making the required supply and drain connections. Recommended clearances are 18" on the sides and back and 36" in the front.

Allow enough space between any other piece of equipment or a wall for access. All service on the compartment controls begins by removing the panel on the right side of the compartments. Service on the cabinet base may require the removal of the panel on either or both the left or right sides.

A floor drain (open gap) is required immediately below the steamer drain.

An exhaust system should be located directly above the steamer to exhaust steam and heat generated by the steamer.

For Gas Powered Steam Generators Only

The equipment area must be kept free and clear of combustible substances.

The steamer, when installed, must have a minimum clearance from combustible and noncombustible construction of 6" at the sides and 6" at the back. It must be installed on a noncombustible floor. The installation location must allow adequate clearances for servicing and proper operation.

The steamer must be installed so that the flow of combustion and ventilation air will not be obstructed. Adequate clearance for air openings into the combustion chamber of the gas cabinet base generator must be provided. The floor area beneath the burners must be kept free and clear. Make sure there is an adequate supply of air in the room to allow for combustion of the gas at the burners.

When steamers are mounted on casters, you must use a connector that complies with the Standard for Connectors of Movable Gas Appliances, ANSI-Z21.69 (latest edition), and a quick-disconnect device that complies with the Standard for Quick-Disconnect Devices for Use With Gas Fuel, ANSI-Z21.41 (latest edition).

Provide a gas line strain relief to limit movement of the steamer without depending on the connector and/or any quick-disconnect device or its associated piping to limit movement of the steamer. Attach the gas line strain relief to the rear of the steamer (Fig. 1).

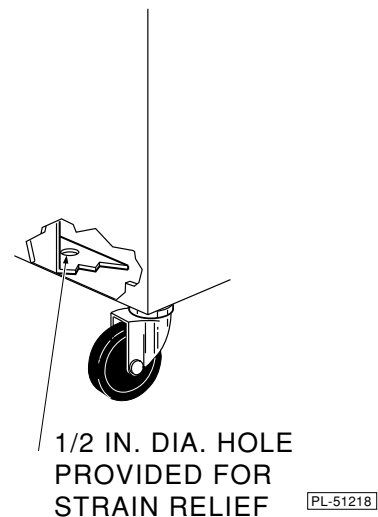

Should it be necessary to disconnect the restraint, turn off the gas supply before disconnection. Reconnect the restraint before turning the gas supply on and returning the steamer to its installation position.

INSTALLATION CODES AND STANDARDS

Your Vulcan steamer must be installed in accordance with:

In the United States:

1. State and local codes.
2. National Fuel Gas Code, ANSI-Z233.1 (latest edition). Copies may be obtained from The American Gas Assoc., Inc., 1515 Wilson Blvd., Arlington, VA 22209.
3. National Electrical Code, ANSI/NFPA No. 70 (latest edition). Copies may be obtained from The National Fire Protection Assoc., Batterymarch Park, Quincy, MA 02269.

In Canada:

1. Local codes.
2. CAN/CGA-B149.1 Installation for Natural Gas Burning Appliances and Equipment (latest edition).
3. CAN/CGA-B149.2 Installation for Propane Burning Appliances and Equipment (latest edition). Copies may be obtained from The Canadian Gas Assoc., 55 Scarsdale Road, Don Mills, Ontario, Canada M3B 2R3.
4. The Canadian Electrical Code, Part 1, C22.1 (latest edition). Copies may be obtained from the Canadian Standards Assoc., 178 Rexdale Blvd., Rexdale, Ontario, Canada M9W 1R3.

LEVELING AND ANCHORING

Using a spirit level, adjust the feet to level the steamer left-to-right and front-to-back. Steamers should be elevated in the front just enough (about 1/16" to 1/8") to give proper drainage. To do this, rotate rear leg adjusting nut by 1 to 1½ turns clockwise after leveling. (Check by pouring a little water in the compartment; all the water should drain.)

The rear feet have holes in the flanges for anchor bolts. **DIRECT STEAM COOKERS (STEAMERS WITHOUT GENERATORS) MUST BE ANCHORED TO THE FLOOR.**

SERVICE CONNECTIONS (See Fig's. 2-12)

STEAM CONNECTIONS

Provide dry steam to the inlets. If the steam is heavy with condensate, install a ball float trap before the pressure regulator valve. To ensure rapid heat-up of heavy cold loads, the steam supply line must be sized to maintain pressure and flow as follows:

Direct Connected Steamers (Fig's. 2-4)

Supply steam at a pressure of 10-12 psi and at a minimum flow rate of 50 lb. per hour per compartment. A pressure reducing valve is furnished and set at 10 psig. Additional steam kettles and kettle modules can be interconnected to the steamer. Consult Vulcan-Hart for recommendations.

Regenerating (Steam Coil) Generators (Fig's. 5 & 6)

The steam supply to the steam coils must be 15 psi at a minimum flow rate of 125 lb. per hour to the coil.

GAS CONNECTIONS (Fig's. 7, 8 & 9)

All gas supply connections and any pipe joint compound used must be resistant to the action of propane gases.

Connect gas supply to the gas cabinet base generator using ¾" pipe. Make sure the pipes are clean and free of obstructions.

Codes require that a gas shutoff valve be installed in the gas line ahead of the steam generator.

This gas cabinet base generator is equipped with fixed orifices for use with natural or propane gas and no adjustment is necessary.

The gas line must be capable of delivering gas to the generator without excessive pressure drop at the rate specified on the rating plate. The generator is equipped with a factory preset pressure regulator. Natural gas pressure regulators are preset for 3.5" W.C. (Water Column) for natural gas. Propane gas pressure regulators are preset for 10" W.C. No further adjustment should be required.

WARNING: PRIOR TO LIGHTING, CHECK ALL JOINTS IN THE GAS SUPPLY LINE FOR LEAKS. USE SOAP AND WATER SOLUTION. DO NOT USE AN OPEN FLAME.

After piping has been checked for leaks, all piping receiving gas should be fully purged to remove air.

Testing The Gas Supply System

When test pressures exceed ½ psig (3.45 kPa), the generator and its individual shutoff valve must be disconnected from the gas supply piping system.

When test pressures are ½ psig (3.45 kPa) or less, the generator must be isolated from the gas supply system by closing its individual manual shutoff valve.

ELECTRICAL CONNECTIONS (Fig's. 2-12)

WARNING: ELECTRICAL AND GROUNDING CONNECTIONS MUST COMPLY WITH THE APPLICABLE PORTIONS OF THE NATIONAL ELECTRICAL CODE ANSI/NFPA-70 (LATEST EDITION) AND/OR OTHER LOCAL ELECTRICAL CODES.

WARNING: DISCONNECT ELECTRICAL POWER SUPPLY AND PLACE A TAG AT THE DISCONNECT SWITCH TO INDICATE THAT YOU ARE WORKING ON THE CIRCUIT.

Do not connect the steamer to electrical supply until after gas connections (if applicable) have been made.

All Models

Unless otherwise specified, field wire electrical connection is to be 120 volts, 60 Hertz, single phase, with grounding wire. Connect electrical supply to the pigtail leads in the supply junction box located next to the boiler control box for electric generators in a 24" wide base, and under the boiler control box for all other generator bases. The supply junction box is located on the underside of the cabinet top on direct steam models. Use copper wire suitable for at least 75°C temperature. A grounding wire must be connected to the ground lug in the junction box.

When optional step down transformer is used on electrically heated generators, the 120 volt connection is not required.

Electrically Heated Generators

Make the electrical supply connection in the junction box on the contactor box. The supply wiring and circuit protection must be adequate for the kilowatt load drawn by the cooker. A grounding wire must be connected to the ground lug in the junction box. Use copper wire of the size and temperature rating marked on the supply label.

DRAIN CONNECTIONS (Fig's. 2-12)

Drain connections must be the open air gap type. Provide a suitable drain under the drain pipes. For proper drainage, a floor sink with minimum of 12" depth is recommended.

CAUTION: In order to avoid any back pressure in the steamer, do not connect solidly to any drain connection.

PLUMBING CONNECTIONS (Fig's. 2-12)

WARNING: PLUMBING CONNECTIONS MUST COMPLY WITH APPLICABLE SANITARY, SAFETY AND PLUMBING CODES.

Before connecting the steamer to water, the water supply should be analyzed to make sure hardness is less than 2.0 grains per gallon and pH of 7.5. The water supply should be clear with no sediment or suspended material present. If the water supply fails to meet these standards, it will be necessary to install a water conditioner on the boiler water feed. **APPLIANCE FAILURE CAUSED BY INADEQUATE WATER QUALITY IS NOT COVERED UNDER WARRANTY.**

The use of strainers or filters will not remove minerals from the water.

Cold Water

Used as boiler fill water and cold water condenser on boiler blowdown line. Connect a cold water line to the ¼" N.P.T. cold water condenser line. Twenty (20) psig minimum water pressure is required at the connections.

VENT HOOD

Information on the construction and installation of ventilating hoods may be obtained from the standard for "Vapor Removal from Cooking Equipment," NFPA No. 96 (latest edition).

SERVICE CONNECTIONS DIRECT STEAM, VSX24D

FIG. 2

LEGEND

- A. COLD SUPPLY WATER CONNECTION: 1/4" TUBING FOR COLD WATER CONDENSER SUPPLY, AND BOILER FEED.
- B. STEAM SUPPLY CONNECTION: 3/4" NPT FOR STEAM COOKING (A STEAM PRESSURE REDUCING VALVE IS MOUNTED AS STANDARD AND SET FOR 10 PSI MAXIMUM INPUT TO UNIT).
- C. ELECTRICAL CONNECTION FOR CONTROLS: 120V/60HZ/1PH/300 WATT MAXIMUM, POWER SUPPLY WITH GROUNDING WIRE REQUIRED. (FOR OTHER THAN 120 VOLT SUPPLY CONSULT FACTORY FOR LOCATION OF THIS CONNECTION.)
- D. DRAIN: COPPERTUBE COMPARTMENT & EXHAUST GROUP APPROXIMATELY 2" IN DIAMETER. (PROVIDE AN OPEN AIR GAP TYPE DRAIN DIRECTLY UNDER THE UNIT FRAME. DO NOT CONNECT SOLIDLY TO ANY DRAIN CONNECTION.)

NOTE: DIMENSIONS WHICH LOCATE THE ABOVE CONNECTIONS HAVE A TOLERANCE OF ± 3 IN. (± 75 MM). NORMAL DIMENSIONS ARE IN INCHES. DIMENSIONS IN () ARE IN MILLIMETERS.

EQUIPMENT CLEARANCES TO COMBUSTIBLE CONSTRUCTION

REAR: 2 IN. MIN. (50 MM.)

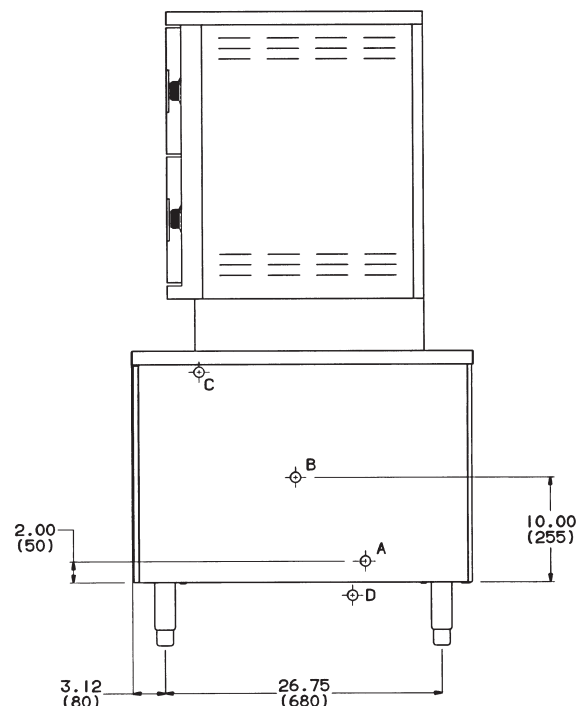
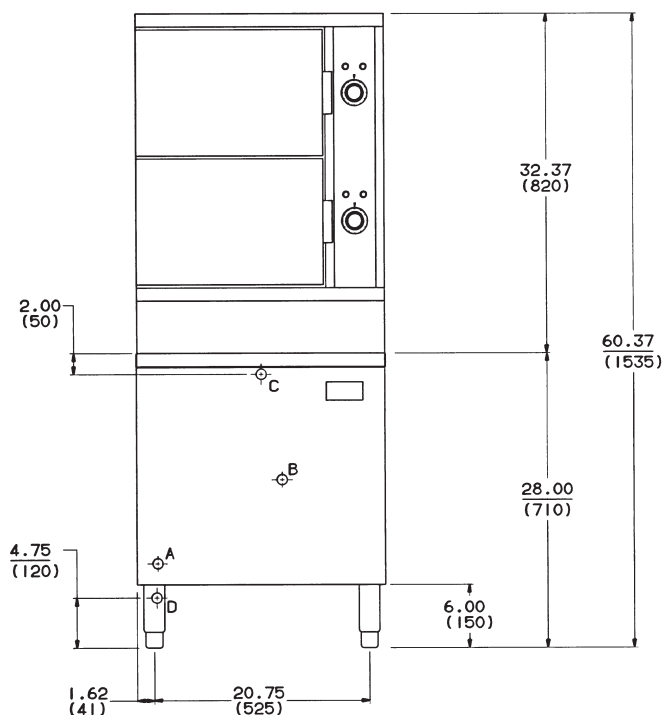
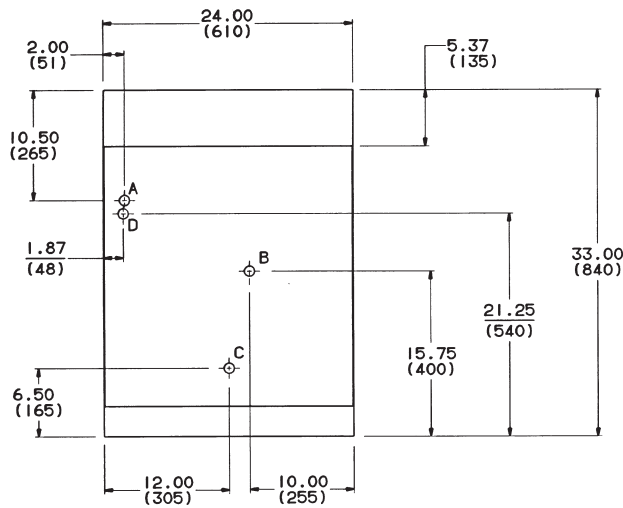

SERVICE CONNECTIONS DIRECT STEAM, VSX36D

FIG. 3

LEGEND

- A. COLD SUPPLY WATER CONNECTION: ¼" TUBING FOR COLD WATER CONDENSER, AND BOILER FEED.
- B. STEAM SUPPLY CONNECTION: ¾" NPT FOR STEAM COOKING. (A STEAM PRESSURE REDUCING VALVE IS MOUNTED AS STANDARD AND SET FOR 10 PSI MAXIMUM INPUT TO UNIT.)
- C. ELECTRICAL CONNECTION FOR CONTROLS: 120V/60HZ/1PH/300 WATT MAXIMUM, POWER SUPPLY WITH GROUNDING WIRE REQUIRED. (FOR OTHER THAN 120 VOLT SUPPLY CONSULT FACTORY FOR LOCATION OF THIS CONNECTION.)
- D. DRAIN: COPPERTUBE COMPARTMENT & EXHAUST GROUP APPROXIMATELY 2" DIAMETER. (PROVIDE AN OPEN AIR GAP TYPE DRAIN DIRECTLY UNDER UNIT FRAME. DO NOT CONNECT SOLIDLY TO ANY DRAIN CONNECTION.)

NOTE: DIMENSIONS WHICH LOCATE THE ABOVE CONNECTIONS HAVE A TOLERANCE OF ± 3 IN. (± 75 MM). NORMAL DIMENSIONS ARE IN INCHES. DIMENSIONS IN () ARE IN MILLIMETERS.

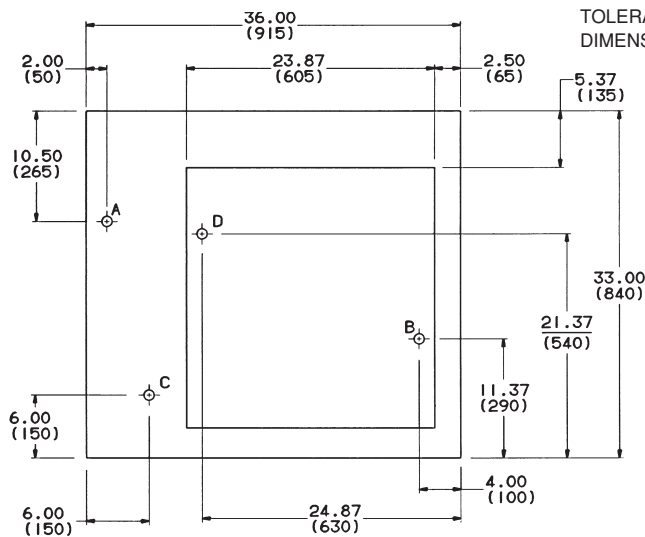

EQUIPMENT CLEARANCES TO COMBUSTIBLE CONSTRUCTION

REAR: 2 IN. MIN. (50 MM.)

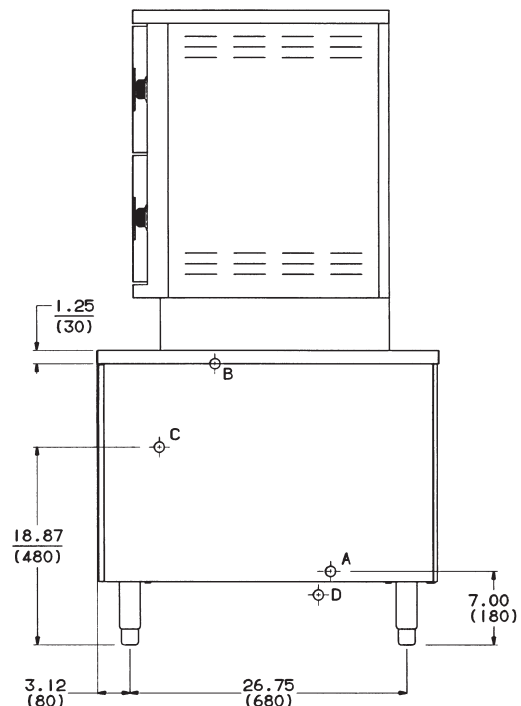
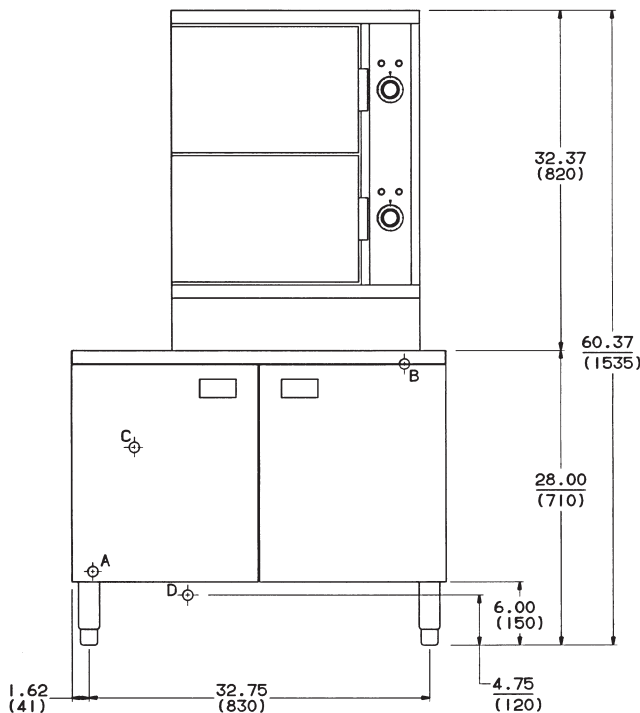

SERVICE CONNECTIONS DIRECT STEAM, VSX42DT

FIG. 4

LEGEND

- A. COLD SUPPLY WATER CONNECTION: 1/4" TUBING FOR COLD WATER CONDENSER, AND BOILER FEED.
- B. STEAM SUPPLY CONNECTION: 3/4" NPT FOR STEAM COOKING. (A STEAM PRESSURE REDUCING VALVE IS MOUNTED AS STANDARD AND SET FOR 10 PSI MAXIMUM INPUT TO UNIT.)
- C. ELECTRICAL CONNECTION FOR CONTROLS: 120V/60HZ/1PH/300 WATT MAXIMUM, POWER SUPPLY WITH GROUNDING WIRE REQUIRED. (FOR OTHER THAN 120 VOLT SUPPLY CONSULT FACTORY FOR LOCATION OF THIS CONNECTION.)
- D. DRAIN: COPPERTUBE COMPARTMENT & EXHAUST GROUP APPROXIMATELY 2" DIAMETER. (PROVIDE AN OPEN AIR GAP TYPE DRAIN DIRECTLY UNDER UNIT FRAME. DO NOT CONNECT SOLIDLY TO ANY DRAIN CONNECTION.)

NOTE: DIMENSIONS WHICH LOCATE THE ABOVE CONNECTIONS HAVE A TOLERANCE OF ± 3 IN. (± 75 MM). NORMAL DIMENSIONS ARE IN INCHES. DIMENSIONS IN () ARE IN MILLIMETERS.

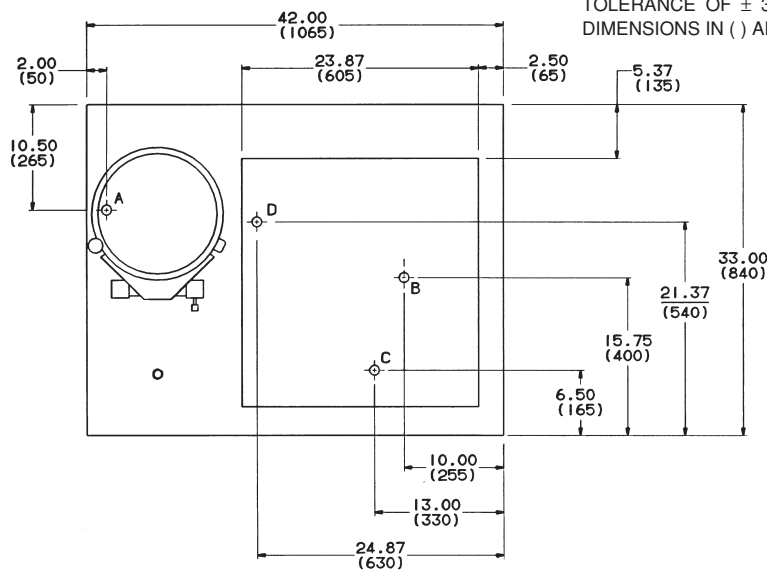

EQUIPMENT CLEARANCES TO COMBUSTIBLE CONSTRUCTION

REAR: 2 IN. MIN. (50 MM.)

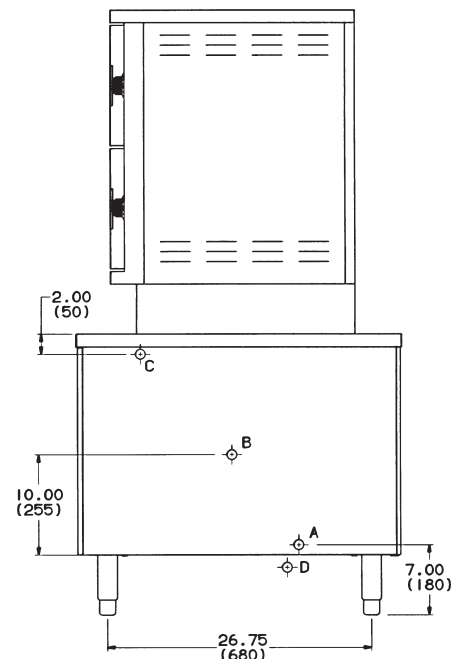
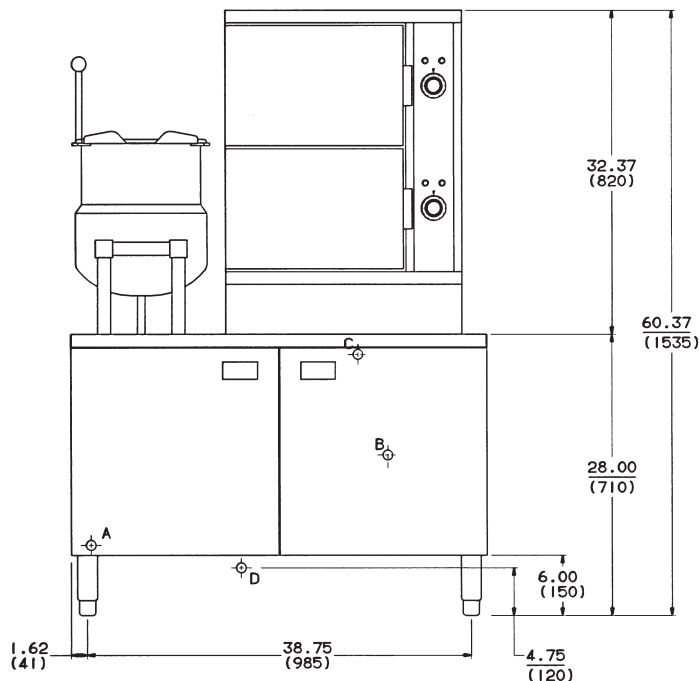

SERVICE CONNECTIONS REGENERATING STEAM, VSX36R

FIG. 5

LEGEND

- A. STEAM SUPPLY CONNECTION: 3/4" NPT FOR STEAM INLET TO BOILER. (A STEAM PRESSURE REDUCING VALVE IS SHIPPED WITH THE UNIT AND MUST BE FIELD INSTALLED AND ADJUSTED FOR 15 PSI MAXIMUM TO THE UNIT.)
- B. ELECTRICAL CONNECTION FOR CONTROLS: 120V/60HZ/1PH/300 WATT MAXIMUM, POWER SUPPLY WITH GROUNDING WIRE REQUIRED. (FOR OTHER THAN 120 VOLT SUPPLY CONSULT FACTORY FOR LOCATION OF THIS CONNECTION.)
- C. DRAIN: COMPARTMENT, BOILER AND EXHAUST GROUP APPROXIMATELY 2" IN DIAMETER. (PROVIDE AN OPEN AIR GAP TYPE DRAIN DIRECTLY UNDER UNIT FRAME. DO NOT CONNECT SOLIDLY TO ANY DRAIN CONNECTION.)
- D. COLD SUPPLY WATER CONNECTION: 1/4" NPT FOR BOILER DRAIN & COMPARTMENT DRAIN COLD WATER CONDENSERS, AND BOILER FEED.

NOTE: DIMENSIONS WHICH LOCATE THE ABOVE CONNECTIONS HAVE A TOLERANCE OF $\pm 3"$ (± 75 MM). NORMAL DIMENSIONS ARE IN INCHES. DIMENSIONS IN () ARE IN MILLIMETERS.

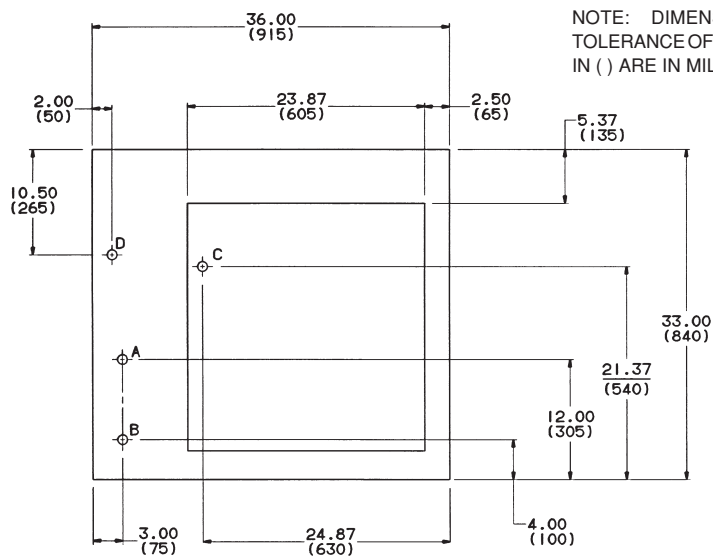

EQUIPMENT CLEARANCES
TO COMBUSTIBLE CONSTRUCTION

REAR: 2 IN. MIN. (50 MM.)

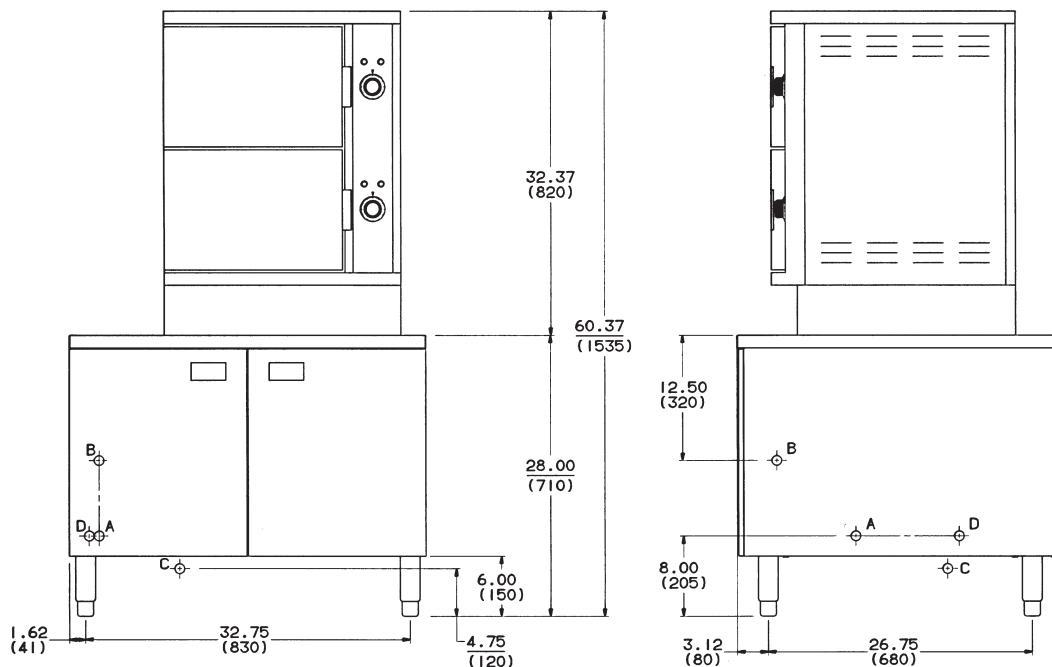

SERVICE CONNECTIONS REGENERATING STEAM, VSX42RT

FIG. 6

LEGEND

- A. STEAM SUPPLY CONNECTION: 3/4" NPT FOR STEAM INLET TO BOILER. (A STEAM PRESSURE REDUCING VALVE IS SHIPPED WITH THE UNIT AND MUST BE FIELD INSTALLED AND ADJUSTED FOR 15 PSI MAXIMUM TO THE UNIT.)
- B. ELECTRICAL CONNECTION FOR CONTROLS: 120V/60HZ/1PH/300 WATT MAXIMUM, POWER SUPPLY WITH GROUNDING WIRE REQUIRED. (FOR OTHER THAN 120 VOLT SUPPLY CONSULT FACTORY FOR LOCATION OF THIS CONNECTION.)
- C. DRAIN: COMPARTMENT, BOILER AND EXHAUST GROUP APPROXIMATELY 2" IN DIAMETER. (PROVIDE AN OPEN AIR GAP TYPE DRAIN DIRECTLY UNDER UNIT FRAME. DO NOT CONNECT SOLIDLY TO ANY DRAIN CONNECTION.)
- D. COLD SUPPLY WATER CONNECTION: 1/4" NPT FOR BOILER DRAIN & COMPARTMENT DRAIN COLD WATER CONDENSERS, AND BOILER FEED.

NOTE: DIMENSIONS WHICH LOCATE THE ABOVE CONNECTIONS HAVE A TOLERANCE OF $\pm 3"$ (± 75 MM). NORMAL DIMENSIONS ARE IN INCHES. DIMENSIONS IN () ARE IN MILLIMETERS.

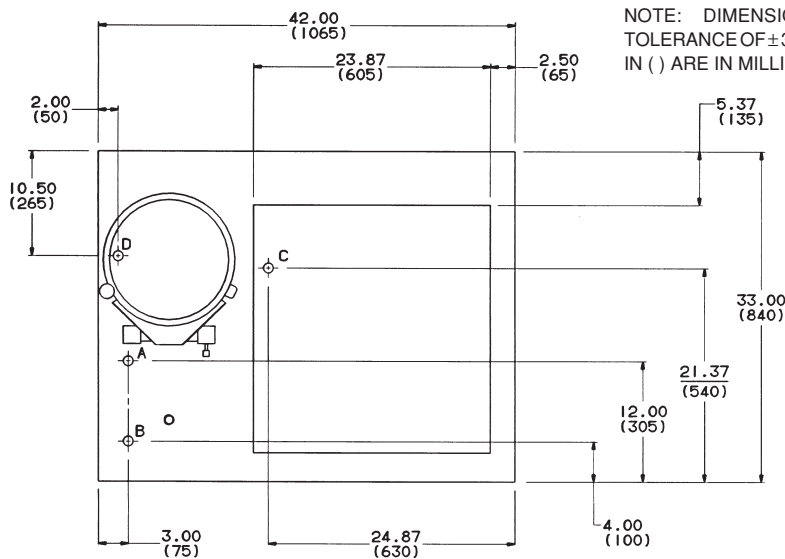

EQUIPMENT CLEARANCES
TO COMBUSTIBLE CONSTRUCTION

REAR: 2 IN. MIN. (50 MM.)

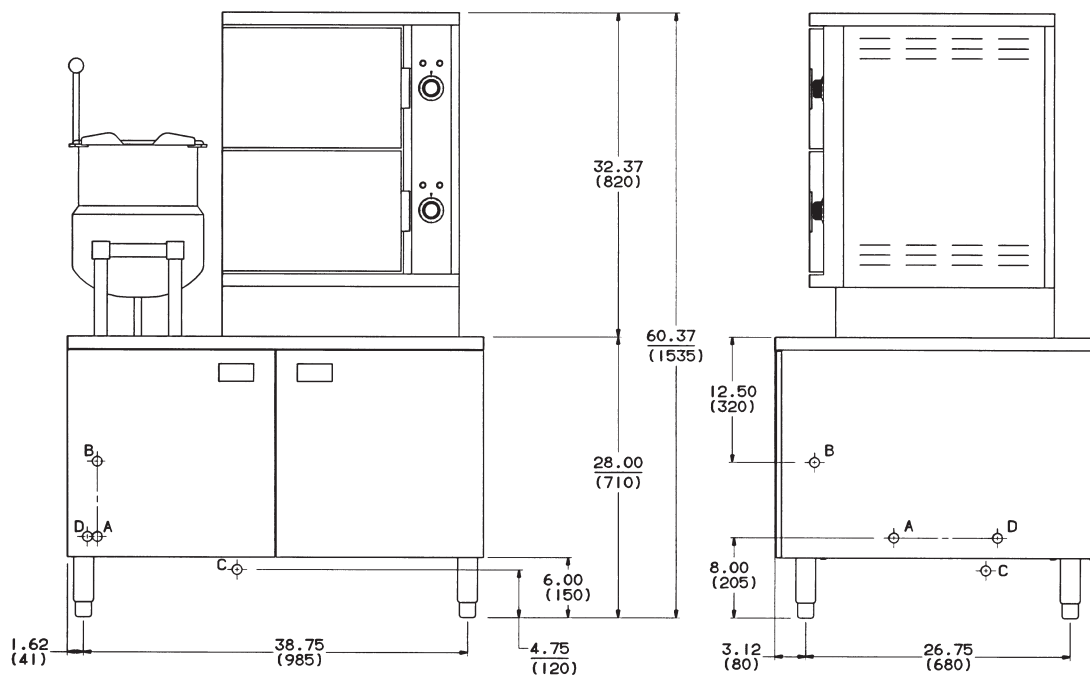

SERVICE CONNECTIONS GAS HEAT, VSX24G

FIG. 7

LEGEND

- A. GAS CONNECTION: 3/4" NPT.
- B. ELECTRICAL CONNECTION FOR CONTROLS: 120V/60HZ/1PH/300 WATT MAXIMUM, POWER SUPPLY WITH GROUNDING WIRE REQUIRED. (FOR OTHER THAN 120 VOLT SUPPLY CONSULT FACTORY FOR LOCATION OF THIS CONNECTION.)
- C. DRAIN: COMPARTMENT, BOILER AND EXHAUST GROUP APPROXIMATELY 3/2" IN DIAMETER. (PROVIDE AN OPEN AIR GAP TYPE DRAIN DIRECTLY UNDER UNIT FRAME. DO NOT CONNECT SOLIDLY TO ANY DRAIN CONNECTION.)
- D. COLD SUPPLY WATER CONNECTION: 1/2" NPT FOR BOILER DRAIN & COMPARTMENT DRAIN COLD WATER CONDENSERS, AND BOILER FEED.

NOTE: DIMENSIONS WHICH LOCATE THE ABOVE CONNECTIONS HAVE A TOLERANCE OF ± 3 IN. (± 75 MM). NORMAL DIMENSIONS ARE IN INCHES. DIMENSIONS IN () ARE IN MILLIMETERS.

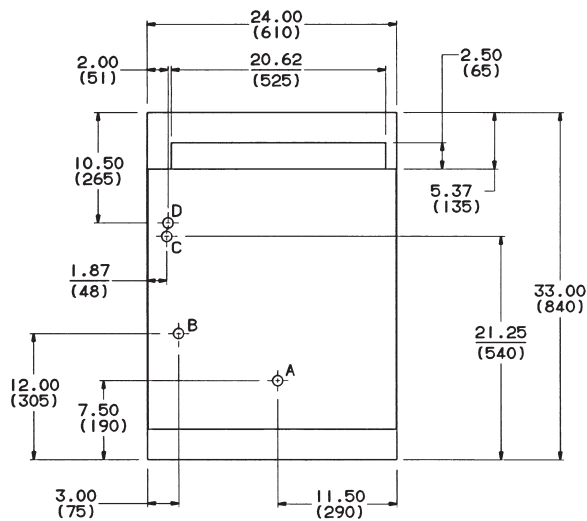

EQUIPMENT CLEARANCES TO COMBUSTIBLE CONSTRUCTION

REAR: 6 IN. MIN. (150 MM.)
LEFT SIDE: 6 IN. MIN. (150 MM.)
RIGHT SIDE: 6 IN. MIN. (150 MM.)

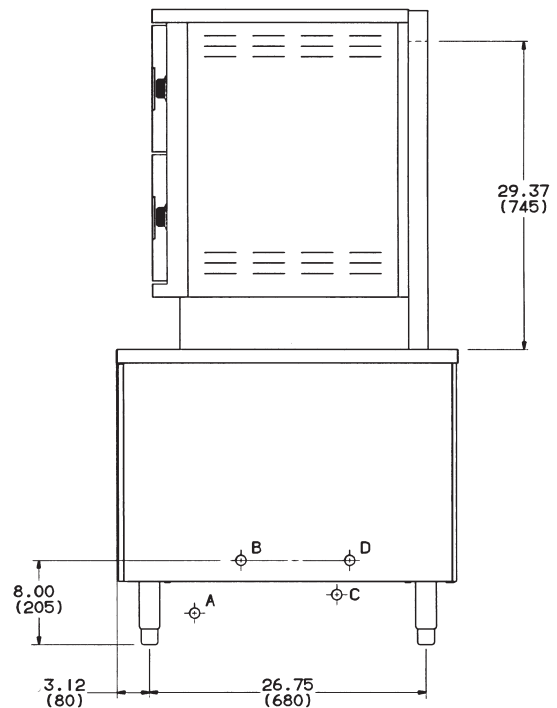
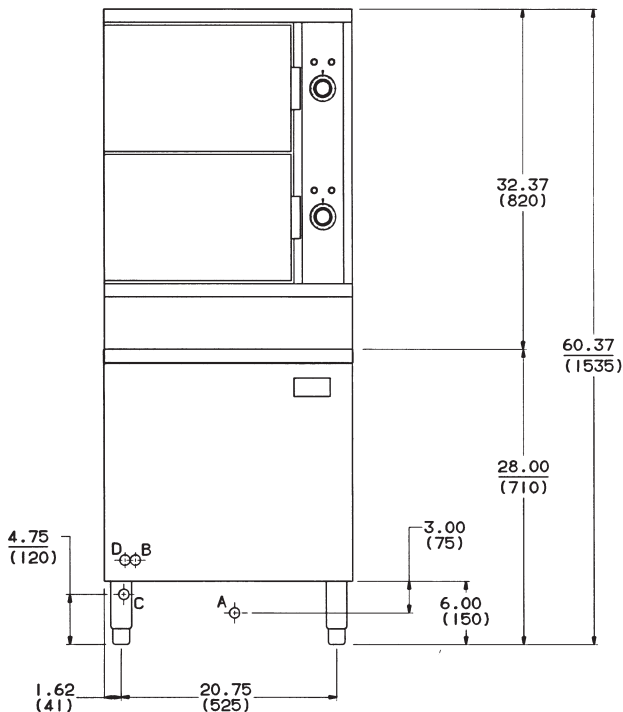

SERVICE CONNECTIONS GAS HEAT, VSX36G

FIG. 8

LEGEND

- A. GAS CONNECTION: 3/4" NPT.
- B. ELECTRICAL CONNECTION FOR CONTROLS: 120V/60HZ/1PH/300 WATT MAXIMUM, POWER SUPPLY WITH GROUNDING WIRE REQUIRED. (FOR OTHER THAN 120 VOLT SUPPLY CONSULT FACTORY FOR LOCATION OF THIS CONNECTION.)
- C. DRAIN: COMPARTMENT, BOILER AND EXHAUST GROUP APPROXIMATELY 3/2" IN DIAMETER. (PROVIDE AN OPEN AIR GAP TYPE DRAIN DIRECTLY UNDER UNIT FRAME. DO NOT CONNECT SOLIDLY TO ANY DRAIN CONNECTION.)
- D. COLD SUPPLY WATER CONNECTION: 1/2" NPT FOR BOILER DRAIN & COMPARTMENT DRAIN COLD WATER CONDENSERS, AND BOILER FEED.

NOTE: DIMENSIONS WHICH LOCATE THE ABOVE CONNECTIONS HAVE A TOLERANCE OF ± 3 IN. (± 75 MM). NORMAL DIMENSIONS ARE IN INCHES. DIMENSIONS IN () ARE IN MILLIMETERS.

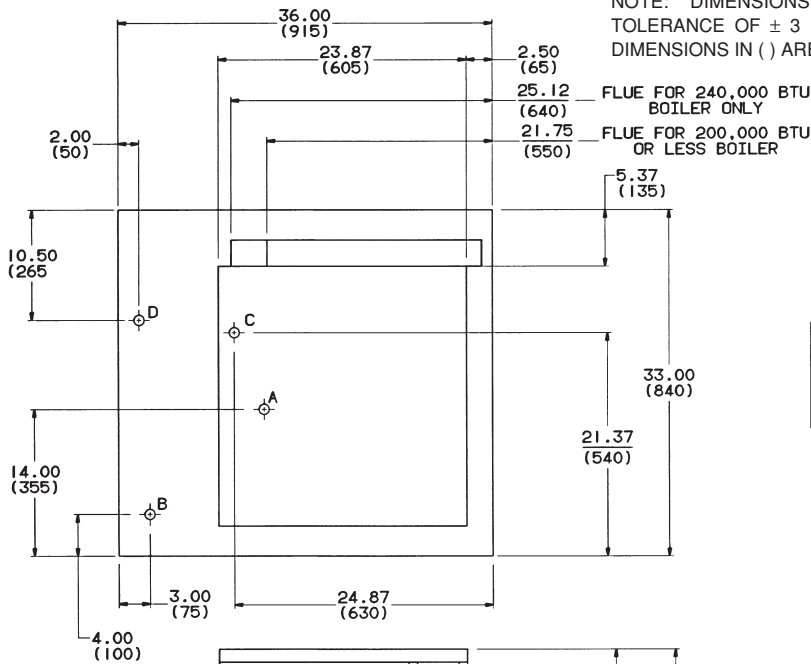

EQUIPMENT CLEARANCES TO COMBUSTIBLE CONSTRUCTION

REAR: 6 IN. MIN. (150 MM.)
LEFT SIDE: 6 IN. MIN. (150 MM.)
RIGHT SIDE: 6 IN. MIN. (150 MM.)

DIM. A1	
200,000 BTU OR LESS BOILER	240,000 BTU BOILER
14.00 (355)	10.00 (255)

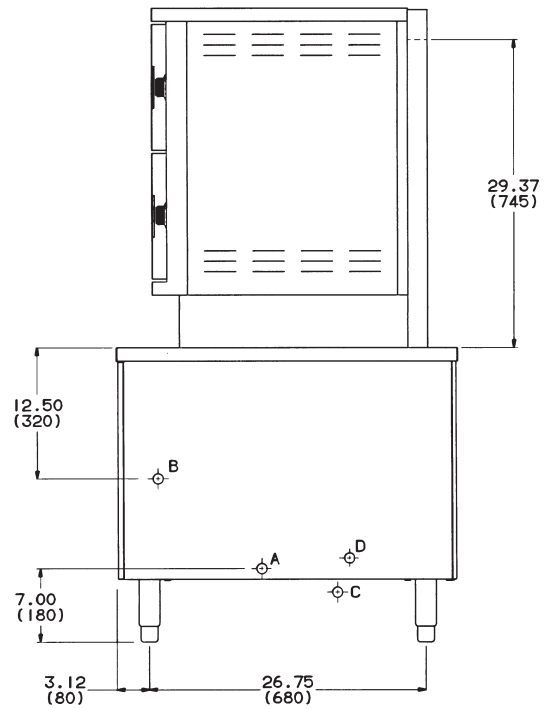
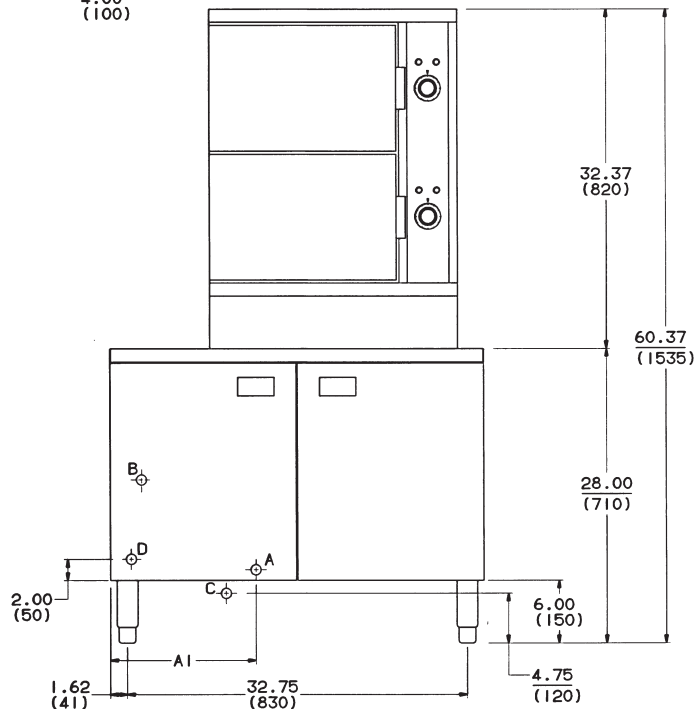

SERVICE CONNECTIONS GAS HEAT, VSX42GT

FIG. 9

LEGEND

- A. GAS CONNECTION: 3/4" NPT.
- B. ELECTRICAL CONNECTION FOR CONTROLS: 120V/60HZ/1PH/300 WATT MAXIMUM, POWER SUPPLY WITH GROUNDING WIRE REQUIRED. (FOR OTHER THAN 120 VOLT SUPPLY CONSULT FACTORY FOR LOCATION OF THIS CONNECTION.)
- C. DRAIN: COMPARTMENT, BOILER AND EXHAUST GROUP APPROXIMATELY 3/8" IN DIAMETER. (PROVIDE AN OPEN AIR GAP TYPE DRAIN DIRECTLY UNDER UNIT FRAME. DO NOT CONNECT SOLIDLY TO ANY DRAIN CONNECTION.)
- D. COLD SUPPLY WATER CONNECTION: 1/2" NPT FOR BOILER DRAIN & COMPARTMENT DRAIN COLD WATER CONDENSERS, AND BOILER FEED.

NOTE: DIMENSIONS WHICH LOCATE THE ABOVE CONNECTIONS HAVE A TOLERANCE OF ± 3 IN. (± 75 MM). NORMAL DIMENSIONS ARE IN INCHES. DIMENSIONS IN () ARE IN MILLIMETERS.

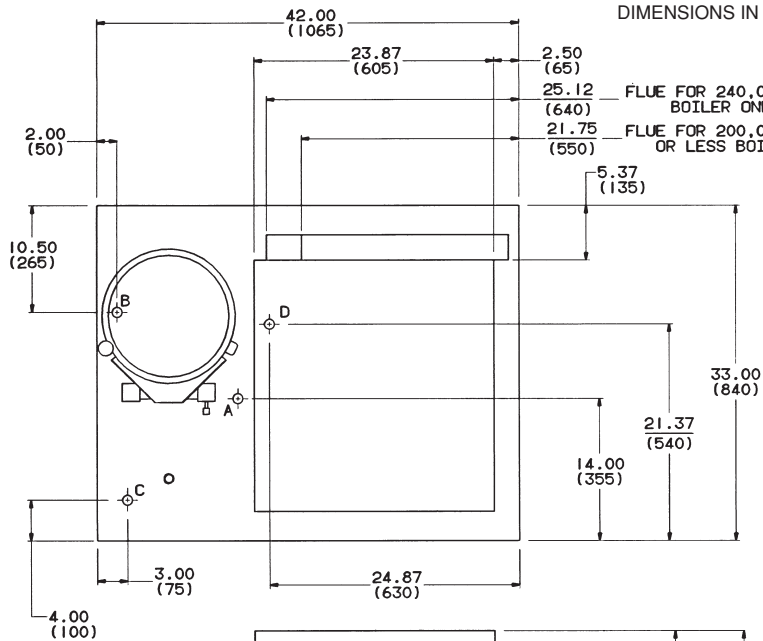

EQUIPMENT CLEARANCES TO COMBUSTIBLE CONSTRUCTION

REAR: 6 IN. MIN. (150 MM.)
LEFT SIDE: 6 IN. MIN. (150 MM.)
RIGHT SIDE: 6 IN. MIN. (150 MM.)

DIM. A1	
200,000 BTU OR LESS BOILER	240,000 BTU BOILER
14.00 (355)	10.00 (255)

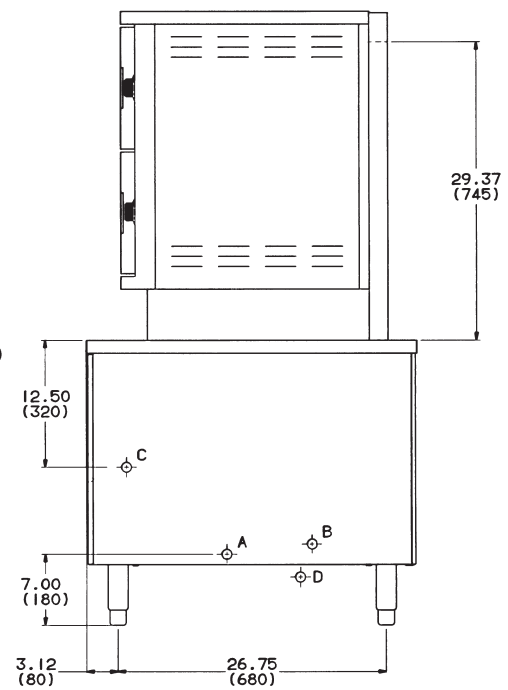
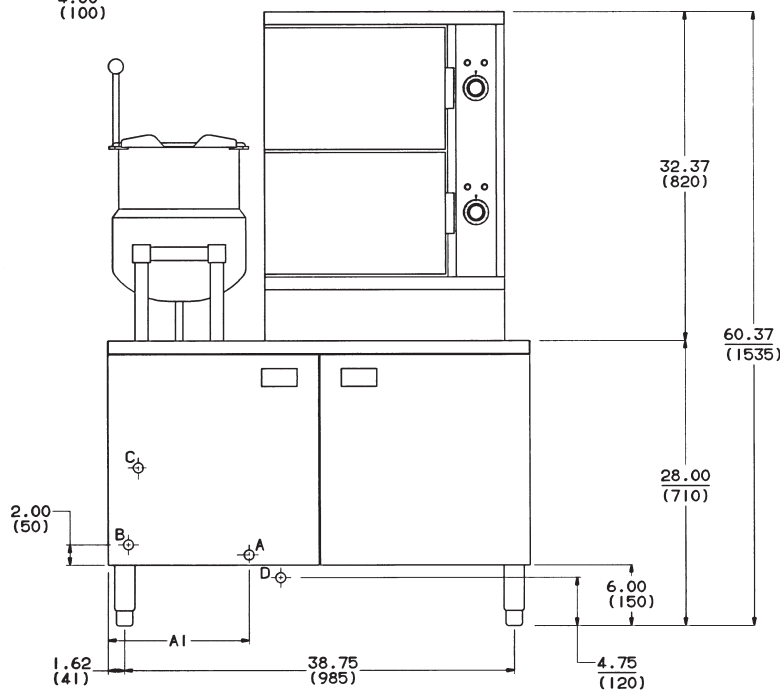

SERVICE CONNECTIONS ELECTRIC HEAT, VSX24E

FIG. 10

LEGEND

- A. JUNCTION BOX: J.I.C. 6X6X4 FOR ELECTRICAL SUPPLY CONNECTION FOR HEAT.
- B. ELECTRICAL CONNECTION FOR CONTROLS: 120V/60HZ/1PH/300 WATT MAXIMUM, POWER SUPPLY WITH GROUNDING WIRE REQUIRED. (NOT PROVIDED IF A STEP DOWN TRANSFORMER IS FURNISHED.)
- C. COLD SUPPLY WATER CONNECTION: 1/4" NPT FOR BOILER DRAIN AND COMPARTMENT DRAIN COLD WATER CONDENSERS.
- D. DRAIN: COMPARTMENT, BOILER AND EXHAUST GROUP APPROXIMATELY 3/8" IN DIAMETER. (PROVIDE AN OPEN AIR GAP TYPE DRAIN DIRECTLY UNDER UNIT FRAME. DO NOT CONNECT SOLIDLY TO ANY DRAIN CONNECTION.)

NOTE: DIMENSIONS WHICH LOCATE THE ABOVE CONNECTIONS HAVE A TOLERANCE OF ± 3 IN. (± 75 MM). NORMAL DIMENSIONS ARE IN INCHES. DIMENSIONS IN () ARE IN MILLIMETERS.

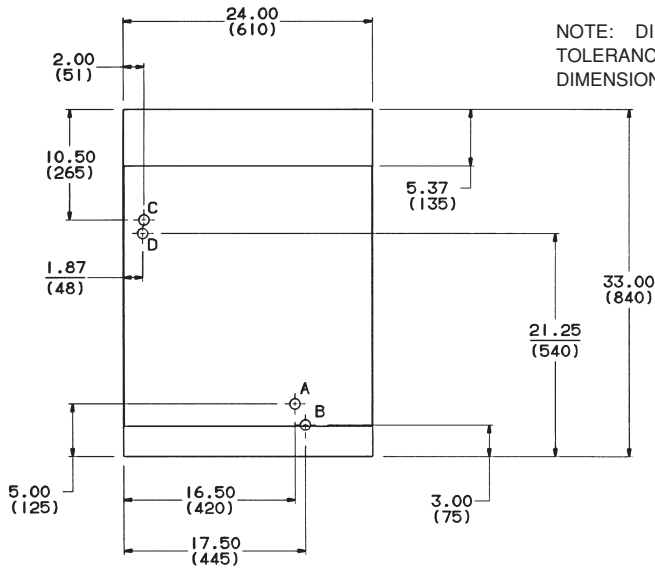

EQUIPMENT CLEARANCES TO COMBUSTIBLE CONSTRUCTION

REAR: 2 IN. MIN. (50 MM.)

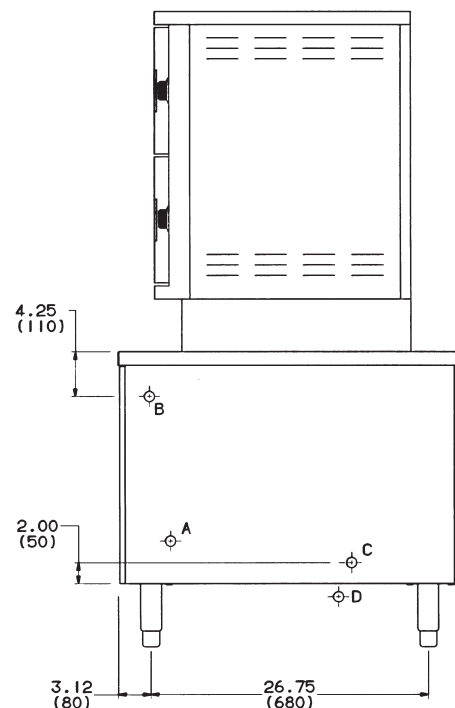
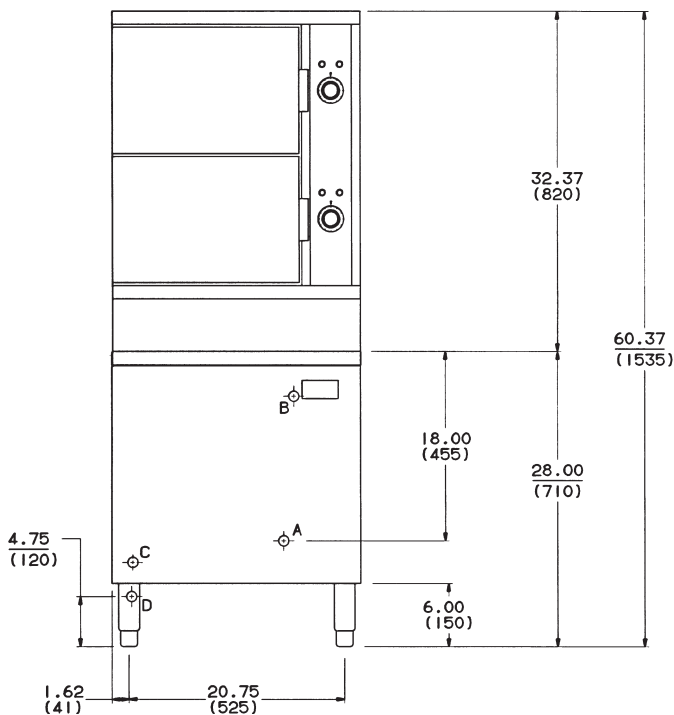

SERVICE CONNECTIONS ELECTRIC HEAT, VSX36E

FIG. 11

LEGEND

- A. JUNCTION BOX: J.I.C. 6X6X4 FOR ELECTRICAL SUPPLY CONNECTION FOR HEAT.
- B. ELECTRICAL CONNECTION FOR CONTROLS: 120V/60HZ/1PH/300 WATT MAXIMUM, POWER SUPPLY WITH GROUNDING WIRE REQUIRED. (NOT PROVIDED IF A STEP DOWN TRANSFORMER IS FURNISHED.)
- C. COLD SUPPLY WATER CONNECTION: 1/4" NPT FOR BOILER DRAIN AND COMPARTMENT DRAIN COLD WATER CONDENSERS.
- D. DRAIN: COMPARTMENT, BOILER AND EXHAUST GROUP APPROXIMATELY 3/8" IN DIAMETER. (PROVIDE AN OPEN AIR GAP TYPE DRAIN DIRECTLY UNDER UNIT FRAME. DO NOT CONNECT SOLIDLY TO ANY DRAIN CONNECTION.)

NOTE: DIMENSIONS WHICH LOCATE THE ABOVE CONNECTIONS HAVE A TOLERANCE OF ± 3 IN. (± 75 MM). NORMAL DIMENSIONS ARE IN INCHES. DIMENSIONS IN () ARE IN MILLIMETERS.

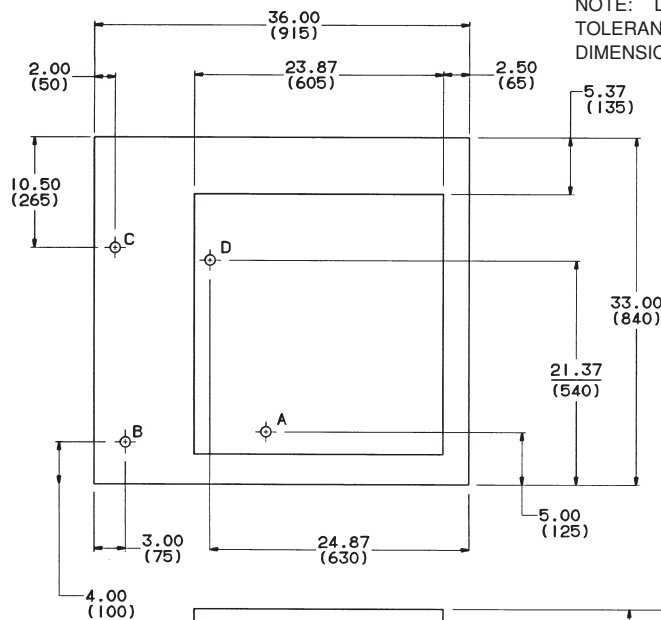

EQUIPMENT CLEARANCES TO COMBUSTIBLE CONSTRUCTION

REAR: 2 IN. MIN. (50 MM.)

DIM. A1	
18 OR 24 KW BOILER	36.42 OR 48 KW BOILER
16.50 (420)	10.62 (270)

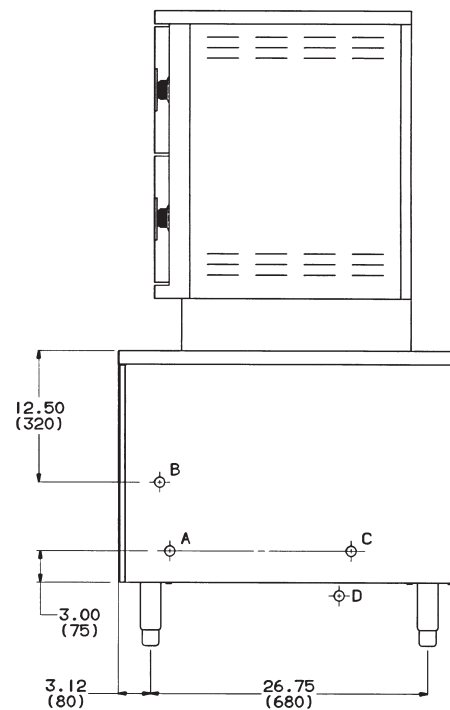
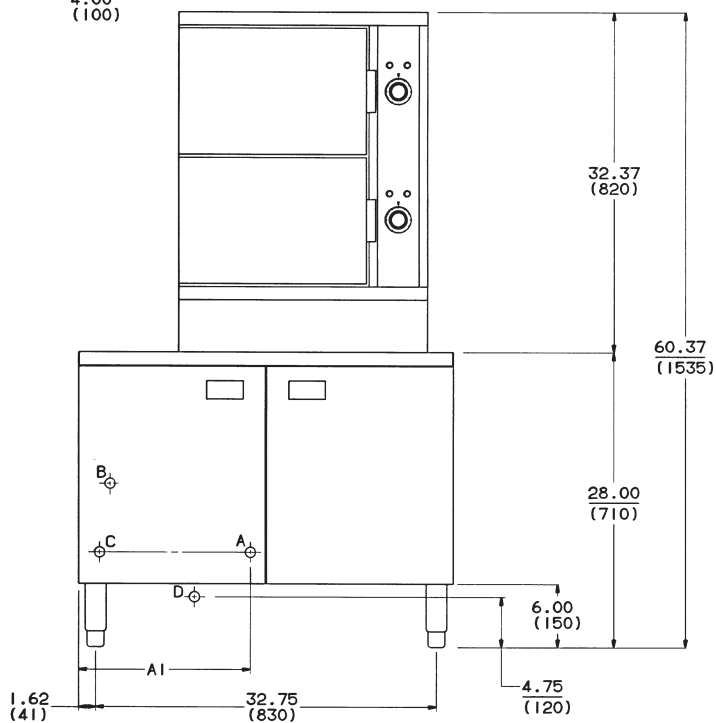

SERVICE CONNECTIONS ELECTRIC HEAT, VSX42ET

FIG. 12

LEGEND

- A. JUNCTION BOX: J.I.C. 6X6X4 FOR ELECTRICAL SUPPLY CONNECTION FOR HEAT.
- B. ELECTRICAL CONNECTION FOR CONTROLS: 120V/60HZ/1PH/300 WATT MAXIMUM, POWER SUPPLY WITH GROUNDING WIRE REQUIRED. (NOT PROVIDED IF A STEP DOWN TRANSFORMER IS FURNISHED.)
- C. COLD SUPPLY WATER CONNECTION: 1/4" NPT FOR BOILER DRAIN AND COMPARTMENT DRAIN COLD WATER CONDENSERS.
- D. DRAIN: COMPARTMENT, BOILER AND EXHAUST GROUP APPROXIMATELY 3/8" IN DIAMETER. (PROVIDE AN OPEN AIR GAP TYPE DRAIN DIRECTLY UNDER UNIT FRAME. DO NOT CONNECT SOLIDLY TO ANY DRAIN CONNECTION.)

NOTE: DIMENSIONS WHICH LOCATE THE ABOVE CONNECTIONS HAVE A TOLERANCE OF ± 3 IN. (± 75 MM). NORMAL DIMENSIONS ARE IN INCHES. DIMENSIONS IN () ARE IN MILLIMETERS.

EQUIPMENT CLEARANCES TO COMBUSTIBLE CONSTRUCTION

REAR: 2 IN. MIN. (50 MM.)

DIM. A1	
18 OR 24 KW BOILER	36, 42 OR 48 KW BOILER
16.50 (420)	10.62 (270)

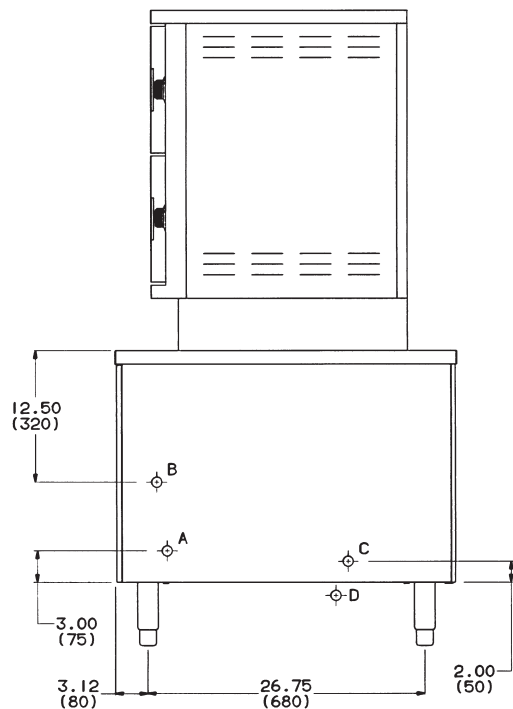
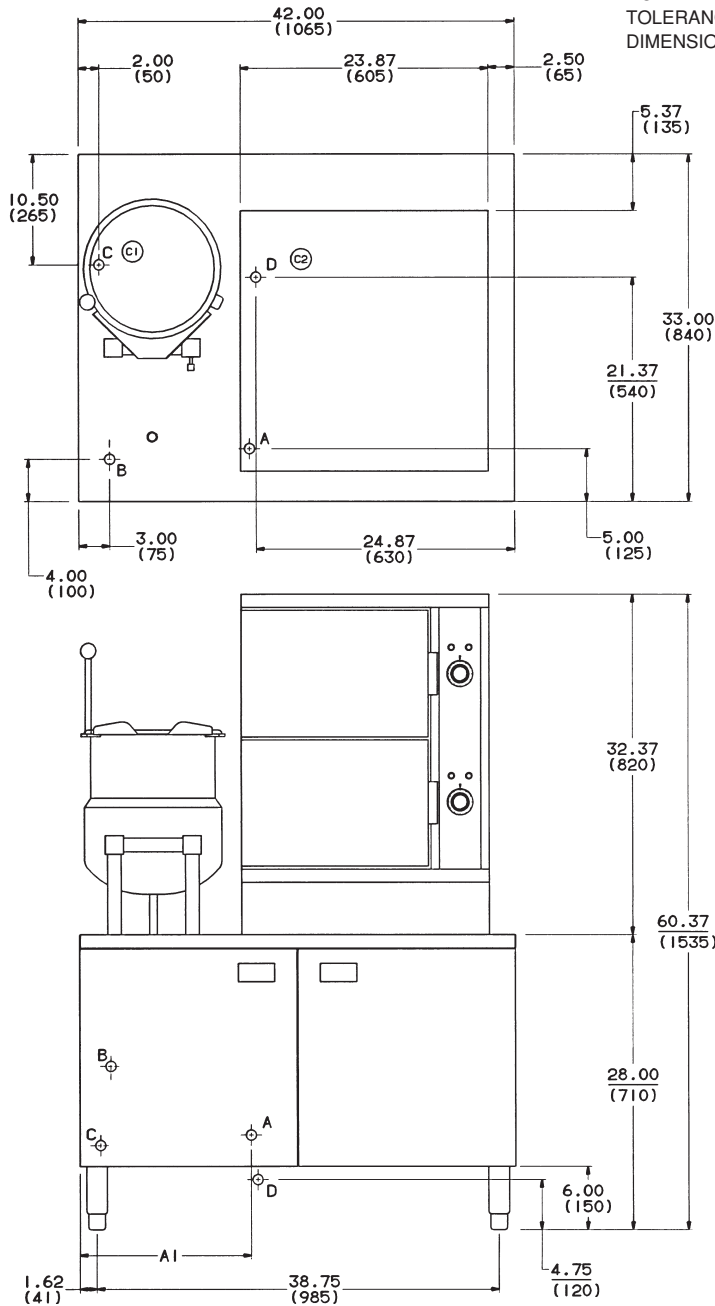

START-UP TEST RUN

After the appliance is installed and proper service connections have been made, thoroughly test the steam cooker before operation.

Gas Powered Steam Generator

1. Open manual gas shutoff valve, and if the appliance has a manual blowdown valve, close it. Open left cabinet door and turn water fill and power switch ON. The red light will come on and water will fill boiler to the required level in about 15 minutes. Observe water level gauge glass to verify. Both valves on gauge glass assembly must be open.
2. The dial on the gas combination control valve has three positions (On-Pilot-Off) for manual gas control of main burners and pilot. Turn dial on gas combination valve to PILOT. Depress dial and light pilot burner; maintain dial in depressed position for about 30 seconds and release. Observe that pilot burner flame stays on. If the flame should go out, wait 5 minutes before relighting.
3. Turn gas combination control valve dial to ON and burners will ignite. Steam generation will begin and be completed in about 15 minutes. Observe that the boiler pressure gauge indicates steam pressure in the range of 9-12 psi (9-13 psi if a kettle is connected to the steamer).
4. Set both timer knobs to "0". Open both compartment doors and observe that no steam has entered the cooking compartments. Close doors.
5. Set both timer knobs to 2 minutes. The READY lights will go off, the COOKING lights will come on, and steam will be heard entering the compartments.

After one minute, open each door and observe that steam has ceased to enter each compartment, but COOKING lights and cooking times at "01" are maintained.

WARNING: THE COOKING COMPARTMENTS CONTAIN LIVE STEAM. STAY CLEAR WHILE OPENING EACH DOOR.

7. Close doors. Steam generation and cook times will resume. Observe appliance drain that live steam from compartments is being cooled by cold water from the cold water solenoid valve.

8. When timer knobs are on "0", each buzzer will sound, steam generation will cease, COOKING lights will go off and READY lights will come on. To silence buzzers, turn timer knobs to OFF position.

9. During simulation of cooking cycle, burners will cycle on and off to maintain steam pressure in boiler.

10. Turn power switch OFF. Amber light will go out.

11. Blow down boiler (see BLOW DOWN BOILER in this manual).

Electrically Powered Steam Generator

1. If steamer has a manual blowdown valve, close it. Open left cabinet door and turn power switch ON. Water will fill boiler to the required level in about 15 minutes. Observe water level gauge glass to verify. Both valves on gauge glass assembly must be open. Steam generation will begin and be completed in about 15 minutes.

2. Set both timer knobs to "0". Open both compartment doors and observe that no steam has entered the cooking compartments. Close doors.

3. Set both timer knobs to 2 minutes. READY lights will go off, COOKING lights will come on, and steam will be heard entering the compartments.

After one minute, open each door and observe that steam has ceased to enter each compartment, but COOKING lights and cooking times at "01" are maintained.

WARNING: THE COOKING COMPARTMENTS CONTAIN LIVE STEAM. STAY CLEAR WHILE OPENING EACH DOOR.

4. Close doors. Steam generation and cook times will resume. Observe appliance drain that live steam from compartments is being cooled by cold water from the cold water solenoid valve.

5. When timer knobs are on "0", each buzzer will sound, steam generation will cease, COOKING lights will go off and READY lights will come on. To silence buzzers, turn timer knobs to OFF position.

6. During simulation of cooking cycle, the heating elements will cycle on and off to maintain steam pressure in the boiler.

7. Turn power switch OFF. Amber light will go out.
8. Blow down boiler (see BLOW DOWN BOILER in this manual).

Direct Steam Powered Cooker

1. Set both timer knobs to "0". Open both compartment doors and observe that no steam has entered cooking compartments. Close doors.
2. Set both timer knobs to 2 minutes. READY lights will go off, COOKING lights will come on, and steam will be heard entering the compartments.

After one minute, open each door and observe that steam has ceased to enter each compartment, but COOKING lights and cooking times at "01" are maintained.

WARNING: THE COOKING COMPARTMENTS CONTAIN LIVE STEAM. STAY CLEAR WHILE OPENING EACH DOOR.

3. Close doors. Steam generation and cook times will resume. Observe appliance drain that live steam from compartments is being cooled by cold water from the cold water solenoid valve.
4. When timer knobs are on "0", each buzzer will sound, steam generation will cease, COOKING lights will go off and READY lights will come on. To silence buzzers, turn timer knobs to OFF position.

Regenerative Steam Powered Generator

1. If the steamer has a manual blowdown valve, close it. Turn power switch ON. Water will fill the boiler to the required level in about 15 minutes. Observe water level gauge glass to verify. Both valves on gauge glass assembly must be open. Steam generation will begin and be completed in about 15 minutes.
2. Set both timer knobs to "0". Open both compartment doors and observe that no steam has entered the cooking compartments. Close doors.

3. Set both timer knobs to 2 minutes. READY lights will go off, COOKING lights will come on, and steam will be heard entering the compartments.

After one minute, open each door and observe that steam has ceased to enter each compartment, but COOKING lights and cooking times at "01" are maintained.

WARNING: THE COOKING COMPARTMENTS CONTAIN LIVE STEAM. STAY CLEAR WHILE OPENING EACH DOOR.

4. Close doors. Steam generation and cook times will resume. Observe appliance drain that live steam from compartments is being cooled by cold water from the cold water solenoid valve.
5. When timer knobs are on "0", each buzzer will sound, steam generation will cease, COOKING lights will go off and READY lights will come on. To silence buzzers, turn timer knobs to OFF position.
6. During simulation of cooking cycle, steam coils will cycle on and off to maintain steam pressure in the boiler.
7. Turn power switch OFF. Amber light will go out.
8. Blow down boiler (see BLOW DOWN BOILER in this manual).

BLOW DOWN BOILER

Always blow down boiler when boiler is under maximum pressure and no steam is being used.

Automatic Blowdown

Turn power switch OFF. Depress blowdown button. Blowdown timer will operate for 4 minutes. At end of blowdown, turn fill switch to ON and allow boiler to fill.

Manual Blowdown

Turn power switch OFF. Open blowdown valve. After boiler has drained completely, close blowdown valve and turn fill switch to ON and allow boiler to fill.

OPERATION

WARNING: THE STEAMER AND ITS PARTS ARE HOT. USE CARE WHEN OPERATING, CLEANING OR SERVICING THE STEAMER. THE COOKING COMPARTMENTS CONTAIN LIVE STEAM. STAY CLEAR WHILE OPENING EACH DOOR.

CONTROLS — CABINET BASE GENERATOR (Fig. 13)

Handhole Cover Assembly — when unbolted and removed, allows internal examination and cleaning of boiler if required.

Water Level Gauge Assembly — permits visual confirmation that water level is being maintained in the boiler during operation. The correct water level is a point one-half of the height of the glass. The manual valves at the top and bottom of this assembly must be fully open, and only closed if the glass tube should be damaged.

Observe that the water is clean and clear in the glass tube. The appearance of extreme murkiness in the water indicates inadequate water quality and will cause failure of controls and the steamer. Warranty does not cover malfunction due to poor water conditions. Blow down and/or clean the generator.

Pilot Burner (Gas Base Generator Only) — should remain lit at all times unless the steamer will not be in use for an extended period of time. If at any time the flame goes out, wait 5 minutes before relighting.

Main Burners (Gas Base Generator Only) — cycle on and off to maintain steam pressure in the boiler.

Gas Combination Control Valve (Gas Base Generator Only) — regulates flow of gas to burners.

Low Water Cutoff/Automatic Fill Control — Level Sensing Probes — these controls allow the feed water to enter the generator when the water level is low. They will also shut off the heat source to the boiler if the water level drops too low. The level sensing probes may be easily removed to inspect for lime build-up. As a rule, the condition of these devices will indicate the overall water condition of the boiler. Clean the probes if needed. **Controls may not function and serious clogging will occur if a daily blowdown procedure is not followed.**

Drain Solenoid Valve — a quick acting drain valve provided for daily blowdown of the generator.

Strainers — a strainer is used in the water inlet line to prevent foreign matter from becoming lodged in the inlet solenoid valve. A “Y” strainer is inserted upstream of the drain solenoid valve to allow the valve to operate smoothly. A strainer is used in the pressure regulating valve on models using direct steam supply.

Boiler Fill Solenoid Valve — admits water to the boiler when demanded by the automatic fill controls in order to maintain the correct water level in the steam generator.

Blowdown Drain CWC Solenoid Valve — allows cold water to flow to boiler blowdown drain and helps cool the boiler water prior to its discharge into the drain.

Cycling Pressure Switch — controls boiler pressure between prescribed limits by turning the heat source on and off. A back-up switch of identical design is provided and has a higher high setting and a lower low setting than the primary control.

Power Switch — when turned ON will automatically begin the steam generating process in the boiler. The power switch is fastened to the front face of the generator control box.

Pressure Regulating Valve — used to control manifold steam pressure at 10-12 psi on models using direct steam supply.

Water Inlet Ball Valve — water service valve which can be used to stop water flow to the steamer when the steamer is being serviced.

High Limit Thermostat — a protective device which shuts off the gas or electric power if the boiler overheats.

Descaler — hangs submerged in water inside the generator and helps control scaling.

Drain — drains steam condensate and water from cooking compartments and boiler.

Boiler Blowdown Valve — plumbed to the drain pipe of the boiler, and when specified as automatic, will be a solenoid (electrically operated) valve which will close to assist in maintaining proper water level in the boiler and open whenever the steamer is turned off to blow down sediment and scalant that may be lodged in the chamber of the boiler.

Pressure Gauge — indicates boiler steam pressure. Normal operating pressure range is 9-12 psi for the steamer, or 9-13 psi if a kettle is connected to the steamer.

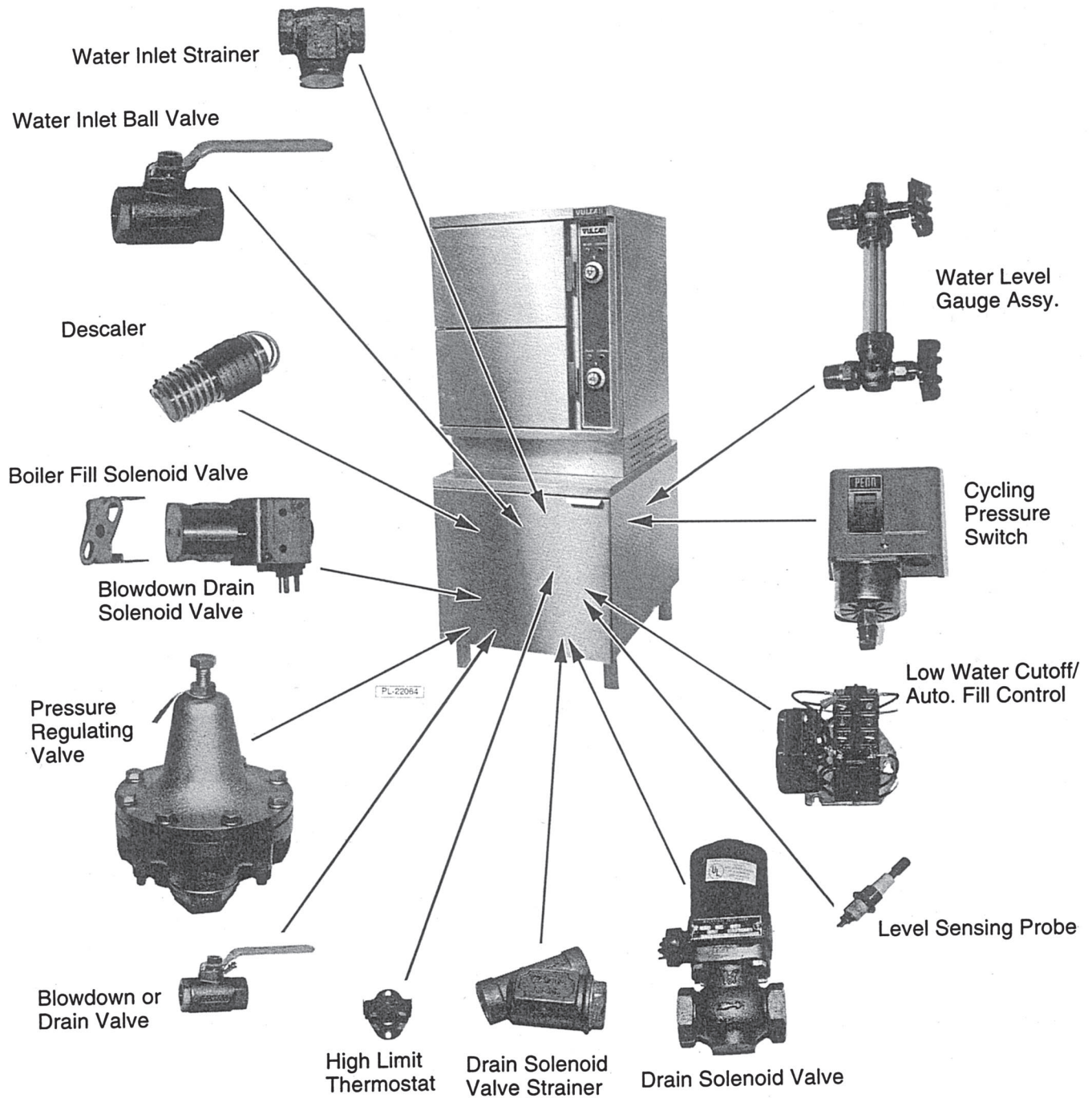

Fig. 13

CONTROLS — COMPARTMENT (Fig. 14)

The upper section of the steamer consists of two cooking compartments. Each compartment functions independently with its own controls, and is a separated, sealed steam chamber during the cooking operation.

Gasket Plate Screw (Not Shown) — a stainless steel screw on the gasket plate immediately adjacent to each corner of the gasket allows adjustment of the gasket if necessary.

Door Gasket (Not Shown) — provided on each compartment door and ensures proper sealing of the cooking compartment. **CAUTION: Damage to the gasket sealing surface, such as nicks or cuts, will cause steam leakage.**

Door Striker (Not Shown) — provides positive latching of door.

Ready Light (Green) — when lit, indicates appliance is ready for the cooking cycle.

Cooking Light (Red) — when lit, indicates appliance is in the cooking phase.

Timer — use to set desired cooking cycle time. Timer range is 0-60 minutes.

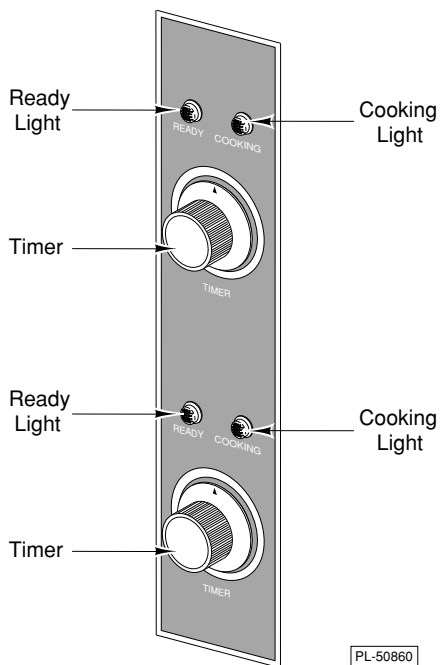

Fig. 14

LIGHTING THE STANDING PILOT (GAS BASE GENERATORS ONLY) (On Steamers So Equipped)

1. Before lighting the pilot, both the burner and the pilot must have been off for at least 5 minutes.
2. Turn power switch (upper left of generator cabinet) to OFF. Be sure gas to the steamer is turned ON.
3. Turn knob of combination control valve to PILOT. With a lit taper, ignite pilot while depressing knob of combination control valve. Keep knob depressed for about 1 minute after pilot is lit.
4. Release knob. Pilot should continue burning. If not, repeat Steps 1 through 3.
5. Turn knob counterclockwise to ON.

Shutdown

1. Turn gas service valve and power switch OFF.
2. Close water inlet valve.

OPERATING STEAMERS WITH INTERMITTENT PILOTS (GAS BASE GENERATORS ONLY)

1. Before lighting the pilot, both the burner and the pilot must have been off for at least 5 minutes. Do not attempt to manually light the pilot.
2. Turn knob of gas combination control valve counterclockwise until it stops at the ON position.
3. Turn boiler power switch to ON position (light on).
4. The electrode will begin sparking and pilot will light.
5. Ensure pilot light has lit by observing pilot flame.
6. The pilot light will remain lit as long as the boiler power switch is in the ON position.
7. The cycling pressure switch will open and close the gas combination control valve, which will in turn cycle the main burner.

Shutdown

1. Turn the boiler power switch to the OFF position to extinguish the pilot light.
2. To make the pilot light and main burners inoperable, turn the gas combination control valve clockwise until it stops (OFF position).
3. To completely shut off pilot light and main burners, close the main gas valve.

DAILY STARTING PROCEDURE

1. If boiler has manual blowdown drain valve, close it.
2. On gas powered generators, ensure that pilot burner flame is ON. If flame is out, a 5-minute period of complete shutoff of gas supply is required before relighting.
3. Turn power switch ON.
4. Wait 20 minutes before starting cooking operation.
5. This step is required only when the cooking chamber is cold or when cooker is first used for the day. When READY light is on, preheat cooking compartment(s) for 1 minute. Turn timer knob to "1". READY light will go off and COOKING light will come on. Make sure door is closed. When buzzer sounds, open and close door to silence buzzer.
6. With compartment(s) preheated and READY light on, place pans of food into cooking compartment and shut door. Refer to COOKING CHART in this manual and set desired cooking time.
7. Turn timer knob to desired cooking time. Cooking cycle will begin.

Cooking cycle may be interrupted at any time by opening door and resumed again by closing door.
8. The buzzer will sound when the cooking cycle ends and no more steam is entering the cooking compartment(s). The buzzer must be silenced by opening the door. Remove cooked food. The COOKING light will go off and the READY light will come on indicating the cooker is now ready for the next cooking cycle.

CLEANING

Never use steel wool on stainless steel surfaces. Never apply food oils or petroleum lubricants directly to the door gasket.

Daily

At the end of each day, or more often if necessary, turn steamer OFF and allow compartments to cool. Remove pans and side racks from compartments and clean in a sink.

Remove food sediment from compartment bottoms. Wipe all solids away from the drain opening, especially any large particles, to prevent possible clogging of the drain.

Clean the drain screen at least daily, or more often if required. Remove drain screen by pulling straight out. Clean drain screen in a sink.

Wash compartment interiors with mild detergent. Rinse thoroughly and wipe dry with a soft clean cloth. Replace racks.

After cooking grease-producing foods, pour one-half gallon of soapy water down the drain and rinse with one-half gallon of hot clear water.

For maximum gasket life, wash gasket sealing surface of compartment doors with mild detergent to remove harmful food acids. Follow with a warm water rinse to remove all traces of detergent. Then wipe with a soft, dry cloth. Leave the door slightly open when not in use.

Use a clean damp cloth to wipe down the exterior. Polish with a soft dry cloth. Remove discolorations with a non-abrasive cleaner.

If the water in the sight glass becomes extremely murky, the generator should be blown down and/or cleaned.

As Required

After a period of time, all gas burners accumulate carbon in their ports and this restricts performance. To clean burners, boil them in a strong solution of lye water for ½ hour. Then clean gas ports with a sharp pointed metal instrument to ensure open ports. Clean as needed (usually about once a year will be often enough).

Remove the “Y” strainer upstream of the drain solenoid valve by unscrewing the cap on the section protruding down towards the floor. Remove the screen and any foreign particles. Rinse the screen thoroughly and replace. Replace cap.

The pressure regulating valve strainer will become clogged if dirty steam lines are connected to direct steam models. Remove the hex nut on the bottom of the pressure regulating valve to clean the strainer and valve seat.

MAINTENANCE

WARNING: THE STEAMER AND ITS PARTS ARE HOT. USE CARE WHEN OPERATING, CLEANING OR SERVICING THE STEAMER. THE COOKING COMPARTMENTS CONTAIN LIVE STEAM. STAY CLEAR WHILE OPENING EACH DOOR.

DOOR GASKET

If door gasket is nicked or cut or at the end of its useful life, it must be replaced. Damage to the gasket sealing surface will cause steam leakage.

However, if a leak occurs in one corner only and gasket appears serviceable, turn the stainless steel screw on the gasket plate immediately adjacent to the leaking corner one-half turn counterclockwise. Do not attempt excessive turning of screws since misalignment of door is likely.

BOILER BLOWDOWN VALVE

Turn the steamer off at least once daily and blow down the boiler in order to remove sediments, scalants and lime build-up in the boiler. If the steamer is supplied with a manual valve, open it daily when the steamer is shut down. The manual blowdown valve is located on the bottom front of the cabinet base.

DESCALER

Inspect the descaler every three months. Replace it when it has shrunk to one-half its original size. Local water conditions generally determine the life of the descaler.

LEVEL SENSING PROBES

Inspect level sensing probes for lime build-up once a month. Clean probes if needed.

WATER LEVEL GAUGE ASSEMBLY

Check sight glass assembly daily. Extreme murkiness indicates the generator should be blown down and/or cleaned, and is an indication of bad water conditions. The correct water level is a point one-half of the height of the glass.

FLUE (GAS BASE GENERATOR ONLY)

Annually check the flue when cool to be sure it is free of obstructions.

Contact your Vulcan-Hart service representative for any other maintenance required.

COOKING CHART

The following table lists suggested cooking times and weights. These times, which will vary depending on initial product temperature, size, shape, etc., are approximate and should be adjusted to suit your operation.

PRODUCTS TO BE COOKED IN SOLID PANS

PRODUCT	TIMER SETTING IN MINUTES	WEIGHT PER PAN
Eggs, Scrambled	10-12	8 Dozen
Rice, Long Grain (Cover with 4 cups water/lb.)	25	2 Lb.
Pasta (Place perforated pan inside solid pan, cover pasta with cold water) Spaghetti - Regular/Vermicelli Macaroni - Shells/Elbows Noodles - ½" Wide Lasagna Noodles	12-15 15-18 12-15 15-18	
Frozen Casseroles, Lasagna	35	Full Pan
Meat Loaf, 3-5 Lb. Each	40	15 Lb.
Beef Ground Chuck Sliced as Purchased	20-25 35-40	10 Lb. 10 Lb.
Shrimp, Frozen, 10 Shrimp per Lb.	5	4 Lb.
Beans Baked Refried	9 9	10 Lb. Can 10 Lb. Can
Canned Vegetables	6	10 Lb. Can
Prunes, Dried	12-15	

PRODUCTS TO BE COOKED IN PERFORATED PANS

PRODUCT	TIMER SETTING IN MINUTES	WEIGHT PER PAN
Clams Frozen Fresh, Cherrystone	10-12 5-6	3 Dozen 3 Dozen
King Crab, Frozen Claws Legs	4 4-6	2½ Lb. 4½ Lb.
Lobster Tail, Frozen Lobster, Live, 10"-12"	6 5	10 Lb. 4 Per Pan

PRODUCTS TO BE COOKED IN PERFORATED PANS (Cont'd.)

PRODUCT	TIMER SETTING IN MINUTES	WEIGHT PER PAN
Salmon Fillets, Frozen, 8 Oz. Ea.	5	7½ Lb.
Scallops, Fresh	4	3 Lb.
Scrod Fillets, Fresh	3-5	4 Lb.
Eggs Hard Cooked Soft Cooked Soft Yoke for Caesar Salad	15 9-10 6-8	4 Dozen 4 Dozen 4 Dozen
Chicken, Breasts, Legs, Thighs	20	15 Lb.
Turkey, Frozen Breasts (2) Cut Lengthwise	90 55	6-7 Lb. Ea. 20-25 Lb.
Corned Beef	40-75	6-8 Lb.
Hot Dogs or Wieners	3	80-100 Count
Asparagus Spears Frozen Fresh	10-12 5	3 Dozen 5 Lb.
Beans Green, 2" Cut, Frozen/Fresh Lima, Frozen Baby Lima, Frozen	6 8 5	5 Lb. 5 Lb. 5 Lb.
Broccoli Spears, Frozen Spears, Fresh Flowerettes, Frozen	8 6 6	4 Lb. 5 Lb. 5 Lb.
Brussel Sprouts, Frozen	6	5 Lb.
Cabbage, Fresh, 1/6 Cut	8	5 Lb.
Carrots Baby Whole, Frozen Crinkle Cut, Frozen Sliced, Fresh	8 7-8 11	7 Lb. 4 Lb. 9 Lb.
Cauliflower, Flowerettes Frozen Fresh	6 7-8	4 Lb. 5 Lb.
Celery, 1" Diagonal Cut	7	5 Lb.

PRODUCTS TO BE COOKED IN PERFORATED PANS (Cont'd.)

PRODUCT	TIMER SETTING IN MINUTES	WEIGHT PER PAN
Corn		
Yellow Whole Kernel, Frozen	5	5 Lb.
Cobbettes, Frozen	8	27 Ears
	16-18	80 Ears
Corn-On-Cob, Fresh	10-12	18 Ears
	16-18	54 Ears
Peas, Green	6	5 Lb.
Potatoes, Whole Russet	55	10 Lb.
Spinach		
Chopped, Frozen	17	6 Lb.
Defrosted	5	6 Lb.
Fresh Cut	3	2 Lb.
Squash, Acorn, Halves	25	10 Halves
Zucchini, Slices	8	10 Lb.
Frozen Mixed Vegetables	6-7	5 Lb.
Fruit, Blanch for Peeling		
Grapefruit	3	
Oranges		
Pineapple, Whole for Cutting	4	

COOKING HINTS

Where possible, spread food out evenly in pans. Do not allow food to protrude above pans, since this will interfere with steam circulation between pans in the compartment.

Always preheat compartments for satisfactory results.

When time does not allow for defrosting of frozen vegetables, such as loose-pack peas, corn, diced carrots, etc., they may be cooked at once provided just half of the suggested portions in the cooking chart are used.

TROUBLESHOOTING

PROBLEM	CAUSE	CORRECTIVE MEASURES
Steamer Will Not Heat or Build Pressure	1. Problem with low water cut-off.	Replace low water cut-off control.
	2. Problem with pressure switch.	Replace pressure switch.
	3. Loose wiring.	Check against diagram and tighten connections.
	4. Problem with combination control valve on gas base generator.	Replace valve.
	5. Problem with pressure reducing valve on steam generator.	Clean strainer on pressure reducing valve and adjust to spec or replace.
	6. Problem with pressure gauge.	Replace gauge.
	7. Problem with contactor on electric generator.	Replace contactor.
	8. Problem with auto blow-down control on steamers so equipped.	Replace auto blow-down control.
	9. Problem with heat switch.	Replace heat switch.
	10. Problem with heating elements.	Replace heating elements.
	11. Pressure control set too high and operating on back-up.	Adjust to specification. Some high input units may need to be set below spec to compensate for overshoot.
	12. Pilot not lit on gas generators.	Light pilot. See lighting instructions in this manual.
	13. Generator not filling.	Check fill valve and water level controls.
	14. Power/steam/gas off to steamer.	Check that power, steam or gas supply is on.
Pilot Won't Light	1. Problem with combination control valve.	Replace combination control valve.
	2. Gas leak in pilot tubing.	Tighten.
	3. Obstruction in gas line or combination control valve.	Locate and remove obstruction.
	4. Pilot flame adjusted too small.	Adjust pilot flame.
	5. Thermocouple not completely inserted into holder.	Push thermocouple completely into holder.
Generator Leaks Water	1. Problem with boiler hand hole gasket.	Tighten or replace gasket.
	2. Problem with fitting on water or steam lines.	Tighten or replace fitting.
	3. Leak at gauge glass.	Replace gauge glass and seals.

PROBLEM	CAUSE	CORRECTIVE MEASURES
Compartment Won't Heat	1. Loose or misadjusted door switch striker.	Adjust and tighten bracket on door.
	2. Boiler not building pressure.	Adjust pressure switch.
	3. Problem with steam solenoid valve.	Replace steam solenoid valve.
Generator Off, Won't Heat	1. No electric power to controls.	Check connections.
	2. No fuel supply to steamer (steam to steam heated generator, gas to gas heated generators, power to heating elements).	Examine physical plant for flow problems.
	3. Problem with pressure switch.	Check pressure switch.
	4. Water level too low.	Turn water supply on, or check for stuck water feeder.
	5. Problem with low water cut-off.	Check low water cut-off for operation.
	6. On gas heated generator only, burner ignition pilot out (due to drafts, problem with combination control valve or interruption of gas supply).	Check around unit for drafts, or vapor from drain causing pilot outage.
	7. Open circuit or short in control circuit.	Check wiring.
Generator Water Level Too High	1. Water feeder solenoid valve not closing properly.	Clean or replace water feeder solenoid valve.
Generator Steam Pressure Too High (Pressure Relief Valve Leaking), or Too Low (Below 10 psi When Controls Cut Heat Off)	1. Problem with pressure switch.	Properly set Hi-Lo limits on pressure switch.
Steam Output Low as Compared to Usual Generator Performance	1. For cause and cure, see CABINET BASE GENERATOR in the Service section of this manual.	Check for blockage in fuel or steam line.
Door Won't Stay Closed	1. Door liner spring adjusted too tightly.	Lift liner out of door and bend springs to loosen.
	2. Latch out of adjustment or loose.	Adjust latch and tighten.
	3. Latch worn.	Dress retaining surface of latch or replace.
	4. Striker plate out of adjustment.	Adjust plate to obtain good latching.

PROBLEM	CAUSE	CORRECTIVE MEASURES
Steam Leak Around Door	1. Worn gasket.	Replace gasket.
	2. Drain line obstructed or not to an open gap drain.	Clean or open drain line.
	3. Cold water condenser not spraying properly.	Check solenoid valve and spray nozzle for proper operation. Replace as required.
	4. Door liner needs adjustment.	Lift off door liner and adjust pressure springs to obtain uniform seal.
Heat Coming On Without Water (Dry Firing)	1. Dirty low water cut-off probes.	Remove probes and clean insulator with soft clean cloth.
	2. Retention of water in probe housing.	Remove housing or housing cover and mechanically clean interior.
	3. Sticking low water cut-off contactor.	Replace contactor.
Pressure Gauge Not Working	1. Problem with pressure gauge.	Replace pressure gauge.
	2. Tubing crimped, plugged or broken.	Repair or replace tubing.
Steam Leaking Inside Unit	1. Problem with fitting or valve.	Tighten or replace fitting or valve.
	2. Steam pressure too high.	Adjust pressure switches.

SERVICE

These service procedures should only be performed by a qualified servicer.

WARNING: THE STEAMER AND ITS PARTS ARE HOT. USE CARE WHEN OPERATING, CLEANING OR SERVICING THE STEAMER. THE COOKING COMPARTMENTS CONTAIN LIVE STEAM. STAY CLEAR WHILE OPENING EACH DOOR.

WARNING: BEFORE SERVICING, DISCONNECT ELECTRICAL POWER SUPPLY AND PLACE A TAG AT THE DISCONNECT SWITCH TO INDICATE THAT YOU ARE WORKING ON THE CIRCUIT. TURN WATER SUPPLY OFF, RELIEVE LINES OF PRESSURE AND ALLOW HOT PARTS TO COOL.

COOKING COMPARTMENT

CONTROLS

For access to compartment controls, remove two screws holding compartment control panel and remove control panel.

Check for failure of the control circuit in the following order:

1. Check that electric power is reaching control circuit through compartment switch when it is turned ON.
2. On electric heat models with a transformer, check step down transformer for proper operation.
3. Check limit switch, operated by a tab on the compartment door, for proper function.
4. Check that timer switches are functioning as shown on the wiring diagram.
5. Check that timer motor operates when connected to power.

If problem is found in timer, replace it; do not take timer apart.

6. Check wiring for damaged insulation (no short circuit).

7. Check that all connections and terminals are securely fastened (no open circuits).

8. Check that all connections are made according to compartment control wiring diagram.

WATER ACCUMULATION ON BOTTOM OF COMPARTMENT

Water accumulation on the bottom of the cooking compartment(s) is primarily condensed steam. Failure to drain out quickly and completely may be due to clogged debris on the compartment drain screen. Pull screen straight out and thoroughly clean, then replace.

Failure to drain completely may also be due to improperly levelled steamer.

COOKING CYCLE CANNOT BE ACTIVATED

Inspect all wire terminations to ensure they are positive and secure before assuming any other problem.

When power switch on base generator is ON, set the timer knob to 2 minutes. Both READY lights should go off, COOKING lights should come on and steam should be entering both compartments.

CABINET BASE GENERATOR

ALL GENERATORS

Removal of Scalants From Boiler

It is recommended that the boiler be thoroughly inspected on at least three-month intervals, and more frequently in hard water areas and/or for units heavily used. This inspection consists of an internal examination and cleaning of the generator shell, an examination and possible replacement of the descaler, a check of lime build-up on the level sensing probes, and a check of all generator controls, including the pressure switches.

Local water conditions may cause excessive boiler scale build-up and cause the generator and compartment controls not to work. Proper periodic service must be performed as outlined in the operating and service instructions. It may also be necessary to install a water conditioner on the generator water feed. Contact your local water conditioner dealer.

Inspect and Clean Inside of Generator Shell

Flush (blow down) steam generator. Drain water from the shell with the electric power OFF (no heat on). Hold the pressure relief valve open to allow air to enter for better drainage.

Remove generator hand hole cover (top front of shell) by removing the nut and clamp, then tapping the cover lightly to free it while holding the cover stud (this prevents cover from dropping into generator). When replacing cover, clean gasket seating surfaces. Always use a new cover gasket.

Use wire brushes to free the scale. Loose material must be either scooped from the steam generator or flushed through the drain.

A suitable agent for removing lime may be used to remove scale build-up, but use caution to avoid damage to brass and copper parts of generator controls, etc.

If a solvent is used, it is recommended that the generator be removed (see REMOVING GENERATOR ASSEMBLY), the descaler, sensing probes and heating elements or steam coils, if furnished, be removed, and that the shell be stood on its end and filled with the solvent. One solvent commonly used for removing lime is muriatic (hydrochloric) acid (two parts of commercial muriatic acid to 14 parts of cold water should be strong enough). A heavily scaled shell may require a soaking period of several hours.

When using these solvents, carefully read and follow the instructions provided with the product. Perform work in a well ventilated area.

Drain completely and thoroughly flush shell with fresh water, repeating several times to be sure all traces of the lime removing agent are flushed away.

Descaler

The descaler is accessible through the hand hole opening. It is a coiled wire wound around a solid cylindrical core, and hangs by an open loop from the shell's horizontal stay rod, about 4" from the front of the shell. If the wire is eaten through, or if the core of the descaler is eaten away to half its original size, a new descaler should be installed. To install a new descaler, stretch its wire coil so that the descaler hangs with its core completely below the minimum water level in the generator, but hanging free. The descaler must not contact the bottom of the generator shell, or the electric heating elements or regenerator steam coils (if applicable).

Low Water Cutoff/Automatic Fill Control

The steam generator is equipped with level sensing probes and relays for controlling the flow of feed water to the boiler and to turn off the heat source when the level is too low.

The low level control is a simple series circuit with a transformer, secondary coil, relay coil, electrode, metal boiler and water. When water is below the low level cutoff electrode probe, the circuit is open and the coil is deactivated. When the water level is at or above the electrode probe, the circuit is closed by a path through the liquid from the probe to the metal boiler. The relay coil and the n.o. relay contacts 7 & 8 transfer positions, activating the heating contactor, or combination control, or solenoid valve.

The differential level control relay coil activates and the n.c. contacts 3 & 4 transfer positions once the water level reaches the top probe.

The relay coil will deactivate when the water level goes below the low level probe. This is achieved by holding the circuit closed with the use of an additional lower electrode probe through the n.o. contacts 7 & 8 on the relay. The relay activates when the water level reaches the top high level electrode probe, but does not deactivate until the level recedes below the low level electrode probe.

Loose electrical connections may prevent the heat from coming on or may cause the boiler to overflow. Accumulation of boiler scale on or near the sensing probes may cause them to retain water on the insulator surface. This may prevent the boiler from filling or cause dry firing. DRY FIRING WILL RESULT IN DAMAGE TO HEATING ELEMENTS OR TO THE BOILER SHELL.

With the probe wire removed, check the probes and contactors in the following manner:

1. With an ohmmeter, check the probe at wire connection and shell. There should be no resistance present when the boiler is empty. If resistance is present, remove and clean the probes. Also check for a cracked insulator, then reinstall probes and check. You should read continuity between the probes and shell only when the boiler shell is full of water.
2. Check low level and differential contactors. With a voltmeter, check across terminals 1 & 2. Meter should read 115 V. Across terminals 9 & 10, you should read 350 V. Using a jumper wire, jump terminals 9 & 10. Contactor should engage. If contactor does not engage, replace contactor.
3. Remove sensing probe. First remove the bolted cover over the sensor cluster. Then remove the wire from the probe and unscrew the probe with a wrench. Be careful to note the location of each probe and the number of the wire connected to it. Incorrectly connected wires will cause the controls to malfunction.
4. Clean probe thoroughly, removing ALL deposits from the insulator. Do not use an abrasive on the insulator; use a soft cloth.
5. Inspect through the probe socket for the presence of water. Water must drain from the probe housing. If in doubt, pour water into the housing and observe that it drains quickly. If the housing fails to drain, remove the housing or housing cover and clean the interior mechanically.

Water Level Gauge Assembly

Close the valve at the top and at the bottom of the gauge assembly. Unscrew the packing nuts at the top and bottom of the glass tube. Slide the glass tube up until the bottom of the tube is clear of the fitting. When reinstalling the tube, use new sealing washers. Do not overtighten the packing nuts; it could break the gauge glass. Check that both top and bottom valves are fully open.

Pressure Switches

WARNING: DISCONNECT ELECTRICAL POWER SUPPLY BEFORE REMOVING BOILER CONTROL BOX COVER.

There are two pressure switches located inside the boiler control box. One pressure switch is the cycling or primary control; the other is the high limit control. They are identical switches, differing only in their settings. Each one is identified by a label attached to the switch case. The labels show the proper setting for:

Cycling Switch: Off at 10 psi and on at 8 psi
High Limit Switch: Off at 15 psi and on at 6 psi

There are two square head slotted adjustment screws which project through the top of the switch case and a dial with pointers that indicate the approximate setting. The adjustment screw directly above the dial changes both the cut-out (off) and the cut-in (on) points. Set it first to give the proper OFF setting. Turning the screw clockwise increases the pressure. Then set the second adjustment screw to give the proper ON setting.

To check the wiring, remove the switch cover (held in place by one captive screw). If wiring is correct and an adjustment of the setting does not correct the problem, replace the control. DO NOT attempt to disassemble the switch or its operating mechanism.

High Limit Thermostat

Remove thermostat and inspect flat surface of thermostat for corrosion or rust. Replace if rusted.

Clean thermostat mounting and thermostat surfaces before remounting or replacing. A good metal-to-metal contact is essential for proper functioning of the thermostat. This service must be performed at least once a year.

On gas boilers, the high limit thermostat is located on the face of the boiler close to the sight glass on the right. For access, remove the approximately 2" x 2" metal cover placed over the thermostat.

On electric boilers, the high limit thermostat is located behind the contactor box cover. On electric boilers with two heating elements, the thermostat is connected to one of the heating element lugs. On electric boilers with four heating elements, the thermostat is located between the center pair of elements at the top of the elements.

Steam Supply Solenoid

The magnetic coil of a solenoid valve is removed from the valve by removing the snap catch at the center top. Unions are provided to allow easy removal of the valve bodies. The solenoid valves must be removed to disassemble them.

Remove the two screws and remove the inlet part of the body, the compression spring on the back of it and the plastic part now exposed.

Unscrew and remove the plunger tube. Remove the plunger (the valve blade is pinned to the lower end of the plunger). The plastic seat at the exhaust side of the valve blade may now be removed from the body. This is a direct acting valve.

The blade must be clean and the blade mating surfaces of the plastic seat members must be flat and undamaged. The plunger and plunger tube must be clean and the plunger must slide freely in the tube. The compression spring which fits in the hole in the top of the plunger must be clean and move freely.

Removing the Generator Assembly

Turn off the gas and electrical supplies and close the water inlet valve. Drain the generator. Remove the screws holding any control box which would obstruct removal of the boiler through the front of the generator base.

Disconnect the 1/4" diameter water inlet tubing. Disconnect the wire and conduit from the low water cut-off probes, high limit thermostat, and the automatic blow down valve (if so equipped). Uncouple the union on the steam outlet and blow down the lines.

Remove all the screws holding the flue and flue collector to the generator. Remove the anchor screws holding the generator to the frame. Slide the generator forward. The burner box, anchored only by the generator, must be prevented from sliding forward with the generator.

Fill Solenoid Valve

It is not necessary to remove the valve body from the supply line to disassemble it. Remove the retaining cap and remove coil assembly. Unscrew the stem from the valve body. All parts are now accessible for inspection and cleaning. Do not reuse damaged or worn parts. Pay careful attention to proper orientation and placement of parts during reassembly.

Water is Not Being Supplied to Boiler

Turn steamer ON. Check that water supply is available to the steamer. If after 20 minutes no water can be observed in the water level gauge sight glass, then check for a problem with the water solenoid valve or water level control float and/or probe.

The water level control probe may be covered by scalant, thereby falsely indicating sufficient water is present in the boiler. Detach, remove and thoroughly clean the water level control assembly to remove scalants and lime build-up. This condition indicates extremely poor water quality being supplied to the boiler. Water must be cleared up immediately with a proper water conditioner to avoid complete breakdown of the steamer.

Water may be draining through an open boiler blowdown solenoid valve as quickly as it is fed to the boiler. Loose wiring or a burned out coil may prevent the valve from closing. This valve contains a movable blade and when closed, the blade reacts as a guillotine which should be free to move fully down into the valve pocket (projection at bottom of valve) so that the pierced hole in the blade aligns perfectly with the body opening. If debris has accumulated in the bottom of the valve pocket, then the blade will not be able to move into the pocket completely.

If the valve coil needs to be replaced, remove valve from cooker body and remove retaining clip at top of solenoid. Grasp cover and housing (green) intact with coil inside and slide off from valve. Unscrew projecting tube from top of valve body and remove internal mechanism together with blade assembly. Next, unscrew both assembly bolts and split brass body of valve, removing loose internal parts. Flush and clean pocket thoroughly. Reassemble all parts in reverse order of disassembly. Energize valve with 120 volt power, and if valve fails to close, replace coil. Reconnect all plumbing.

Boiler Blowdown Solenoid Valve Does Not Drain

If your steamer has an automatic blowdown drain valve, when the blowdown button is depressed, the boiler blowdown valve opens. If your steamer has a manual blowdown drain valve, close it. The water contained in the boiler, being under pressure, should be blown through this valve and be noticeably visible exhausting out the steamer drain. If the blowdown operation appears to function sluggishly or not at all, considerable scalant may be lodged in the drain pipe and/or the valve. Disconnect the valve from the drain line and inspect both the valve and the drain pipe fixed to the boiler. If considerable scalant or lime build-up is apparent, then not only the valve, but also the boiler and water level control must be thoroughly cleaned. Refer to "Water Is Not Being Supplied To Boiler" for cleaning procedure of valve and "Removal of Scalants from Boiler."

Boiler Achieves Pressure Slower Than Normal

If the boiler requires more than 15 minutes to achieve normal operating pressure (6 to 7 psi), then assume that heavy build-up of scalant has completely coated the interior of the boiler. The insulating effect of the scalant hampers heat transfer.

Unbolt and remove the hand hole cover plate and gasket assembly. Examine interior of boiler, and if scalant and/or lime build-up is apparent, follow procedure for removal of scalants from boiler.

If considerable scalant is evident, then both the boiler blowdown solenoid valve and the water level control must also be examined.

GAS GENERATORS

The pilot thermocouple supplies power to the gas valve. A gas pressure regulating valve is an integral part of the gas control valve and is set for 3.5" Water Column for natural gas and 10" Water Column for propane gas. Limited adjustment is provided by a screw under the cap screw located at the top of the control body. Turn the screw clockwise to increase the gas pressure to the main burner.

The pilot burner flame is controlled by an adjustable valve (under cap screw behind the dial of the combination control valve). Turn clockwise to decrease pilot flame. Pilot flame should be a steady blue flame which envelopes the thermocouple tip. Pilot flame should be about 1" long. A pilot orifice fitting is located at the bottom of the pilot and is the hexagon fitting to which the gas supply tubing to the pilot is attached.

The main burners are lanced port steel burners (5 or 7 burners, depending on the unit) and have adjustable air shutters. Fixed orifice-type hoods are used to establish the gas flow to each burner. Set each burner air shutter opening just large enough to eliminate any yellow tip in the burner flame.

Pilot, Thermocouple or Main Burners

To remove the pilot assembly, disconnect thermocouple and pilot gas supply tubing from the combination control valve and remove the two screws holding the pilot to its bracket.

To remove main burners, lift burner and move it to the rear to clear the orifice hood, then lower front end of burner and bring it forward under the manifold pipe.

If pilot keeps going out, first check visually for proper pilot flame. Check to see that unusually strong floor drafts are not interfering with proper heating of the thermocouple by the pilot flame. If the pilot flame is not the proper height, adjust it. If adjustment does not result in a pilot flame of proper size, then gas is not flowing properly to the pilot. Check for a plugged pilot orifice, a kinked or plugged pilot gas supply tube, a problem in the combination control valve, or for low or high gas supply pressure. The pilot operates at gas supply pressure. The pressure regulator in the combination control valve regulates only the pressure of gas to the main burner.

If the pilot flame is correct and there are no drafts, then the problem is in the thermocouple or the combination control valve. Check the thermocouple with a millivoltmeter. If a meter is not available, replace thermocouple with a new one as a check. The connection of the tubing from the thermocouple tip to the control valve is an electrical connection and must be clean. Do not use any sealing compound on the threads. With a wrench, tighten the nut finger tight plus ¼ turn. DO NOT OVERTIGHTEN this nut. To check a thermocouple with a millivoltmeter, make a closed circuit check first (an adapter is required). Closed circuit reading should be 13 to 26 MV.

Blow pilot flame out. The reading when the protection valve closes (drop-out point) should be at least 5 MV below first reading. If first reading is correct, but drop-out point is not, problem is in the combination control valve. An open circuit check of the thermocouple should give a meter reading of 30 to 40 MV.

Gas Combination Control Valve Replacement

Disassembling this control is not recommended. If the control is not working, replace the entire control.

To remove the control, remove the two screws on the control box cover on which the generator push button switches are mounted. Disconnect wires and conduit running to the combination control valve. Disconnect thermocouple lead and pilot gas supply tube from control and uncouple pipe unions on each side of the control.

ELECTRIC GENERATORS

Magnetic Contactor

The contactor can be serviced by removing the cover of the contactor box.

A noisy contactor (hum or chatter) is generally due to enough dust or dirt on the armature pole faces or around the armature core that the magnet coil cannot pull the armature into a completely sealed position. This can usually be corrected by blowing or wiping the pole faces clean. To inspect contactor contact points, remove cover at top of contactor by removing two screws which hold it in place. Replace contactors if points are pitted or burned.

Electric Element

To determine whether all elements are heating properly, use an ampmeter with power ON to the elements. See wiring diagram for amperage ratings.

Always check that the supply voltage and the voltage rating of the element agree.

To replace an element, drain water from generator shell. Remove cover of contactor box, remove electric wires to that element's terminals, remove bolts through flange of element and pull element forward. When replacing an element, always use a new gasket. The flange and tube surfaces which contact the gasket must be clean.

If removed element shows a pronounced scale build-up on its heating tubes, the other elements should be removed and mechanically cleaned to remove the scale. This will prolong their life. DO NOT immerse elements in a chemical solution to descale.

Inoperative Control Circuit (Generator Control and Compartment Controls)

If the steamer is equipped with a step down transformer, check transformer for proper operation. If there is a separate 120 volt line for control circuit, check this line for power.

REGENERATING (STEAM COIL) GENERATORS

The steam coils are intended for use at a steam supply pressure of 15 psi maximum. A pressure regulating valve is available as optional equipment for steamers where the steam supply pressure exceeds 15 psi. Regulators of a different make and type may be supplied at different times and to meet special conditions; therefore, no specific service information for the regulator is included here. The regulator used will be of the adjustable type and should be set for a discharge pressure of 15 psi. A pressure gauge is provided to indicate the regulator discharge pressure. The regulator should be set when steam is flowing (steam solenoid valve is open). If steam is heavy with condensate, install a ball float trap in the steam line before the pressure regulating valve.

To remove a steam coil, disconnect union in steam supply line to the coils and in the condensate discharge line from the coils. Remove header that supplies steam to coils by disconnecting union at each coil. In same way, remove coil condensate collection header. Remove four bolts clamping each coil flange in place and pull coil forward. Use a new flange gasket when replacing coil. The faces that mate with gasket must be clean.

Turn steamer power switch ON, allowing steam generation and, consequently, pressure to rise to normal operating level and then turn power switch OFF for a final purging of boiler and steam supply lines.

Steamer is now ready for use.

REPLACEMENT PARTS LIST

REPLACEMENT PARTS ORDERING

The following information must accompany a replacements parts order or it cannot be filled.

- A. Model and style or serial number.
- B. Type of gas (natural or propane).
- C. Voltage and phase.
- D. Appliance finish, permafinish, stainless steel, etc. (if applicable to part to be replaced).

Use rating plate located inside base cabinet door to help you obtain the information listed above. This plate will provide all the necessary information required by the service agency.

Parts may be ordered only from your authorized parts and service depot. For assistance in locating your nearest authorized parts and service depot, refer to the enclosed directory.

ALL SERVICE PERSONNEL
WHEN SERVICING THIS EQUIPMENT, USE ONLY
CONTROLS ORIGINALLY SUPPLIED ON THIS EQUIPMENT BY
VULCAN-HART COMPANY.
DO NOT SUBSTITUTE.
SUBSTITUTION OF CONTROLS AS STATED ABOVE
WILL AUTOMATICALLY VOID THIS WARRANTY
AND THE CERTIFICATION ASSOCIATED WITH THIS EQUIPMENT.

COMPARTMENT DOOR

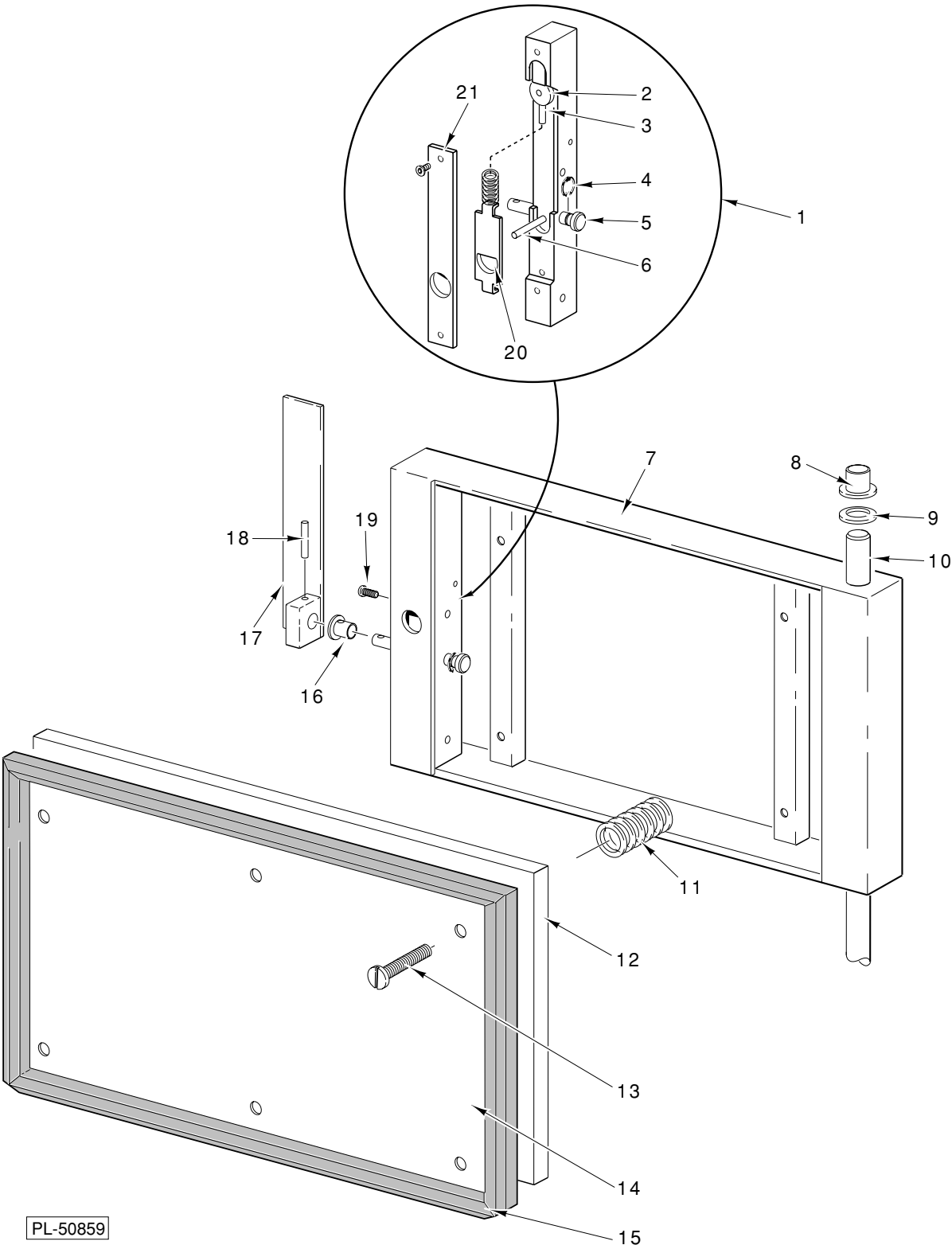

PL-50859

COMPARTMENT DOOR

ILLUS. PL-50859	PART NO.	NAME OF PART	AMT.
1	836976	Latch Plate Assy.	1
2	840489	Pin - Lock	1
3	840487	Pin - Spring Tension	1
4	840484	Retaining Ring	1
5	840481	Pin - Latch	1
6	840500	Pin - Spring Tension	1
7	840477	Panel - Door	1
8	840479	Bushing - Bronze	2
9	840493	Bushing - Bronze	1
10	840491	Rod - Hinge	1
11	836975	Spring - Compression	6
12	836974	Plate - Mounting	1
13	SC-120-81	Mach. Screw ¼-20 x 1½ Bndg. Hd.	AR
14	836973	Plate - Gasket	1
15	836919	Gasket - Door	1
16	840479	Bushing - Bronze	1
17	840485	Handle - Door	1
18	RP-2-13	Roll Pin	1
19	SC-115-42	Mach. Screw 10-32 x 1 Truss Hd.	2
20	840480	Locking Device	1
21	840483	Plate - Enclosure	1

CONTROL PANEL

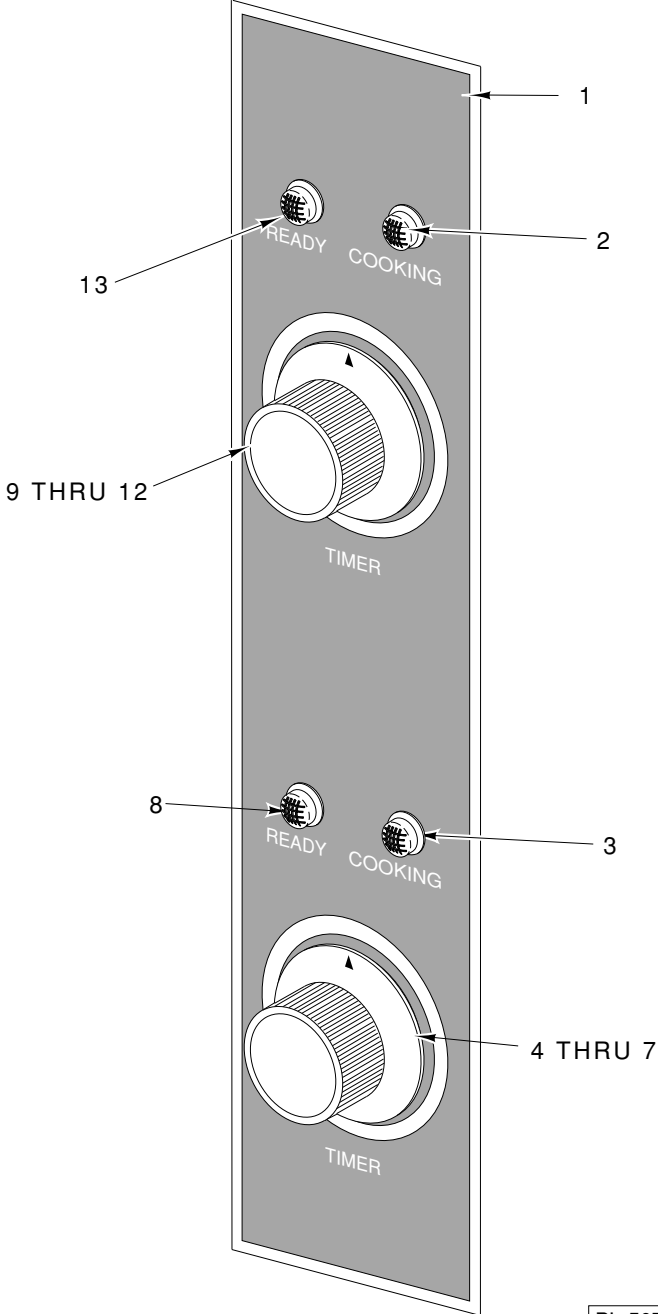

PL-50794

CONTROL PANEL

ILLUS. PL-50794	PART NO.	NAME OF PART	AMT.
1	840829	Panel - Control	1
2	843808	Light - Indicator (Red) (Cooking) (120 V.)	1
3	843808	Light - Indicator (Red) (Cooking) (120 V.)	1
4	843781-3	Knob - Timer (60 Hz.)	1
5	843781-4	Knob - Timer (50 Hz.)	1
6	843806	Timer (60 Min.)	1
7	843835	Buzzer	1
8	843807	Light - Indicator (Green) (Ready) (120 V.)	1
9	843781-3	Knob - Timer (60 Hz.)	1
10	843781-4	Knob - Timer (50 Hz.)	1
11	843806	Timer (60 Min.)	1
12	843835	Buzzer	1
13	843807	Light - Indicator (Green) (Ready) (120 V.)	1
	843811	Switch - Door (Not Shown)	1

ELECTRICAL COMPONENTS

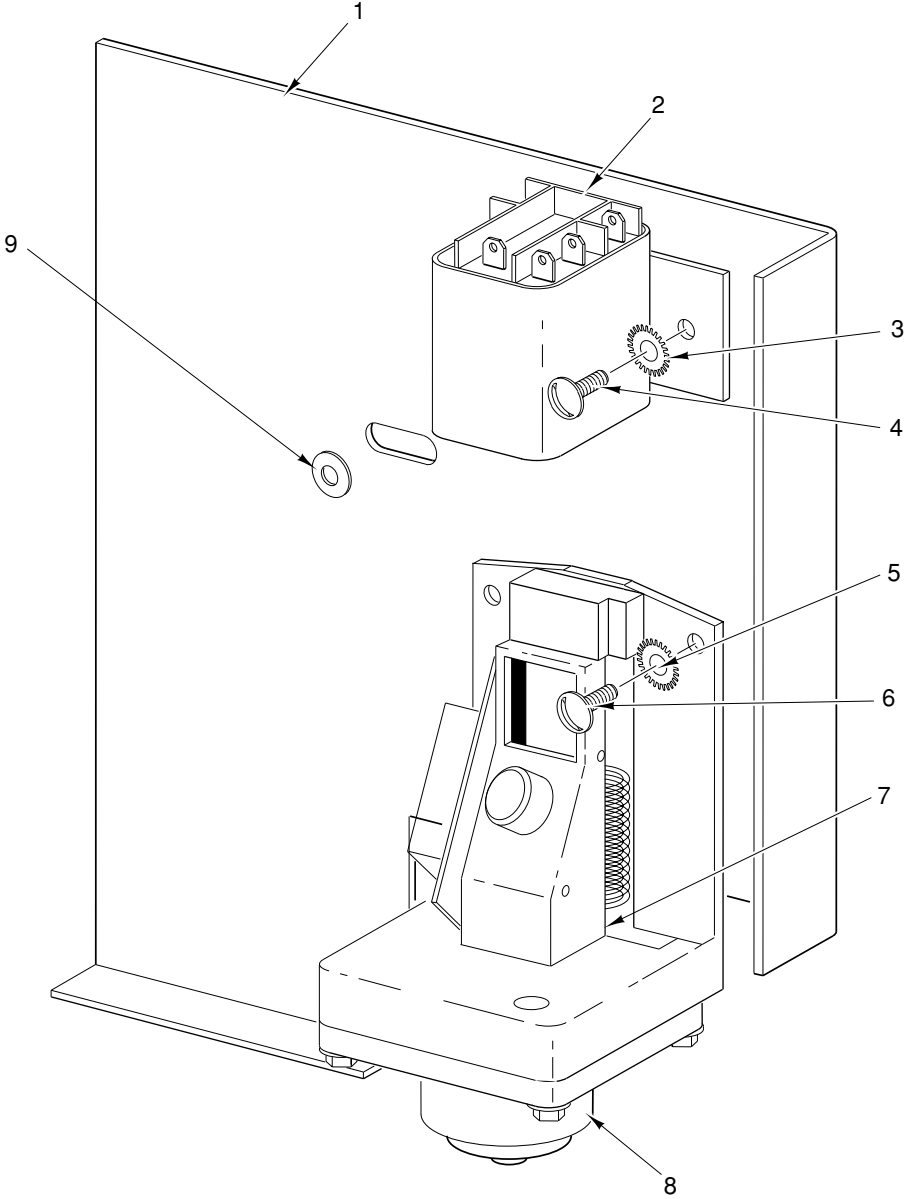

PL-50796

ELECTRICAL COMPONENTS

ILLUS. PL-50796	PART NO.	NAME OF PART	AMT.
1	843946	Panel - Component	1
2	843947	Relay	1
3	WL-7-6	Lockwasher	4
4	SD-35-88	Screw	4
5	WL-7-6	Lockwasher	2
6	SD-35-88	Screw	2
7	840832	Switch - Pressure	1
8	840833	Transducer	1
9	WS-29-18	Washer	1

PLUMBING

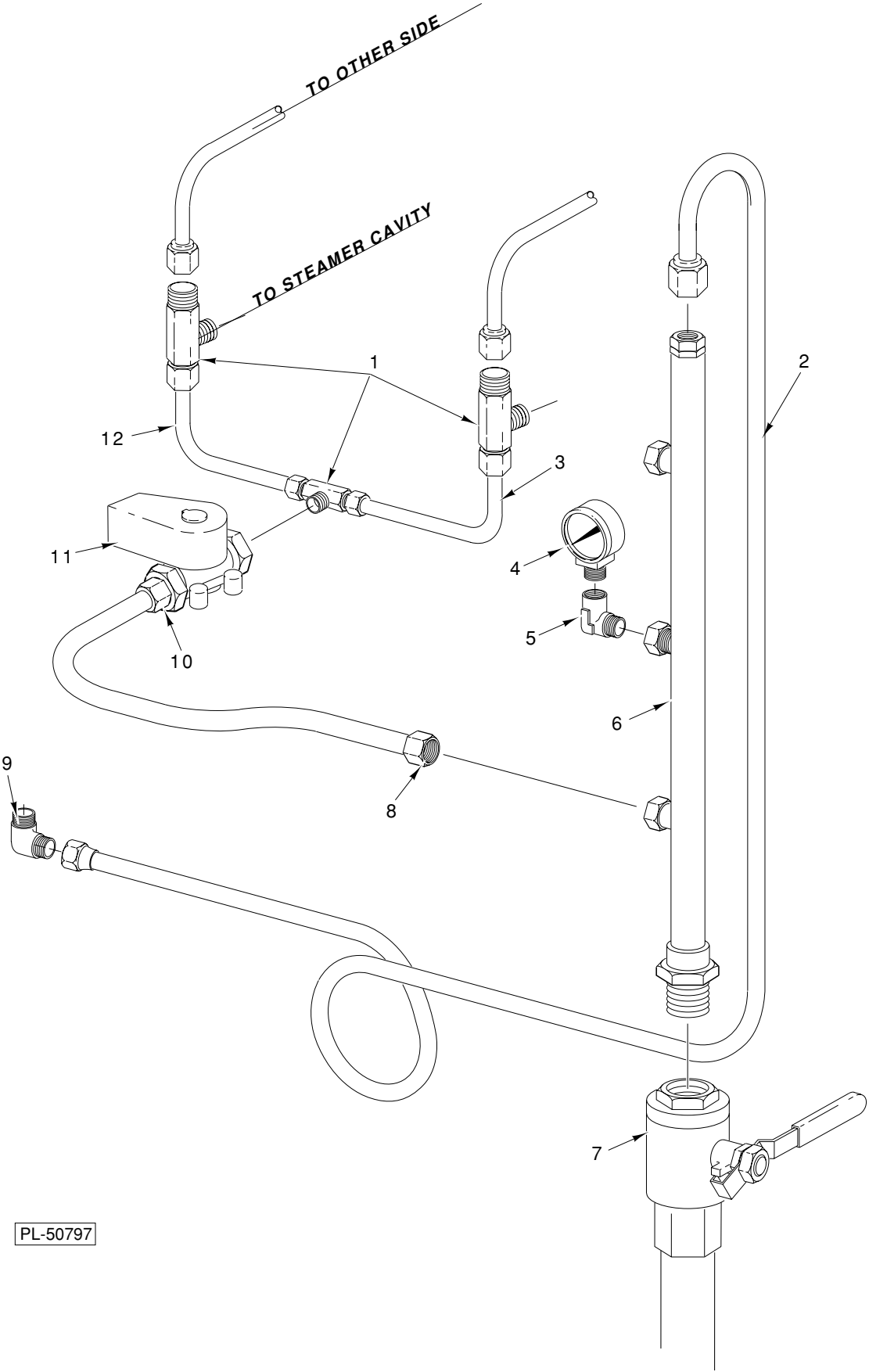

PL-50797

PLUMBING

ILLUS. PL-50797	PART NO.	NAME OF PART	AMT.
1	FP-81-34	Tee	4
2	843948	Tubing	1
3	843949	Tubing	1
4	843834	Gauge - Pressure.....	1
5	FP-15-5	Elbow	1
6	843950	Pipe	1
7	843837	Valve - Intake Shut-Off	1
8	FP-47-4	Fitting - Compression	1
9	FP-15-5	Elbow	1
10	FP-47-4	Fitting - Compression	1
11	843836	Valve - Solenoid	2
12	843951	Tubing	1

LEVEL CONTROL BOX (36" & 42" GAS GENERATORS)

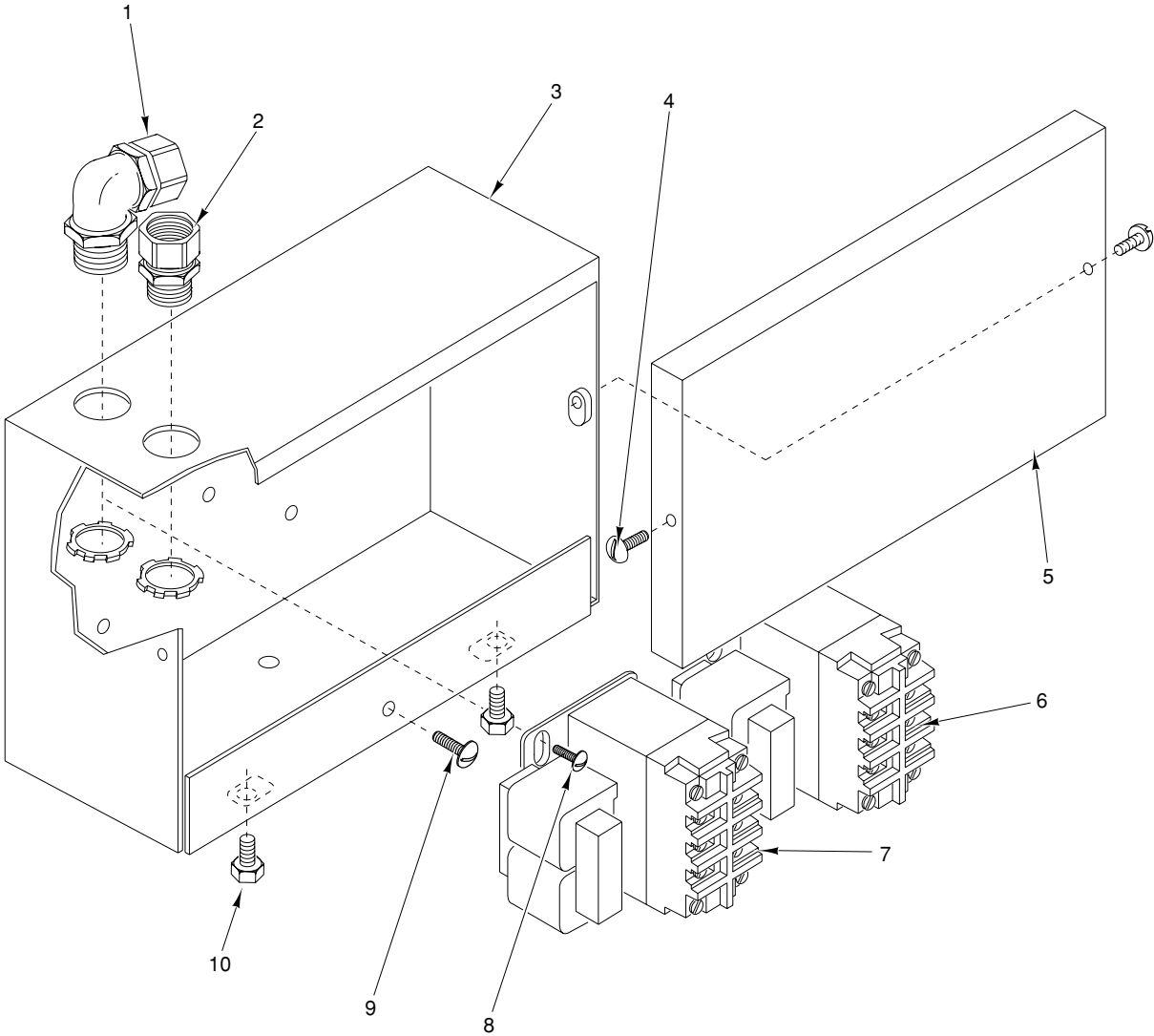

PL-50611

LEVEL CONTROL BOX (36" & 42" GAS GENERATORS)

ILLUS. PL-50611	PART NO.	NAME OF PART	AMT.
1	880397	Connector 3/8" x 90 Deg. Sealtite	AR
2	880675	Connector 3/8" Straight Sealtite	AR
3	817256	Box - Level Control	1
4	SC-53-5	Mach. Screw 10-24 x 3/8 Truss Hd., Slotted	2
5	817257	Cover - Level Control Box	1
6	817234-1	Control - Differential Level	1
7	817234-1	Control - Low Level	1
8	SC-66-2	Mach. Screw 6-32 x 3/8 Phil. Truss Hd.	6
9	SC-53-41	Mach. Screw 1/4-20 x 1/2 Truss Hd. SST	1
10	SC-41-50	Cap Screw 1/4-20 x 1/2 Hex Hd.	2

GENERATOR CONTROL BOX (36" & 42" GAS & ELECTRIC)

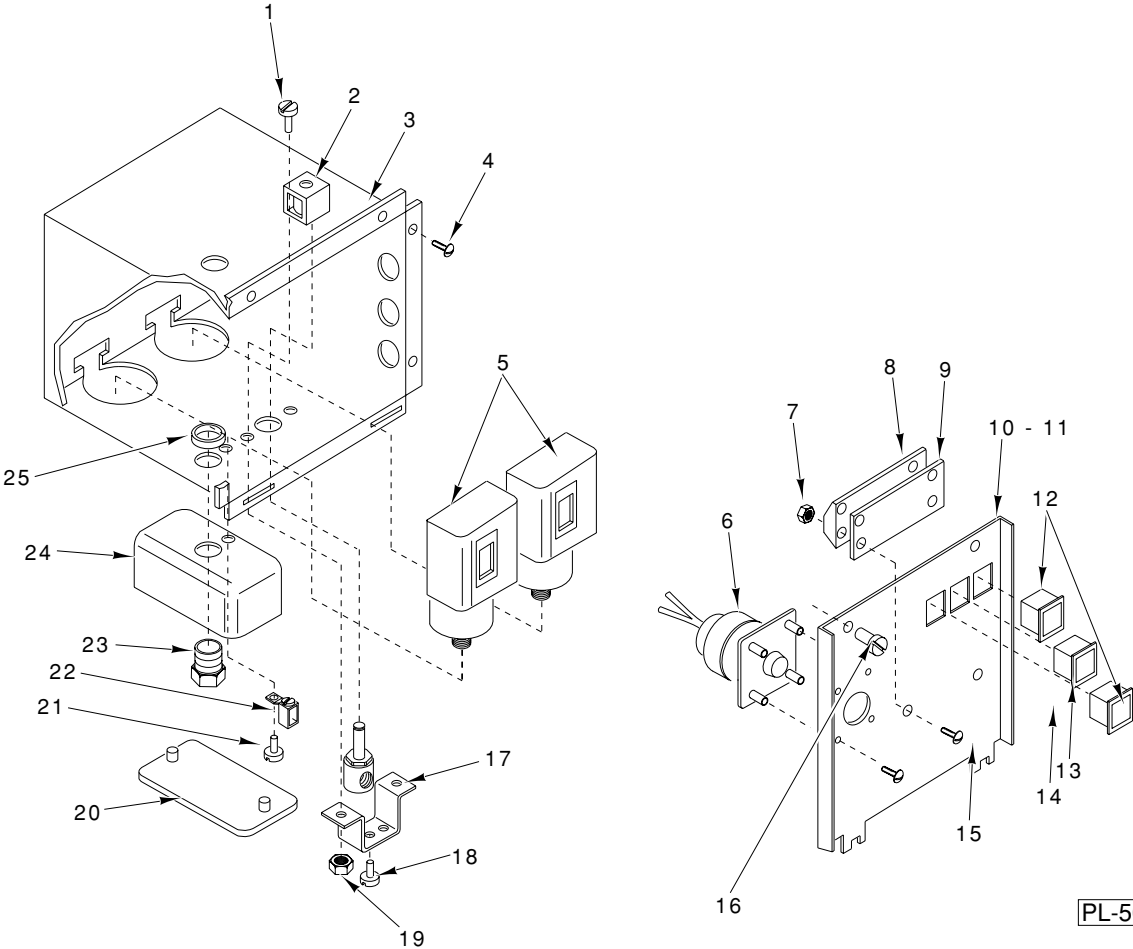

PL-50612

GENERATOR CONTROL BOX (36" & 42" GAS & ELECTRIC)

ILLUS. PL-50612	PART NO.	NAME OF PART	AMT.
1	SC-66-2	Mach. Screw 6-32 x 3/8 Phil. Truss Hd.	2
2	817222	Valve - Cold Water Condenser	1
3	881551-1	Box - Boiler Control	1
4	SC-53-2	Mach. Screw 10-24 x 1/2 Truss Hd. SST	4
5	833488	Switch - Pressure	2
6	817264	Timer	1
7	NS-11-18	Mach. Nut 10-24 Hex	2
8	881605	Strip - Terminal	1
9	881721	Strip - Terminal Marking	1
10	881552	Cover - Boiler Control Box (Manual Blowdown)	1
11	817227	Cover - Boiler Control Box (Auto Blowdown)	1
12	881579	Switch - Lighted (On/Off)	2
13	881673	Light - Indicator (Amber)	1
14	SC-119-53	Mach. Screw 8-32 x 3/4 Pan Hd.	2
15	SC-66-2	Mach. Screw 6-32 x 3/8 Phil. Truss Hd.	4
16	SC-53-2	Mach. Screw 10-24 x 1/2 Truss Hd. SST	1
17	817792	Bracket - Valve Retaining	2
18	RS-30-9	Rivet - Dome .125	2
19	NS-31-15	Stop Nut - Special 10-24 Hex (SST)	2
20	880396	Cover - Entrance Box (With Screws)	1
21	SC-53-5	Mach. Screw 10-24 x 3/8 Truss Hd., Slotted	1
22	FE-23-87	Lug - Grounding	1
23	FP-54-8	Pipe 1/2 x 1.125 (T.B.E.)	1
24	880395	Box - Entrance	1
25	907998	Locknut 1/2" Conduit	AR

GENERATOR CONTROL BOX (24" GAS)

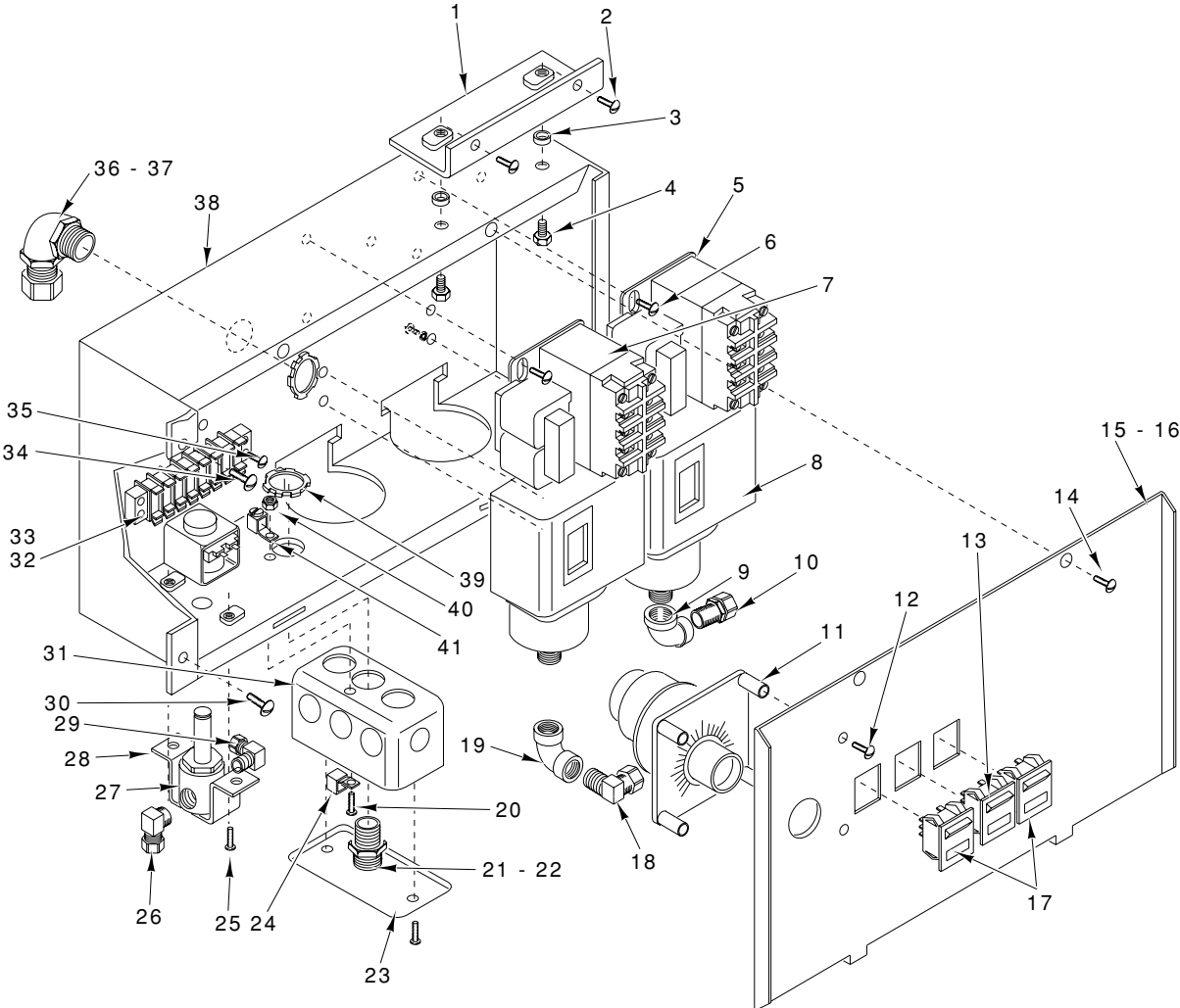

PL-50613

GENERATOR CONTROL BOX (24" GAS)

ILLUS. PL-50613	PART NO.	NAME OF PART	AMT.
1	817301-3	Bracket - Control Box Mtg.	1
2	SC-53-41	Mach. Screw 1/4-20 x 1/2 Truss Hd. SST	2
3	833211	Lockwasher	2
4	SC-41-50	Cap Screw 1/4-20 x 1/2 Hex Hd.	2
5	817234-1	Control - Differential Level	1
6	SC-66-2	Mach. Screw 6-32 x 3/8 Phil. Truss Hd.	6
7	817234-1	Control - Low Level	1
8	833488	Switch - Pressure (Includes Screws & Washers)	2
9	FP-15-5	Elbow 90 Deg. x 1/4 F.P.T.	1
10	FP-47-24	Fitting - Tube 1/4 x 1/4 Brass Elbow 90 Deg.	1
11	817264	Timer	1
12	SC-66-2	Mach. Screw 6-32 x 3/8 Phil. Truss Hd.	4
13	881673	Light - Indicator (Amber)	1
14	SC-93-3	Mach. Screw 8-32 x 3/8 Phil. Pan Hd. SST	2
15	817302-2	Cover - Boiler Control Box (Manual Blowdown)	1
16	817302-1	Cover - Boiler Control Box (Auto Blowdown)	1
17	881579	Switch - Lighted (On/Off)	2
18	FP-47-24	Fitting - Tube 1/4 x 1/4 Brass Elbow 90 Deg.	1
19	FP-15-5	Elbow 90 Deg. x 1/4 F.P.T.	1
20	SC-53-3	Mach. Screw 10-24 x 3/4 Truss Hd., Slotted	1
21	907998	Locknut 1/2" Conduit	1
22	FP-54-8	Pipe 1/2 x 1.125 (T.B.E.)	1
23	880396	Cover - Entrance Box (With Screws)	1
24	FE-23-87	Lug - Grounding	1
25	RS-30-9	Rivet - Dome .125	2
26	FP-47-24	Fitting - Tube 1/4 x 1/4 Brass Elbow 90 Deg.	1
27	817222	Valve - Cold Water Condenser	1
28	817792	Bracket - Valve Retaining	1
29	FP-47-24	Fitting - Tube 1/4 x 1/4 Brass Elbow 90 Deg.	1
30	SC-53-41	Mach. Screw 1/4-20 x 1/2 Truss Hd. SST	1
31	880395	Box - Entrance	1
32	881605	Strip - Terminal	1
33	881721	Strip - Terminal Marking	1
34	SC-53-41	Mach. Screw 1/4-20 x 1/2 Truss Hd. SST	1
35	SC-93-5	Mach. Screw 8-32 x 1/2 Pan Hd.	2
36	880397	Connector 3/8" x 90 Deg. Sealtite	AR
37	880675	Connector 3/8" Straight Sealtite	AR
38	817301	Box - Control Boiler	1
39	907998	Locknut 1/2" Conduit	1
40	NS-31-15	Stop Nut - Special 10-24 Hex (SST)	1
41	FE-23-87	Lug - Grounding	1

GENERATOR CONTROL BOX (24" ELECTRIC)

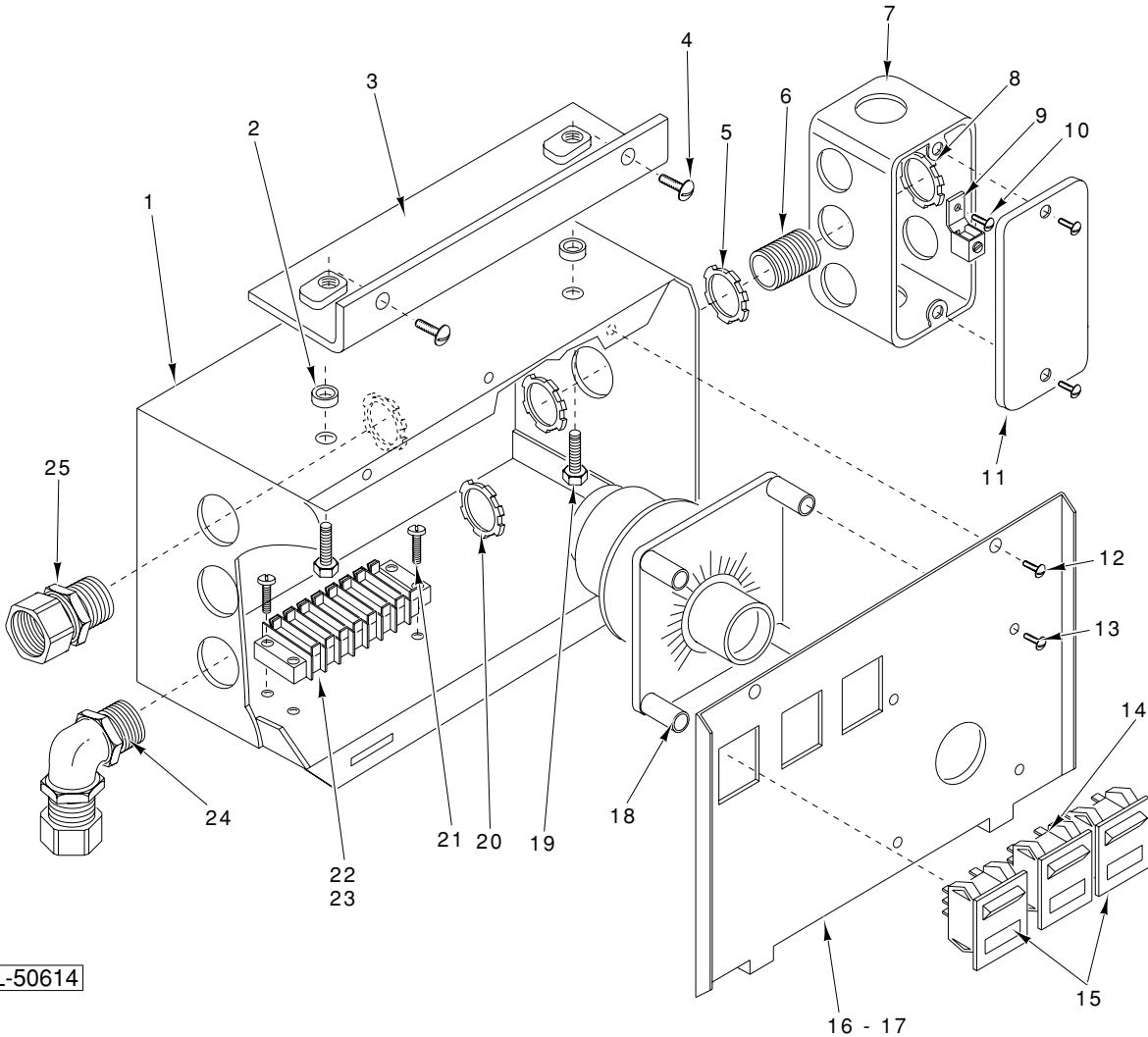

PL-50614

GENERATOR CONTROL BOX (24" ELECTRIC)

ILLUS. PL-50614	PART NO.	NAME OF PART	AMT.
1	817081	Box - Boiler Control	1
2	WS-3-45	Washer	AR
3	817081-3	Bracket - Control Box Mounting	1
4	SC-53-41	Mach. Screw 1/4-20 x 1/2 Truss Hd. SST	2
5	907998	Locknut 1/2" Conduit	AR
6	FP-54-8	Pipe 1/2 x 1.125 (T.B.E.)	1
7	880395	Box - Entrance	1
8	907998	Locknut 1/2" Conduit	AR
9	FE-23-87	Lug - Grounding	1
10	SC-53-5	Mach. Screw 10-24 x 3/8 Truss Hd., Slotted	1
11	880396	Cover - Box (Includes Screw)	1
12	SC-53-3	Mach. Screw 10-24 x 3/4 Truss Hd., Slotted	2
13	SC-66-2	Mach. Screw 6-32 x 3/8 Phil. Truss Hd.	4
14	881673	Light - Indicator (Amber)	1
15	881579	Switch - Lighted (On/Off)	2
16	817082-1	Cover - Boiler Control Box (Manual Blowdown)	1
17	817082-2	Cover - Boiler Control Box (Auto Blowdown)	1
18	817264	Timer	1
19	SC-41-50	Cap Screw 1/4-20 x 1/2 Hex Hd.	2
20	907998	Locknut 1/2" Conduit	AR
21	SC-93-5	Mach. Screw 8-32 x 1/2 Pan Hd.	2
22	881605	Strip - Terminal	1
23	881721	Strip - Terminal Marking	1
24	880397	Connector 3/8" x 90 Deg. Sealtite	AR
25	880675	Connector 3/8" Straight Sealtite	AR

GENERATOR CONTACTOR BOX & HEATER (LARGE SHELL)

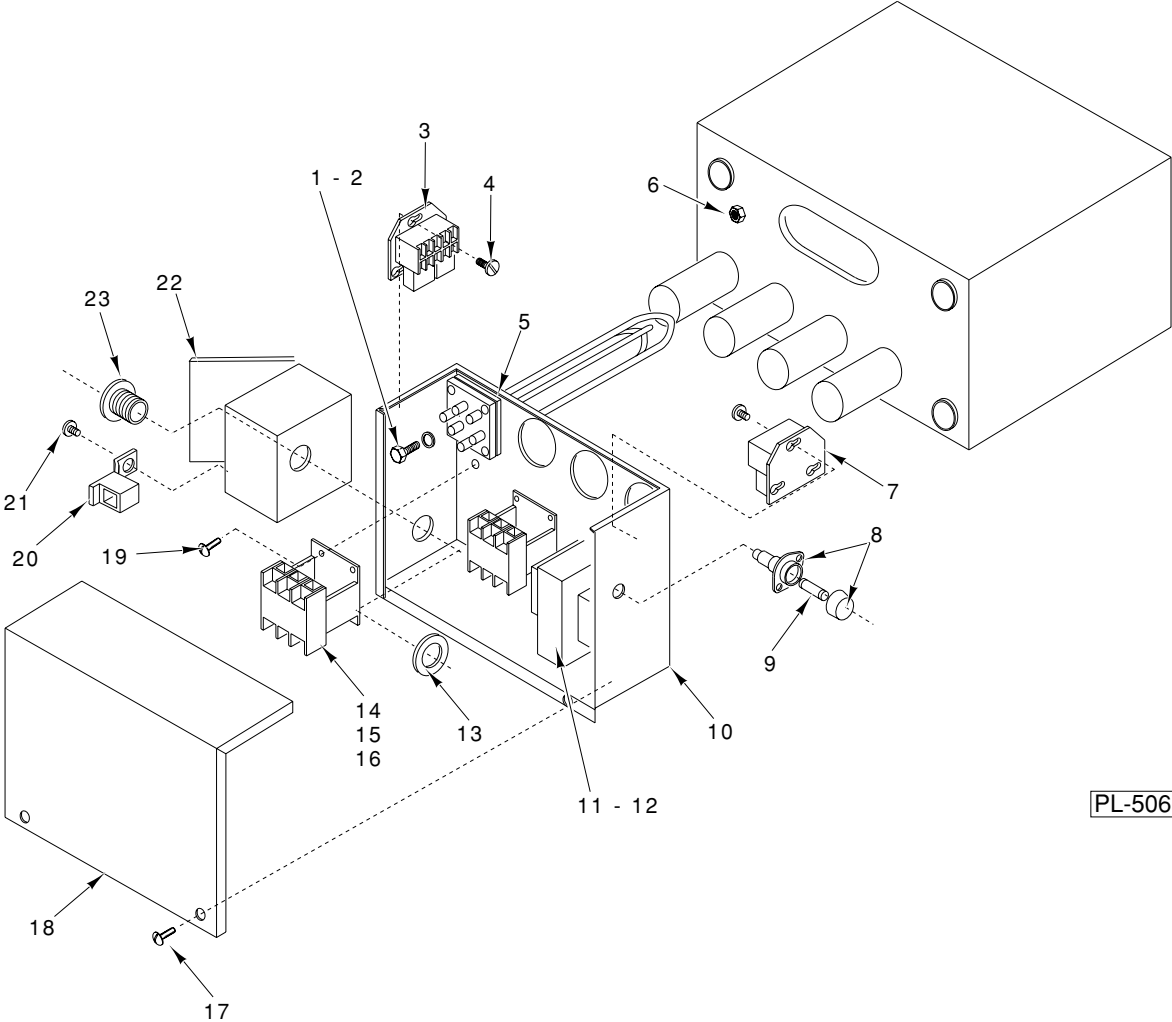

PL-50615

GENERATOR CONTACTOR BOX & HEATER (LARGE SHELL)

ILLUS. PL-50615	PART NO.	NAME OF PART	AMT.
1	SC-41-19	Cap Screw $\frac{5}{16}$ -18 x 2 Hex Hd.	16
2	WL-7-19	Lockwasher $\frac{5}{16}$ External Shakeproof	16
3	817234-1	Control - Differential Level	1
4	SC-66-2	Mach. Screw 6-32 x $\frac{3}{8}$ Phil. Truss Hd.	6
5	880410	Gasket - Boiler Heater	8
6	NS-15-11	Full Nut $\frac{5}{16}$ -18 Hex	16
7	817234-1	Control - Low Level	1
8	881236	Fuseholder (W/Transformer Only)	1
9	881237	Fuse - 10 AMP (W/Transformer Only)	1
10	881528	Box - Contactor	1
11	880314	Transformer (Optional Extra)	1
12	SC-53-41	Mach. Screw $\frac{1}{4}$ -20 x $\frac{1}{2}$ Truss Hd. SST	4
13	FE-14-25	Bushing - Elect. Plastic	2
14	881654	Contactor 40 AMP	1
15	881655	Contactor 50 AMP. (See Heat Circuits)	1
16	881656	Contactor 60 AMP.	2
17	SC-53-2	Mach. Screw 10-24 x $\frac{1}{2}$ Truss Hd. SST	2
18	881529	Cover - Contactor Box	1
19	SC-53-2	Mach. Screw 10-24 x $\frac{1}{2}$ Truss Hd. SST	1
20	FE-23-87	Lug - Grounding	1
21	SC-53-2	Mach. Screw 10-24 x $\frac{1}{2}$ Truss Hd. SST	AR
22	833512	Box - Junction Entrance	1
23	833513	Nipple - 1 $\frac{1}{4}$ Conduit	1

GENERATOR CONTACTOR BOX & HEATER (SMALL SHELL)

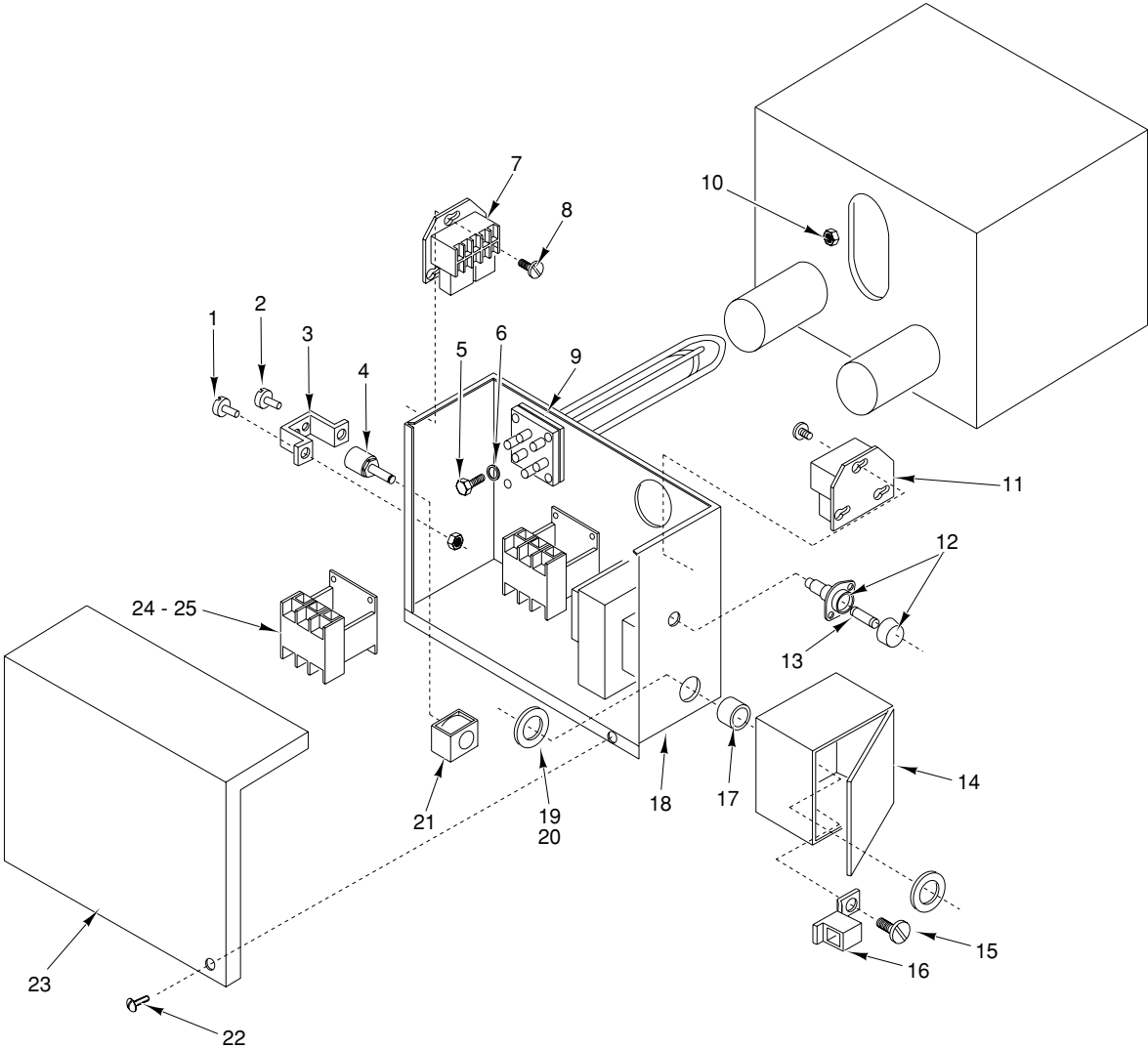

PL-50616

GENERATOR CONTACTOR BOX & HEATER (SMALL SHELL)

ILLUS. PL-50616	PART NO.	NAME OF PART	AMT.
1	SC-66-2	Mach. Screw 6-32 x 3/8 Phil. Truss Hd.	2
2	RS-30-9	Rivet - Dome .125	2
3	817792	Bracket - Valve Retaining	1
4	817222	Valve - Cold Water Condenser	1
5	SC-41-19	Cap Screw 5/16-18 x 2 Hex Hd.	8
6	WL-7-19	Lockwasher 5/16 External Shakeproof	8
7	817234-1	Control - Differential Level	1
8	SC-66-2	Mach. Screw 6-32 x 3/8 Phil. Truss Hd.	6
9	880410	Gasket - Boiler Heater	2
10	NS-15-11	Full Nut 5/16-18 Hex	8
11	817234-1	Control - Low Level	1
12	881236	Fuseholder (W/Transformer Only)	1
13	881237	Fuse 10 AMP (W/Transformer Only)	1
14	833512	Box - Junction Entrance	1
15	SC-53-2	Mach. Screw 10-24 x 1/2 Truss Hd. SST	1
16	911503-4	Lug - Ground	1
17	FP-83-59	Nipple - 1 1/4 x 1.500 Conduit	1
18	817043	Box Contactor	1
19	880314	Transformer (Optional Extra)	1
20	SC-53-2	Mach. Screw 10-24 x 1/2 Truss Hd. SST	4
21	833514	Lock Nut 1 1/4 Conduit	2
22	SC-53-2	Mach. Screw 10-24 x 1/2 Truss Hd. SST	2
23	817044	Cover - Contactor Box	1
24	817242	Contactor - 40 AMP	2
25	SC-53-2	Mach. Screw 10-24 x 1/2 Truss Hd. SST	2

GENERATOR

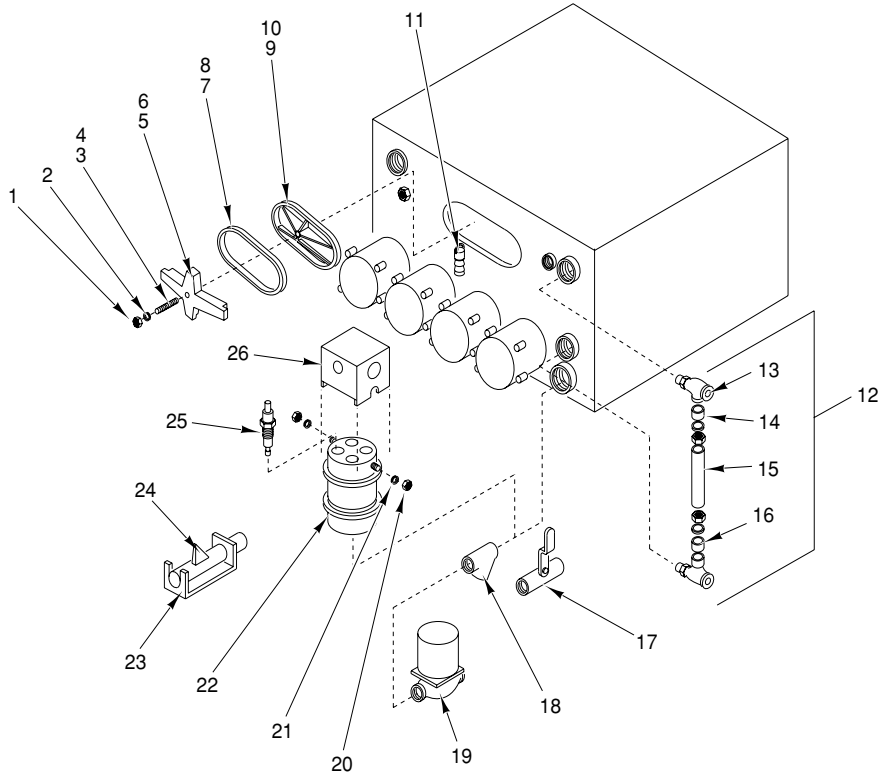

STEAM GENERATOR - LARGE & SMALL, REGENERATIVE & ELECTRIC

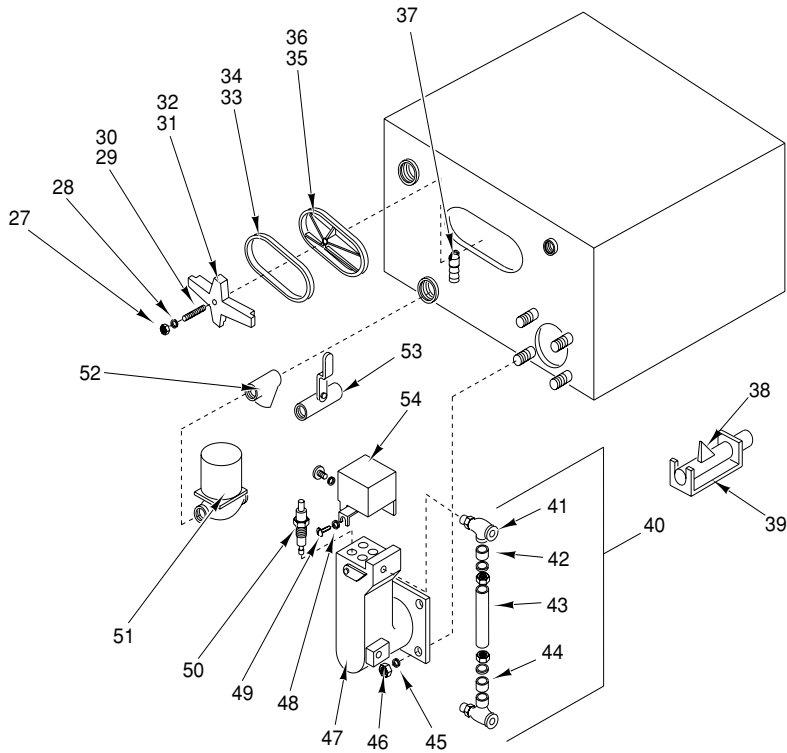

PL-50617

STEAM GENERATOR - LARGE & SMALL, GAS

GENERATOR

ILLUS. PL-50617	PART NO.	NAME OF PART	AMT.
1	NS-15-11	Full Nut 5/16-18 Hex	1
2	WS-5-32	Washer	1
3	880534	Stud - Hand Hole (Large)	1
4	817024	Stud - Hand Hole (Small)	1
5	880359	Spider - Hand Hole (Large)	1
6	817023	Retainer - Hand Hole (Small)	1
7	880023	Gasket - Hand Hole (Large)	1
8	817025	Gasket - Hand Hole (Small)	1
9	880358	Plate - Hand Hole (Large)	1
10	817022	Plate - Hand Hole (Small)	1
11	880044	Descaler	1
12	817098	Glass - Gage	1
13	817098-3	Fitting - Gage Glass Top	1
14	817098-5	Washer - Gage Glass Sealing	1
15	817098-14	Tube - Gage Glass Sealing	1
16	817098-5	Washer - Gage Glass Sealing	1
17	881162	Valve - Drain/Blowdown (With Handle)	1
18	909459	Strainer (Auto Blowdown Only)	1
19	881865	Valve - (Auto Blowdown) Solenoid	1
20	NS-11-18	Mach. Nut 10-24 Hex	2
21	WS-19-6	Washer	2
22	817506	Canister Assy. (Incls.items 20, 21 & 25 thru 29)	1
23	817303-1	Brake - Water Inlet Valve	1
24	841959	Valve - Water Inlet	1
25	817233	Probe - Water Level Control	4
26	817504	Cover - Canister Top	1
27	NS-15-11	Full Nut 5/16-18 Hex	1
28	WS-5-32	Washer	1
29	880534	Stud - Hand Hole (Large)	1
30	817024	Stud - Hand Hole (Small)	1
31	880359	Spider - Hand Hole (Large)	1
32	817023	Retainer - Hand Hole (Small)	1
33	880023	Gasket - Hand Hole (Large)	1
34	817025	Gasket - Hand Hole (Small)	1
35	880358	Plate - Hand Hole (Large)	1
36	817022	Plate - Hand Hole (Small)	1
37	880044	Descaler	2
38	841959	Valve - Water Inlet	1
39	817303-1	Brake - Water Inlet Valve	1
40	817098	Glass - Gage	1
41	817098-3	Fitting - Gage Glass Top	1
42	817098-5	Washer - Gage Glass Sealing	1
43	817098-14	Tube - Gage Glass Sealing	1
44	817098-5	Washer - Gage Glass Sealing	1
45	WL-4-27	lockwasher 3/4 Helical	4
46	NS-17-45	Jam Nut 3/4-10 Hex	4
47	817580-1	Housing - Integral Probe	1
48	WS-19-6	Washer	2
49	SC-53-5	Mach. Screw 10-24 x 3/8 Truss Hd, Slotted	2
50	817233	Probe - Water Level Control	4
51	881865	Valve - (Auto Blowdown) Solenoid	1
52	909459	Strainer (Auto Blowdown Only)	1
53	881162	Valve - Drain/Blowdown (With Handle)	1
54	817600	Cover - Water Level Probe	1

REGENERATING STEAM BOILER

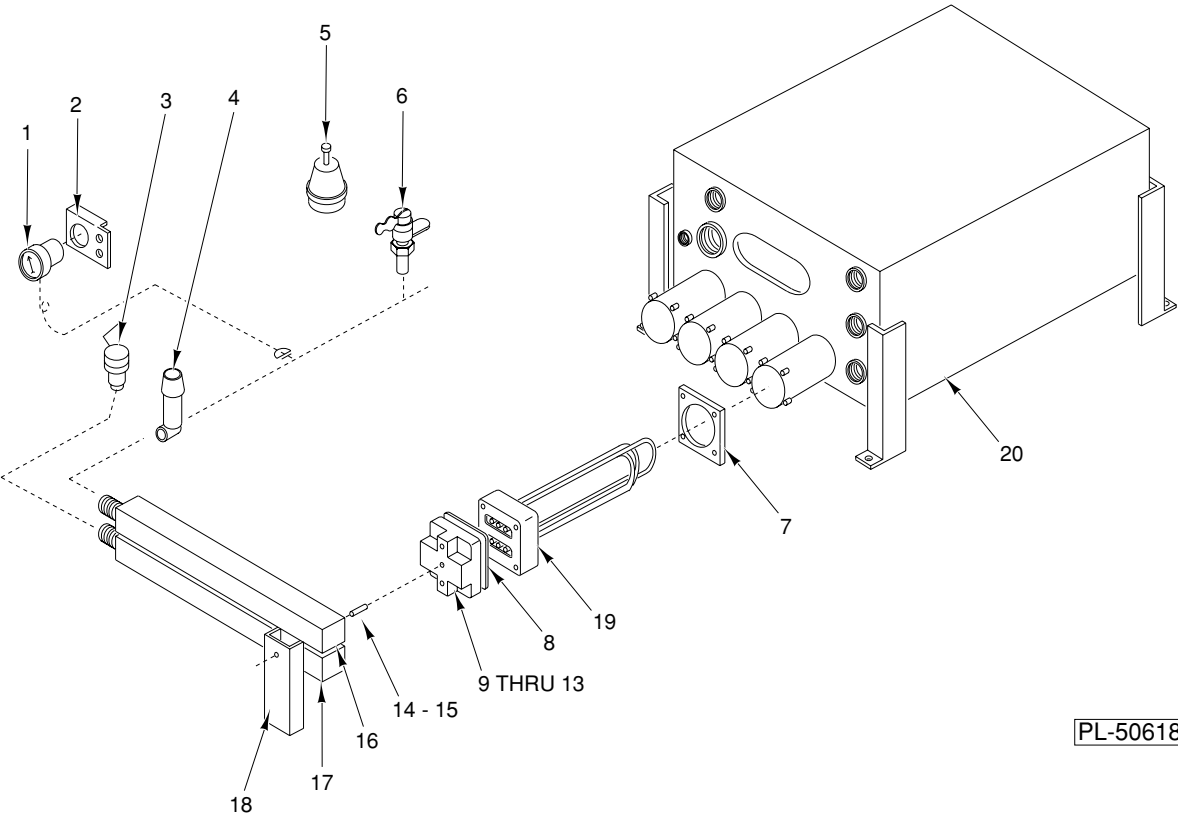

PL-50618

REGENERATING STEAM BOILER

ILLUS. PL-50618	PART NO.	NAME OF PART	AMT.
1	833152	Gauge - Pressure 0-31 P.S.I. 1/4 MPT	1
2	881057	Bracket - Pressure Gauge	1
3	881342	Trap - Steam Bucket	1
4	881865	Valve - (Auto Blowdown) Solenoid	1
5	880028	Valve - Pressure Regulating 3/4 N.P.T.	1
6	880413	Valve - Pressure Relief 3/4 N.P.T., 15 P.S.I.	1
7	880410	Gasket - Boiler Heater	8
8	881047	Gasket - Heater Cover	4
9	881043	Cover - Heater Plate	4
10	SC-119-34	Cap Screw 5/16-18 x 3/4 Hex Hd.	16
11	WS-5-43	Washer	16
12	881046	Stud - Heater Cover	4
13	NS-15-11	Full Nut 5/16-18 Hex	16
14	881049	Tube - Manifold Gasket	8
15	881048	Gasket - Manifold	8
16	881050-1	Inlet Manifold Assy.	1
17	881164-1	Exhaust Manifold Assy.	1
18	881054	Clamp - Manifold	4
19	881044-1	Steam Tube Assy.	4
20	843979-1	Boiler - Regenerative (Large)	1

GENERATOR COMBUSTION CHAMBER

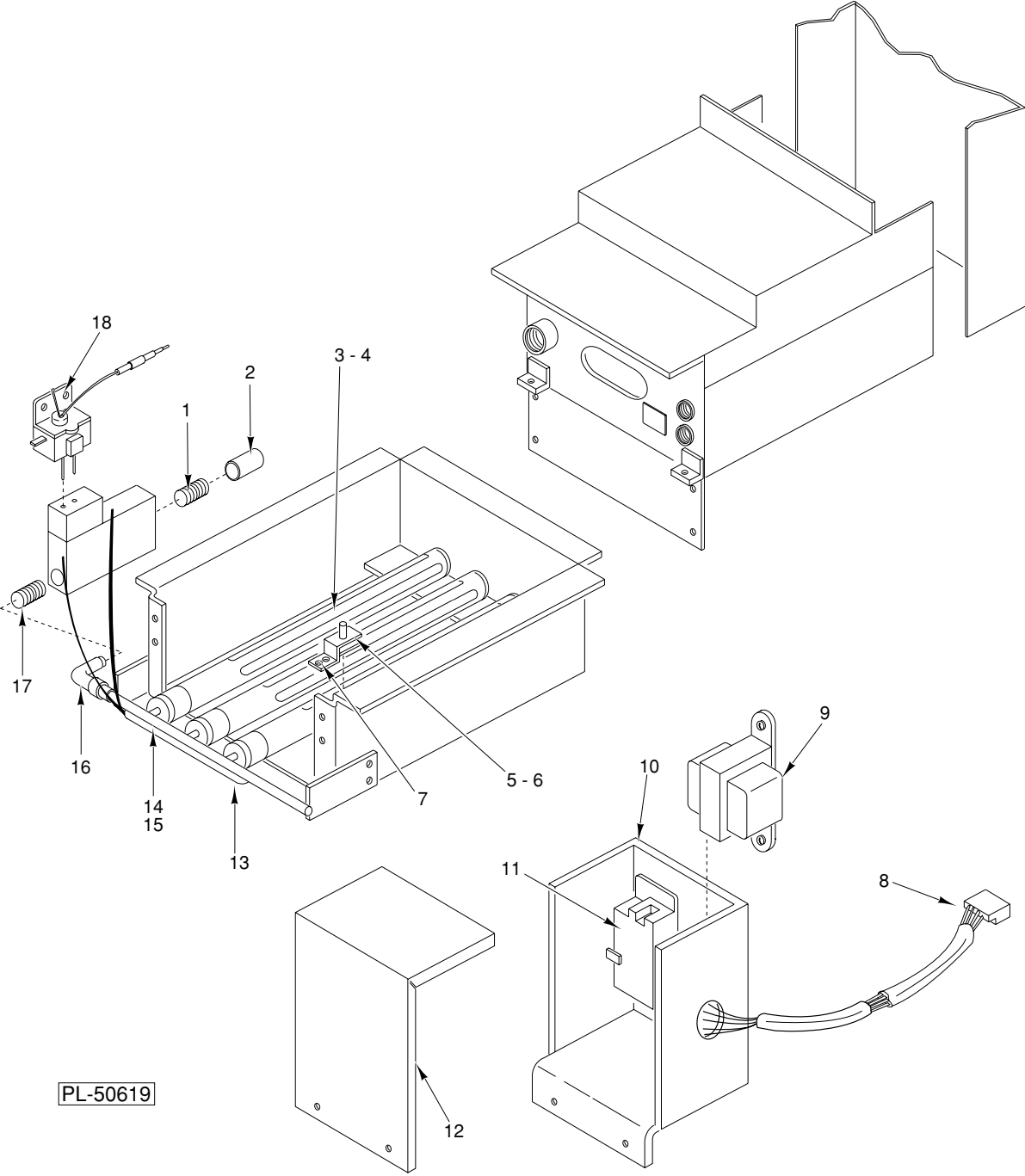

GENERATOR COMBUSTION CHAMBER

ILLUS. PL-50619	PART NO.	NAME OF PART	AMT.
1	FP-54-27	Nipple $\frac{3}{4}$ x $1\frac{3}{8}$ TBE (SST)	1
2	FP-23-24	Coupling - $\frac{3}{4}$ N.P.T. Pipe	1
3	817200	Sheet Metal Burner & Air Shutter Assy. (Nat.)	AR
4	817924	Sheet Metal Burner & Air Shutter Assy. (Prop.)	AR
5	817508	Thermocouple	1
6	817363-1	Pilot Body - Standard Ignition System	1
7	817916-1	Bracket - Mounting	1
8	821076	Harness - Wiring	1
9	821075	Transformer	1
10	817208	Box - Electronic Ignition	1
11	821078	Control - Ignition	1
12	817209	Cover - Ignition Box	1
13	500235	Tube - Pilot (28" Aluminum)	1
14	817167	Manifold - Gas (7 Burners)	1
15	817166	Manifold - Gas (5 Burners)	1
16	FP-84-44	Union - Pipe Elbow $\frac{3}{4}$ x 90 Deg.	1
17	FP-54-27	Nipple $\frac{3}{4}$ x $1\frac{3}{8}$ TBE (SST)	1

GENERATOR FRAME

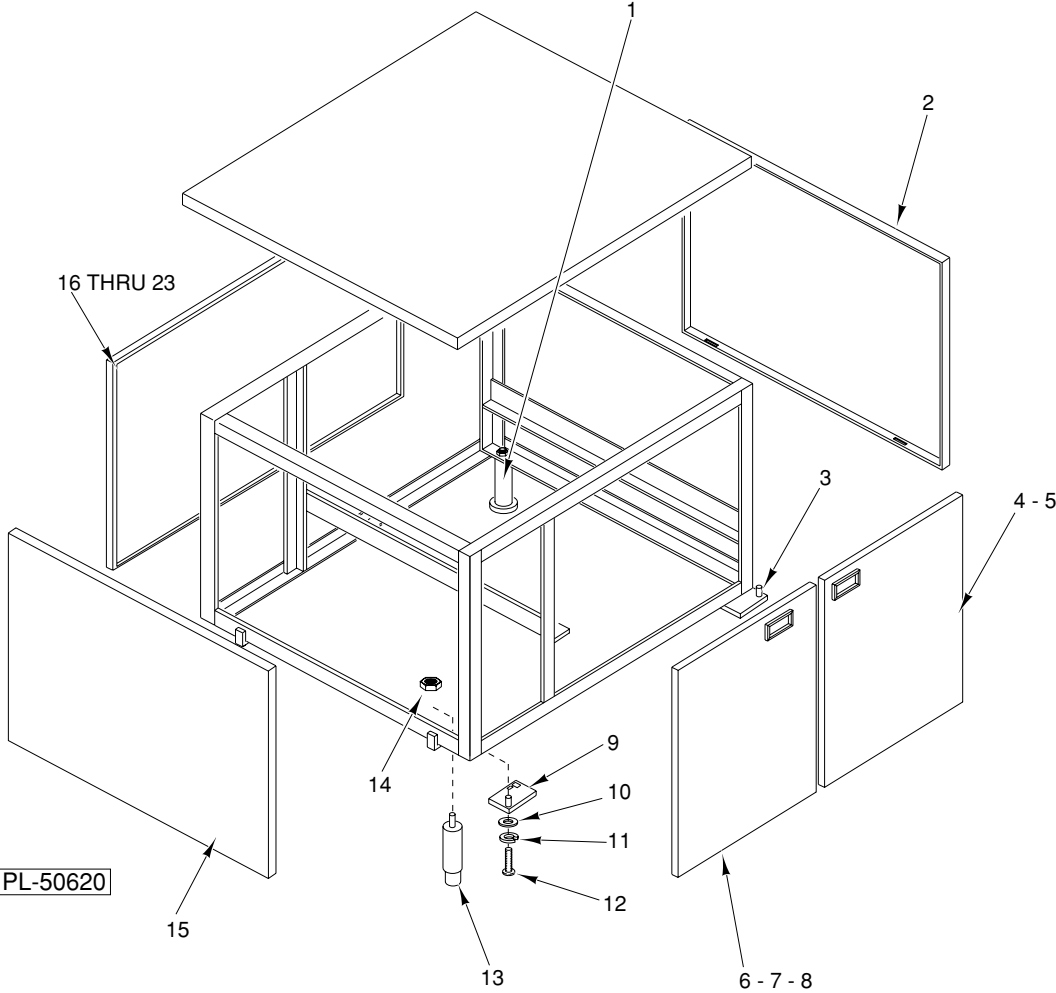

GENERATOR FRAME

ILLUS. PL-50620	PART NO.	NAME OF PART	AMT.
1	881526	Leg - W/6" Adjustable Flange Foot	2
2	881536	Panel - Side	1
3	881540-1	Hinge - Bottom Right	1
4	841985	Base Door Assy. (Right - 36")	1
5	843909	Base Door Assy. (Right - 42")	1
6	842469	Base Door Assy. (Left - 24")	1
7	842199	Base Door Assy. (Left - 36")	1
8	843908	Base Door Assy. (Left - 42")	1
9	881541-1	Hinge - Bottom Left	1
10	WS-17-6	Washer	4
11	WL-6-17	Lockwasher 1/4 Medium	4
12	SC-41-1	Cap Screw 1/4-20 x 3/4 Hex Hd	4
13	881525	Leg - W/6" Adjustable Foot	2
14	NS-13-40	Nut 5/8-11 Hex	4
15	881536	Panel - Side	1
16	881849-16	Back - Aluminized (24")	1
17	881849-13	Back - SST (24")	1
18	881537-11	Back - Aluminized (36")(170,000 & 200,000 & Elect.)	1
19	881537-12	Back - SST (36")(170,000 & 200,000 & Elect.)	1
20	881578	Back - Aluminized (36")(240,000)	1
21	881578-1	Back - SST (36")(240,000)	1
22	843905-1	Back - Aluminized (42")	1
23	843905-2	Back - SST (42")	1
	804556	Caster W/Out Brake	2
	804555	Caster W/Brake	2
	840414-1	Adapter - Leg to Caster	4
	817176	Frame Weldment Assy. (24")	1
	817316	Frame Weldment Assy. (36")	1
	843862	Frame Weldment Assy. (42")	1

PANELS

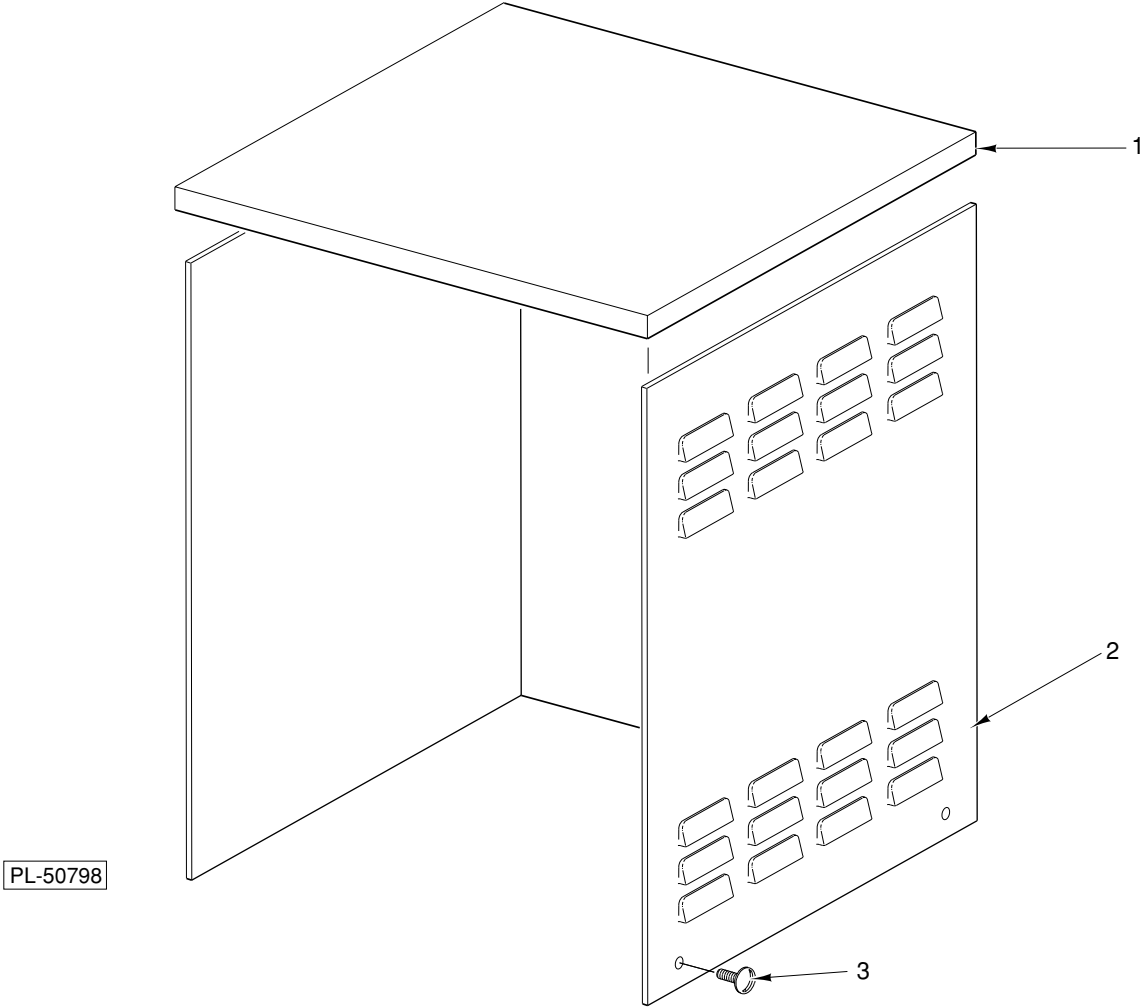

PANELS

ILLUS. PL-50798	PART NO.	NAME OF PART	AMT.
1	843831	Top - Housing	1
2	843830	Panel - Enclosure (R.H.)	1
3	SC-53-3	Mach. Screw 10-24 x 3/4 Truss Hd., Slotted	2

ELECTRONIC IGNITION (GAS STEAMERS)

ILLUS. PL-50991	PART NO.	NAME OF PART	AMT.
1	821089-1	Orifice - Natural Gas Pilot	1
2	821089-2	Orifice - Propane Pilot	1
3	821089-3	Pilot Body - Electronic Ignition System	1
4	817362-1	Valve - Gas (Propane)(Elect. Ignition)	1
5	836914-2	Valve - Gas (Propane)(Standard Ignition)	1
6	817362-2	Valve - Gas (Natural)(Elect. Ignition)(4" N.C. Pressure Regulator Setting)	1
7	836914-1	Valve - Gas (Natural)(Standard Ignition)	1

