



# CATALOG OF REPLACEMENT PARTS

## ELECTRIC COUNTER CONVECTION STEAMER VSX3, 4, & 5

### MODEL

ML-52396	VSX3	7.5 KW
ML-52397	VSX3	10.0 KW
ML-52398	VSX4	10.0 KW
ML-52399	VSX5	15.0 KW

### PRIOR MLS COVERED

ML-52802	VSX3	7.5 KW
ML-52803	VSX3	10.0 KW
ML-52815	VSX4	10.0 KW
ML-52817	VSX5	15.0 KW



For additional information on Vulcan-Hart or to locate an authorized parts and service provider in your area, visit our website at [www.vulcanhart.com](http://www.vulcanhart.com)

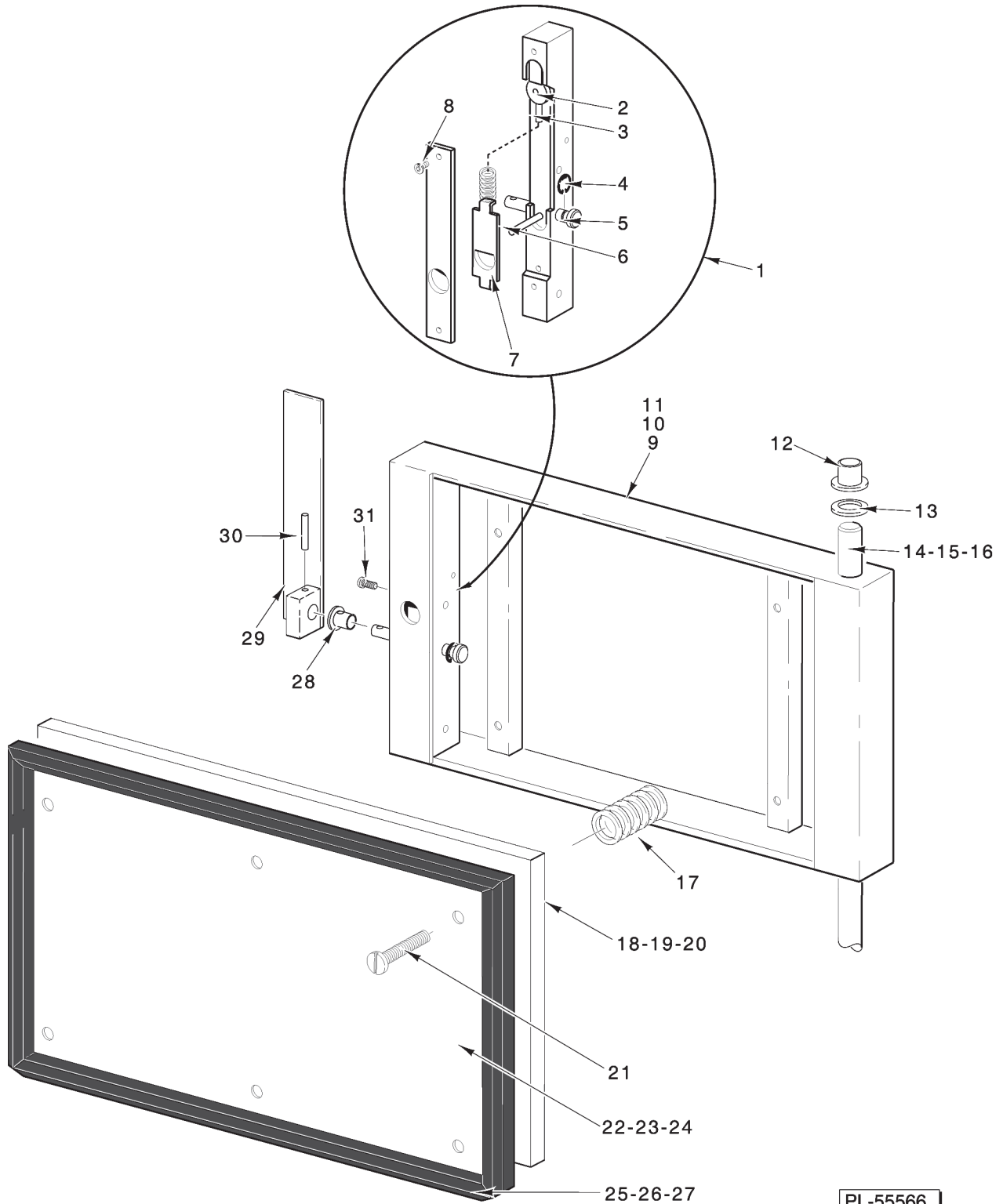

**DOOR  
(PREVIOUS CONSTRUCTION)**

**DOOR  
(PREVIOUS CONSTRUCTION)**

ILLUS. PL-55566	PART NO.	NAME OF PART	AMT.
1	00-836976	Door Latch Assy. (Incls. Items 2 thru 8) .....	1
2	00-840489	Pin – Lock .....	1
3	00-840487	Pin – Spring Tension .....	1
4	00-840484	Retaining Ring .....	1
5	00-840481	Pin – Latch .....	1
6	00-840500	Pin – Spring Tension .....	1
7	00-840480	Locking Device .....	1
8	00-840483	Plate – Enclosure .....	1
9	00-840477	Panel – Door (VSX-3) .....	1
10	00-843842	Panel – Door (VSX-4) .....	1
11	00-843843	Panel – Door (VSX-5) .....	1
12	00-840479	Bushing – Bronze .....	2
13	00-850447	Bushing – Bronze .....	1
14	00-840491	Rod – Hinge (VSX-3) .....	1
15	00-843850	Rod – Hinge (VSX-4) .....	1
16	00-843851	Rod – Hinge (VSX-5) .....	1
17	00-836975	Spring – Compression .....	6
18	00-836974	Plate – Mounting (VSX-3) .....	1
19	00-843844	Plate – Mounting (VSX-4) .....	1
20	00-843845	Plate – Mounting (VSX-5) .....	1
21	SC-120-81	Mach. Screw 1/4-20 x 1 1/2 Bndg. Hd. ....	AR
22	00-836973	Plate – Gasket (VSX-3) .....	1
23	00-843848	Plate – Gasket (VSX-4) .....	1
24	00-843849	Plate – Gasket (VSX-5) .....	1
25	00-836919	Gasket – Door (VSX-3) .....	1
26	00-843846	Gasket – Door (VSX-4) .....	1
27	00-843847	Gasket – Door (VSX-5) .....	1
28	00-840479	Bushing – Bronze .....	1
29	00-840485	Handle – Door .....	1
30	RP-002-13	Roll Pin .....	1
31	SC-115-42	Mach. Screw 10-32 x 1 Truss Hd. ....	2
	00-840492	Door Assy. (VSX-3) .....	1
	00-843853	Door Assy. (VSX-5) .....	1

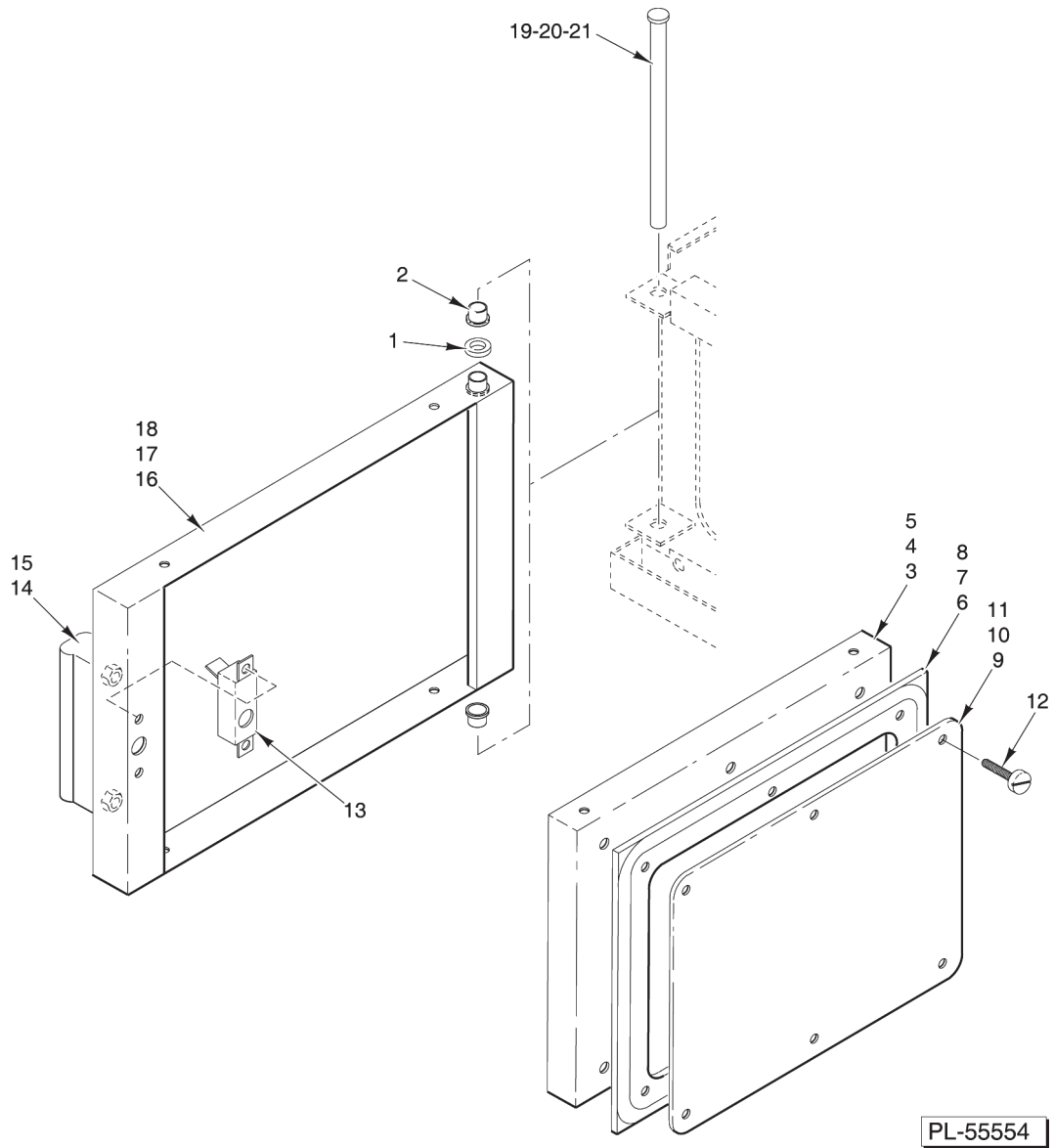

**DOOR  
(CURRENT CONSTRUCTION)**

**DOOR  
(CURRENT CONSTRUCTION)**

ILLUS. PL-55554	PART NO.	NAME OF PART	AMT.
1	00-850447	Spacer .....	2
2	00-840479	Bushing – Bronze .....	4
3	00-844195	Panel – Door (VSX-3) .....	1
4	00-845587	Panel – Door (VSX-4) .....	1
5	00-845588	Panel – Door (VSX-5) .....	1
6	00-844196	Gasket – Door (VSX-3, 14 <sup>5</sup> / <sub>8</sub> W X 11 <sup>7</sup> / <sub>16</sub> H) .....	1
7	00-844384	Gasket – Door (VSX-4, 14 <sup>5</sup> / <sub>8</sub> W X 14 <sup>11</sup> / <sub>16</sub> H) .....	1
8	00-844385	Gasket – Door (VSX-5, 14 <sup>5</sup> / <sub>8</sub> W X 17 <sup>15</sup> / <sub>16</sub> H) .....	1
9	00-851224	Plate – Gasket (VSX-3) .....	1
10	00-851417	Plate – Gasket (VSX-4) .....	1
11	00-851418	Plate – Gasket (VSX-5) .....	1
12	00-844453	Screw 10-32 x 1/2 Dimple Hd. ....	AR
13	00-844194	Latch Assy. ....	1
14	00-844193	Handle – Door .....	1
15	00-850447	Spacer – Door Handle .....	2
16	00-844192	Panel – Door (VSX-3) .....	1
17	00-845585	Panel – Door (VSX-4) .....	1
18	00-845586	Panel – Door (VSX-5) .....	1
19	00-850448	Rod – Hinge (VSX-3) .....	1
20	00-851411	Rod – Hinge (VSX-4) .....	1
21	00-851004	Rod – Hinge (VSX-5) .....	1
	00-844191	Door Assy. (VSX-3) (Incls. Items 2, 3, 6, 9, 13, 14, & 16) .....	1
	00-845583	Door Assy. (VSX-4) (Incls. Items 2, 4, 7, 10, 13, 14, & 17) .....	1
	00-845584	Door Assy. (VSX-5) (Incls. Items 2, 5, 8, 11, 13, 14, & 18) .....	1

**ELECTRIC COUNTER CONVECTION STEAMER VSX3, 4, & 5 REPLACEMENT PARTS**

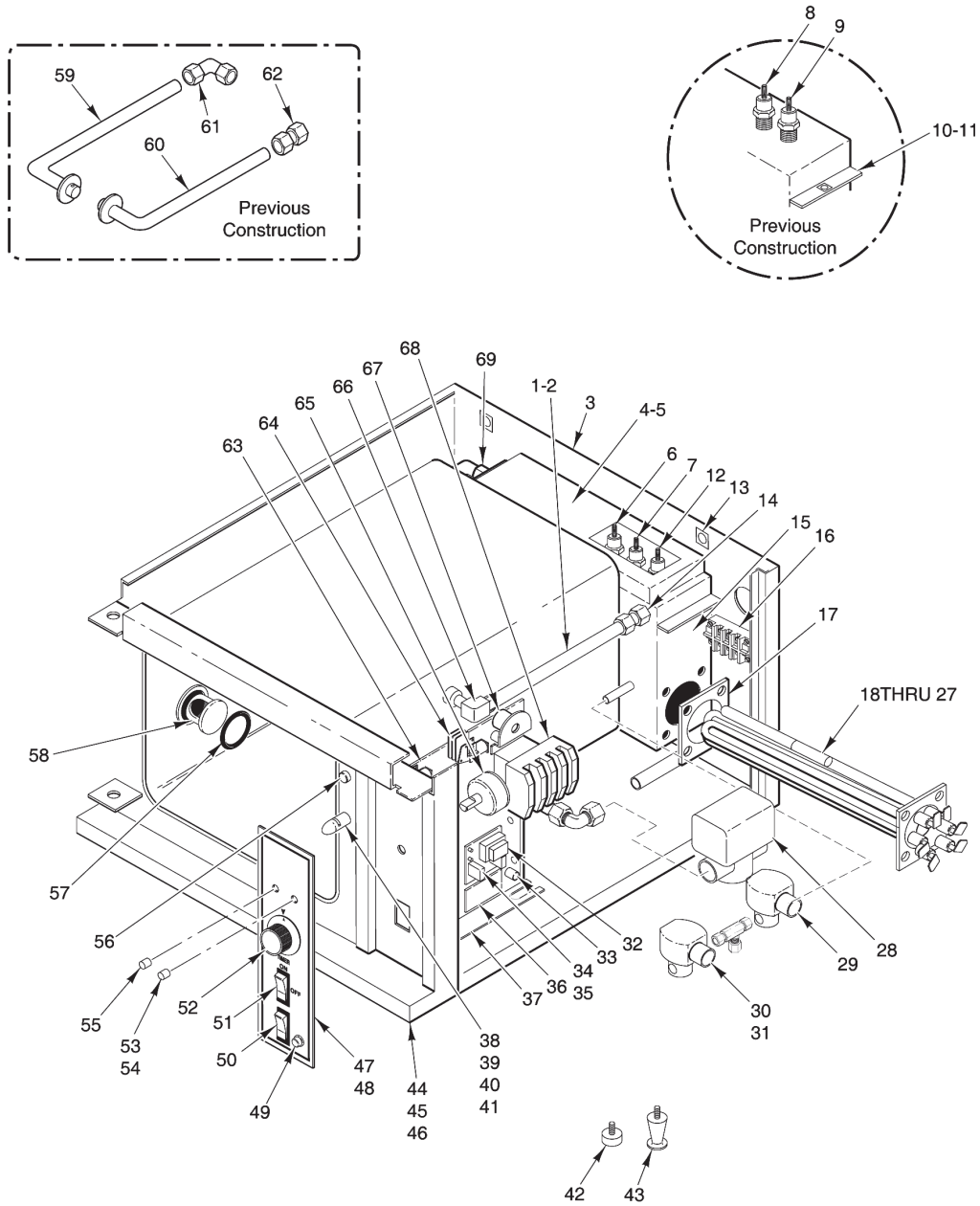

**PL-56402A**

**GENERAL ASSEMBLY**

ILLUS.	PART NO.	NAME OF PART	AMT.
1	00-853973	Steam Tube (Serial Numbers VSX3 AP1016845 Thru AP1024489, VSX4 AP1016964 Thru AP1024348, VSX5 AP1016969 Thru AP1024857) .....	1
2	00-853972	Steam Tube (Serial Numbers VSX3 AP1016845 Thru AP1024489, VSX4 AP1016964 Thru AP1024348, VSX5 AP1016969 Thru AP1024857) .....	1
3	00-843969	Panel – End .....	1
4	00-843809	Gasket – Tank .....	1
5	00-850484	Cover – Tank .....	1
6	00-850482	Probe – Low Level Cut-Off 5 .....	1
7	00-850483	Probe – Low Level 4 1/4 .....	1
8	00-844157	Probe – Low Level .....	1
9	00-844156	Probe – High Level .....	1
10	FP-028-11	Plug – Drain (Top Position) .....	1
11	00-843805	Plug – Drain (Bottom Position) .....	1

## GENERAL ASSEMBLY

ILLUS. PL-56402A	PART NO.	NAME OF PART	AMT.
12	00-844156	Probe – Short 3 <sup>11</sup> / <sub>16</sub> .....	1
13	00-854269	Nut – Cage .....	2
14	00-850011	Fitting – 1/2 Tube Union .....	2
15	00-854312	Tank – Steam Generator .....	1
16	00-840511	Terminal Block Assy. ....	1
17	00-836926	Gasket – Element .....	1
18	00-836927	Element Assy. (208 V., 7.5 kW) (VSX3) .....	1
19	00-836928	Element Assy. (240 V., 7.5 kW) (VSX3) .....	1
20	00-836929	Element Assy. (480 V., 7.5 kW) (VSX3) .....	1
21	00-843821	Element Assy. (208 V., 10.0 kW) (VSX3 or 4) .....	1
22	00-851408	Element Assy. (240 V., 10.0 kW) (ML-52397 & ML-52398) .....	1
23	00-843823	Element Assy. (480 V., 10.0 kW) (ML-52803 & ML-52815) .....	1
24	00-851409	Element Assy. (480 V., 10.0 kW) (ML-52397 & ML-52398) .....	1
25	00-843937	Element Assy. (208 V., 15.0 kW) (VSX5) .....	1
26	00-843938	Element Assy. (240 V., 15.0 kW) (VSX5) .....	1
27	00-843939	Element Assy. (480 V., 15.0 kW) (VSX5) .....	1
28	00-843804	Solenoid – Blowdown .....	1
29	00-853340	Solenoid – Fill .....	1
30	00-853340	Solenoid – Cooling (VSX3 & 4) .....	1
31	00-843944	Solenoid – Cooling (VSX5) .....	1
32	00-850429-00001	Thermostat – High Limit .....	1
33	00-881973	Thermostat – Pre Heat .....	1
34	00-843818	Control – Level (2 Probe, Mechanical) .....	1
35	00-850481	Control – Level (3 Probe, Solid State) .....	1
36	00-881978	Transformer (480 V. Unit) .....	1
37	00-851407	Plate – Component Mounting .....	1
38	00-840496	Striker .....	1
39	WS-030-38	Washer 1/2 (SST) .....	1
40	WL-006-36	Lockwasher 1/2 (SST) .....	1
41	NS-015-16	Nut 1/2-20 (SST) Hex .....	1
42	00-851761	Leg – Short Leveler .....	4
43	00-851944	Leg – 4 In. With Adjustable Foot (Set of 4) .....	1
44	00-843854	Trough – Perforated (ML-52815) .....	1
45	00-843855	Trough – Perforated (ML-52817) .....	1
46	00-840495	Trough – Perforated (ML-52803, ML-52396, ML-52397, ML-52398, & ML-52399) .....	1
47	00-355926	P.C. Board – Delime .....	1
48	00-844391	Step Down Transformer Delime .....	1
49	00-844388	Pilot Light, Delime Generator – Amber .....	1
50	00-855456	Switch, On/Off/Delime .....	1
51	00-836920	Switch – On/Off (No Delime) .....	1
52	00-843781-00003	Knob – Timer (ML-52397, ML-52398, ML-52399, & ML-52400) .....	1
53	00-843808	Light – Pilot (Red) (ML-52802, ML-52803, ML-52815, & ML-52817) .....	1
54	00-844367-00007	Light – Pilot (Red) (ML-52396, ML-52397, ML-52398, & ML-52399) .....	1
55	00-843807	Light – Pilot (Green) .....	1
56	00-842049	Switch – Door .....	1
57	00-844201	O-Ring .....	1
58	00-850041	Descaling Assy. ....	1
59	00-850004	Steam Tube LH (Serial Numbers VSX3 AP1016844 and Below, VSX4 AP1016963 and Below, VSX5 AP1016968 and Below.) .....	1
60	00-850001	Steam Tube RH (Serial Numbers VSX3 AP1016844 and Below, VSX4 AP1016963 and Below, VSX5 AP1016968 and Below.) .....	1
61	00-850012	Fitting 1/2 TBE x 1/2 TBE x 90 Deg. ....	1
62	00-850011	Fitting 1/2 TBE Union .....	1
63	00-843812	Relay – Single .....	1
64	00-843813	Relay – Double .....	1
65	00-411690-00002	Timer .....	1
66	00-853927	Fitting 1/2 TBE x 1/4 MPT 90 Deg. ....	2
67	00-844330	Buzzer .....	2
68	00-881975	Contactactor (3 Pole) .....	2
69	00-850012	Fitting 1/2 TBE x 1/2 TBE x 90 Deg. ....	1
	00-840499	Rack – Pan (VSX3) .....	1
	00-843859	Rack – Pan (VSX4) .....	1
	00-843860	Rack – Pan (VSX5) .....	1
	00-840494	Screen – Drain Comp. ....	1
	00-844160	Strainer – Water .....	1
	00-854471	Pressure Switch .....	1
	00-853270	Contactactor ( 4 Pole) .....	1

**GENERAL ASSEMBLY**

<b>ILLUS.</b>	<b>PART</b>	<b>NAME OF PART</b>	<b>AMT.</b>
PL-56402A	NO.		
	00-853974	2-amp Fuse .....	1
	00-851823	1-amp Fuse .....	1
	00-881970	Continuous Steam Switch .....	1
	00-851332	Rubber Boot for Steam Switch .....	1
	00-851759	Rack Hanger for Side Racks .....	1
	00-844401	Compression Fitting for Preheat Thermostat .....	1

**RECOMMENDED SPARE PARTS LIST**

**VSX3, VSX4 and VSX5 ELECTRIC UNITS  
STARTING WITH AP IN SERIAL NUMBER**

<b>PART NO.</b>	<b>NAME OF PART</b>	<b>AMT.</b>
00-836920	Switch, Power (ON/OFF No Delime) .....	2
00-855456	Switch, Power (ON/OFF Delime) .....	2
00-842029	Door Switch .....	2
00-843813	Relay 240V (Double) .....	2
00-843809	Tank Gasket .....	2
00-843818	Level Control (Built Before 8-01) .....	2
00-843812	Relay 110V (Single) .....	2
00-853340	Cooling Solenoid VSX3, VSX4 .....	2
00-836926	Element Gasket.....	2
00-881973	Thermostat .....	2
00-850429-00001	Safety Thermostat .....	2
00-836927	Element 208V 7.5 kW VSX3 .....	2
00-843821	Element 208V 10 kW VSX3, VSX4 .....	2
00-843937	Element 208V 15 kW VSX5 .....	2
00-836928	Element 240V 7.5 kW VSX3 .....	2
00-851408	Element 240V 10 kW VSX3, VSX4 .....	2
00-843938	Element 240V 15 kW VSX5 .....	2
00-881975	Contactor, 30-amp 3 Pole .....	2
00-853270	Contactor, 4 Pole .....	2
00-843804	Blowdown Solenoid.....	1
00-843944	Cooling Solenoid VSX5 .....	2
00-850481	Level Control (Built After 8-01) .....	2
00-844391	Delime Transformer .....	2
00-355926	Delime P.C. Board.....	2
00-854471	Switch, Pressure, 5 PSI .....	2
00-851823	Fuse, 1-amp .....	2
00-853974	Fuse, 2-amp .....	2
00-850025	Fuse, 3-amp .....	2

