

# Operator's Manual



## Lettuce King<sup>®</sup> I 400N, 401N, 402NC, 403N Lettuce King<sup>®</sup> IV 4400N



Thank you for purchasing this Vollrath Food Processing Equipment. Before operating the equipment, read and familiarize yourself with the following operating and safety instructions. **SAVE THESE INSTRUCTIONS FOR FUTURE REFERENCE.** Save the original box and packaging. Use this packaging to ship the equipment if repairs are needed.

## SAFETY PRECAUTIONS

To ensure safe operation, read the following statements and understand their meaning. This manual contains safety precautions which are explained below. Please read carefully.

### WARNING

Warning is used to indicate the presence of a hazard that can cause severe personal injury, death, or substantial property damage if the warning is ignored.

### CAUTION

Caution is used to indicate the presence of a hazard that will or can cause minor personal injury or property damage if the caution is ignored.

### NOTE

Note is used to notify people of installation, operation, or maintenance information that is important but not hazard-related.

### For Your Safety!

These precautions should be followed at all times. Failure to follow these precautions could result in injury to yourself and others or damage the equipment.

To reduce risk of injury or damage to the equipment:

- Check equipment before each use to insure the equipment is clean.
- Check for broken, nicked or dull blades and if found, replace the blade assembly.
- Check to insure that the pusher head sits down completely on the rubber bumpers.
- If necessary, lubricate guide rods using a light coating of mineral oil, Petro Gel, or food grade lubricant. **DO NOT USE COOKING OIL AS IT WILL BECOME STICKY AND MAY PERMANENTLY DAMAGE THE PUSHER HEAD BEARINGS**

## FUNCTION AND PURPOSE

Intended for cutting, dicing and wedging vegetables and fruits.

## FEATURES AND CONTROLS

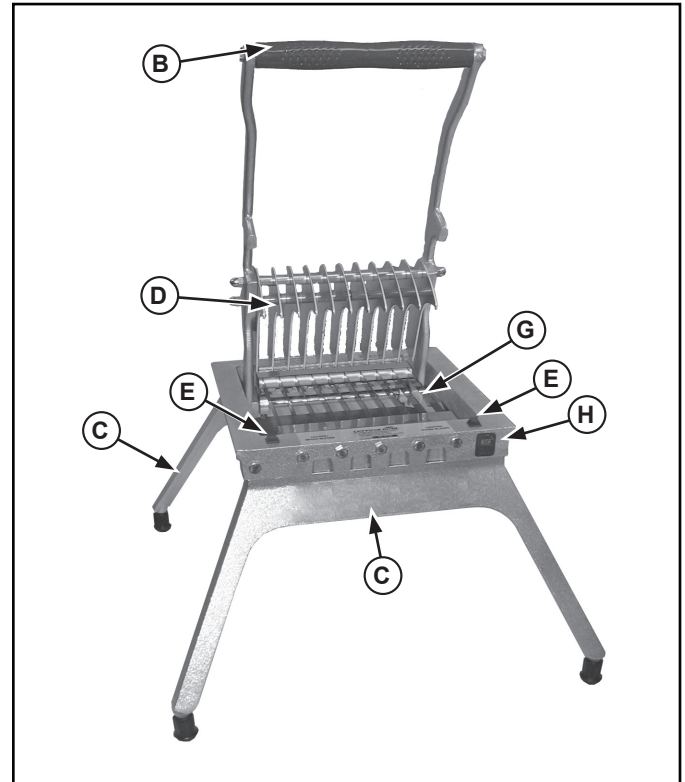

Figure 1. Features and Controls Lettuce King I.

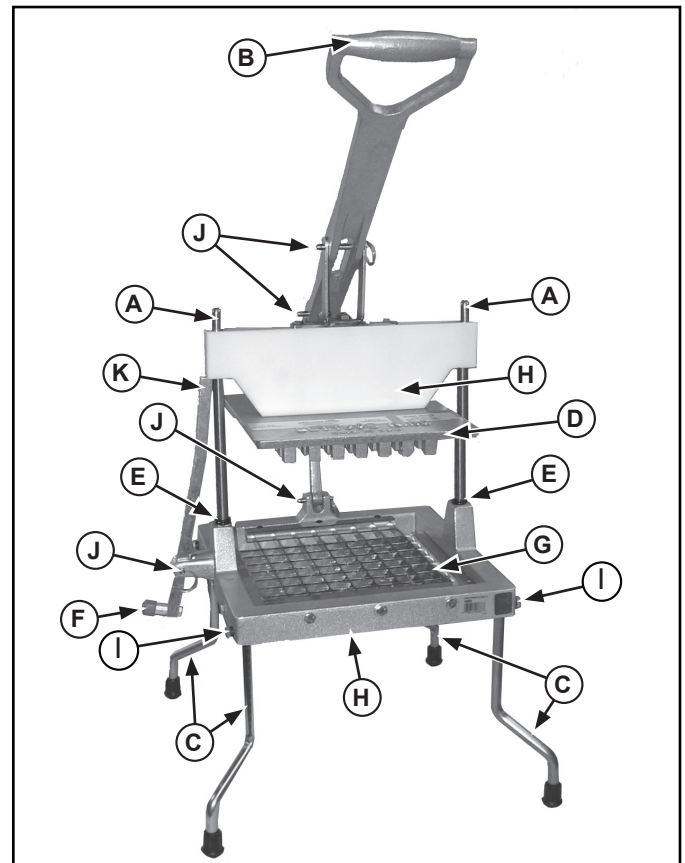

Figure 2. Features and Controls Lettuce King IV.



- (A) GUIDE RODS. Guides and align the pusher head onto the blade set.
- (B) HANDLE. Used to lower and raise the pusher head.
- (C) LEGS. Supports the equipment.
- (D) PUSHER HEAD ASSEMBLY. Made up of the guides and the pusher head block (and the handle for tabletop models).
- (E) BUMPERS. Cushions the stop of the pusher head.
- (F) SAFETY LOCK HANDLE. Used to secure the pusher head block in the up position.
- (G) BLADE ASSEMBLY. Houses the blades. Specifically sized to match the corresponding pusher head block.
- (H) BASE ASSEMBLY. Holds the guide rods and parts of the equipment.
- (I) LEG SCREWS. Holds the legs in place.
- (J) LOCKING PIN. Secures the pusher head to the handle. Secures the handle assembly to the base. Secures the safety lock to the base.
- (K) SAFETY LOCK ARM. Used to secure the pusher head block in the up position.

### UNPACKING THE EQUIPMENT AND INITIAL SETUP

Carefully remove crating or packaging materials from the equipment. Dispose of all packaging materials in an environmentally responsible manner.

#### Leg installation Lettuce King I:

1. Use the screws (A) and washers (B) to install legs (C) tightening with wrench (D). See Figure 3.

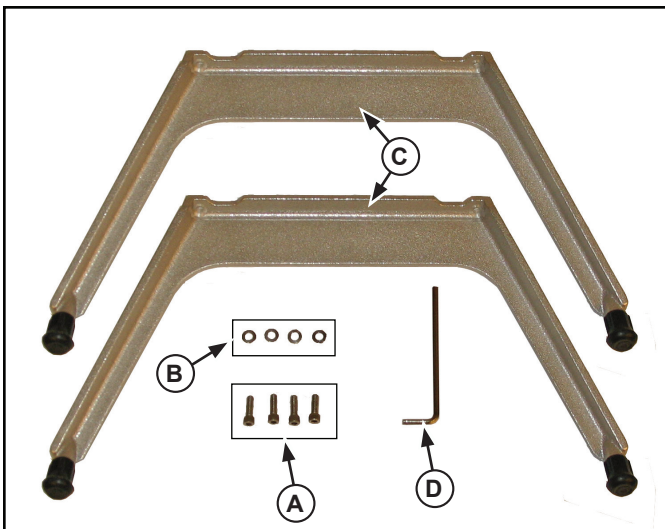

Figure 3. Legs, Hardware and Tool for the Lettuce King I.

2. Secure legs (C) to base (D) using screws (A) and washers (B). See Figure 4.

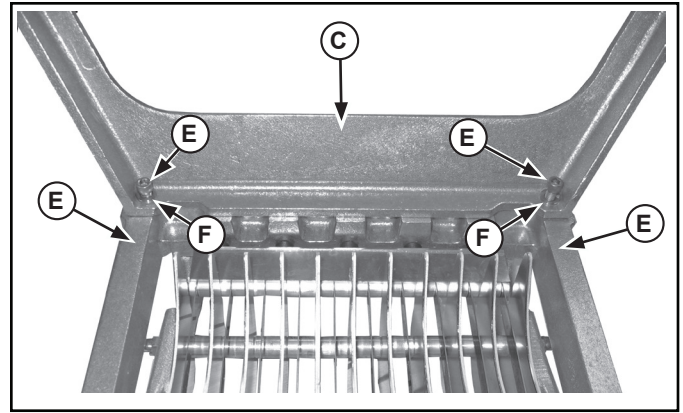

Figure 4. Mounting the Legs on the Lettuce King I.

#### Leg installation Lettuce King IV:

1. Use the capscrews (A) and rubber washers (B) to install legs (C). See Figure 5.

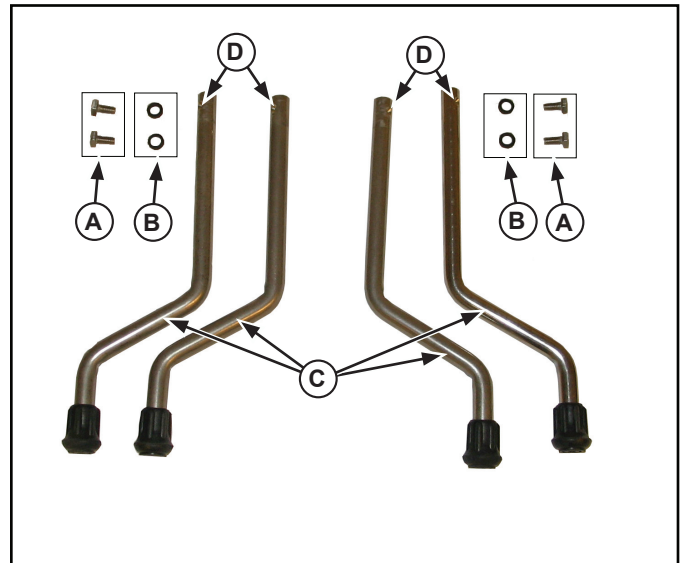

Figure 5. Legs and Hardware for the Lettuce King IV.

2. Use the capscrews (A) and rubber washers (B) to install legs (C). See Figure 5.
3. Set legs (C) into the holes in the base assembly (H) so the angled part of the leg faces outward. See Figure 2.
4. Secure legs (C) to base assembly (D) using screws (A) and rubber washers (B). See Figure 2.
5. Tighten capscrews (A) slowly and rotate the legs slightly so that the end of the capscrew (H) enters the notch in the leg (C). See Figure 5.

**OPERATION**

	<b>WARNING</b>
	<p><b>Sharp Blade Hazard.</b> Blades are sharp and can cause cuts. To avoid injury from sharp blades, handle with caution.</p>

Prior to first use, it is important to clean the equipment. Wash new blades with warm soapy water and rinse thoroughly to remove the thin protective oil film.

1. Before each use, check that the equipment is clean and the blades are in good condition. If loose or broken blades are found, blades must be serviced.
2. Before each use, always check for proper blade alignment. Slowly set the pusher head (D) onto the blade assembly. See Figures 1 and 2. They should slide together with no obstructions. If there are obstructions, verify they are a matching set.
3. Verify that the blade assembly and pusher head assembly are the desired size.
4. Prepare the food product to be processed.
5. Lift the handle (B) and place the food on the blade assembly (G) with the flat side down. See Figures 1 and 2.
6. **Lettuce King I:** Remove hand from the blade assembly (G) area and place that hand on the leg (C). See Figure 1.  
**Lettuce King IV:** Hold the handle (B), remove hand from the blade assembly area and place that hand on the lock lever (F). Push lock lever (F) in to release the lock arm from the (D). See Figure 2
7. Using a strong, quick, downward thrust, force the food product through the blade assembly.
8. Repeat this process until you have prepared enough food product for your daily needs.
9. Clean and lubricate your equipment immediately after each use. See the **CLEANING** section of this manual for more information.

**CLEANING**

	<b>WARNING</b>
	<p><b>Sharp Blade Hazard.</b> Blades are sharp and can cause cuts. To avoid injury from sharp blades, handle with caution.</p>

To maintain the appearance and increase the service life, clean your daily.

**NOTE:**

**Food acids will make blades dull and corrode the metal. Always clean this food preparation equipment immediately after every use.**

1. Raise the handle to put the highest position. See Figures 1 and 2.
2. Clean large excess pieces of scrap with the special brush provided with this equipment.
3. Wipe, rinse or spray off equipment, pusher head and blade assembly thoroughly with HOT water.

4. Do not wipe across the blades or use scrub pads on this equipment. Wiping across the sharp edge of the blade can cause injury and will dull the blades.
5. The blade assembly (G) is best cleaned by forcing water under pressure through the blades from the unsharpened side. If necessary, use a nylon bristle cleaning brush to push food particles out from the unsharpened side of the blade assembly (G).
6. Do not put this equipment in a dishwasher or dish machine with soaps, detergents, or other alkaline chemicals that can harm the equipment.
7. After cleaning, let the equipment air dry.
8. Lubricate the guide bar with mineral oil or Petro Gel after each use. Do not use cooking oil as it will become sticky and may permanently damage the equipment.

**PREVENTATIVE MAINTENANCE**

1. Clean equipment after every use.
2. Use for intended purposes only.
3. Change blades regularly - based on usage.

**REPLACING BLADE ASSEMBLY**

	<b>WARNING</b>
	<p><b>Sharp Blade Hazard.</b> Blades are sharp and can cause cuts. To avoid injury from sharp blades, handle with caution.</p>

Wash new blades with warm, soapy water and rinse thoroughly to remove the thin protective oil film. Keep the sharp edge away from you when handling blades.

**Lettuce King I:**

1. Familiarize yourself with the parts diagram for your equipment.
2. Allow ample room to work on a flat, dry surface.
3. Raise the handle and pusher head as far up as it will go.
4. Verify that the bumpers (E) are installed. If missing, clean the surface and install new blade block shield(s). See Figure 1.
5. Remove the screws retaining the blade assembly (T). Carefully remove and dispose the blade assembly. See Exploded View and Parts List.
6. Examine the pusher fingers (J). If they are nicked or burred, smooth the rough edges with a small flat file. The spaces between the fingers must be uniform. Straighten any bent fingers.
7. Verify that blade shields (V) are installed on the blade assembly. See.
8. Place the blade assembly (G) into the frame (H) so the it is seated correctly and the sharp side up. See Figure 1.
9. Install the screws into the rear side of the blade assembly (G). Tighten until contact is made with the base assembly (H). Turn the screw until tight, do not exceed 1/2 turn or 40 in. lbs.
10. Place rubber washer between the base assembly (H) and the blade assembly (G). Insert the screws through the frame, and rubber washer into the blade assembly. Turn the screw until tight, do not exceed 1/2 turn or 40 in. lbs.



11. Slowly bring the pusher head (D) down to the blade assembly (G). If there is contact, the pusher head may need to be adjusted. To adjust, loosen the locking collar setscrews and position then adjust the pusher head fingers. Tighten the locking collar setscrews.
  12. Lubricate the guide bar with mineral oil or Petro Gel after each use. Do not use cooking oil as it will become sticky and may permanently damage the equipment.
- Lettuce King IV:**
1. Familiarize yourself with the parts diagram for your equipment.
  2. Allow ample room to work on a flat, dry surface.
  3. Raise the handle and pusher head as far up as it will go.
  4. Remove the screws retaining the blade assemblies (I). Carefully remove and dispose the blade assemblies. See Figure 2.
  5. Examine the pusher head (D). If they are nicked or burred, smooth the rough edges with a small flat file.
  6. Verify that blade shields (BB) are installed on the blade assembly (DD and CC). See Exploded View for Lettuce King IV.
  7. Place the lower blade assembly (CC) into the frame (H) so the it is positioned correctly and the sharp side up.
  8. Install the screws into the left side of the blade assembly (CC). Tighten until contact is made with the frame (H). Turn the screw until tight, do not exceed 1/2 turn or 40 in. lbs.
  9. Place rubber washer between the right side frame (H) and the blade assembly (CC). Insert the screws through the frame, and rubber washer into the blade assembly. Turn the screw until tight, do not exceed 1/2 turn or 40 in. lbs.
  10. Place the upper blade assembly (DD) into the frame (H) so the it is positioned correctly and the sharp side up.
  11. Install the screws into the front side of the blade assembly (DD). Tighten until contact is made with the frame (H). Turn the screw until tight, do not exceed 1/2 turn or 40 in. lbs.
  12. Place rubber washer between the back side frame (H) and the blade assembly (DD). Insert the screws through the frame, and rubber washer into the blade assembly. Turn the screw until tight, do not exceed 1/2 turn or 40 in. lbs.
  13. Slowly bring the pusher head down to the blades.
  14. Lubricate the guide bar with mineral oil or Petro Gel after each use. Do not use cooking oil as it will become sticky and may permanently damage the equipment.

**TROUBLESHOOTING**

If the equipment no longer processes food cleanly or without damage to the food product, the blades could be dull and be in need of replacement. Broken, bent, or nicked blades must be replaced.

Problem	It might be caused by	Course of Action
Broken Blade.	Blades were dull.	Pre-score whenever possible to avoid undue shock and stress to blades Replace the blade assembly.

**SERVICE AND REPAIR**

Please contact the qualified professional repair service listed below.

**VOLLRATH Induction Repair Service • 1-800-825-6036 (USA) or [www.vollrathco.com](http://www.vollrathco.com)**

When contacting the Authorized Professional Service Center, please be ready with the model number, serial number, and proof of purchase showing the date the equipment was purchased.

**SPARE PARTS LIST - LETTUCE KING I**

LETTER	PART NUMBER	DESCRIPTION
A	060	RUBBER FOOT (OLD STYLE)
	303	RUBBER FOOT, DEEP (NEW STYLE)
B	0655	RUBBER SEAL
C	414	SCREW FIL. HEAD., 1/4-20 X 3/4"
D	415	SCREW, HEX HEAD., 1/4-20 X 7/8"
E	420	BLADE BLOCK
F	424	BLADE BLOCK PIN
G	426	LEG CASTING, FRONT / REAR
H	427	BLADE BLOCK SCREW, 1/4-20 X 2"
I	4422R	SCREW, SQ. HEAD., 1/4-20 X 3/8"
J	452	PUSHER HEAD 3/4" - INCLUDES: 20 SPACERS, 11 FINGERS, 2 RETAINING RODS, 4 NUTS
	482	PUSHER HEAD 3/8" - INCLUDES: 38 SPACERS, 20 FINGERS, 2 RETAINING RODS, 4 NUTS
	483	PUSHER HEAD 1/4" - INCLUDES: 56 SPACERS, 29 FINGERS, 2 RETAINING RODS, 4 NUTS
K	453	PUSHER HEAD LOCKING COLLAR - INCLDS. COLLAR & SCREW
L	454	PUSHER HEAD PIVOT ROD
M	455	PUSHER HEAD HANDLE - INCLDS. HANDLE ROD & 2 PLASTIC GRIPS
N	456	PUSHER HEAD SIDE ARM - RIGHT HAND
O	457	PUSHER HEAD SIDE ARM - LEFT HAND
P	468	BASE CASTING
Q	490	NYLON WASHER
R	506	PUSHER HEAD BUMPER
S	519	ACORN NUT, 1/4"
T	485	BLADE ASSEMBLY 1/4" - INCLUDES: 28 BLADES, 2 BLOCKS, 2 PINS, 2 SHIELDS
	484	BLADE ASSEMBLY 3/8" - INCLUDES: 19 BLADES, 2 BLOCKS, 2 PINS, 2 SHIELDS
	434	BLADE ASSEMBLY 3/4" - INCLUDES: 10 BLADES, 2 BLOCKS, 2 PINS, 2 SHIELDS
U	N/A	BLADE SHIELD - PART OF BLADE ASSEMBLY
NOT SHOWN	4425	LETTUCE CUTTER BRUSH



**SPARE PARTS LIST - LETTUCE KING I**

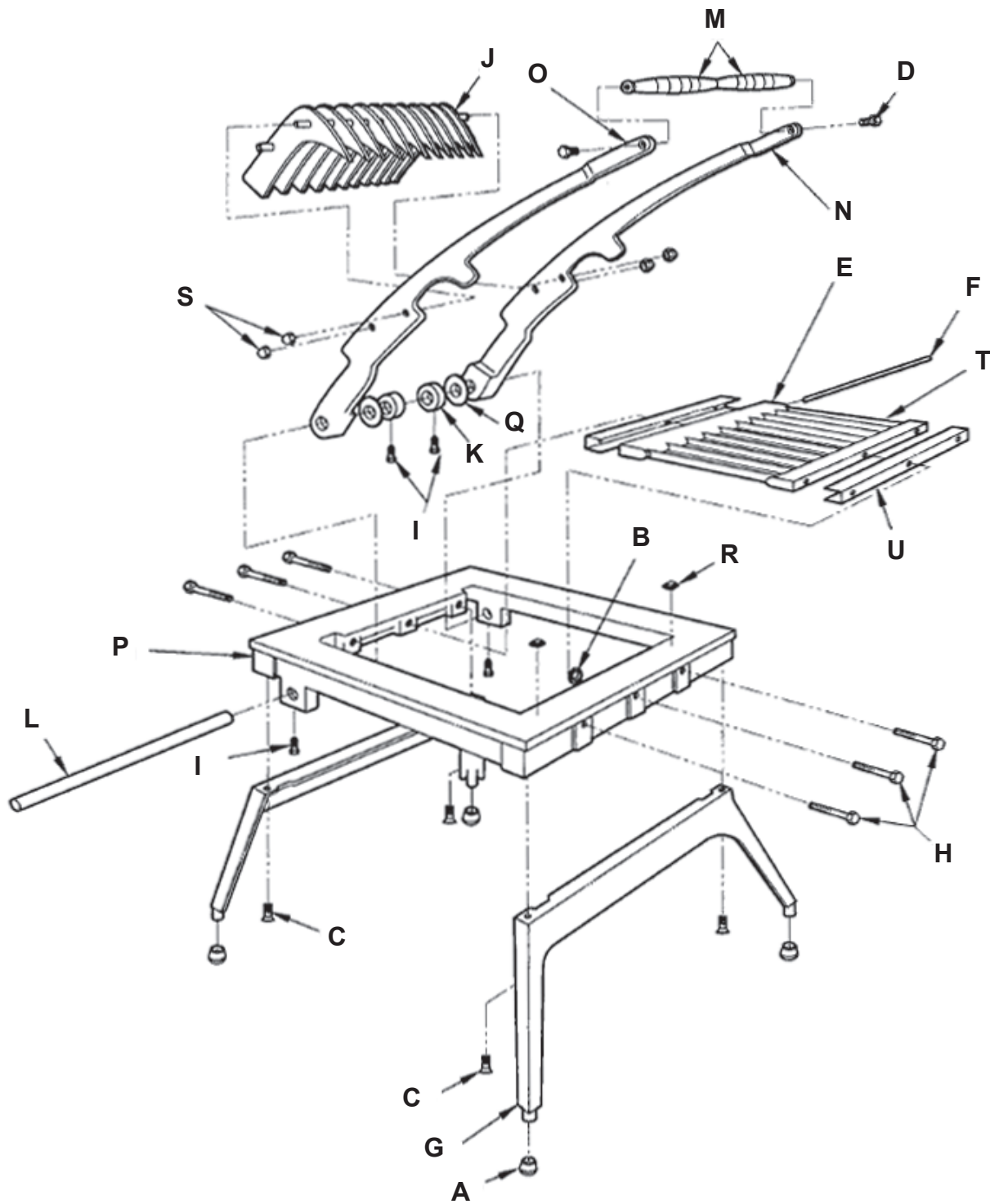

ENGLISH

**SPARE PARTS LIST - LETTUCE KING IV**

LETTER	PART NUMBER	DESCRIPTION
A	0658	Rubber Seal
B	303	Rubber Foot
C	305	"O" ring
D	379017	Handle Bracket
E	379018	Leg (new style - do not intermix with old style)
F	379019	Screw, Stainless, Hex, 3/8-24 x 1"
G	379020	Spacer
H	4401	Main frame with guide rods
I	4402	Blade Block (also part of 4408)
J	4403	Blade Pin (also part of 4408)
K	4404	Pusher Head
L	4405	Head Guide
M	4406	Screw, Hex, 1/4-20 x 4 1/2"
N	4407	Screw, Hex, 1/4-20 x 1 3/8"
O	4409	LEG (old style - do not intermix with new style)
P	4411	Pull Pin with ring, short, 1 1/4"
Q	4412R	Pull Pin with ring, long 1 3/4"
R	4413	Operating Arm linkage
S	4414R	Operating Handle
T	4416	Safety Pivot Bbase
U	4417	Safety Latch Assembly
V	4424	Screw, Hex, 1/4-20 x 1/2"
W	4427	Screw, Phillips, 1/4-20 x 1 1/4"
X	N/A	Plastic Cap (also part of 4417)
Y	N/A	Aluminum Stop (also part of 4417)
Z	N/A	Safety Latch (also part of 4417)
AA	N/A	Screw, Hex, 1/4-20 x 1" (also part of 4417)
BB	N/A	Blade Shield (part of blade assy 4408 & blade kit 4451)
CC	N/A	Blade Assembly (inclds. 2 complete blade assy's w/ shields)
DD	N/A	Single Blade, 1/2" x 9-3/16" (packed 12 per carton)
EE	N/A	Head Guide Link (discontinued, refer to "D")
NOT SHOWN	4425	Lettuce Cutter Brush



**SPARE PARTS LIST - LETTUCE KING IV**

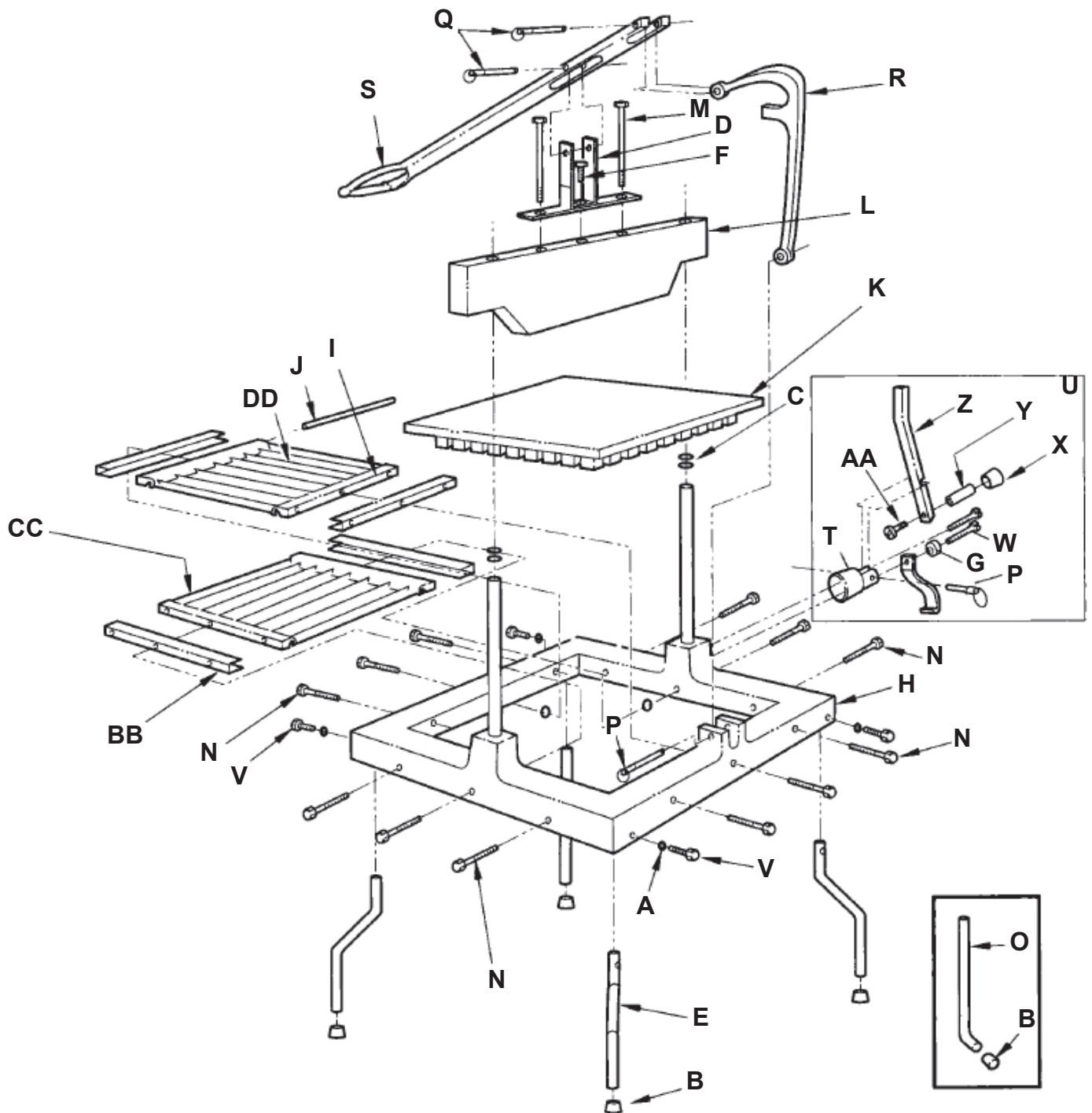

ENGLISH

**WARRANTY STATEMENT FOR THE VOLLRATH Co. L.L.C.**

The Vollrath Company LLC warrants the products it manufactures and distributes against defects in materials and workmanship for a period of one year, except as specifically provided below. The warranty runs 12 months from the date of original installation. (End user receipt)

1. Refrigeration compressors – The warranty period is 5 years.
2. Refrigerated Display Cases (RDE) compressors the warranty is 3 years.
3. Replacement parts – The warranty period is 90 days.
4. Aluminum Fry pans are 90 days.
5. EverTite™ Riveting System – The warranty covers loose rivets only, lifetime to original purchaser.
6. Cayenne® Heat Strips – The warranty period is 1 year plus an additional 1 year period on heating element parts only.
7. Ultra, Ultra Fajita, Mirage® Pro and Professional Induction Ranges – The warranty period is 2 years.
8. Mirage®, Mirage® Cadet, Mirage® Fajita and Commercial Induction ranges - The warranty period is 1 year.
9. ServeWell® Induction Workstations – The warranty period is 1 year on the workstation table and 2 years on induction hobs.
10. Slicers – The warranty period is 10 years on gears and 5 years on belts.
11. Mixers – The warranty period is 2 yrs parts, 1 yr labor and belts are 5 years.
12. Extended warranties are available on a limited basis and must be agreed to prior to closing the sale.
13. Vollrath – Redco products – The warranty period is 2 years.
14. Optio / Arkadia product lines – The warranty period is 90 days.
15. All non-stick products (i.e. fry pans and surfaces) are 90 days for the non stick surfaces.
16. All TRAEX® product warranty (with the exception of T-REX™) is 1 year.
17. T-REX™ product by TRAEX® is lifetime warranty.

All products in the Jacob's Pride® collection, including the following, have a lifetime warranty:

- NSF Certified One-Piece Dishers
- NSF Certified Spoodle® Utensils
- NSF Certified Heavy-Duty Spoons with Ergonomic Handle
- NSF Certified Heavy-Duty Basting Spoons
- Heavy duty Turners with Ergonomic handle
- One-Piece Tongs\*
- Heavy-Duty One-Piece Ladles\*
- Nylon Handle Whips
- One-Piece Skimmers
- Tribute®, Intrigue®, and Classic Select® Cookware\*

\*Jacob's Pride® warranty does not cover Kool-Touch®, non stick coatings and silicone handles.

**Items sold having no warranty:**

- Meat Grinder Knives
- Light Bulbs in Convection Ovens and Hot Food Merchandiser
- Oven Door Seals
- Oven Door Glass
- Hot Food Merchandisers / Display Case Glass
- Calibration and set up of gas equipment
- Slicer / Dicer blades (table top food prep) – Redco and Vollrath

**THIS WARRANTY IS IN LIEU OF ANY OTHER WARRANTIES, EXPRESS OR IMPLIED, INCLUDING ANY IMPLIED WARRANTY OF MERCHANTABILITY OR FITNESS FOR A PARTICULAR PURPOSE**

As The Vollrath Company LLC's only responsibility and the purchaser's only remedy, for any breach of warranty, The Vollrath Company LLC will repair or, at its option, replace the defective product or part without charge, except as otherwise provided below:

- For refrigeration compressors and the second year of the warranty on Cayenne® Heat Strips and mixers, The Vollrath Company LLC will provide the repaired or replacement part only; and the buyer will be responsible for all labor charges incurred in performing the repair or replacement.
- To obtain warranty service, the buyer will be responsible to return to The Vollrath Company LLC any product (other than gas equipment that is permanently installed) weighing less than 110 lbs. or located outside of a 50-mile radius of a certified technician designated by The Vollrath Company LLC to perform warranty repairs. If a Vollrath Technician cannot be contacted check the website for service contact points. (Please refer to the Product Catalogue for weights and sizes of product)
- No remedy will be available for products that have been damaged by accident, carelessness, improper installation, lack of proper setup or supervision when required, neglect, improper use, installation or operation contrary to installation and operating instructions or other causes not arising out of defects in materials or workmanship. At the buyer's request, The Vollrath Company LLC will repair and or replace such products at a reasonable cost.
- No remedy will be available for slicers where blade has not been sharpened (Refer to owner's manual for sharpening instructions)
- No remedy will be available for mixers damaged by changing gears while equipment is running or overloading, in either case as determined by a Vollrath Certified Technician
- Warranty work must be authorized in advance by The Vollrath Company LLC. See the operating and safety instructions for each product for detailed warranty claim procedures.
- No remedy will be available for product returned and found to be acceptable to the product specification.
- No remedy will be available under any warranty not registered as required below.

**LIMITATION OF LIABILITY:**

**THE VOLLRATH COMPANY LLC SHALL HAVE NO LIABILITY FOR INCIDENTAL OR CONSEQUENTIAL DAMAGES OF ANY KIND, WHETHER BASED UPON NEGLIGENCE OR OTHER TORT, BREACH OF WARRANTY, OR ANY OTHER THEORY.**



## WARRANTY PROCEDURE

On all warranty calls, the following process and information is required:

- All warranty claims will start with a call to Vollrath Technical Service support line.(800-628-0832).
- A technical support professional will work to diagnose the issues, and provide the details for the service solution.
- Name and phone number of person calling
- Business name, street address, city, state and zip
- Model and serial number
- Date of purchase and proof of purchase (Receipt)
- Name of dealer where unit was purchased

NOTE: Vollrath will not accept products sent without the proper procedure being followed.

**Important:**

TO MAKE A CLAIM FOR ANY REMEDY UNDER THIS WARRANTY, YOU MUST REGISTER YOUR WARRANTY.

## REGISTER TODAY

ONLINE: Register your warranty on-line now at [www.Vollrathco.com](http://www.Vollrathco.com)

NO WEB ACCESS: If you do not have access to the web, kindly register by completing the warranty registration form and faxing it to The Vollrath Co. LLC office in the country of purchase.

WARRANTY REGISTRATION			
BUSINESS NAME			
KEY CONTACT NAME		EMAIL	
STREET ADDRESS			
CITY	STATE	ZIP CODE	
COUNTRY	PHONE	FAX	
MODEL		ITEM NUMBER	
SERIAL NUMBER	-	-	
OPERATION TYPE			
<input type="checkbox"/> Limited Service Restaurant	<input type="checkbox"/> Full Service Restaurant	<input type="checkbox"/> Bars and Taverns	<input type="checkbox"/> Supermarket
<input type="checkbox"/> Convenience Store	<input type="checkbox"/> Recreation	<input type="checkbox"/> Hotel/Lodging	<input type="checkbox"/> Airlines
<input type="checkbox"/> Business/Industry	<input type="checkbox"/> Primary/Secondary School	<input type="checkbox"/> Colleges/University	<input type="checkbox"/> Hospitals
<input type="checkbox"/> Long-Term Care	<input type="checkbox"/> Senior Living	<input type="checkbox"/> Military	<input type="checkbox"/> Corrections
REASON FOR SELECTING OUR PRODUCT			
<input type="checkbox"/> Appearance	<input type="checkbox"/> Full Service Restaurant	<input type="checkbox"/> Availability	<input type="checkbox"/> Sellers Recommendation
<input type="checkbox"/> Ease of Operation	<input type="checkbox"/> Versatility of Use	<input type="checkbox"/> Price	<input type="checkbox"/> Brand
WOULD YOU LIKE TO RECEIVE OUR FULL-LINE CATALOG AND REMAIN ON OUR MAILING LIST?			<input type="checkbox"/> Yes <input type="checkbox"/> No

ENGLISH



[www.vollrathco.com](http://www.vollrathco.com)

The Vollrath Company, L.L.C.  
1236 North 18th Street  
Sheboygan, WI 53081-3201  
U.S.A.

Main Tel: 800.628.0830  
Fax: 800.752.5620

Technical Services: 800.628.0832  
Service Fax: 920.459.5462

Canada Service: 800.695.8560

© 2012 The Vollrath Company, L.L.C.

