

Operator's Manual

DRAIN KIT

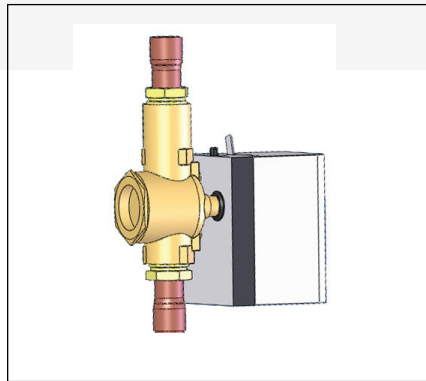

Item	Description	Voltage	For Use With
36672auto	Auto Manifold Drain Kit, 2 Well	120V	3667201D or 3667202D
36673auto	Auto Manifold Drain Kit, 3 Well	120V	3667301D or 3667302D
36674auto	Auto Manifold Drain Kit, 4 Well	120V	3667402D
36674man	Manual Manifold Drain Kit, 2-4 Well	N/A	N/A

Thank you for purchasing this Vollrath equipment. Before operating the equipment, read and familiarize yourself with the following operating and safety instructions. SAVE THESE INSTRUCTIONS FOR FUTURE REFERENCE. Save the original box and packaging. Use this packaging to ship the equipment if repairs are needed.

SAFETY PRECAUTIONS

To ensure safe operation, read the following statements and understand their meaning. Please read carefully.

WARNING

Warning is used to indicate the presence of a hazard that *can* cause severe personal injury, death, or substantial property damage if the warning is ignored.

CAUTION

Caution is used to indicate the presence of a hazard that *will* or *can* cause *minor* personal injury or property damage if the caution is ignored.

NOTE

Note is used to notify people of installation, operation, or maintenance information that is important but not hazard-related.

For Your Safety!

These precautions should be followed at all times. Failure to follow these precautions could result in injury to yourself and others.

To reduce risk of injury or damage to the equipment:

- Read and understand all installation and operation instructions before installing or operating equipment.
- This equipment must be installed by a licensed electrician or certified service personnel.
- Prior to installation the unit must be unplugged from its power source.
- Use only grounded electrical outlets matching the nameplate rated voltage.
- Do not spray controls or outside of equipment with liquids or cleaning agents.
- Keep equipment and power cord away from open flames, electric burners or excessive heat.

FUNCTION AND PURPOSE

Drain kits 36672auto, 36673auto, 36674auto and 36674man are designed to be installed on Vollrath Hot/Cold Well models only. Check vollrathco.com for product list.

This product is intended to drain the water from a well.

This equipment is not intended for household, industrial or laboratory use.

OPERATIONAL STATEMENT

The Auto Drain units operate by emptying the reservoir after the mode switch on the unit is moved to the refrigeration mode. When the well control switch is in the refrigerate mode the valve stays in the “open” position. When the well control switch is in the center or heat position the valve remains in the “closed” position.

The Manual Drain units require an operator to manually install a drain plug in order for the well to hold water or to remove the drain plug to allow the water to drain.

UNPACKING THE EQUIPMENT AND INITIAL SETUP

When no longer needed, dispose of all packaging and materials in an environmentally responsible manner. Have the unit installed only by qualified service personnel. This unit must be installed in accordance with any local and national plumbing codes. See back of this document for kit contents.

Tools and Supplies Required:

- #2 Flat Blade Screwdriver
- #2 Phillips Screwdriver
- Wire Stripper
- Pipe Wrench or Pliers
- Silicone, High Temperature, NSF Listed
- Utility Knife

Installation of Auto Drain Model Kits:

1. Turn power switch to the “OFF” position and unplug from power source.
2. Remove all water from the wells.
3. Remove the stub pipe (B) by unscrewing it from the well bottom (A). See Figure 1.

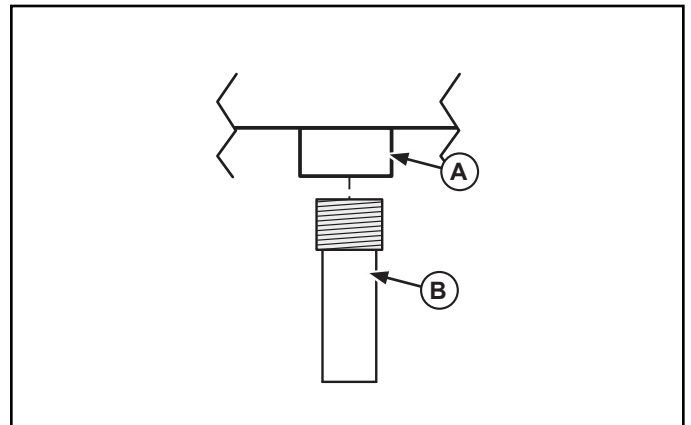

Figure 1. Removal of Stub Pipe.

4. Place a small bead of high temperature NSF listed silicone on the threads on fitting (B) of the valve assembly (C). See Figure 2.

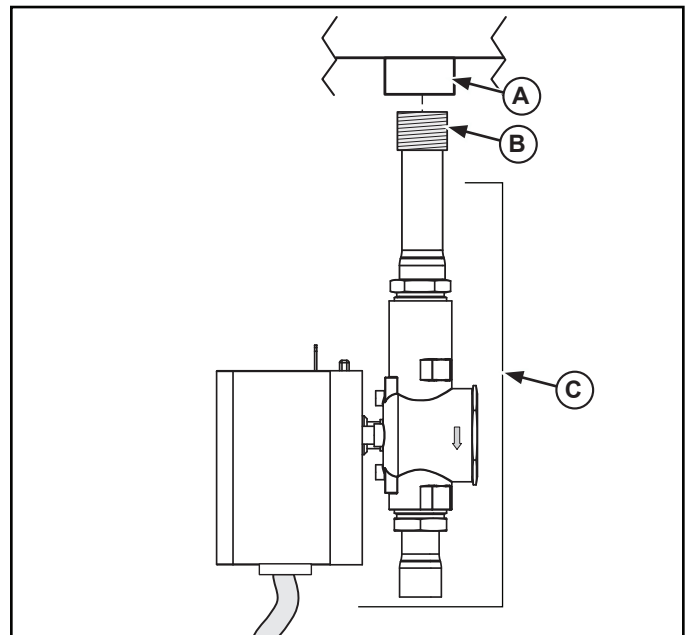

Figure 2. Manifold Assembly and Well Fitting.



5. Thread the fitting (B) into the well bottom (A) and tighten.
6. Repeat steps 2-5 as necessary to install more valves.
7. Remove the hardware securing the cover (A) on the wire channel box (D). See Figure 3.

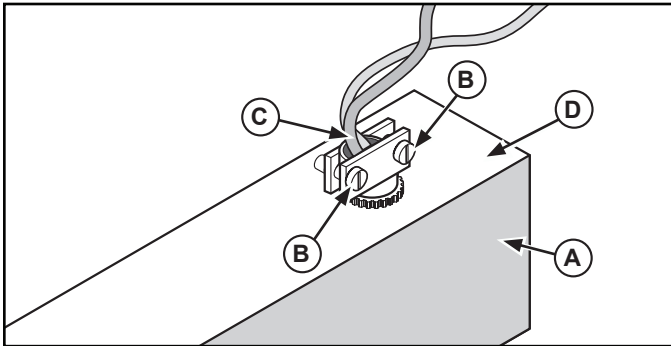

Figure 3. Strain Relief Screws, Wire Channel Box and Wires.

8. Loosen the screws (B) on the strain relief.
9. Route the auto drain cords (C) through the strain reliefs.

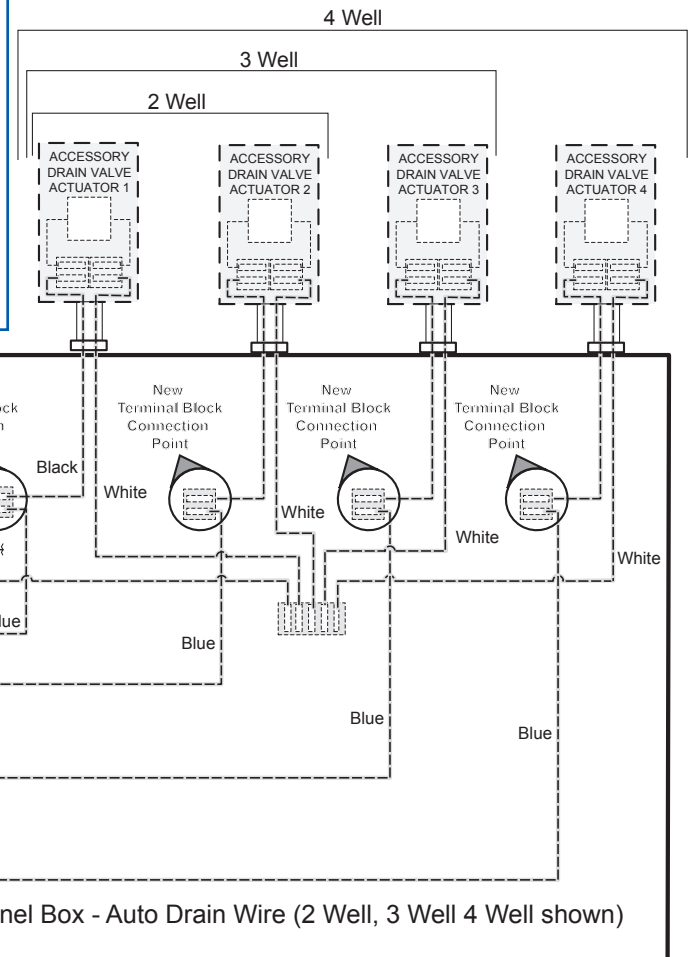

Figure 4. Electrical Connections.

10. Make the connections as shown in Figure 4 using the lever connectors and blue and white wire(s) provided. Also refer to unit wiring diagram.
11. To use the lever connectors (See Figure 5):

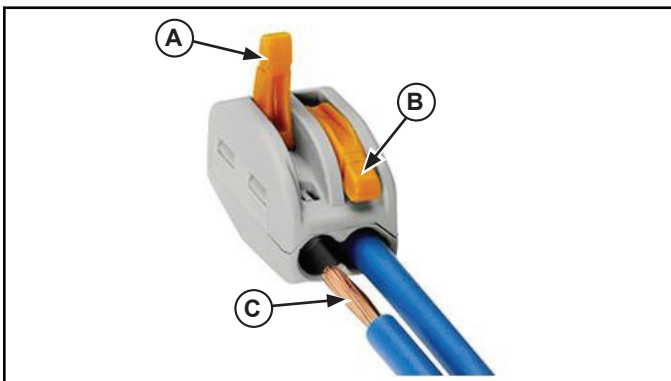

Figure 5. Lever Connector.

12. Strip 3/8" (10 mm) of insulation (C) from the wire. There is a gauge that shows the correct measurement to be stripped on the lever connector. Twist the exposed wire slightly so that it stays together inside the connector.
13. Lift lever to the up position (A).
14. Insert the stripped portion of wire into the lever connector and put lever into the closed position (B). **No bare wire can be exposed from the connector.**
15. After all the connections have been made secure the cover (A) onto the wire channel box (D) using the hardware that was removed earlier. Figure 3.
16. Tighten the screws (B) by hand to prevent cutting the wire insulation. See Figure 3.

ENGLISH

- Cut and install the drain tubing (C), "T" fittings (D) and clamps (B) as needed and route to drain. See Figure 6.

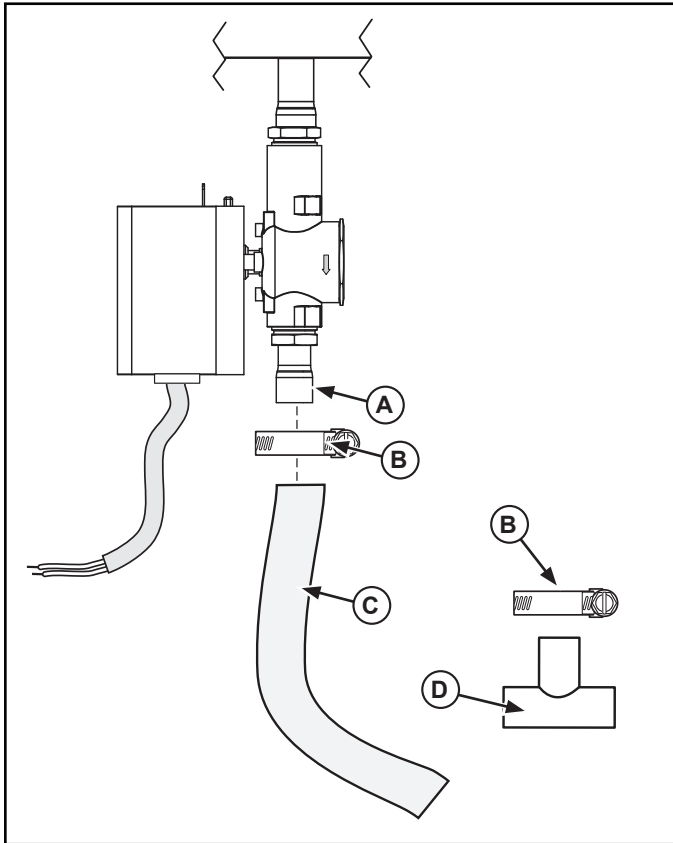

Figure 6. Drain Tube, Clamp and "T" Fitting.

- Tighten all clamps.
- Install the unit, read and follow the Operator's Manual instructions for safe and correct use.
- Pour 1/4 cup of clean fresh water into each well drain. Switch the mode control to refrigeration. See Operator's manual. Turn the power switch to the "ON" mode. Water should drain. Repeat for all wells.

Installation of Manual Drain Model Kits:

- Turn power switch to the "OFF" position and unplug from power source.
- Remove all water from the wells.

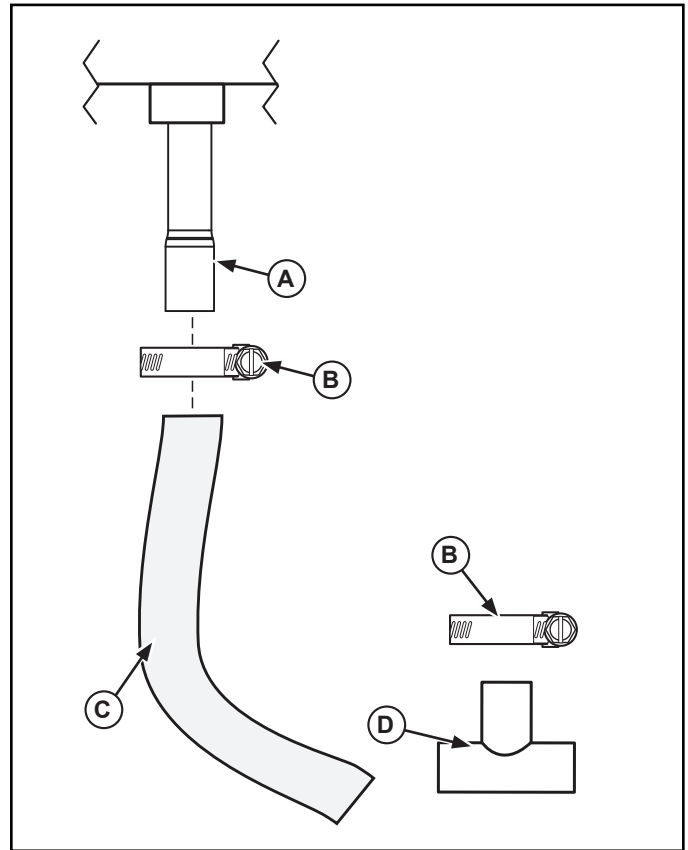

Figure 7. Water Reservoir and Well Assembly.

- Cut and install the drain tubing (C), "T" fittings (D) and clamps (B) as needed and route to drain. See Figure 7.
- Tighten all clamps.
- Install the manual "drain plug(s)" provided in the well bottoms to hold water in the wells. See operation of manual drain plug on following page.
- Wait until the water in the well has completely cooled before removing the manual "drain plug(s)".



Operation of the Manual Drain Plug:

To install the manual drain plug:

1. Install the drain plug assembly into the drain hole of the well (C). See Figure 7.
2. If necessary hold shaft (A) and tighten the wing nut (B). This will expand the rubber collars (D). Turn the wing nut until it is snug.

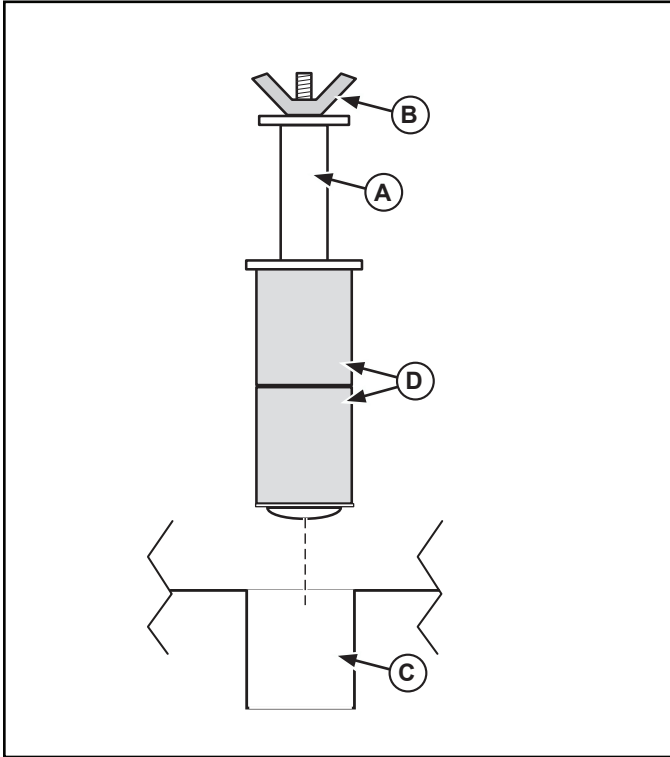

Figure 7. Manual Drain Plug.

To remove the manual drain plug:

1. If necessary hold shaft (A) and loosen the wing nut (B). This will contract the rubber collars (D). Turn wing nut until it is loose.
2. Remove the drain plug from the drain hole in the well (C).

36672 Auto Drain Kit		
Callout	Quantity	Description
1	13	Hose Clamps
2	3	"T" Fittings
3	Bulk	7/8" I.D. Drain Hose
4	1	Connector, 3 Wire
5	2	Connector, 2 Wire
6	2	Drain Valve Assembly
N/S	1	48" White Wire, 16 GA
N/S	2	48" Blue Wire, 16 GA

ENGLISH

36673 Auto Drain Kit		
Callout	Quantity	Description
1	13	Hose Clamps
2	3	"T" Fittings
3	Bulk	7/8" I.D. Drain Hose
4	1	Connector, 5 Wire
5	3	Connector, 2 Wire
6	3	Drain Valve Assembly
N/S	1	48" White Wire, 16 GA
N/S	3	48" Blue Wire, 16 GA

36674 Auto Drain Kit		
Callout	Quantity	Description
1	13	Hose Clamps
2	3	"T" Fittings
3	Bulk	7/8" I.D. Drain Hose
4	2	Connector, 3 Wire
5	4	Connector, 2 Wire
6	4	Drain Valve Assembly
N/S	2	48" White Wire 16 GA
N/S	4	48" Blue Wire, 16 GA

36674 Manual Drain Kit		
Callout	Quantity	Description
1	13	Hose Clamps
2	3	"T" Fittings
3	Bulk	7/8" I.D. Drain Hose
4	4	Drain Plugs



WARRANTY STATEMENT FOR THE VOLLRATH Co. L.L.C.

The Vollrath Company LLC warrants the products it manufactures and distributes against defects in materials and workmanship for a period of one year, except as specifically provided below. The warranty runs 12 months from the date of original installation. (End user receipt)

1. Refrigeration compressors – The warranty period is 5 years.
2. Replacement parts – The warranty period is 90 days.
3. Fry pans and coated cookware – The warranty period is 90 days
4. EverTite™ Riveting System – The warranty covers loose rivets only, forever.
5. Cayenne® Heat Strips – The warranty period is 1 year plus an additional 1 year period on heating element parts only.
6. Ultra and Professional Induction Ranges – The warranty period is 2 years.
7. Mirage and Commercial Induction ranges - The warranty period is 1 year.
8. ServeWell® Induction Workstations – The warranty period is one year on the workstation table and 2 years on induction hobs.
9. Slicers – The warranty period is 10 years on gears and 5 years on belts.
10. Mixers – The warranty period is 2 years.
11. Extended warranties are available at the time of sale.
12. Vollrath – Redco products – The warranty period is 2 years.
13. Optio / Arkadia product lines – The warranty period is 90 days.
14. All non-stick products (i.e. fry pans and surfaces) are 90 days for the non stick surfaces.

All products in the Jacob's Pride® collection, including the following, have a lifetime warranty:

- NSF Certified One-Piece Dishers
- NSF Certified Spoodle® Utensils
- NSF Certified Heavy-Duty Spoons with Ergonomic Handle
- NSF Certified Heavy-Duty Basting Spoons
- Heavy duty Turners with Ergonomic handle
- One-Piece Tongs*
- Heavy-Duty One-Piece Ladles*
- Nylon Handle Whips
- One-Piece Skimmers
- Tribute®, Intrigue®, and Classic Select® Cookware*

*Jacob's Pride® warranty does not cover Kool-Touch®, non stick coatings and silicone handles.

Items sold having no warranty:

- Meat Grinder Knives
- Light Bulbs in Convection Ovens and Hot Food Merchandiser
- Oven Door Seals
- Oven Door Glass
- Hot Food Merchandisers / Display Case Glass
- Calibration and set up of gas equipment
- Slicer / Dicer blades (table top food prep) – Redco and Vollrath

THIS WARRANTY IS IN LIEU OF ANY OTHER WARRANTIES, EXPRESS OR IMPLIED, INCLUDING ANY IMPLIED WARRANTY OF MERCHANTABILITY OR FITNESS FOR A PARTICULAR PURPOSE

As The Vollrath Company LLC's only responsibility and the purchaser's only remedy, for any breach of warranty, The Vollrath Company LLC will repair or, at its option, replace the defective product or part without charge, except as otherwise provided below:

- For refrigeration compressors and the second year of the warranty on Cayenne® Heat Strips and mixers, The Vollrath Company LLC will provide the repaired or replacement part only; and the buyer will be responsible for all labor charges incurred in performing the repair or replacement.
- To obtain warranty service, the buyer will be responsible to return to The Vollrath Company LLC any product (other than gas equipment that is permanently installed) weighing less than 110 lbs. or located outside of a 50-mile radius of a certified technician designated by The Vollrath Company LLC to perform warranty repairs. If a Vollrath Technician cannot be contacted check the website for service contact points. (Please refer to the Product Catalogue for weights and sizes of product)
- No remedy will be available for products that have been damaged by accident, carelessness, improper installation, lack of proper setup or supervision when required, neglect, improper use, installation or operation contrary to installation and operating instructions or other causes not arising out of defects in materials or workmanship. At the buyer's request, The Vollrath Company LLC will repair and or replace such products at a reasonable cost.
- No remedy will be available for slicers where blade has not been sharpened (Refer to owner's manual for sharpening instructions)
- No remedy will be available for mixers damaged by changing gears while unit is running or overloading, in either case as determined by a Vollrath Certified Technician
- Warranty work must be authorized in advance by The Vollrath Company LLC. See the operating and safety instructions for each product for detailed warranty claim procedures.
- No remedy will be available for product returned and found to be acceptable to the product specification.
- No remedy will be available under any warranty not registered as required below.

LIMITATION OF LIABILITY:

THE VOLLRATH COMPANY LLC SHALL HAVE NO LIABILITY FOR INCIDENTAL OR CONSEQUENTIAL DAMAGES OF ANY KIND, WHETHER BASED UPON NEGLIGENCE OR OTHER TORT, BREACH OF WARRANTY, OR ANY OTHER THEORY.

ENGLISH

WARRANTY PROCEDURE

On all warranty calls, the following process and information is required:

- All warranty claims will start with a call to Vollrath Technical Service support line.(800-354-1970).
- A technical support professional will work to diagnose the issues, and provide the details for the service solution.
- Name and phone number of person calling
- Business name, street address, city, state and zip
- Model and serial number
- Date of purchase and proof of purchase (Receipt)
- Name of dealer where unit was purchased

NOTE: Vollrath will not accept products sent without the proper procedure being followed.

Important:

TO MAKE A CLAIM FOR ANY REMEDY UNDER THIS WARRANTY, YOU MUST REGISTER YOUR WARRANTY.

REGISTER TODAY

ONLINE: Register your warranty on-line now at www.Vollrathco.com

NO WEB ACCESS: If you do not have access to the web, kindly register by completing the warranty registration form and faxing it to The Vollrath Co. LLC office in the country of purchase.

WARRANTY REGISTRATION			
BUSINESS NAME			
KEY CONTACT NAME		EMAIL	
STREET ADDRESS			
CITY	STATE	ZIP CODE	
COUNTRY	PHONE	FAX	
MODEL		ITEM NUMBER	
SERIAL NUMBER			
OPERATION TYPE			
<input type="checkbox"/> Limited Service Restaurant	<input type="checkbox"/> Full Service Restaurant	<input type="checkbox"/> Bars and Taverns	<input type="checkbox"/> Supermarket
<input type="checkbox"/> Convenience Store	<input type="checkbox"/> Recreation	<input type="checkbox"/> Hotel/Lodging	<input type="checkbox"/> Airlines
<input type="checkbox"/> Business/Industry	<input type="checkbox"/> Primary/Secondary School	<input type="checkbox"/> Colleges/University	<input type="checkbox"/> Hospitals
<input type="checkbox"/> Long-Term Care	<input type="checkbox"/> Senior Living	<input type="checkbox"/> Military	<input type="checkbox"/> Corrections
REASON FOR SELECTING OUR PRODUCT			
<input type="checkbox"/> Appearance	<input type="checkbox"/> Full Service Restaurant	<input type="checkbox"/> Availability	<input type="checkbox"/> Sellers Recommendation
<input type="checkbox"/> Ease of Operation	<input type="checkbox"/> Versatility of Use	<input type="checkbox"/> Price	<input type="checkbox"/> Brand
WOULD YOU LIKE TO RECEIVE OUR FULL-LINE CATALOG AND REMAIN ON OUR MAILING LIST?			<input type="checkbox"/> Yes <input type="checkbox"/> No



www.vollrathco.com

The Vollrath Company, L.L.C.
1236 North 18th Street
Sheboygan, WI 53081-3201
U.S.A.

Main Tel: 800.628.0830
Fax: 800.752.5620

Technical Services: 800.628.0832
Service Fax: 920.459.5462

Canada Service: 800.695.8560

© 2012 The Vollrath Company, L.L.C.