



C24EO5 SHOWN

C24EO SERIES ELECTRIC COUNTERTOP STEAMERS

C24EO3	ML-136006
C24EO5	ML-136007

AUTOFILL (OPTION)

C24EO3	ML 152054
C24EO5	ML 152055

- NOTICE -

This Manual is prepared for the use of trained Hobart Service Technicians and should not be used by those not properly qualified.

This manual is not intended to be all encompassing. If you have not attended a Hobart Service School for this product, you should read, in its entirety, the repair procedure you wish to perform to determine if you have the necessary tools, instruments and skills required to perform the procedure. Procedures for which you do not have the necessary tools, instruments and skills should be performed by a trained Hobart Service Technician.

The reproduction, transfer, sale or other use of this manual, without the express written consent of Hobart, is prohibited.

This manual has been provided to you by ITW Food Equipment Group LLC ("ITW FEG") without charge and remains the property of ITW FEG, and by accepting this manual you agree that you will return it to ITW FEG promptly upon its request for such return at any time in the future.

TABLE OF CONTENTS

SERVICE UPDATES	4
SERVICE UPDATES	4
TIS DOCUMENT LIST - C24EO SERIES ELECTRIC COUNTERTOP STEAMERS	4
GENERAL	6
INSTALLATION, OPERATION AND CLEANING	6
INTRODUCTION	6
FEATURES	6
STEAM COOKING	6
MODEL DESIGNATIONS	6
EXTERIOR DIMENSIONS	6
SPECIFICATIONS	6
TOOLS	6
REMOVAL AND REPLACEMENT OF PARTS	8
COVERS AND PANELS	8
COMPONENT PANEL COMPONENTS	9
TIMER	9
HOLD THERMOSTAT	9
HIGH LIMIT THERMOSTAT	10
LOW WATER THERMOSTAT	11
TEMPERATURE PROBE	11
HEATING ELEMENT ASSEMBLY - REPLACEMENT ELEMENTS	11
THREADED STUD MOUNTING OF HEATER ASSEMBLY	11
SPRING MOUNTED HEATER ASSEMBLY (FIRST PRODUCTION)	15
MANUAL DRAIN VALVE	16
DOOR	17
DOOR GASKET	17
DOOR HANDLE	17
DOOR LATCH ASSEMBLY	18
DOOR HINGE BEARINGS	20
REMOVAL AND REPLACEMENT (AUTOFILL OPTIONAL)	21
PROBES	21
SOLENOID VALVES	22
WATER LEVEL ALARM	23
AUTOFILL CONTROL ASSEMBLY	23
SERVICE PROCEDURES AND ADJUSTMENTS	25
DOOR LATCH ADJUSTMENT	25
OPENING A JAMMED DOOR	25
ADJUSTMENT	25
HEATING ELEMENT TEST	26
TEMPERATURE CONTROL CALIBRATION	26
ELECTRICAL OPERATION	28
COMPONENT FUNCTION	28
COMPONENT LOCATION	29
SEQUENCE OF OPERATION	31
TIMED COOKING MODE	31
CONSTANT COOKING MODE	32
SCHEMATIC DIAGRAM	35
WIRING DIAGRAMS - HEATING ELEMENTS	37
C24EO3 - 208V/240V	37
C24EO5 - 208V/240V	38
C24EO5 - 480V	39

TROUBLESHOOTING 41
TROUBLESHOOTING 41

SERVICE UPDATES

SERVICE UPDATES

March 2021

Added Autofill section to SEQUENCE OF OPERATION.

March 2020

Added Notice SOLENOID VALVES.

February 2020

Added

PROBES.

SOLENOID VALVES

WATER LEVEL ALARM

AUTOFILL CONTROL ASSEMBLY

Updated

SCHEMATIC DIAGRAM

TIS DOCUMENT LIST - C24EO SERIES ELECTRIC COUNTERTOP STEAMERS

SERVICE TAB	
Document Title	Document Type
C24EO SERIES ELECTRIC COUNTERTOP STEAMERS Service Manual	Service Manual

SERVICE TAB (Multimedia)	
Document Title	Document Type
All Stainless Steel with Automatic Timers & Manual Boilers Direct Steam - ST. STL. LEG, Pedestal or Wall Mounted Owners Manual	Instructions
Electric Boiler Owners Manual	Instructions
Repair Flood-Damaged Food Equipment	Misc
C24EO3 & C24EO5 Electric Countertop Steamers Installation & Operation Manual	Operator
Fundamentals of Steam	Service Instructions
Fundamentals of Gas	Service Instructions
Hobart Water Filter Replacement Cross Reference Sheet	Service Instructions
Pilot & Burner Problems on Units Without Powered Burners Service Information	Service Instructions
ScaleStick Twin System, Part No. 01-234301-51200	Service Instructions

SERVICE TAB (Multimedia)	
Water Level Pressure Switches Information	Service Instructions
HC24EO & C24EO - Heating Element Kit Installation	Service Manual
Rating Plate Locations on Current Vulcan-Hart/Wolf Range Equipment	Technical Service Bulletin (TSB)
SB630 Gas Range Thermocouples	Technical Service Bulletin (TSB)
SB760 Vulcan Steam Temporary Service Instruction / Inspect All Warrick Water Level	Technical Service Bulletin (TSB)
SB800 Vulcan Steam Equipment - Enhanced Ignition Modules	Technical Service Bulletin (TSB)
SB860 Atmospheric Steamer Door Switch Actuator Rod	Technical Service Bulletin (TSB)
TSB 1374 Water Level Control Part No. 844069-1 Changes	Technical Service Bulletin (TSB)
TSB 1393 Steam Cooking Equipment - Prevention, Detection and Treatment of Corrosion on Stainless Steel	Technical Service Bulletin (TSB)
TSB 1037A Hobart to Vulcan "Common" Model Cross Reference List	Technical Service Bulletin (TSB)
TSB 1298A Atmospheric Steamer Door Switch Actuator Rod	Technical Service Bulletin (TSB)
TSB 1339 Vulcan High Efficiency Gas Steamers - Burner Noise	Technical Service Bulletin (TSB)
Hobart & Vulcan Steamers/Kettles with Warrick Water Level Control Boards	Temporary Service Instructions (TSI)
Steamers - Main Transformer Primary Tap on Electric Machines	Temporary Service Instructions (TSI)
Steamers - Motorized Valve P/N 856718-1 Temporarily Unavailable	Temporary Service Instructions (TSI)
Steamers Wire Insulation Pinched Under Screw Lug on Terminal Block & Contractors	Temporary Service Instructions (TSI)

PARTS TAB	
Document Title	Document Type
C24EO Series Connectionless Steamer	Parts Catalog

GENERAL

INSTALLATION, OPERATION AND CLEANING

Refer to the Installation & Operation Manual for specific instructions.

INTRODUCTION

Features

- Requires no water or drain line connections (manual fill & manual drain).
- Cast aluminum element block for efficient heat transfer and distribution.
- Field convertible to single phase or three phase power depending on the supply available.
- 3.0 gallons maximum holding pan capacity.

Steam Cooking

The C24EO series steamer provides timed or continuous mode cooking in a pressure-less compartment. The small physical size of the steamer offers an efficient way to produce many foods in small batches. Pressure-less, convection steam cooking will steam cook fresh foods or will steam defrost and cook frozen foods providing the maximum color, flavor and nutritional value with the least expenditure of energy and labor. The pressureless cooking compartment allows the operator to open and close the door, anytime during a cooking cycle.

Model Designations

- C24EO3 - 3 pan capacity
- C24EO5 - 5 pan capacity

NOTE: based on 2.5 inch pan depth

Exterior Dimensions

- C24EO3 - 24" w x 33" d x 19.5" h
- C24EO5 - 24" w x 33" d x 26" h

SPECIFICATIONS

A potable water supply does not guarantee that it's suitable for steam generation. The water supply must be within the following specifications or a local water treatment specialist may need to be consulted. If a water treatment system is installed, it must be properly maintained.

WATER REQUIREMENTS

- Hardness - Less than 3 grains (17.1ppm = 1 grain of hardness)
- Silica - Less than 13 ppm
- Total Chloride - Less than 4 ppm
- Ph range of - 7.0 to 8.0
- Un-dissolved Solids - less then 5 microns

ELECTRIC						
MODEL	TOTAL KW	AMPERAGE PER LINE				
		3 PHASE			1 PHASE	
		208 V	240V	480V	208V	240V
C24EO3	8	22.2	19.2	-	38.5	33.3
C24EO5	12	33.3	28.9	14.4	57.5	50.0
NOTES:	1. Amperage values in the table are nominal. Tolerance is +5/-10%. 2. C24EO3 - Shipped for 208V 60-50 HZ 3 phase connection. Field convertible to 240V three phase or 208/240V single phase. See wiring diagram AI2853. 3. C24EO5 - Shipped for 208V or 240V or 480V 60-50 HZ, 3 phase. 208V and 240V models are field convertible to 1 phase. See wiring diagram (LINK to AI2852).					

TOOLS

Standard

1. Standard set of hand tools.
2. VOM with minimum of NFPA-70E CATIII 600V, UL/CSA/TUV listed. Sensitivity of at least 20,000 ohms per volt. Meter leads must also be rated at CAT III 600V.
3. Clamp on type amp meter with minimum of NFPA-70E CAT III 600V,UL/CSA/TUV listed.
4. Temperature tester (thermocouple type).
5. ESD (Electrostatic discharge) Protection Kit.

Special

1. Thermal Transfer Compound, Dow Corning 340 Part No. [819643-2](#) (13.5 oz. tube) or equivalent for heating element assembly.
2. Thermal Transfer Compound, Dow Corning 340 Part No. 519504 (2 oz. tube) or equivalent for thermostats.
3. Tile Trowel 3/16" x 5/32" V notch; Grainger catalog stock number 5LG08 or equivalent for coating heating element assembly with thermal transfer compound.
4. Loctite® ODC-Free Cleaner and Degreaser (McMaster-Carr Part No. 66415A21) or equivalent fast drying, no residue cleaner.
5. Loctite® 7471™ Primer N™.
6. Loctite® 271™ or equivalent.
7. Loctite® 242™ Part No. 520228 for threads of door screws.
8. RTV 109 for securing gasket to door.
9. Lubriplate 630AA for door handle sliding bracket, 2 OZ. Part No. 00-103881-00011, 128 OZ., Part No. 00-103881-00056.

REMOVAL AND REPLACEMENT OF PARTS

COVERS AND PANELS



WARNING

Disconnect the electrical power to the machine and follow lockout / tagout procedures.

SIDE PANELS

1. Remove screws from bottom of panel.

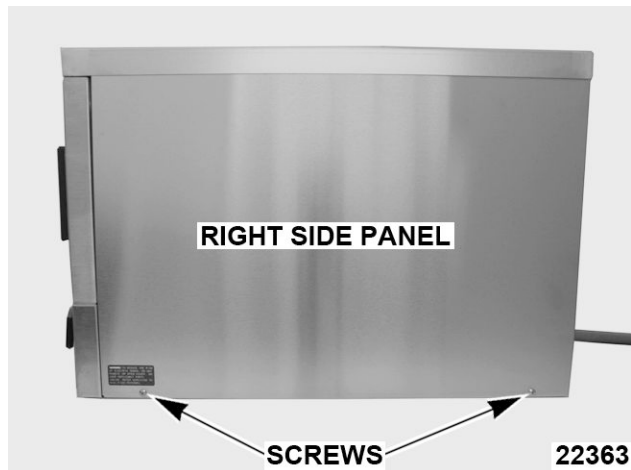

Fig. 1

2. Slide panel down to clear top cover.
3. Reverse procedure to install.

TOP COVER

1. Remove SIDE PANELS.
2. Remove screws securing rear of top cover.

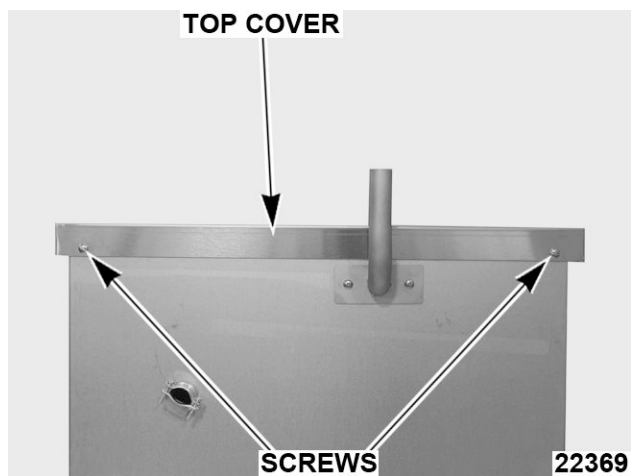

Fig. 2

3. Remove nuts securing front of top cover.

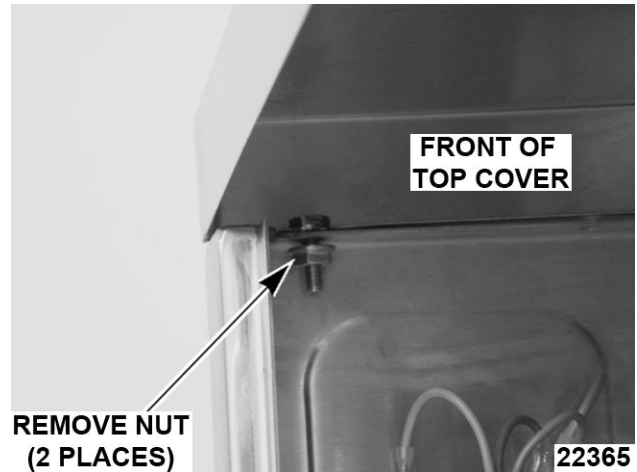

Fig. 3

4. Lift top cover off machine.
5. Reverse procedure to install.

REAR PANEL

1. Remove screws securing rear panel.

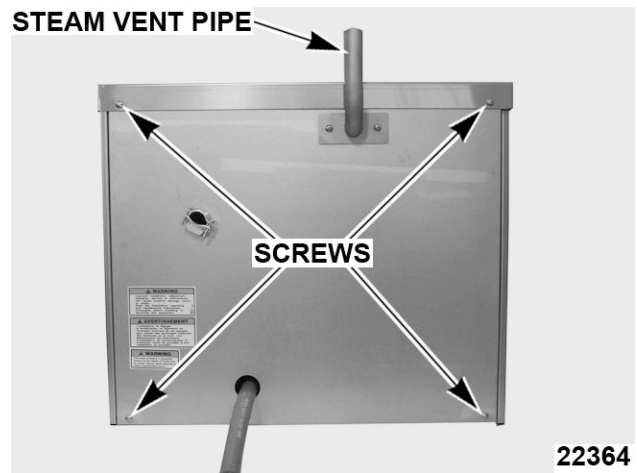

Fig. 4

2. Disconnect tube from steam vent pipe.
3. Remove rear panel.
4. Reverse procedure to install.

COMPONENT PANEL COMPONENTS



⚠ WARNING

Disconnect the electrical power to the machine and follow lockout / tagout procedures.

1. Remove right side panel as outlined under COVERS AND PANELS.
2. Disconnect lead wires to component being replaced.

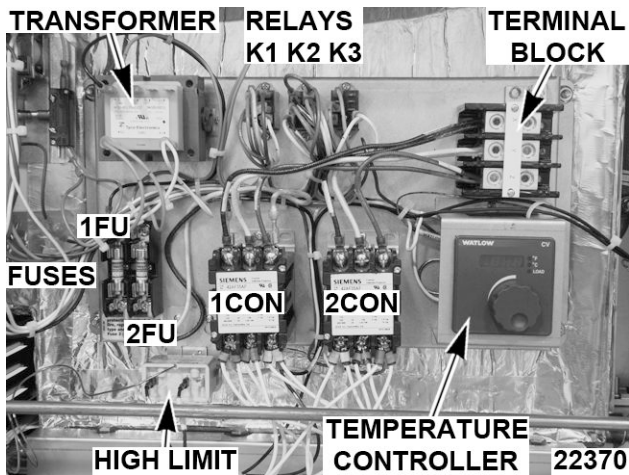

Fig. 5

3. Remove component.
4. Reverse procedure to install replacement component and check steamer for proper operation.

NOTE: If replacing temperature control, see in SERVICE PROCEDURES AND ADJUSTMENTS.

TIMER



⚠ WARNING

Disconnect the electrical power to the machine and follow lockout / tagout procedures.

1. Remove right SIDE PANEL.
2. Disconnect lead wires to timer.

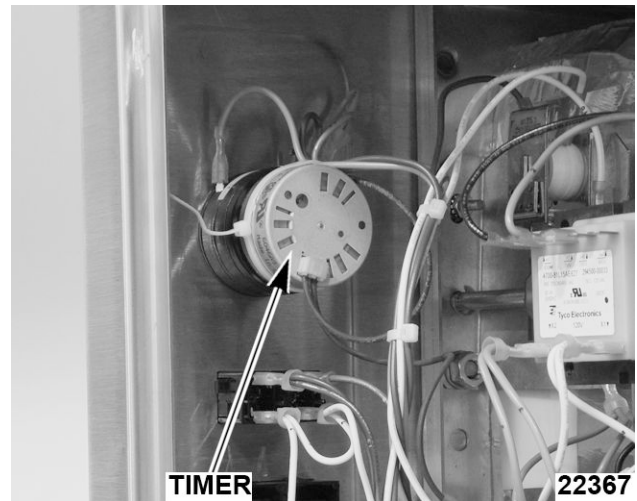

Fig. 6

3. Remove timer knob.
4. Remove rotary shaft seal from timer shaft and remove timer.

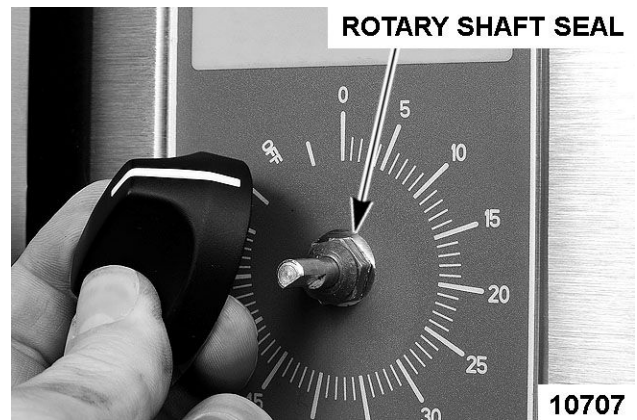

Fig. 7

5. Reverse procedure to install and check steamer for proper operation.

HOLD THERMOSTAT



⚠ WARNING

Disconnect the electrical power to the machine and follow lockout / tagout procedures.

1. Remove right SIDE PANELS.
2. Remove lead wires and mounting nuts.

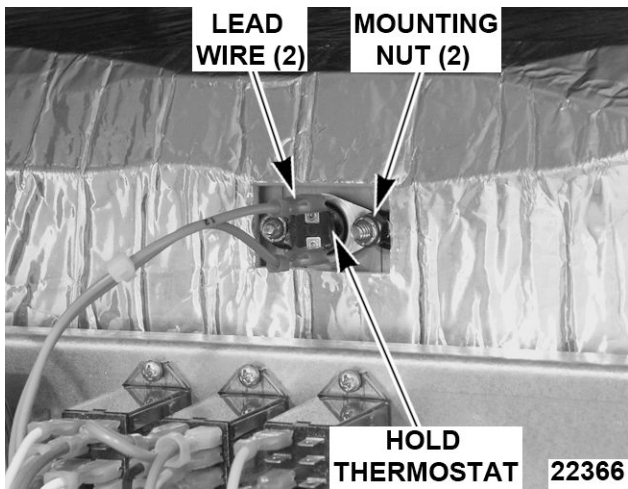

Fig. 8

3. Remove hold thermostat.
4. Apply a small amount of thermal transfer compound to the mating surface (disk side) of the replacement thermostat.
 - A. Spread the compound completely and evenly over the surface of the thermostat.
5. Reverse procedure to install and check steamer for proper operation.

HIGH LIMIT THERMOSTAT



WARNING

Disconnect the electrical power to the machine and follow lockout / tagout procedures.

NOTICE

Do not sharply bend and kink, or clamp down on the capillary tube or damage may occur.

1. Remove right SIDE PANEL.
2. Disconnect lead wires from high limit.

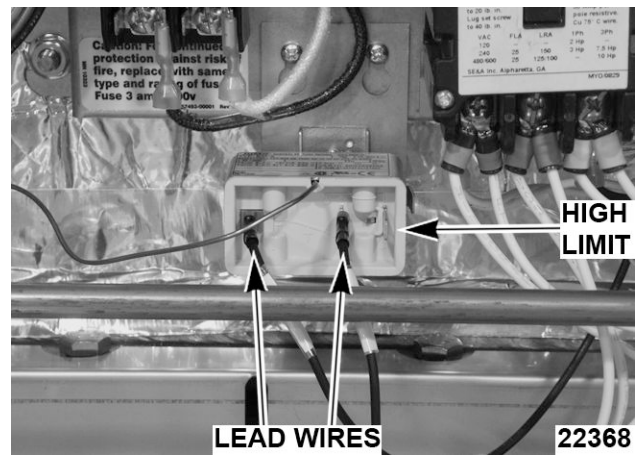

Fig. 9

3. Remove thermostat from mounting bracket.
4. Remove screw and heat shield to access capillary bulb.

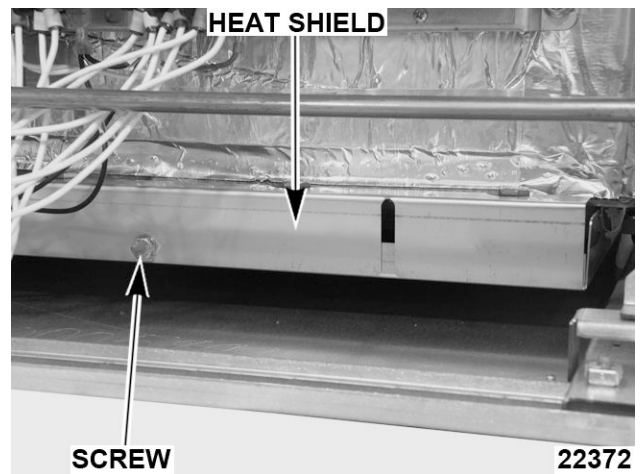

Fig. 10

5. Loosen screws securing capillary bulb.

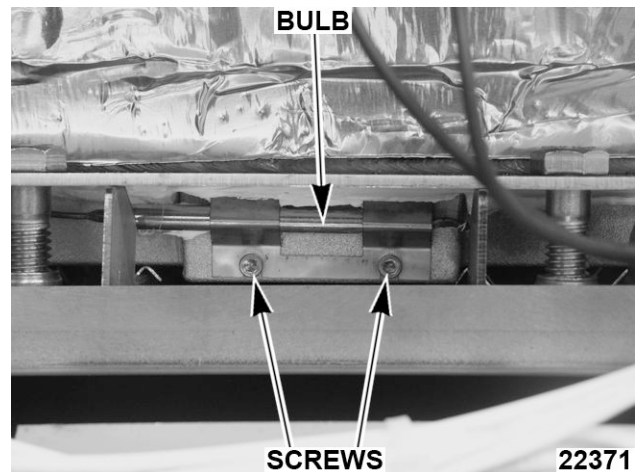

Fig. 11

6. Remove high limit thermostat.

7. Reverse procedure to install and check steamer for proper operation.
 - A. Apply a small amount of thermal transfer compound between capillary bulb and heating element assembly.

NOTE: Do not clamp bulb with excessive force.

LOW WATER THERMOSTAT



⚠ WARNING

Disconnect the electrical power to the machine and follow lockout / tagout procedures.

1. Remove right SIDE PANEL and REAR PANEL.
2. Disconnect lead wires.

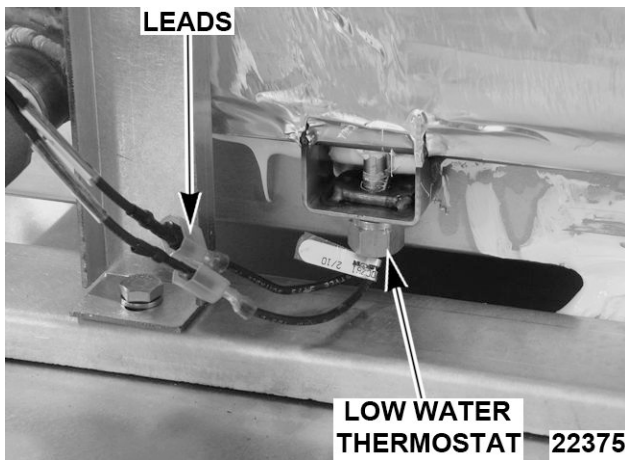

Fig. 12

3. Remove low water thermostat.
4. Reverse procedure to install and check steamer for proper operation.
 - A. Apply small amount of thermal transfer compound to tip of thermostat.
 - B. Apply Loctite 242 to threads of thermostat.
 - C. Install thermostat hand tight. **Do not over tighten.**

TEMPERATURE PROBE



⚠ WARNING

Disconnect the electrical power to the machine and follow lockout / tagout procedures.

1. Remove right SIDE PANEL and REAR PANEL.

2. Disconnect probe leads from the temperature control.

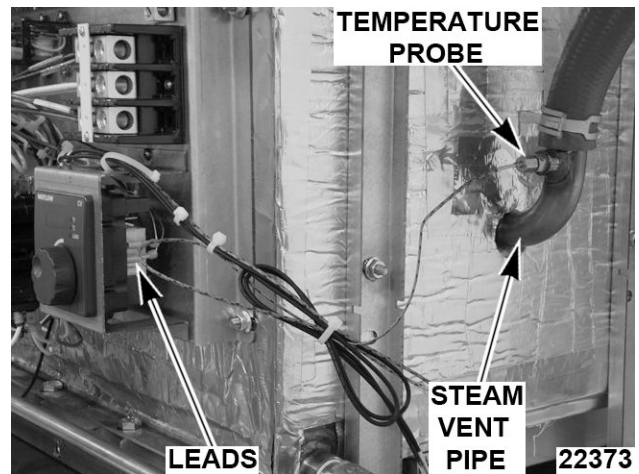

Fig. 13

3. Remove temperature probe from steam vent pipe.
4. Reverse procedure to install replacement probe and check steamer for proper operation.
5. Adjust temperature control as outlined under TEMPERATURE CONTROL CALIBRATION in SERVICE PROCEDURES AND ADJUSTMENTS.

HEATING ELEMENT ASSEMBLY - REPLACEMENT ELEMENTS



⚠ WARNING

Disconnect the electrical power to the machine and follow lockout / tagout procedures.

NOTE: The procedures below are for Threaded Stud Mounting of Heater Assembly and Spring Mounted Heater Assembly (First Production).

Serial Number Cut-Off Information

Steamers with Bolt on Heating Element Assembly

- 3 pan - Serial No. 463003581 & higher.
- 5 Pan - Serial No. 463003579 & higher.

Spring Mounted Heater Assembly

- Serial No. 463003578 and lower.

Threaded Stud Mounting of Heater Assembly

NOTE: The heater contains elements that are molded into a cast aluminum block. Block is mounted on the underside of cooking compartment using threaded mounting studs and hardware.

Heater Removal

1. Drain water from cavity.
2. Remove LEFT and RIGHT SIDE panels.
3. Remove screw and heat shield.

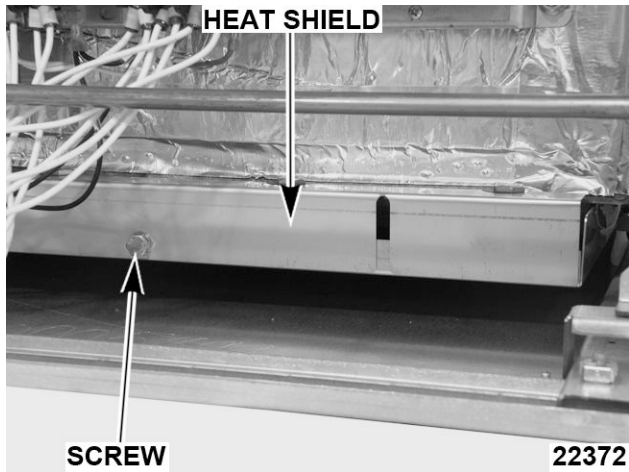

Fig. 14

4. Disconnect heating element leads from 1CON and 2CON, noting their locations.

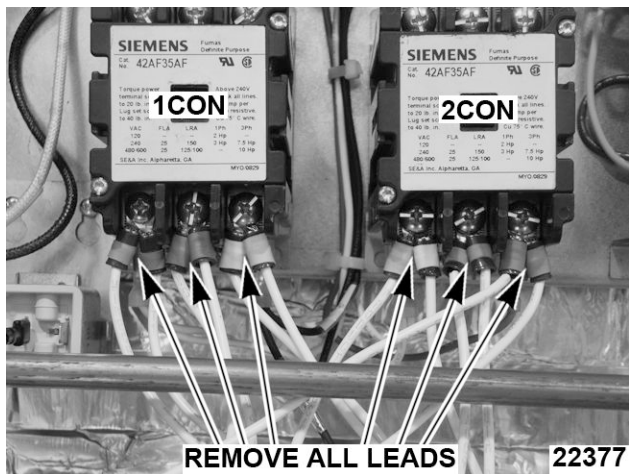

Fig. 15

5. Remove drain handle from drain lever.
6. Remove drain pivot bracket from mounting bracket on bottom panel.

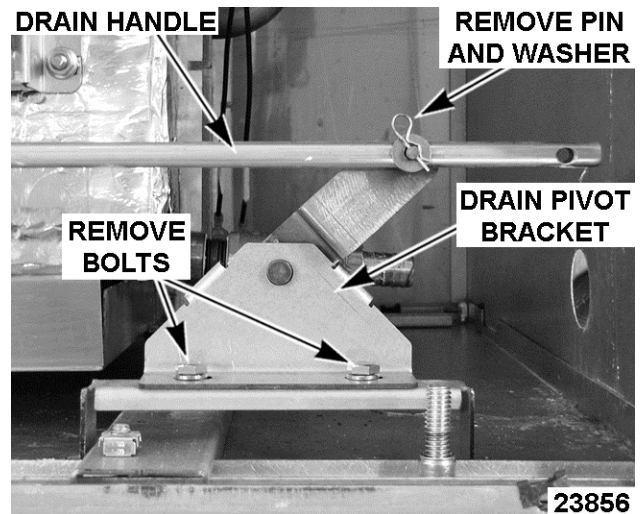

Fig. 16

7. Disconnect cavity vent hose from vent pipe.

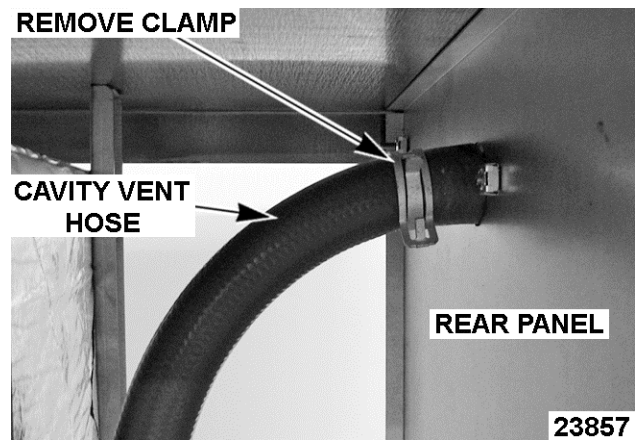

Fig. 17

8. Place steamer on its left side (non controls side).
9. Remove REAR PANEL.
10. Place a short 2x4 block under cavity for support.



Fig. 18

- Remove bolts securing support channels to bottom panel.

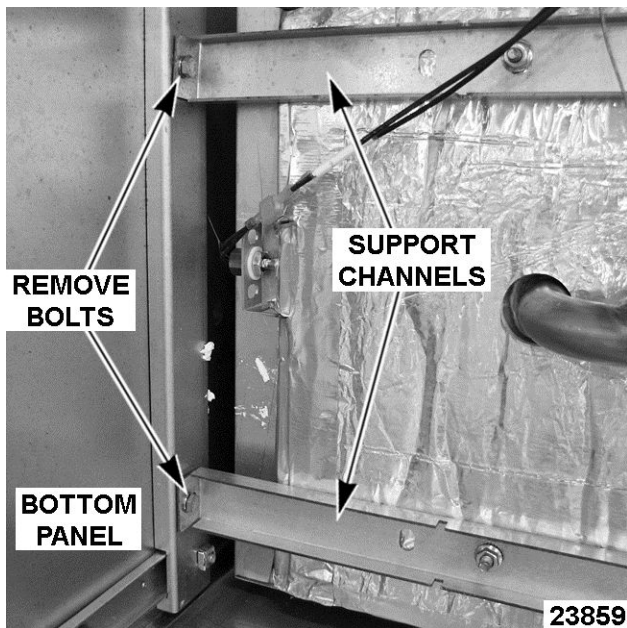

Fig. 19

- Remove left front leg and bottom panel.

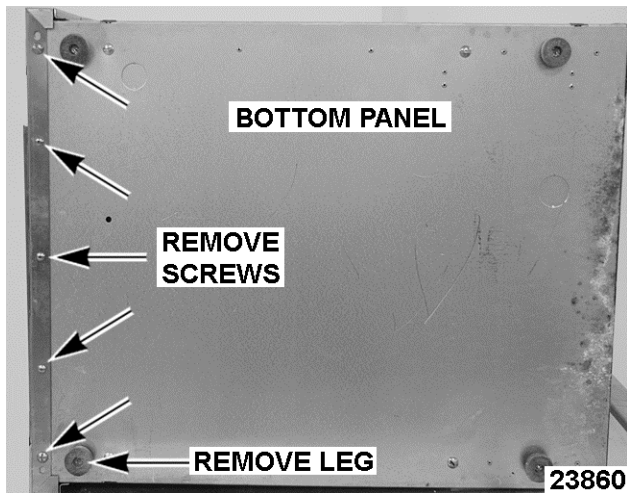

Fig. 20

- Remove heating element cover.

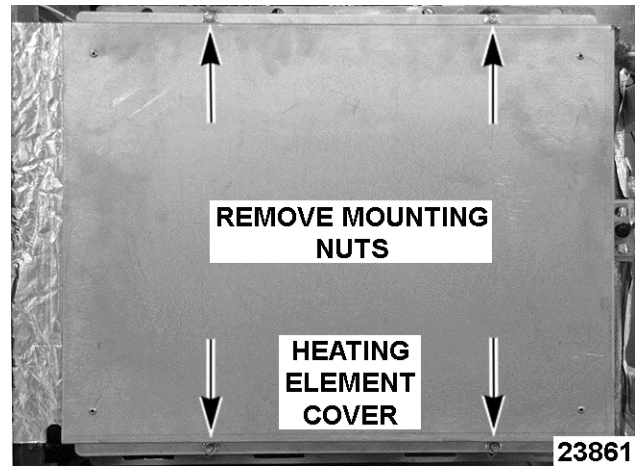

Fig. 21

- Remove heating element from steamer cavity. Refer to: HIGH LIMIT THERMOSTAT. Discard all element mounting hardware after removal.

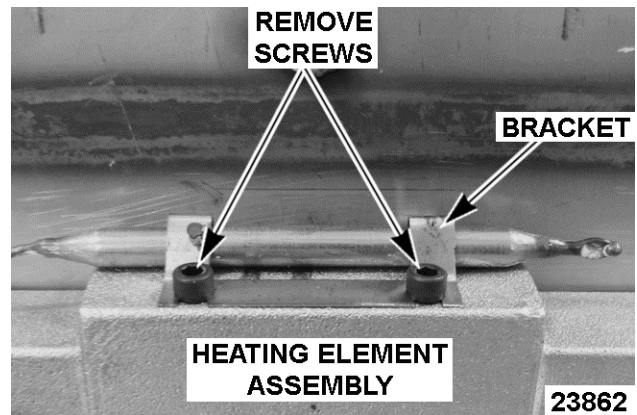

Fig. 22

Heater Installation

NOTE: When performing heater Installation for 3 pan unit with 240V supply, disconnect and insulate element leads with orange, green, and red markers (three 664W elements not used).

NOTE: Scrape off as much of the old thermal transfer compound from underside of cooking compartment as possible before installing replacement heater element.

- Completely and evenly coat contact face of heating element assembly with thermal transfer compound using notched trowel. Use approximately one 13.5 oz. tube of thermal transfer compound to cover the surface.



Fig. 23

2. Install heating element assembly onto bottom of cavity.
3. Place fender washer and loading spring (belleville) over each mounting stud. Thread brass nut onto stud but hand tighten only.

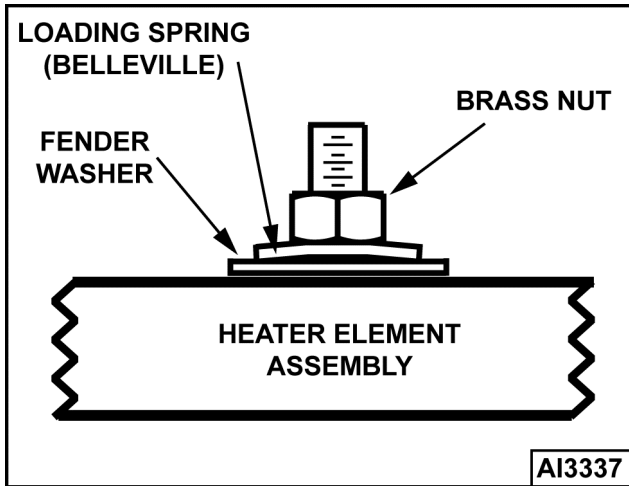

Fig. 24

4. Torque each mounting nut in sequence shown below to 48-52 in-lbs.

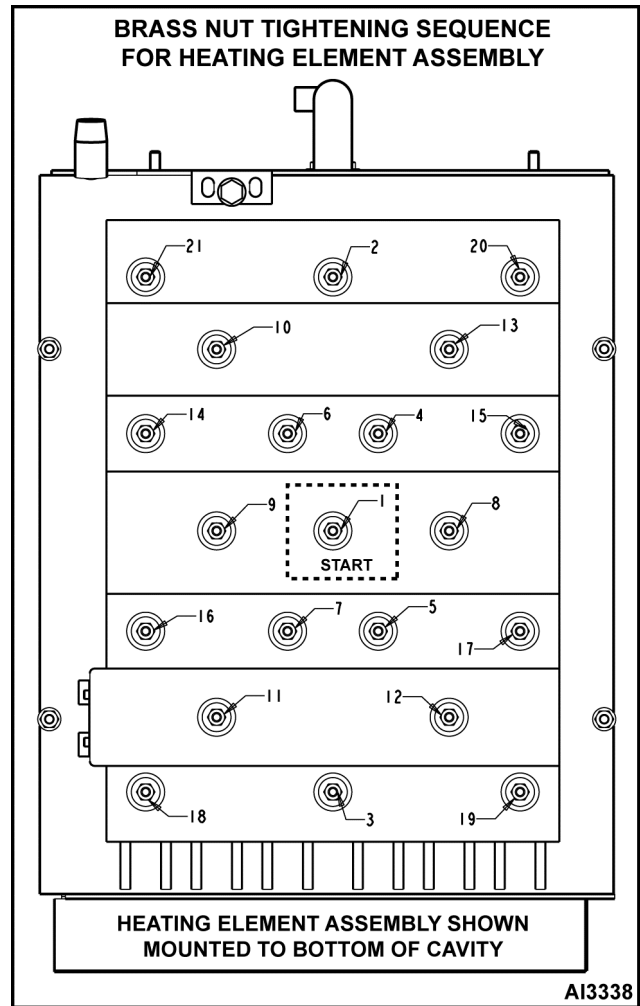

Fig. 25

5. Apply thermal transfer compound between high limit bulb and heating element assembly.
6. Mount high limit thermostat bulb to element assembly.
7. Install heating element cover.
8. Install bottom panel and left leg
9. Install support channels to bottom panel.
10. Install drain pivot bracket to bottom panel.
11. Install drain handle to drain lever.
12. Remove 2x4 block under the cavity.
13. Install rear panel.
14. Connect hose from vent pipe.
15. Place steamer on its legs.
16. Connect lead wires to 1CON and 2CON in noted positions.
17. Install left and right side panels.
18. Check steamer for proper operation.

SPRING MOUNTED HEATER ASSEMBLY (First Production)

The heater contains elements that are molded into a cast aluminum block. The springs compress to hold block tight to bottom surface of compartment but allow for thermal expansion and contraction.

Heater Removal

1. Remove right side panel on steamer.
2. Remove screw and heat shield.

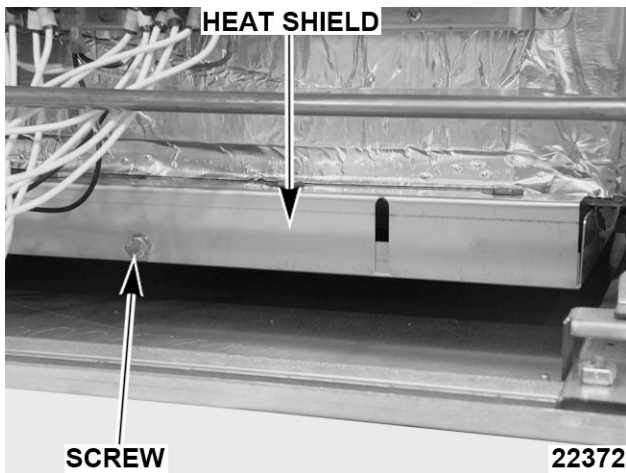

Fig. 26

3. Remove bolts.

NOTE: Support heater element block while removing last bolt. Heat shield assembly (tray) is hinged on opposite side and will tilt down after the last bolt is removed.

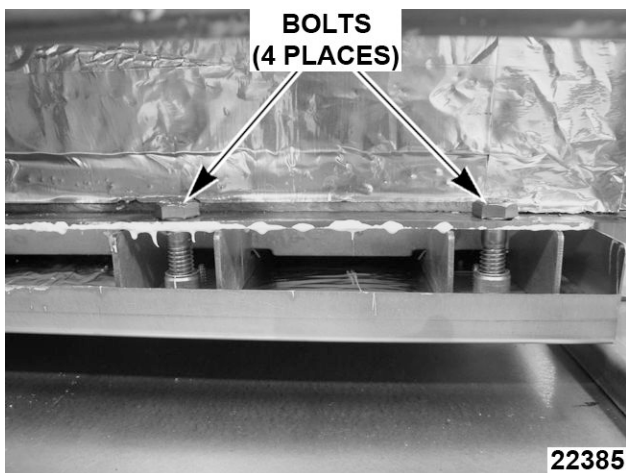

Fig. 27

4. Disconnect heating element leads from 1CON and 2CON, noting their locations.

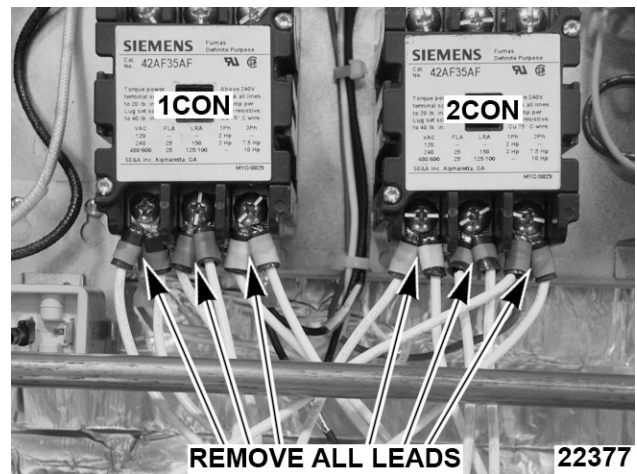

Fig. 28

5. Partially remove heater block from heat shield assembly (tray) by pulling assembly towards you.
6. Remove high limit thermostat bulb and bracket.

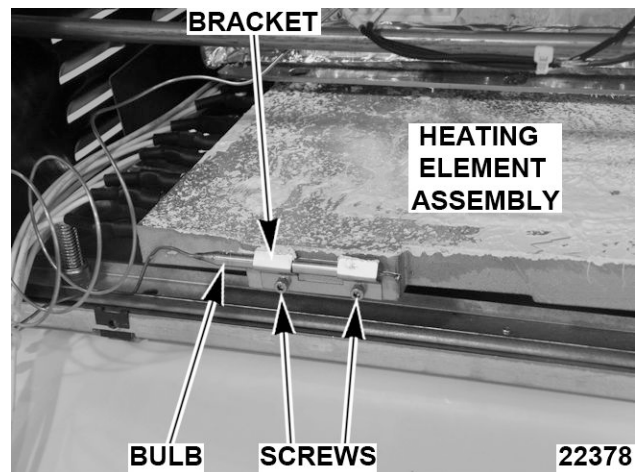

Fig. 29

7. Remove heater element block from steamer.

Heater Installation

NOTE: When performing heater Installation for 3 pan unit with 240V supply, disconnect and insulate element leads with orange, green, and red markers (three 664W elements not used).

NOTE: Scrape off as much of the old thermal transfer compound from underside of cooking compartment as possible before installing replacement heater element.

1. Completely and evenly coat contact face of the replacement heater element block with heat sink compound using notched trowel. Use approximately one 13.5 oz. tube of thermal transfer compound to cover the surface.

2. Slide heater element block partially into heat shield assembly (tray), leaving enough space to mount high limit bulb.
 - A. Apply heat sink compound between high limit bulb and heater element block.
 - B. Secure high limit thermostat bulb to the heater element block.
3. Slide heater block in until it stops then push toward front of machine.
 - A. Raise heat shield assembly (tray) and install mounting bolts to secure. Hand tighten only.
 - B. Tighten one of the inner bolts several turns then move to other inner bolt. Continue tightening all 4 bolts in an alternating pattern until top of each heat mount strap contacts bottom of cooking compartment flange.

NOTICE

Do not over tighten bolts or damage to heat mount strap may occur.

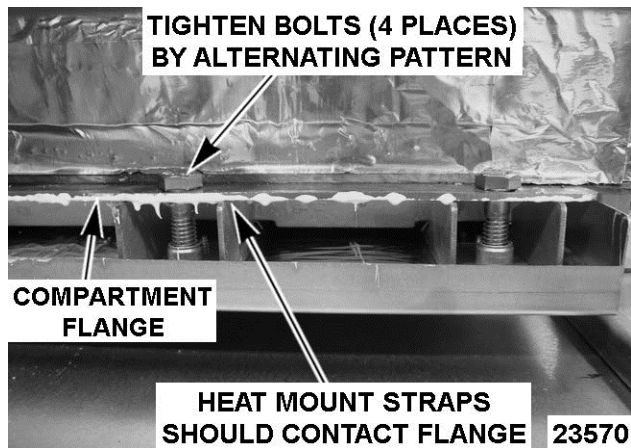

Fig. 30

- C. Ensure heat sink compound does not flow onto low water thermostat (sensor) at rear of compartment. If it does, remove excess.
4. Connect lead wires to 1CON and 2CON in noted positions. Tighten screws to secure wires.
5. Install heat shield.
6. Check steamer for proper operation.

MANUAL DRAIN VALVE



WARNING

Disconnect the electrical power to the machine and follow lockout / tagout procedures.

1. Remove right SIDE PANEL and REAR PANEL.
2. Remove pin and washer to disconnect the handle linkage from linkage bracket.

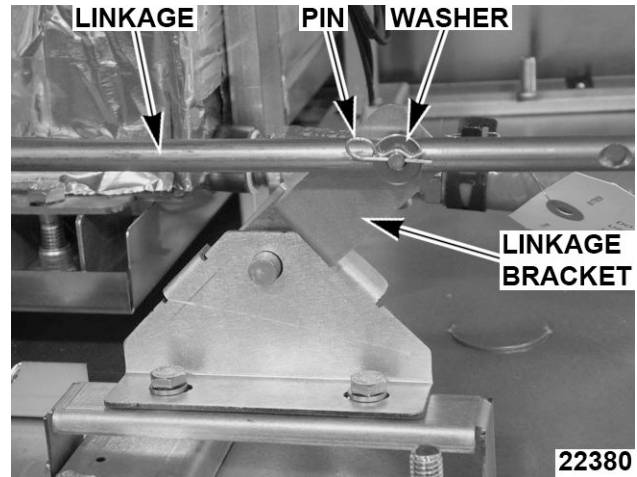

Fig. 31

3. Remove nut and linkage bracket.

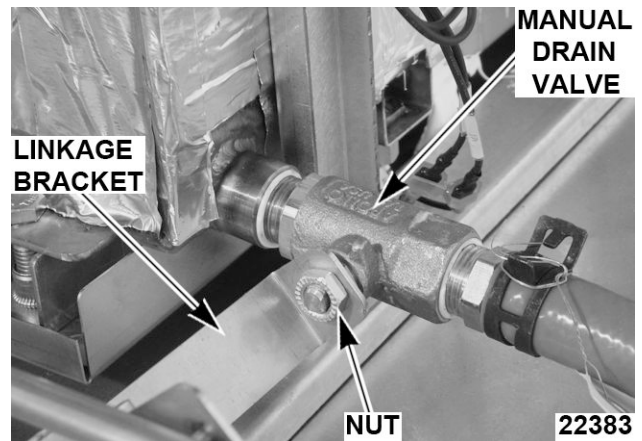

Fig. 32

4. Remove drain valve.
5. Reassemble parts removed in reverse order of removal.
 - A. Apply pipe thread sealant to plumbing threads before assembly.
6. Check steamer for leaks and proper operation.

DOOR



⚠ WARNING

Disconnect the electrical power to the machine and follow lockout / tagout procedures.

1. Close door.
2. Remove left SIDE PANEL.
3. Remove nuts from upper hinge located inside front panel.

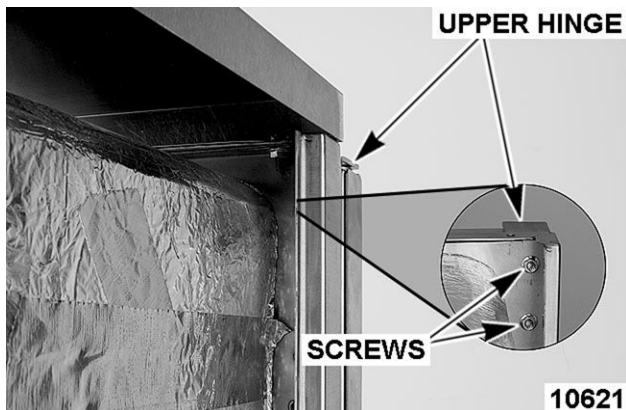

Fig. 33

4. Open door slightly, and while holding door, pull upper hinge away from front panel.
5. Pull upper hinge out of upper door hinge bushing.
6. Lift door assembly up and off lower door hinge.
7. Reinstall parts removed in reverse order of removal.
8. Check door for fit and proper sealing of gasket.

DOOR GASKET



⚠ WARNING

Disconnect the electrical power to the machine and follow lockout / tagout procedures.

1. Open door.
2. Remove the shoulder screws and pan pusher bracket from gasket plate.

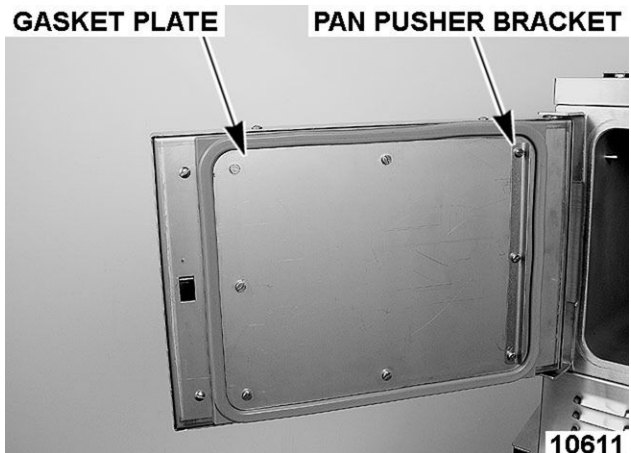

Fig. 34

3. Remove gasket plate.
4. Remove gasket from inner door panel.
5. Remove RTV from bottom part of inner door panel. Apply new RTV 109 to bottom of door where shown when assembling gasket to door.

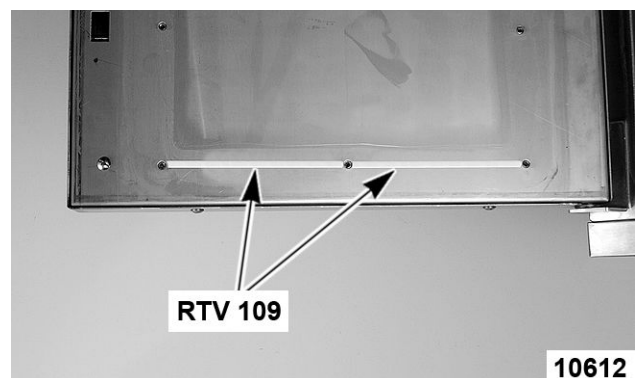

Fig. 35

6. Place a small amount of RTV109 into the inner door panel gasket screw holes before assembly.
7. Position the new gasket on gasket plate and reverse procedure to install.

DOOR HANDLE



⚠ WARNING

Disconnect the electrical power to the machine and follow lockout / tagout procedures.

REMOVAL

1. Open door.
2. Remove screws from top and bottom of door assembly.



Fig. 36

3. Pull outer door housing away from inner door panel starting at the hinge side of door to separate the door halves.

NOTE: The smaller radius of the step spacers fit into the slots of the outer door housing and is used to provide clearance for handle operation.

4. Remove lock nuts and stepped spacers from threaded studs of door handle.

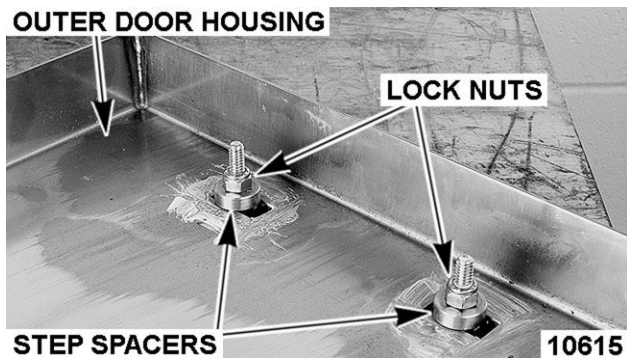

Fig. 37

INSTALLATION

1. Apply Lubriplate 630AA around slots of outer door housing where step spacers contact housing.
2. Install door handle into outer door housing such that hinge side of door housing is to the left and arrow on handle is pointed upward.
3. Install step spacer with smaller radius toward handle and door housing. Smaller radius is a slip fit with outer door housing slot.

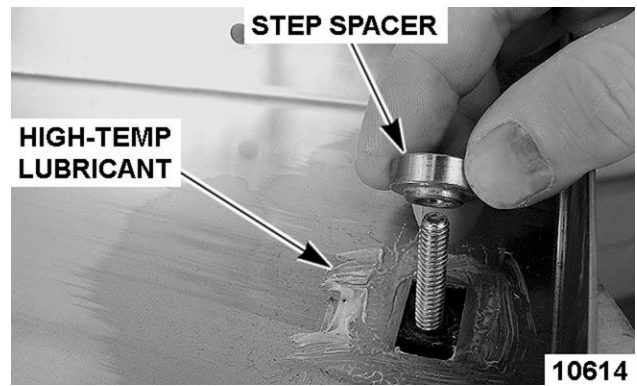

Fig. 38

4. Install lock nuts and tighten until no gap exists between handle, step spacer and lock nut. Do not over-tighten lock nuts.
5. Close inner door panel so that latch mechanism engages striker on front panel.
6. Install outer door housing onto inner door panel.
7. Align the top and bottom screw holes of outer door housing with inner door panel.

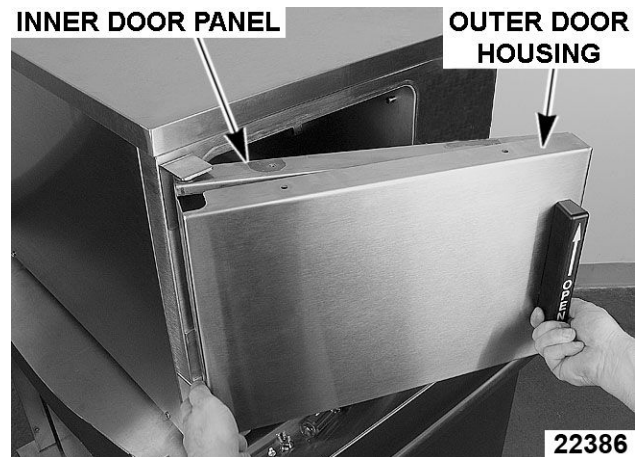

Fig. 39

8. Apply Loctite 7471 Primer N and Loctite 242 to threads of screws before assembling.
9. Install screws to secure door halves together.
10. Check opening and closing operation of door.

DOOR LATCH ASSEMBLY



WARNING

Disconnect the electrical power to the machine and follow lockout / tagout procedures.

REMOVAL AND DISASSEMBLY

1. Separate outer door housing assembly from inner door panel as outlined under DOOR HANDLE.
2. Remove screws securing latch assembly to inner door panel and remove latch mechanism.

LATCH MECHANISM SCREWS

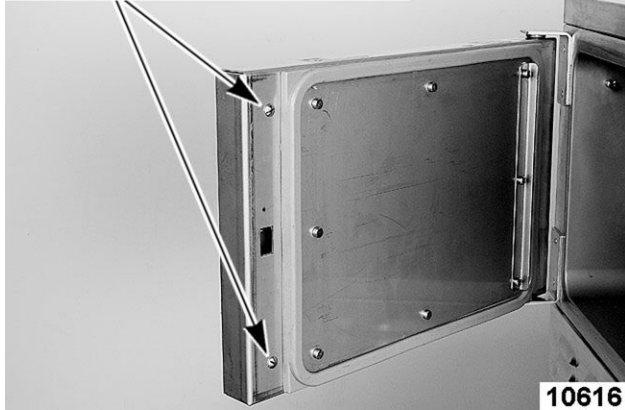

Fig. 40

3. Remove E-clip from latch assembly pins and pull pins from latch mechanism.

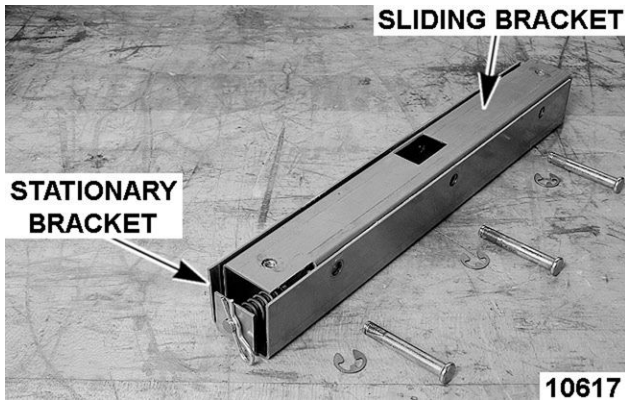

Fig. 41

4. Remove retaining pin from spring pin.
5. Separate sliding bracket from stationary bracket.

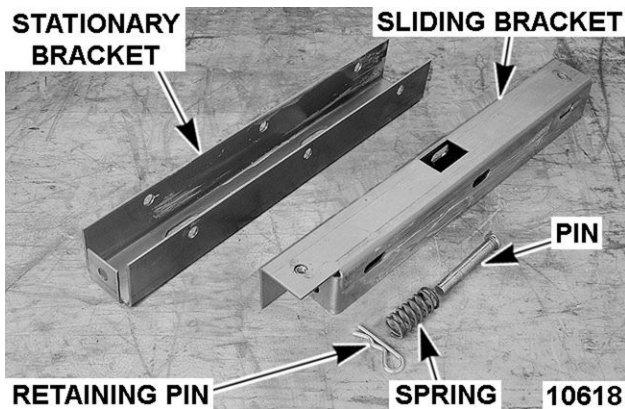

Fig. 42

ASSEMBLY

1. Apply Lubriplate 630AA to sides of sliding bracket.
2. Insert spring pin into bottom of sliding bracket.
 - A. Place spring over spring pin.
3. Assemble sliding bracket into stationary bracket.
4. While holding head of spring pin against bottom of sliding bracket, insert spring pin into keeper hole in bottom of stationary bracket.

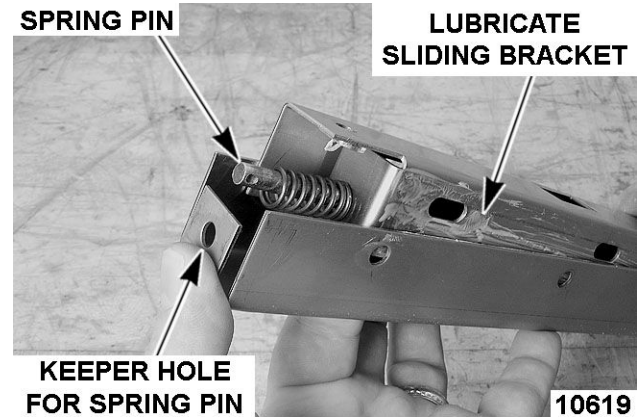

Fig. 43

- A. Secure spring pin in place with retaining pin.

NOTE: Install pins such that heads of pins will be facing inward toward hinge side of inner door panel when latch assembly is installed.

5. Install pins to assemble stationary and sliding brackets together.
 - A. Secure pins into position with E-clip.

INSTALLATION

1. Install latch assembly onto inner door panel with spring pin toward bottom of door panel.
 - A. Apply Loctite 271 to threads of screws before assembly and secure latch assembly to inner door panel.

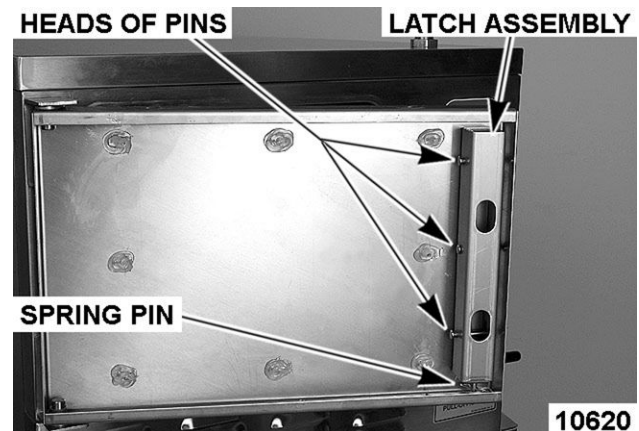

Fig. 44

2. Install outer door housing assembly as outlined in DOOR HANDLE INSTALLATION.
3. Check opening and closing operation of door.
4. Check steamer for proper operation and leaks around door seal.

DOOR HINGE BEARINGS



⚠ WARNING

Disconnect the electrical power to the machine and follow lockout / tagout procedures.

1. Close door.
2. Remove left side panel, see COVERS AND PANELS.
3. Remove nuts from upper hinge located inside front panel.

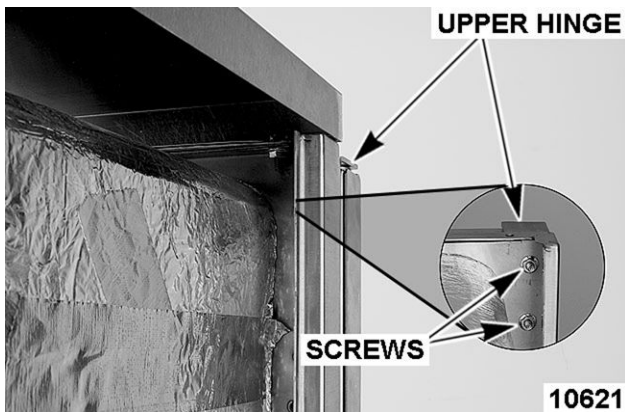

Fig. 45

4. Open door slightly, and while holding door, pull upper hinge away from front panel.
5. Pull upper hinge out of upper door hinge bearing.
6. Lift door assembly up and off lower door hinge.
7. Pry hinge bearing out from door assembly.
8. Remove outer door housing.

NOTICE

Do not drive bearing into place. The inner door panel could be damaged. Press bearing into position.

NOTE: When replacing door hinge bearings, replace both hinge bearings.

9. Position replacement hinge bearing over hinge opening in door assembly.



Fig. 46

- A. Press hinge bearing fully into door assembly using a C-clamp or equivalent.
10. Reassemble parts removed in reverse order.
11. Check door for fit and proper door gasket sealing.

REMOVAL AND REPLACEMENT (AUTOFILL OPTIONAL)

PROBES



WARNING

Disconnect the electrical power to the machine and follow lockout / tagout procedures.

1. Shut off electric and water supply.
2. Remove RIGHT SIDE PANEL to access probes behind steamer cavity.
3. Remove nuts (1, Fig. 47) holding wire terminals on probes.

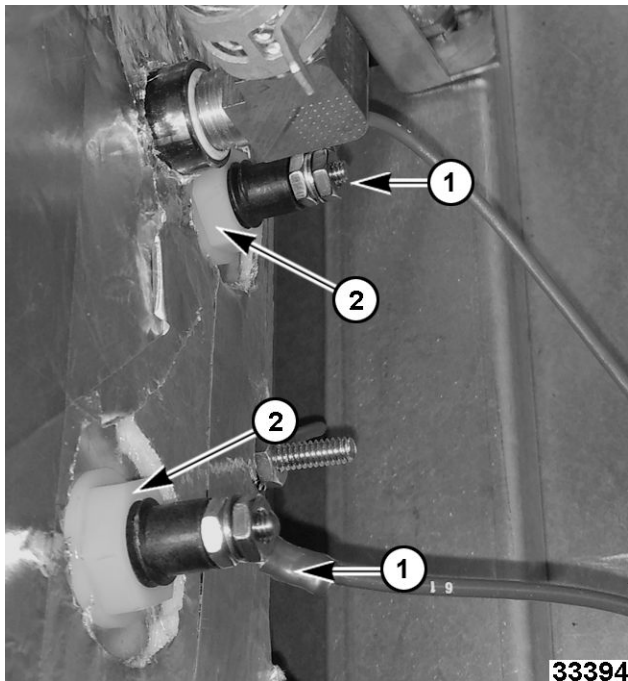

Fig. 47

4. Remove nylon nut (2, Fig. 47) on back of probe.
5. Remove probe from inside steamer cavity.

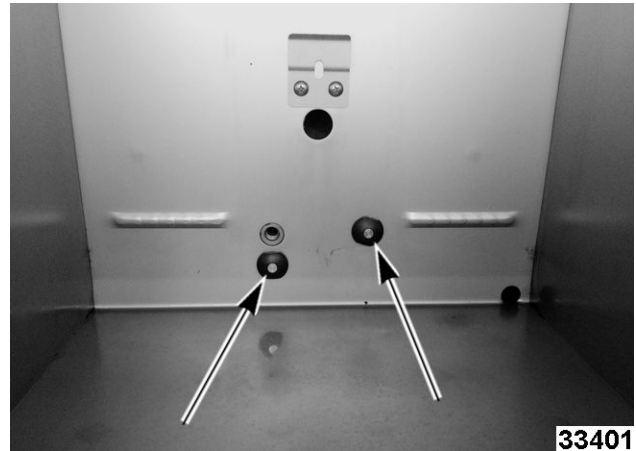

Fig. 48

NOTICE

Verify O-ring (1, Fig. 49) is seated and not damaged.

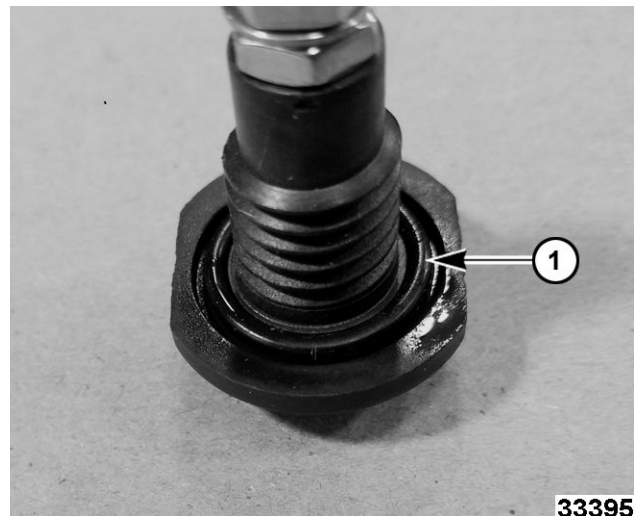

Fig. 49

6. Reverse procedure to install.

NOTICE

Use a back-up wrench (Fig. 50) to keep internal probe components from twisting when reinstalling.

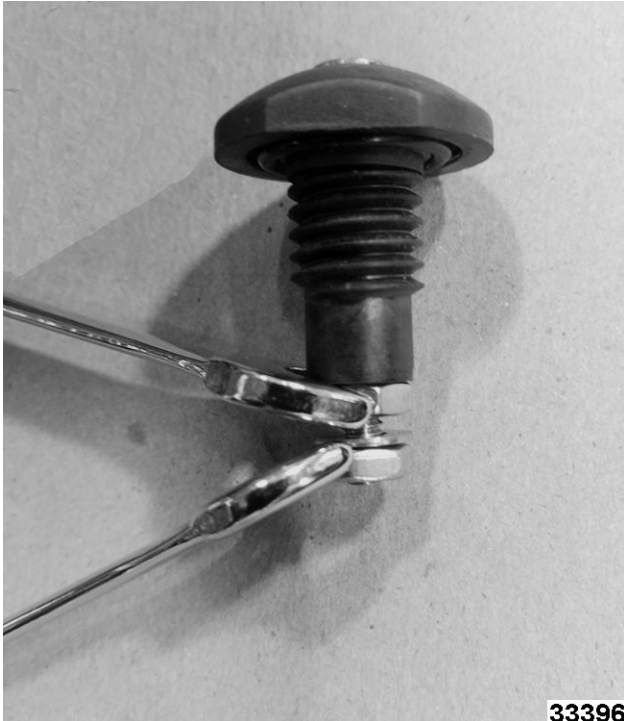

Fig. 50

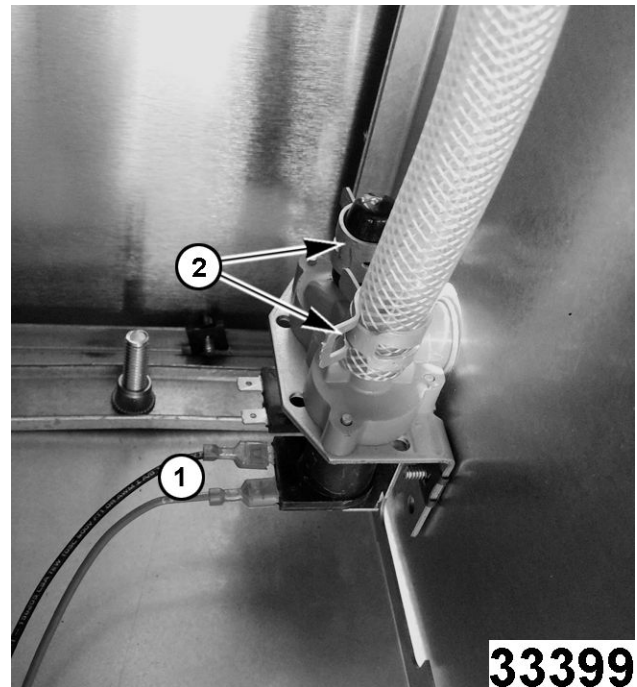

Fig. 51

4. Disconnect hose and cap clamps (2, Fig. 51) from outlet ports.
5. Remove solenoid mounting screws from back of unit.

NOTICE

Do not overtighten nylon nut.

SOLENOID VALVES



WARNING

Disconnect the electrical power to the machine and follow lockout / tagout procedures.

1. Shut off electric and water supply.
2. Remove LEFT SIDE PANEL.

NOTE: If left side is not accessible, solenoid valves can be accessed through the right side.

3. Note and disconnect wires (1, Fig. 51).

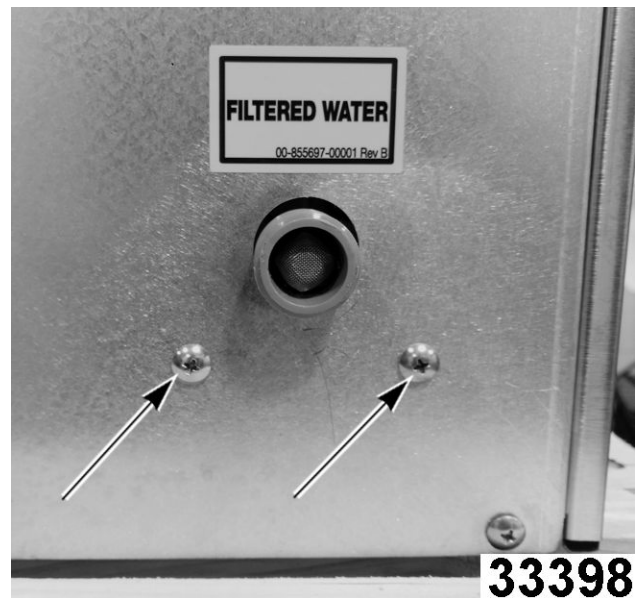

Fig. 52

6. Reverse procedure to install.
7. Use new clamps when installing cap and hose on outlet ports.

NOTICE

Apply two to three wraps of electrical tape on valve where the hose clamp seats during installation to help prevent leaks.

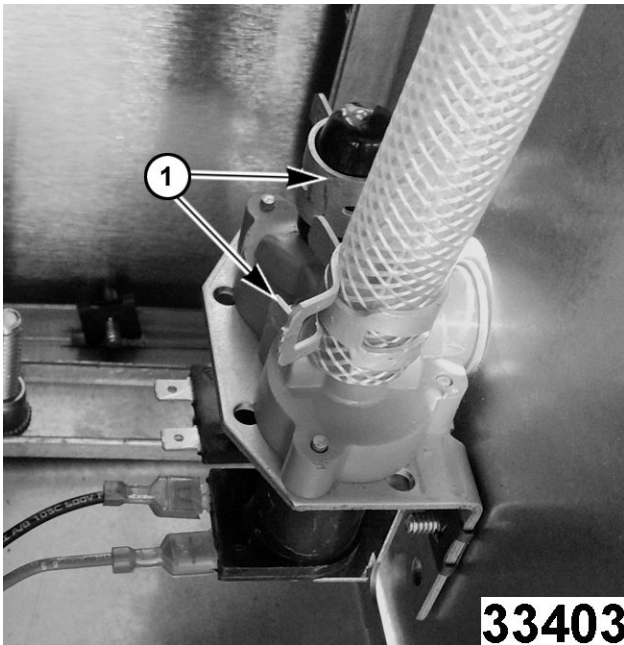

Fig. 53

NOTICE

Verify cap and clamp are installed on outlet port not being used.

WATER LEVEL ALARM



WARNING

Disconnect the electrical power to the machine and follow lockout / tagout procedures.

1. Shut off electric and water supply.
2. Remove RIGHT SIDE PANEL.
3. Remove knurled knob (1, Fig. 54).

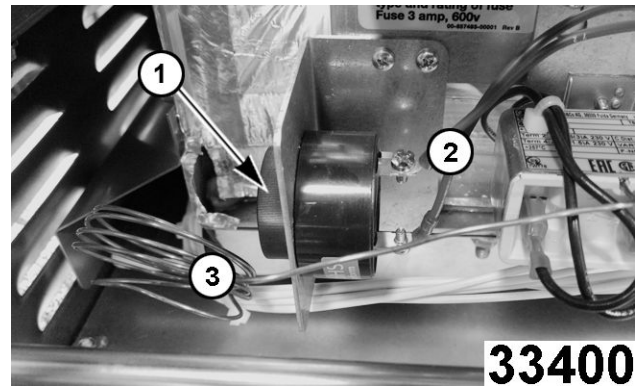

Fig. 54

4. Note and disconnect wiring (2, Fig. 54).

NOTICE

Take care not bend capillary tube (3, Fig. 54).

5. Reverse procedure to install.

AUTOFILL CONTROL ASSEMBLY



WARNING

Disconnect the electrical power to the machine and follow lockout / tagout procedures.

Components on the Autofill control assembly are:

- Transformer. (1, Fig. 55)
- Low Water Control Board. (2, Fig. 55)
- Time Delay Relay. (3, Fig. 55)
- Relay Switches. (4, Fig. 55)

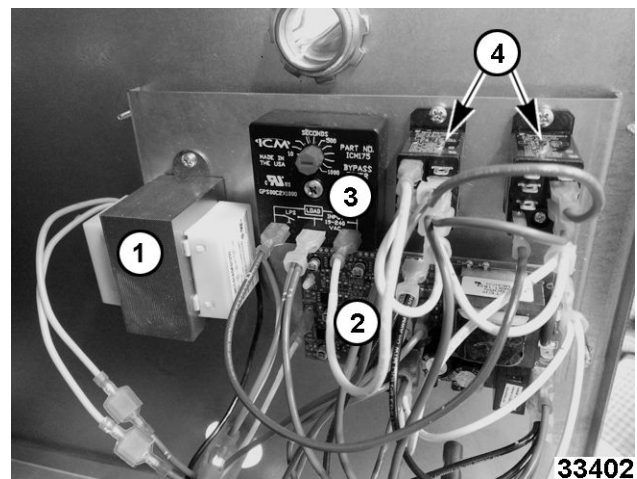

Fig. 55

1. Shut off electric and water supply.
2. Remove RIGHT SIDE PANEL.

3. Note and disconnect wiring from component being replaced.
4. Remove component mounting screws.
5. Reverse procedure to install.

NOTICE

When replacing time delay relay, verify seconds are set at 10 seconds (1, Fig. 56).



Fig. 56

SERVICE PROCEDURES AND ADJUSTMENTS

⚠ WARNING

Certain procedures in this section require electrical test or measurements while power is applied to the machine. Exercise extreme caution at all times. If test points are not easily accessible, disconnect power and follow lockout / tagout procedures, attach test equipment and reapply power to the test.

DOOR LATCH ADJUSTMENT

Opening a Jammed Door

NOTICE

Should the steamer door jam and cannot be opened, **DO NOT FORCE OR PRY** the door as damage will occur.

1. Lift up on bottom of door at the handle end to disengage latch.
 - A. If door does not open, remove right side panel, see [COVERS AND PANELS](#) .
 - B. Locate the striker that catches on door latch near steam chamber on front panel.

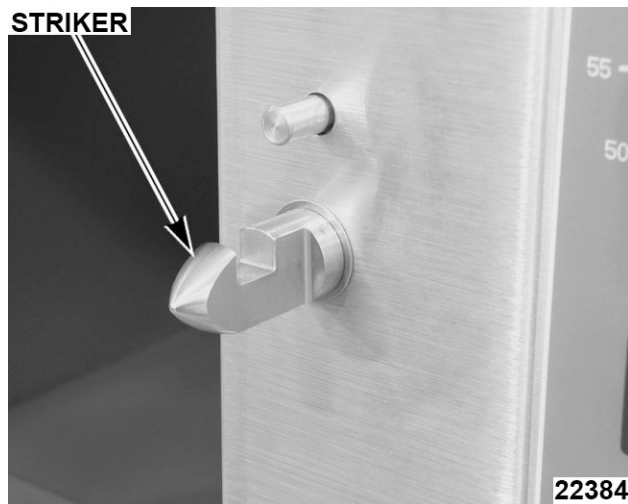

Fig. 57

- C. Remove nut from striker and this should release it from the panel.



Fig. 58

- D. Open door.
2. Remove striker.
3. Remove any burrs on striker that may cause latch to stick.
4. Apply Loctite 271 to threads of striker.
5. Reinstall striker with slotted side up. Snug striker nut. Perform Adjustment, so door will not jam.

Adjustment

1. Reinstall striker with slot pointing upward and hand tighten nut.
2. Close door to center striker in front panel mounting hole.
3. Open door and check striker slot for horizontal alignment. The slot on striker must be kept horizontal in order for door latch to catch properly and latch.
4. Once proper slot alignment has been set, hold striker close to its base then tighten the striker nut. Be careful not to damage striker slot when tightening or door may not latch properly.

NOTE: Do not over-tighten nut. If over-tightened, striker may turn and change alignment.

NOTE: If door does not open easily, add shims between striker and cabinet front. When adding shims make certain that door gasket seals properly and

steamer does not leak. Remove shims as necessary until leaking stops.

HEATING ELEMENT TEST

The heating element assembly contains elements molded into a cast aluminum block. 3 pan units have 6 elements and 5 pan units have 3 elements. See wiring diagrams.

1. Turn cooking mode switch to constant.
2. Measure voltage at heating element terminals on contactors and verify it against data plate voltage.

NOTE: For 480V units, element voltage is 277V.

- A. If voltage is incorrect, find the source of the problem.
- B. If voltage is correct, check current draw (amps) through the heating element lead wires.

NOTE: This method is preferred over a resistance check when a clamp on type amp meter is available.

- 1) If current draw is correct then heating element is functioning properly. See table below for proper values.
- 2) If current draw is not correct, turn cooking mode switch to OFF and disconnect the electrical supply.
 - a. Replace heating element assembly then proceed to step 3.
- C. If unable to check current draw, a resistance check may indicate a malfunctioning element.
 - 1) Turn the cooking mode switch to OFF and disconnect the electrical supply.
 - 2) Remove the lead wires from the heating element and check resistance (ohms). See table below for proper values
3. Check for proper operation.

MODEL	VOLTS	WATTS PER ELEMENT	AMPS PER ELEMENT LEAD	OHMS PER ELEMENT
C24EO3	208	2003	9.6	21.6
	208	664	3.2	65.2
	240	2667	11.1	21.6
C24EO5	208	4000	19.2	10.8
	240	4000	16.7	14.4
	480	4000	14.4	19.2
NOTES:	1. Values in the table are nominal. Tolerance is +5/-10%. 2. 3 pan 208V units use three 2003W elements and three 664W elements. 3. 3 pan 208/240V units share the same element assembly block. 240V units use only the three 2003W-marked elements (2667W actual). 4. Resistance values			

TEMPERATURE CONTROL CALIBRATION

To set temperature control for optimum steamer operation, the elevation above sea level for service location must first be determined. The steamer was preset at factory to sea level.

The elevation is used in conjunction with elevation table below, to determine correct set point temperature for the control.

NOTE: If set point temperature is too high, the excess boiling action will cause water droplets to exit the steam vent pipe, and cause high water usage.

1. Remove right side panel, see COVERS AND PANELS.
2. Place a thermocouple approximately one inch down in the center of steam vent pipe.
3. Turn steamer on by selecting constant mode.
4. Allow steamer temperature to stabilize by completing two heating cycles.

5. Record the temperature reading when regulating contactor opens.
6. Using the elevation table, compare the recorded temperature to the temperature listed for the specific elevation.

NOTE: Use temperature scale on control dial plate for reference only. The scale represents dial turns in 1°F increments, not the actual temperature. When calibrating, use the recorded temperature taken from thermocouple.

ELEVATION (FT)	TEMPERATURE (°F)
Sea Level	210
1,000	208
2,000	206
3,000	204
4,000	202
5,000	200
6,000	198
7,000	196
8,000	195
9,000 or above	194

- A. If the set point temperature of the control is correct, no adjustment is necessary.
- B. If the set point temperature of the control is not correct, adjust the temperature control.
 - 1) Turn temperature control dial **clockwise** to increase temperature or **counterclockwise** to decrease temperature.

NOTE: During temperature control adjustment, display will blink on/off. When display reverts to a steady image, that displayed temperature set point has been "locked in" to memory.

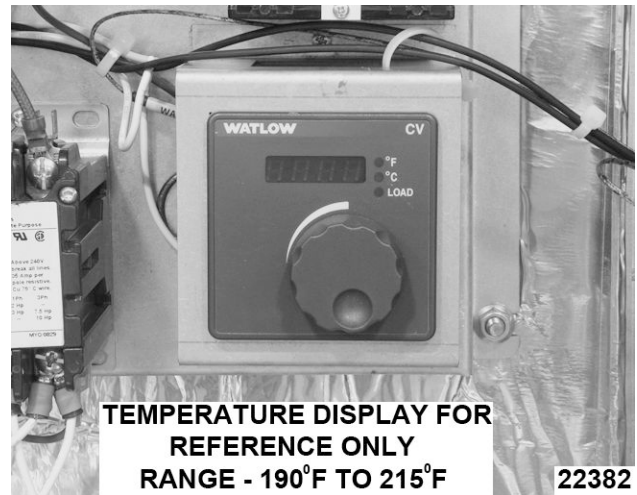

TEMPERATURE DISPLAY FOR REFERENCE ONLY RANGE - 190°F TO 215°F

22382

Fig. 59

ELECTRICAL OPERATION

COMPONENT FUNCTION

Buzzer	Creates audible signal when timed cook cycle is complete and when a low water condition exists.
Limiting Contactor (1CON)	Supplies line voltage to heating element assembly. Energized whenever Power Switch (1S) is on and High Limit Thermostat (1TAS) and Low Water Thermostat (2TAS) are closed.
Regulating Contactor (2CON)	Supplies line voltage to heating element assembly. Energized whenever Hold Thermostat (3TAS) is closed or the temperature controller calls for heat.
Heating Element	Located below water reservoir. Heats water to produce steam.
Fuses (1FU & 2FU)	Protect control circuitry from over-currents.
Low Water Light (1LT)	Amber (AM) colored light. Lit when Low Water Thermostat (2TAS) senses water level is too low inside steamer.
On Light (2LT)	Amber (AM) colored light. Lit when Power Switch (1S) is on.
Cook Light (3LT)	Red (RD) colored light. Lit when High Limit (1TAS) and Low Water (2TAS) thermostats are closed, door is closed and timer is set.
Relay (K1)	Controls Regulating Contactor (2CON) based on input from Hold Thermostat (3TAS) and Temperature Controller. Does not allow Timer Motor to run while Hold Thermostat (3TAS) is closed.
Relay (K2)	Latches Power Switch (1S) circuit. Turns on Low Water Light (1LT) and Buzzer when steamer is low on water.
Relay (K3)	Controlled by Power Switch (1S). Keeps Buzzer from sounding and Low Water Light (1LT) off when switch is in off position.
Power Switch (1S)	Rocker switch that turns steamer OFF and ON (momentary on). Switch also resets Low Water Light (1LT) and Buzzer.
Door Switch (1SW)	Removes power from a portion of the steamer control circuit when door is opened.
High Limit Thermostat (1TAS)	Protects steamer by removing control circuit power if the heating element assembly temperature goes above 495°F.
Low Water Thermostat (2TAS)	Monitors presence of water inside steamer.
Hold Thermostat (3TAS)	Controls temperature of cavity for pre-heat/hold mode (opens at 175°F). Disables timer countdown if cavity temperature is too low.
Timer Motor	Counts cook time of product when time is dialed. Energizes buzzer and de-energizes temperature controller when time expires.
Temperature Control	Monitors temperature probe and cycles power to regulating contactor (2 CON) for steam generation.
Temperature Probe	Senses cooking compartment temperature at steam vent and sends a corresponding DC voltage back to the temperature control (J-type thermocouple).
Transformer (1T)	Steps down line voltage to 120 VAC control circuit voltage.
.....	Autofill Components (Optional)
Button Probes	Senses minimal and maximum water levels in steamer.

Fill Solenoid Valves	Used to regulate water flow.
Water Level Alarm (Buzzer)	Creates audible signal when water reaches maximum level.
Transformer	Lowvrs water level alarm to 24V.
Low Water Control Board	Monitors button probes to keep water level maintained.

COMPONENT LOCATION

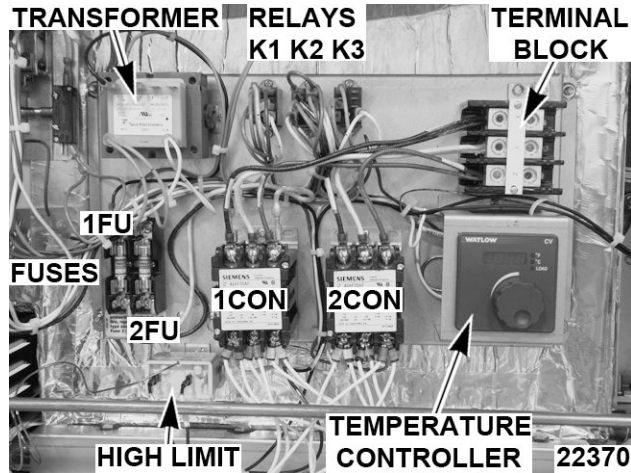

Fig. 60

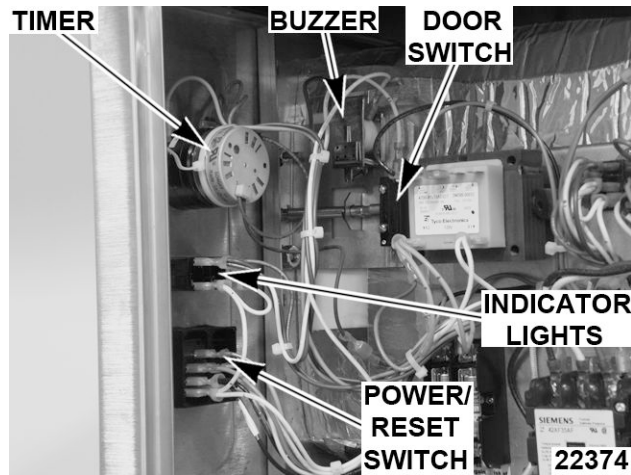
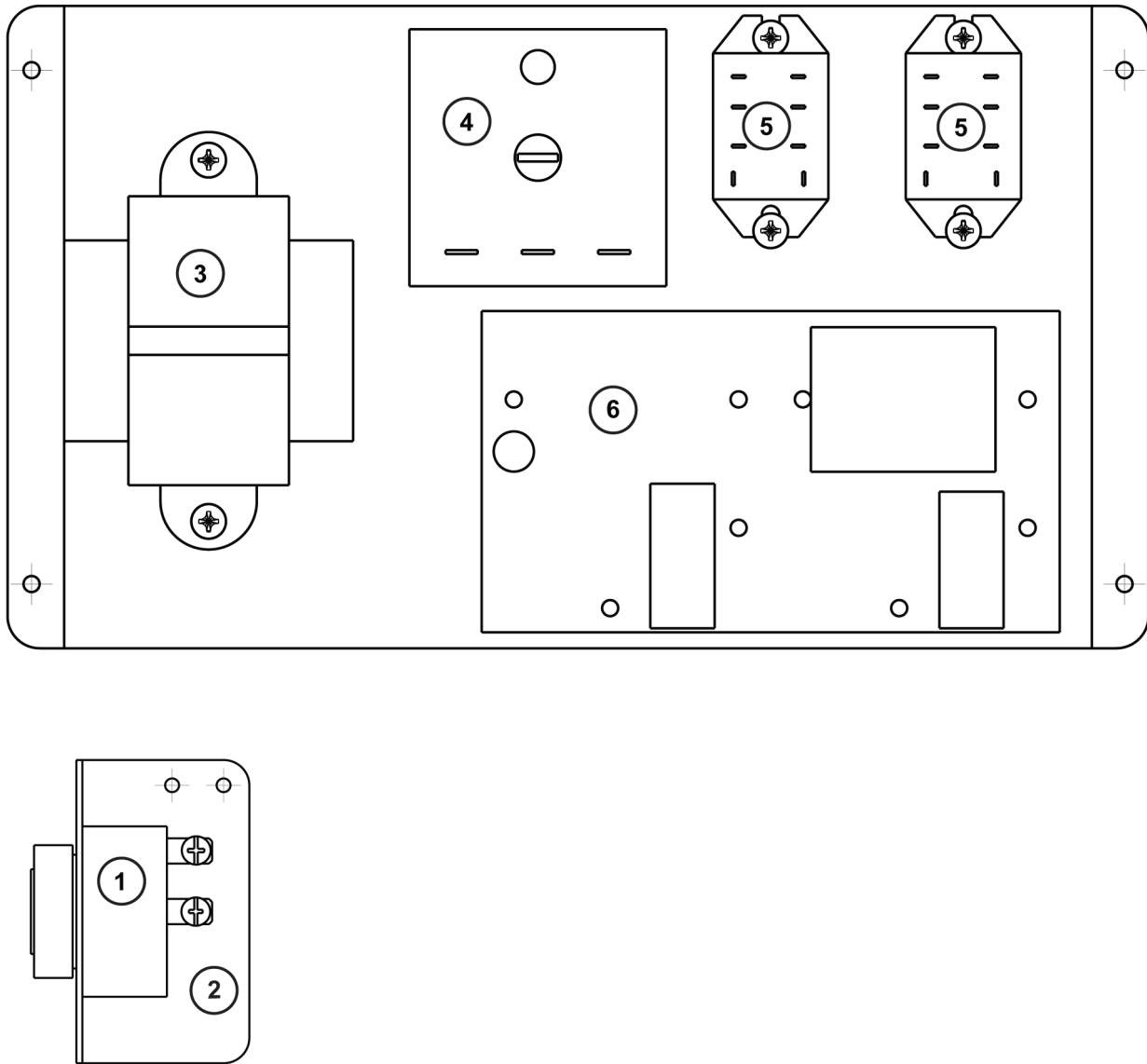

Fig. 61



DERIVED FROM 00-858726 Rev. B

AI4951

Fig. 62

AUTOFILL COMPONENTS	
COMPONENT CALLOUT #	DESCRIPTION
1	Water Level Alarm (Buzzer)
2	Water Level Alarm (Buzzer) Bracket NOTE: Located under the right side panel, toward front of unit.
3	Transformer
4	Time Delay Relay
5	Relay Switches NOTE: Relay switches are connected to overflow light. When replacing relays verify overflow light is operating.

AUTOFILL COMPONENTS	
COMPONENT CALLOUT #	DESCRIPTION
6	Low Water Control Board
NOTE: Autofill is optional. Control board assembly is located under the right side panel and mounted to inside of the back panel.	

SEQUENCE OF OPERATION

SCHEMATIC DIAGRAM AI2851 will be used to explain the electrical sequence of operation.

Timed Cooking Mode

1. Conditions.
 - A. Steamer connected to correct voltage and is properly grounded.
 - B. Power switch (1S) off.
 - 1) Relay K3 energized. K3 N.C. contacts open.
 - C. High limit thermostat closed.
 - D. Hold thermostat closed.
 - E. Low water thermostat closed.
 - F. Temperature control is setup properly and is ready to use.
 - G. Door closed (door switch closed).
 - H. Timer off.
 - I. Cooking compartment filled to the water level mark and below hold temperature of 175°F (+/- 5°F).
 - J. Drain valve is closed (drain lever pushed in).
2. Press momentary start switch (1S).
 - A. Limiting contactor (1CON) coil energized thru high limit thermostat (1TAS).
 - 1) Line voltage is supplied to one side of heating elements.
 - B. Relay K2 coil energized thru low water thermostat (2TAS).
 - 1) K2-1 N.O. contacts close.
 - a. Power switch circuit is latched.
 - 2) K2-2 N.C. contacts open.
 - a. Low water light (1LT) and buzzer are de-energized.
 - C. ON indicator light (2LT, amber) comes on.
 - D. Relay K1 coil energized thru door switch and hold thermostat (3TAS).
 - 1) K1-3 N.O. contacts close and regulating contactor (2CON) coil is energized.
 - a. Line voltage is supplied to other side of heating elements. Elements heat.
 - 2) K1-2 N.C. contacts open.
 - 3) K1-1 N.C. contacts open (prevents timer from being energized during preheat).
3. Steamer reaches 175°F.
 - A. Hold thermostat opens and relay K1 coil is de-energized.
 - 1) K1-3 N.O. contacts close and remove line voltage to heating element assembly.
 - 2) K1-1 and K1-2 N.C. contacts return to close condition.
4. Set cook timer to desired time.

NOTE: Steamer will maintain hold temperature until a cook time is dialed on timer, door is opened, or power switch is turned off.

NOTE: Timer motor will not run when hold thermostat (3TAS) is below 175°F.

 - A. Timer contacts close, timer motor is energized and timing down begins.

NOTE: Additional time can be set or the cook timer can be turned off throughout the cooking cycle. If turned to off, steamer reverts to hold temperature.
 - B. Cook light (3LT, red) comes on.
 - C. Temperature controller energized and evaluates input from thermocouple.
 - 1) If temperature is below set point, temperature controller internal N.O. contacts close and energize regulating contactor (2CON) coil thru K1-2 N.C. contacts.
 - a. Line voltage is supplied to other side of heating elements. Elements heat.

5. Temperature reaches set point and the temperature control's internal N.O. contacts open.
 - A. Regulating contactor (2CON) coil de-energize and power is removed from heating elements.
6. Steamer cycles on the temperature control until cook time expires.
7. Time expires on cook timer.
 - A. Timer contacts 11 & 13 open, timer motor is de-energized and timing stops.
 - B. Timer contacts 11 & 14 close.
 - 1) Buzzer energized thru K2 N.O. contacts and sounds.
8. Turn cook timer off.
 - A. Timer contacts 11 & 14 open, buzzer is de-energize.
 - B. Steamer reverts to hold temperature and continues to cycle until a cook time is dialed on timer, power switch is turned to off, or the door is opened.

NOTE: If water level becomes low during cycling, low water thermostat (2TAS) will open and low water light (1LT, amber) will come on and buzzer will sound. Timer and heating circuit will be de-energized until water level is replenished and thermostat closes.

Constant Cooking Mode

1. Conditions.
 - A. Steamer connected to correct voltage and is properly grounded.
 - B. Power switch (1S) off.
 - 1) Relay K3 energized. K3 N.C. contacts open.
 - C. High limit thermostat closed.
 - D. Hold thermostat closed.
 - E. Low water thermostat closed.

Temperature control is setup properly and is ready to use.
 - F. Door closed (door switch closed).
 - G. Timer off.

- H. Cooking compartment filled to the water level mark and below hold temperature of 175°F (+/- 5°F).
- I. Drain valve is closed (drain lever pushed in).
2. Press momentary start switch (1S).
 - A. Limiting contactor (1CON) coil energized thru high limit thermostat (1TAS).
 - 1) Line voltage is supplied to one side of heating elements.
 - B. Relay K2 coil energized thru low water thermostat (2TAS).
 - 1) K2 N.O. contacts close.
 - a. Power switch circuit is latched.
 - 2) K2 N.C. contacts open.
 - a. Low water light (1LT) and buzzer are de-energized.
 - C. ON indicator light (2LT, amber) comes on.
 - D. Relay K1 coil energized thru door switch and hold thermostat (3TAS).
 - 1) K1 N.O. contacts close and regulating contactor (2CON) coil is energized.
 - a. Line voltage is supplied to other side of heating elements. Elements heat.
 - 2) K1 N.C. contacts open.
3. Steamer reaches 175°F.
 - A. Hold thermostat opens and relay K1 coil is de-energized.
 - B. K1 N.C. contacts close and N.O. contacts open.

NOTE: Steamer will maintain hold temperature until a cook time is dialed on timer, door is opened, or power switch is turned off.

4. Set cook timer to constant.
 - A. Timer contacts 21 & 23 close, cook light (3LT, red) comes on.
 - B. Temperature controller energized and evaluates input from thermocouple.
 - 1) If temperature is below set point, temperature controller internal N.O. contacts close and energize regulating contactor (2CON) coil thru K1 N.C. contacts.

- a. Line voltage is supplied to other side of heating elements. Elements heat.
 5. Temperature reaches set point and the temperature control's internal N.O. contacts open.
 - A. Regulating contactor (2CON) coil de-energize and power is removed from heating elements.
 6. Steamer cycles on the temperature control until cook timer turned off.
 7. Turn cook timer off.
 - A. Timer contacts 21 & 23 open, cook light (3LT, red) goes out and temperature controller is de-energized.
 - B. Steamer reverts to hold temperature and continues to cycle until a cook time is dialed on timer, power switch is turned to off, or the door is opened.
- NOTE:** If water level becomes low during cycling, low water thermostat (2TAS) will open and low water light (1LT, amber) will come on and buzzer will sound.
- Autofill**
Timed Cooking Mode
- NOTE: Difference in use of the WLCB in the EA (3 probe) vs. EO (2 Probe).** EO Water level control only uses two probes for operation. The lower probe controls water level, with a time delay after the probe level is reached. The top probe is used as overflow alarm.
1. Conditions.
 - A. Steamer connected to the correct voltage and is properly grounded.
 - B. Power switch (1S) off. Relay K3 energized. K3 N.C. contacts open.
 - C. High limit thermostat (1TAS) closed.
 - D. Hold thermostat (3TAS) closed.
 - E. Low Water thermostat (2TAS) closed.
 - F. Temperature control is setup properly and is ready to use.
 - G. Door closed (door switch (1SW) closed).
 - H. Timer off.
 - I. Drain valve is closed (drain lever pushed in).
 - J. Cooking compartment empty or may manually fill to the level mark and below hold temperature of 175°F (± 5°F).
 2. Press momentary start switch (1S).
 - A. Limiting contactor (1CON) coil energized through high limit thermostat (1TAS).
 - 1) Line voltage is supplied to one side of heating elements.
 - B. Water Level Control board energized.
 - 1) Fill Solenoid (1SOL) energized through LLCO-NO Contact and relay K4.
 - a. Overflow Light (4LT) de-energized.
 - b. Overflow Buzzer de-energized.
 - 2) K4 N.O. contact close.
 - 3) Relay K4 will remained energized until the water level reaches the lower limit probe.
 - 4) Once water level is reached, Relay K4 opens, and the Time Delay Relay is activated, energizing Relay K5
 - 5) Relay K5 is energized for 10 seconds until the timer expires allowing the water to fill above the lower water probe
 - a. K5 relay will be energized for 10 seconds and K5 N.O. contact will close, keeping solenoid energized.
 - b. Water Solenoid (1SOL) will De-energize after Relay K5 de-energizes.
 - C. Should Solenoid fail to de-energize thus causing an overflow.
 - 1) If water reaches the HL probe, the WLC-HL N.O contacts will open and the WLC-HL N.C. contact close.
 - 2) The Overflow light (4LT) will illuminate.
 - 3) The Overflow buzzer will simultaneously activate.
 - D. Returns to normal operation.
 - E. ON indicator light (2LT, Amber) comes on.
 - F. Relay K1 coil energized through door switch and hold thermostat (3TAS).
 - 1) K1-3 N.O. contacts close and regulating contactor (2CON) coil is energized.
 - a. Line voltage is supplied to other side of heating elements.

- b. Elements heat.
- 2) K1-N.C. contacts open.
- 3) K1-1 N.C. contacts open (prevents timer from energizing during Pre-Heat).

G. Steamer reaches 175 °F.

- 1) Hold thermostat opens and relay K1 coil is de-energized.
 - a. K1-3 N.O. contacts close and remove line voltage to heating element assembly.
 - b. K1-1 and K1-2 N.C. contacts return to close condition.

NOTE: Steamer will maintain Hold temperature until a cook time is dialed on timer, door is opened, or power switch is turned off.

- 2) Set cook timer to desired time.

NOTE: Timer motor will not run when the hold thermostat (3TAS) is below 175 °F.

- a. Timer contacts close, timer motor is energized, and timing down begins.

NOTE: Additional time can be set, or the cook timer can be turned off throughout the cooking cycle. If turned to off, steamer reverts to hold temperature.

- b. Cook light (3LT, red) comes on.
- c. Temperature controller energized and evaluates input from the thermocouple.
 - a) If temperature is below set point, temperature controller internal N.O. contacts close and energize regulating contactor (2CON) coil thru K1-2 N.C. contacts.

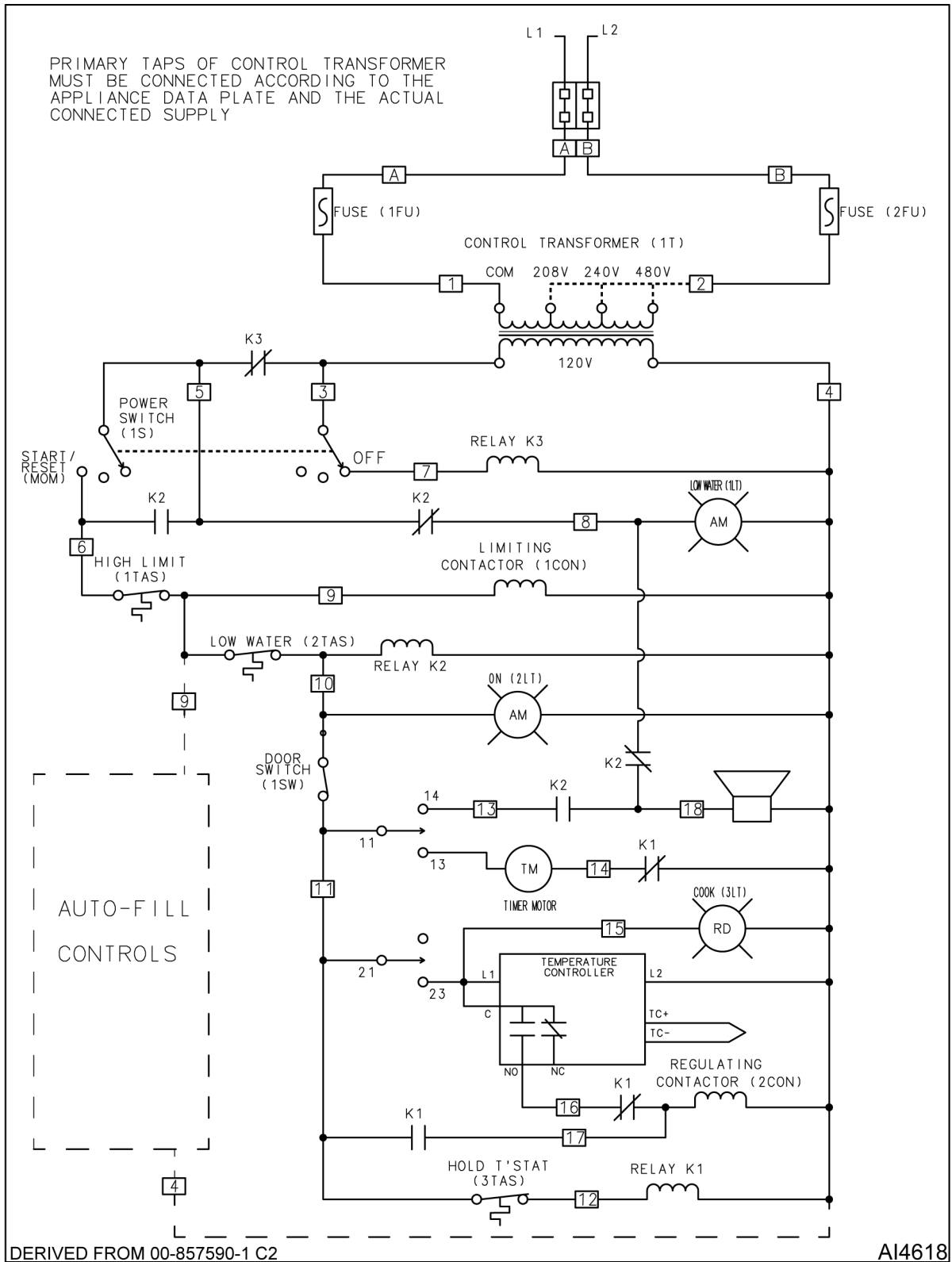

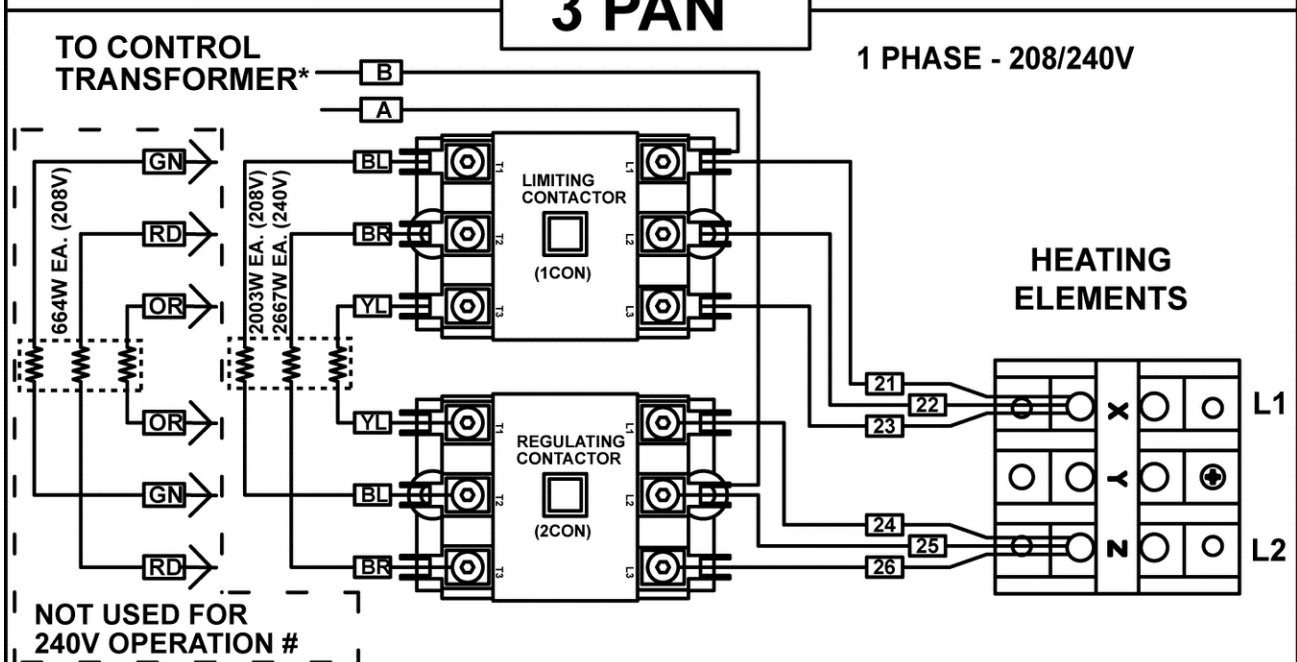
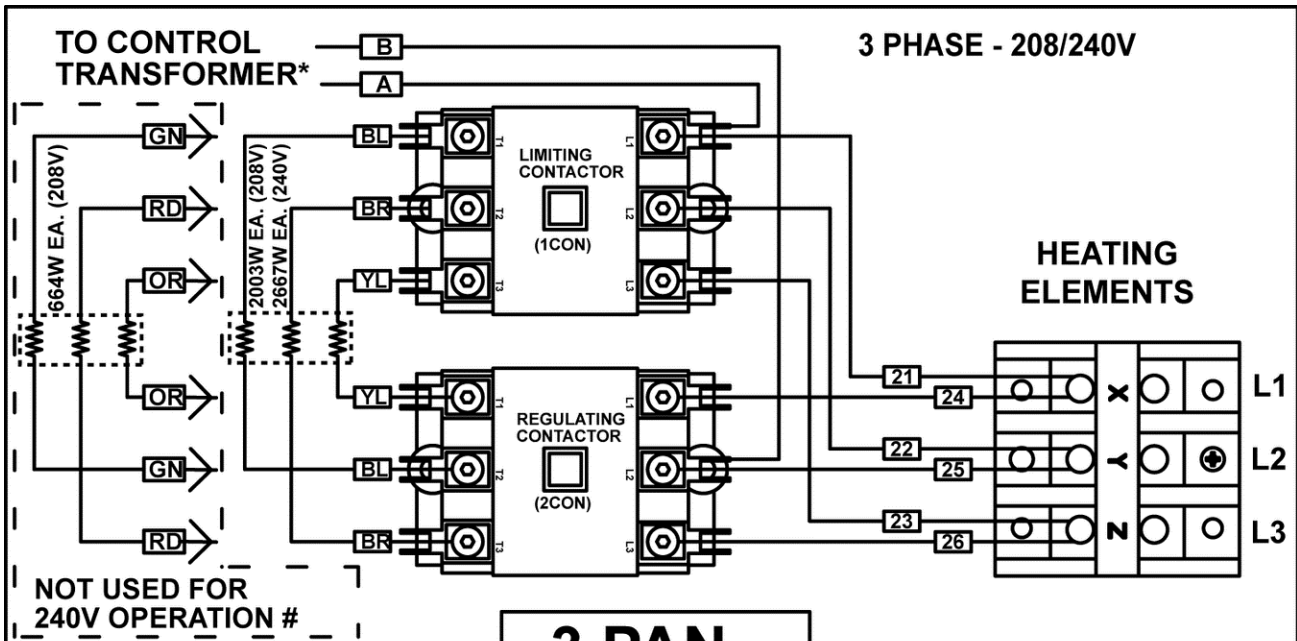

FOR OPERATION FROM A 208V SUPPLY, ALL 6 ELEMENTS ARE TO BE CONNECTED AS SHOWN. FOR 240V SUPPLY, DISCONNECT AND INSULATE ELEMENT LEADS WITH ORANGE, GREEN, AND RED MARKERS.

* PRIMARY TAPS OF CONTROL TRANSFORMER MUST BE CONNECTED ACCORDING TO THE APPLIANCE DATA PLATE VOLTAGE MARKING AND ACTUAL CONNECTED SUPPLY

DERIVED FROM 00-857591-3 Rev B

AI2853

C24EO3 - 208V/240V

C24EO5 - 208V/240V

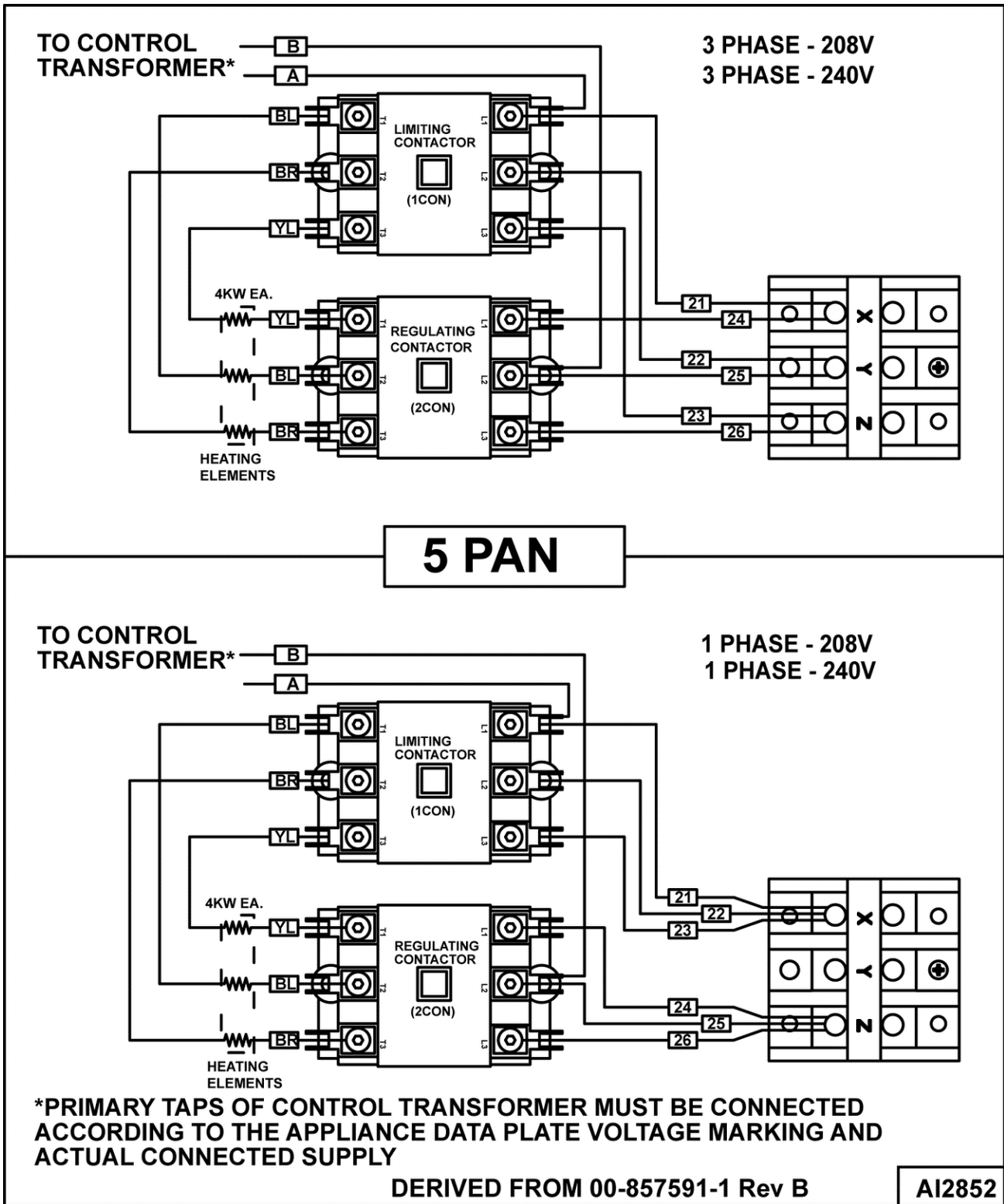

C24EO5 - 208V/240V

C24EO5 - 480V

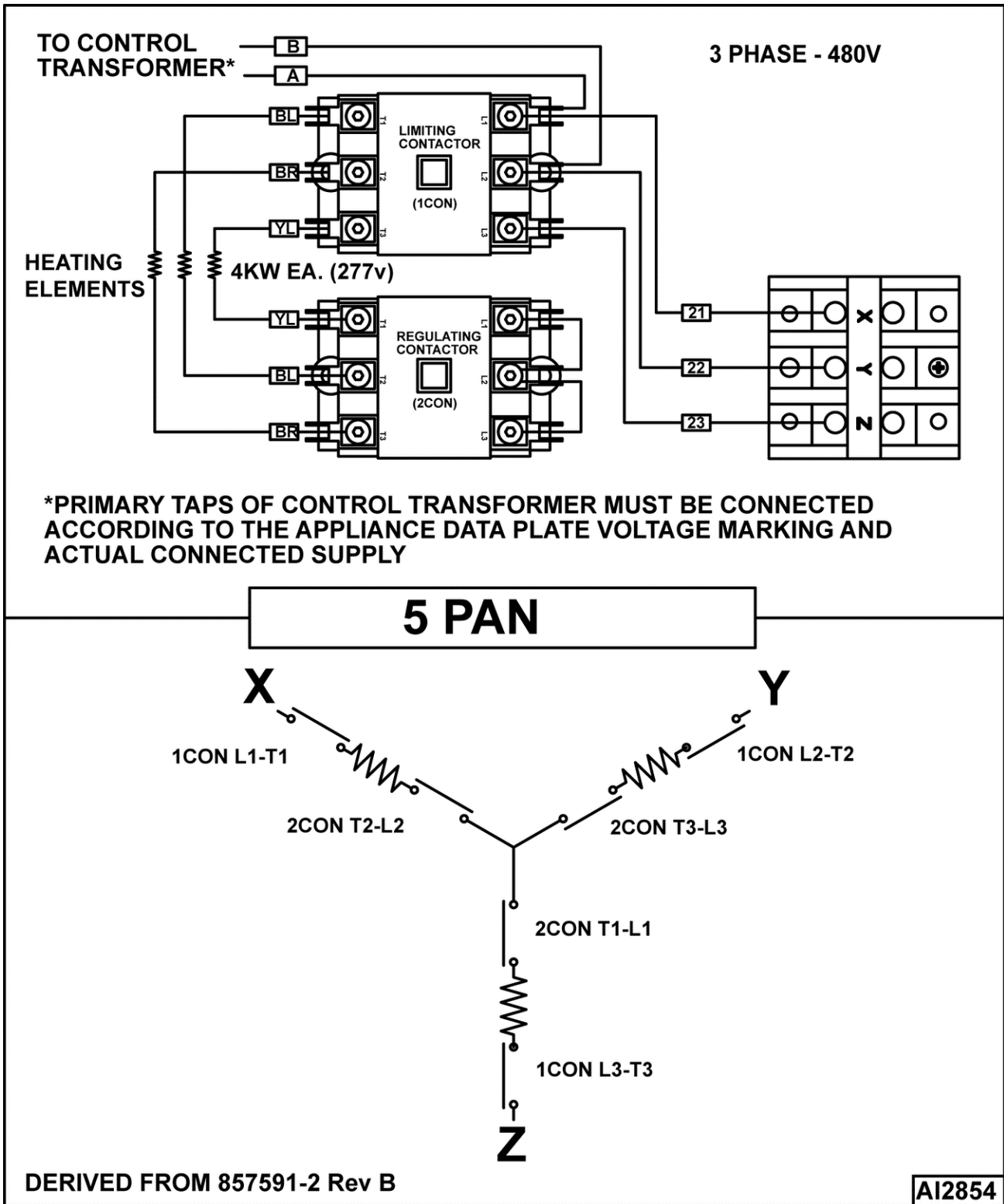

C24EO5 - 480V

TROUBLESHOOTING

TROUBLESHOOTING

SYMPTOM	POSSIBLE CAUSES
Compartment leaks water around door.	<ol style="list-style-type: none"> 1. Steamer not level. 2. Steamer overfilled.
Steam leaks around door.	<ol style="list-style-type: none"> 1. Worn gasket. 2. Damaged gasket. 3. Steam vent pipe blocked. 4. Door not adjusted.
Steamer will not heat (cook light off, low water light off).	<ol style="list-style-type: none"> 1. Line voltage incorrect or transformer malfunction. 2. Control circuit fuse(s) open. 3. High limit thermostat open. 4. Door open or door switch malfunction. 5. Power switch off or inoperative. 6. Relay K3 malfunction. 7. Timer malfunction or timer off (timed mode only).
Steamer will not heat (cook light on, low water light off).	<ol style="list-style-type: none"> 1. Line voltage incorrect. 2. Heating element malfunction. 3. Regulating contactor malfunction. 4. Relay K1 malfunction. 5. Temperature probe malfunction. 6. Temperature controller malfunction.
Timer motor does not run.	<ol style="list-style-type: none"> 1. Door open or door switch malfunction. 2. High limit thermostat open. 3. Low water thermostat open. 4. Timer inoperative.
Door not closing properly.	<ol style="list-style-type: none"> 1. Door latch assembly. 2. Striker adjustment.
Door won't open.	<ol style="list-style-type: none"> 1. Latch inoperative.
Buzzer not operating.	<ol style="list-style-type: none"> 1. Timer malfunction. 2. Buzzer malfunction.
Water spraying out of steam vent pipe during a cook cycle.	<ol style="list-style-type: none"> 1. Temperature control set point too high. 2. Temperature probe malfunction. 3. Temperature control malfunction.

SYMPTOM	POSSIBLE CAUSES
High water usage.	<ol style="list-style-type: none"> 1. Temperature control set point too high. 2. Temperature probe malfunction. 3. Temperature control malfunction. 4. Steamer operating in constant mode.
Excessive or inconsistent cook times.	<ol style="list-style-type: none"> 1. Door left open between loads. 2. Temperature control set point too low. 3. Heating element malfunction.

AUTOFILL OPTION	
SYMPTOM	POSSIBLE CAUSES
Steamer will not fill.	<ol style="list-style-type: none"> 1. Verify water supply. <ul style="list-style-type: none"> • Water pressure, 20-60 psi. 2. Verify supply valve is on. 3. Verify screen on valve is free of obstructions. 4. Verify power supply to water level control board. 5. Verify operation of the water level control board. 6. Verify Probes are free of scale. 7. Verify Probes are connected properly. 8. Verify hoses are not kinked. 9. Verify water supply lines are not kinked.
Steamer overfills.	<ol style="list-style-type: none"> 1. Verify time delay relay is set at 10 seconds. 2. Verify probes are wired correctly. 3. Verify probes are free of scale. 4. Verify power supply to water level control board. 5. Verify operation of the water level control board. 6. Verify water supply. <ul style="list-style-type: none"> • Water pressure, 20-60 psi. 7. Unit is grounded properly.
Buzzer does not work.	<ol style="list-style-type: none"> 1. Check 24VAC to buzzer. 2. Check transformer wiring. 3. Check time delay relay. 4. Verify operation of water level control board.

AUTOFILL OPTION	
SYMPTOM	POSSIBLE CAUSES
Overfill light not illuminating.	<ol style="list-style-type: none"> 1. Check 120VAC to light. 2. Verify power supply to water level control board. 3. Verify operation of the water level control board. 4. Verify water supply. <ul style="list-style-type: none"> • Water pressure, 20-60 psi. 5. Verify supply valve is on. 6. Verify screen on valve is free of obstructions. 7. Verify time delay relay is at 10 seconds. 8. Verify time delay relay is working properly.
Time delay relay not working.	<ol style="list-style-type: none"> 1. Verify 120VAC to TDR. 2. Verify K4 wiring is correct. 3. Verify power supply to water level control board. 4. Verify operation of the water level control board.
Water leaks inside the control area.	<ol style="list-style-type: none"> 1. Verify water supply. <ul style="list-style-type: none"> • Water pressure, 20-60 psi. 2. Verify all hose connections. <ul style="list-style-type: none"> • Check hoses for damage. • Replace any leaking hose clamps. 3. Check probes. <ul style="list-style-type: none"> • Verify probes are securely installed. • Check seals for cracks or damage. 4. Verify drain is not leaking. 5. Verify water valve is not cracked. 6. Verify cold water is supplied to unit. <div style="margin-top: 10px; border: 1px solid black; padding: 2px;">NOTICE</div> Unit will not run properly if supply water is hot. Must be a cold water supply. 7. Check cavity welds for cracks. 8. Verify unit was not power washed.